

# SEARS

## OWNER'S MANUAL

**MODEL NO.  
987.799601**

**⚠ Caution:**  
Read and Follow  
All Safety Rules  
and Instructions  
Before Operating  
This Equipment.

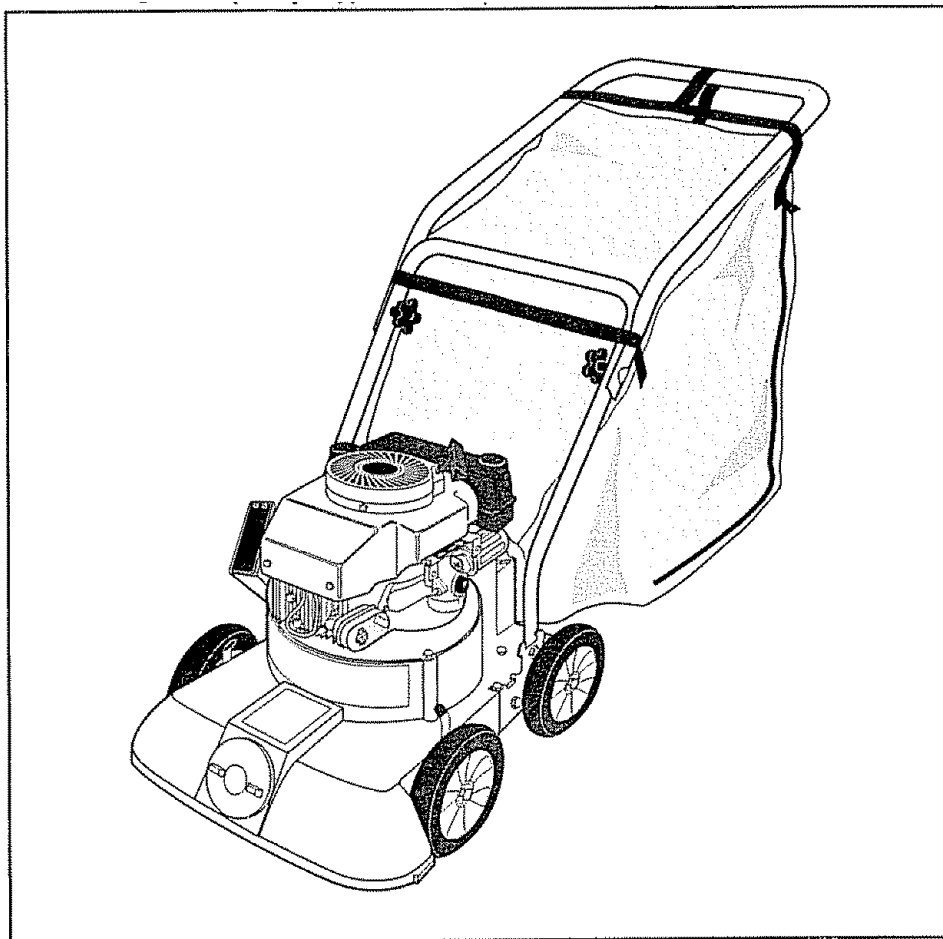

# CRAFTSMAN<sup>®</sup>

**5 Horsepower  
CHIPPER/VAC  
with Wheel Adjusters**

- **Assembly**
- **Operation**
- **Customer Responsibilities**
- **Service and Adjustment**
- **Repair Parts**

**Sears, Roebuck and Co., Hoffman Estates, IL 60179 U.S.A.**

# SAFETY RULES



**CAUTION: ALWAYS DISCONNECT SPARK PLUG WIRE AND PLACE WIRE WHERE IT CANNOT CONTACT SPARK PLUG TO PREVENT ACCIDENTAL STARTING WHEN SETTING UP, TRANSPORTING, ADJUSTING, OR MAKING REPAIRS.**



## IMPORTANT

**YOUR UNIT IS EQUIPPED WITH A SAFETY INTERLOCK SYSTEM TO MINIMIZE INJURY. DO NOT ATTEMPT TO DEFEAT THIS SYSTEM UNDER ANY CIRCUMSTANCES.**

### TRAINING:

- Read this Owner's Manual carefully before operating this equipment. Be thoroughly familiar with the controls and the proper use of this equipment.
- Never allow children or untrained adults to operate this equipment.
- Keep the area of operation clear of all persons, particularly small children, and pets. Keep bystanders at least 25 feet away from the area of operation.
- Familiarize yourself with all of the safety and operating decals on this equipment and on any of its attachments or accessories.
- Do not run engine in an enclosed area. Engine exhaust contains carbon monoxide gas, a deadly poison that is odorless, colorless, and tasteless. Do not operate this equipment near buildings, windows, or air conditioners.
- Do not allow hands or any other part of the body or clothing inside the vacuum inlet, chipper chute, discharge opening, blower deflector, or near any moving part. Cutting blades begin to rotate when engine starts and slow down gradually after engine is shut off.
- Before inspecting or servicing any part of the equipment, stop the engine and make sure that all moving parts have come to a complete stop. Disconnect the spark plug wire and secure it away from the spark plug. Be aware that rotating blades slow down gradually after engine is shut off.
- Do not operate this equipment if you are under the influence of alcohol, medication, or when tired or ill.
- Do not wear loose-fitting clothing or jewelry that can get drawn into the vacuum inlet or chipper chute, or that can get caught by moving parts.
- Do not operate this equipment unless the collection bag or blower deflector is installed.
- Do not process material through chipper chute when equipment is on uneven ground.
- Before starting engine, check that all screws, nuts, bolts, and other fasteners are properly secured. Replace any damaged or unreadable warning and operating decals.
- Wear work gloves, sturdy footwear, and hearing protection when operating this equipment.
- Use extra care when handling gasoline and other fuels. Gasoline and its vapors are highly flammable and explosive. To help prevent a fire or explosion:
  - a. Use an approved fuel container.
  - b. Never add fuel to a running or a hot engine.
  - c. Keep matches, smoking materials, open flames, and sparks away from the fuel tank and fuel container.
  - d. Fill the fuel tank outdoors and with extreme care. Never fill fuel tank indoors.
  - e. Replace the caps on the fuel tank and fuel container and clean up spilled fuel before starting engine. Gas cap shall never be removed or fuel added while engine is running.
- Leave 1/2 inch air space at top of fuel tank to allow for expansion of fuel.
- Do not store the machine or fuel container where there is an open flame or spark, or where ignition sources such as hot water and space heaters, furnaces, clothes dryers, stoves, or electric motors are present.

### PREPARATION:

- Always wear approved safety goggles (provided) when operating this equipment. The operation of any powered machine can result in foreign objects being thrown by high-speed rotating parts.



**LOOK FOR THIS SYMBOL TO POINT OUT IMPORTANT SAFETY PRECAUTIONS. IT MEANS – ATTENTION!!! BECOME ALERT!!! YOUR SAFETY IS INVOLVED.**

## OPERATION:

- Before starting this equipment, make certain that the chipper chute, vacuum inlet, discharge opening, and blower deflector are empty. Disconnect spark plug wire before making these checks.
- Never carry passengers on this equipment. They could fall off and be seriously injured, or they could interfere with safe operation.
- Do not allow hands or any other part of the body or clothing inside the vacuum inlet, chipper chute, discharge opening, blower deflector, or near any moving part.
- Before vacuuming, inspect the area where the equipment is to be used and remove all metal, bottles, cans, or other foreign objects.
- Do not vacuum any burning or smoldering materials such as cigars, cigarettes, ashes, or cinders.
- When vacuuming or chipping, be extremely careful that pieces of metal, rocks, bottles, cans, or other foreign objects are not included.
- Do not use vacuum or blower on areas that have been recently treated with fertilizers, pesticides, or herbicides. Follow chemical manufacturer's safety instructions regarding contact with treated areas.
- Do not vacuum flammable liquids such as gasoline, kerosene, diesel fuel, paint thinner, etc.
- If equipment strikes any foreign object or starts making an unusual noise or vibration, immediately shut off engine and allow all moving parts to come to a complete stop. Disconnect the spark plug wire and secure it away from the spark plug. Then take the following steps:
  - a. Inspect for damage.
  - b. Replace or repair any damaged parts.
  - c. Check for and tighten any loose parts.
- If equipment jams or becomes clogged, immediately shut off the engine and allow all moving parts to come to a complete stop. Disconnect the spark plug wire and secure it away from the spark plug. Use only a wooden stick to clear away debris.
- Before adding or changing any attachments or before switching between vacuum and blower operation stop the engine and allow all moving parts to come to a complete stop. Disconnect the spark plug wire and secure it away from the spark plug.
- Keep all guards, covers, and shields in place and in good working condition.
- Always stand clear of discharge area when operating equipment with blower deflector installed. Material exits at a high speed from the blower deflector.
- Do not operate the chipper with the blower deflector installed.
- Do not operate the chipper if the chipper chute flap is damaged or missing.
- Keep your face and body safely away from the chipper chute. When chipping, stand on either side of chute and keep arms perpendicular (at a 90° angle) to chute inlet.
- Do not overreach when feeding material into the chipper chute. Keep proper balance and footing at all times.
- Check collection bag frequently for deterioration or wear and replace worn bags. Use only original equipment replacement bags. Bags manufactured by others could present a safety hazard.
- Before removing and installing collection bag, stop the engine and allow all moving parts to come to a complete stop. Disconnect the spark plug wire and secure it away from the spark plug.
- Empty the collection bag after each use. Decomposing debris could generate enough heat to catch fire.
- Exercise extreme caution on slopes and avoid excessively steep slopes.
- Never operate this equipment on a slippery surface.
- Look behind and use care when operating in reverse.
- Do not allow any part of the engine, especially around the cooling fins and muffler to become clogged with leaves, oil, grease, or any other combustible material.
- Watch for traffic when operating near, or when crossing roadways.
- Never leave the equipment unattended when the engine is running. Stop the engine, disconnect spark plug wire, and secure it away from the spark plug before leaving the equipment.
- Use only attachments and accessories that are approved for use with this equipment.
- Operate equipment only in daylight or in good artificial light.
- Do not tamper with the engine governor settings. The governor controls the maximum safe operating speed and protects the engine and all moving parts from damage caused by excessive speed. Request help at the nearest Sears service location if a problem exists.
- This equipment is provided with a safety interlock system which prevents the engine from starting unless the collection bag or blower deflector is installed. The system is also designed to shut off the engine if the operator attempts to remove the collection bag or blower deflector while the engine is running. Never attempt to disconnect or otherwise defeat the purpose of this system. If the interlock fails to operate properly, shut off the engine and do not operate this equipment until the system is repaired and is functioning properly.

## **MAINTENANCE AND STORAGE:**

- When equipment is stopped for servicing, inspection, storage, or to change an attachment or accessory, make sure the spark plug wire is disconnected from the spark plug. Allow the engine to cool before making any inspections, adjustments, etc.
- Maintain equipment and all attachments and accessories in safe working condition.
- Never perform any maintenance while engine is running or when spark plug wire is connected to spark plug, except where specifically instructed to do so.
- Never store this equipment with fuel in the fuel tank inside a building where fumes may reach an open flame or spark, or where ignition sources are present such as hot water and space heaters, furnaces, clothes dryers, stoves, electric motors, etc.
- Allow engine to cool before storing in any enclosure.
- Store gasoline in a cool, well-ventilated area, safely away from any spark- or flame-producing equipment. Store gasoline in an approved container, safely out of the reach of children.
- Use only original equipment replacement parts. Parts manufactured by others could present a safety hazard even though they may fit on this equipment.
- Store this equipment where children will not have access. Always disconnect the spark plug wire from the spark plug to prevent accidental starting.
- Check collection bag frequently for deterioration or wear and replace worn bags. Use only original equipment replacement bags. Bags manufactured by others could present a safety hazard.
- Refer to "Off Season Storage" in this Manual for important storage instructions if equipment is to be stored for an extended period.

## **SAFETY DECALS:**

- Make certain that all safety decals on this equipment are kept clean and in good condition. The decals are shown on Page 35 of this Manual.

CONGRATULATIONS on your purchase of a Sears Craftsman Chipper/Vac. It has been designed, engineered and manufactured to give you the best possible dependability and performance.

Should you experience any problems you cannot easily remedy, please contact your nearest Sears Service Center or Retail Store. We have competent, well-trained technicians and the proper tools to service or repair this machine.

Please read and keep this Manual. The instructions will help you assemble, operate, and maintain your machine properly. Always observe the SAFETY RULES.

<p>MODEL NUMBER 987.799601</p> <p>SERIAL NUMBER: _____</p> <p>DATE OF PURCHASE: _____</p> <p>THE MODEL AND SERIAL NUMBER DECAL IS LOCATED ON THE LEFT SIDE OF THE ENGINE MOUNTING PLATFORM.</p> <p>YOU SHOULD RECORD BOTH THE SERIAL NUMBER AND THE DATE OF PURCHASE. KEEP THEM IN A SAFE PLACE FOR FUTURE REFERENCE.</p>
---

## PRODUCT SPECIFICATIONS

<b>Chipper/Vac</b>	
Weight	65 lbs.
Length with Handlebars Extended	48 in.
Length with Handlebars Folded	28 in.
Width	22 in.
<b>Engine</b>	
Engine	5 HP Tecumseh Model TVS 115
Engine Type	Vertical Crankshaft Air-Cooled Four Cycle
Engine Displacement	11.5 cu in.
Gasoline Capacity	1-1/4 qts.
Oil (21 ounce capacity)	Above 32° F: SAE 30 Below 32° F: SAE 5W30
Spark Plug (gap 0.030-in.)	Champion J19LM Autolite 458, or equivalent. In Canada, replace with resistor spark plug.
Valve Clearance	Intake: .006 in. Exhaust: .006 in.

**WARNING:** This chipper/vac is equipped with an internal combustion engine and should not be used on or near any unimproved forest-covered, brush-covered or grass-covered land unless the engine's exhaust system is equipped with a spark arrester meeting applicable local or state laws (if any). If a spark arrester is used, it should be maintained in effective working order by the operator.

In the state of California the above is required by law (Section 4442 of the California Public Resources Code). Other states may have similar laws. Federal laws apply on federal lands. A spark arrester for the muffler is available through your nearest Sears authorized service center. See the REPAIR PARTS section of this manual.

### MAINTENANCE AGREEMENT

A Sears maintenance agreement is available on this chipper/vac. Contact your nearest Sears store for details.

### CUSTOMER RESPONSIBILITIES

- Read and observe the safety rules.
- Follow a regular schedule in maintaining, caring for and using your chipper/vac.
- Follow the instructions under "Customer Responsibilities" and "Storage" sections of this manual.

## LIMITED ONE YEAR WARRANTY

For One Year from date of purchase, when this Chipper/Vac is maintained, lubricated, and tuned up according to the operating and maintenance instructions in the Owner's Manual, Sears will repair free of charge any defect in material or workmanship.

This warranty excludes the collection bag, spark plug, air cleaner, and chipper blade which are expendable parts and become worn during normal use.

If this Chipper/Vac is used for commercial or rental purposes, this warranty applies for only 30 days from the date of purchase.

WARRANTY SERVICE IS AVAILABLE BY CONTACTING THE NEAREST SEARS SERVICE CENTER/DEPARTMENT IN THE UNITED STATES. This warranty applies only while this product is in use in the United States.

This warranty gives you specific legal rights, and you may also have other rights which vary from state to state.

SEARS, ROEBUCK AND CO., D/817WA – HOFFMAN ESTATES, IL 60179



---

## ATTACHMENTS

---

This attachment was available when the chipper/vac was purchased. It is available at most Sears retail outlets and service centers. Most Sears stores can also order repair parts for you, when you provide the model number of your chipper/vac.

### VACUUM HOSE

The optional vacuum hose attachment allows you to extend the reach of the machine by 10 feet to easily reach in, around, under and behind bushes, shrubs, trees, fences, lawn furniture, etc. If you purchased a vacuum hose with the chipper/vac, you will find it packaged in a separate carton.

Instructions for installation and use of the vacuum hose are presented in this Manual. See "Vacuum Hose Operation" on Page 14.

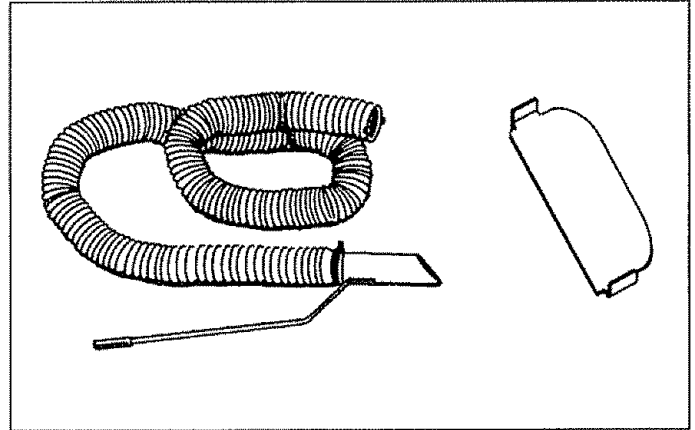

*Optional vacuum hose and baffle plate.  
(Stock No. 71-85689)*

### ENGINE ACCESSORIES

Engine accessories such as gas cans, engine oil, and replacement spark plugs are also available at your local Sears service center and most Sears retail outlets.

# ASSEMBLY

Read these instructions in their entirety before you attempt to assemble your new chipper/vac. Your new chipper/vac has been completely assembled at the factory, except for the items shown in Figure 1. To ensure proper operation of your chipper/vac, all nuts and bolts must be securely tightened when changing the configuration of the machine. Use the correct tools as necessary to ensure proper tightness.

## UNPACKING INSTRUCTIONS (see Figure 1)

1. The following items are contained in the shipping carton and shown in Figure 1:

- (A) Chipper/Vac
- (B) Safety Goggles
- (C) Blower Deflector
- (D) Collection Bag

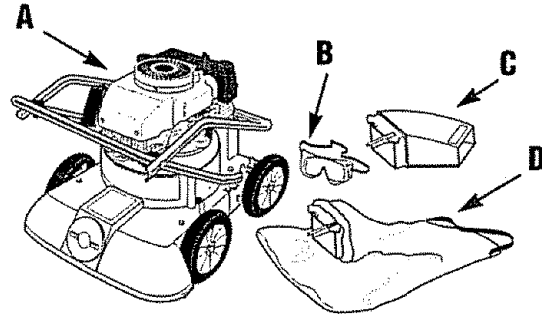

Figure 1: Contents of shipping carton.

2. Check for missing or damaged parts. If any parts are missing or damaged, contact your local Sears service center or Sears retail outlet for assistance.

**IMPORTANT:** MOTOR OIL AND GASOLINE MUST BE ADDED TO THE ENGINE BEFORE THE ENGINE IS STARTED. THE PROCEDURES FOR ADDING MOTOR OIL AND GASOLINE ARE ON PAGES 18 AND 19.

NOTE: All references to the front, rear, left and right of the machine are determined as follows:

The inlet cap for the optional vacuum hose is located on the front of the machine. The discharge opening is at the rear. The left and right sides are determined by standing at the rear of the machine when the handlebars are in the "vacuum" position.

## UNFOLD THE HANDLEBARS (see Figure 2)

1. Squeeze the handlebar end (with decal "Push in Here") toward the center of the machine to release end from the notch in the mounting bracket (C) and swing the handlebars up over the machine toward the rear.
2. Position the handlebar ends in the "vacuum" notches of the brackets (D in Figure 2 inset).
3. Unfold the handlebars until the channels on the upper left and right handlebars are aligned with the lower handlebars (A). If necessary, loosen knobs (B) before unfolding handlebars.
4. Tighten the knobs (B).

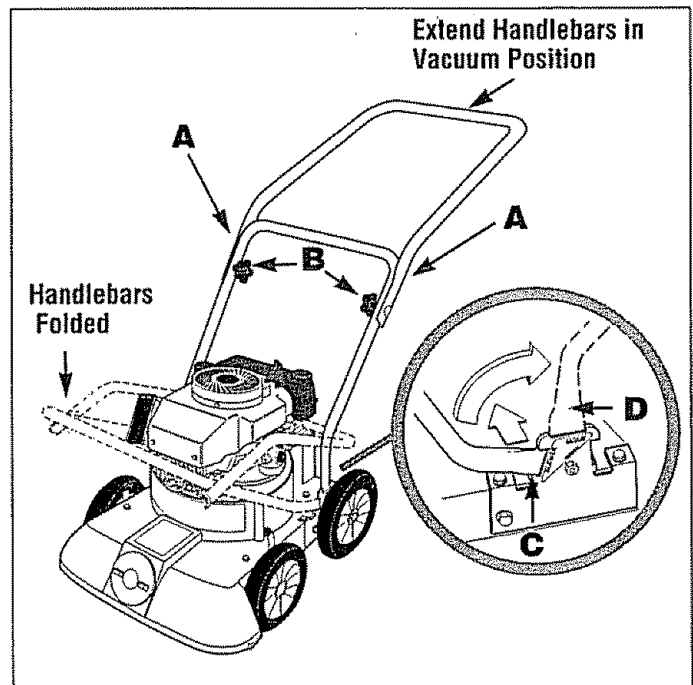

Figure 2: Handlebar position for vacuuming.

## CHECK ALL NUTS AND BOLTS FOR TIGHTNESS

Check all nuts and bolts for tightness following assembly and according to the schedule given in the section which describes "Customer Responsibilities" on Page 27.

NOTE: Do not overtighten the bolts which attach the engine mounting plate to the housing. DAMAGE TO THE HOUSING COULD RESULT.

# ASSEMBLY

## ASSEMBLY CONFIGURATIONS

Your machine has been partially assembled at the factory. The remaining assembly steps should be done on a clean, level surface. Choose the mode of operation from the pictures below and then go to the page for assembly of the chipper/vac in the desired configuration.



## CAUTION

To prevent personal injury or property damage, do not connect the spark plug or start the engine until all assembly steps are complete and you have read and understood the safety and operating instructions in this Manual.

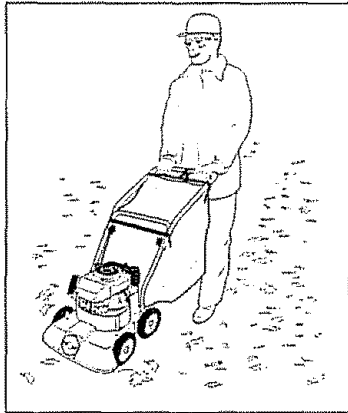

*Walk-behind vacuuming - see Page 10*

### WALK-BEHIND VACUUMING OPERATION CHECKLIST

- ✓ Collection bag installed and zipped.
- ✓ Baffle plate off (provided with optional vacuum hose kit only)
- ✓ Vacuum inlet cap installed.
- ✓ Handlebars positioned toward the rear of the machine.

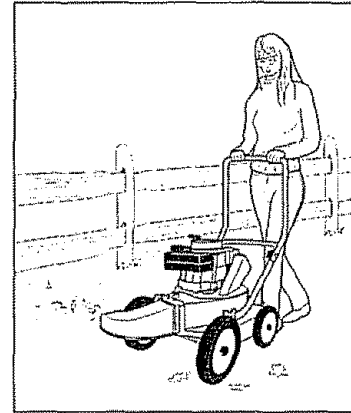

*Blower operation - see Page 12*

### BLOWER OPERATION CHECKLIST

- ✓ Handlebars positioned toward the front of the machine.
- ✓ Collection bag removed.
- ✓ Blower deflector installed.
- ✓ Vacuum inlet cap installed.
- ✓ Baffle plate off (provided with optional vacuum hose kit only)

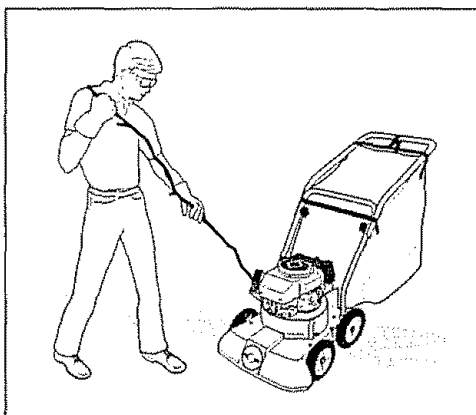

*Using the chipper - see Page 10*

### CHIPPER OPERATION CHECKLIST

- ✓ Handlebars positioned toward the rear of the machine.
- ✓ Collection bag installed and zipped.
- ✓ Blower deflector and baffle plate (optional) off.
- ✓ Vacuum inlet cap installed.

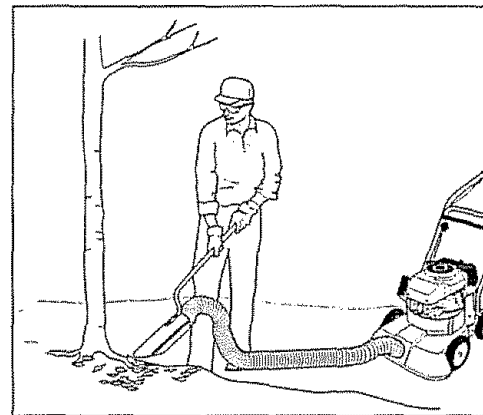

*Using the vacuum hose (optional) - see Page 14*

### VACUUM HOSE OPERATION CHECKLIST

- ✓ Handlebars positioned toward the rear of the machine.
- ✓ Collection bag installed and zipped.
- ✓ Baffle plate on.
- ✓ Vacuum hose installed.

# ASSEMBLY

## ASSEMBLY FOR WALK-BEHIND VACUUMING OR USING THE CHIPPER

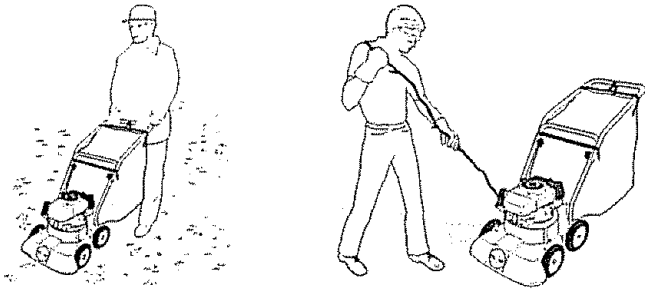

### STEP 1: REMOVE OR INSTALL SHREDDER SCREEN

A shredder screen (A, Figure 3) is factory-installed inside the processing chamber. Vacuumed or chipped material passes through the slots in the screen before it is discharged. The screen produces up to an 8:1 reduction of material.

The screen is designed for use only with dry materials. Before processing damp materials, remove the screen to reduce clogging and to improve air flow inside the processing chamber. Before chipping a large number of branches, remove the shredder screen for faster discharge of the chips.

#### To Remove Shredder Screen:

1. **Stop the engine, disconnect the spark plug wire from the spark plug, and make sure that all moving parts have come to a complete stop.**
2. To remove rear rod (B, Figure 3), remove the collection bag or the blower deflector (if installed). Then, remove the hair pin clip (D) and pull the rod out through the bottom of the deck.
3. Use sturdy supports to prop up the right side of the machine a few inches. Then, remove the hair pin clip (D) and pull the front rod (C) out through the bottom of the deck.

4. Pull the screen (A) out of the discharge opening. Re-install the rods and hair pin clips on the screen for safe-keeping.

**IMPORTANT:** THE HAIR PIN CLIPS SUPPLIED WITH THE SCREEN ARE THE ONLY STYLE FASTENERS THAT SHOULD BE USED. DO NOT USE SUBSTITUTES OR FAILURE OF EQUIPMENT OR PERSONAL INJURY COULD RESULT.

5. Remove supports from beneath machine.

#### To Install Shredder Screen:

1. **Stop the engine, disconnect the spark plug wire from the spark plug, and make sure that all moving parts have come to a complete stop.**
2. Remove the collection bag. Remove the rods and hair pin clips which were stored on the shredder screen. Insert the screen (A) into the processing chamber with the flat, angled end facing to the rear and the curve in the screen facing to the right. See Figure 3. Align mounting holes in screen with the holes in deck.
3. Using sturdy supports, prop up the right side of the machine a few inches. Insert front rod (C) up through bottom of deck, into screen mounting hole, and out through the top of the deck. Test that the rod is through the screen by pulling on the screen – the screen should not move. Secure rod with hair pin clip (D).
4. Insert rear rod (B) up through bottom of deck, into the screen mounting hole, and out through the top of the deck. Make sure that the rod is in the screen by trying to move the screen from side to side. Secure the rod with the hair pin clip (D).
5. Re-install the collection bag.

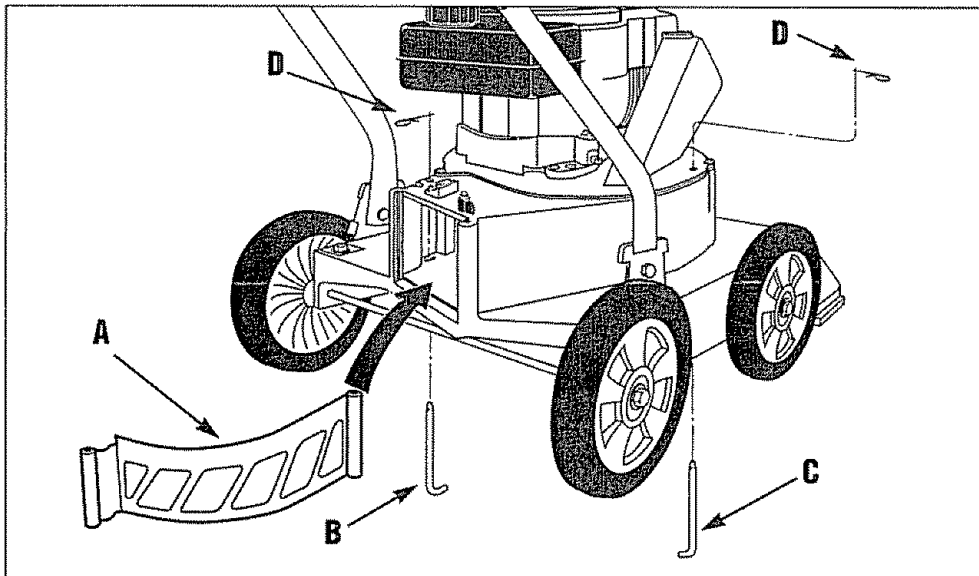

Figure 3: Shredder screen installation.

# ASSEMBLY



## CAUTION

- Check the collection bag frequently for deterioration and wear and replace worn bags.

### STEP 2: INSTALL COLLECTION BAG

For walk-behind vacuuming or using the chipper, install the collection bag as described below.

1. **Stop the engine, disconnect the spark plug wire from the spark plug, and make sure that all moving parts have come to a complete stop.**
2. Make sure the bag (A in Figure 4) is zipped.
3. Place the collection bag straps over the handlebars.
4. Line up the tabs on the bag inlet adapter (B) with the slots in the discharge opening (C) and slide the bag inlet adapter down all the way into the slots. Turn the retaining knob (F) until the tab on the knob drops into the slot on the top of the bag inlet adapter.

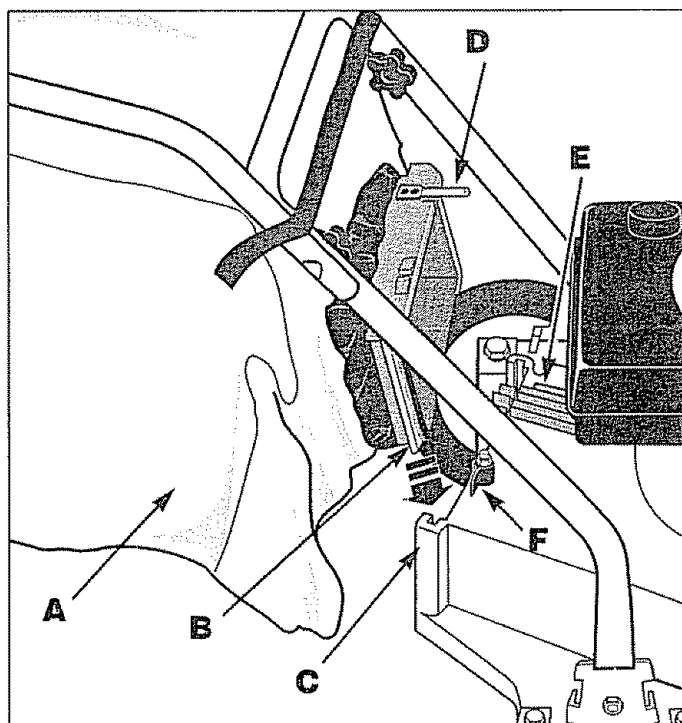

Figure 4: Install collection bag.

NOTE: The rod (D) on the inlet adapter is part of the machine's safety interlock system. Make sure that the rod fits securely in the slot in the safety interlock switch (E).

**BAG MAINTENANCE TIP:** Keep the bag clean by occasionally washing it (by hand) with mild soap and water. A clean bag improves air flow and results in better vacuuming performance. Do not wash the bag in an automatic washer. Do not use a cleaner which contains bleach. Allow the bag to dry thoroughly before storing.

### STEP 3: ADJUST THE VACUUM INLET HEIGHT

The vacuum inlet height can be adjusted to six different settings in approximately 1/2" increments. These settings allow inlet suction to be adjusted for varying needs. For example, when vacuuming deep layers of leaves, adjust the vacuum inlet height at the front of the machine to its highest setting as described below (see Figure 5):

1. **Stop the engine, disconnect the spark plug wire from the spark plug, and make sure that all moving parts have come to a complete stop.**
2. Squeeze the adjuster lever (A in Figure 5) toward the wheel to disengage the adjuster pin from the hole in the height adjuster bracket.
3. Rotate the adjuster lever toward the rear (discharge opening) of the machine to raise the height and then release the adjuster lever so that the adjuster pin engages the selected hole in the bracket. Rotate the lever in the opposite direction to lower the inlet height.
4. Be sure that both adjuster levers are adjusted to the same height.

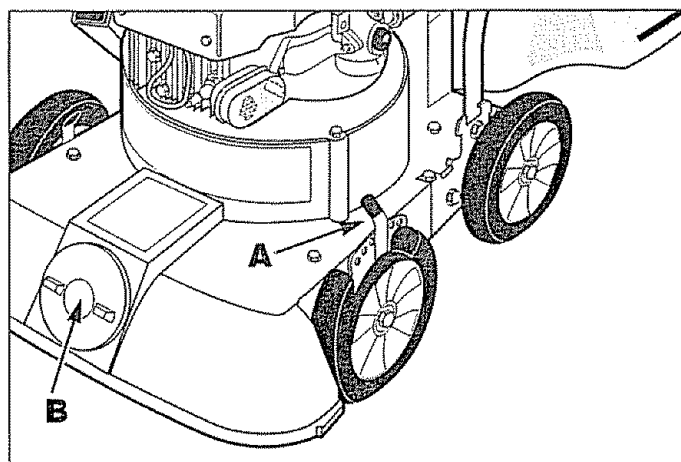

Figure 5: Vacuum Height Adjustment Lever and Inlet Cap.

### STEP 4: INSTALL VACUUM INLET CAP

1. Position the inlet cap (B, Figure 5) so that the bar on the cap is aligned with the arrow at the REMOVE position.
2. Twist the cap 1/4 turn clockwise which will secure the cap in place.

# ASSEMBLY

## ASSEMBLY FOR BLOWER OPERATION



**IMPORTANT:** DO NOT USE THE CHIPPER IF THE MACHINE IS SET UP FOR BLOWER OPERATION.

### STEP 1: REMOVE THE COLLECTION BAG (IF INSTALLED)

1. Stop the engine, disconnect the spark plug wire from the spark plug, and make sure that all moving parts have come to a complete stop.
2. Pull and then turn the retaining knob (F in Figure 6) so that it clears the edge of the bag inlet adapter (B) and the tab rests on the upper housing. Grasp the pull strap and slide the bag inlet adapter (B) out of the slots in the discharge opening (C).
3. Hold the collection bag (A) with the inlet opening upright so that material does not fall out, and slide the straps off the handlebars.
4. Unzip the collection bag and empty it by shaking the bag gently to remove all debris.

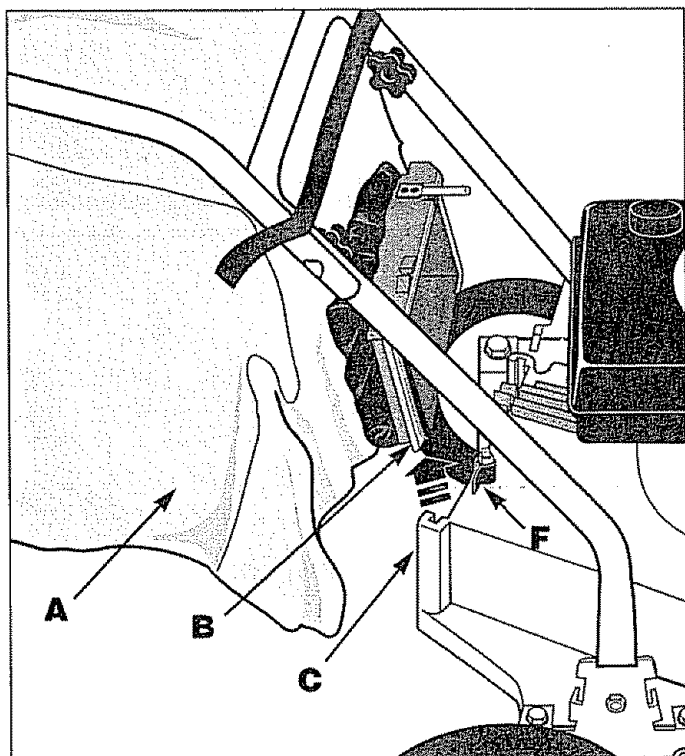

Figure 6: Remove collection bag.

### STEP 2: ADJUST HANDLEBARS

If the handlebars are in the vacuum position, they must be adjusted to the "blower" position for blower operation.

1. Squeeze the handlebar end (see decal "Push in Here") toward the center of the machine and swing the handlebars over to the front of the machine.
2. Release the handlebars ends in the "blower" notches (A). See Figure 7.

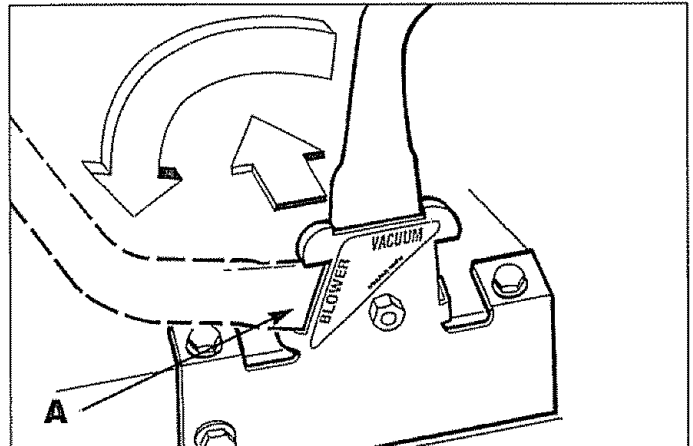

Figure 7: Adjust handlebars to "blower" position.

### STEP 3: ADJUST THE VACUUM INLET HEIGHT

For best results, adjust the vacuum inlet to its highest position for operating the blower. Instructions for making this adjustment are provided on Page 11.

# ASSEMBLY

## STEP 4: REMOVE THE SHREDDER SCREEN

For maximum air flow, remove the shredder screen before installing the blower deflector.

1. The screen (A) is held in place by two long rods (B and C) and hair pin clips (D). See Figure 8.
2. To remove the rear rod (B), remove the hair pin clip (D) and pull the rod out through the bottom of the deck.
3. Use sturdy supports to prop up the right side of the machine a few inches. Then, remove the hair pin clip and pull the rod (C) out through the bottom of the deck.
4. Pull screen (A) out of the discharge opening. Re-install the rods and hair pin clips on the screen for safe-keeping.

**IMPORTANT:** THE HAIR PIN CLIPS SUPPLIED WITH THE SCREEN ARE THE ONLY STYLE FASTENERS THAT SHOULD BE USED. DO NOT USE SUBSTITUTES OR FAILURE OF EQUIPMENT OR PERSONAL INJURY COULD RESULT.

5. Remove the supports from beneath unit.

## STEP 5: INSTALL BLOWER DEFLECTOR

Position the tabs on the sides of the blower deflector (A in Figure 9) into the slots in the discharge opening (B) and slide the blower deflector down all the way into the slots. Turn retaining knob (D) until the tab on the knob drops into the slot on the blower deflector. (Reverse this procedure when removing the blower deflector.)

**NOTE:** The rod (C) on the blower deflector is part of the machine's safety interlock system. Make sure that the rod fits securely in the slot in the safety interlock switch (E).

## STEP 6: INSTALL VACUUM INLET CAP

1. Position the inlet cap (A, Figure 10) so that the bar on the cap is aligned with the arrow at the REMOVE position.
2. Twist the cap 1/4 turn clockwise which will secure the cap in place.

**IMPORTANT:** THE VACUUM INLET CAP MUST BE INSTALLED DURING BLOWER OPERATION.

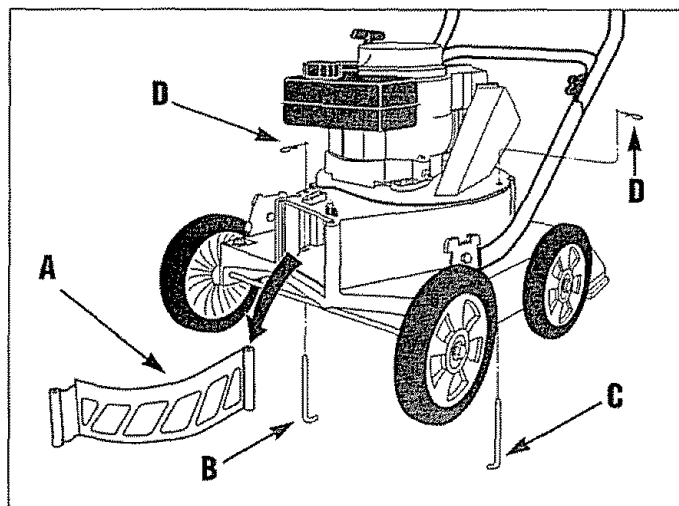

Figure 8: Shredder screen removal.

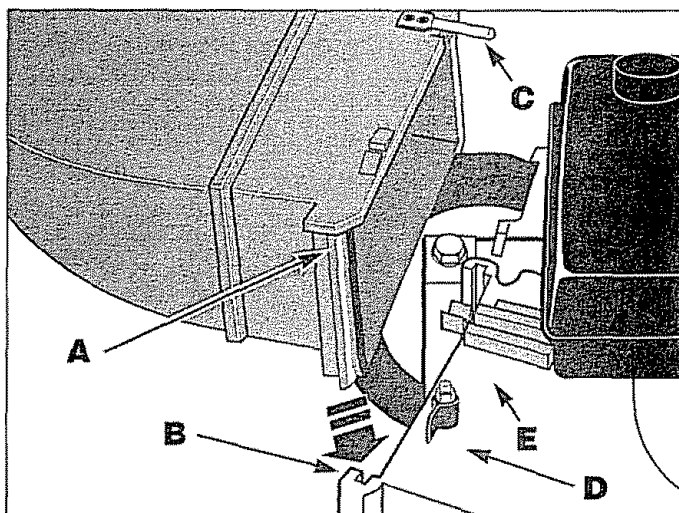

Figure 9: Install blower deflector.

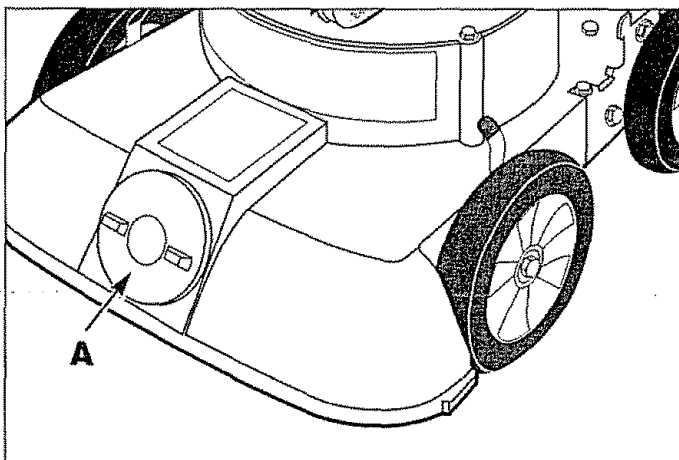
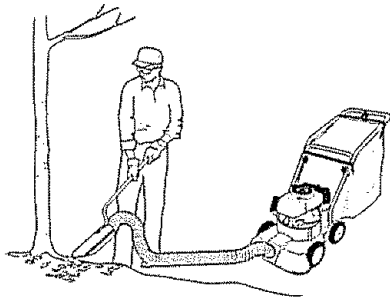

Figure 10: Vacuum Inlet Cap installed.

# ASSEMBLY

## ASSEMBLY FOR OPTIONAL VACUUM HOSE OPERATION



NOTE: The optional Vacuum Hose is designed for stationary vacuuming operation only.

### STEP 1: MOVE HANDLEBARS TO VACUUMING POSITION

1. Stop the engine, disconnect the spark plug wire from the spark plug, and make sure that all moving parts have come to a complete stop.
2. Squeeze the handlebar end (A in Figure 11 inset with decal "Push in Here") toward the center of the machine to release end from the notch in the mounting bracket and swing the handlebars up over the machine toward the rear.
3. Position the handlebar ends in the "vacuum" notches of the brackets (B in Figure 11 inset).

### STEP 2: REMOVE BLOWER DEFLECTOR (IF INSTALLED)

Turn retaining knob (D in Figure 12) until the tab on the knob is out of the slot in the blower deflector. Pull the sides of the blower deflector (A in Figure 12) out of the slots in the discharge opening (B) and slide the blower deflector off the machine.

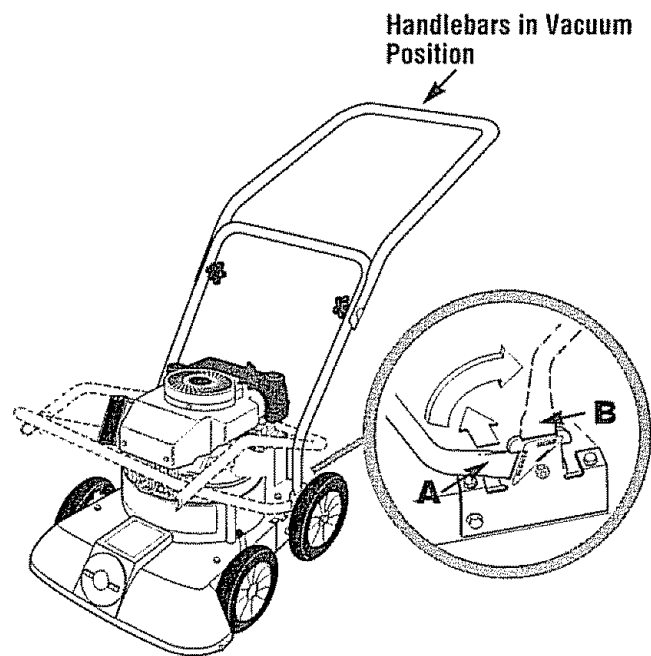

Figure 11: Handlebar position for vacuuming.

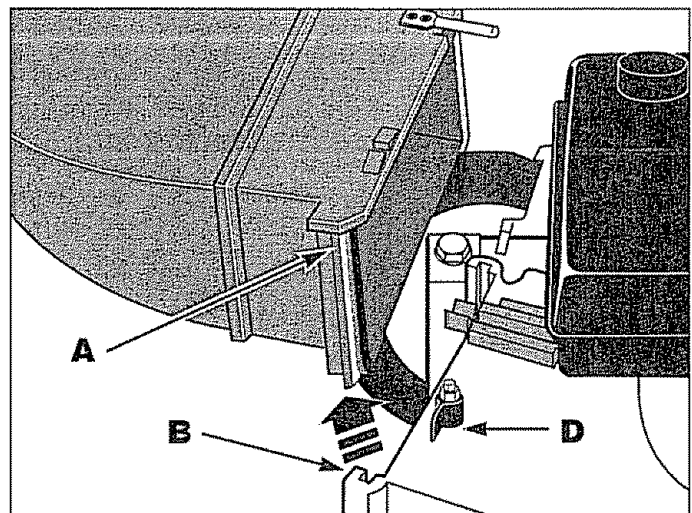

Figure 12: Remove blower deflector.

# ASSEMBLY

## STEP 3: REMOVE THE SHREDDER SCREEN

For maximum air flow, remove the shredder screen before installing the vacuum hose.

1. The screen (A) is held in place by two long rods (B and C) and hair pin clips (D) (see Figure 13).
2. To remove the rear rod (B), remove the collection bag (if installed). Then, remove the hair pin clip and pull the rod out through the bottom of the deck.
3. Use sturdy supports to prop up the right side of the machine a few inches. Then, remove the hair pin clip and pull the rod (C) out through the bottom of the deck.
4. Pull the screen out of the discharge opening. Re-install the rods and hair pin clips on the screen for safe-keeping.

**IMPORTANT:** THE HAIR PIN CLIPS SUPPLIED WITH THE SCREEN ARE THE ONLY STYLE FASTENERS THAT SHOULD BE USED. DO NOT USE SUBSTITUTES OR FAILURE OF EQUIPMENT OR PERSONAL INJURY COULD RESULT.

5. Remove the supports from beneath the machine.

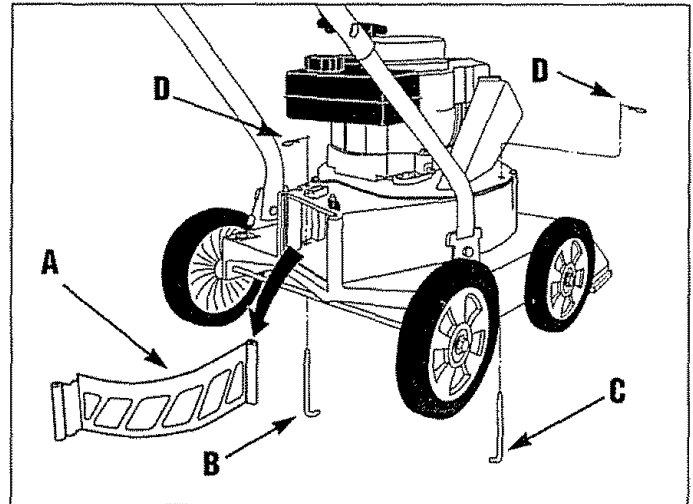

Figure 13: Shredder screen removal.

## STEP 4: INSTALL COLLECTION BAG

### CAUTION

- Check the collection bag frequently for deterioration and wear and replace worn bags.

For using the vacuum hose, install the collection bag as described below.

1. Make sure the bag (A in Figure 14) is zipped.
2. Place the collection bag straps over the handlebars.
3. Line up the tabs on the bag inlet adapter (B) with the slots in the discharge opening (C) and slide the bag inlet adapter down all the way into the slots. Turn the retaining knob (F) until the tab on the knob drops into the slot on the top of the inlet adapter.

**NOTE:** The rod (D) on the inlet adapter is part of the machine's safety interlock system. Make sure the rod fits securely in the slot in the safety interlock switch (E).

**BAG MAINTENANCE TIP:** Keep the bag clean by occasionally washing it (by hand) with mild soap and water. A clean bag improves air flow and results in better vacuuming performance. Do not wash the bag in an automatic washer. Do not use a cleaner which contains bleach. Allow the bag to dry thoroughly before storing.

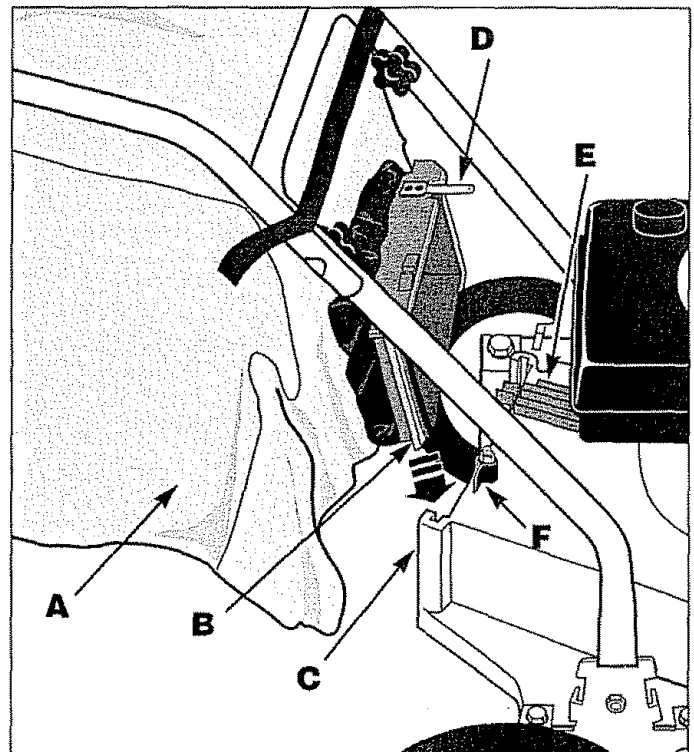

Figure 14: Install collection bag.

# ASSEMBLY

## STEP 5: INSTALL BAFFLE PLATE

The baffle plate, which is included only with the optional vacuum hose, concentrates the suctioning power of the machine into the hose by blocking the air flow underneath the front of the machine. To install the baffle plate, position the plate underneath the front of the deck and snap it into place as shown in Figure 15.

### Baffle Plate Removal

To remove the baffle plate, grasp the tabs on each side of the plate, press outward, and remove the plate.

## STEP 6: REMOVE VACUUM INLET CAP AND INSTALL HOSE

1. Remove the vacuum inlet cap (**A**, Figure 16) by twisting the cap counterclockwise approximately 1/4 turn until the bar on the cap is aligned with the arrow at the **REMOVE** position. Lift the cap off the inlet opening. **Do not misplace the vacuum inlet cap.**
2. Line up the tabs on the hose (**B**) with the slots in the vacuum inlet opening and insert the hose. Turn the hose approximately 1/4 turn clockwise until it is in the **LOCK** position. See Figure 16. (The hose support handle should now be on the top of the hose.)
3. The machine is now properly assembled for use with the vacuum hose.

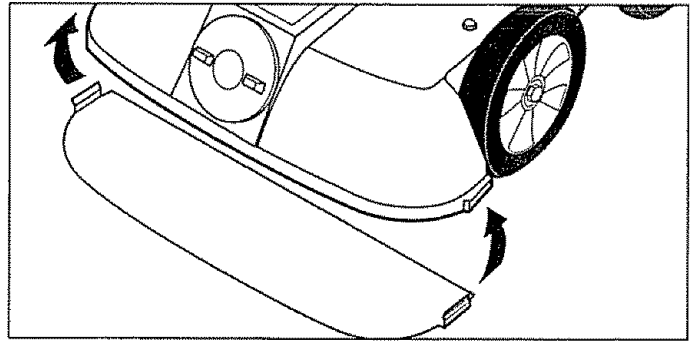

Figure 15: Install the baffle plate.

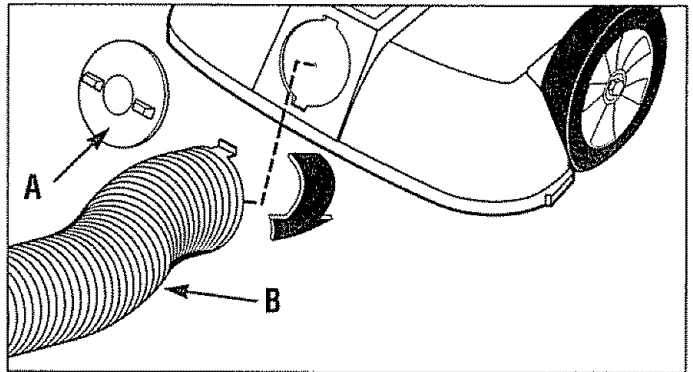

Figure 16: Remove vacuum inlet cap and install vacuum hose.

# OPERATION

## KNOW YOUR CHIPPER/VAC

READ THIS OWNER'S MANUAL AND SAFETY RULES BEFORE OPERATING YOUR CHIPPER/VAC. Figure 17 identifies the following key features and controls on your machine:

- (A) COLLECTION BAG: Used to collect material resulting from vacuuming or chipping operation.
- (B) ENGINE CONTROL LEVER: Used to control the speed of the engine.
- (C) ENGINE PRIMER: Provides additional fuel from the carburetor to the cylinder for use when starting a cold engine.
- (D) AIR CLEANER: Filters dirt which could damage engine parts.
- (E) CHIPPER CHUTE: Used to process small branches.
- (F) FUEL TANK: Stores engine fuel.

- (G) RECOIL STARTER ROPE: Used to start the engine.
- (H) BLOWER DEFLECTOR: Directs air flow when machine is used in blower configuration.
- (I) SAFETY INTERLOCK ROD: Part of the safety interlock system which stops the engine if either the collection bag or blower deflector is not installed.
- (J) VACUUM HOSE (OPTIONAL): Used for remote vacuuming.
- (K) BAFFLE PLATE: Used with optional vacuum hose.
- (L) VACUUM INLET CAP: Covers vacuum hose inlet when machine is used for walk-behind vacuuming or chipping.
- (M) SPARK PLUG: Provides spark for engine ignition.
- (N) VACUUM HEIGHT ADJUSTMENT LEVER: Allows adjustment of the space between the bottom of the machine and the ground.

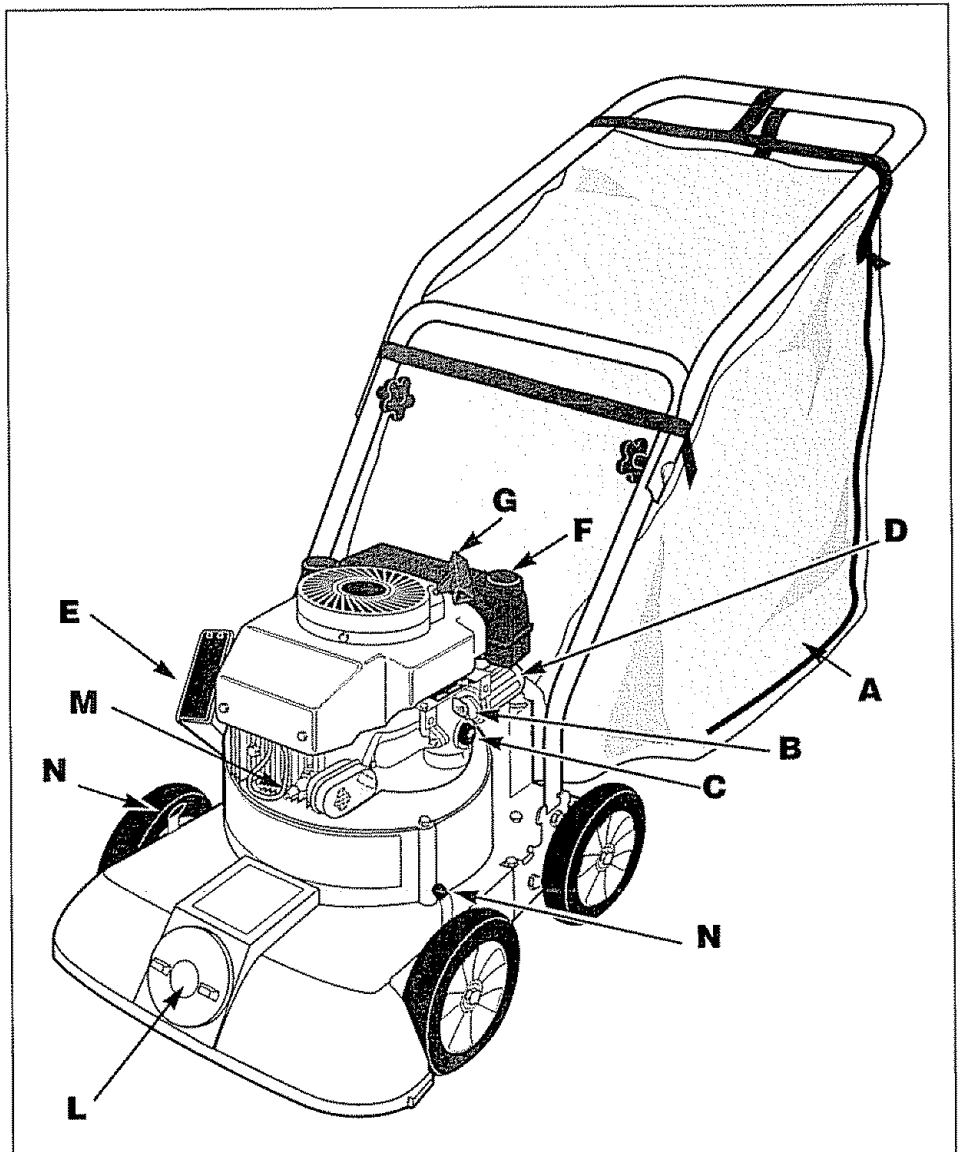
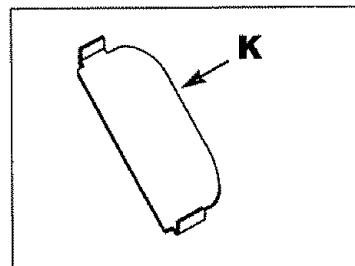
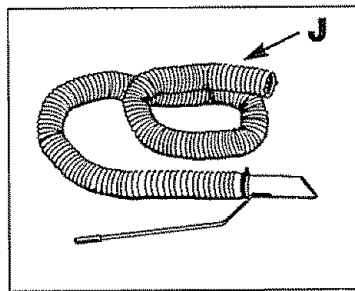
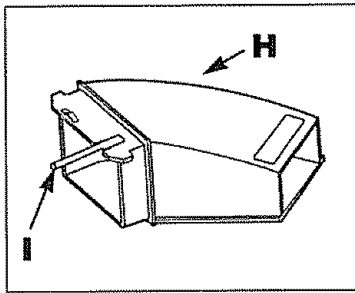

Figure 17: Features and Controls.

# OPERATION

## BEFORE STARTING ENGINE

### STEP 1: ADD OIL TO ENGINE

1. *The machine was shipped without oil in the engine.* The engine requires approximately 21 ounces of oil.

2. Only use high quality detergent oil rated with the A.P.I. service classification of "SF" or "SG". Select the oil's SAE viscosity grade according to your expected operating temperature:

NOTE: Change the oil after the first two operating hours. See "Changing Oil" on Page 27 in the "Customer Responsibilities" section of this Manual.

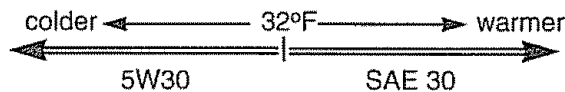

NOTE: Although multi-viscosity oils (5W30, 10W30, etc.), improve starting in cold weather, these multi-viscosity oils will result in increased oil consumption when used above 32°F. Check your engine oil level more frequently to avoid possible engine damage from running low on oil.

3. With the machine on level ground, remove the dipstick (A, Figure 18) and place it on a clean surface.

4. Using a clean funnel, slowly add oil to the dipstick hole. While adding oil, frequently reinstall dipstick (screw dipstick down securely) to check oil level. Wipe dipstick with a clean cloth before reinserting each time. Fill to the "FULL" mark on dipstick. **DO NOT OVERFILL!**

5. Reinstall the dipstick securely.

### STEP 2: ADD GASOLINE TO THE FUEL TANK

Fill the fuel tank with fresh, clean, unleaded regular automotive gasoline. (Leaded regular and unleaded premium grades of gasoline are acceptable substitutes.)

- Do not mix oil with gasoline.
- Do not use gasoline left over from last season or stored for long periods.

**WARNING:** Experience indicates that alcohol blended fuels (called gasohol or using ethanol or methanol) can attract moisture which leads to separation and formation of acids during storage. Acidic gas can damage the fuel system of an engine while in storage.

To avoid engine problems, the fuel system should be emptied before storage for 30 days or longer. Drain the gas tank, start the engine and let it run until the fuel lines and carburetor are empty. Use fresh fuel next season. See STORAGE instructions for additional information.

Never use engine or carburetor cleaner products in the fuel tank or permanent damage may occur.



### DANGER

Rotating Cutting Blades Will Cause Serious Personal Injury!

Do not allow hands or any part of the body or clothing inside the vacuum inlet, chipper chute, discharge opening, or blower deflector opening when the engine is running.

Before inspecting or servicing any part of the machine, stop the engine and make sure that all moving parts have come to a complete stop. Disconnect the spark plug wire and secure it away from the spark plug.

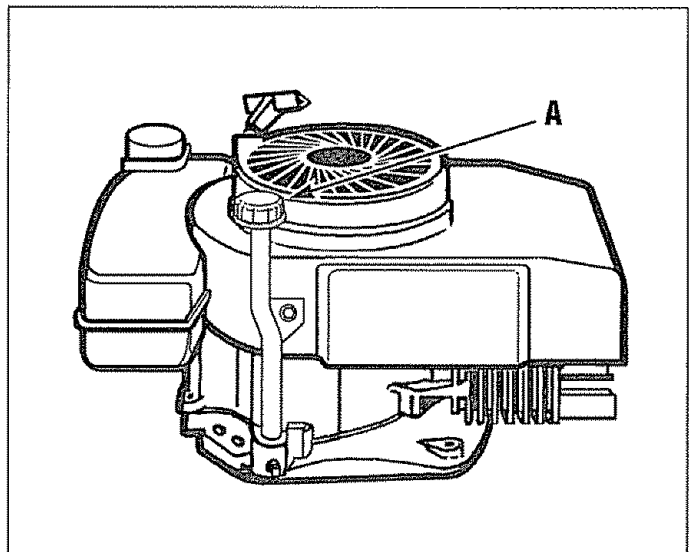

Figure 18: Remove dipstick to add oil to engine.



### DANGER

Gasoline is highly flammable and its vapors are explosive. To prevent personal injury or property damage:

- Do not add fuel if the engine is running or still hot from recent operation. Allow the engine to cool for at least three minutes.
- Do not fill the fuel tank indoors. After filling, wipe up any spills and move the machine away from gasoline fumes before starting the engine.
- Do not allow open flames, matches, or smoking in area.

# OPERATION

## To Add Gasoline

1. **Stop the engine and wait for all moving parts to come to a complete stop. Disconnect the spark plug wire and secure it away from the spark plug. Allow the engine and muffler to cool for at least three minutes.**
2. Clean area around fuel fill cap and remove cap (A in Figure 19) from fuel tank.
3. Use a clean funnel to fill the fuel tank to 1/2 inch below the bottom of the filler neck (to provide room for fuel expansion).
4. Re-install the fuel fill cap securely and wipe up any spilled gasoline.

## PRE-STARTING PROCEDURES

**IMPORTANT:** REVIEW THE SAFETY SECTION AND READ THIS SECTION IN ITS ENTIRETY BEFORE STARTING THE ENGINE.

With the spark plug wire disconnected from the spark plug, perform the following pre-starting procedures as required before each start-up:

- Place the machine outdoors on level ground.
- Make sure you are wearing safety goggles (and heavy work gloves if using the chipper).
- Be sure that all bystanders are at least 25 feet away from the area of operation.
- Check that the chipper chute, vacuum inlet, or discharge deflector are empty (after initial use of the machine).
- Check that all screws, nuts, bolts, and other fasteners are properly secured.
- Check the oil level in the engine.
- Re-attach the spark plug wire before starting the engine.

## SAFETY INTERLOCK SYSTEM

Your machine is equipped with a Safety Interlock System which prevents the engine from starting unless the collection bag (or blower deflector) is installed. The rod (A, Figure 20) must be positioned as shown in slot (B) in order to start the engine.

The system also stops the engine if the operator attempts to remove the bag or blower deflector while the engine is running. When the rod is not in place, a circuit closes to ground out the engine.

If the safety interlock system fails, shut off the engine and do not operate the machine until the system has been repaired. Contact your local Sears service center for repairs.



## WARNING

To avoid personal injury or property damage, do not operate this machine unless the safety interlock system is functioning properly.

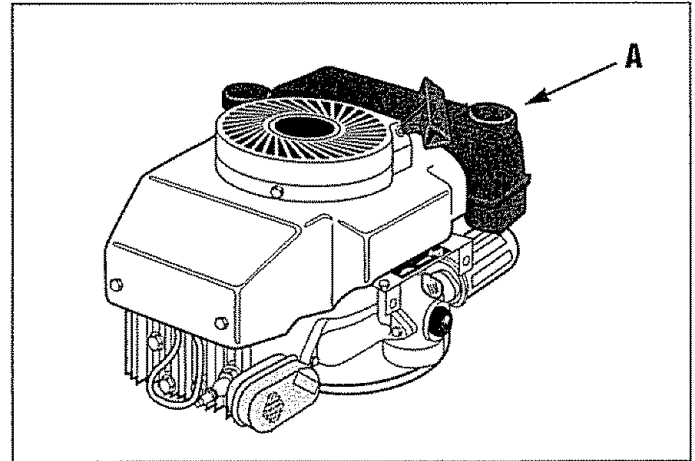

Figure 19: Fill fuel tank.



## DANGER

To Prevent Personal Injury or Property Damage:

- Cutting blades begin to rotate when the engine starts and slow down gradually after the engine is shut off. Do not allow hands or any other part of the body or clothing inside the vacuum inlet, chipper chute, discharge opening, blower deflector opening, or near any moving part.
- Do not run the engine in an enclosed area. Engine exhaust contains carbon monoxide gas, a deadly poison that is odorless, colorless and tasteless. Do not operate this equipment near buildings, windows, or air conditioners.

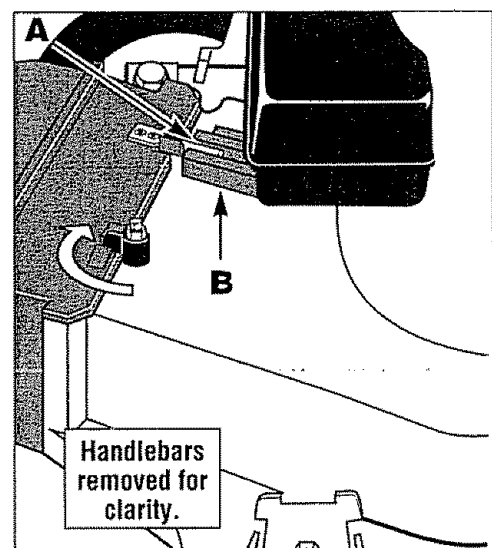

Figure 20: Safety Interlock System.

# OPERATION

## GENERAL OPERATION

Understanding how your machine works will help you achieve the best results when using the Chipper/Vac. Read the following explanation before using the machine and see Figure 21 which shows the internal workings of the Chipper/Vac.

- (A) Chipper Chute
- (B) Chipper Cutting Blade
- (C) Shredder Screen
- (D) Processing Chamber
- (E) Fan Blade (1 of 4)
- (F) Discharge Opening

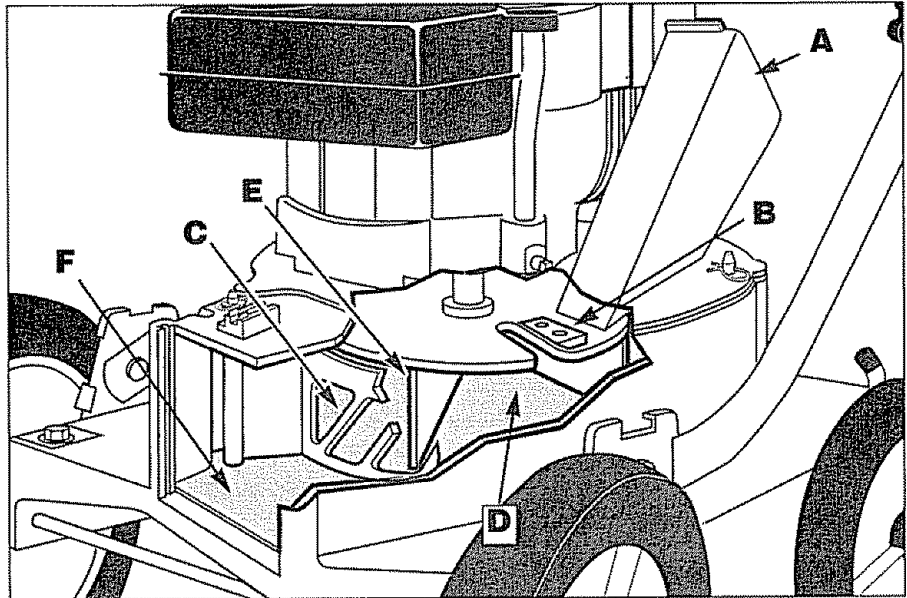

Figure 21: Cutaway view. (Blower deflector removed for clarity.)

## STARTING THE ENGINE

1. Put on safety goggles and work gloves. Do not wear loose fitting clothing or jewelry that can get caught in moving parts.
  2. Move the Engine Control Lever (A, Figure 22) all the way to the **right** (toward rabbit position) until it stops.
  3. When starting a cold engine, **firmly** push primer (B, Figure 22) five (5) times before trying to start the engine. (This step is not required when starting an engine which has already run for a few minutes.)
  4. Stand at the left front of the machine. Place one foot against left front wheel to stabilize the machine.
  5. Look behind you to make sure there are no obstacles in the way. Grasp the Starter Rope Handle (C) and pull handle quickly. Do not allow starter rope to snap back.
- NOTE: In cool weather, repeat priming step if necessary. In warm weather, over priming may cause flooding so that the engine will not start. If the engine is flooded, wait a few minutes before attempting to start it and **do not** repeat the priming step.
6. Leave the Engine Control Lever at the FAST (rabbit) setting.
- FAST is the recommended setting for all vacuuming and chipping operations.

## STOPPING THE ENGINE

1. Move the Engine Control Lever all the way to the **left** (toward turtle position) until it stops.
2. Listen for all moving parts to come to a complete stop. There is an audible tone when the cutting blades are slowing down.

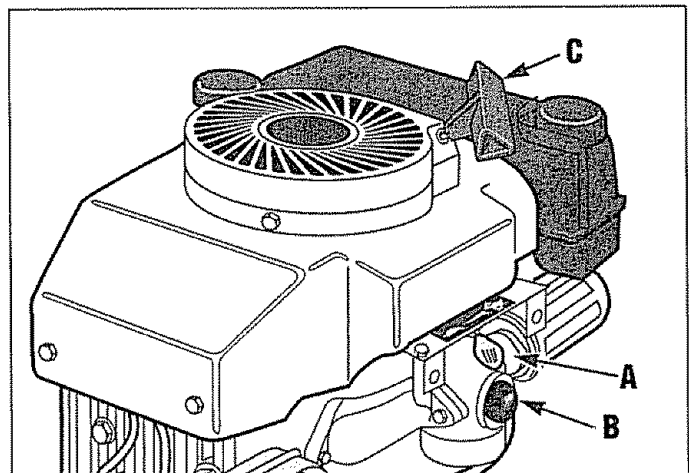

Figure 22: Starting and stopping the engine.

# OPERATION

## VACUUMING OPERATION

Vacuumping operation begins in the processing chamber where the blades attached to the flywheel spin at up to 3600 RPM, creating a powerful suction. Material enters the processing chamber from beneath the machine during walk-behind vacuuming and during use of the blower deflector. Material enters from the hose during use of the vacuum hose. The material is then processed through the chamber (and screen if installed) and exits from the discharge opening into the collection bag or is propelled out through the blower deflector.

## CHIPPING OPERATION

Chipping operation also takes place in the processing chamber. Branches fed down through the chipper chute enter the processing chamber where a hardened steel chipper blade, mounted on the spinning flywheel, slices the material into small chips. The chips are then propelled out from the processing chamber through the discharge opening into the collection bag.

## VACUUMING AND CHIPPING GUIDE

The chart below lists some commonly available materials that can be processed using your Chipper/Vac. This chart is only intended as a general guideline. For complete vacuuming and chipping operating instructions, please read this entire Operation Section.

MATERIAL	WALK-BEHIND VACUUMING or BLOWER DEFLECTOR	VACUUM HOSE	CHIPPER
Dry leaves	Yes (1)	Yes (2)	No
Damp leaves	Yes (1,2)	Yes (2)	No
Acorns & pine needles	Yes (2,3)	Yes (2)	No
Grass clippings	Yes (1,2)	Yes (2)	No
Vines	No	No	Yes (cut into very short lengths)
Cornstalks	No	No	Yes (cut off root ball)
Small branches (1-1/2" max. dia.)	No	No	Yes
Light brush	No	No	Yes

- 1 - Adjust vacuum inlet height up or down as needed for walk-behind vacuuming.
- 2 - Remove the shredder screen to prevent clogging and improve air flow.
- 3 - Remove screen and adjust vacuum inlet height to lowest position.

## MATERIALS TO AVOID

- METAL
- ROCKS
- GLASS
- PLASTIC
- OTHER NON-ORGANIC FOREIGN OBJECTS
- DIRT & SAND (WILL QUICKLY DULL CHIPPER BLADE)
- STICKS AND TWIGS (WILL CLOG VACUUM INLET OR HOSE - PLACE IN CHIPPER CHUTE ONLY)

# OPERATION

## WALK-BEHIND VACUUMING OPERATION

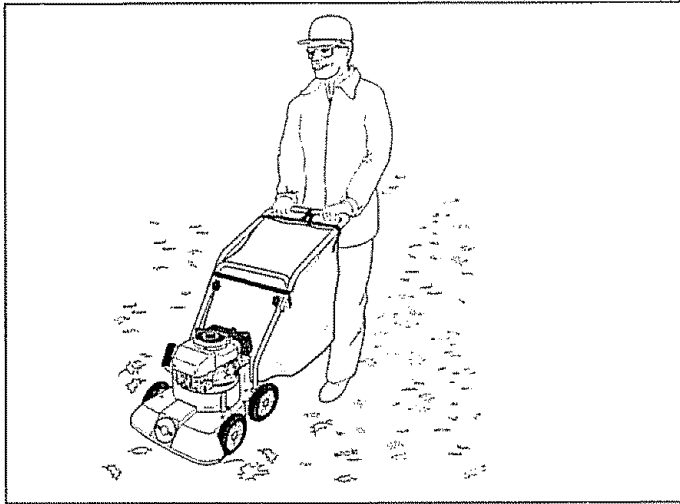

Figure 23: Machine prepared for walk-behind vacuuming.

### Operation

1. Prepare the unit for vacuuming by following the assembly steps on Page 10.
2. Walk slowly behind the machine to allow the machine to draw the debris off the ground.
3. In certain conditions it may be necessary to make two passes over the area.
4. Be sure to frequently empty the collection bag. See Step 1 on Page 12.
5. To stop the machine, move the Engine Control Lever all the way to the **left** (toward turtle position) until it stops.
6. Listen for all moving parts to come to a complete stop. There is an audible, distinct sound produced as the cutting blades slow down. Wait for this sound to stop before inspecting, servicing, or changing the operating mode of the machine.

### Walk-Behind Vacuuming Tips and Hints

- Avoid overfilling the vacuum inlet which can lead to clogging, especially if the material is wet and soggy. A steady, smaller flow of materials provides the most effective results.
- Work from the outer edge of leaf piles and gradually work inward.
- Mow the lawn before the leaves fall to make vacuuming easier. Keeping your lawn a bit shorter in the Fall will help a great deal.**
- Check and empty the collection bag frequently.
- If possible, vacuum frequently to avoid deep piles of leaves from accumulating on the lawn.
- Use care when vacuuming near plantings, ornamentals, mulches, stone or gravel.
- Use the blower deflector to blow the leaves into long rows before walk-behind vacuuming if the leaf cover is sparse.
- Avoid vacuuming long twigs and sticks which are likely to jam or clog the vacuum inlet. Instead, process twigs and sticks using the chipper chute as described on Page 25.

**IMPORTANT:** IF THE MACHINE JAMS OR CLOGS, IMMEDIATELY SHUT OFF THE ENGINE AND DISCONNECT THE SPARK PLUG WIRE FROM THE SPARK PLUG. REFER TO PAGE 26 FOR SAFETY PRECAUTIONS AND DETAILED INSTRUCTIONS ON HOW TO REMOVE JAMS AND CLOGS.



### DANGER

To Prevent Personal Injury or Property Damage:

- Cutting blades begin to rotate when the engine starts and slow down gradually after the engine is shut off. Do not allow hands or any other part of the body or clothing inside the vacuum hose opening, blower discharge opening, chipper chute, or near any moving part.
- Before inspecting, cleaning, or servicing the machine, stop the engine and make sure that all moving parts have come to a complete stop. Disconnect the spark plug wire and secure it away from the spark plug.
- To avoid personal injury or property damage, do not operate this machine for vacuuming unless the collection bag is installed.
- Review all of the rules in the Safety Section of this Manual.

### IMPORTANT

#### Spring Operation:

Spring clean-up can be especially difficult! Leaves and other debris may have matted down over the preceding months. For best results when vacuuming this type of debris: remove the screen, lower the vacuum inlet, and walk slowly. You can even use the machine as you would a vacuum cleaner, moving it back and forth over particularly stubborn debris, or loosen the debris with a few quick passes of a rake, and then vacuum.

#### Fall Operation:

Don't try to vacuum too much at one time! Optimum performance is obtained when leaves are vacuumed once a week, or even more often at the peak of leaf-drop. Keep ahead of the leaves. In the long run, this is the easiest and fastest way to deal with all of your Fall leaves.

# OPERATION

## VACUUM HOSE OPERATION

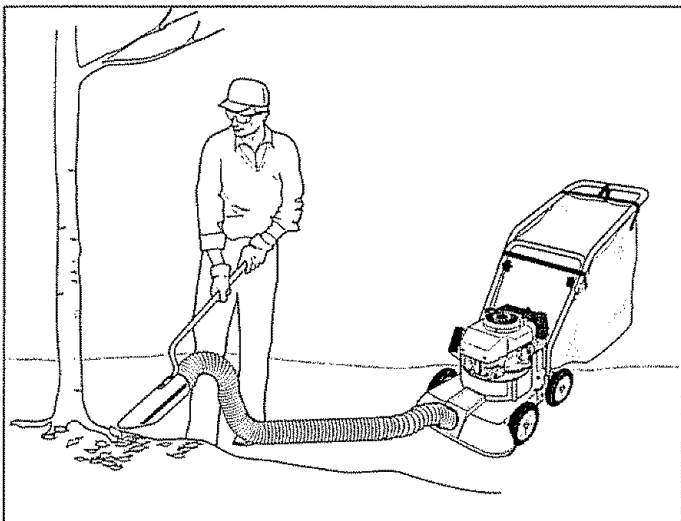

Figure 24: Using the vacuum hose.

NOTE: The optional Vacuum Hose is designed for stationary vacuuming operation only.

### OPERATION

1. Prepare the unit for use of the vacuum hose by following the assembly steps on Page 14.
2. Move the machine to the vacuuming site and park the machine on level ground.

NOTE: To avoid damaging the hose, drape the hose to the right side of the machine when moving the machine between vacuuming sites. Do not allow the hose to touch the engine.

3. Use the handle attached to the hose to easily maneuver the hose around corners, underneath bushes, etc. See Figure 24.
4. To stop the machine, move the Engine Control Lever all the way to the **left** (toward turtle position) until it stops.
5. Empty the collection bag frequently when using the vacuum hose. See Page 12 for instructions.
6. Listen for all moving parts to come to a complete stop. There is an audible, distinct sound produced as the cutting blades slow down. Wait for this sound to stop before inspecting, servicing, or changing the operating mode of the machine.



### DANGER

To Prevent Personal Injury or Property Damage:

- Cutting blades begin to rotate when the engine starts and slow down gradually after the engine is shut off. Do not allow hands or any other part of the body, or clothing inside the vacuum hose opening, blower discharge opening, chipper chute, or near any moving part.
- Before inspecting, cleaning, or servicing the machine, stop the engine and make sure that all moving parts have come to a complete stop. Disconnect the spark plug wire and secure it away from the spark plug.
- To avoid personal injury or property damage, do not operate this machine for vacuuming unless the collection bag is installed.
- Review all of the rules in the Safety Section of this Manual.

### Tips for Using the Vacuum Hose

- When vacuuming, move the hose **slowly** from side to side.
- To avoid clogging, do not vacuum too much material at once. Vacuum some material, let the hose "breathe," and then vacuum some more.
- Also keep the hose as straight as possible to prevent clogging.
- Do not attempt to move the machine by pulling on the hose. This could damage the hose and cause the machine to move unsafely.

**IMPORTANT:** IF THE MACHINE JAMS OR CLOGS, IMMEDIATELY STOP THE ENGINE AND MAKE SURE THAT ALL MOVING PARTS HAVE COME TO A COMPLETE STOP. DISCONNECT THE SPARK PLUG WIRE AND SECURE IT AWAY FROM THE SPARK PLUG. REFER TO PAGE 26 FOR SAFETY PRECAUTIONS AND DETAILED INSTRUCTIONS ON HOW TO REMOVE JAMS AND CLOGS.

# OPERATION

## BLOWER OPERATION

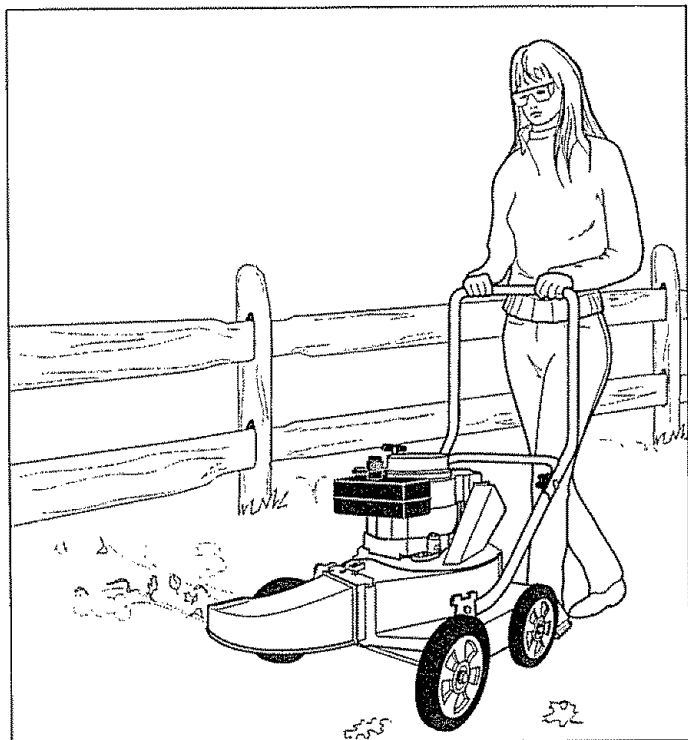

Figure 25: Blower operation.

### OPERATION

1. Prepare the unit for blower operation by following the assembly steps on Page 12.
2. Blower Operation begins in the processing chamber where fan blades attached to the flywheel create a suction which draws air from underneath the machine. Air flows through the chamber and is propelled out through the blower deflector.
3. To stop the machine, move the Engine Control Lever all the way to the *left* (toward turtle position) until it stops.
4. Listen for all moving parts to come to a complete stop. There is an audible, distinct sound produced as the cutting blades slow down. Wait for this sound to stop before inspecting, servicing, or changing the operating mode of the machine.



### DANGER

To Prevent Personal Injury or Property Damage:

- Cutting blades begin to rotate when the engine starts and slow down gradually after the engine is shut off. Do not allow hands or any other part of the body or clothing inside the vacuum hose opening, blower discharge opening, chipper chute, or near any moving part.
- Before inspecting, cleaning, or servicing the machine, stop the engine and make sure that all moving parts have come to a complete stop. Disconnect the spark plug wire and secure it away from the spark plug.
- To avoid personal injury or property damage, keep clear of the blower discharge area. Material exits at high speed from the blower deflector.
- Review all of the rules in the Safety Section of this Manual.

**IMPORTANT:** DO NOT USE THE CHIPPER IF THE MACHINE IS SET UP FOR BLOWER OPERATION. THE VACUUM INLET CAP MUST BE INSTALLED DURING BLOWER OPERATION.

**IMPORTANT:** IF THE MACHINE JAMS OR CLOGS, IMMEDIATELY STOP THE ENGINE AND MAKE SURE THAT ALL MOVING PARTS HAVE COME TO A COMPLETE STOP. DISCONNECT THE SPARK PLUG WIRE AND SECURE IT AWAY FROM THE SPARK PLUG. REFER TO PAGE 26 FOR SAFETY PRECAUTIONS AND DETAILED INSTRUCTIONS ON HOW TO REMOVE JAMS AND CLOGS.

# OPERATION

## CHIPPER OPERATION



Figure 26: Using the chipper.

Feed small branches into the chipper chute. Branches are processed by the chipper blade and discharged into the collection bag.

1. If the machine was previously used for vacuuming, it is correctly assembled for using the chipper. **If the machine was used for blower operation, it must be adjusted to the walk-behind vacuuming position before using the chipper. See assembly steps on Page 10.**

**IMPORTANT: THE CHIPPER IS IN OPERATING MODE WHENEVER THE ENGINE IS RUNNING. BE SURE TO WEAR WORK GLOVES WHEN FEEDING MATERIAL INTO THE CHIPPER CHUTE**

2. Stand at the side of the machine, and carefully feed small branches and twigs (up to 1-1/2 inch in diameter) into the chipper chute. See Figure 26 which shows chipper operation.

3. Guide the branch down until your hands approach the top of the chute. Note that there is a flap at the top of the chipper chute. **NEVER PUT YOUR HANDS DOWN PAST THE CHIPPER CHUTE FLAP.**

**IMPORTANT: DO NOT OPERATE THE CHIPPER IF THE CHIPPER FLAP IS WORN OR MISSING**

4. Feed the branch slowly. If the machine labors, pull the branch upward until the engine regains speed. Continue to alternately feed and retract the branch until your hands approach the top of the chipper chute and then **let go.**

**IMPORTANT: IF THE MACHINE JAMS OR CLOGS, IMMEDIATELY STOP THE ENGINE AND MAKE SURE THAT ALL MOVING PARTS HAVE COME TO A COMPLETE STOP. DISCONNECT THE SPARK PLUG WIRE AND SECURE IT AWAY FROM THE SPARK PLUG. REFER TO PAGE 26 FOR SAFETY PRECAUTIONS AND DETAILED INSTRUCTIONS ON HOW TO REMOVE JAMS AND CLOGS.**



## DANGER

To Prevent Personal Injury or Property Damage:

- Cutting blades begin to rotate when the engine starts and slow down gradually after the engine is shut off. Do not allow hands or any other part of the body or clothing inside the vacuum inlet, chipper chute, discharge deflector or near any moving part.
- Before inspecting, cleaning, or servicing the machine, stop the engine and make sure that all moving parts have come to a complete stop. Disconnect the spark plug wire and secure it away from the spark plug.
- Do not operate the machine unless the chipper chute is securely installed.
- To avoid a fire hazard, keep leaves, grass and other combustible materials away from the engine and muffler.
- Keep bystanders, pets, and children at least 25 feet away from the machine.
- Review all of the safety rules in the Safety Section of this Manual.

5. Do not reach into the chipper chute to retrieve material that is below the flap. If the material jams or clogs the chute, shut off the engine, disconnect the spark plug wire, and wait for all moving parts to stop before attempting to retrieve the material.

- If a branch causes the engine to stall, merely restart. Stalling does not harm the engine.
- Empty the collection bag frequently when using the chipper. Refer to Page 12.

6. To stop the engine, move the Engine Control Lever all the way to the **left** (toward turtle position) until it stops. There is an audible, distinct sound as the cutting blade slows down. Wait for this sound to stop before inspecting, servicing, or changing the operating mode of the machine.

## Tips for Using the Chipper

- Before chipping a large number of branches, remove the shredder screen for faster discharge of the chips into the collection bag.
- Whenever possible, process branches while they are still fresh -- green wood chips more easily than dry wood.

---

# OPERATION

---

## CLEARING JAMS AND CLOGS



### WARNING

Before inspecting, cleaning or servicing the machine, stop the engine and make sure that all moving parts have come to a complete stop. Disconnect the spark plug wire and secure it away from the spark plug. Failure to follow this instruction could result in personal injury.

A clog or jam can cause the vacuuming and discharging operations to decrease or even stop completely. If this occurs, take the following steps:

1. **STOP THE ENGINE IMMEDIATELY and wait for all moving parts to stop. Disconnect the spark plug wire and secure it away from the spark plug.**
2. Check and clean, if necessary, the following areas in the order given.

#### *For all vacuuming operations:*

1. Check that the collection bag is not overfilled.
2. While the bag is removed, check that the discharge opening is not clogged.

#### *For walk-behind vacuuming:*

1. Check that the vacuum inlet opening is not clogged.
2. Use a stick to clear away debris.

#### *For using the blower deflector:*

1. Check that the blower deflector discharge opening is not clogged.
2. Use a stick to clear away debris.

#### *For using the vacuum hose:*

1. Check that the hose is not clogged.
2. Remove the hose and use a long stick to clear away any debris from the vacuum inlet opening.

# CUSTOMER RESPONSIBILITIES

## IMPORTANT SERVICE MESSAGE

Perform the Maintenance Schedule listed in the chart below to ensure the proper performance and long life of your machine.

If you do not wish to service the machine yourself, you can bring it to your local Sears Service Center for expert service.



## CAUTION

Before inspecting, cleaning or servicing the machine, stop the engine and make sure that all moving parts have come to a complete stop. Disconnect the spark plug wire and secure it away from the spark plug.

Failure to follow these instructions can result in personal injury or property damage.

MAINTENANCE SCHEDULE					
SERVICE	Before Each Use	Every 5 Hours	Every 25 Hours	Every 100 Hours	As Noted
Check Engine Oil Level (Page 28)	•	•			
Change Engine Oil (Page 28)			•		1,2
Replace Air Filter (Page 28)					4
Clean Cooling System (Page 28)		•			2
Inspect Spark Arrester (if equipped)					3
Inspect Spark Plug (Page 28)				•	
Clean Machine			•		2
Check Bolts and Nuts (Page 29)	•				

NOTE 1 – Change oil after first two hours of new operation.

NOTE 2 – Service more frequently in extremely dusty or dirty conditions.

NOTE 3 – If engine is equipped with a spark arrester, clean and inspect for damage every 50 operating hours

NOTE 4 – Replace yearly or more often if used in extremely dusty or dirty conditions

## CHECK AND CHANGE ENGINE OIL

- Check oil level every five operating hours and before each use of the machine.
- Change oil after first two hours of new operation and every 25 operating hours thereafter. **IMPORTANT:** Change oil more frequently when operating in extremely dusty or dirty conditions.

### To Check Oil Level

1. Place the machine on level ground. **Stop the engine and make sure that all moving parts have come to a complete stop. Disconnect the spark plug wire and secure it away from the spark plug.**
2. To avoid contaminating the engine oil with dirt, clean the area around the dipstick (A, Figure 27). Remove the dipstick and wipe it with a clean cloth. Screw the dipstick fully inward and then remove it to check the oil level.

3. The oil level should be at the "FULL" mark on the dipstick. If the oil level is low, add recommended oil. After checking or adding oil, install the dipstick and tighten securely.

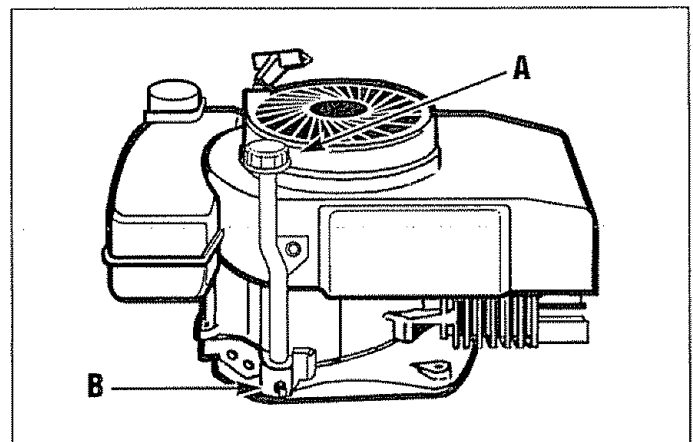
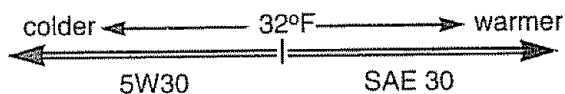

Figure 27: Dipstick (A) and oil drain plug (B).

# CUSTOMER RESPONSIBILITIES

## To Change the Oil

1. Change the oil while engine is still warm from recent operation. **Stop engine and make sure that all moving parts have come to a complete stop. Disconnect spark plug wire and secure it away from spark plug.**
2. The oil drain plug (B in Figure 27 on Page 27) is located at the bottom of the dipstick tube.
3. Prop up the wheels on the opposite side of the machine so that the oil drain plug is at the lowest point on the engine.
4. To prevent oil from spilling on the machine, make a V-shaped drain trough out of aluminum foil or stiff cardboard and place the trough beneath the drain plug.
5. Remove the dipstick (A, Figure 27) to vent the crankcase and speed up draining time.
6. Remove the oil drain plug (B, Figure 27). After the oil has drained, install the oil drain plug and tighten securely.
7. Refill the engine crankcase with recommended oil described below. After adding oil, securely replace the dipstick (A) and clean up any spilled oil.



## SERVICE THE AIR FILTER

The engine is equipped with a paper element air filter. See Figure 28.

### IMPORTANT:

- NEVER RUN ENGINE WITHOUT COMPLETE AIR FILTER ASSEMBLY INSTALLED.
- REPLACE FILTER ONCE A YEAR, OR MORE OFTEN IF USED IN EXTREMELY DUSTY OR DIRTY CONDITIONS.
- DO NOT ATTEMPT TO CLEAN OR OIL FILTER.
- REPLACEMENT FILTERS ARE AVAILABLE FROM ANY SEARS ROEBUCK AND CO. (OR SEARS CANADA, INC.) SERVICE CENTER.

### To Replace Air Filter

1. **Stop engine and make sure that all moving parts have come to a complete stop. Disconnect spark plug wire and secure it away from spark plug.**
2. Turn cover to the left (counterclockwise) and remove cover and filter from flange. Discard filter. See Figure 28.
3. Clean cover and flange thoroughly.
4. Position cover and filter against flange with tab on cover inserted into lower left corner of slot in flange.
5. Push cover firmly against flange and turn it to the right (clockwise) as far as it will go. Be sure retainers are locked around flange.

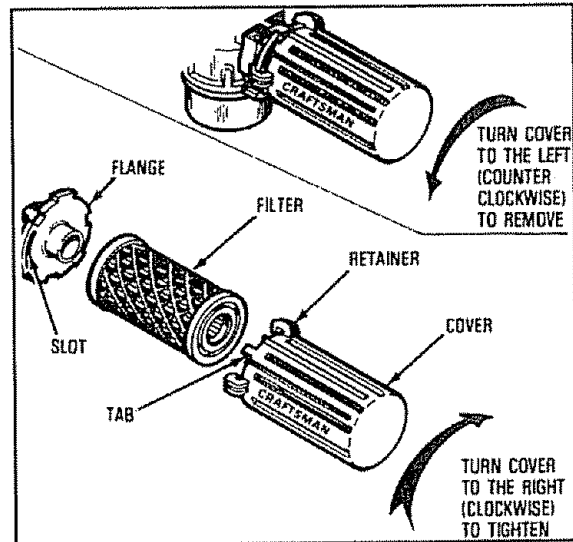

Figure 28: Air cleaner assembly.

## CLEAN COOLING SYSTEM

To ensure adequate cooling of the engine, air must circulate freely through the air intake screen (A in Figure 29) and over the cooling fins (B).

After every 5 operating hours, clean the air intake screen and the cooling fins to remove any chaff, dirt and debris.

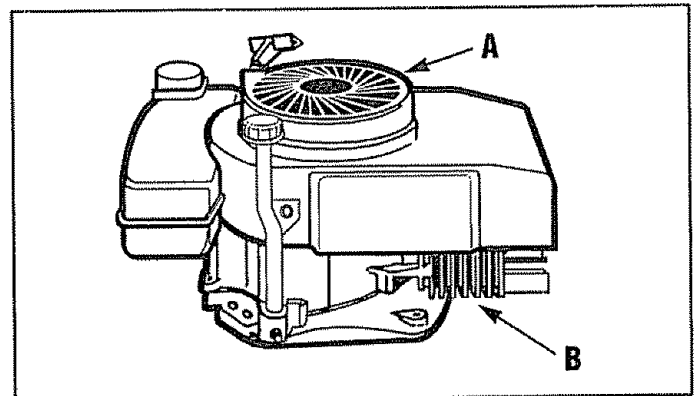

Figure 29: Air intake screen and cooling fins.

## INSPECT THE ENGINE SPARK ARRESTER (IF SO EQUIPPED)

If the muffler on the engine is equipped with a spark arrester screen assembly, remove the assembly every 50 hours of operation for cleaning and inspection. Replace a damaged assembly.

## SERVICE THE SPARK PLUG

Check the spark plug yearly or every 100 operating hours. Replace the spark plug if the electrodes (Figure 30 on Page 29) are pitted or burned, or if the porcelain is cracked. Use a Champion J-19LM, Autolite 458, or equivalent. In Canada, replace with a resistor spark plug.

# CUSTOMER RESPONSIBILITIES

## Check The Spark Plug

1. **Stop the engine and make sure that all moving parts have come to a complete stop. Disconnect the spark plug wire and secure it away from the spark plug.**
2. Clean the area around the spark plug to prevent debris from falling into the spark plug hole.
3. Remove and inspect the spark plug. Check the electrode gap with a wire feeler gauge and set the gap at .030", if necessary.
4. Install spark plug and tighten securely.

## CARBURETOR AND IGNITION SYSTEM INFORMATION

- The factory-adjusted carburetor settings should be satisfactory for most conditions. If you feel that an adjustment is needed, contact your local Sears Service Center or retail store.
- The engine is equipped with an electronic ignition system without points and a condenser. Only spark plug maintenance is required. If the ignition system is not functioning properly, contact your local Sears Service Center or retail store.



### CAUTION

Do not tamper with the engine governor which is factory set for proper engine speed. Overspeeding the engine above the factory high speed setting can be dangerous and will void the engine warranty.

Request authorized service if the problem persists.

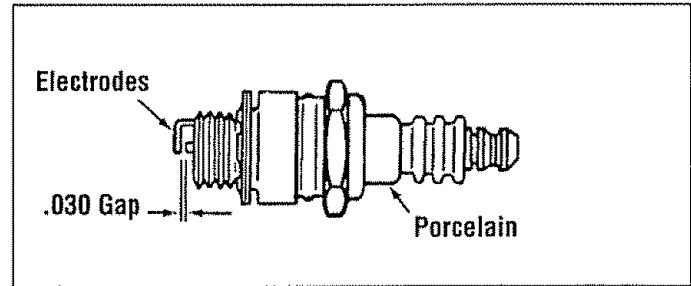

Figure 30: Spark plug.

## CHECK BOLTS AND NUTS FOR TIGHTNESS

Be sure that the bolts and nuts on your machine are always securely tightened. **With the engine shut off and the spark plug wire disconnected**, check the bolts and nuts before each use of the machine. Refer to the Parts List at the back of this Manual for replacement hardware. Do not overtighten bolts. See the Torque Specifications Chart on Page 31.

## LUBRICATION

With the exception of the engine, the machine is lifetime lubricated. Do not oil or grease any part of the machine.

# SERVICE AND ADJUSTMENTS

## REPLACE THE CHIPPER CUTTING BLADE

Over time, the chipper cutting blade edge (A in Figure 33 on Page 31) will dull. Sharpen or replace the blade when the chipper no longer cuts efficiently.

- ❑ Discard a cracked or severely nicked blade because the blade could break apart and cause personal injury.
- ❑ We recommend that you take the blade to a **professional sharpening service** for expert sharpening. All grinding must be flat and uniform along the beveled edge of the blade to maintain the original 45° cutting angle. Sharpen a blade that is dull or that has only minor nicks. The blade is made from tempered steel and is extremely hard – do not attempt to sharpen with a hand file.

**IMPORTANT:** Do not reuse the blade mounting screws and locknuts. New screws and locknuts are supplied with a new blade. **Use only factory-supplied hardware. Do not use substitutes or failure of the equipment or personal injury could result.** See the Parts List at the back of this Manual to order individual replacement screws and locknuts if re-installing the old blade.

### To Remove and Replace the Blade

1. **Stop the engine and make sure that all moving parts have come to a complete stop. Disconnect the spark wire and secure it away from the spark plug.**
2. Remove the collection bag or the blower deflector.
3. The blade removal procedure requires removal of the engine. To avoid a potential safety hazard from spilled gasoline, the fuel tank must be emptied of all gasoline before the engine is removed. Follow Steps "a" through "d" to empty the fuel tank.
  - a. Place a clean pan below the fuel tank to catch the gasoline as it drains. Remove gas cap from fuel tank.



### DANGER

Gasoline and its vapors are highly flammable and explosive.

To avoid serious personal injury, be sure area is well ventilated and keep gasoline away from open flame or sparks. Observe no smoking rules at all times. Use an approved fuel container.

- b. Using adjustable pliers, squeeze the tabs on the hose clamp (A in Figure 31) that secures the fuel line (B) to the fuel tank fitting. Slide the clamp a few inches down the fuel line.
- c. Pinch the fuel line with your fingers to prevent gasoline from leaking and then gently pull the fuel line off the fuel tank fitting. Drain the gasoline into the pan and then transfer the gasoline to a container designed for fuel storage.

- d. Re-install the fuel line on the fuel tank fitting and secure it in place with the hose clamp. Install gas cap on fuel tank.

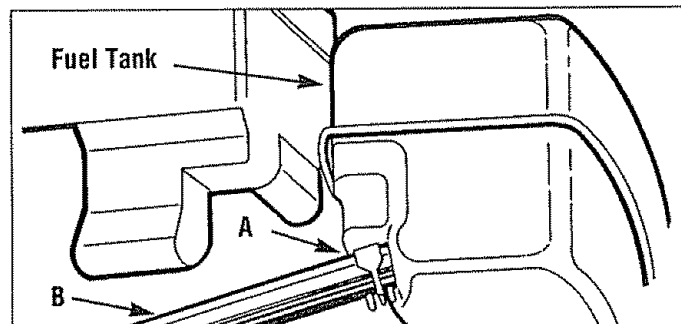

Figure 31: Hose clamp and fuel line.

4. With a 3/8" wrench, remove the three bolts that secure the engine mounting base to the deck. One bolt is shown in Figure 32. A second bolt is located at the rear of the machine above the left side of the blower opening. This second bolt also secures the short wire leading to the safety interlock. Remove the wire and the lockwasher along with this bolt. Also, disconnect the long safety interlock wire where it attaches to the engine above the engine muffler. A third bolt is located near the right front wheel.
5. Remove the two hair pin clips on the right side and rear of the housing which secure the shredder screen rods, and then remove the rods and shredder screen.
6. Slide the engine forward (in direction of the spark plug) and carefully lift engine out of chassis. Gently place the engine on a clean floor or workbench with the spark plug side facing up.



### WARNING

To avoid personal injury, handle chipper cutting blade with extreme care. The cutting edge is very sharp.

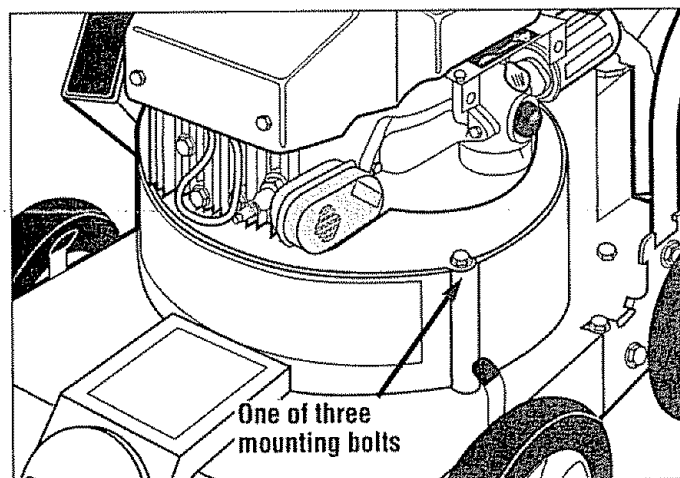

Figure 32: Engine mounting bolts.

# SERVICE AND ADJUSTMENTS

7. The chipper cutting blade (A in Figure 33) is mounted on the upper side of the flywheel assembly (B). AVOID CONTACT WITH THE BLADE AS IT IS EXTREMELY SHARP! To remove the blade, first remove the flywheel assembly as described below:

a. Rotate the flywheel assembly until the cutout (C) in the flywheel assembly is located below the chipper chute. To prevent the flywheel assembly from turning, place a 1/2" or thicker wood dowel down the chipper chute through the cutout. See Figure 33.

b. Using a box end 9/16" wrench, remove the bolt (D) and concave washer (E). Carefully slide the assembly off the crankshaft. Do not lose the key (F), or any shims (G). NOTE: Shims (if used) may be inside bore of flywheel assembly. See Figure 33.

8. With a 3/16" hex key (Allen) wrench and 1/2" box wrench, remove the two locknuts (I) and screws (H) that secure the blade to flywheel assembly. If necessary, first clean out the socket holes in the screw heads with a sharp nail or awl. See Figure 33.

9. Before installing a new or resharpened blade, thoroughly clean the area where the blade seats on the flywheel assembly (also clean the old blade, if it is being reused).

10. Position the blade on the upper side of the flywheel assembly, with the sharp edge of the blade on top. Install two **new** screws down through the blade and add **new** locknuts. **Use only factory-supplied hardware. Do not use substitutes or equipment failure or personal injury could result.** Tighten securely (torque to 240 lbs-in or 20 lbs-ft).

11. Place key (F) in the engine crankshaft and re-install any shims (G). Align the keyway in the bore with the key on the crankshaft and slide the flywheel assembly into place.

12. Place the concave washer (E [dished-in side of washer faces flywheel assembly]) on the mounting bolt (D) and install the bolt in the crankshaft. Tighten securely (torque to 204 lbs-in). Remove the wood dowel from the chipper chute.

13. Replace the engine in the chassis, with the spark plug side facing the front (toward Inlet Cap).

14. Install the short safety interlock wire terminal and the lockwasher on one of the mounting bolts and install it at the rear of the machine above the left side of the blower opening. Connect the long interlock wire to the terminal above the muffler. Replace the other two mounting bolts and tighten all three bolts to 60-65 lbs-in. **DO NOT OVERTIGHTEN BOLTS OR DAMAGE COULD RESULT TO HOUSING**

15. Install shredder screen in housing, insert screen rods, and secure with hair pin clips.

16. Replace the collection bag or blower deflector and reposition the handlebars in the correct operating position for vacuuming or blower operation.

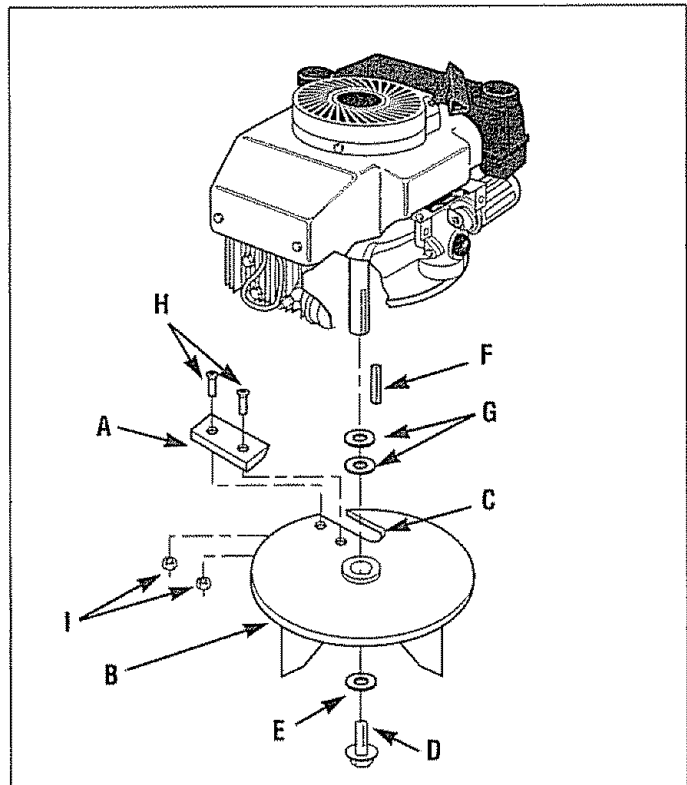

Figure 33: Chipper cutting blade removal/replacement.

## TORQUE SPECIFICATIONS

Bolt Size	Torque (lbs-in)	Location of Bolt(s)
5/16"-14	60-65 lbs-in	1. Engine mounting plate to housing
	40-55 lbs-in	2. Handle pivot bracket.
	40-55 lbs-in	3. Upper housing to lower housing
5/16"-24	240 lbs-in	1. Chipper knife to fan assembly.
3/8"-16	180 lbs-in	1. Wheel bolts
		2. Handlebars to pivot brackets.
3/8"-16	276 lbs-in	1. Engine mounting plate to engine
3/8"-24	204 lbs-in	1. Fan assembly to engine

# STORAGE

## OFF-SEASON STORAGE



### DANGER

To Prevent Personal Injury or Property Damage:

- Never perform maintenance while engine is running or when spark plug wire is connected to spark plug, except where specifically instructed to do so.
- Never store machine with fuel in the fuel tank inside a building where fumes may reach an open flame or spark, or where ignition sources are present such as hot water and space heaters, furnaces, clothes dryers, stoves, electric motors, etc.

NOTE: A yearly check-up by your local Sears Service Center is a good way to ensure that your machine will provide maximum performance for the next season.

1. Review the "Customer Responsibilities and Storage" safety rules in the Safety Section of this Manual.

2. To prevent engine damage (if the machine is not used for more than 30 days) follow the steps below:

- a. It is important to prevent gum deposits from forming in essential fuel system parts such as the carburetor, fuel filter, fuel hose or tank during storage. Also, experience indicates that alcohol blended fuels (called gasohol or using ethanol or methanol) can attract moisture which leads to separation and formation of acids during storage. Acidic gas can damage the fuel system of an engine while in storage.
- b. To remove gasoline, run the engine until the tank is empty and the engine stops.
- c. If you do not want to remove gasoline, a fuel stabilizer (such as Craftsman Fuel Stabilizer No. 335500) may be added to any gasoline left in the tank to minimize gum deposits and acids. If the tank is almost empty, mix the stabilizer with fresh gasoline in a separate container and add some to the tank. ALWAYS FOLLOW INSTRUCTIONS ON THE STABILIZER CONTAINER. THEN, RUN THE ENGINE AT LEAST 10 MINUTES AFTER THE STABILIZER IS ADDED TO ALLOW MIXTURE TO REACH CARBURETOR. STORE THE MACHINE IN A SAFE PLACE. SEE DANGER ABOVE.

- d. Change the oil if it has not been changed in the last three months. See Page 28.
  - e. Lubricate the piston/cylinder area. First, remove the spark plug. Then, squirt approximately 1/2 ounce of clean engine oil into the spark plug hole. Cover the spark plug hole with a rag to absorb oil spray and then rotate the engine by pulling the starter rope two or three times. Finally, re-install the spark plug.
  - f. Clean the engine by removing any dirt, chaff or other debris from its exterior.
3. Thoroughly clean the machine, collection bag, hose, and blower deflector.
  4. Check that all hardware is in place and securely fastened. Refer to the Parts List in this Manual for replacement hardware.
  5. Inspect all visible moving parts for damage, breakage, and wear. Repair or replace as needed (refer to Parts List).
  6. Touch up paint on all chipped or scratched surfaces to prevent rust from forming.
  7. If possible, store machine indoors (see DANGER statement on this page). Cover machine for protection from dust and dirt. Use a covering (not plastic) that does not retain moisture. Be sure the engine and muffler are cool before covering the machine.

# TROUBLESHOOTING POINTS

Before performing any of the corrections in this Troubleshooting Chart, refer to the appropriate information contained in this Manual for the correct safety precautions and operating or maintenance procedures.

PROBLEM	POSSIBLE CAUSE	CORRECTION
Engine Does Not Start	<ol style="list-style-type: none"> <li>1. Spark plug wire disconnected</li> <li>2. Engine Control Lever in OFF position.</li> <li>3. Fuel tank empty.</li> <li>4. Stale gasoline.</li> <li>5. Safety Interlock switch has failed</li> <li>6. Collection bag or blower deflector not installed</li> <li>7. Incorrect Control Lever setting.</li> <li>8. Dirty air filter</li> <li>9. Defective or incorrectly gapped spark plug</li> <li>10. Carburetor out of adjustment</li> </ol>	<ol style="list-style-type: none"> <li>1. Reconnect wire</li> <li>2. Put Engine Control Lever in START (Page 20)</li> <li>3. Add gasoline (Page 19)</li> <li>4. Drain gasoline and add fresh gasoline</li> <li>5. Contact Sears Service Center</li> <li>6. Install collection bag or blower deflector</li> <li>7. Put Control Lever in START (Page 20)</li> <li>8. Replace filter (Page 28)</li> <li>9. Inspect spark plug (Page 28)</li> <li>10. Contact Sears Service Center</li> </ol>
Engine Runs Poorly	<ol style="list-style-type: none"> <li>1. Bad spark plug</li> <li>2. Incorrect Engine Control Lever setting.</li> <li>3. Dirty air filter</li> <li>4. Carburetor out of adjustment.</li> <li>5. Stale gasoline.</li> <li>6. Dirt or water in fuel tank.</li> <li>7. Engine cooling system clogged.</li> </ol>	<ol style="list-style-type: none"> <li>1. Replace spark plug (Page 29)</li> <li>2. Put Lever in correct setting (Page 20)</li> <li>3. Replace filter (Page 28)</li> <li>4. Contact Sears Service Center.</li> <li>5. Drain gasoline and add fresh gasoline.</li> <li>6. Contact Sears Service Center</li> <li>7. Clean air intake screen and cooling fins (Page 28)</li> </ol>
Engine Overheats	<ol style="list-style-type: none"> <li>1. Engine cooling system clogged.</li> <li>2. Carburetor out of adjustment.</li> <li>3. Oil level is low</li> </ol>	<ol style="list-style-type: none"> <li>1. Clean air intake screen and cooling fins (Page 28)</li> <li>2. Contact Sears Service Center</li> <li>3. Check and add oil (Page 27)</li> </ol>
Chipper Does Not Chip	<ol style="list-style-type: none"> <li>1. Solid object jammed in unit.</li> <li>2. Broken or missing chipper blade</li> </ol>	<ol style="list-style-type: none"> <li>1. Check for and remove any obstruction (Page 26)</li> <li>2. Replace blade (Page 30)</li> </ol>
Chipping Performance Is Poor.	<ol style="list-style-type: none"> <li>1. Dull chipper blade</li> <li>2. Engine not reaching full RPM</li> <li>3. Excessively worn engine shaft bearing(s)</li> <li>4. Loose engine mounting bolts</li> <li>5. Chipper blade to anvil clearance incorrect</li> </ol>	<ol style="list-style-type: none"> <li>1. Sharpen or replace blade (Page 30)</li> <li>2. Contact Sears Service Center</li> <li>3. Contact Sears Service Center.</li> <li>4. Tighten bolts (Page 29)</li> <li>5. Contact Sears Service Center (correct clearance is .030" – .090")</li> </ol>



# TROUBLESHOOTING POINTS

PROBLEM	POSSIBLE CAUSE	CORRECTION
Loss of Vacuum.	<ol style="list-style-type: none"> <li>1. Vacuum inlet or vacuum hose clogged.</li> <li>2. Collection bag full.</li> <li>3. Discharge opening clogged</li> <li>4. Processing chamber clogged</li> <li>5. Engine not reaching full RPM</li> </ol>	<ol style="list-style-type: none"> <li>1. Check for and remove any obstruction (Page 26).</li> <li>2. Remove and empty bag (Page 12)</li> <li>3. Remove collection bag to clean opening (Page 12)</li> <li>4. Check for and remove any obstruction (Page 26).</li> <li>5. See "Engine Runs Poorly" at beginning of chart.</li> </ol>
Unusual Vibration or Noise	<ol style="list-style-type: none"> <li>1. Solid object jammed in unit.</li> <li>2. Chipper blade loose or damaged.</li> <li>3. Rotor assembly out of balance.</li> <li>4. Chipper blade to anvil clearance incorrect.</li> <li>5. Engine cylinder shaft or crankshaft is bent or damaged.</li> <li>6. Loose engine mounting bolts</li> <li>7. Loose or missing bolts on unit.</li> <li>8. Engine shaft bearings damaged.</li> </ol>	<ol style="list-style-type: none"> <li>1. Check for and remove any obstruction. See Page 26.</li> <li>2. Tighten or replace (Page 30)</li> <li>3. Contact Sears Service Center</li> <li>4. Contact Sears Service Center (correct clearance is .030" – .090")</li> <li>5. Contact Sears Service Center</li> <li>6. Tighten bolts (Page 29)</li> <li>7. Tighten or replace bolts (Page 29)</li> <li>8. Contact Sears Service Center.</li> </ol>



# DECALS

**⚠ DANGER**



**ROTATING CUTTING BLADES AND THROWN OBJECTS WILL CAUSE SERIOUS INJURY!**

- KEEP CLEAR OF DISCHARGE OPENING AT ALL TIMES.
- DO NOT OPERATE WITHOUT COLLECTION BAG OR BLOWER DEFLECTOR INSTALLED.
- DO NOT OPERATE IF SAFETY INTERLOCK IS BROKEN OR BECOMES DEFECTIVE. SEE OWNER/OPERATOR MANUAL.

**IMPORTANT**

- READ OWNER/OPERATOR MANUAL BEFORE STARTING AND USING THIS MACHINE. FOR A REPLACEMENT MANUAL OR DECALS, CONTACT YOUR LOCAL SEARS SERVICE CENTER OR SEARS RETAIL STORE.
- WEAR APPROVED SAFETY GLASSES AND GLOVES. DO NOT WEAR LOOSE-FITTING CLOTHING.
- KEEP BYSTANDERS, CHILDREN AND PETS AWAY FROM OPERATING AREA.
- IF MACHINE JAMS OR BECOMES CLOGGED, STOP ENGINE, DISCONNECT SPARK PLUG WIRE, AND WAIT FOR ALL MOVING PARTS TO STOP BEFORE SERVICING.



**⚠ DANGER**

**ROTATING CUTTING BLADES WILL CAUSE SERIOUS INJURY!**

**INLET CAP OR HOSE MUST BE INSTALLED.**



**IMPORTANT: CORRECTLY POSITION HANDLEBARS BEFORE STARTING.**

<p><b>BLOWER POSITION</b> (INCLUDES DEFLECTOR)</p> 	<p><b>VACUUM POSITION</b> (INCLUDES BAG)</p> 
--	--

**⚠ DANGER**

**MATERIALS EXIT FROM BLOWER AT HIGH SPEEDS**

**KEEP HANDS, FEET AND FACE AWAY FROM BLOWER DISCHARGE OPENING TO AVOID SERIOUS INJURY.**

**⚠ WARNING**

**HOT SURFACES CAN CAUSE SEVERE BURNS**

**DO NOT TOUCH MUFFLER OR ADJACENT AREAS.**

**To rotate**



**Push in here**

1769123

**VACUUM**

**BLOWER**

**BLOWER**

**VACUUM**

**⚠ DANGER**

**ROTATING CUTTING BLADE WILL CAUSE SERIOUS INJURY!**

**KEEP HANDS OUT OF CHIPPER CHUTE INLET AT ALL TIMES.**





REF No.	PART No.	DESCRIPTION	QTY.
1	143.955002*	Engine, 5 HP	1
2	1762042	Thread-Forming Screw 3/8-16 x 1"	3
4	1763390	Flange Screw, 5/16-13 x 1"	13
5	1763255	Fan and Chipper Disc Assy	1
6	1104338	Key, 1/4 x 1/4 x 2"	1
7	1100010	Capscrew, 3/8-24 x 1-1/4"	1
8	1756993	Conical Washer	1
9	1185831	Washer	4
11	1763261	Inlet Housing	1
12	1763262001	Divider Plate	1
13	1763265	Wheel and Tire Assy	4
15	1763367	Shoulder Screw	2
16	1763356	Flat Washer	2
19	1763391	Rear Axle	1
20	1100350	Cotter Pin, 1/8 x 1"	2
21	1890234	Flat Washer, 1/2"	6
22	1763268001	Upper Handle	1
23	1768668001	Lower Handle	1
24	1763767	Knob	2
25	1731025	Curved Head Bolt	2
26	1107382	Flat Washer, 5/16"	2
27	1768670001	Wheel and Handle Pivot (left side only)	1
28	1763331	Shoulder Screw, 3/8-16 (left side only)	1
30	1769062	Elbow	1
33	1767422	Ignition Ground Switch	1
35	1764197	Switch Tab	2
38	1805368	Flat Washer, 9/64 x 5/16	4
39	1747138	Pop Rivet, 1/8 x 3/8	4
40	1764179	Chipper Tube Flap	1
41	1763257	Operating Instructions Decal	1
42	1764189	Cable Tie	1
43	1764439	Pop Rivet, 1/8 x 3/5	2
44	1768720	Logo Decal	1
45	1763288	Danger Decal	1
46	1763289	Warning Decal	1
47	1763290	Danger Decal	1
49	1768722	Bag Decal	1
50	1763294	Danger Decal	1
51	1768724	Handlebar Decal	1
53	1900333	Made in U.S.A. Decal	1

REF No.	PART No.	DESCRIPTION	QTY.
54	1756954	Goggles	1
57	1763263	Hose Cap Inlet	1
59	1761627	Height Adjusting Lever	2
60	1763393	Wheel Height Adjusting Quadrant	2
61	1763392	Wheel Mounting Arm	2
62	1186259	Jam Nut, 3/8-16	2
63	1737499	Grip	2
64	1100047	Hex Screw, 3/8-16 x 1-1/2"	4
65	1893445	Flat Washer	6
66	1107383	Flat Washer, 3/8"	2
67	1733398	Toplock Nut, 3/8-16	4
79	1764076	Screen Rod	2
80	1756986	Hair Pin	2
83	1764649	Bracket	1
86	1186309	Flange Screw, 1/4-20 x 5/8"	2
87	1734398	Toplock Nut, 1/4-20	3
88	1728401	Loctite 242	N/I
89	1765507	Pop Rivet, 1/8 x 1/2	2
96	1769136001	Handle Support (right side only)	1
97	1768703	Shoulder Screw (right side only)	1
98	1768655	Retaining Knob	1
99	1185748	Wave Washer	1
100	1769123	Handle Adjustment Decal	1
101	1115958	Machine Screw, Round Head, 1/4-20 x 1-1/2"	1
200	1769635	Collection Bag Kit, (includes Ref. No's. 30, 35, 38, 39 & 42)	1
201	1769649	Blade Kit (includes Ref. No's. 202, 203 & 204— see below)	1
205	1769633	Upper Housing Kit (includes Ref. No's. 33, 41, 43, 44, 50, 51, 53, 57, 83, 87, 98, 99, & 101)	1
206	1769654	Engine Mounting Plate Kit (Includes Engine Plate Assembly, and Ref. No's. 40, 45 & 89)	1
207	1769637	Deflector Kit (includes Discharge Deflec- tor, and Ref. No's. 35, 38, 39 & 47)	1
208	1767298	Shredder Screen Kit	1
209	1902079	Spray Paint Can, Black, 13 oz	N/I
✓	1902963	Chipper/Vac Owner's Manual	1

N/I Part not included with unit. Order separately.

\* Order parts from your local Sears Service Center. Refer to engine for model and type number.

**BLADE KIT NO. 1769649**

REF No.	PART No.	DESCRIPTION	QTY.
202	1763742	Toplock Nut, 5/16-24	2
203	1763741	Flange Screw, 5/16-24	2
204	**	Chipper Knife	1

\*\* Not sold separately

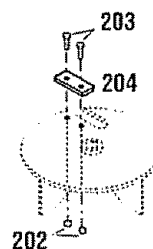

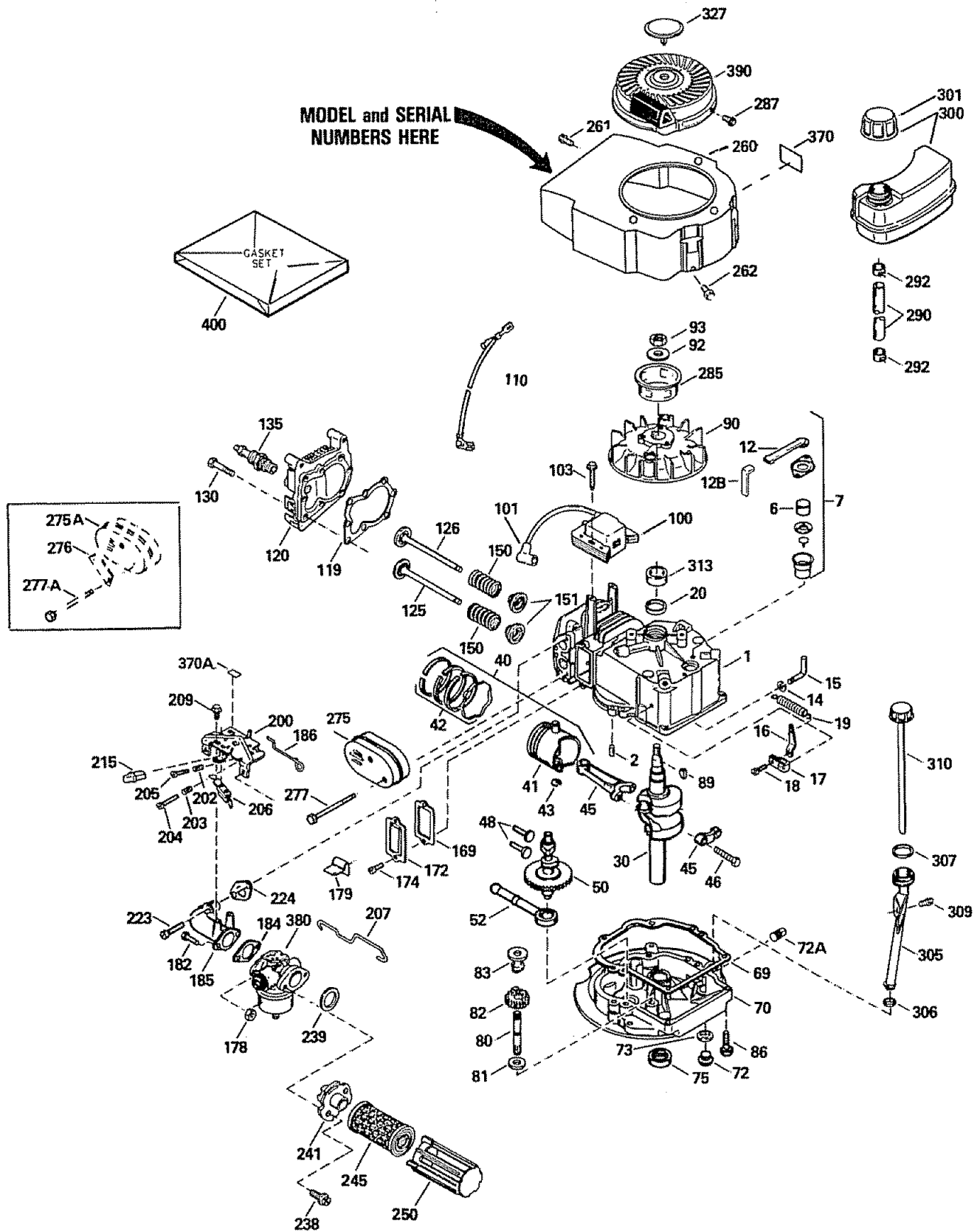

Ref. #	Part #	Part Name	Ref. #	Part #	Part Name
1	36478A	Cylinder (Incl. 2, 7, 20 & 125)	150	35991	Valve Spring
2	26727	Dowel Pin	151	31673	Valve Spring Cap
6	33734	Breather Element	169	27234A	Valve Cover Gasket
7	36557	Breather Body Ass'y. (Incl. 6 & 12)	172	32755	Valve Cover
12	36558	Breather Cover & Tube (Incl. 12B)	174	30200	Screw, 10-24 x 9/16"
12B	34695	Breather Tube Elbow	178	29752	Nut & Lock Washer, 1/4-28
14	28277	Washer	179	30593	Retainer Clip
15	30589	Governor Rod (Incl. 14)	182	6201	Screw, 1/4-28 x 7/8"
16	31383A	Governor Lever	184	26756	Carburetor To Intake Pipe Gasket
17	31335	Governor Lever Clamp	185	31384A	Intake Pipe (Incl. 224)
18	650548	Screw, 8-32 x 5/16"	186	34337	Governor Link
19	36281	Extension Spring	200	35727	Control Bracket (Incl. 202 thru 206)
20	32600	Oil Seal	202	36482	Compression Spring
30	36231	Crankshaft	203	31342	Compression Spring
40	36073	Piston, Pin & Ring Set (Std.)	204	650549	Screw, 5-40 x 7/16"
40	36074	Piston, Pin & Ring Set (.010" OS)	205	650777	Screw, 6-32 x 21/32"
40	36075	Piston, Pin & Ring Set (.020" OS)	206	610973	Terminal
41	36070	Piston & Pin Ass'y. (Std.) (Incl. 43)	207	34336	Throttle Link
41	36071	Piston & Pin Ass'y. (.010" OS) (Incl. 43)	209	30200	Screw, 10-24 x 9/16"
41	36072	Piston & Pin Ass'y. (.020" OS) (Incl. 43)	215	32410	Control Knob
42	36076	Ring Set (Std.)	223	650451	Screw, 1/4-20 x 1"
42	36077	Ring Set (.010" OS)	224	34690A	Intake Pipe Gasket
42	36078	Ring Set (.020" OS)	238	650932	Screw, 10-32 x 49/64"
43	20381	Piston Pin Retaining Ring	239	34338	Air Cleaner Gasket
45	30963B	Connecting Rod Ass'y. (Incl. 46)	241	35797	Air Cleaner Collar
46	32610A	Connecting Rod Bolt	245	35066	Air Cleaner Filter
48	27241	Valve Lifter	250	35065	Air Cleaner Cover
50	35992	Camshaft (MCR)	260	36420A	Blower Housing
52	29914	Oil Pump Ass'y.	261	30200	Screw, 10-24 x 9/16"
69	35261	Mounting Flange Gasket	262	650831	Screw, 1/4-20 x 1/2"
70	36249A	Mounting Flange (Incl. 72 thru 83)	275	36456A	Muffler (Incl. 277)
72	30572	Oil Drain Plug	275A	36424	Spark Arrestor Muffler (Optional)
72A	28534	Oil Drain Plug	276	33753	Locking Plate (Optional)
73	28833	Drain Plug Gasket	277	650988	Screw, 1/4-20 x 2-5/16"
75	27897	Oil Seal	277A	650795	Screw, 1/4-20 x 2-1/4" (Optional)
80	30574A	Governor Shaft	285	35000A	Starter Cup
81	30590A	Washer	287	650926	Screw, 8-32 x 21/64"
82	30591	Governor Gear Ass'y. (Incl. 81)	290	34357	Fuel Line
83	30588A	Governor Spool	292	26460	Fuel Line Clamp
86	650488	Screw, 1/4-20 x 1-1/4"	300	35586	Fuel Tank (Incl. 292 & 301)
89	611004	Flywheel Key	301	35355	Fuel Cap
90	611112	Flywheel	305	35647	Oil Fill Tube
92	650815	Belleville Washer	306	34265	"O"-Ring
93	650816	Flywheel Nut	307	35499	"O"-Ring
100	34443A	Solid State Ignition	309	650562	Screw, 10/32 x 1/2"
101	610118	Spark Plug Cover	310	35648	Dipstick
103	650814	Screw, Torx T-15, 10-24 x 1"	313	34080	Spacer
110	36230	Ground Wire	327	35392	Starter Plug
119	36477	Cylinder Head Gasket	370	35169	Control Decal
120	36476	Cylinder Head	370A	36261	Lubrication Decal
125	36471	Exhaust Valve (Std.) (Incl. 151)	380	632670	Carburetor (Incl. 184)
125	36472	Exhaust Valve (1/32" OS) (Incl. 151)	390	590732	Rewind Starter
126	29314B	Intake Valve (Std.) (Incl. 151)	400	36481*	Gasket Set (Incl. items marked PK in notes)
126	29315C	Intake Valve (1/32" OS) (Incl. 151)			
130	6021A	Screw, 5/16-18 x 1-1/2"			
135	35395	Resistor Spark Plug (RJ19LM)			



**CARBURETOR NO. 632670 (Fig. 1)**

Ref. No.	Part No.	Part Name
1	631615	Throttle Shaft & Lever Assembly
2	631767	Throttle Return Spring
4	631184	Dust Seal Washer
5	631183	Dust Seal (Throttle)
6	632504	Throttle Shutter
7	650506	Shutter Screw
16	631775	Fuel Fitting
25	631867	Float Bowl
27	631024	Float Shaft
28	632019	Float
29	631028	Float Bowl "O" Ring
30	631021	Inlet Needle, Seat & Clip (Incl. 31)
31	631022	Spring Clip
35	632694	Primer Bulb/Retainer Ring
35A	632647	Primer Bulb Filter
40	632503	High Speed Bowl Nut
44	27110	Bowl Nut Washer
48	631027	Welch Plug, Atmospheric Vent

**REWIND STARTER NO. 590732 (Fig. 2)**

Ref. No.	Part No.	Part Name
1	590599A	Spring Pin (Incl. 4)
2	590600	Washer
3	590696	Retainer
4	590601	Washer
5	590697	Brake Spring
6	590698	Starter Dog
7	590699	Dog Spring
8	590618A	Pulley & Rewind Spring Assy.
11	590695	Starter Housing Assy. (40 degrees grommet)
12	590535	Starter Rope (Length 98" x 9/64" dia.)
13	590701	Starter Handle

**HOSE KIT NO. 987.856790 (Fig. 3)**

Ref. No.	Part No.	Part Name
1	1767377	Hose
2	1765866	Tube
3	1763291	Hose Adapter
4	1763281001	Handle
5	1756875	Handle Grip
6	1763283001	Inlet Cover
7	1740083	Worm Clamp
8	1100123	Slotted Head Screw, 1/4-20 x 1-1/4"
9	1186389	Flange Whiz Locknut, 1/4-20
10	1107381	Washer

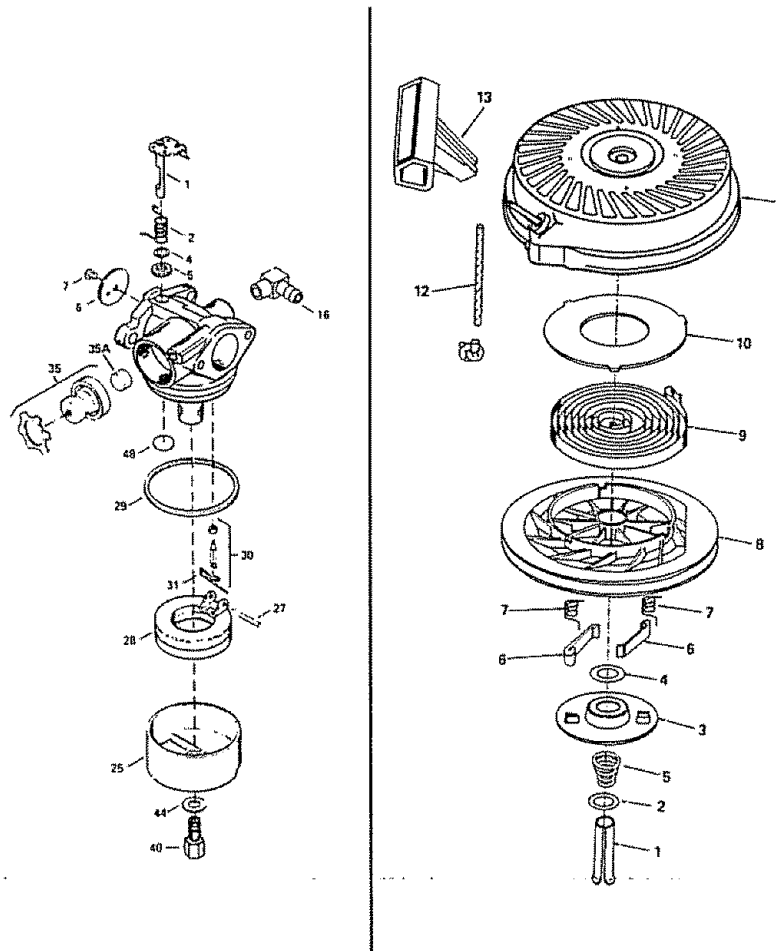

Figure 1

Figure 2

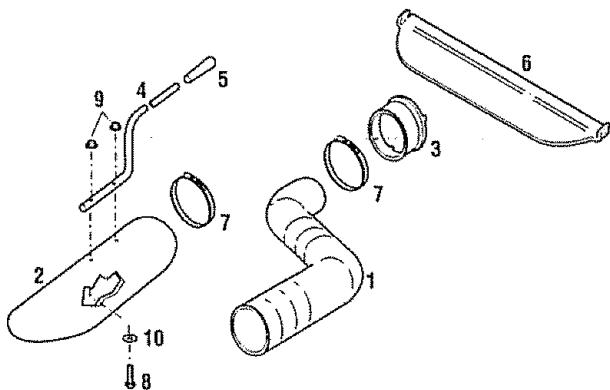

Figure 3



# NOTES



# NOTES

# NOTES

# SEARS

## OWNER'S MANUAL

**MODEL NO.  
987.799601**

**IF YOU NEED  
REPAIR SERVICE  
OR PARTS:**

FOR REPAIR SERVICE  
CALL THIS TOLL FREE  
NUMBER:

**1-800-4-REPAIR**  
(1-800-473-7247)

FOR REPLACEMENT  
PARTS INFORMATION AND  
ORDERING, CALL THIS  
TOLL FREE NUMBER:

**1-800-FON-PART**  
(1-800-366-7278)

# CRAFTSMAN®

## 5 Horsepower CHIPPER/VAC with Wheel Adjusters

Each Chipper/Vac has its own model number. Each engine has its own model number.

The model number for your machine will be found on the left side of the unit.

The model number for the engine will be found on the engine's blower housing above the spark plug.

All parts listed herein may be ordered through Sears, Roebuck and Co. Service Centers and most Retail Stores.

WHEN ORDERING REPAIR PARTS, ALWAYS GIVE THE FOLLOWING INFORMATION:

- PRODUCT - "CHIPPER/VAC"
- MODEL NUMBER - 987.799601
- ENGINE MODEL NUMBER - 143.955002
- PART NUMBER
- PART DESCRIPTION

Your Sears merchandise has added value when you consider that Sears has service units nationwide staffed with Sears trained technicians...professional technicians specifically trained on Sears products, having the parts, tools, and the equipment to insure that we meet our pledge to you, we service what we sell.

**Sears, Roebuck and Co., Hoffman Estates, IL 60179 U.S.A.**