

LIVE WITH
ILVE
IDEAS



INSTRUCTION MANUAL GAS COOKTOPS

IL**604, IL**775, IL**905 (** = BV, WV and SS models)



OPEN 24/7
ILVE ACCESSORIES ONLINE SHOP

For a wide range of coffee machines, pods, and other ILVE accessories at the click of a button shop.ilve.com.au

Dear customer,

We thank you and congratulate you on your choice.

This new carefully designed product, manufactured with the highest quality materials, has been carefully tested to satisfy all your cooking demands.

We would therefore request you to read and follow these easy instructions which will allow you to obtain excellent results right from the start.

May we wish you all the very best with your modern appliance!

For service and spare parts, please call the relevant number listed on the back page of this manual.

THE MANUFACTURER**Index****Instructions for use**

Installation,
Use,
Maintenance,

Instructions for the installer

Installation,
Gas connection,
Electrical connection,
User characteristics,

THIS APPLIANCE IS CONCEIVED FOR DOMESTIC USE ONLY.

THE MANUFACTURER SHALL NOT IN ANY WAY BE HELD RESPONSIBLE FOR WHATEVER INJURIES OR DAMAGES ARE CAUSED BY INCORRECT INSTALLATION OR BY UNSUITABLE, WRONG OR ABSURD USE. THIS APPLIANCE IS NOT INTENDED FOR USE BY PERSONS (INCLUDING CHILDREN) WITH REDUCED PHYSICAL, SENSORY OR MENTAL CAPABILITIES, OR LACK OF

EXPERIENCE AND KNOWLEDGE, UNLESS THEY HAVE BEEN GIVEN SUPERVISION OR INSTRUCTION CONCERNING USE OF THE APPLIANCE BY A PERSON RESPONSIBLE FOR THEIR SAFETY.

CHILDREN SHOULD BE SUPERVISED TO ENSURE THAT THEY DO NOT PLAY WITH THE APPLIANCE.

User instructions

Installation

All the operations concerned with the installation (electrical and gas connections, adaptation to type of gas, necessary adjustments, etc.) must be carried out by qualified technicians, in terms with the standards in force. For specific instructions, kindly read the part reserved for the installation technician.

DO NOT USE OR STORE FLAMMABLE MATERIALS NEAR THIS APPLIANCE.

DO NOT SPRAY AEROSOLS IN THE VICINITY OF THIS APPLIANCE WHILE IT IS IN OPERATION.

DO NOT MODIFY THIS APPLIANCE.

The appliance is not suitable for use with aftermarket lids or covers.

WHERE THIS APPLIANCE IS INSTALLED IN MARINE CRAFT OR IN CARAVANS, IT SHALL NOT BE USED AS A SPACE HEATER.

Use

Use Gas burners

The ignition of the gas burner is carried out by putting a small flame to the upper part holes of the burner, pressing and rotating the corresponding knob in an anti-clockwise manner, until the maximum position has coincided with the marker. When the gas burner has been turned on, adjust the flame according to need. The minimum position is found at the end of the anti-clockwise rotation direction.

For models with automatic/ simultaneous (with one hand) ignition, it is sufficient to proceed as described above using the corresponding knob. The electric spark between the ignition plug and the burner provides the ignition of the burner itself. After ignition, immediately release the push-button and adjust the flame according to need. For models with a thermoelectric safety system, the burner is ignited as in the various cases described above, keeping the knob fully pressed on the maximum position for approximately 3/5 seconds. After releasing the knob, make sure the burner is actually lit.

N.B.

- We recommend the use of pots and pans with a diameter matching that of the burner, thus preventing the flame from escaping from the bottom part and surrounding the pot;
- do not leave any empty pots or pans on the fire;
- do not use any tools for grill-cooking on Crystal hobs.

When cooking is finished, it is also a good norm to close the main gas pipe tap and/or cylinder.

Dual Wok Burner

Models **ILSS775 & ILSS905** have a Dual Wok burner.

The centre flame (F1) can be lit by pressing the knob and turning it clockwise or the entire burner (F2) can be lit as shown in the figure below.

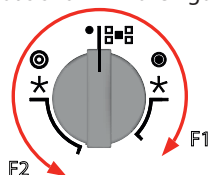

Important

On floors with thermoelectric protection do not keep the ignite button pushed for more than 15 seconds. If the burner has not ignited after 15 seconds, open the door of the room and wait at least one minute before making a further attempt.

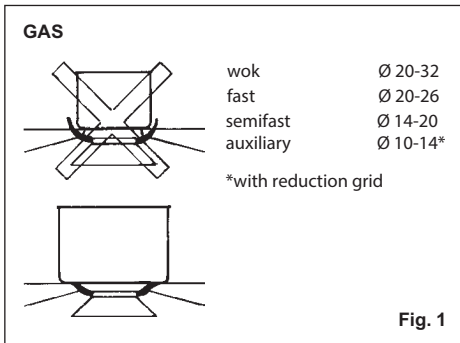

Warning: If the surface is cracked, switch off the appliance to avoid the possibility of electric shock.

Warning: Metallic objects such as knives, forks, spoons and lids should not be placed on the hob surface since they get hot.

Danger of fire: Do not store items on the cooking surface.

Caution: The cooking process has to be supervised. A short term cooking process has to be supervised continuously.

WARNING: Unattended cooking on a hob with fat or oil can be dangerous and may result in fire.

Warning: The appliance is not intended to be operated by means of external timer or separate remote control system.

Maintenance Gas/Electrical

Prior to any operation, disconnect the appliance from the electrical system. For long-life to the equipment, a general cleaning operation must take place periodically, bearing in mind the following:

- the glass, steel and/or enamelled parts must be cleaned with suitable non-abrasive or corrosive products (found on the market). Avoid chlorine-base products (bleach, etc.);
- avoid leaving acid or alkaline substances on the working area (vinegar, salt, lemonjuice, etc.);
- the wall baffle and the small covers (mobile parts of the burner) must be washed frequently with boiling water and detergent, taking care to remove every possible encrustation. Dry carefully and check that none of the burner holes is fully or partially clogged;
- the electrical parts are cleaned with a damp cloth and are lightly greased with lubricating oil when still warm;
- the stainless steel grids of the working area, after having been heated, take on a bluish tint which does not deteriorate the quality. To bring colour back to its original state, use as lightly abrasive product.

N.B.- Cleaning of the taps must be carried out by qualified personnel, who must be consulted in case of any functioning anomaly. Check periodically the state of conservation of the flexible gas feed pipe. In case of leakage, call immediately the qualified technicians for its replacement.

DO NOT USE STEAM CLEANERS

mod. ILBV604

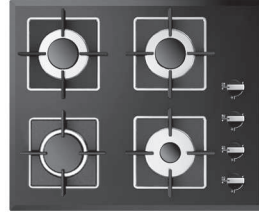
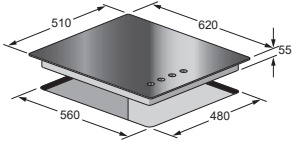

mod. ILBV775 & ILWV775

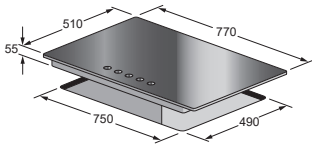

mod. ILSS775

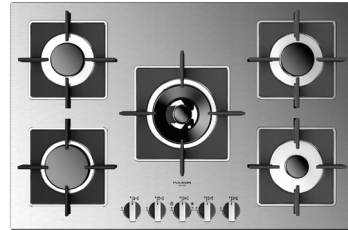
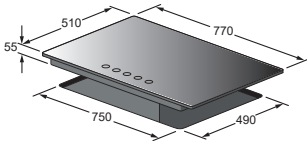
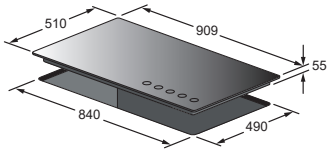

Fig. 2

mod. ILBV905 or ILWV905



mod. ILSS905

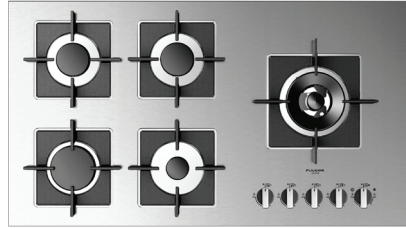
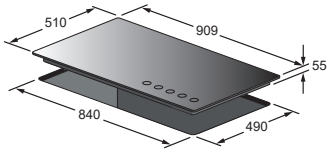
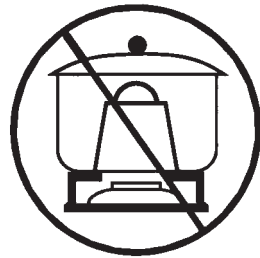
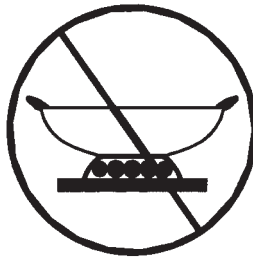
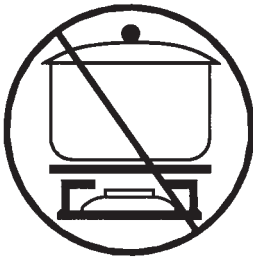

Fig. 2A



Do not place anything, e.g. flame tamer, asbestos mat, between pan and pan support as serious damage to the appliance may result.

Do not remove the pan support and enclose the burner with a wok stand as this will concentrate and deflect heat onto the hotplate.

Do not use large pots or heavy weights which can bend the pan support or deflect flame onto the hotplate.

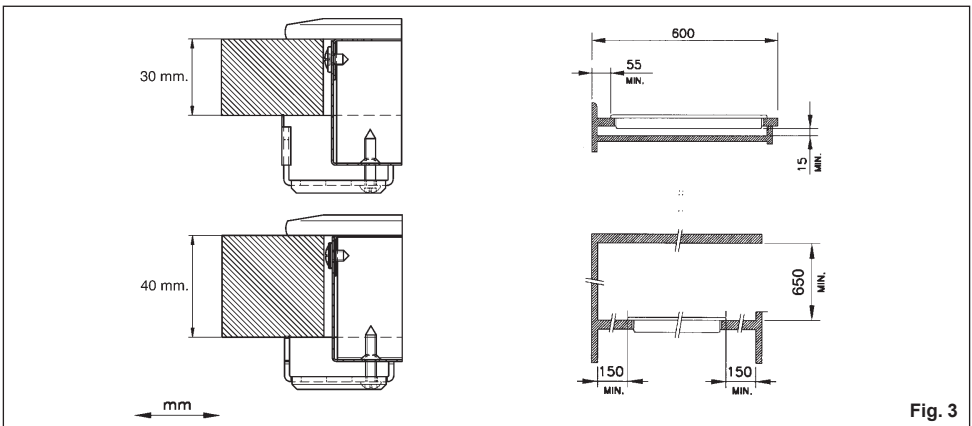

Fig. 3

Instructions for the installer

Installation

This appliance shall be installed only by authorised persons and in accordance with the manufacturer's installation instructions, local gas fitting regulations, municipal building codes, electrical wiring regulations, AS/NZS 5601 - Gas Installations and any other statutory regulations.

This appliance is not provided with a combustion product discharge. It is recommended that it be installed in sufficiently aerated places, in terms of the laws in force. The quantity of air which is necessary for combustion must not be below 2.0 m³/h for each kW of installed power. See table of burner power.

Positioning (Fig. 4)

The appliance can be fitted into a working area as illustrated on the corresponding figure. Before positioning the hob, fit the seal (X) around the entire periphery of the hole cut in the worktop.

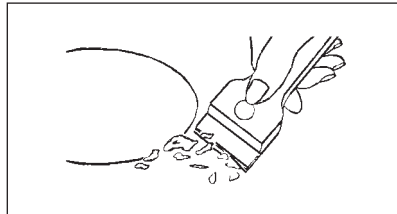

Gas connection (Fig. 5)

Connect the appliance to the gas cylinder or to the installation according to the prescribed standards in force, and ensure beforehand, that the appliance matches the type of gas available. Other wise, see "Adaptation to various types of gas". Further more, check that the feed pressure fall swithin the values described on the table: "User chacteristics".

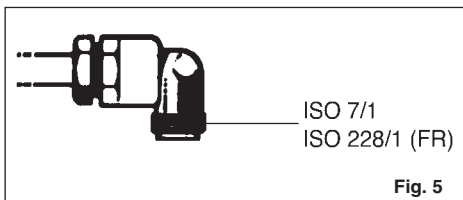

Data Label

The Data Label is located on the base of the appliance. A duplicate Data Label is supplied to adhere in an accessible area next to the appliance. This appliance is suitable for Natural Gas and ULPG; ensure that the available gas supply matches the Data Label.

There are two ways to carry out the connection to the main gas line:

A. The hotplate can be connected with rigid pipe as specified in AS/NZS5601.

B. The hotplate can be connected with a Flexible Hose, which complies with AS/NZS 1869 (Australian Certified), 10mm ID, class B or D, no more than 1.2m long and in accordance with AS/NZS 5601. Ensure that the Hose does not contact the hot surfaces of the hotplate, oven, dishwasher or other appliance that may be installed underneath or next to the hotplate. **WARNING:** Ensure that the hose assembly is restrained from accidental contact with the flue or flue outlet of an underbench oven. The hose should not be subjected to abrasion, kinking or permanent deformation and should be able to be inspected along its entire length. Unions compatible with the hose fittings must be used and connections tested for gas leaks. The supply connection point shall be accessible with the appliance installed. The hose assembly shall be suitable for connection to a fixed consumer piping outlet located at a point 800mm to 850mm above the floor and in a region outside the width of the appliance to a distance of 250mm.

Abnormal Operation

Any of the following are considered to be abnormal operation and may require servicing:

Yellow tipping of the hob burner flame.

Sooting up of cooking utensils.

Burners not igniting properly.

Burners failing to remain alight.

Burners extinguished by cupboard doors.

Gas valves, which are difficult to turn.

In case the appliance fails to operate correctly, contact the authorised service provider in your area*.

Electrical connection (Fig. 6)

Prior to carrying out the electrical connection, please ensure that:

- the plant characteristics are such as to follow what is indicated on the matrix plate placed at the bottom of the working area;
- that the plant is fitted with an efficient earth connection, following the standards and law provisions in force. The earth connection is compulsory in terms of the law.

Should there be no cable and/or plug on the equipment, use suitable absorption material for the working temperature as well, as indicated on the matrix plate. Under no circumstance must the cable reach a temperature above 50°C of the ambient temperature.

If connecting directly to the mains power supply, fit a multi-pole switch of a suitable size for the rated capacity with a clearance distance which completely disconnects the power line under overvoltage category III conditions, consistently with the rules of installation (the yellow/green earth wire must not be interrupted). The plug or omnipolar switch must be easily reached on the installed equipment.

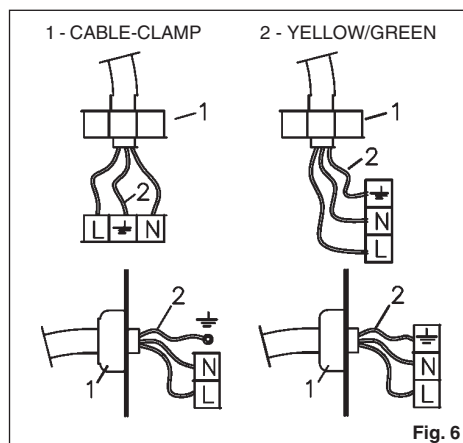

To avoid all risk, if the power cable becomes damaged, it must only be replaced by the manufacturer, by an authorised service centre, or by a qualified electrician.

Adaptation to various types of gas (Fig. 7)

Should the appliance be pre-set for a different type of gas than available, proceed as follows:

- replace the injector (Fig. 7) with the corresponding type of gas to be used (see table "User characteristics");

- to adjust to the minimum, use a screwdriver on the screw placed on the tap (Fig. 8) after turning the tap to its minimum position.

For GPL (butane/propane) screw tight.

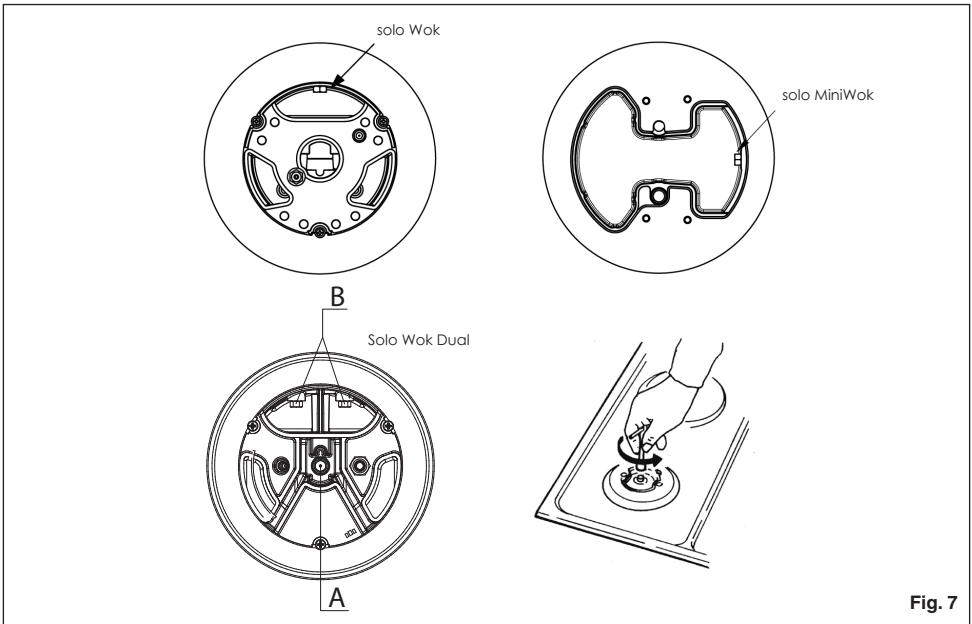

Fig. 7

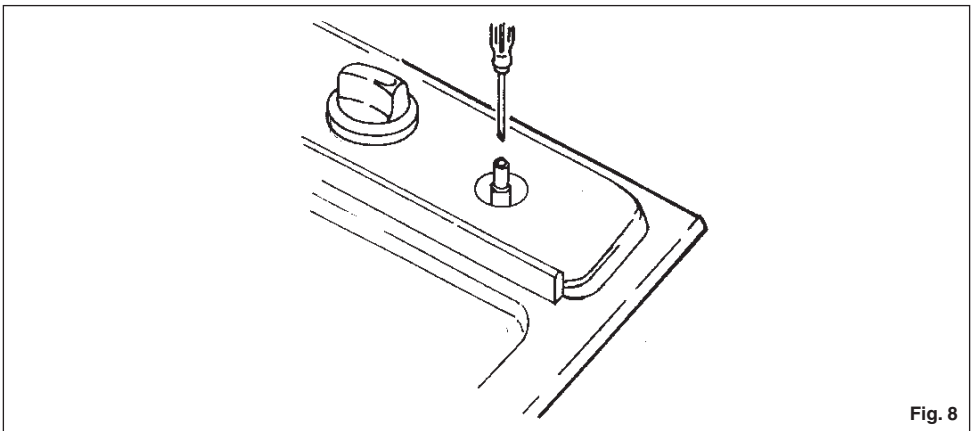

Fig. 8

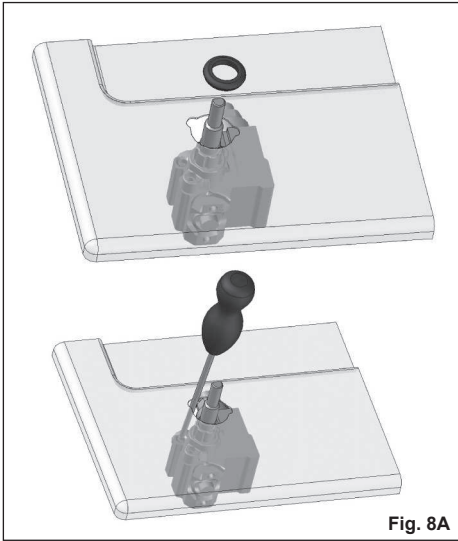

Fig. 8A

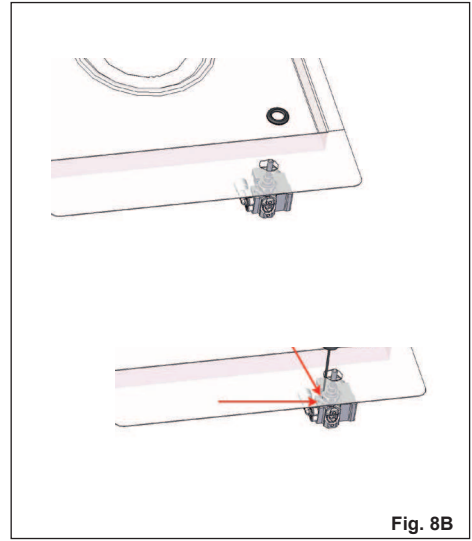

Fig. 8B

Before Leaving

Check all connections for gas leaks with soap and water. DO NOT use a naked flame for detecting leaks. Ignite all burners both individually and concurrently to ensure correct operation of gas valves, burners and ignition. Turn gas taps to low flame position and observe stability of the flame for each burner individually and concurrently. When satisfied with the hotplate, please instruct the user on the correct method of operation. In case the appliance fails to operate correctly after all checks have been carried out, refer to the authorised service provider in your area.

USER CHARACTERISTICS			
GAS BURNERS			
TYPE PRESSURE mbar NORM.	BURNER	Ø INJECTORS 1/100	NOMINAL GAS CONSUMPTION MJ/h
Natural gas 1.00 kPa	fast	155	11.7
	semifast	117	6.9
	auxiliary	92	4.1
	Wok (single control)	180	14.4
	Wok Dual	80 (inner) 130 (outer)	3.2 (inner) 17.5 (outer & inner)
Universal LPG 2.75 kPa	fast	94	11.9
	semifast	70	6.5
	auxiliary	56	4.1
	Wok (single control)	108	14.4
	Wok Dual	48 (inner) 70 (outer)	2.9 (inner) 16.0 (outer & inner)



Australia National Telephone Number 1300 MYILVE (694 583)
New Zealand Telephone Number 0508 458 369

ILVE showrooms are open daily from 9am-5pm and Saturdays 10am-4pm
(WA by appointment only on Saturdays)

ilve.com.au

NSW & ACT (Head Office)
48-50 Moore Street
Leichhardt
F 02 8569 4699

VIC, TAS & SA
1211 Toorak Road
Camberwell
F 03 9809 2155

QLD
1/42 Cavendish Road
Coorparoo
F 07 3397 0850

WA & NT
Unit 10/55 Howe Street
Osborne Park
F 08 9201 9188

New Zealand
PO Box 11.160
Sockburn Christchurch
F 03 344 5906

