

**VEVOR<sup>®</sup>**

**Diaphragm Pump  
Instruction Manual**

# VEVOR<sup>®</sup>

## Diaphragm Pump

NMDP52-G55-70-12

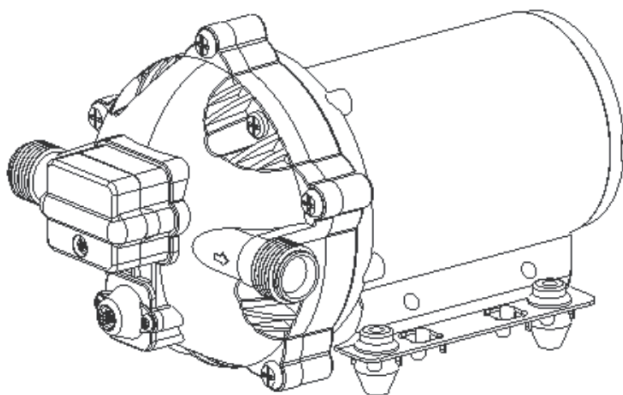

### NEED HELP? CONTACT US!

Have product questions? Need technical support?  
Please feel free to contact us:



[CustomerService@vevor.com](mailto:CustomerService@vevor.com)

This is the original instruction, Please read all manual instructions carefully before operating. VEVOR reserves clear interpretation of our user manual. The appearance of the product shall be subject to the product you received. Please forgive us that we won't inform you again if there is any technology or software updates on our product.

An economical workhorse, the 52 Series is engineered for flexibility. The 5-chamber series are our Heavy-Duty water pump. It provides high-volume water flow with reduced pump cycling, thanks to the large five-chamber diaphragm. With the on-demand switch, 5.5 GPM, and 70 PSI, the 52 Series will meet your special requirements with positive predictable performance. With a built-in bypass function, the 52 Series can reduce rapid cycling and allow water to flow back from the outlet side to the inlet side of the pump. We also offer a variety of easy-connect fittings and filters.

## PRODUCT SPECIFICATIONS

Propey	Specifications
Rated Voltage	12V
Rated Pressure	70 PSI
Number of Chamber 5 PCS	5 PCS
Max. Flow	5.5 GPM
Inlet/Outlet Diameter	1/2" MNPT

An incredible feature list, high-quality components, plus amazing performance. The five-chamber high-volume design, driven by a heavy-duty motor produces flow rates of 5.5 GPM, capable of self-priming up to 6 vertical feet, and can run dry, making it the price-to-performance leader. This pump also offers a variety of easy-connect fittings and filters.

## FEATURES

- 5 -chamber diaphragm pump
- Continuous duty
- Industry-standard mounting pattern
- Run dry capable for normal workloads
- Automatic: controlled by pressure switch
- Self priming
- Quiet Operation
- Ignition protected Bypass: reduces cycling

## APPLICATIONS

- Yacht/RV/caravan pressurized water system
- Sprayer fixtures (vehicle-mounted sprayers, electric sprayers)
- Cleaning machines Humidifiers water purification, medical apparatus
- Food beverage filling & liquid transfer
- Solar water system
- Any other pressurization system

## INSTALLATION

### Materials

1. diaphragm pump with related accessories
2. (at least) pieces of flexible, reinforced hose piping, with collapsing strength of twice the inlet collapsing pressure (hose must be minimum 1/2" ID)
3. stainless steel hose clamps and screws
4. screws to fasten the pump to the mounting surface
  - 1 electrical cut off switch
  - 1 fuse
  - 1 screwdriver
  - 1 strong cutting implement for tubing (if desired) Teflon tape or sealant

### Setup

1. The pump may be mounted in any position. If mounted vertically, the pump head should be in the down position to avoid leakage into the motor casing in the event of a malfunction.
2. Secure the feet, but do not compress them. Over tightening the securing screws may reduce their ability to dissipate noise and vibration.
3. The inlet and outlet hoses must be 1/2" (13 mm) ID reinforced hoses. The diameter of branch and individual supply lines from the outlet should be no smaller than 3/8" (10 mm).
4. Plumb the system using high pressure (2 x pump rating), braided, flexible tubing to minimize vibration/noise.
5. Do not apply inlet pressure in excess of 30psi. In general, try to avoid any inlet pressure completely.
6. Avoid any kinks or fittings which could cause excessive restrictions.
7. Strainer should be attached to the inlet side.
8. The fittings must be secured to avoid leakage
9. Use clamps at both ends of the hose to prevent air leaks into the water line.
10. If a check valve is installed in the plumbing, it must have a cracking pressure of no more than 2 psi.
11. If applying a sealer or plumbing tape, be careful to not over tighten, as they may be sucked into

12. This pump should be wired on its own dedicated circuit. Connect the positive lead (red) to the positive terminal of your battery and the negative wire (black) to the negative terminal of your battery.
13. In an easily accessible location, install a switch to control electricity to the pump. Turn the pump off when not used for extended periods or when the tank is empty.
14. The electrical circuit should be protected with an over-current protection device (fuse) in the positive lead. This pump requires a 15 amp fuse.
15. The pump circuit should not include any other electrical loads.
16. As the water supply pump is non-essential, reference the wire Chart under the electrical information. Be sure to have the correct wire sizing for the length of wire you are using.
17. After installation, check the voltage at the pump motor. Voltage should be checked when the pump is operating. Full voltage must be available at the pump motor at times.

## Notes

1. Flexible potable water hose or PEX tubing is recommended instead of rigid piping at the pump. If you choose to use rigid piping, provide a short length of hose between the pipe and the pump to avoid noise and vibration.
2. We do not recommend the use of metal fittings. When possible, use the provided plastic fittings.
3. Do not adjust the bypass personally without the help of a technician.
4. Lack of sanitizing and maintenance is one of the main reasons for the underperformance of the pump. Please do maintenance and winterize the pump at appropriate times, especially before and after a period of storage.

## ACCESSORIES

Item	Quantity
Hose Adapter	2
Filter	1
Hexagon Bolt	1
Sealing Tape	1
3/4" Copper Hose Adapter	1

## EXPLODED VIEWS

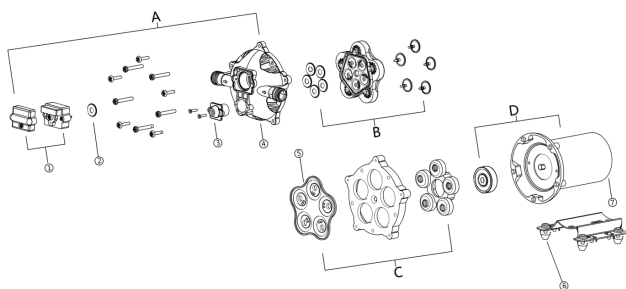

KEY	Description	Quantity
1	Pressure Switch	1
2	Diaphragm of Pressure Switch	1
3	Bypass Switch	1
4	Pump Head	1
5	Diaphragm	1
6	Iron Feet Group	1
7	Motor	1

## PRODUCT SIZE

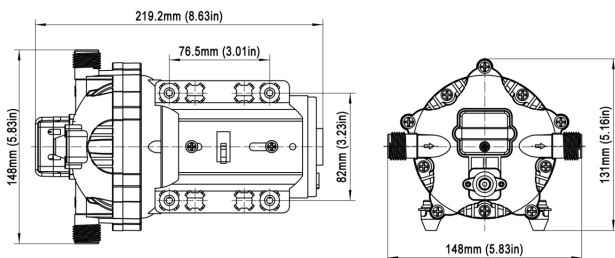

## TROUBLESHOOTING

### PULSATING FLOW— PUMP CYCLES ON AND OFF

- Check lines for kinks.
- Plumbing lines or fittings may be too small.
- Clean faucets and filters.
- Check fitting tightness for air leaks.

### FAILURE TO PRIME BUT MOTOR OPERATES - NO PUMP DISCHARGE

- Restricted in take or discharge line .
- Air leak in intake line.
- Punctured pump diaphragm
- The initial amp supply is not enough to sufficiently start the motor.
- Debris clogs in the valves .
- Crack in the pump housing.

### MOTOR FAILS TO TURN ON

- Loose or improper wiring.
- The pump circuit has no power.
- Blown fuse.
- Failed pressure switch.
- Defective motor.

### PUMP FAILS TO TURN OFF AFTER ALL FIXTURES ARE CLOSED

- Punctured diaphragm.
- Discharge line leak
- Defective pressure switch.
- Insufficient voltage.
- Clogged valves in the pump head.

### LOW FLOW AND PRESSURE

- Air leak at the pump intake.
- Accumulation of debris inside pump or plumbing.
- Worn pump bearing (possibly accompanied by loud noise).
- Punctured diaphragm
- Defective motor.

## NOISY

- Check if the mounting feet are compressed too tightly.
- Is the mounting surface flexible? If so, it may be adding noise.
- Check for loose head/screws.
- If the pump is plumbed with rigid pipe, then it may transmit noise more easily.

## USE THE FOLLOWING PROCESS TO ADJUST SHUT-OFF AND BY-PASS PRESSURES

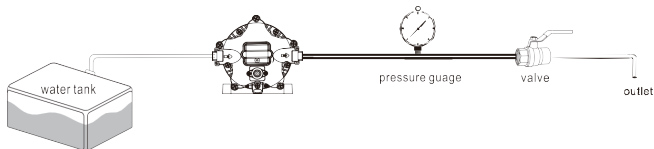

1. Install the pump as in picture 1.

## ADJUSTING THE BYPASS VALVE AND PRESSURE SWITCH

 **TIP:** Bypass adjustment should be performed by a professional technician using a proper gauge and equipment. Without the proper equipment, you could mis-adjust the valve or switch causing the pump to work improperly (see Caution below).

### About the Bypass Valve

The pump uses a spring-loaded bypass valve to maintain smooth performance as water demands rise and fall. When a faucet is turned on the pump is providing full water flow, so the bypass valve is closed. But when there is little to no water demand, the bypass valve opens to allow water to flow back from the outlet side to the inlet side, keeping a steady flow of water within the pump with almost no cycling.

### ADJUSTING THE PUMP'S SHUT-OFF PRESSURE:(1)

- To raise the shut-off pressure, use a 2mm Allen wrench to turn the pressure switch screw clockwise to the desired pressure.
- To lower the shut-off pressure, use a 2mm Allen wrench to turn the pressure switch screw counter-clockwise to the desired pressure.

### ADJUSTING THE BYPASS: (2)

- To raise the pressure at which the bypass starts and raise the full bypass pressure, use a 2mm Allen wrench to turn the bypass screw clockwise to the desired pressure.
- To lower the pressure at which the bypass starts and lower the full bypass pressure, use a 2mm Allen wrench to turn the bypass screw counter-clockwise to the desired pressure.

## CAUTION:

The pressure setting for full bypass must be at least 8psi higher than the shut-off pressure of the pump. If the switch and bypass is adjusted too closely, the bypass and switch shut-off can overlap and the pump will not shut off.

picture 2

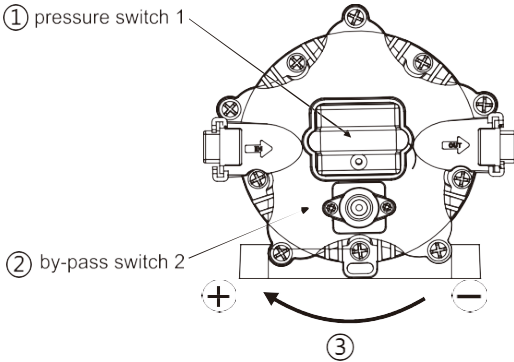

## ABOUT THE BYPASS

Please consult a professional technician in case the bypass needs adjustment. Improper adjustment of the bypass may damage the pump.

The bypass comes preset for optimal operation of the pump. If your application calls for a different setting for the bypass, you may change it yourself. Carefully tighten the screw to increase or loosen the screw to decrease the minimum operating pressure of the bypass.

## CAUTION

Please do follow the instruction manual to install the product. Any action outside what is recommended in this manual may bring damage to the pump. Any inappropriate installation or operation that causes the pump damage is not covered by warranty.

## FCC INFORMATION

This device complies with Part 15 of the FCC Rules. Operation is subject to the following two conditions:(1)This device may not cause harmful interference, and (2)thisdevice must accept any interference received , including interference that may cause undesired operation.

This product is subject to the provision of European Directive 2012/19/EC. The symbol showing a wheelie bin crossed through indicates that the product requires separate refuse collection in the European Union. This applies to the product and all accessories marked with this symbol. Products marked as such may not be discarded with normal domestic waste, but must be taken to a collection point for recycling electrical and electronic devices



\*There are any minor changes to the numbers included in the user manual without prior notice.

Manufacturer: Xiamen Newmao Pump Co., Ltd  
Add: 2nd Pak of Zone III, Floor 3, Main Building of Huaxin General Facto;; No. 216, Huanzhu Road, Qiaoying Street, Jimei District,Xiamen



**VEVOR**<sup>®</sup>

E-mail: [CustomerService@vevor.com](mailto:CustomerService@vevor.com)