

dynaudioacoustics

MF15 Owner's Manual

Table of contents

▪ 1: Product Safety and Conformity	3
▪ 2: Introduction	5
▪ 3: Installation	6
▪ 3.1: Electrical Installation	7
▪ Speaker Cables	7
▪ Signal Wiring	7
▪ 3.2: Positioning	8
▪ 3.3: Mounting	9
▪ Option 1: Bracket mounting	9
▪ Option 2: Flat mounting	9
▪ 4: Setting up and adjusting	11
▪ 4.1: First time power up	12
▪ 4.2: Running in	13
▪ 4.3: Testing and alignment	14
▪ 5: Protection	15
▪ 6: Care and Maintenance	16
▪ 7: Servicing & Spare parts	17
▪ 8: Technical Specifications	18



1: Product Safety and Conformity

The MF15 is a professional loudspeaker intended for professional users working in a professional environment; therefore, a certain level of knowledge of audio equipment operation is assumed.

About this guide

Used expressions and symbols

In this guide, the following signs and symbols are used:



The exclamation point within an equilateral triangle is intended to alert the user to the presence of important operating and maintenance (servicing) instructions in the literature accompanying the product.

WARNING

Indicates, in combination with a safety sign, a potentially hazardous situation which, if not avoided, could result in death or serious injury.

Important safety instructions

1. Read these instructions.
2. Keep these instructions.
3. Heed all warnings.
4. Follow all instructions.
5. Do not use this apparatus near water.
6. Clean only with a dry cloth.
7. Do not install near any heat sources such as radiators, heat registers, stoves, or other apparatus (including amplifiers) that produce heat.
8. Only use attachments/accessories specified by the manufacturer.
9. Use only with the cart, stand, tripod, bracket, or table specified by the manufacturer, or sold with the apparatus. When a cart is used, use caution when moving the cart/apparatus combination to avoid injury from tip-over.
10. No naked flame sources, such as lighted candles, should be placed on the apparatus.

WARNING

To reduce the risk of fire or electric shock, this apparatus should not be exposed to rain or moisture and objects filled with liquids, such as vases, should not be placed on this apparatus.

WARNING

Our speakers are very heavy. Ensure appropriate lifting methods are employed when moving them.

WARNING

Never place a loudspeaker in an unstable location. A loudspeaker may fall, causing serious personal injury or death. Use only appropriate stands or brackets to mount the loudspeaker.

High sound pressure levels

To prevent possible hearing damage, avoid listening at high volume levels for extended periods of time.

Unpacking

After unpacking, ensure the system is complete and inspect the device and all accessories for any transport damage. Transport damage may be expected if the packaging is already severely damaged. Do not attempt to start up a damaged device.

If the contents are incomplete or damaged, please contact your Dynaudio distributor.

Distributor addresses can be found on the Internet at dynaudio.com.

Removing the protection cap

The tweeter is protected by a cap to prevent damage during transport and unpacking. After you have unpacked the speaker, remove the cap by just pulling it straight out.

Packaging material

The packaging has been designed to be reusable, provided it has not been damaged during transport. Keep the original packaging and use it for all further transport.

CE declaration of conformity

The CE declaration of conformity can be found online:

<https://dynaudio.com/support/ce-conformity-declarations>

Correct disposal of this product

This marking on the product, accessories, packaging or literature indicates that the product and its electronic accessories should not be disposed of with other household waste as stated in the European Directive 2012/19/EU on Waste Electrical and Electronic Equipment (WEEE). The crossed-out bin symbol is printed on all products as a reminder.

By ensuring this product is disposed of correctly, you will help prevent potential negative consequences for the environment and human health. Recycling of materials helps to conserve natural resources.

Household users should contact either the retailer where they purchased this product or their local government office for details on where and how to recycle these items in an environmentally safe manner.

Business users should contact their supplier and check the terms and conditions of the purchase contract. This product and its electronic accessories should not be mixed with other commercial wastes for disposal.

Waste may be taken to a special collection site or can be delivered free of charge to the dealer when purchasing a new equivalent or without obligation to make a new purchase for equipment smaller than 25 cm.

2: Introduction

The MF15 is a 2-way passive speaker designed as a high-quality, compact surround speaker. It would typically complement speakers from our M series to make a superb surround monitoring system for Dolby Atmos and other immersive formats.

It is typically used with one of our four-channel amplifiers, such as the DA20 or DA40-ND.

The speaker is available in both vertical and horizontal versions, allowing you to choose the one that suits your particular installation.

The MF15 has a limited bass response by design. This is fine for small rooms, but when used in larger rooms, bass management should be used, which is recommended by Dolby Laboratories anyway.

3: Installation



3.1: Electrical Installation

In view of the “custom” nature of every installation for a speaker of this type, no cabling is supplied. The following are required for the electrical installation of the MF15 system.

Speaker Cables

The connections between the speaker and amplifier should be kept as short as possible. The cable itself should be high-quality speaker cable, eg 2.5 mm², 4mm² or 6mm² oxygen-free multi-strand copper. The speaker terminations are on Gold screw down terminals.

The outputs of the amplifiers are on speakON connectors.

Signal Wiring

The amplifier inputs are balanced XLR connections. Always ensure that only high-quality XLR cables are used for connection to the amplifiers. Typical system wiring configurations are shown in Figures 2 and 3.

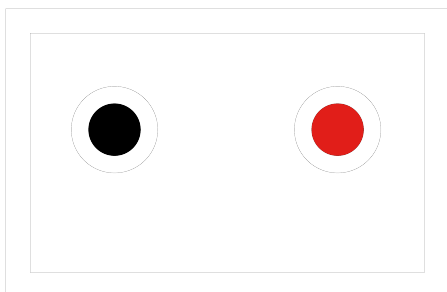

Figure 1: MF15 Connector panel. Red indicates +ve.

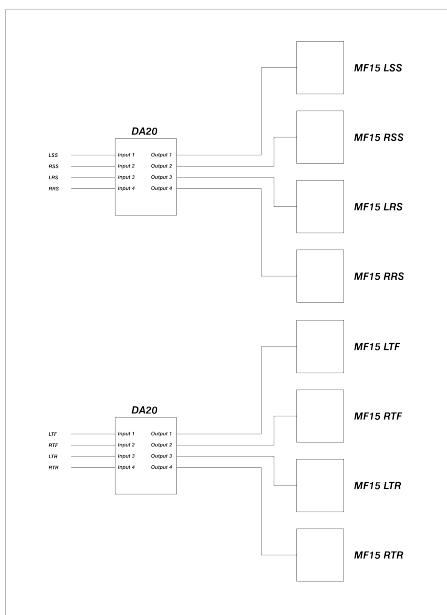

Figure 2: Typical 8-channel surround schematic as might be seen in a Dolby Atmos HE 7.1.4 system



3.2: Positioning

The MF15 loudspeaker is intended to be part of a surround speaker system, such as Dolby Atmos or a similar system.

The surround format guidelines in use will therefore determine the position of each MF15 in the room.

The optimum distance from the speaker to the listener is between 1 and 5 meters.

The acoustic centre of the MF15 is midway between the bass and HF drivers. This point should ideally be angled towards the mixing position both horizontally and vertically to ensure the efficient acoustical summing of all the drivers. There is, however, some tolerance on this if space for angling the speaker is limited.

If the studio is seeking approval and licensing from Dolby, THX or a similar entity, then these parties or qualified acoustic consultants should be consulted prior to installation, so that their specific requirements can be met.

3.3: Mounting

The back of the MF15 features four M8 fixing points arranged in a 75 mm x 75 mm square. These can be used to attach a variety of brackets to the speaker (see drawing below).

WARNING

Fixing screws should not extend more than 30 mm into the cabinet.

WARNING

If these fixing points are not used, then fit screws into them to prevent air leakage.

Option 1: Bracket mounting

The hole spacing matches a Plate type 90 made by Powerdrive. They offer a wide range of wall and ceiling brackets and pole clamps with the plate 90 attached for simple mounting of the speaker.

<https://mypowerdrive.com/products>

Option 2: Flat mounting

If you want to mount the speaker flat to a wall or ceiling, use the DA MF15FIX mounting kit.

This comprises a flat plate that is larger than the MF15 (in the short dimension), which is fixed to the back of the MF15 using four M8 fixings. This then provides a flange on each side of the speaker to secure it to a wall or ceiling.

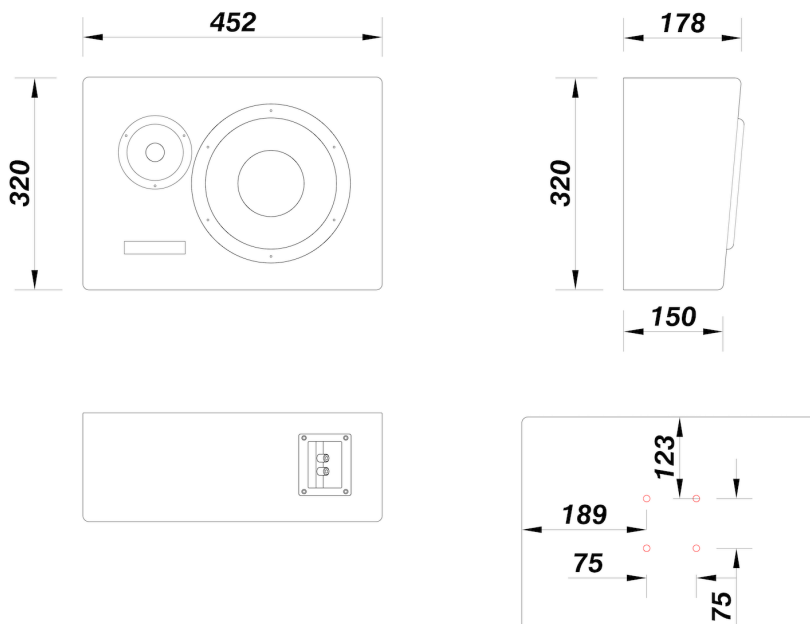

Figure 3a: MF15c compact surround speaker. Left and Right are normally mirrored.

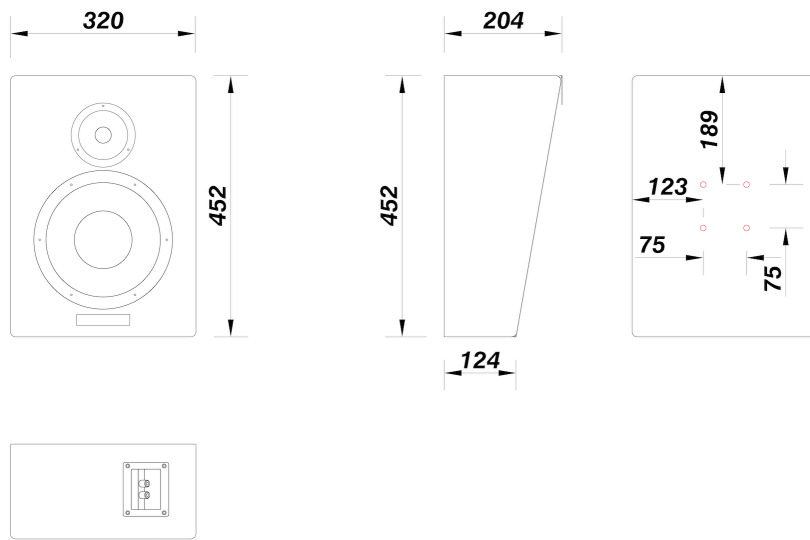

Figure 3b: MF15v compact surround speaker.



4: Setting up and adjusting

4.1: First time power up

Check that the system has been wired and set up according to the previous instructions, then simply switch on the amplifier. Check for any hum or buzz, then play some music into the system at a low level. Verify that routing and phasing are correct, then increase the level to a moderate level.

4.2: Running in

Running in is essential before any judgments are passed or the system is subjected to the maximum level. Failure to observe this can permanently damage the drivers, resulting in degraded performance for the system's lifetime. The easiest way to run a system in is to set the level controls roughly by ear as above, then connect a continuous music source (eg, a CD player in repeat mode) and leave it to run for at least 12 hours at medium volume levels. This will achieve a minimum of running in. The system will be run in fully after 5 to 6 days of continuous use. Note that if the system is left unused for a period of time (days), it may take a few minutes to return to normal performance after being switched on.

4.3: Testing and alignment

There is essentially nothing to adjust in this speaker. As part of a surround system, we would expect a front-end processor to be in place (eg, Avid MTRX), which will cover filtering, room equalisation, gain control, and time alignment.

Setup and alignment of the surround system should be carried out by a suitably qualified engineer with knowledge of room acoustics and speaker system commissioning.

5: Protection

The cones of the LF drivers will be seen to move during normal playback. However, if this gets to a point where the curved rubber surround is straightening out, then driver damage is likely.

The passive crossover features a self-resetting fuse on the HF unit, providing some protection against long-term overloading. It is a slow-reacting device, however, so it will not protect against high-level transients, pops, and thumps.

If the HF unit stops working, turn the level down to its lowest setting, then wait for a while. If the fuse has operated, it should come back on.

If audible distortion is heard, this is a good sign that the speaker and/or amplifier is being overdriven. Turn it down.

6: Care and Maintenance

High-quality components are used in the MF15, which should provide a long, trouble-free life. Here are a few hints to help them on their way.

- Never touch the drive units, especially the tweeter, which is very easily damaged. If the speakers are being moved or work is going on nearby, replace the plastic tweeter protection domes that came with the system.
- Avoid running the system into clipping or distortion. The amplifiers have clipping indicators on their front panels. When an amplifier clips, it can send potentially damaging DC components to the drive units. They may not fail immediately, but prolonged exposure to clipping will ultimately lead to failure. Set limiters to prevent this from occurring.
- Avoid unplugging or switching off any equipment that is connected to the monitor system without first muting the crossovers or switching off the amplifiers. Large spikes are often generated when equipment is switched off, which will be amplified to a potentially damaging level.
- The amplifier power provided with the MF15 is specified at a level to offer the best possible reproduction of dynamics and short-term transients, and as such is capable of damaging the system if run continuously at high levels.
- The very low distortion of these monitors means that it is easy to reach high SPLs without realising it. This can be potentially damaging to both the monitors and the user's ears. Take care of your monitoring levels.

7: Servicing & Spare parts

Drive units have been designed with easy replacement in mind. In the unlikely event that a replacement is required for any of these parts, contact your dealer. They will supply you with the appropriate Dynaudio Acoustics spare parts.

MF15 spare part numbers	Contents
DA 81622	Single tweeter
DA 87581	Single bass driver

Please quote these references when ordering spares.

If you have trouble obtaining parts from your local dealer, don't hesitate to get in touch with the Dynaudio service centre:

<https://dynaudio.com/faq/kb-tickets/new>

Do not send any goods directly. Always contact us first.

WARRANTY

This product is guaranteed against defects in materials and workmanship for 2 years from the date of purchase. This warranty is void if the unit has been tampered with or modified in any way, or in our opinion, has not been used in accordance with the instructions above.

8: Technical Specifications

Size	MF15C: 320 (H) × 452 (W) × 178 (D) mm
-	MF15v: 452 (H) × 320 (W) × 204 (D) mm
Drivers	1 × Dynaudio 24 cm MSP Bass (10 inch)
-	1 × Dynaudio Esotec Tweeter (1 inch)
Impedance	4 ohm
Connectors	4 mm Binding Posts as standard (Options Available)
Crossover	The system uses a high-efficiency passive network with a crossover frequency of 2000 Hz
Amplification	Amplifiers of 100 W to 400 W/ch – 4 ohm would normally be specified.
Frequency response	60 Hz to 20 kHz (±3 dB, room dependent)
Typical peak SPL	114 dB @ 1 m, 1 cabinet driven
T.H.D.	less than 1% at 90dB
Weight	10 kg

🔄 2025-11-28

