

Save This Manual
For Future Reference

SEARS

**owner's
manual**

**MODEL NO.
113.234650**

**10" CONTRACTOR
MITER SAW**

Serial
Number _____

Model and serial numbers
may be found at the side of
the miter saw arm.

You should record both
model and serial number in
a safe place for future use.

CAUTION:
**READ ALL
INSTRUCTIONS
CAREFULLY**

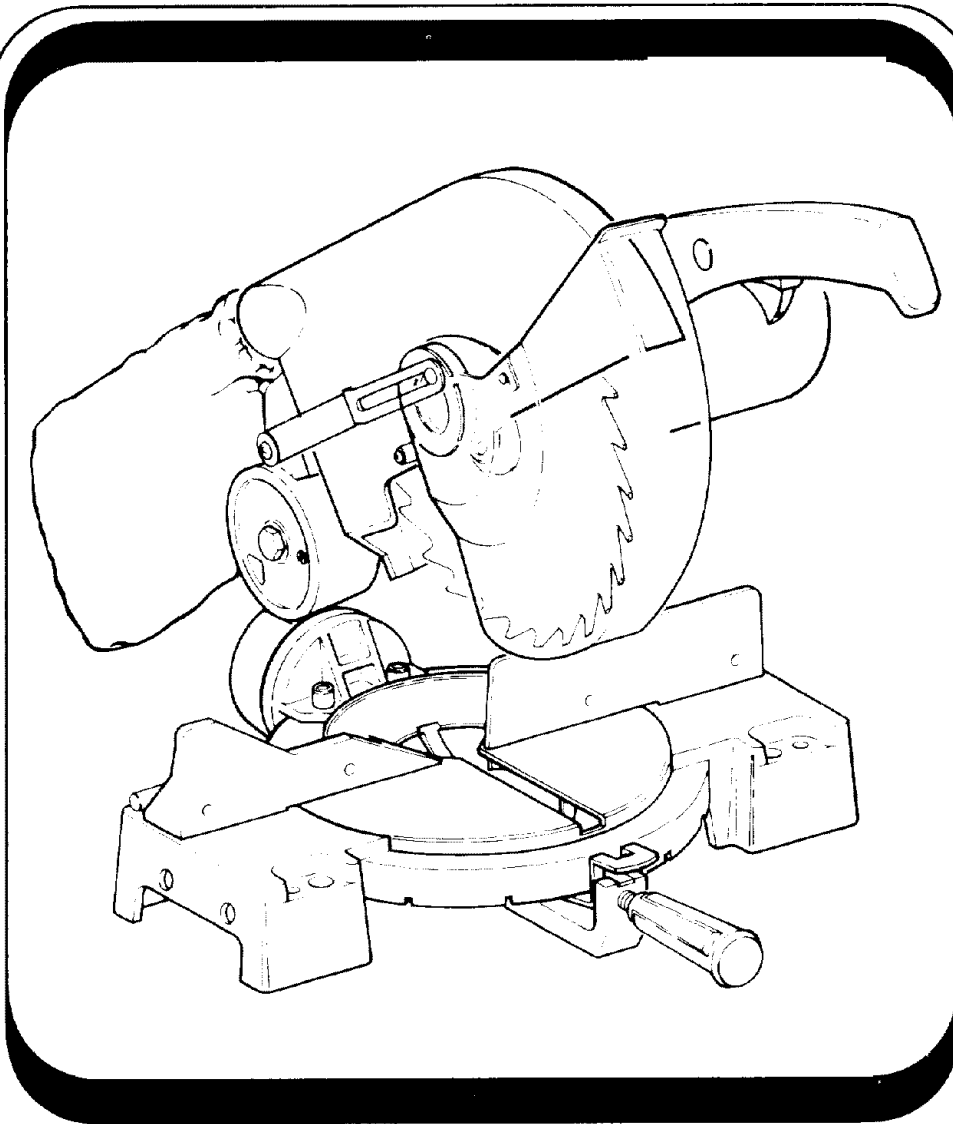

CRAFTSMAN

10-INCH CONTRACTOR MITER SAW

- assembly
- operating
- repair parts

Sold by SEARS, ROEBUCK AND CO., Chicago, IL 60684 U.S.A.

Part No. SP5229

Printed in Taiwan.

FULL ONE YEAR WARRANTY ON CRAFTSMAN MITER SAW

If within one year from the date of purchase, this Craftsman Miter Saw fails due to a defect in material or workmanship, Sears will repair it, free of charge.

WARRANTY SERVICE IS AVAILABLE BY SIMPLY CONTACTING THE NEAREST SEARS SERVICE CENTER/DEPARTMENT THROUGHOUT THE UNITED STATES.

This warranty applies only while this product is used in the United States.

This warranty gives you specific legal rights, and you may also have other rights which vary from state to state.

SEARS, ROEBUCK AND CO., Dept. 698/731A, Sears Tower, Chicago, IL 60684

GENERAL SAFETY INSTRUCTIONS FOR POWER TOOLS

- 1. KNOW YOUR POWER TOOL**
Read and understand the owner's manual and labels affixed to the tool. Learn its application and limitations as well as the specific potential hazards peculiar to this tool.
- 2. This tool is DOUBLE INSULATED** to give you added protection. Double insulation does not take the place of normal safety precautions when operating this tool. When servicing this double insulated tool, use only identical parts.
- 3. KEEP GUARDS IN PLACE**
In working order, and in proper adjustment and alignment.
- 4. REMOVE ADJUSTING KEYS AND WRENCHES**
Form habit of checking to see that keys and adjusting wrenches are removed from tool before turning it on.
- 5. KEEP WORK AREA CLEAN**
Cluttered areas and benches invite accidents. Floor must not be slippery due to wax or sawdust.
- 6. AVOID DANGEROUS ENVIRONMENT**
Don't use power tools in damp or wet locations or expose them to rain. Keep work area well lighted. Provide adequate surrounding work space.
- 7. KEEP CHILDREN AWAY**
All visitors should be kept a safe distance from work area.
- 8. MAKE WORKSHOP CHILD-PROOF**
With padlocks, master switches, by removing starter keys, or storing tools where children can't get them.
- 9. DON'T FORCE TOOL**
It will do the job better and safer at the rate for which it was designed.
- 10. USE RIGHT TOOL**
Don't force tools or attachment to do a job it was not designed for.
- 11. WEAR PROPER APPAREL**
Do not wear loose clothing, gloves, neckties, or jewelry (rings, wrist watches) to get caught in moving parts. NONSLIP footwear is recommended. Wear protective hair covering to contain long hair. Roll long sleeves above the elbow.
- 12. USE SAFETY GOGGLES (HEAD PROTECTION)**
Wear safety goggles (must comply with ANSI Z87.1) at all times. Everyday eyeglasses are not safety glasses. They only have impact resistant lenses. Also, use face or dust mask if cutting operation is dusty, and ear protectors (plugs or muffs) during extended periods of operation.
- 13. SECURE WORK**
Use clamps or a vise to hold work when practical. It frees both hands to operate tool.
- 14. DON'T OVERREACH**
Keep proper footing and balance at all times.
- 15. MAINTAIN TOOLS WITH CARE**
Keep tools sharp and clean for best and safest performance. Follow instructions for lubricating and changing accessories.
- 16. DISCONNECT TOOLS**
Before servicing; when changing accessories such as blades, bits, cutters, etc.
- 17. AVOID ACCIDENTAL STARTING**
Make sure switch is in "OFF" position before plugging in.
- 18. USE RECOMMENDED ACCESSORIES**
Consult the owner's manual for recommended accessories. Follow the instructions that accompany the accessories. The use of improper accessories may cause hazards.
- 19. NEVER STAND ON TOOL OR ITS STAND**
Serious injury could occur if the tool is tipped or if the cutting tool is accidentally contacted. Do not store materials above or near the tool such that it is necessary to stand on the tool or its stand to reach them.
- 20. CHECK DAMAGED PARTS**
Before further use of the tool, a guard or other part that is damaged should be carefully checked to ensure that it will operate properly and perform its intended function. Check for alignment of moving parts, binding or moving parts, breakage of parts, mounting, and any other conditions that may affect its operation. A guard or other part that is damaged should be properly repaired or replaced.
- 21. NEVER LEAVE TOOL RUNNING UNATTENDED**
Turn power off. Don't leave tool until it comes to a complete stop.

additional safety instructions for miter saw

Safety is a combination of common sense, staying alert and knowing how your miter saw works.

BEFORE USING THE SAW:

WARNING: TO AVOID MISTAKES THAT COULD CAUSE SERIOUS, PERMANENT INJURY, DO NOT PLUG THE SAW IN UNTIL THE FOLLOWING STEPS HAVE BEEN SATISFACTORILY COMPLETED.

1. Assembly and alignment.
2. Learn the function and proper use of:
 - a. The on-off switch.
 - b. The upper and lower blade guards.
 - c. The arbor lock and handle latch.
 - d. The bevel clamp, fence clamps, and miter lock handle.
3. Read and understand all safety instructions and operating procedures throughout the manual.
4. Read the following label on the miter saw:

⚠ DANGER	FOR YOUR OWN SAFETY:	Know this tool — Read and Understand the Owner's Manual before using this tool.
■ Wear safety goggles complying with ANSI Z87.1	■ Never reach behind or beneath the sawblade	
■ Tighten arbor screw and all clamps before sawing.	■ Wait for blade to stop before moving workpiece, servicing or adjusting tool.	
■ Keep guards in place and working properly	■ To avoid electrical shock, do not expose to rain.	
■ Keep hands out of sawblade path		
■ Never cut anything "free hand."		
DOUBLE-INSULATED		UL
When servicing use only identical replacement parts		Electrical 120 volts 60 Hz AC only, 15 amps 4900 RPM E85575

WHEN INSTALLING OR MOVING THE SAW:

1. To avoid injury from unexpected saw movement:
 - a. Place the saw on a firm level surface where there is plenty of room for handling and properly supporting the workpiece.
 - b. Support the saw so the table is level and the saw does not rock.
 - c. Bolt or clamp the saw to its support.
2. Before moving the saw, lock the miter, bevel and power-head positions. Unplug electric cord.
3. To avoid back injury, get help when you need to lift the saw more than 10 inches. Hold the tool close to your body. Bend your knees so you can lift with your legs, not your back. Lift by using the hand-hold areas at the bottom of the base. **Never** carry the tool by the cord or power head handle. Damage to insulation could cause an electric shock. Damage to wire connections could cause a fire.
4. Place the saw so others will stay out from behind it. Thrown debris could injure people in its path.

BEFORE EACH USE:

1. Inspect your saw. If any part of this miter saw is missing, or bent, or has failed in any way, or any electrical parts don't work properly, turn the saw off and unplug the saw. Replace damaged, missing, or failed parts before using the saw again.
2. Plan Your Work to protect your eyes, hands, face, ears.
 - a. Wear safety goggles (not glasses) that comply with ANSI Z87.1 (shown on package). Using any

power tool can result in foreign objects being thrown into the eyes, which can result in permanent eye damage. Safety goggles are available at Sears retail catalog stores. Use of glasses or use of goggles not in compliance with ANSI Z87.1 could result in severe injury from breakage of the eye protection.



- b. For dusty operations, wear a face shield along with safety goggles.
- c. To avoid injury from jams, slips or thrown pieces:
 1. Choose the right 10-inch diameter blade for the material and the type of cutting you plan to do. Use this miter saw to cut **only** wood, wood-like products or soft metals like aluminum. Other materials may shatter, grab at the blade, or create other dangers.
 2. Make sure the direction of rotation arrow on the blade matches the direction arrow on the saw. The blade teeth should always point downward at the front of the saw.
 3. Make sure the blade is sharp, undamaged and properly aligned. With the saw unplugged, push the power-head all the way down. Hand spin the blade and check for clearance. Tilt the power-head to 45 degree bevel and repeat the check. If the blade hits anything, make the adjustments shown in the Maintaining Maximum Cutting Capacity section.
 4. Make sure the blade and arbor collars are clean.
 5. Make sure the collars' recessed sides are facing toward the blade.
 6. Make sure the recessed side of the blade washer (just under the arbor screw head) faces the collar.
 7. Using 1/2-inch box end wrench, make sure the arbor cap screw retaining the blade collars is firmly hand tightened.
 8. Make sure all clamps and locks are tight and there is no excessive play in any parts.
 9. Never cut **FREEHAND**:
 - a. Brace your workpiece solidly against the fence and table top so it will not rock or twist during the cut. Make sure no debris is caught beneath the workpiece.
 - b. Make sure no gaps between the workpiece, fence and table will let the workpiece shift after it is cut in two.
 - c. Use jigs, fixtures or a different tool for unstable workpieces.

10. Never cut more than one workpiece at a time.
11. Make sure the cut off piece can move sideways after it's cut off. Otherwise, it could get wedged against the blade and thrown violently.
12. Use extra caution with large, very small or awkward workpieces:
 - a. Use extra supports (tables, saw horses, blocks, etc.) for any workpieces large enough to tip when not held down to the table top.
 - b. Do not use this saw to cut pieces too small to let you easily hold the work while you keep the thumb side of your index (pointer) finger against the outside edge of the fence.
 - c. When cutting irregularly shaped workpieces, plan your work so it will not slip and pinch the blade. A piece of molding, for example, must lie flat or be held by a fixture or jig that will not let it twist, rock or slip while being cut.
 - d. Properly support round material such as dowel rods, or tubing. They have a tendency to roll while being cut, causing the blade to "bite." To avoid this, always use a fixture designed to properly hold your work piece.
13. Make sure there are no nails or foreign objects in the part of the workpiece to be cut.
14. Make sure bystanders are clear of the tool and workpiece. Keep them clear of the area behind the saw where debris will be thrown.
15. Never turn your miter saw "ON" before clearing everything except the workpiece and related support devices off the table.
- d. To avoid risk of hearing damage, wear ear plugs or muffs during extended periods of operation.
- e. To avoid being suddenly pulled into the blade:
 1. Do not wear gloves.
 2. Remove all jewelry and loose clothing.
 3. Tie back long hair.
 4. Roll long sleeves above the elbow.
- f. To avoid injury from accidental starting, always unplug saw before disconnecting the guard, installing or removing any blade, accessory or attachment, or making any adjustments.
- g. To avoid an electrical shock, make sure your fingers do not touch the metal prongs on the plug when inserting or removing the plug to or from a live outlet.
- h. Never put lubricants on the blade while it's spinning.
 - i. To avoid burns or other fire damage, never use the saw near flammable liquids, vapors or gases.
 - j. To avoid injury from unsafe accessories, use only accessories shown on the recommended accessories list in this manual.

WHENEVER SAW IS RUNNING:

WARNING: DON'T ALLOW FAMILIARITY (GAINED FROM FREQUENT USE OF YOUR MITER SAW) TO CAUSE A CARELESS MISTAKE. ALWAYS REMEMBER THAT A CARELESS FRACTION OF A SECOND IS ENOUGH TO CAUSE A SEVERE INJURY.

1. Before actually cutting with the saw, let it run for a while. If your saw makes an unfamiliar noise or if it vibrates excessively, stop immediately. Turn the saw off. Unplug the saw. Do not restart until finding and correcting the problem.
2. Never confine the piece being cut off. Never hold it, clamp it, touch it, or use length stops against it. It must be free to move sideways. If confined, it could get wedged against the blade and thrown violently.
3. Avoid awkward hand positions where a sudden slip could cause a hand to move into the blade.
4. Let the blade reach full speed before cutting.
5. Feed the saw into the workpiece only fast enough to let the blade cut without bogging down or binding.
6. Before freeing jammed material, release switch and unplug the saw. Wait for all moving parts to stop.
7. After finishing a cut, keep holding the power-head down, release the switch, and wait for all moving parts to stop before moving your hands.

glossary of terms for woodworking

Arbor

The shaft on which a cutting tool is mounted.

Bevel Cut

An angle cutting operation made through the face of the work piece.

Compound Cut

A simultaneous bevel and miter cutting operation.

Crosscut

A cutting operation made across the width of the workpiece.

Freehand

Performing a cut without the use of fence (guide), hold down or other proper device to prevent the workpiece from twisting during the cutting operation. Twisting of the workpiece can cause it to be thrown.

Gum

A sticky, sap based residue from wood products.

Heel

Misalignment of the blade.

Kerf

The amount of material removed by the blade in a through cut or the slot produced by the blade in a non-through or partial cut.

Miter Cut

An angle cutting operation made across the width of the work piece.

Resin

A sticky, sap based substance that has hardened.

Revolutions Per Minute (RPM)

The number of turns completed by a spinning object in one minute.

Sawblade Path

The area of the workpiece or table top directly in line with either the travel of the blade or the part of the workpiece which will be, or has been, cut by the blade.

Set

The distance that the tip of the sawblade tooth is bent (or set) outward from the face of the blade.

Workpiece

The item on which the cutting operation is being performed. The surfaces of a workpiece are commonly referred to as faces, ends, and edges.

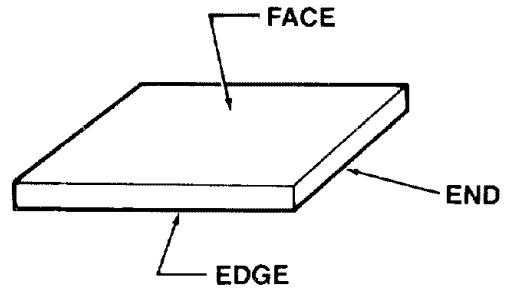

electrical connections

POWER SUPPLY

Motor Specifications

The AC motor used in this saw is a universal, nonreversible type having the following specifications:

H. P.	3
Voltage	120
Amperes	15
Hertz (Cycles)	60
Phase	Single
RPM	4900
Rotation of Shaft	Clockwise
Brake	Automatic

WARNING: TO AVOID ELECTRICAL HAZARDS, FIRE HAZARDS, OR DAMAGE TO THE TOOL, USE PROPER CIRCUIT PROTECTION. YOUR SAW IS WIRED AT THE FACTORY FOR 120V OPERATION. CONNECT TO A 120V, 15-AMP, BRANCH CIRCUIT AND USE A 15-AMP TIME DELAY FUSE OR CIRCUIT BREAKER. TO AVOID SHOCK OR FIRE, IF POWER CORD IS WORN OR CUT, OR DAMAGED IN ANY WAY, HAVE IT REPLACED IMMEDIATELY.

DOUBLE INSULATED

The miter saw is double insulated to provide a double thickness of insulation between you and the tool's electrical system. All exposed metal parts are isolated from the internal metal motor components with protecting insulation.

Your unit has a plug that looks like the one shown below.

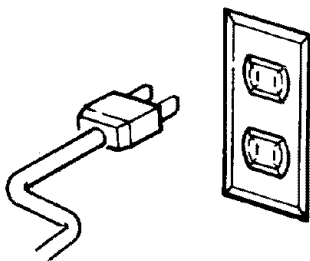

This power tool is equipped with a 2-conductor cord listed by Underwriters Laboratories (UL). The plug permits you to use any conventional 120-volt electrical

outlet without necessity for maintaining a ground connection.

CAUTION: Double insulation does not take the place of normal safety precautions when operating this tool.

DANGER: To avoid electrocution:

1. Use only identical replacement parts when servicing a tool with double insulation. Servicing should be performed by a qualified service technician.
2. Do not use in rain or where floor is wet.

This tool is intended for indoor residential use only.

MOTOR SAFETY PROTECTION

CAUTION: To avoid motor damage, this motor should be blown out or vacuumed frequently to keep sawdust from interfering with normal motor ventilation.

1. Connect this tool to a 120V, 15-amp branch circuit with a 15-amp time delay fuse or circuit breaker. Using the wrong size fuse can damage the motor.
2. If the motor won't start, release the trigger switch immediately, **UNPLUG THE TOOL**. Check the saw blade to make sure it turns freely. If the blade is free, try to start the motor again. If the motor still does not start, refer to the "Motor Trouble-Shooting Chart."
3. If the motor suddenly stalls while cutting wood, release the trigger switch, unplug the tool, and free the blade from the wood. The motor may now be restarted and the cut finished.
4. Fuses may "blow" or circuit breakers may trip frequently if:
 - a. **MOTOR IS OVERLOADED**—Overloading can occur if you feed too rapidly or make too many start/stops in a short time.
 - b. Voltages not more than 10% above or below the nameplate voltage can handle normal loads. For heavy loads, however, the voltage at motor terminals must equal the voltage specified on nameplate.
5. Most motor troubles may be traced to loose or incorrect connections, overload, low voltage (such as small size wire in the supply circuit) or to overly long supply circuit wire. Always check the connections,



the load and the supply circuit whenever motor doesn't work well. Check wire sizes and length with the Wire Size Chart below.

For circuits that are farther than 100 feet away from electrical service box, the wire size must be increased proportionately in order to deliver ample voltage to the saw motor.

WIRE SIZES

The use of any extension cord will cause some loss of power. To keep this to a minimum and to prevent overheating and motor burn-out, use the table below to determine the minimum wire size (A.W.G.) extension cord.

Length of the Conductor	Wire Sizes Required For 120V (American Wire Gage Number)
0-25 Ft.	14
26-100 Ft.	12
Over 100 Ft.	8

contents

	Page		Page
Guarantee	2	Assembly and Alignment	9
General Safety Instructions for Power Tools	2	Mounting the Saw	13
Additional Safety Instructions for Miter Saws	3	Basic Saw Operations	15
Glossary of Terms for Woodworking	4	Maintenance and Lubrication	21
Electrical Connections	5	Trouble Shooting	22
Unpacking and Preassembly	6	Repair Parts	25
Knowing Your Miter Saw	7		

UNPACKING AND PREASSEMBLY

WARNING: TO AVOID INJURY FROM UNEXPECTED STARTING OR ELECTRICAL SHOCK, DO NOT PLUG THE POWER CORD INTO A SOURCE OF POWER DURING UNPACKING AND ASSEMBLY. THIS CORD MUST REMAIN UNPLUGGED WHENEVER YOU ARE WORKING ON THE SAW.

Model 113.234650, Miter Saw is shipped complete in one box.

WARNING: ALTHOUGH SMALL, THIS SAW IS HEAVY. TO AVOID BACK INJURY, GET HELP WHENEVER YOU HAVE TO LIFT THE SAW MORE THAN 10 INCHES.

1. Remove the miter saw from the carton by lifting the saw by the base.

WARNING: IF ANY PART IS MISSING OR DAMAGED, DO NOT PLUG THE SAW IN UNTIL THE MISSING OR DAMAGED PART IS CORRECTLY REPLACED. TO AVOID ELECTRIC SHOCK, USE ONLY IDENTICAL REPLACEMENT PARTS WHEN SERVICING DOUBLE INSULATED TOOLS.

2. Place the saw on a secure stationary work surface and look the saw over carefully.

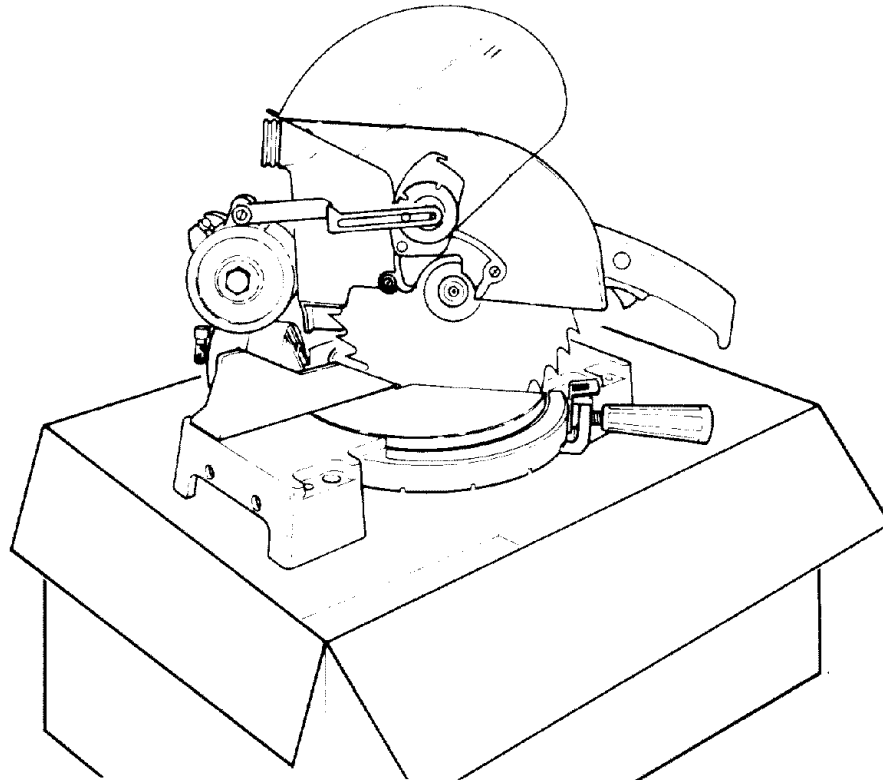

tools needed

Tools required for assembly and alignment:

- Medium Screwdriver
- #2 Phillips Screwdriver
- Combination Square
- 1/2 Box End/Open End Wrench or Socket
- 2 - 15/16 Box End/Open End Wrenches or Adjustable Wrenches or Socket Wrenches
- 5/16" Hex "L" Wrench

COMBINATION SQUARE MUST BE TRUE

DRAW LIGHT
LINE ON BOARD
ALONG THIS EDGE

STRAIGHT EDGE OF
BOARD 3/4" THICK
THIS EDGE MUST BE
PERFECTLY STRAIGHT

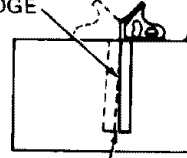

SHOULD BE NO GAP OR OVERLAP WHEN
SQUARE IS FLIPPED OVER IN DOTTED POSITION

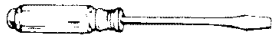

MEDIUM SCREWDRIVER



#2 PHILLIPS SCREWDRIVER

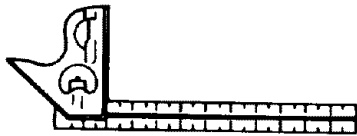

COMBINATION SQUARE



5/16" HEX "L" WRENCH

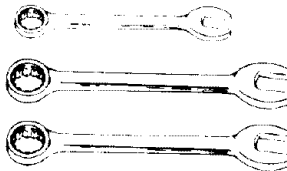

1/2" WRENCH

15/16" BOX END/OPEN END
WRENCHES



1/2" SOCKET

15/16" SOCKETS &
SOCKET WRENCHES

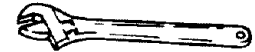

ADJUSTABLE WRENCH



knowing your miter saw

1. Warning label.
2. Handle Latch—The miter saw can be locked in the lowered position for compact storage.
3. Fence Lock Handles—The fence has two positions for increased crosscut capacity. The lock handles secure the fence to the base. The saw is shipped with the fence in the front position.

NOTE: If the fence is being used in the rear position, the two fence lock handles must be loosened before changing the miter angle. Then tighten the fence handle at the desired miter angle before starting a cut.

4. Miter Lock Handle—The miter lock handle securely locks the miter saw at a desired miter angle. Index points have been provided at 0, 22.5 R/L, and 45 R/L.
5. Bevel Lock Handle—The bevel lock handle locks the miter saw at a desired bevel angle.
6. Lower Blade Guard—The blade guard helps protect your hands from the blade in the raised position. To avoid binding on the workpiece, it retracts as the blade is lowered.
7. Miter Saw Handle—The saw handle contains the trigger switch with a lock-off button. The blade is lowered into the workpiece by pushing down on the handle. The saw will return to its upright position when the handle is released.

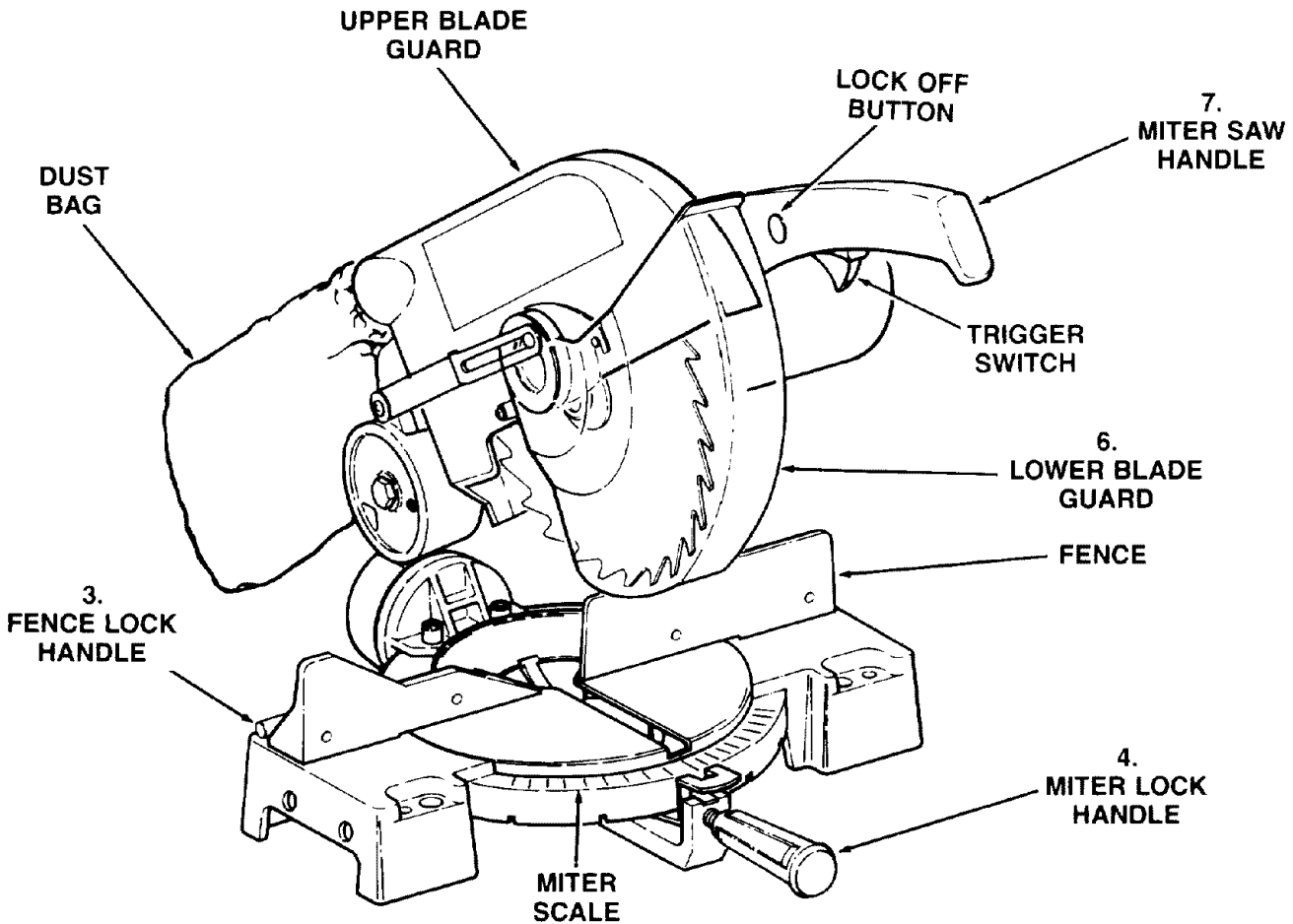
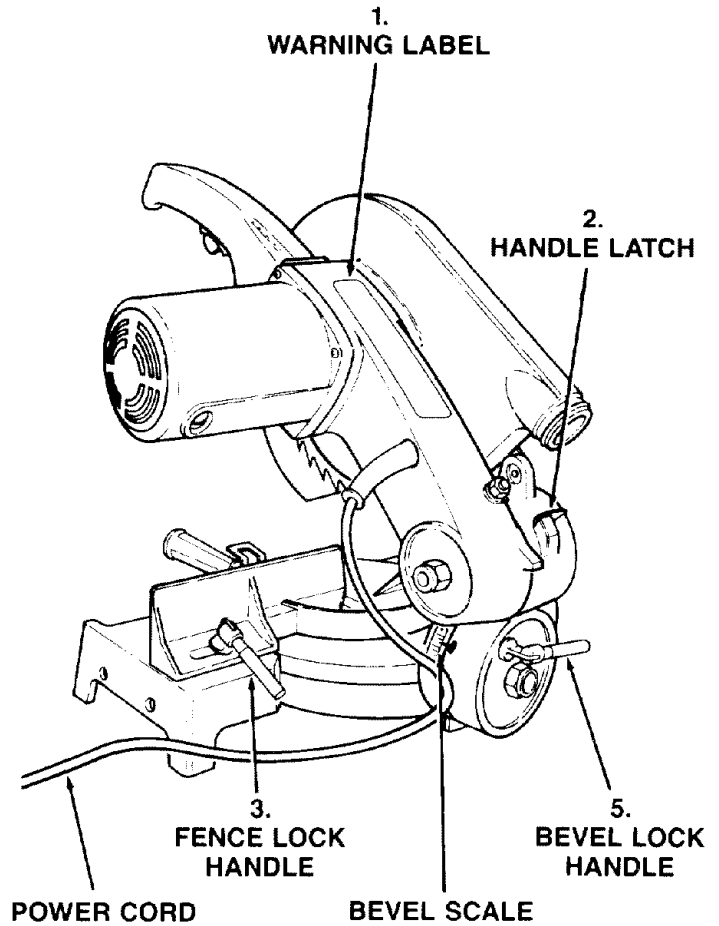

assembly and alignment

ASSEMBLY AND ALIGNMENT

Assembling the Lower Blade Guard

NOTE: For compact shipment the lower blade guard has been partially disconnected.

1. The miter saw is equipped with a handle latch used to lock the miter saw in the lowered position. To release, push the handle down slightly and turn the handle latch to the other side.
2. Release the handle latch and raise the saw to its up position.
3. Slide the lower guard assembly down until the groove in the mounting plate rests on the front screw. Tighten the screw with a phillips screwdriver.
4. Remove the 1/4-20 shoulder screw from the pivot casting as illustrated. Attach the blade guard link to the pivot casting with a phillips screwdriver.

NOTE: With the blade guard link attached, the guard should raise as the blade is lowered towards the work table and drop to cover the blade as the power head is raised. This link helps prevent guard hangups and binding while you are cutting.

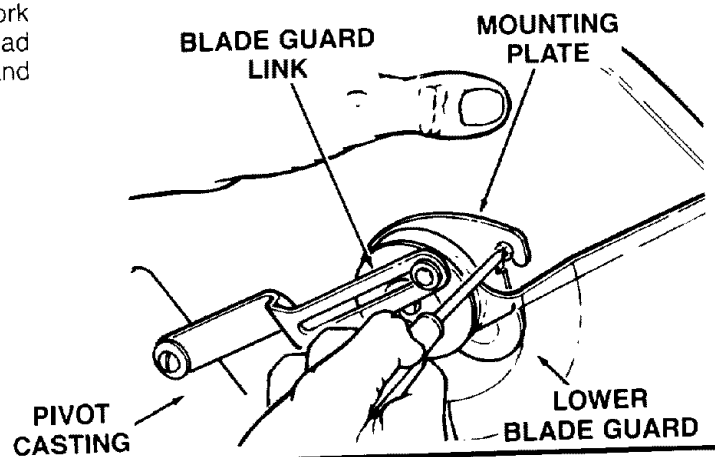
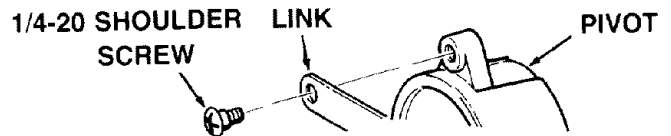
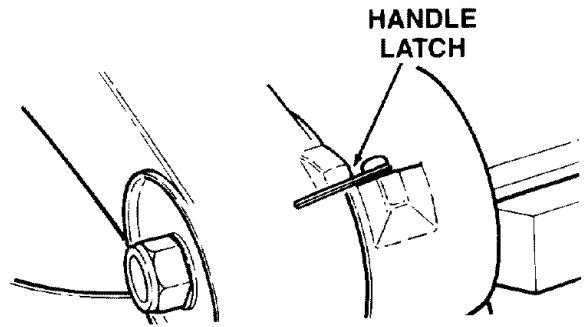

Assembly and Alignment

Assembly and Alignment

Step One—Blade Square to Table

NOTE: The miter saw was assembled, aligned, and inspected before shipment. Alignment should be checked and any adjustments made to insure accurate cuts.

1. Check miter lock handle setting. The miter lock handle should be at the 0° position. To reset the miter angle, turn the miter lock handle counter clockwise and press down the index spring.
2. Lower the blade and lock the handle latch. Use the combination square to check blade squareness to table. If the blade does not contact the full length of the square, follow the alignment procedure.
 - a. Loosen bevel lock handle.
 - b. Grasping metal upper guard, move the cutting head left or right until blade makes contact with the full length of the square.
 - c. Tighten the bevel lock handle.
3. Check the bevel indicator. If indicator needs adjustment use a phillips screwdriver and slide the indicator to the 0° on the scale.

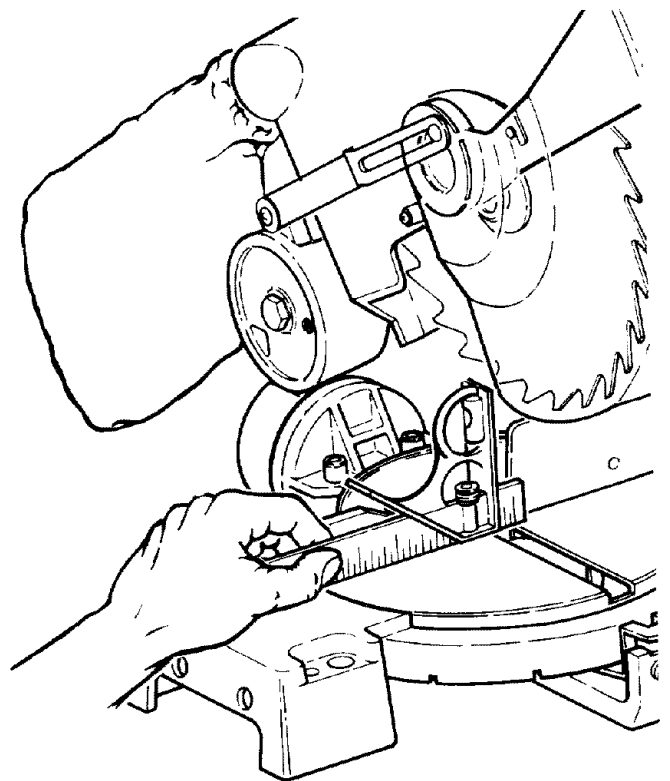

Step Two—Checking and Aligning Blade with Turn Table Slot

1. The blade should look like it's parallel to the sides of the turn table slot. The blade should be $\frac{1}{8}$ " closer to left side than right.
2. If blade looks parallel with turn table slot proceed to step three. If necessary, realign blade with turn table slot, adjust as follows.
 - a. Use a $\frac{5}{16}$ " hex "L" wrench to loosen (but do not remove) the two cap screws that attach pivot support to turn table. Move blade power-head so it is parallel with turn table slot. Securely tighten cap screws. Recheck blade position and readjust if necessary. Always check blade clearance to table when the miter saw is fully tilted to the left.

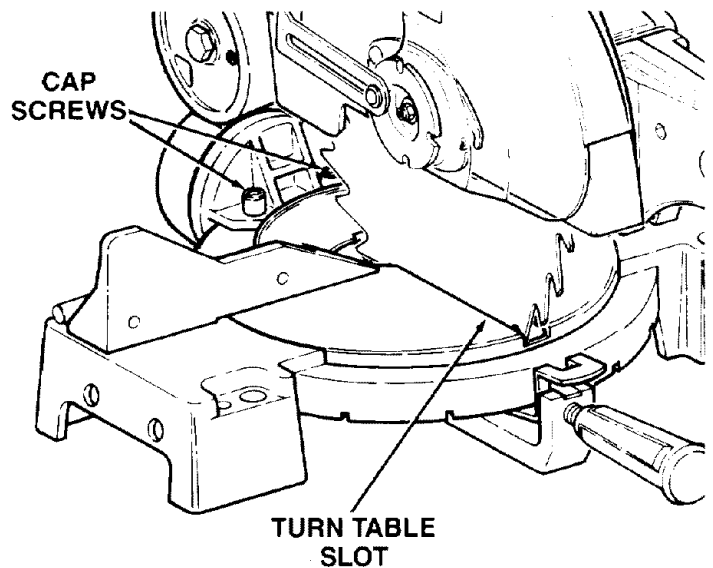

Step Three—Checking and Adjusting Blade Squareness to Fence (Front Fence Position)

1. To check blade squareness to fence, use a combination square. Place the square against the fence and next to the blade as illustrated. Place the square so the set in the teeth won't hold it from the blade. The blade should contact the full length of the square.
2. If blade contacts full length of square, proceed to next step. If blade is not square to the fence, follow the alignment procedure.
 - a. Loosen miter lock handle a half turn. The latch handle should still be secured with blade in lowered position.
NOTE: Take the saw off its stand, bench or plywood base if readjustment is necessary.

CAUTION: To keep from losing control of the unit, steady the base with one hand while loosening the two bolts with the other hand.

- b. With the unit securely resting on a large stable surface, tilt the unit by lifting up on one side or the other of the base. Loosen the two miter arm bolts on the underside of the turn table with a $\frac{1}{2}$ " wrench or socket. Tilt the unit by lifting up on one side or the other of the base.
- c. Return the saw to its normal resting position. Make sure the miter lock handle is loose but do not release the index spring.
- d. Use the miter saw handle to turn the turn table and saw so that the blade contacts the full length of the square. Watch out for tooth set. Turn the miter lock handle clockwise to lock saw square to fence.
- e. Tilt saw as in Step B and tighten bolts.
- f. Recheck blade squareness to fence and readjust if necessary.

Adjustment of Miter Scale Indicator

1. Loosen the phillips screws that hold the indicator in place. Reposition the indicator and retighten screw.

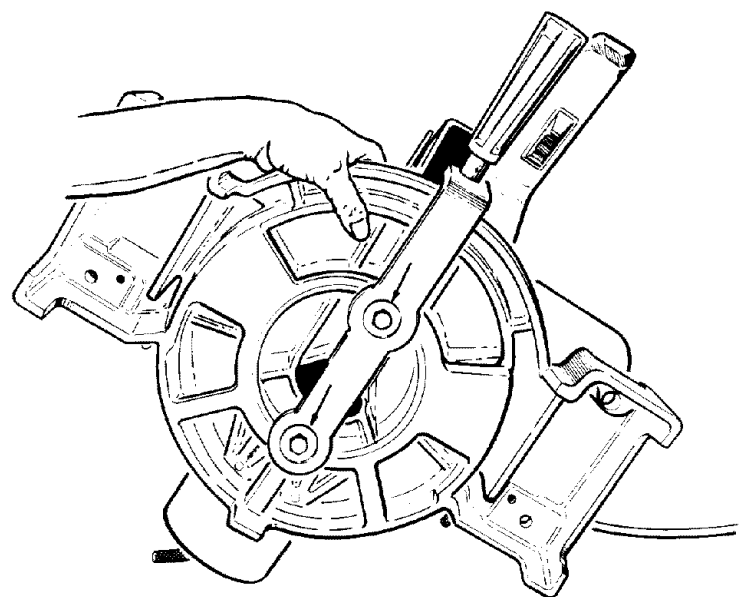
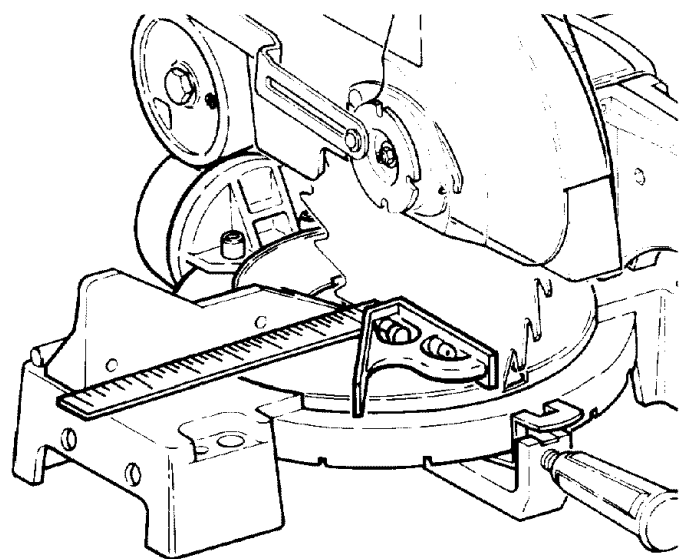

Step Four—Pivot Adjustments

NOTE: These adjustments were made at the factory and normally do not require readjustment.

1. The miter saw should rise completely to the up position by itself. If the saw will not raise by itself or if there is play in the pivot joints the following adjustments are necessary.

Travel Pivot Adjustments

- a. Hold the pivot bolt with an adjustable or $\frac{15}{16}$ " wrench. Loosen the hex lock nut with an adjustable or $\frac{15}{16}$ " wrench.
- b. Recheck the saw travel. Saw should rise freely to its up travel stop. Check to see that the saw will raise from all positions and there is no looseness in the pivot. If saw still won't fully rise, have Sears Service check and repair it.

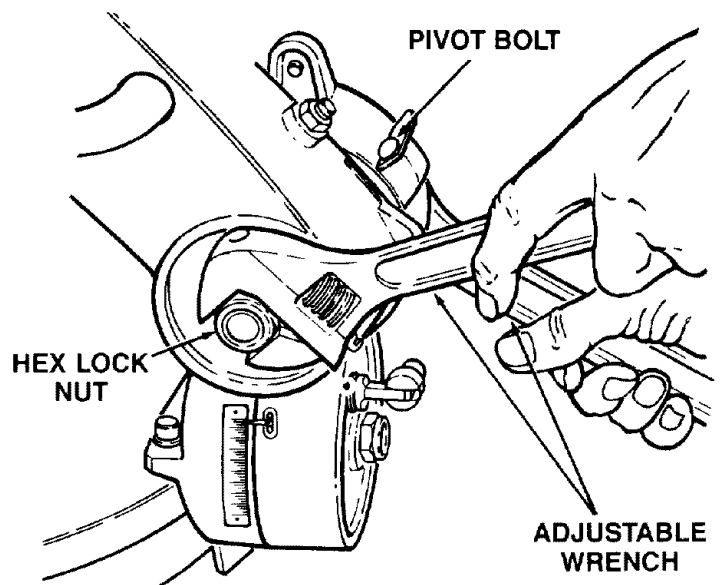

Bevel Pivot Adjustment

1. The miter saw should bevel easily by loosening the bevel lock handle and tilting the power head to the left. If movement is tight or if there is looseness in the pivot follow the adjustment procedure.
 - a. Loosen the bevel lock handle.
 - b. Turn the hex lock nut with an adjustable or $\frac{15}{16}$ " wrench.
 - c. Recheck bevel movement of the miter saw. Re-adjust if necessary.

Depth Stop

The depth stop limits the blades downward travel. It allows the blade to go below the work table enough to maintain full cutting capacities. The depth stop positions the blade $\frac{1}{4}$ " from the cast iron table support. The depth stop is factory set and should never need adjustment.

Maintaining Maximum Cutting Capacity

WARNING: TO AVOID INJURY FROM UNEXPECTED STARTING OR ELECTRICAL SHOCK, DO NOT PLUG THE SAW IN. THE POWER CORD MUST REMAIN UNPLUGGED WHENEVER YOU ARE WORKING ON THE SAW.

Unplug the saw before any adjustment is attempted.

This tool is factory set to provide maximum cutting capacity for the 10" saw blade provided. When the diameter of the blade has been reduced due to sharpening, it may be necessary to adjust depth stop to provide maximum cutting capacity. When a new blade is installed, it is necessary to check the clearance of the blade to the turn table structure.

1. To adjust the depth stop use an adjustable wrench and loosen the hex nut at the rear of the miter saw arm.
2. Use a flat blade screwdriver to adjust the depth stop adjusting bolt. The saw blade is lowered by turning the bolt counterclockwise and raised by turning the bolt clockwise.

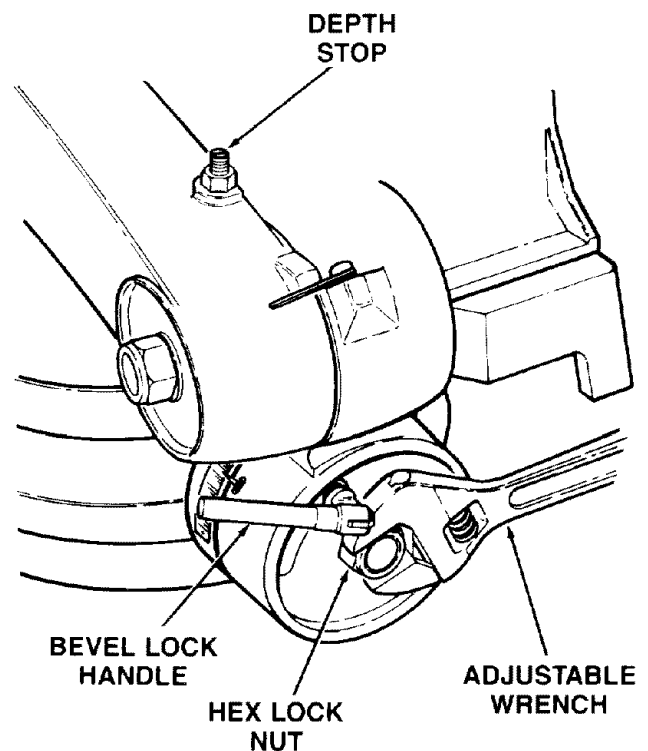

3. Lower the blade into the slot of the turn table. Check blade clearance and maximum cutting distance (distance from fence where blade enters) to front of turn table slot. Readjust if necessary.

WARNING: DO NOT START THE MITER SAW WITHOUT CHECKING FOR INTERFERENCE BETWEEN THE BLADE AND THE TURN TABLE STRUCTURE. DAMAGE COULD RESULT TO THE BLADE IF IT STRIKES THE TURN TABLE STRUCTURE DURING OPERATION OF THE SAW.

4. Tighten the hex nut with an adjustable wrench while carefully holding the depth stop adjusting bolt with the flat blade screwdriver so it will not turn while tightening hex nut.

Fence Positions

The miter saw has two fence positions. The front fence position is used for workpieces up to standard 2 x 4 for cut off and bevel operation, floor and ceiling moldings, and door casings. The rear fence position is used for cut off and bevel operation for a standard 2 x 6 workpiece.

Standard 2 x 4 measures 1½" x 3½"

Standard 2 x 6 measures 1½" x 5½"

The base on either side of the work table has two sets of holes for locating the fence. To change the fence position, remove the two fence lock handles. Put the fence in the other fence position and install the fence lock handles.

The rear fence position is designed to slide side to side when the miter setting is changed. This feature lets the fence move to provide maximum support for the workpiece. If it is necessary to change the miter cut in the rear position, first loosen the fence lock handles. Release the miter lock handle and move it to the desired miter angle. Tighten the miter lock handle and the fence lock handles.

CAUTION: Do not try to change the miter position while the fence is in the rear fence position before loosening the fence lock handles. You might damage the fence alignment arm.

On/Off Trigger Switch

To prevent the trigger from being accidentally engaged, a lock-off button is provided. To start the tool, press in the lock-off button and squeeze the trigger. Release the trigger to stop the miter saw.

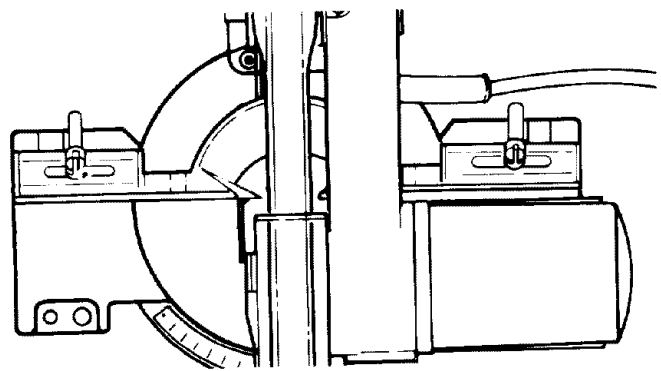

FRONT FENCE POSITION

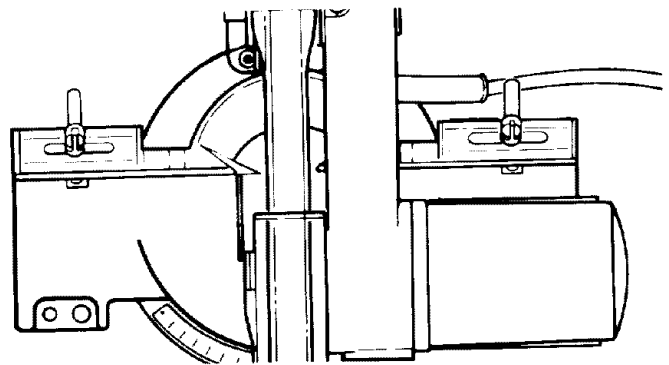

REAR FENCE POSITION

Removing or Installing the Blade

WARNING: TO AVOID INJURY FROM A THROWN WORKPIECE OR THROWN PIECES OF BLADE, DO NOT USE A BLADE LARGER OR SMALLER THAN 10" DIAMETER.

WARNING: TO AVOID INJURY FROM UNEXPECTED STARTING, UNPLUG THE SAW WHENEVER YOU ARE REMOVING OR INSTALLING THE BLADE.

1. Unplug the saw from the outlet.
2. Loosen the screw holding the lower guard mounting plate to the upper guard with phillips screwdriver.
3. Lift the lower guard up and tilt the lower guard assembly back so the arbor screw is exposed.
4. Find the arbor lock between the upper guard and the miter saw handle. Place a ½" box end wrench over arbor screw.
5. Press the arbor lock and hold it in firmly while turning the wrench **clockwise**. The arbor lock will engage after some turning of the wrench.
6. Remove the arbor screw, arbor washer, outer blade collar, and the blade.

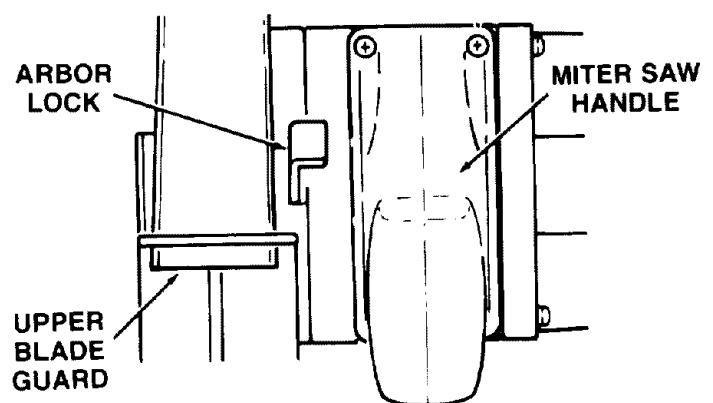
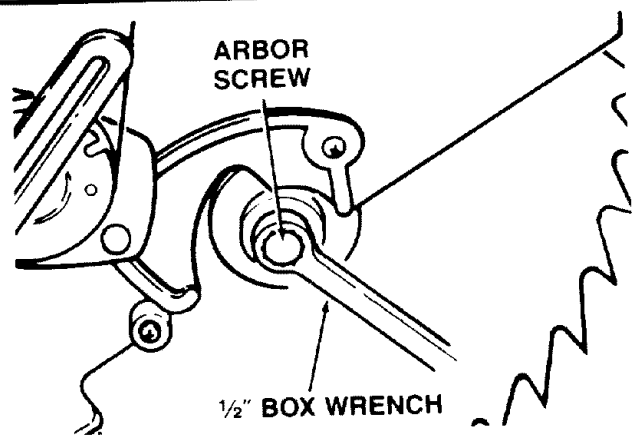

NOTE: Pay attention to pieces removed, noting their position and direction they face (see illustration). Wipe the blade collars clean of any sawdust before installing the new blades.

8. Install the new 10" blade (see recommended accessory list). Make sure the rotation arrow on the blade matches the clockwise rotation arrow on the upper guard.
9. Install the outer blade collar, arbor washer and arbor screw. Press the arbor lock and turn the 1/2" wrench counter clockwise to secure the blade. Tighten arbor screw securely.
10. Lower the lower blade guard until the slot in mounting plate rests all the way down on the locking screw. Tighten the screw with phillips screwdriver.

DANGER: NEVER USE SAW WITHOUT MOUNTING PLATE SECURELY IN PLACE. IT KEEPS THE ARBOR SCREW FROM FALLING OUT IF IT ACCIDENTALLY LOOSENS, AND PREVENTS THE SPINNING BLADE FROM COMING OFF THE MACHINE.

11. Be sure the arbor lock is released so the blade turns freely.

NOTE: The arbor lock can be damaged by improper use. If the arbor lock will not hold, lower the blade down on to a scrap piece of wood positioned against the fence. This will serve as an alternate locking means.

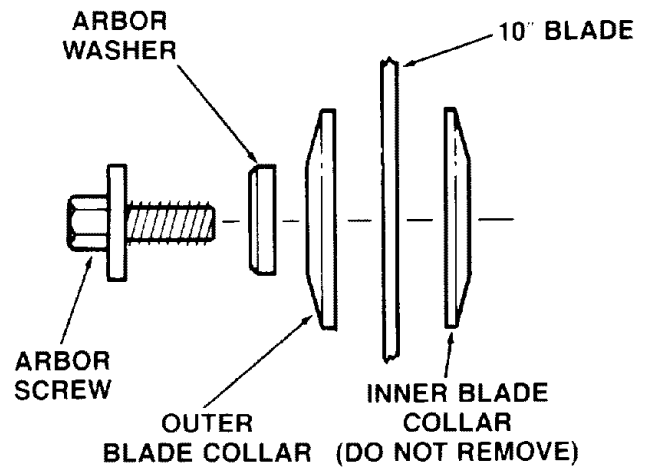

WARNING: AFTER INSTALLING A NEW BLADE, MAKE SURE THE BLADE CLEARS THE TABLE SLOT AT THE 0° AND 45° BEVEL POSITIONS. LOWER THE BLADE INTO THE LOWER TABLE AND CHECK FOR ANY CONTACT WITH THE BASE OR TURN TABLE STRUCTURE.

If blade contacts turn table, refer to assembly and alignment, step two, for adjustment.

If blade bottoms out on turn table structure, refer to assembly and alignment, depth stop section for adjustment.

(DUST BAG: REMOVED FOR CLARITY)

MOUNTING THE SAW

WARNING: TO AVOID INJURY FROM UNEXPECTED SAW MOVEMENT:

- a. Before moving the saw, lock the miter, bevel and power-head positions. Unplug electric cord.
- b. To avoid back injury, get help when you need to lift the saw more than 10 inches. Hold the tool close to your body. Bend your knees so you can lift with your legs, not your back. Lift by using the hand-hold areas at the bottom of the base.
- c. Never carry the miter saw by the power cord or the plastic handle. Carrying the tool by the power cord could cause damage to the insulation or the wire connections resulting in electric shock or fire.
- d. Place the saw so other people cannot stand behind it. Thrown debris could injure people in its path.
- e. Place the saw on a firm, level surface where there is plenty of room for handling and properly supporting the workpiece.
- f. Support the saw so the table is level and the saw does not rock.
- g. Bolt or clamp the saw to its support.

Place the saw in the desired location either on a work bench or the recommended leg set. The base of the saw has four holes to mount the miter saw (see illustration). If the saw is to be used in one location, fasten it to the work bench or leg set.

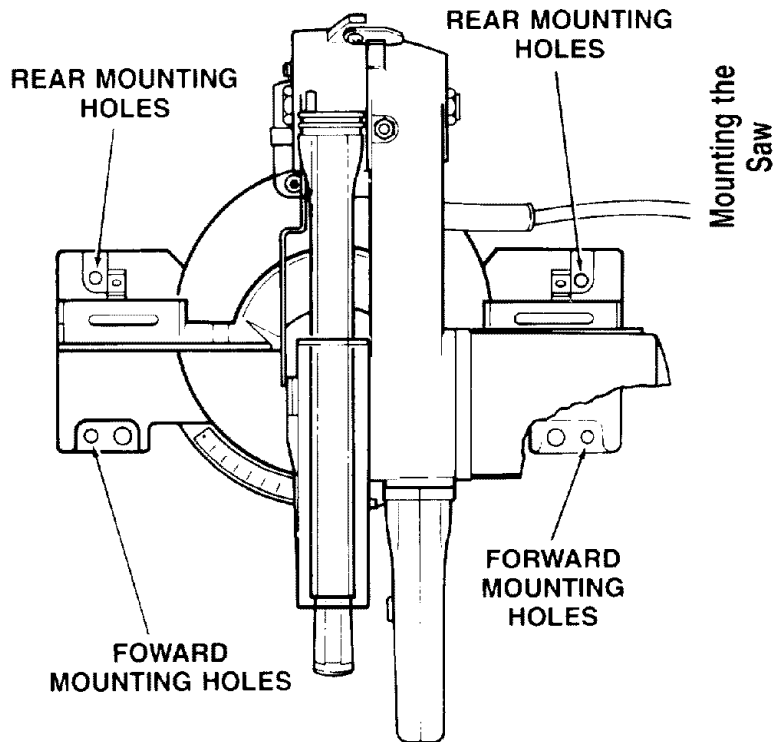

NOTE: Fence has been moved forward for access to rear mounting holes.

If the saw is to be used in a portable application, mount the saw to a 3/4" piece of plywood. The mounting board can then be clamped down to prevent it from tipping.

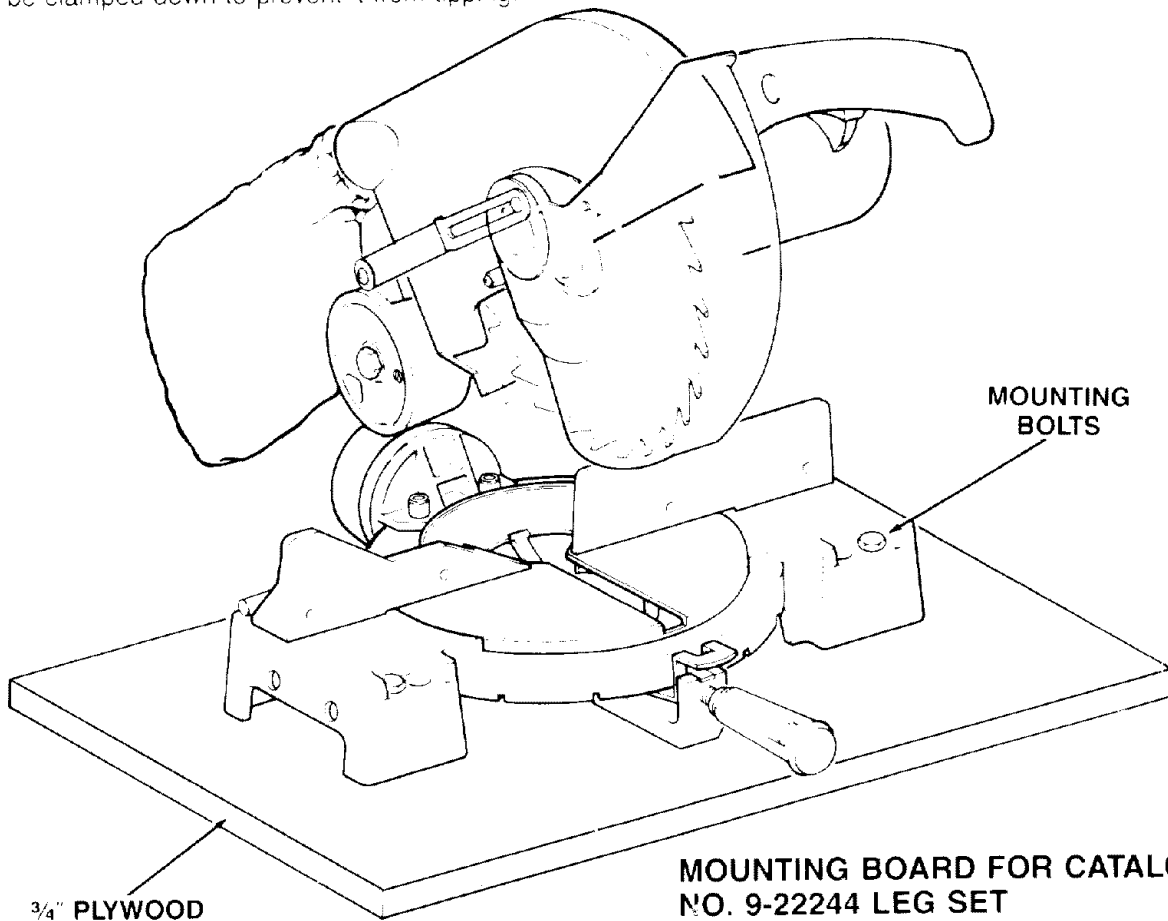

CATALOG NO. 9-22246 LEG SET MOUNTING HOLES FOR MODEL 113.234650 MITER SAW

MOUNTING BOARD FOR CATALOG NO. 9-22244 LEG SET

NOTE: Attach the mounting board to the leg set first. Then mount the miter saw to the mounting board using the recommended hardware (not included)

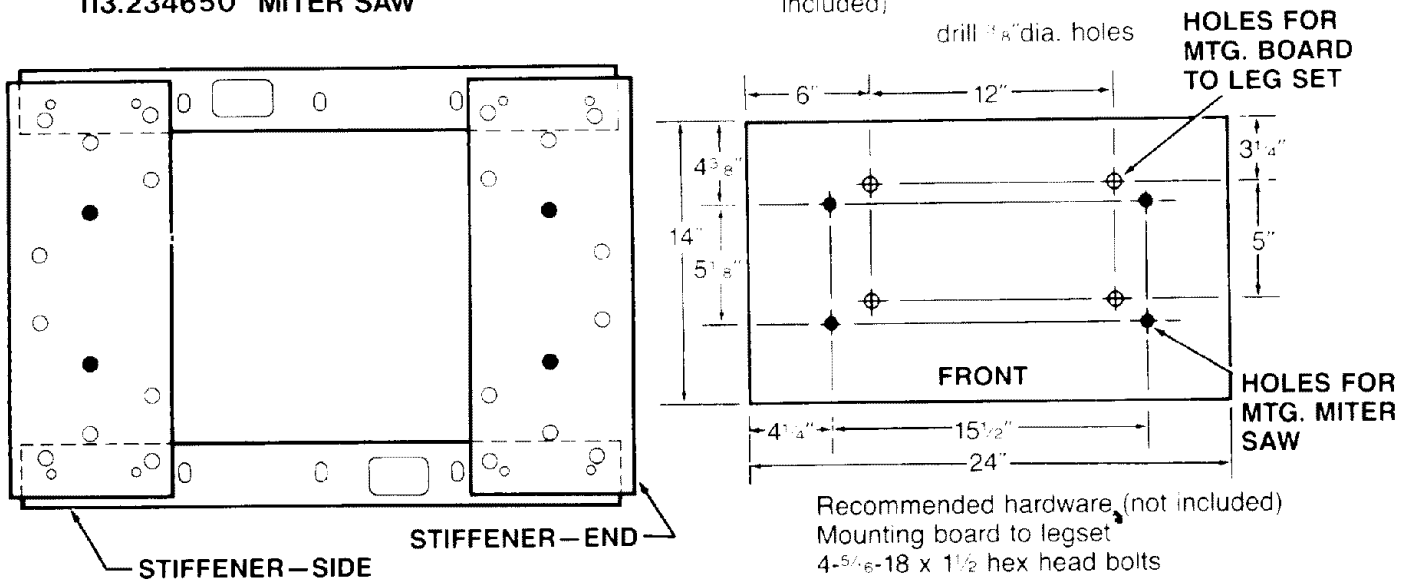

Attach miter saw to holes indicated

- Recommended mounting hardware (not included)
- 4-5/16-18 x 3 hex head bolts
 - 4-5/16 flat washers
 - 4-5/16 lock washers
 - 4-5/16 hex nuts

- Recommended hardware (not included)
- Mounting board to legset
- 4-5/8-18 x 1 1/2 hex head bolts
 - 4-5/16 flat washers
 - 4-5/16 lock washers
 - 4-5/16 hex nuts

- Mounting miter saw to mounting board
- 4-5/16-18 x 3 1/2 hex head bolts
 - 4-5/16 flat washer
 - 4-5/16 lock washer
 - 4-5/16 hex nuts



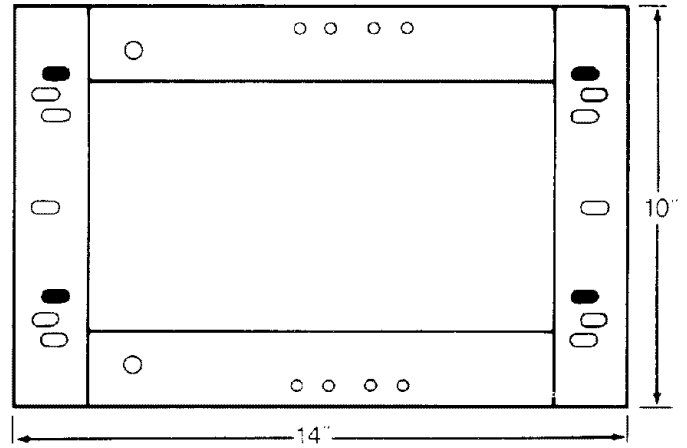
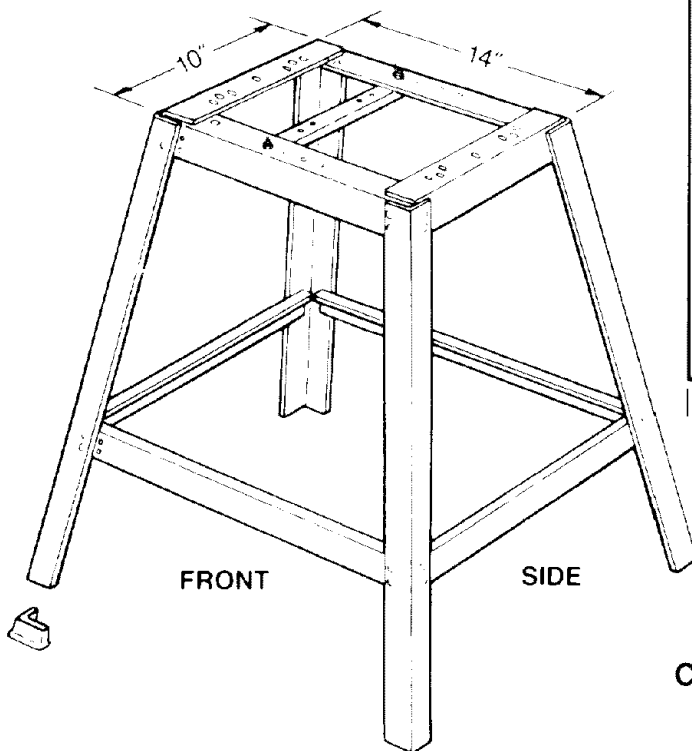

CATALOG NO. 9-22244 LEG SET

BASIC SAW OPERATIONS

WARNING: FOR YOUR OWN SAFETY, READ AND UNDERSTAND ALL SAFETY INSTRUCTIONS AND OPERATING PROCEDURES THROUGHOUT THE MANUAL BEFORE USING THIS TOOL.

BEFORE EACH USE:

1. Inspect your saw. Replace damaged, missing, or failed parts before using the saw.
2. Wear safety goggles (not glasses) that comply with ANSI Z87.1 (shown on package).
3. For dusty operations, wear a face shield along with safety goggles.
4. To avoid injury from jams, slips or thrown pieces:
 - a. Choose the right 10-inch diameter blade for the material and the type of cutting you plan to do. Use this miter saw to cut **only** wood, wood-like products or soft metals like aluminum. Other materials may shatter, grab at the blade, or create other dangers.

WARNING: IF PLANNING TO SAW ALUMINUM OR OTHER NON-FERROUS METALS:

- **UNDER ADVERSE CONDITIONS, THE BLADE CAN GRAB WORKPIECE SUDDENLY AND UNEXPECTEDLY, THIS PRESENTS RISK OF SERIOUS PERSONAL INJURY TO THE OPERATOR OR BYSTANDERS.**
- **USE ONLY SAWBLADE SPECIFICALLY RECOMMENDED FOR NON-FERROUS METAL CUTTING.**

- **THE BLADE PROVIDED WITH YOUR SAW IS NOT RECOMMENDED FOR METAL CUTTING.**
- **DO NOT CUT METAL WORKPIECES THAT MUST BE HAND HELD: USE AUXILIARY CLAMPS OR OTHER EQUIPMENT AS APPROPRIATE.**
- **OPERATOR MUST BE EXPERIENCED IN CIRCULAR SAWING OF NON-FERROUS METALS OR UNDER SUPERVISION OF AN EXPERIENCED PERSON.**

- b. Make sure the direction of rotation arrow on the blade matches the direction arrow on the saw. The teeth of the blade should always point downward at the front of the saw.
- c. Make sure the blade is sharp, undamaged and properly aligned.
- d. Make sure the blade and arbor collars are clean.
- e. Make sure the collars' recessed sides are facing toward the blade.
- f. Make sure the recessed side of the blade washer (just under the arbor screw head) faces the collar.
- g. Using a $\frac{1}{2}$ " box end wrench, make sure the arbor screw retaining the blade collars is firmly hand tightened.
- h. Make sure all clamps and locks are tight and there is no excessive play in any parts.

7. Never cut FREEHAND:
 - a. Brace your workpiece solidly against the fence and table top so it will not rock or twist during the cut. Make sure there is no debris caught beneath the workpiece.
 - b. Make sure no gaps between the workpiece, fence and table will cause shifting after the workpiece is cut in two.
 - c. Use jigs, fixtures or a different tool for unstable workpieces.
8. Never cut more than one workpiece at a time.
9. Make sure the cut off piece can move sideways after it's cut off. Otherwise, it could get wedged against the blade and thrown violently.
10. Use extra caution with large, very small or awkward workpieces:
 - a. Use extra supports (tables, saw horses, blocks, etc.) for any workpieces large enough to tip when not held down to the table top.
 - b. Do not use this saw to cut pieces too small to let you easily hold the work while you keep the thumb side of your index (pointer) finger against the outside edge of the fence.
 - c. When cutting irregularly shaped workpieces, plan your work so it will not slip and pinch the blade. A piece of molding, for example, must lie flat or be held by a fixture or jig that will not let it twist, rock or slip while being cut.
 - d. Properly support round material such as dowel rods, or tubing. They have a tendency to roll while being cut, causing the blade to "bite." To avoid this, use a fixture designed to properly hold your work piece.
11. Make sure there are no nails or foreign objects in the part of the workpiece to be cut.
12. Make sure bystanders are clear of the tool and workpiece. Keep them clear of the area behind the saw where debris will be thrown.
13. Never turn your miter saw "ON" before clearing everything except the workpiece and related support devices off the table.
14. To avoid risk of hearing damage, wear ear plugs or muffs during extended periods of operation.
15. To avoid being suddenly pulled into the blade:
 - a. Do not wear gloves.
 - b. Remove all jewelry and loose clothing.
 - c. Tie back long hair.
 - d. Roll long sleeves above the elbow.
16. To avoid burns or other fire damage, never use the saw near flammable liquids, vapors or gases.

WHENEVER SAW IS RUNNING:

17. Before actually cutting with the saw, let it run for a while. If your saw makes an unfamiliar noise or if it vibrates excessively, stop immediately. Turn the saw off. Unplug the saw. Do not restart until finding and correcting the problem.
18. Never confine the piece being cut off. Never hold it, clamp it, touch it, or use length stops against it. It must be free to move sideways. If confined, it could get wedged against the blade and thrown violently.
19. Avoid awkward hand positions where a sudden slip could cause a hand to move into the blade.
20. Let the blade reach full speed before cutting.
21. Feed the saw into the workpiece only fast enough to let the blade cut without bogging down or binding.
22. Before freeing jammed material, release switch and unplug the saw. Wait for all moving parts to stop.
23. After finishing a cut, keep holding the power-head down, release the switch, and wait for all moving parts to stop before moving your hands.

Body and Hand Position

Proper positioning of your body and hands when operating the miter saw will make cutting easier and safer. Never place hands near cutting area. Place hand at least 4" from path of blade. Hold workpiece firmly to the fence to prevent movement toward the blade. Keep hands in position until trigger has been released and the blade has completely stopped. Before making a cut, make a "dry run" with the power off so you can see the path of the blade.

WARNING: DO NOT TRY TO CUT SHORT PIECES. YOU CANNOT PROPERLY SUPPORT THE WORKPIECE AND KEEP YOUR HOLD DOWN HAND THE REQUIRED DISTANCE FROM THE BLADE.

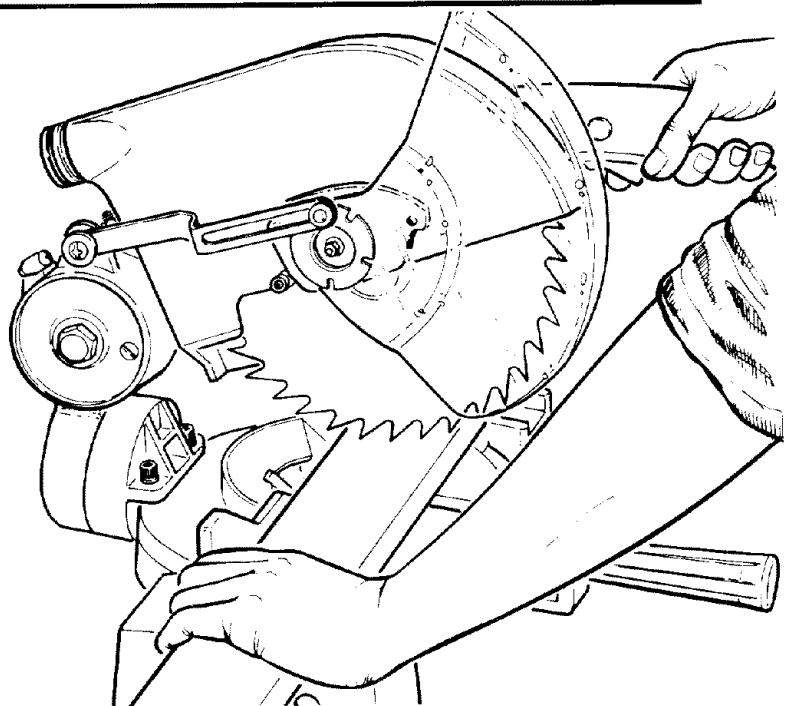

Miter Cut

When a miter cut is required, move the saw to the desired angle. Do not stand in front of the saw table. Move with the handle to the miter angle to make the cut.

NOTE: Remember to loosen the fence lock handles before changing the miter angle with the fence in the rear position.

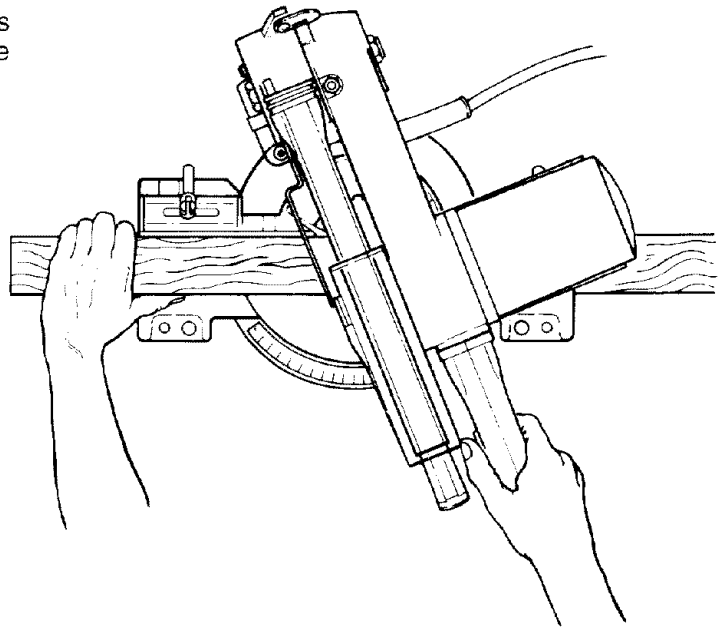

Bevel Cut

When a bevel cut is required, tilt the blade to desired bevel angle. Stand to the left side of the handle to make the cut.

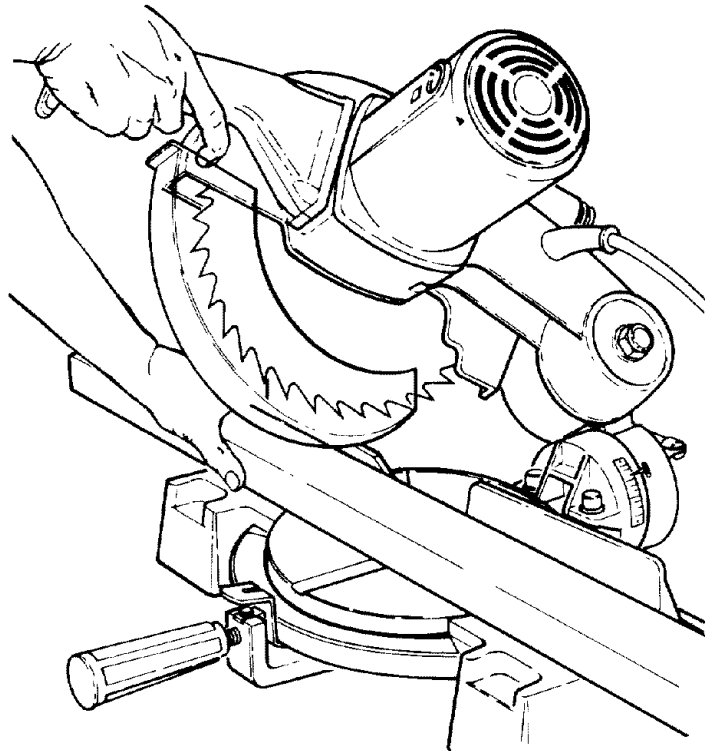

Compound Cut

When a compound cut is required, select the correct bevel and miter position. Move with the handle to the miter angle to make the cut. If the fence is in the rear position, loosen the two lock handles before changing the miter angle.

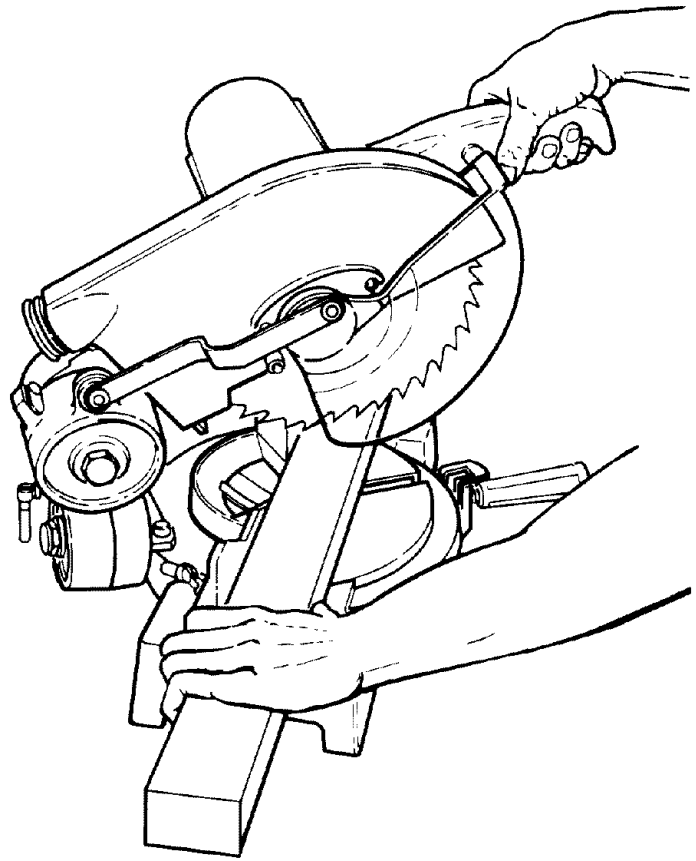

Cutting Bowed Material

Before cutting a workpiece, check to make sure it is not bowed. If it is bowed the workpiece must be positioned and cut as illustrated. Do not position workpiece incorrectly or try to cut the workpiece without the support of the fence. This will cause pinching of the workpiece on the blade. The workpiece could suddenly jump or move and your hand could hit the blade.

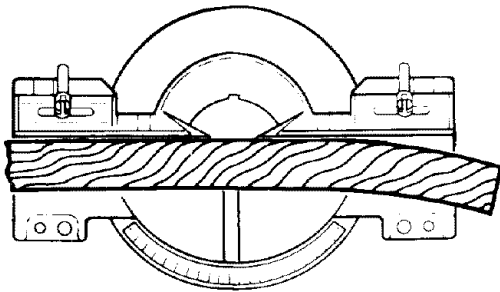

CORRECT

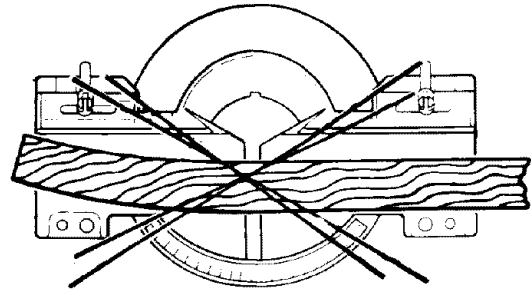

INCORRECT

Workpiece Support

Long pieces need extra supports. The supports should be placed along the workpiece so the workpiece does not sag and your hand holding the workpiece is positioned 4" or more from the blade path. The support should let the workpiece lie flat on the base and work table during the cutting operation.

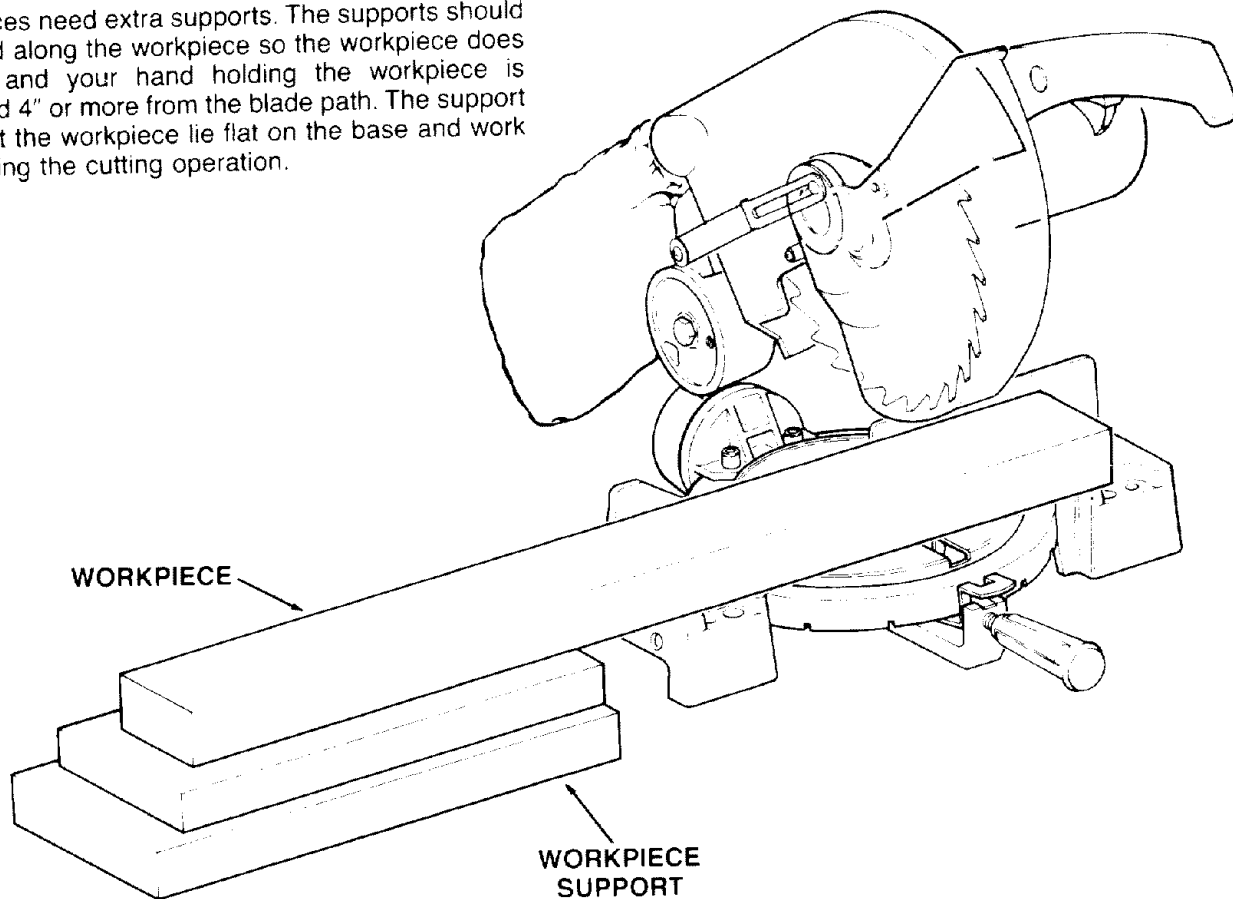

Auxiliary Fence

Certain types of molding need a fence face extension due to the size and position of the workpiece. Holes are provided in the fence to attach an auxiliary fence made of straight wood typically $\frac{1}{2}$ inch thick by 3 inches high by 20 inches long. The auxiliary fence is used with the saw in the 0° bevel position. If a bevel cut is desired, the auxiliary fence will have to be removed.

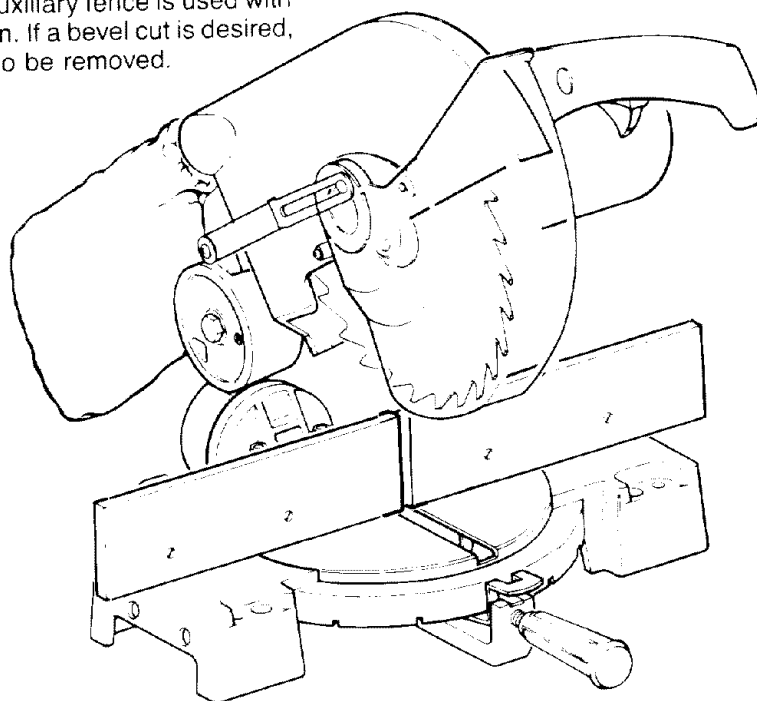

Filler Blocks for Cutting Crown Moldings

The majority of crown moldings have contact surfaces of 52° and 38° to the rear surface of the molding. When joining the face of the filler block these angles must be maintained. The following illustrations show two methods that can be used when cutting crown moldings depending on how the filler block is attached to the fence.

When the filler blocks are attached with the face of the filler blocks pointing upwards, the molding must be

placed on the table upside down.

When the filler blocks are attached to the fence with the face of the filler blocks pointing downwards, the molding must be placed on the table right side up. This is the same position as it would be when nailed between the ceiling and wall.

Make 2 filler blocks 10 inches long. Fasten blocks securely to fence. For block face pointing downward, you may need to drill new fastener holes in the fence.

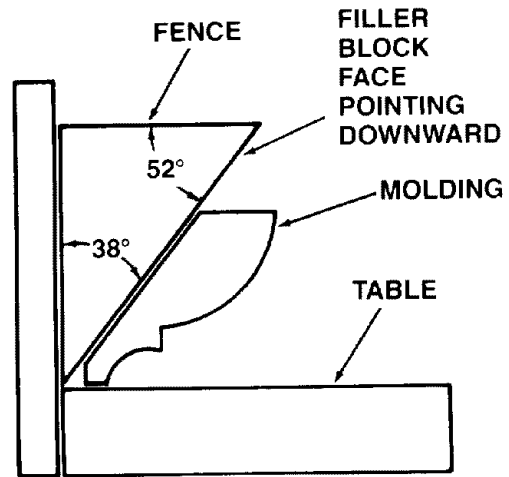
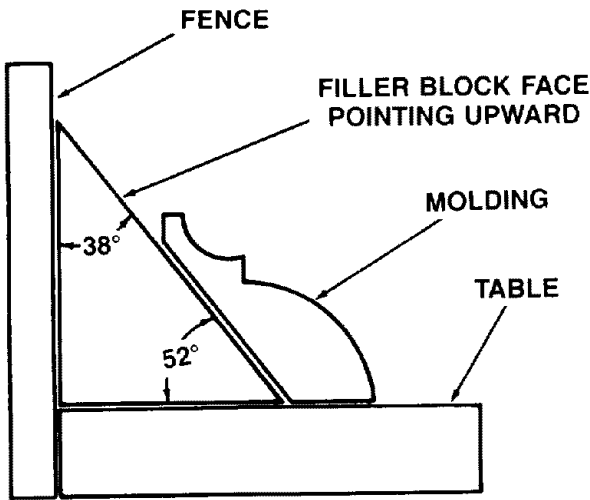

Vertical Bevel Cutting

To make a miter cut in a 2 x 4 workpiece (actual 1 $\frac{5}{8}$ " x 3 $\frac{1}{2}$ ") in the vertical position (on edge) a spacer, such as the auxiliary fence described on the previous page, is required. Fence is located in the front fence position.

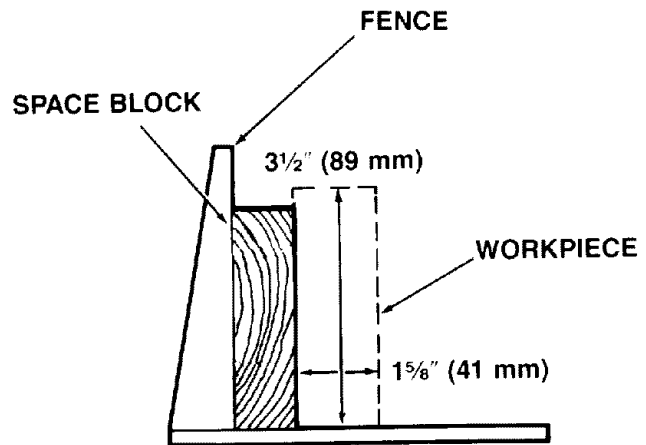

maintenance and lubrication

Maintenance

Always unplug the power cord before any maintenance check on this saw.

DANGER: Never put lubricants on the blade while it's spinning.

WARNING: TO AVOID INJURY FROM UNEXPECTED STARTING OR ELECTRICAL SHOCK, UNPLUG THE POWER CORD BEFORE WORKING ON THE SAW.

WARNING: FOR YOUR SAFETY, THIS SAW IS DOUBLE INSULATED. TO AVOID ELECTRICAL SHOCK, FIRE OR INJURY, USE ONLY PARTS IDENTICAL TO THOSE IDENTIFIED IN THE PARTS LIST. REASSEMBLE EXACTLY AS ORIGINAL ASSEMBLY TO AVOID ELECTRICAL HAZARDS.

Replacing Carbon Brushes

The carbon brushes furnished will last approximately 50 hours of running time or 10,000 on/off cycles. Replace both carbon brushes when either has less than 1/4" length of carbon remaining. To inspect or replace first unplug the saw. Then remove the black plastic cap on the side of the motor (caution, this cap is spring loaded by the brush assembly). Then pull out the brush. Repeat for the other side. To reassemble reverse the procedure. The ears on the metal end of the brush assembly go in the same hole the carbon part fits into. Tighten the cap snugly but do not overtighten.

NOTE: To reinstall the same brushes, first make sure the brushes go back in the way they came out. This will avoid a break in period that reduces performance and increases wear.

Lower Blade Guard

Do not use the saw without the lower guard. The lower blade guard is attached to the saw for protection. Should the lower guard become damaged, do not use the saw until damaged guard has been replaced. Develop a regular check to make sure the lower guard is working properly. Clean the lower guard of any dust or build up with a damp cloth.

CAUTION: Do not use solvents on the guard. They could make the plastic "cloudy" and brittle.

WARNING: WHEN CLEANING LOWER GUARD UNPLUG THE SAW FROM THE OUTLET TO AVOID UNEXPECTED START-UP.

Saw Dust

Periodically, sawdust will accumulate under the work table and base. This could cause difficulty in the movement of the work table when setting up a miter cut. Frequently blow out or vacuum up the sawdust.

WARNING: IF BLOWING SAWDUST, WEAR PROPER EYE PROTECTION TO KEEP DEBRIS FROM BLOWING INTO EYES.

Recommended Accessories

WARNING: TO AVOID INJURY FROM UNSAFE ACCESSORIES, USE ONLY ACCESSORIES SHOWN ON THE RECOMMENDED ACCESSORIES LIST IN THIS MANUAL.

Prohibited Accessories—The use of any cutting tool except 10" saw blades which meet the requirement under recommended accessories is prohibited. Do not use accessories such as shaper cutters or dado sets. Ferrous metal (metal with iron in it) cutting and the use of abrasive wheels are prohibited. See **DANGER NOTE** (BASIC SAW OPERATIONS) if planning to saw non-ferrous metal.

Leg Sets 9-22244
9-22246

Carbide-Tipped Blades:

Trim Saw See Catalog
Cut-Off See Catalog
Combination See Catalog
Plywood/Particle Board See Catalog

Non-Carbide Tipped Blades:

Cross Cut/Plywood See Catalog
Combination See Catalog

Basic Blade Requirements

10" Diameter
Blades marked for 5,500 RPM or higher.
5/8" Arbor Hole

Lubrication

All the motor bearings in this tool are lubricated with a sufficient amount of high grade lubricant for the life of the unit under normal operating conditions, therefore, no further lubrication is required. (See below.)

Infrequent Lubrication as Required:

1. Lubrication of arm pivot for free movement.
 - a. By loosening nut and applying oil to washer and to contact face (minor).
 - b. Dis-assembly means required to grease pivot bolt and contact faces (major).

NOTE: Disassembly should be done by an authorized service technician. Removal of the upper guard and the bolt stop is necessary before pivot can be disassembled. Pay close attention to the spring-end positions in the castings.....mark with chalk to avoid later confusion.

2. Lubrication of mechanism which pivots lower guard: Use light household oil (sewing machine oil) on metal-to-metal or metal-to-plastic guard contact areas as required for smooth, quiet operation. Avoid excess oil, to which sawdust will cling.



TROUBLE SHOOTING GUIDE - MOTOR

PROBLEM	PROBABLE CAUSE	SUGGESTED CORRECTIVE ACTION
Brake does not stop blade within 2-5 seconds.	<ol style="list-style-type: none"> 1. Brushes not seated or lightly sticking. 2. Motor brake winding—overheated from use of not-recommended accessory or rapid on/off cycling. 3. Arbor screw loose. 4. Other. 	<ul style="list-style-type: none"> — Inspect/clean/replace brushes (see maintenance section). — Use a recommended blade. — Let cool down. — Retighten — Authorized service. Check motor brake winding.
Motor does not start.	<ol style="list-style-type: none"> 1. Fuse. 2. Brushes worn. 3. Other. 	<ul style="list-style-type: none"> — 15-Amp time delay fuse, or CKT. breaker. — See "Maintenance," page 21. — Authorized service.
Brush sparking when switch released.	<ol style="list-style-type: none"> 1. Normal—automatic brake working properly. 	

TROUBLE SHOOTING GUIDE - GENERAL

PROBLEM	PROBABLE CAUSE	SUGGESTED CORRECTIVE ACTION
Blade hits table.	<ol style="list-style-type: none"> 1. Misalignment. 2. Damaged depth stop. 	<ul style="list-style-type: none"> — See Assembly and Alignment, page 10. — Get authorized Sears Service.
Angle of cut not accurate.	<ol style="list-style-type: none"> 1. Misalignment. 	<ul style="list-style-type: none"> — See Assembly and Alignment, page 10.
Can't move miter adjustment.	<ol style="list-style-type: none"> 1. Fence in rear position and clamp tight. 2. Sawdust under table. 	<ul style="list-style-type: none"> — Loosen fence clamps. Retighten before starting next cut. — Vacuum or blow out dust. WEAR EYE PROTECTION
Power-head wobbles.	<ol style="list-style-type: none"> 1. Loose pivot points. 	<ul style="list-style-type: none"> — See Assembly and Alignment, Step 4, page 12.
Power-head won't fully rise.	<ol style="list-style-type: none"> 1. Pivot misadjustment. 2. Part failure. 3. Pivot spring not replaced properly after service. 	<ul style="list-style-type: none"> — See Assembly and Alignment, Step 4, page 12. — Get authorized Sears Service. — Get authorized Sears Service.
Blade binds, jams, burns wood.	<ol style="list-style-type: none"> 1. Improper operation. 2. Dull blade. 3. Improper blade 4. Warped blade. 	<ul style="list-style-type: none"> — See Basic Saw Operation, page 16. — Replace or sharpen blade. — Replace with 10" diameter blade designed for the material being cut. — Replace blade.
Tool vibrates or shakes.	<ol style="list-style-type: none"> 1. Saw blade not round. 2. Saw blade damaged. 3. Saw blade loose. 4. Other. 	<ul style="list-style-type: none"> — Replace blade. — Replace blade. — Tighten arbor screw. — Get authorized Sears Service.



PARTS LIST FOR CRAFTSMAN 10" COMPOUND MITER SAW
MODEL NO. 113.234650

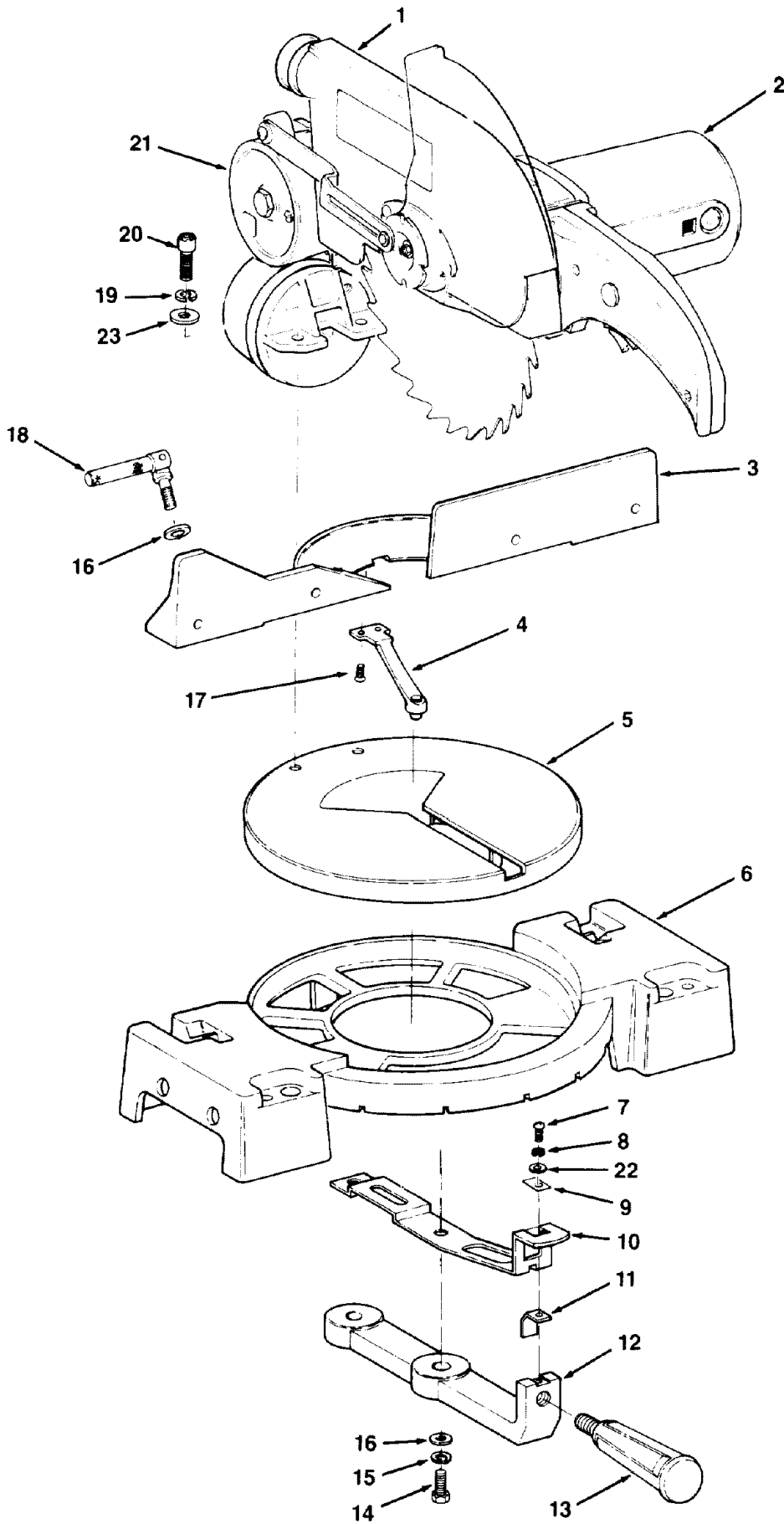

repair parts

PARTS LIST FOR CRAFTSMAN 10" COMPOUND MITER SAW MODEL NO. 113.234650

Always order by Part Number—Not by Key Number

FIGURE 1

Key No.	Part No.	Description	Key No.	Part No.	Description
1	—	Blade Guard Asm. (see Fig. 4)	13	816669	Handle-Miter
2	—	Motor Asm. (see Fig. 2)	14	STD523108	*Bolt-Hex HD. 5/16-18 x 7/8
3	816688	Fence	15	STD551131	*Lockwasher 5/16
4	816810	Arm-Fence	16	STD551031	*Washer 11/32 x 11/16 x 1/16
5	816673	Table	17	809727-2	Screw Flat HD. Type "T" 8-32 x 3/8
6	816678	Base (Includes Scale)	18	816863-1	Clamp-Bolt
7	STD510802	* Screw Pan HD. 8-32 x 5/16	19	STD551137	*Lockwasher 3/8
8	STD551108	* Lockwasher #8	20	60032	Screw Soc HD. Cap 3/8-16 x 1
9	816716	Indicator-Miter	21	—	Pivot Asm. (see Fig. 3)
10	816691	Spring-Index	22	818042	Washer 4 x 10 x 0.8mm
11	816690	Plate-Clamp	23	817182	Washer 10 x 19 x 1.8mm
12	816685	Arm-Miter			

*Standard Hardware Item—May Be Purchased Locally.

repair parts

PARTS LIST FOR CRAFTSMAN 10" COMPOUND MITER SAW MODEL NO. 113.234650

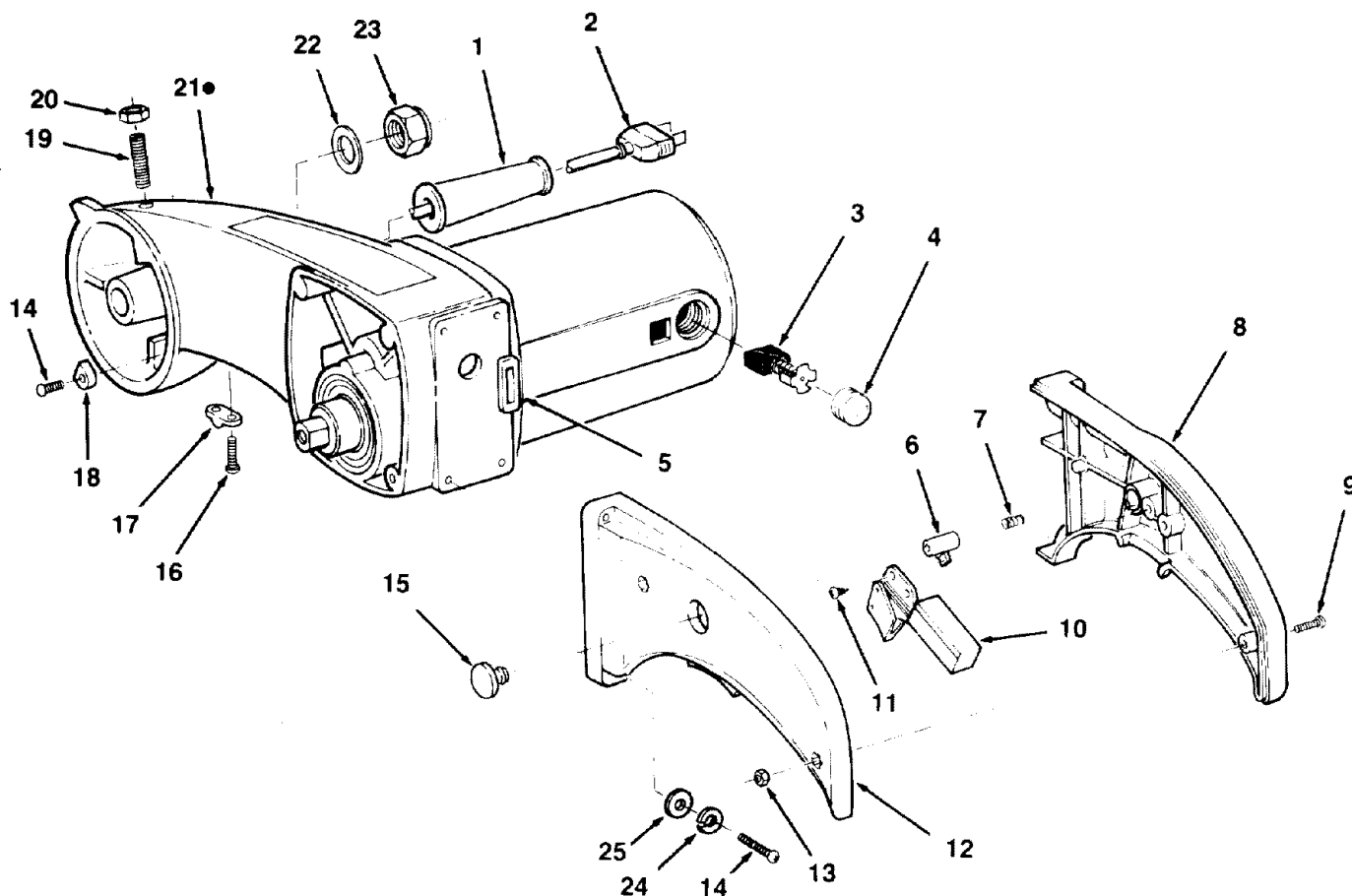

Always order by Part Number—Not by Key Number

FIGURE 2—ARM AND MOTOR ASSEMBLY

WARNING: For your safety, this miter saw is specially insulated. To avoid electrical shock, fire or injury, use only parts identical to those identified in the parts list. Reassemble exactly as originally assembled.

Key No.	Part No.	Description
1	816667	Guard-Cord
2	816704	●Cord w/Plug
3	816768	Brush
4	816770	Cover-Brush
5	816740	Protector-Wire
6	816697	Lock-Switch
7	816696	‡Spring-Switch Lock
8	816679	Handle-R.H.
9	46-57466-3	*Screw Pan HD. M4 x 20
10	816700	●Switch
11	817143	Screw Pan HD. TY "AB" M4 x 12
12	816680	Handle - L.H.
13	56-100002	*Nut Hex M4 x 0.7
14	816755	Screw Pan HD. M5 x 20

Key No.	Part No.	Description
15	816701	Button-Switch
16	816743	Screw Pan HD. M4 x 15
17	816725	Clamp-Cord
18	816668	Cushion
19	816698	Screw-Set Slotted M10 x 1.5
20	56-100007	*Nut Hex M10 x 1.5
21	816689-1	●Motor & Arm Asm. (Includes Keys 1,2,3,4,5,16,17)
22	60047	Washer .630 x 1 x 1/32
23	816723	Nut Lock M16
24	STD551110	*Lockwasher #10
25	818043	Washer .350 x .170 x .03
—	SP5229	Owner's Manual (Not Illus.)

● Any attempt to repair or replace electrical parts on this unit may create a **HAZARD** unless repair is done by a qualified service technician. Repair service is available at your nearest Sears Store.

*Standard Hardware Item—May Be Purchased Locally.

26 ‡See Mechanical Assembly Caution on page 29.



repair parts

PARTS LIST FOR CRAFTSMAN 10" COMPOUND MITER SAW MODEL NO. 113.234650

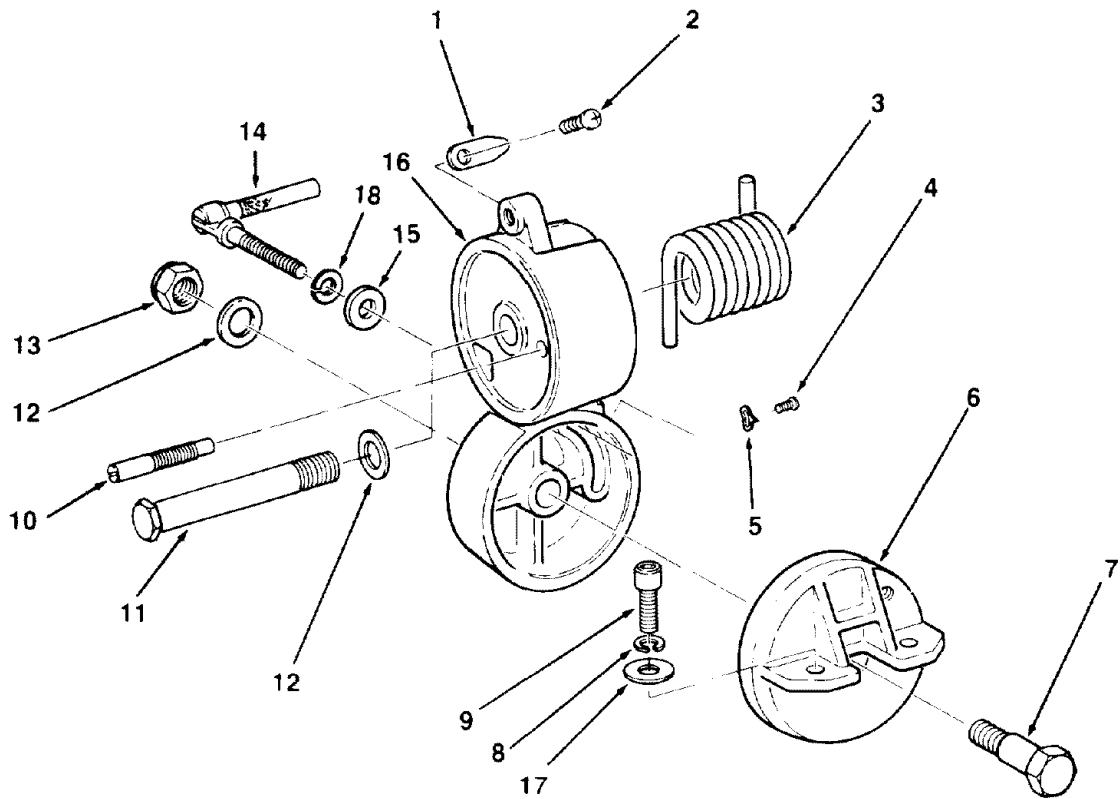

Always order by Part Number—Not by Key Number

FIGURE 3—PIVOT ASSEMBLY

Key No.	Part No.	Description
1	816664	Plate-Lock
2	816674	Screw Pan HD. Shoulder M6
3	816671	‡Spring-Torsion
4	STD510602	*Screw Pan HD. 6-32 x 1/4
5	816686	Indicator-Bevel
6	816714	Pivot-Support
7	816722	Bolt-Bevel
8	STD551137	*Lockwasher 3/8
9	60032	Screw Soc HD. Cap 3/8-16 x 1

Key No.	Part No.	Description
10	816666	Bolt-Stop
11	816721	Bolt-Pivot
12	60047	Washer .630 x 1 x 1/32
13	816723	Nut Lock M16
14	816863	Clamp-Bolt
15	STD551031	*Washer 11/32 x 11/16 x 1/16
16	816676	Pivot
17	817182	Washer 10 x 19 x 1.8
18	STD551131	*Lockwasher 5/16

*Standard Hardware Item—May Be Purchased Locally.

‡See Mechanical Assembly Caution on page 29.

repair parts

PARTS LIST FOR CRAFTSMAN 10" COMPOUND MITER SAW MODEL NO. 113.234650

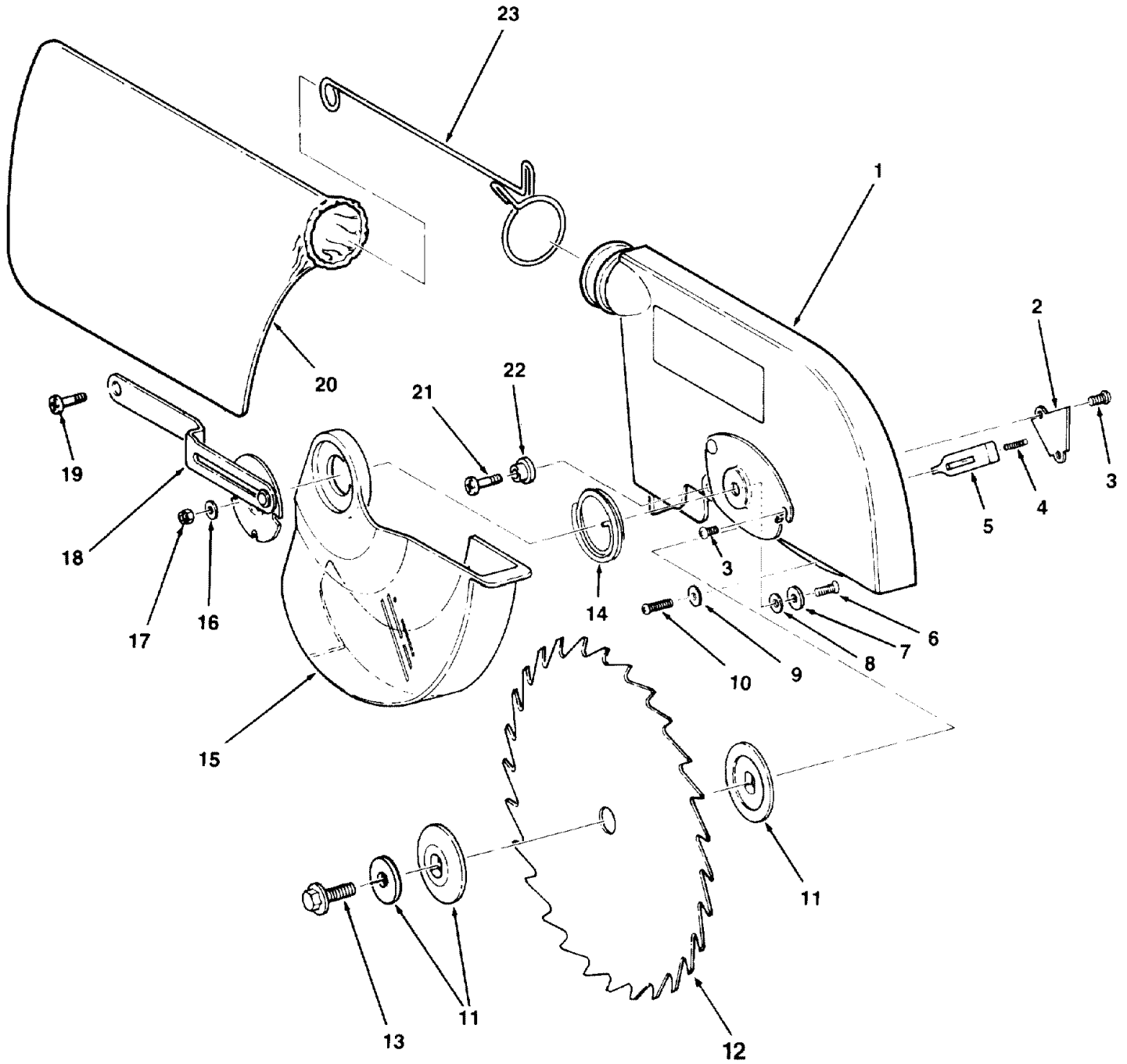

repair parts

PARTS LIST FOR CRAFTSMAN 10" COMPOUND MITER SAW MODEL NO. 113.234650

Always order by Part Number—Not by Key Number

FIGURE 4. Blade & Blade Guard Asm.‡

Key No.	Part No.	Description	Key No.	Part No.	Description
1	507758	Guard Asm.	13	816703	Scr. Hex Washer HD. L.H. M8 x 1.25
2	816706	Plate-Retainer	14	816677	‡ Spring-Guard
3	STD511103	* Screw Pan HD. 10-32 x 3/8	15	816711	‡ Guard-Lower
4	816708	Spring	16	60041	Washer 13/64 x 1/2 x 1/32
5	816707	Lock-Spindle	17	40465	Nut Lock 10-32
6	813094-3	Screw Hex HD. 10-32 x 3/8	18	507757	Lever Asm.-Actuator
7	STD551010	* Washer 13/64 x 1/2 x 1/16	19	817144	Screw-Shoulder 1/4-20 x 1/2
8	816849-1	Spacer 7/32 x 5/16 x 9/64	20	816811	Bag-Dust
9	46-58494-3	Lockwasher 5mm	21	817145	Screw-Shoulder 10-32 x 13/16
10	816755-2	Screw Pan HD. M5 x 15	22	816818	Sleeve-Rubber
11	507759	Collar-Blade Set (Includes Key #13)	23	816812	Clamp-Bag
12	818078	10-in. Carbide Tip Saw Blade			

*Standard Hardware Item—May Be Purchased Locally.

‡See following Mechanical Assembly Caution.

CAUTION: MECHANICAL ASSEMBLY, TO QUALIFIED SERVICE TECHNICIAN.

1. Wear approved eye protection when working with coil springs including spring, switch lock 816696.
2. Incorrect re-assembly of torsion spring 816671 can cause an unsafe condition because cutting head fails to rise fully to stop, or because spring fails through over-stress.
3. Improper re-assembly of mechanisms controlling movement of lower guard 816711 can cause an unsafe condition because guard fails to operate freely as cutting head is moved up and down; or because, with cutting head up, manually rotated guard is not (lightly) restored to the closed position by guard spring 816677.

1/4-20 SHOULDER SCREW



SEARS

**owner's
manual**

SERVICE

**MODEL NO.
113.234650**

**10" CONTRACTOR
MITER SAW**

**HOW TO ORDER
REPAIR PARTS**

10-INCH CONTRACTOR MITER SAW

Now that you have purchased your 10-inch Contractor Miter Saw, should a need ever exist for repair parts or service, simply contact any Sears Service Center and most Sears, Roebuck and Co. stores. Be sure to provide all pertinent facts when you call or visit.

The model number of your 10-inch Contractor Miter Saw will be found on a plate attached to your saw, at the side of the Miter Saw arm.

WHEN ORDERING REPAIR PARTS, ALWAYS GIVE THE FOLLOWING INFORMATION:

PART NUMBER

PART DESCRIPTION

**MODEL NUMBER
113.234650**

**NAME OF ITEM
10" CONTRACTOR MITER SAW**

All parts listed may be ordered from any Sears Service Center and most Sears stores. If the parts you need are not stocked locally, your order will be electronically transmitted to a Sears Repair Parts Distribution Center for handling.

Sold by SEARS, ROEBUCK AND CO., Chicago, IL 60684 U.S.A.

Part No. SP5229

Form No. SP5229-2

Printed in Taiwan 9/89