

SONANCE

PROFESSIONAL SERIES

HIGH OUTPUT IN-CEILING LOUDSPEAKER

PS-C85RTBF AND PS-C85BB | BAFFLE AND BACK BOX

MANUAL

PROFESSIONAL SERIES HIGH OUTPUT IN-CEILING LOUDSPEAKER

PS-C85RTBF and PS-C85BB

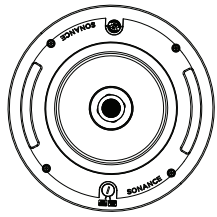

PS-C85RTBF
BAFFLE

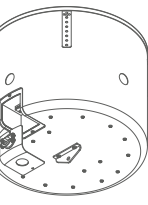
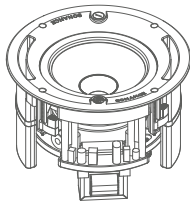

PS-C85BB
BACK BOX

TABLE OF CONTENTS

- 2 Box and Contents
- 3 Product Features
- 4 Amplifier Selection
- 4 Wire Selection
 - 70V/100V System
 - 8 ohm System
- 4 Loudspeaker Placement
- 4 Grille Painting
- 5 Assembly and Installation
- 9 Technical Specifications
- 10 Certifications and Safety Agency
- 10 Technical Assistance and Service
- 11 Warranty

BOX CONTENTS

IN-CEILING LOUDSPEAKER BAFFLE

- (1) PS-C85RTBF
- (1) Round White Loudspeaker Grille
(Black Grille Optional)
- (1) Variable Dispersion Horn
- (1) Collar Removal Tool

IN-CEILING LOUDSPEAKER BACK BOX

- (1) PS-C85BB
- (1) Cutout Template
- (1) Euroblock Wire Connector
- (1) Cable & Conduit Clamp

IMPORTANT SAFETY INSTRUCTIONS

This product is intended to be installed by professional AV integrators and installers only. This product manual is intended to serve as a general guideline for most applications. It is the installer's responsibility to ensure this product is installed in accordance with local building codes and regulations. Consult a local authority for specific requirements, regulations, and building codes of the jurisdiction in which this product is to be installed.

READ THIS DOCUMENT IN ITS ENTIRETY BEFORE ATTEMPTING USE

1. Read these instructions.
2. Keep these instructions.
3. Heed all warnings.
4. Follow all instructions.
5. Clean only with a dry cloth.
6. Do not block any ventilation openings. Install in accordance with the manufacturer's instructions.
7. Do not install near a heat source such as radiators, heat registers, stoves, fireplaces, or other apparatus (including amplifiers) that produce heat.
8. Only use attachments/accessories specified by Sonance.
9. Refer all servicing to qualified service personnel.

PRODUCT DESCRIPTION

From Sonance, the company that created the architectural audio category, comes a range of professional loudspeakers that set a new benchmark in sound quality and aesthetics for commercial environments. Sonance Professional Series High Output is a range of 70V/100V or low impedance and tap selectable loudspeakers available as in-ceiling, surface mount, or pendant models. These High Output models achieve elevated SPL levels with the ability to field-configure each loudspeaker for wide or narrow directivity. Their shared voicing across form factors ensure seamless sonic integration when deployed together throughout professional and commercial spaces. The In-Ceiling Loudspeakers feature a one-piece, bezel-less grille that is magnetically secured and allows for a one-step painting process to simplify installation and minimize visual distraction. The optional square grille adapter allows the loudspeakers to match the aesthetic of square down lights and HVAC grilles. Sealed metal enclosures, integrated cable and conduit clamping, seismic attachment and connector cover allow them to be installed in commercial environments where UL 1480A and UL 2043 are required by code.



Scan QR code for additional information and resources. For technical support call 949.492.7777 or visit www.sonance.com/professionalseries

PRODUCT FEATURES

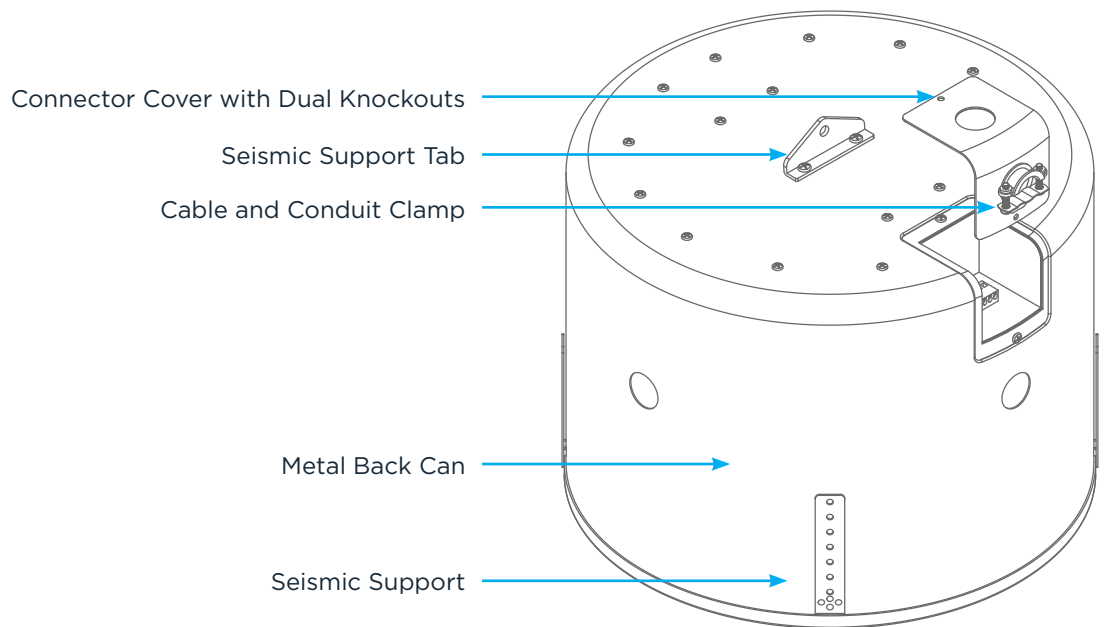
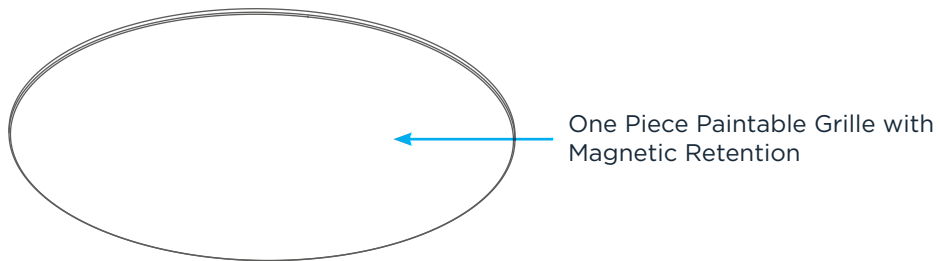
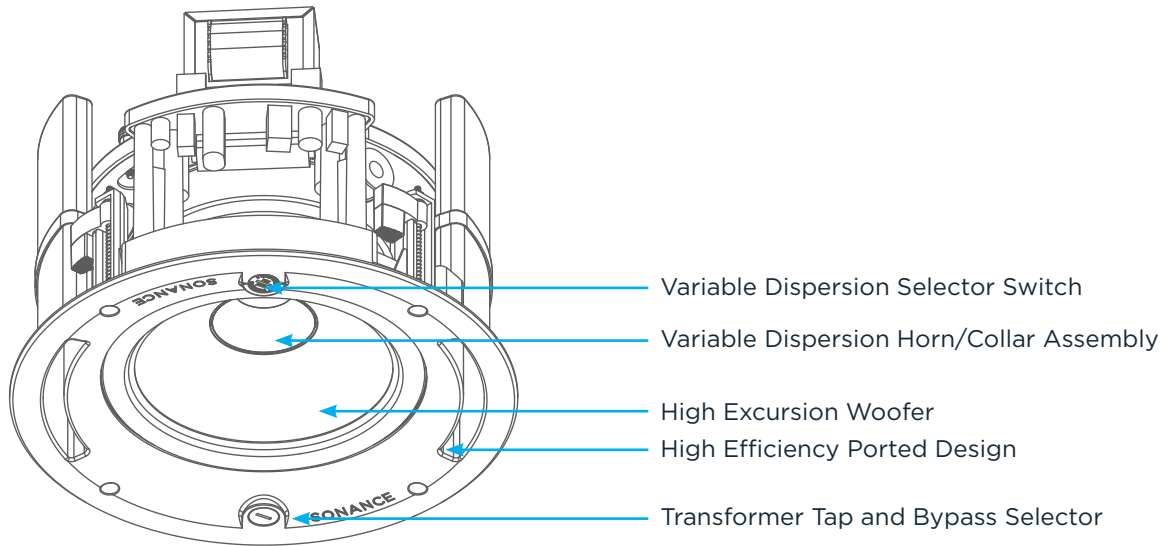

AMPLIFIER SELECTION

When choosing an amplifier, the maximum number of loudspeakers and the output level of each loudspeaker must be known. The sum of the tap settings should never exceed 80% of the amplifier's rated output. For example, if there are five loudspeakers and the taps are set at 15 watts, the load would be 75 watts (5 x 15 watts = 75 watts). To arrive at the needed power for this number of loudspeakers, simply divide the total load by 0.8. In this case, $75/0.8 = 93.75$ watts. Therefore, a standard 100 watt amp would safely drive this load. To calculate the amount of usable power an amp offers, simply multiply the rated output by 0.8, i.e., $100 \text{ watts} \times 0.8 = 80 \text{ watts}$.

WIRE SELECTION

WIRE GAUGE - 70V/100V SYSTEM

The most common wire used on commercial 70 volt systems is 18 AWG, 2 conductor, stranded, and jacketed without a shield. The wire starts at the amplifier location and is paralleled at each loudspeaker location. Wire length using 18 AWG is appropriate up to 700ft with a 100 watt load. If you double the load (sum of your tap settings), you will reduce the footage by half, to 350ft. Conversely, if you halve the load, you may double the acceptable wire length, i.e., a 50 watt load is safe over 1,400ft of 18 AWG. Stepping up to 16 AWG wire extends the allowable run length by approximately 35%. For example, a 100 watt load can go 700ft on 18 AWG; the same load may be placed on 1,100ft of 16 AWG.

WIRE GAUGE - 8 OHM SYSTEM

When using Sonance Professional Series loudspeakers in an 8 ohm system the total wire resistance should be less than 10% of the loudspeaker impedance. The loudspeakers are nominally 8 ohms impedance, so your total wire resistance should be no more than 0.8 ohms. In simple terms, the extra resistance from the wire will have a very negative affect on the sound quality of the loudspeaker. The sound can be less dynamic, definition of bass frequencies can be reduced, and in extreme cases, the high frequencies can be attenuated. Amplifier power is also wasted in the wire, reducing the maximum output level of the system. Please refer to the following chart (see Figure 1) when deciding on the appropriate wire gauge for your installation.

WIRE RESISTANCE IN OHMS VS. LENGTH OF CABLE RUN						
Distance in Feet	50'	100'	150'	200'	250'	300'
20 AWG	0.86	1.73	2.59	3.45	4.32	5.18
18 AWG	0.65	1.3	1.94	2.59	3.24	3.89
16 AWG	0.43	0.85	1.28	1.71	2.14	2.56
14 AWG	0.27	0.53	0.81	1.08	1.35	1.62
12 AWG	0.17	0.34	0.51	0.68	0.85	1.02

Figure 1: Wire Resistance

LOUDSPEAKER PLACEMENT

Sonance Professional Series Loudspeakers possess extremely smooth and predictable off-axis frequency response. The chart below (see Figure 2) shows how far apart the loudspeakers can be placed in a distributed audio system. The calculations are based on +/-45 degrees of coverage from the loudspeaker, and listener ear heights of 62" for standing and 40" for seated.

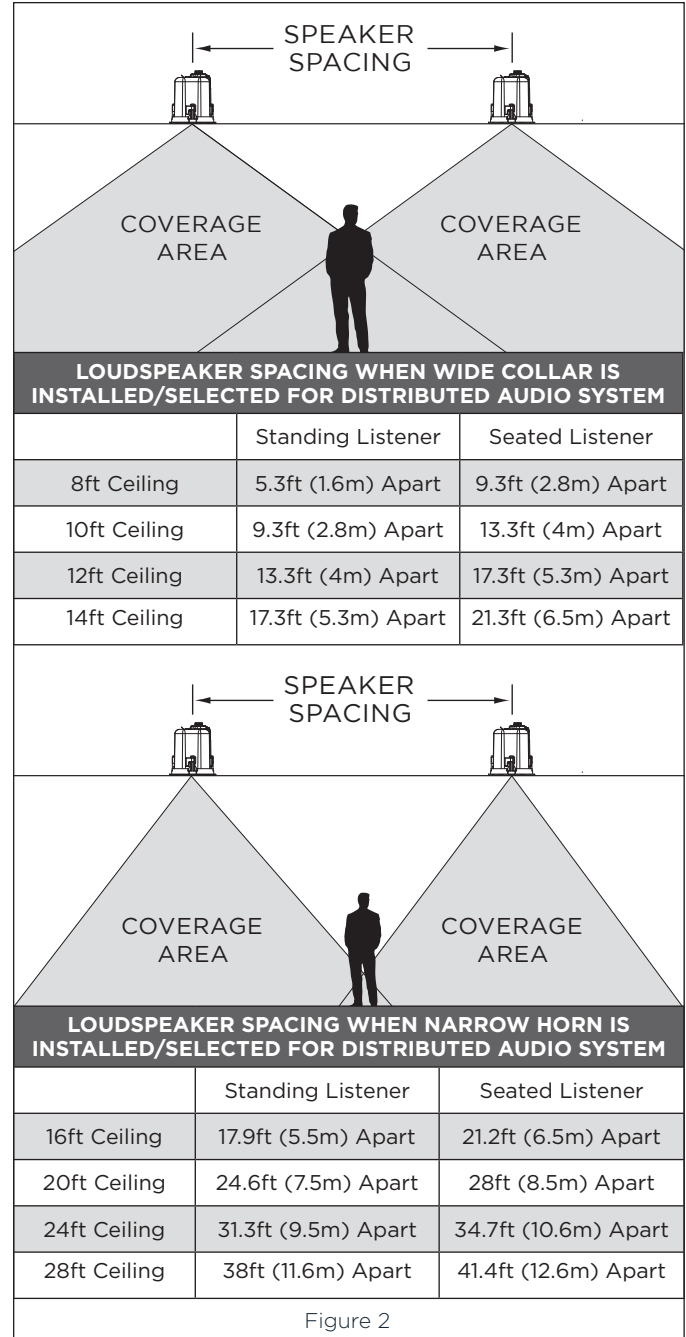

GRILLE PAINTING

Sonance PS In-Ceiling Loudspeaker grilles completely cover the exposed loudspeaker frame, so only the grilles (not the loudspeakers themselves) require painting.

IMPORTANT: Mask the front flange and baffle of the loudspeaker before painting the wall or ceiling (see Figure 3).

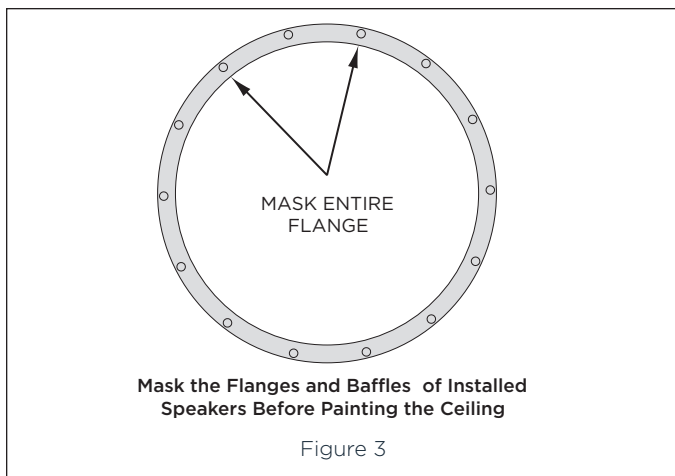

PREPARING THE GRILLES FOR PAINTING

Carefully remove the scrim cloth from the underside of the grille. The scrim cloth is held in place with a light tacking glue. Use a heating agent such as a heat gun or hair dryer to soften the glue and carefully remove the cloth. Since, you will need to replace it when you're done painting the grille, be careful not to deform the cloth's shape while removing it. Deformation will make it very difficult to properly replace the cloth on the grille. Remove any adhesive residue from the back of the grille before beginning painting.

PAINTING THE GRILLES

1. Prime the grille with a metal primer/bonder in a spray can. Carefully follow the manufacturer's directions on the can.
2. We recommend using water-based latex paint. Thin the paint with a proper thinning agent to a ratio of 1:1 paint-to-thinner, and strain it through a standard mesh strainer to remove any lumps.

IMPORTANT: Due to its increased durability, oil-based paint should be considered for Professional Series Loudspeakers that are installed outdoors.

3. Use a small touch-up gun or cap-spray gun with a #3 tip for painting.
 - Set the nozzle with a medium to wide fan.
 - Set the pressure regulator to 60psi.
 - Lightly spray the front of the grille in three quick strokes from approximately 10" away.
 - Let the paint set for a minute, then turn the grille 90 degrees and lightly spray the grille again in three quick strokes. Repeat this step until all four sides of the grille have been evenly painted.
4. While the paint is still wet, inspect the grille and make sure that excess paint has not collected underneath the grille frame, and that none of the grille perforations are filled with paint. If any are, use compressed air to blow the paint out of the perforations.

IMPORTANT: If any grille perforations are plugged with paint after the paint has dried, use a straight pin or sewing needle to carefully remove the paint.

5. Once the paint has thoroughly dried, replace the scrim cloth on the back of the grille and mount the grille on the loudspeaker.

BEFORE YOU BEGIN

Install the appropriate dispersion assembly into the PS-C85RTBF loudspeaker baffle. Sonance Professional Series High Output Loudspeakers feature a magnetic interchangeable collar/horn assembly that can be swapped out to achieve the desired coverage. For wide coverage applications, leave the collar assembly in place (comes installed as default). For narrow coverage applications, remove the collar and install the horn.

The selector located on the baffle must be assigned to the appropriate position to match the installed assembly (see Page 7 for more about dispersion assembly selection).

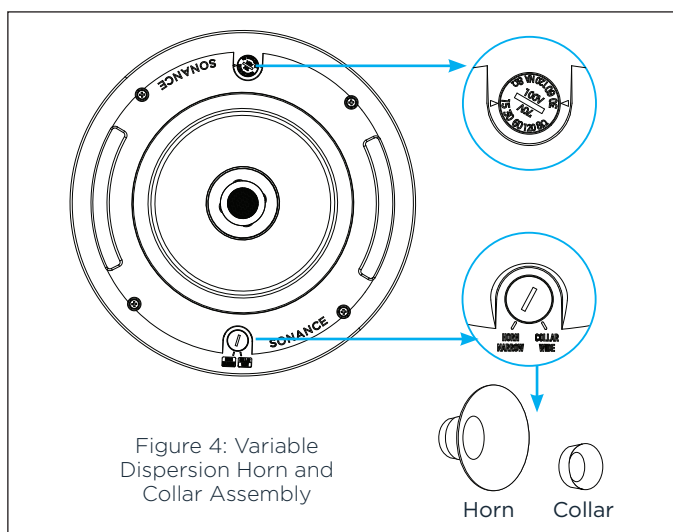

SAFETY PRECAUTION: Attaching the seismic tab of the PS-C85BB back box to a support line is highly recommended for additional safety.

1. Run the speaker wire from the amplifier to the back box location.
2. Connect the wires to the Euroblock wire connector (included with PS-C85BB Loudspeaker Back Box). Strip approximately 0.1875" (5mm) of the insulation off each wire. Insert the wire into the correct square opening on the connector. Use a small flat head screwdriver to tighten the corresponding screw to secure the wire (see Figures 5 and 6).



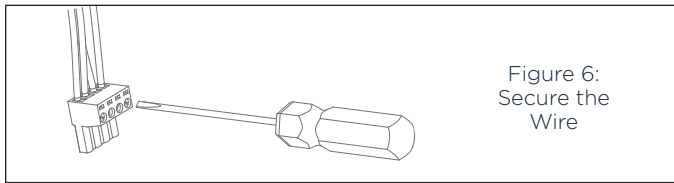

Figure 6:
Secure the
Wire

- When using multiple loudspeakers you can connect the loudspeakers either in parallel or in the loop through method as shown below (see Fig 7 and 8).

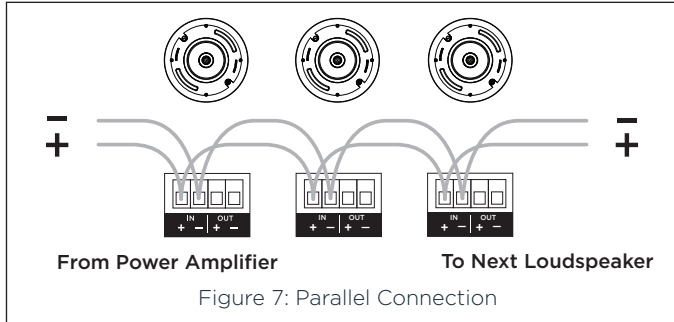

Figure 7: Parallel Connection

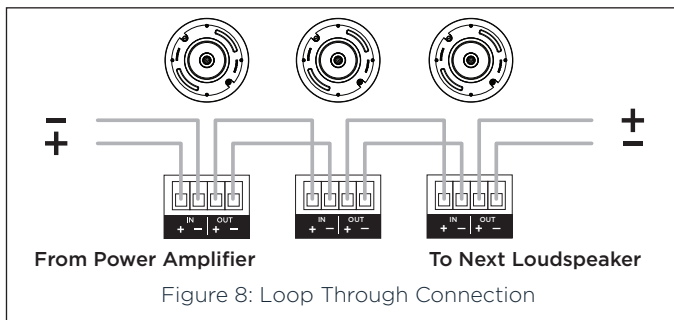

Figure 8: Loop Through Connection

- Once all the wires are terminated. Plug the Euroblock Connector into the back of the PS-C85BB loudspeaker back box (see Figure 9).

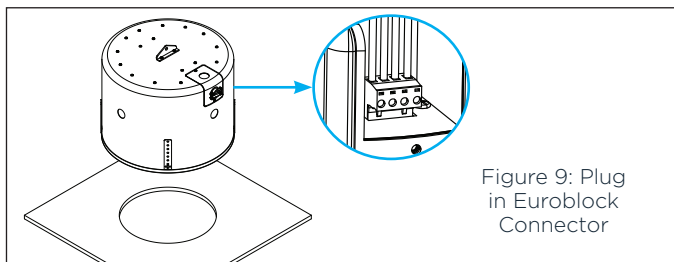

Figure 9:
Plug
in Euroblock
Connector

- Route the wires through the Strain Relief Fitting on the back of the back box. Tighten the screws on the strain relief to clamp the wires. Make sure not to over-tighten the screws and damage the wire (see Figure 10).

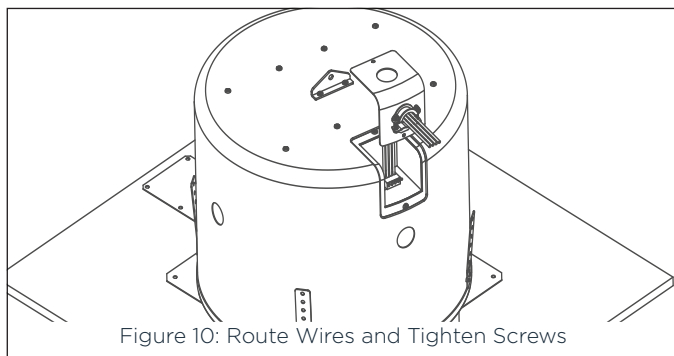

Figure 10: Route Wires and Tighten Screws

PS-C85RTBF BAFFLE INSTALLATION

NOTE: If square grilles are being used, the adapter frame must be installed at this time.

- Once drywall is installed, the PS-C85RTBF loudspeaker baffle assembly can be inserted into the back box opening. First, join the wiring harness between the back box and the speaker baffle. Connect the stripped wire to the spring loaded wire terminals on the back of the speaker baffle, connecting the black wire to the black terminal and the red wire to the red terminal (see Figure 11).

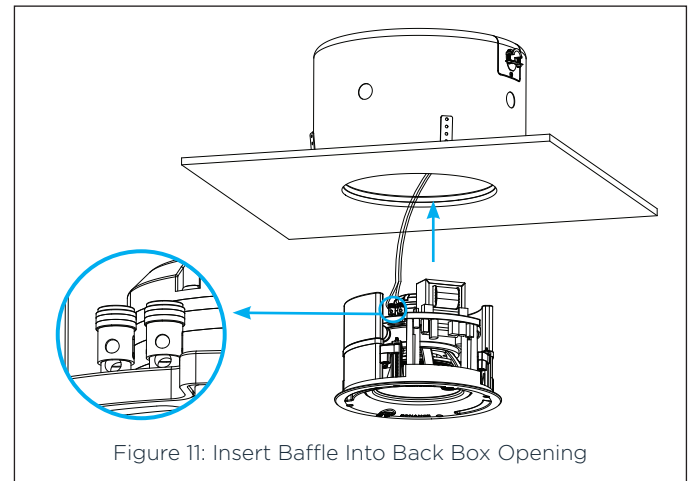

Figure 11: Insert Baffle Into Back Box Opening

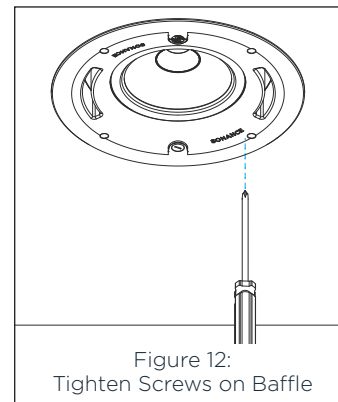

Figure 12:
Tighten Screws on Baffle

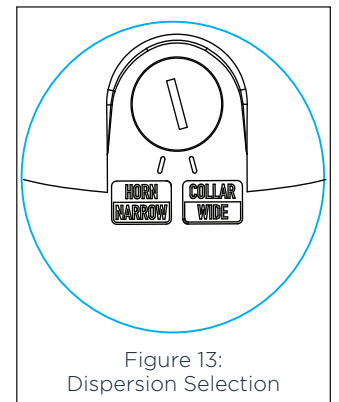

Figure 13:
Dispersion Selection

- Make sure the Roto-Lock Clamps are in the full clockwise position so that all the clamps are tucked into the baffle to fit into the back box opening. Insert the loudspeaker baffle into the opening. Use a screw driver or drill on lowest setting to secure the baffle to the back box via the four dog ear screws around the baffle (see Figure 12).
- Install the appropriate dispersion assembly. Sonance Professional Series High Output loudspeakers feature a magnetic interchangeable collar/horn assembly that can be swapped out to achieve the desired dispersion. For wide dispersion applications, leave the collar assembly in place (comes installed as default). For narrow dispersion applications, remove the collar and install the horn. **The selector located on the baffle must be assigned to the appropriate position to match the installed assembly (see Figure 13).**

WIDE/COLLAR

This Professional Series High Output loudspeaker ships with the collar installed.

- For applications requiring wide loudspeaker dispersion, no assembly changes are needed.
- Ensure the selector on the front baffle is in the “WIDE/COLLAR” position.

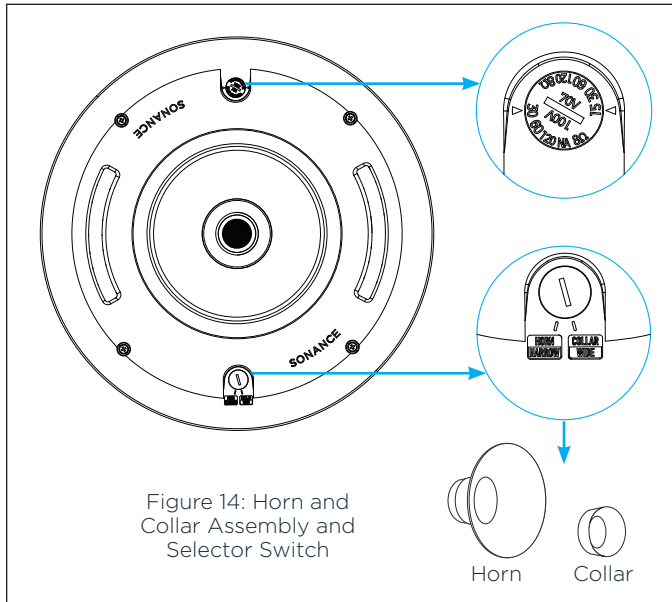

NARROW/HORN

For applications requiring narrow loudspeaker dispersion, the collar will need to be removed for the horn to be installed. Sonance includes a collar claw removal tool for easy collar removal.

- Identify the four slots on the collar marked by blue rings.
- Align the collar removal tool with two of the slots and snap the claw into place.

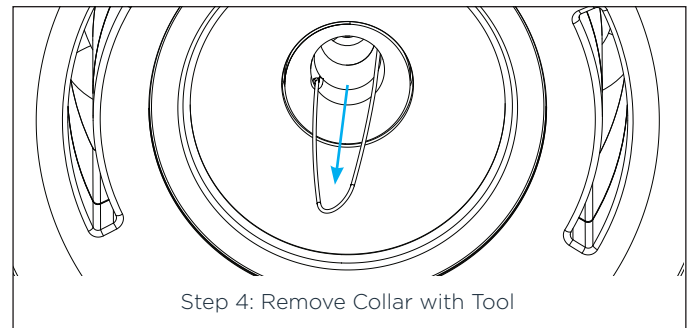
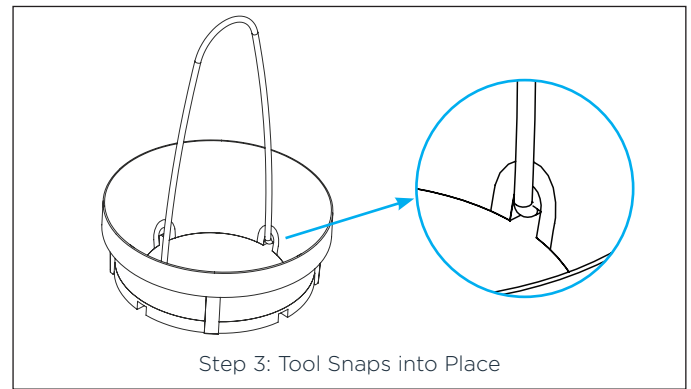
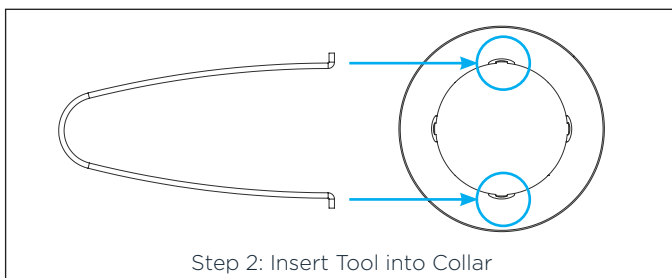
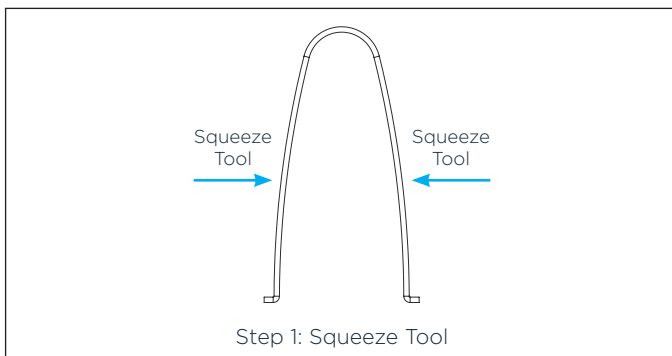

- Pull up to remove the collar. The collar can be discarded unless the installer plans to relocate the loudspeaker in the future, in which case the collar can be reserved.
- The horn attaches magnetically. Align the horn into position and it will snap into place.
- Switch the selector on the front baffle to the “NARROW/HORN” position.

NOTE: If removal of the horn is required, no tool is needed. The horn attaches magnetically and can be installed and removed by hand.

SETTING THE TRANSFORMER TAP

9. Adjust the transformer tap to the appropriate setting. Sonance Professional Series High Output loudspeakers are factory set for maximum output when used with a Sonance DSP 2-750 MKIII or another 70V/100V amplifier. No additional work is necessary if the loudspeakers are operating in 70V or 100V and can run at their full volume capacity.

Applications for changing the tap switch from factory default:

- Loudspeakers are to be installed in sensitive areas and need to be “tapped down” for lower volume.
- More loudspeakers are needed to be added to a 70V/100V amplifier already operating at full capacity.
- A small zone is to be driven by an 8 ohm amplifier.

8 OHM SETTINGS

Aligning the values on the dial with the arrow indicators on either side to the 8 ohm setting bypasses the internal transformer for operation with low impedance amplifiers.

70V TAP SETTINGS

Align the arrow positioned with the 70V values to the desired wattage setting. Turning the dial one click stop in either direction increases or decreases the loudspeaker's input power.

100V TAP SETTINGS

Align the arrow positioned with the 100V values to the desired wattage setting. Turning the dial one click stop in either direction increases or decreases the loudspeaker's input power.

10. After the loudspeaker is installed, and transformer tap adjustments are made, the grille can be installed. The grille is held in place by several small, powerful magnets on the loudspeaker frame. Place the grille against the loudspeaker and the magnets will hold it firmly in place. When properly installed, the grille should make contact with the ceiling all the way around the loudspeaker.

Figure 15:
Grille Installation

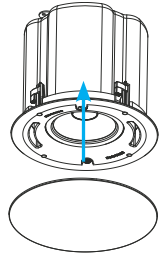

PS-C85RTBF AND PS-C85BB TECHNICAL SPECIFICATIONS

SKU	40231 PS-C85RTBF; 40232 PS-C85BB - Each
Transducers LF Driver	8" (203mm) Aluminum Cone, Santoprene Surround, Ferrite Magnet, 60.55mm Voice Coil
Transducers HF Driver	1.4" (36mm) Aluminum Dome Compression Driver, Neodymium Magnet, 36mm Voice Coil, 1500Hz Cross Frequency, 1" (25mm) Exit Size
Frequency Range (-10dB) *	36.6Hz - 25kHz
Frequency Range (-3dB) *	41.4Hz - 20kHz
Long Term Power Handling (IEC) ‡	150 Watts (600 Watts Peak), 100 Hours
Program Power	300 Watts (1200 Watts Peak), Two Hours
Sensitivity (2.83V/1M) §	91dB SPL
Long Term - Maximum SPL ‡	112dB (118dB Peak)
Program Power - Maximum SPL ‡	115dB (121dB Peak)
Rated Impedance	8 ohm Bypass
Transformer Taps (8 ohm Bypass)	70V: 120W, 60W, 30W, 15W 100V: 120W, 60W, 30W (8 ohm Bypass)
Collar Coverage Pattern 1kHz to 10kHz †	120 Degrees Axis Symmetric
Horn Coverage Pattern 1kHz to 10kHz †	80 Degrees Axis Symmetric
Collar Directivity Factor (Q)	5.7 (Average 1kHz to 16kHz)
Horn Directivity Factor (Q)	8.65 (Average 1kHz to 16kHz)
Collar Directivity Index (DI)	7.5dB (Average 1kHz to 16kHz)
Horn Directivity Index (DI)	9dB (Average 1kHz to 16kHz)
Back Box Enclosure Material	Powder Coated Steel (PS-C85BB, sold separately)
Baffle Material	PC/ABS (UL94V-0) (PS-C85RTBF)
Grille Material	Steel
Capture Thickness	0" to 2.12" (0mm to 53.84mm)
Suspension Points	Two, on Top Surface
Enclosure Cubic Volume	0.83 Cubic Feet (23.5 Cubic Liters)
Enclosure/Port Tuning	41.1Hz
Input Connector	Four pin, Euroblock with Loop Output Connections
Operating Temperature Range	-40 F (-39.96 C) to 140 F (60 C)
Agency Listings	UL 1480A, UL 2043
Conformity	NFPA 90A, NFPA 70
Round Trimless Grille (Dia)	11.17" (283.8mm)
Square Trimless Grille (WxH)	11.18" x 11.18" (284mm x 284mm)
System Assembly Dimensions (Dia x D)	11.07" x 7.22" (281.1mm x 184.4mm)
Mounting Depth (System, D)	7.14" (181.4mm)
Cutout Dimensions (System, Dia)	10.125" (257mm)
Product Weight (System, no Grille)	18.15 lbs. (8.23kg) EA
Product Weight (System, with Grille)	18.7 lbs. (8.48kg) EA
Shipping Weight	23.15 lbs. (10.15kg) PS-85RTBF; 18.65 bs. (8.46kg) PS-C85BB (sold separately)

INCLUDED ACCESSORIES

- (1) Round White Loudspeaker Grille (Black Grille Optional)
- (1) Cutout Template
- (1) Euroblock Wire Connector
- (1) Variable Dispersion Horn
- (1) Collar Removal Tool

* In half space | † Average 1 kHz to 10 kHz | ‡ IEC 268-5 standard, with 6 dB crest factor | § Measured in half space, ave 100 Hz - 10 kHz | UL evaluated frequency range of 50-20kHz

OPTIONAL ACCESSORIES

- Replacement Horn/Collar Kit (EA) | 40251
- Replacement Round Grille White (PR) | 40239
- Round Grille Black (PR) | 40240
- Square Adaptor w/ Grille White (PR) | 40241
- Square Adaptor w/ Grille Black (PR) | 40242
- Flex Bracket (5PR) | 40270
- PS-C85BB Tile Bridge (6 Each) | 40277
- Metal Pre-construction Bracket (6 Pack)
- Tile Support Rails w/ C-Ring (PR)

CERTIFICATIONS

SAFETY AGENCY COMPLIANCE

Sonance Professional Series Loudspeaker model PS-C85RTBF with PS-C85BB meets the following standards:

UL-2043 fire tested for heat and visible smoke release for discrete products and their accessories installed in air handling spaces.

NFPA-70 National Electric Code 1996, article 300-22(c).

NFPA-90A Installation of Air Conditioning and Ventilation Systems, section 2-3.10.1 (a), exception 3.

UL-1480A

IMPEDANCE 8 OHMS

MAX RATED POWER 150 WATTS

SUITABLE FOR USE IN AIR HANDLING SPACES

LISTED GENERAL SIGNALING EQUIPMENT SPEAKER



TECHNICAL ASSISTANCE AND SERVICE

The Technical Assistance Department at Sonance is available at (949) 492-7777 to answer any questions concerning the operation and installation of your loudspeakers between the hours of 7:00 AM and 5:00 PM Pacific time, Monday through Friday, except holidays.

In the event your unit should need repair or service, you may return the unit to your authorized dealer or use the following guidelines:

PLEASE KEEP ORIGINAL PACKAGING WHEN POSSIBLE.

1. Be prepared to state the model number and / or serial number, date of purchase, and dealer's name and address when calling.
2. Contact Sonance directly at (949) 492-7777 or at www.sonance.com. **YOU MUST HAVE PRIOR AUTHORIZATION TO RETURN YOUR UNIT.**
3. If you are returning the product directly to Sonance, call us to obtain a return authorization number (RMA) before shipping.
4. Ship the product via United Parcel Service, Federal Express, or other package delivery service. Please do not use the U.S. Postal Service.
5. Include the return authorization number on the shipping label. Please do not write the RMA number directly on the carton.
6. Ship to:

Attn: Quality Assurance Department
RMA# (include RMA number here)
Sonance
11016 Mulberry Ave.
Suite B
Fontana, CA 92337

LIMITED FIVE (5) YEAR WARRANTY

Sonance warrants to the first end-user purchaser that this Sonance-brand product ("Product"), when purchased from an authorized Sonance Dealer/Distributor, will be free from defective workmanship and materials for the period stated below. Sonance will at its option and expense during the warranty period, either repair the defect or replace the Product with a new or re-manufactured Product or a reasonable equivalent.

EXCLUSIONS

TO THE EXTENT PERMITTED BY LAW, THE WARRANTY SET FORTH ABOVE IS IN LIEU OF, AND EXCLUSIVE OF, ALL OTHER WARRANTIES, EXPRESS OR IMPLIED, AND IS THE SOLE AND EXCLUSIVE WARRANTY PROVIDED BY SONANCE. ALL OTHER EXPRESS AND IMPLIED WARRANTIES, INCLUDING THE IMPLIED WARRANTIES OF MERCHANTABILITY, IMPLIED WARRANTY OF FITNESS FOR USE, AND IMPLIED WARRANTY OF FITNESS FOR A PARTICULAR PURPOSE ARE SPECIFICALLY EXCLUDED.

No one is authorized to make or modify any warranties on behalf of Sonance. The warranty stated above is the sole and exclusive remedy and Sonance's performance shall constitute full and final satisfaction of all obligations, liabilities and claims with respect to the Product.

IN ANY EVENT, SONANCE SHALL NOT BE LIABLE FOR CONSEQUENTIAL, INCIDENTAL, ECONOMIC, PROPERTY, BODILY INJURY, OR PERSONAL INJURY DAMAGES ARISING FROM THE PRODUCT, ANY BREACH OF THIS WARRANTY OR OTHERWISE.

This warranty statement gives you specific legal rights, and you may have other rights which vary from state to state. Some states do not allow the exclusion of implied warranties or limitations of remedies, so the above exclusions and limitations may not apply. If your state does not allow disclaimer of implied warranties, the duration of such implied warranties is limited to period of Sonance's express warranty. Your Product Model and Description: PS-C85RTBF and PS-C85BB. Warranty Period for this Product: Five (5) years from the date on the original sales receipt or invoice or other satisfactory proof of purchase. Additional Limitations and Exclusions from Warranty Coverage: The warranty described above is non-transferable, applies only to the initial installation of the Product, does not include installation of any repaired or replaced Product, does not include damage to allied or associated equipment which may result for any reason from use with this Product, and does not include labor or parts caused by accident, disaster, negligence, improper installation, misuse (e.g. overdriving the amplifier or loudspeaker, excessive heat, cold or humidity), or from service or repair which has not been authorized by Sonance. Obtaining Authorized Service: To qualify for the warranty, you must contact your authorized Sonance Dealer/Installer or call Sonance Customer Service at (949) 492-7777 within the warranty period, must obtain a return merchandise number (RMA), and must deliver the Product to Sonance shipping prepaid during the warranty period, together with the original sales receipt, or invoice or other satisfactory proof of purchase.

