

newair[®]

SKU: AB-600B

60 Can Mini Beverage Fridge

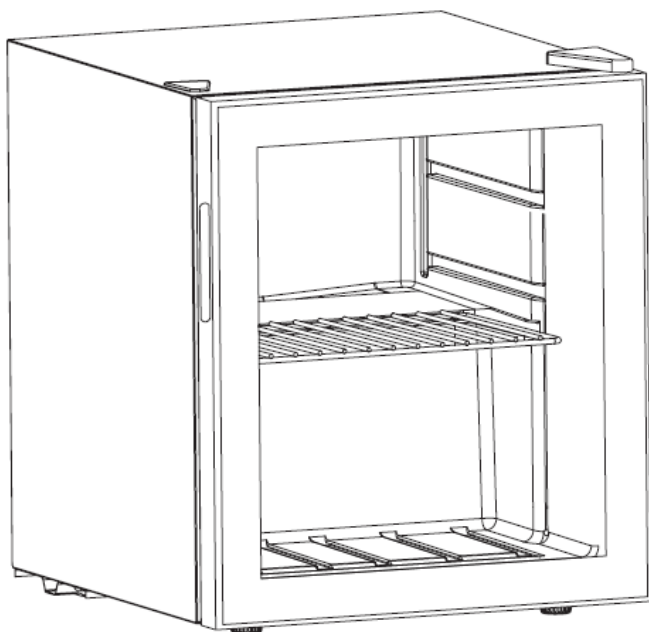

OWNER'S MANUAL

Read and save these instructions.

Intertek
Manual v1.0

READ AND SAVE THESE INSTRUCTIONS.

TABLE OF CONTENTS

Register Your Product Online.....	3
Safety Information & Warnings	4
Parts List.....	7
Assembly & Installation	8
Operating Instructions	12
Cleaning & Maintenance.....	14
Troubleshooting.....	15
Limited Manufacturer's Warranty	17

SPECIFICATIONS

MODEL NO.	AB-600B
VOLTAGE:	110-120V
CURRENT:	1.3A
FREQUENCY:	60Hz
POWER CONSUMPTION:	85W
CAN CAPACITY:	60
TEMPERATURE RANGE:	37°F - 65°F
REFRIGERANT:	R600a
NET WEIGHT	37.2 lbs.
UNIT DIMENSIONS	18.9"D x 16.93"W x 19.69"H (20.28" w/hinge)

REGISTER YOUR PRODUCT ONLINE

Register Your NewAir Product Online Today!

Take advantage of all the benefits product registration has to offer:



Service and Support

Diagnose troubleshooting and service issues faster and more accurately



Recall Notifications

Stay up to date for safety, system updates and recall notifications



Special Promotions

Opt-in for NewAir promotions and offers

Registering your product information online is safe & secure and takes less than 2 minutes to complete:

newair.com/register

Alternatively, we recommend you attach a copy of your sales receipt below and record the following information, located on the manufacturer's nameplate on the rear of the unit. You will need this information if it becomes necessary to contact the manufacturer for service inquiries.

Date of Purchase: _____

Serial Number: _____

Model Number: _____

SAFETY INFORMATION & WARNINGS

Your safety and the safety of others are very important to us.

To reduce the risk of fire, electrical shock, or injury when using your NewAir appliance, follow these basic precautions



This is the Safety Alert Symbol. This symbol alerts you to potential hazards that may result in serious injury. All safety messages will follow the Safety Alert Symbol and either the words "**DANGER**" or "**WARNING**."

DANGER: Danger means that failure to heed this safety statement may result in severe injury or death.

WARNING: Warning means that failure to heed this safety statement may result in extensive product damage, serious injury, or death.

CAUTION: Caution means that failure to heed this safety statement may result in minor or moderate injury, or property or equipment damage.

**DANGER - RISK OF FIRE OR EXPLOSION. FLAMMABLE REFRIGERANT USED.
TO BE REPAIRED ONLY BY TRAINED SERVICE PERSONNEL. DO NOT PUNCTURE
REFRIGERANT TUBING.**

All safety messages will alert you to what the potential hazard is, tell you how to reduce the chance of injury, and let you know what can happen if the instructions are not followed.



IMPORTANT SAFETY INSTRUCTIONS

Before this fridge is used, it must be properly positioned and installed as described in this manual. Please read this manual carefully. To reduce the risk of fire, electrical shock or injury when using the appliance, follow basic precautions, including the following:

- Always plug into a grounded 3-prong outlet. Do not remove grounding prong, do not use an adapter, and do not use an extension cord.
- Do not use if the power supply cord is damaged. If damaged, do not use the appliance. Contact customer service immediately.
- It is recommended that a separate circuit (serving only your appliance) be used for this fridge. Use receptacles that cannot be turned off by a switch or pull chain.
- Never clean appliance parts with flammable fluids or harsh chemicals. These fumes can create a fire hazard or explosion.
- Do not store or use gasoline or other flammable vapors and liquids in the vicinity of this fridge or any other appliance.
- Before proceeding with cleaning and maintenance operations, make sure to unplug the appliance.
- Do not connect or disconnect the power cord with wet hands.
- Do not attempt to repair or replace any part of your appliance unless it is specifically recommended in this manual. All other servicing should only be recommended by NewAir. Contact customer service if you have any issues arise with your fridge.



FOLLOW WARNING CALL OUTS BELOW ONLY WHEN APPLICABLE TO YOUR MODEL

- Use two or more people to move and install the fridge. Failure to do so can result in injury.
- To ensure proper ventilation for your fridge, the front must be completely unobstructed. Choose a well-ventilated area with temperatures above 60°F (16°C) and below 90°F (32°C). This fridge must be installed in an area protected from wind, rain, or water spray of any kind.
- This fridge should not be placed next to ovens, grills or similar sources of heat.
- This fridge must be installed with all electrical connections in accordance with state and local codes.
- The fuse (or circuit breaker) size should be 15 amperes.

- It is important for the fridge to be leveled in order to work properly. For a stable installation, make sure the appliance is placed on a flat, level, and solid surface.
- Ensure that the surface on which the appliance is placed is strong enough to hold the combined weight of the fridge and the items stored inside.
- This fridge is not intended for use by This appliance is not intended for use by persons (including children) with reduced physical, sensory or mental capabilities, or lack of experience and knowledge, unless they have been given supervision or instruction concerning use of the appliance by a person responsible for their safety.
- Young children must be supervised to ensure safety around this fridge or any electrical appliance.
- Do not use solvent-based cleaning agents or abrasives on the interior. These cleaners may damage or discolor the interior.
- Keep fingers out of the "pinch point" areas. Clearance between the door and body of the fridge are intentionally small. Be careful closing doors when children are around.
- The temperature range for this beverage refrigerator is optimized for beverage storage. Perishable food items may require a different storage environment.
- Do not place hot food or beverages into the appliance.
- Close the fridge door immediately after putting in any items to keep the internal temperature relatively constant.
- Avoid placing any objects on top of the appliance.
- This is an electrical appliance. To avoid injury from electrical shock, do not operate the unit with wet hands, while standing on a wet surface, or while standing in water. Do not use outdoors or in wet conditions.
- When positioning or moving the appliance, ensure that it is not turned upside down, or tilted more than 45°
- Never pull the power cord to disconnect it from the outlet. Grasp the plug and pull it from the outlet.
- Never lift, carry or drag the appliance by the power cord.
- This appliance is designed for household, non-commercial use only. Any other use will void the warranty.
- Do not plug into the power outlet before set-up is completed.
- Do not move this appliance without emptying it and securing the door in a closed position.

PARTS LIST

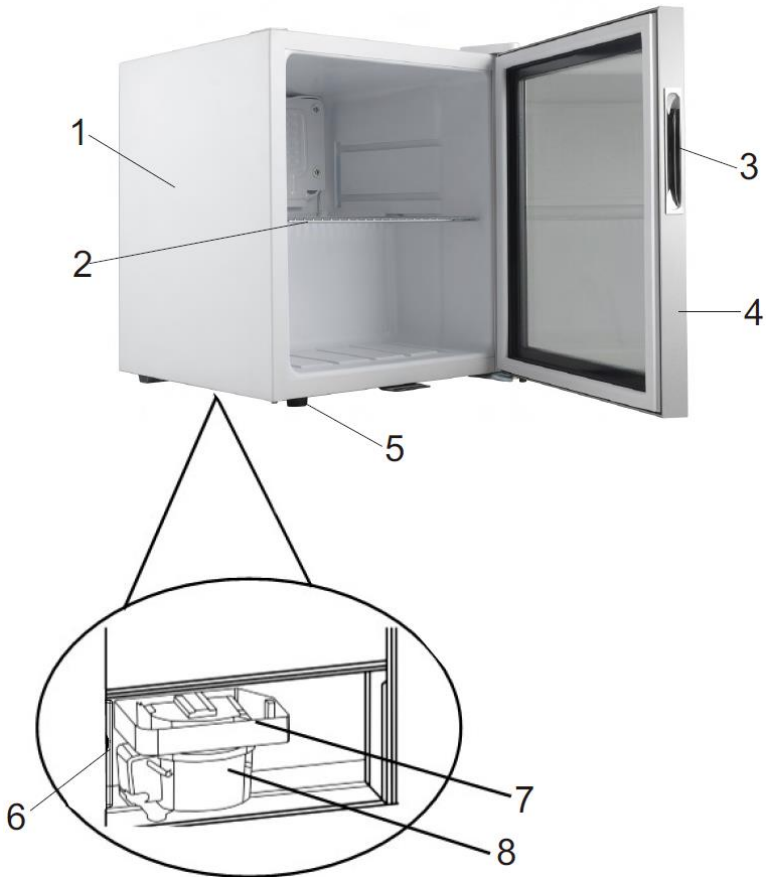

1. Fridge
2. Shelf
3. Door handle
4. Door frame
5. Leveling legs (1 big and 1 small)
6. Temperature control (back)
7. Condensation drip tray (back)
8. Compressor (back)

ASSEMBLY & INSTALLATION



To reduce the risk of fire, electrical shock, or injury when using your appliance, follow these basic precautions.

Read all instructions before using the appliance.

WARNING: An empty beverage refrigerator can be hazardous for children or small pets. If disposing of the beverage refrigerator, remove gasket seals, latches, lids, and the entire door from your unused fridge, or take other action to ensure the beverage refrigerator is harmless.

Never allow children to operate, play with, or crawl inside the appliance.

Never clean appliance parts with flammable fluids or harsh chemicals. The fumes can create a fire hazard or explosion.

Do not store or use gasoline or any other flammable vapors and liquids in the vicinity of this or any other appliance. The fumes can create a fire hazard or explosion.

BEFORE FIRST USE

- Remove the exterior and interior packing.
- Before connecting the fridge to a power source, let it stand upright for approximately 24 hours. This will reduce the possibility of a malfunction in the cooling system from handling during transportation.
- Clean the interior surface with lukewarm water using a soft cloth.

INSTALLATION

- This fridge is designed for freestanding installation in a dry, well-ventilated room.
- **WARNING: placing beverages up against the back panel of the fridge could cause cans or bottles to rupture due to excessively low temperatures. Always allow room for air circulation between the back panel and any drinks.**
- **WARNING:** Do not store or install the appliance outdoors.
- **CAUTION:** This appliance is designed for storing and cooling beverage or wines. Do not store perishable food, medicine or other medical products. Do not overcrowd the inside of the fridge.
- Place your appliance on a hard and level floor that is strong enough to support it when it is fully loaded.
- To level your appliance, adjust the leveling legs at the bottom of the appliance if needed.
- Allow of at least 5 inches (127mm) of space between the back and sides of the appliance, for proper air circulation to cool the compressor and condenser.
- Do not install the appliance on carpet.
- Do not install the appliance near an oven or other heating source. Direct sunlight may affect the acrylic coating, and heat sources may increase electrical consumption. For best performance, do not install the appliance behind a cabinet door or under a countertop.
- Avoid extremely hot or cold ambient temperatures, as they may cause the fridge to perform poorly. Install only in areas with ambient temperatures between 60°F and 90°F
- Avoid placing the fridge in an area where it may be exposed to water or excess moisture.
- Plug the fridge into its own grounded wall outlet. Do not, under any circumstances, cut or remove the third (ground) prong from the power cord. Any questions concerning power and/or grounding should be directed toward a qualified electrician or customer service.

ELECTRICAL CONNECTION

WARNING: *Improper use of the grounded plug can result in the risk of electrical shock. If the power cord is damaged, do not use the appliance. Contact NewAir customer service immediately.*

- This fridge requires a standard 115/120 Volt AC ~/60Hz electrical ground outlet with a three-prong power plug.
- Have the wall outlet and circuit checked by a qualified electrician to ensure the outlet is properly grounded. The cord should be secured behind the appliance and not left exposed or dangling to prevent accidental injury.
- The fridge should always be plugged into its own individual electrical outlet which has a voltage rating that matches the rating label on the appliance. This provides the best performance, and it also prevents overloading house wiring circuits that could cause a fire hazard from being overheated.
- Never unplug the appliance by pulling the power cord. Always grip the plug firmly and pull straight out from the receptacle.
- Do not use this fridge via an extension cord.

REVERSING THE DOOR SWING

Tools needed: flathead screwdriver, Phillips head screwdriver

CAUTION: Before you begin, unplug the fridge from power.

To remove the door:

1. Using a flathead screwdriver carefully pry the plastic hinge cover off.
2. Using a Phillips head screwdriver, remove the screws and take off the top hinge. Keep the parts together and set them aside.
3. Lift the door off the bottom hinge and set the door aside.
4. Remove the bottom hinge by removing the screws with a Phillips head screwdriver.

To reinstall the door:

1. Using a flathead screwdriver, remove the plugs and cover from the opposite corner of the top front of the fridge. Set aside.
2. Install the bottom hinge at the opposite corner and fasten the screws.
3. Position the door on the bottom hinge.
4. Align the door on the bottom hinge and install the top hinge.
5. Push the plugs and covers into the corresponding holes on the original hinge insert.

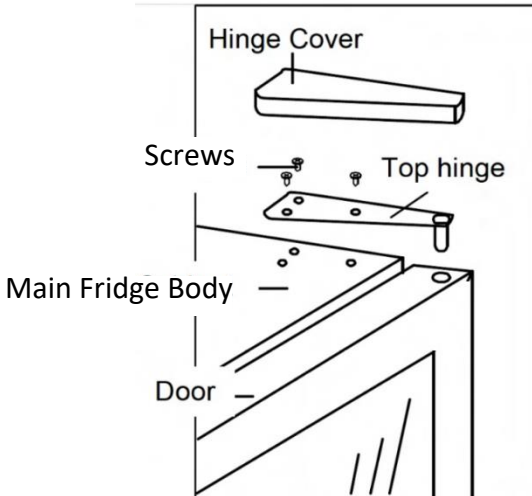

OPERATING INSTRUCTIONS

It is recommended you install the appliance in a place where the ambient temperature is above 60°F (16°C) and below 90°F (32°C). If the ambient temperature is above or below recommended temperatures, the fridge may not run well.

SETTING THE TEMPERATURE

To control the internal temperature, turn the temperature control dial on the back of the fridge. The temperature range is from "0" to "5," where "5" is the coldest temperature setting and "0" is the warmest temperature setting.

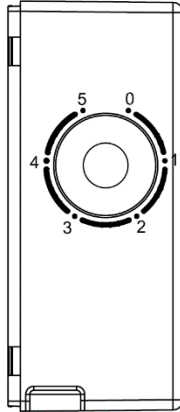

DEFROSTING

Under most conditions, the appliance does not need to be defrosted. In cold ambient temperatures and/or high humidity, some frost may build up. To defrost the appliance, set the thermostat dial to "0", remove frozen or perishable items, and the unit should be defrosted after a few hours. After defrosting, return the thermostat dial to the desired position. For faster defrosting, remove all items from the appliance, unplug the appliance, and leave the door open. Never use a knife or other metal instrument to scrape ice/frost from the inside of the unit.

FRIDGE NOISES

The following noises are normal and occur from time to time:

- Gurgling sound, caused by the refrigerant flowing through the appliance's coils.
- Humming noise made by the compressor. This noise can get louder for brief periods when the motor is switching on
- Cracking/popping sounds, resulting from the materials contraction and expansion due to temperature variations
- Internal fan rotation, to circulate the air within the refrigerator cabinet

If you are hearing a noise that doesn't seem to fall under the list above, or seems abnormal, your unit may be installed improperly, or may be faulty. Contact customer service immediately if you hear any noises that cause you concern.

CLEANING & MAINTENANCE

PREPARING FOR LONG-TERM STORAGE

If the fridge will not be used for a long time, it will be necessary to defrost the unit and completely dry the interior.

1. Disconnect the fridge from the power supply by removing the plug from the wall socket.

WARNING: Do not touch the plug when your hands are wet. Never unplug the unit by pulling the cord.

2. Leave the door open until the unit is completely dry inside. Place a towel at the bottom of the inside of the unit to prevent leakage onto the floor.

CAUTION: Store the unit out of the reach of children. If you have children, you may want to take additional precautions such as removing the door.

CLEANING THE FRIDGE

- Unplug from power and remove all items, including shelves.
- Wipe the interior with a warm water and baking soda solution. The solution should be about 2 tablespoons of baking soda to one quart of water.
- Wipe down the shelves with a mild detergent solution.
- Wipe down the outside of the fridge with warm water and mild liquid detergent.
- Do not use steel wool or a steel brush on the stainless steel. These will erode the stainless steel and cause it to rust.

CAUTION: Failure to unplug the appliance before cleaning could result in electric shock or personal injury.

MOVING THE FRIDGE

- Remove all items from inside the appliance.
- Leave the door open until the unit is completely dry inside. Place a towel at the bottom of the inside of the unit to prevent leakage onto the floor.
- Securely tape down shelves inside the unit, and tape the door shut.
- Turn the adjustable legs up into the base to avoid damaging them.
- Keep upright throughout all transportation.

TROUBLESHOOTING

Problem	Possible Causes	Solution
The fridge isn't running	<ul style="list-style-type: none"> • There is a power failure • The fridge is not plugged in • A house fuse has blown, or the circuit breaker is tripped 	<ul style="list-style-type: none"> • Ensure the fridge is plugged in and that the power outlet is functional • Replace the broken fuse or reset the breaker
The fridge isn't cold enough	<ul style="list-style-type: none"> • The fridge is placed too close to a heat source • The door is being opened too often • The door is not closed completely • The door gasket does not seal properly 	<ul style="list-style-type: none"> • Adjust the temperature • Keep the fridge away from sunshine or other heat sources • Close the door tightly and do not open the door too frequently or for a long period of time • Ensure the door gasket is not loose
The fridge turns itself on and off frequently	<ul style="list-style-type: none"> • The ambient temperature is too low or high • The inside of the fridge is overcrowded with items • The door is opened too often • The door is not closed completely • The door gasket does not seal properly 	<ul style="list-style-type: none"> • Decrease or increase the ambient temperature • Do not overcrowd the inside of the fridge • Close the door tightly and do not open the door too frequently or for a long period of time • Ensure the door gasket is not loose • It is normal for the fan to turn on and off to circulate the air inside of the unit for even temperature distribution and to save energy

Problem	Possible Causes	Solution
The fridge makes too much noise	<ul style="list-style-type: none"> • The noises are part of normal operation (see above) • The unit is not installed properly • The unit is malfunctioning 	<ul style="list-style-type: none"> • It is normal that as each cooling cycle ends, you may hear rattling or gurgling sounds caused by the flow of refrigerant in the appliance. The high-efficiency compressor may make a pulsating or high-pitched sound • Some popping or cracking noises are normal. They are caused by expansion and contraction of the inside walls due to temperature changes • Make sure the fridge is on a hard and level surface. Do not place the fridge on carpet
The door does not close properly	<ul style="list-style-type: none"> • The fridge is not level • The door was reversed and not properly installed • The shelves are out of position 	<ul style="list-style-type: none"> • Make sure the fridge is on a hard and level surface. Avoid placing the fridge on a soft or carpeted surface • Reinstall the door • Correctly install the shelves
Condensation builds up on the glass door	<ul style="list-style-type: none"> • Ambient temperature or humidity is too high. 	<ul style="list-style-type: none"> • Lower the room humidity/temperature by using a dehumidifier or air conditioner.
The fridge is frosting often	<ul style="list-style-type: none"> • The door was not closed completely • The door gasket is not sealing • Use a screwdriver to loosen the screws to reposition the door/hinge and tighten the screws • Ambient temperature or humidity is too high 	<ul style="list-style-type: none"> • Close the door tightly and do not open the door too frequently or for a long period of time • Reinstall the door • Ensure the door gasket is not loose • Lower the room humidity/temperature with a dehumidifier or air conditioner.

LIMITED MANUFACTURER'S WARRANTY

This appliance is covered by a limited manufacturer's warranty. For one year from the original date of purchase, the manufacturer will repair or replace any parts of this appliance that prove to be defective in materials and workmanship, provided the appliance has been used under normal operating conditions as intended by the manufacturer.

Warranty Terms:

During the first year, any components of this appliance found to be defective due to materials or workmanship will be repaired or replaced, at the manufacturer's discretion, at no charge to the original purchaser. The purchaser will be responsible for any removal or transportation costs.

Warranty Exclusions:

The warranty will not apply if the damage is caused by any of the following:

- Power failure
- Damage in transit or when moving the appliance
- Improper power supply such as low voltage, defective household wiring or inadequate fuses
- Accident, alteration, misuse or abuse of the appliance such as using non-approved accessories, inadequate air circulation in the room or abnormal operating conditions (extreme temperatures)
- Use in commercial or industrial applications
- Fire, water damage, theft, war, riot, hostility or acts of God such as hurricanes, floods, etc.
- Use of force or damage caused by external influences
- Partially or completely dismantled appliances
- Excess wear and tear by the user

Obtaining Service:

When making a warranty claim, please have the original bill of purchase with purchase date available. Once confirmed that your appliance is eligible for warranty service, all repairs will be performed by a NewAir™ authorized repair facility. The purchaser will be responsible for any removal or transportation costs. Replacement parts and/or units will be new, re-manufactured or refurbished and is subject to the manufacturer's discretion. For technical support and warranty service, please email support@newair.com