

USER MANUAL
PORTABLE INDUCTION COOKER

EN

كتيب الاستخدام
موقد الحث المحمول

AR



We advise you to read this manual carefully, as it contains all the instructions for managing the appliance's aesthetic and functional qualities.
For further information on the product: www.smeg.com

ننصح بقراءة هذا الكتيب بعناية حيث يضم جميع التعليمات التي تضمن الحفاظ على الخصائص الجمالية والوظيفية للمنتج الذي قمت بشرائه.
للمزيد من المعلومات عن المُنتج يرجى زيارة www.smeg.com

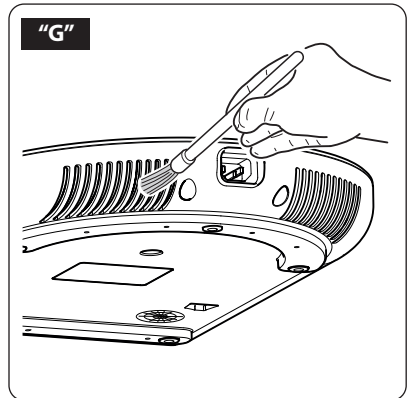
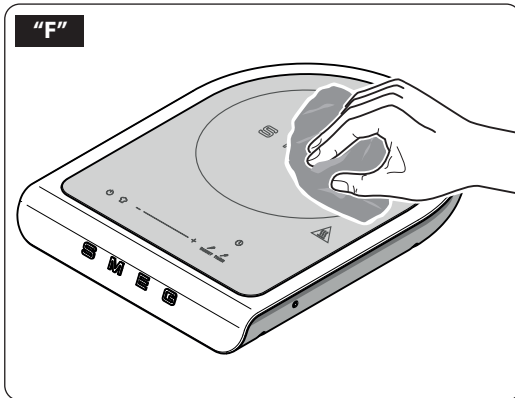
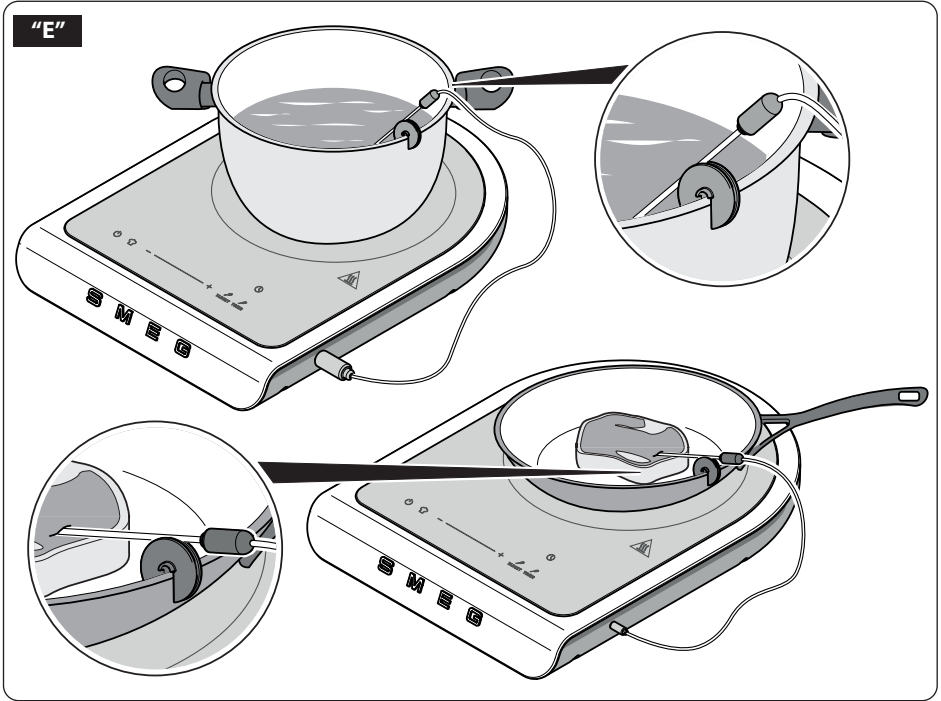
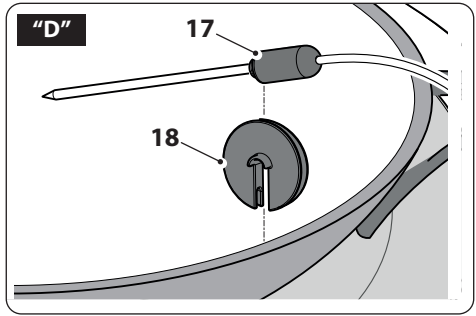
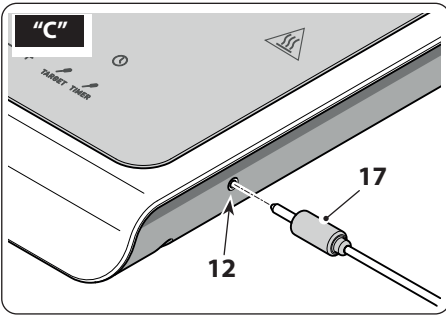

Important information for the user / مردختس مر ل ل ة مره ت امر ول ع مر



Instructions / تحذيرات

General information on this user manual, on safety and final disposal / معلومات عامة عن دليل استخدام هذا الجهاز وسلامة استخدامه وكيفية التخلص عن الجهاز بشكل نهائي



Description / الوصف

Appliance description / وصف الجهاز



Use / الإستعمال

Information on using your appliance / معلومات عن استخدام الجهاز



Cleaning and care / ة ناي ص ل ا و في ظ ن ت ل ا

Information for proper cleaning and maintenance of the appliance / معلومات لتنظيف وصيانة الجهاز بشكل صحيح



Safety instructions / ة مر ال س ل ل ري ذ ح ت



Information / معلومات



Advice / اقتراحات



Scansiona il QR code per un accesso rapido al portale My Smeg Assistant

امسح رمز الاستجابة السريعة ضوئياً للوصول السريع إلى بوابة My Smeg Assistant

NOTES

A series of horizontal dotted lines providing space for notes.

The manufacturer reserves the right to make any changes deemed useful for the improvement of its products without prior notice. The illustrations and descriptions contained in this manual are therefore not binding and are merely indicative.

”تحتفظ جهة التصنيع لنفسها بالحق في القيام بجميع التعديلات التي تراها مناسبة لتحسين منتجاتها دون إنذار مسبق. ولذلك، لا تُعتبر الرسوم التوضيحية والأوصاف الواردة في هذا الدليل ملزمة وإنما ذات قيمة إرشادية فقط“



1 Warnings

This user manual is an integral part of the appliance and must therefore be kept in its entirety and on-hand for the whole working life of the appliance.

1.1 Intended use

Failure to comply with the safety recommendations and not reading the instruction manual can lead to improper use of the appliance by the users and consequent personal injury.

- The appliance must only be used as a portable induction cooker. All other use is considered improper. Do not use the appliance for purposes different to those for which it is intended.
 - The appliance is intended for use in the home and similar environments, such as:
 - in the kitchen area for the staff of shops, offices and other work environments;
 - in bed and breakfast and agritourism accommodation;
 - by guests at hotels and motels, and in residential environments.
 - Other uses, in restaurants, bars and cafés for example, are improper.
 - Do not use the appliance outdoors.
 - Do not use the appliance near water, in damp places or near a swimming pool.
 - Do not install the appliance near sources of heat or flammable materials; in a room subject to moisture, rain, potential gas leaks or on an unlevelled floor.
- Do not install the appliance on boats or caravans.
 - Place the appliance on a horizontal and stable worktop, avoiding any delicate surfaces (e.g. lacquered furniture, tablecloths, etc.). Objects such as lids, vases, etc. should not be placed on top of the appliance.
 - Do not insert the appliance into a closed cabinet (built-in type).
 - The appliance is not designed to operate with external timers or with remote-control systems.
 - This appliance may be used by persons with reduced physical, sensory or mental capabilities (including children from the age of 8) provided they are supervised or instructed on the safe use of the appliance and have understood the hazards connected with its use.
 - Children must not play with the appliance.
 - Keep the appliance and its power cable out of the reach of children under 8 years of age.
 - Cleaning and maintenance can be performed by children from the age of 8, only if they are closely supervised by an adult.



Important safety information

1.2 General safety warnings

Follow all safety instructions for safe use of the appliance: Electrocutation Hazard, since the machine is powered by electricity, the following safety warnings must be complied with:

- Read this user manual carefully before using the appliance.
 - Do not leave the appliance unattended during use.
 - Do not immerse the appliance, the power cable, the plug or the base in water or any other liquid. Do not remove the plug from the socket by pulling on the cable or with wet hands.
 - Do not use the appliance when the power cable or the plug are damaged or if the appliance has fallen on the floor or is damaged in any way whatsoever.
 - In the event of a fault, or if the power supply cable is damaged, have the appliance repaired only by a qualified technician or by an authorised after-sales service.
 - The cable is deliberately short to prevent accidents.
 - Do not allow the power cable to hang over the edge of the table or any other surface, or to come into contact with hot surfaces.
 - Do not allow the electrical power cable to come into contact with sharp edges.
 - Do not position the appliance above or near gas or electric hob burners when they are in use, inside an oven or near other heat sources.
- Do not touch the plug with wet hands.
 - Make sure that the power outlet used is always freely accessible, because only in this way can it be unplugged when necessary.
 - If the plug must be removed from the socket, grasp the plug directly and do not pull the cable.
 - If the machine should suffer a malfunction, do not attempt to repair it. Switch the appliance off, remove the plug from the outlet and contact the Technical After-sales Service.
 - Do not try to make modifications or repair the appliance: in the event of a fault, have it repaired by a qualified technician or contact the Technical After-Sales Service.



Injury hazard! Improper use of the appliance can cause injuries. Disconnect the plug before cleaning.

- Keep packaging material out of the reach of children.
- Never try to put out a fire/flames using water: turn off the appliance, remove the plug from the outlet and smother the flame with a lid or fire blanket.
- Always disconnect the appliance from the power supply when it is not in use, if left unattended or in the case of a fault.
- Always disconnect the appliance from the power supply before assembly/disassembly of components.

Important safety information



- Always disconnect the appliance from the power supply and let the appliance cool down before cleaning.
- Do not use the appliance with parts or accessories produced by other manufacturers.
- Only use the manufacturer's original spare parts. The use of spare parts not recommended by the manufacturer could lead to fires, electric shocks or personal injury.
- Only place the appliance on level and dry surfaces.
- Do not wash the appliance in the dishwasher. Do not spill liquids on the power plug and on the power base. Failure to comply with these warnings can cause death, a fire or electrocution.
- Do not use an adapter.
- Only use type-approved extensions suitable for the type of appliance.
- Do not try to make modifications or repair the supplied power cable if it is damaged or In the event of a fault.



Make sure that the power cable connector is fully inserted into the product connector.

1.3 Safety recommendations for this appliance

- Do not move the appliance together with the pot.
- Do not heat an empty pot or overheat it to avoid dry boiling.
- Do not place metal objects such as cutlery, lids, jars, aluminium foil, etc. in the cooking area of the portable induction cooker when the appliance is turned on. Danger of burns!
- Do not place sheets of paper between the pot and the glass hot plate. The paper could catch fire!
- Do not touch the glass hot plate after removing the pot. Danger of burns!



Warning! If the glass surface is cracked, switch off the appliance to avoid the possibility of electric shock.

- Do not obstruct fans and air outlet grilles.
- Do not use aluminium foil or plastic containers on the glass hot plate.
- Only use cookwear (pots, pans...) suitable for induction and of adequate diameter (12 cm - 24 cm).
- After use, allow the appliance to cool before moving it and before cleaning the glass hot plate. The glass hot plate remains warm after use, do not touch with your hands!
- Do not use the appliance in contact with walls or under shelves, tables, etc. Leave at least 10 cm on both the left and right sides of the appliance and 50 cm above.



Important safety information

- The entire appliance gets warm when used, even if only the glass hot plate in contact with the container heats up. Use the appliance with care to avoid burns by accidentally touching the accessible scalding parts. Danger of burns!
- Do not use aggressive detergents, abrasive sponges or scouring pads to clean the appliance.
- Consult the "Cleaning and maintenance" chapter for cleaning instructions.
- This appliance cannot be placed in a cabinet or closed container during use.
- The electromagnetic fields produced by the appliance when used may cause malfunctions.

Do not use the device by placing it near objects that can be altered by electromagnetic waves such as: radios, televisions, CD, DVD or cassette players, magnetic cards (debit cards, credit cards, etc.)

- Consult a doctor if you have a pacemaker before using the portable induction cooker.



Warning! The plate is hot after cooking, please don't touch with your hands.

1.4 Manufacturer's liability

The manufacturer declines all liability for injury/damage to persons and objects due to:

- use of the appliance different from that envisioned;
- the user manual not being read;
- tampering with individual parts of the appliance;
- use of non-original spare parts;
- failure to comply with safety warnings.



Keep these instructions carefully. Whenever the appliance is transferred to other persons, it must be accompanied by these user instructions.

These instructions can be downloaded from the Web Smeg site "www.smeg.com".

1.5 Disposal



Devices bearing this symbol are subject to European Directive 2012/19/EU.

- All electric and electronic appliances must be disposed of separately from household waste, taking them to the relevant centres envisioned by the State. By disposing of the discarded device correctly, damage to the environment and risks to human health will be avoided. For further information regarding disposal of the discarded appliance, contact the Municipal Administration, the Disposal dept. or the shop where the appliance was purchased.



2 Description of the appliance (Fig.A and B)

- 1 Appliance body
- 2 Glass top hot plate
- 3 Display
- 4 ON/OFF button
- 5 "CHEF" program button
- 6 Time / power / temperature decrease button
- 7 Power adjust slider "-/+"
- 8 Time / power / temperature increase button
- 9 Temperature sensor "TARGET" button
- 10 Temperature sensor "TIMER" button
- 11 TIMER button
- 12 Temperature sensor connector socket
- 13 Support feet
- 14 Power chord
- 15 Accessory carrying case
- 16 Carrying case lid
- 17 Temperature probe
- 18 Pot clips

2.1 Before commissioning (Fig. A)

- Unpack the appliance carefully and remove all packaging materials.
- Clean the appliance body (1) and glass hot plate (2) with a damp cloth to remove any dust.
- Clean accessories in the same way.
- Make sure the appliance and accessories are dry before reassembling them.



The container used for the portable induction cooker surface must be made of metal, have magnetic characteristics and have a sufficiently flat support surface.



The parts that may come into contact with foodstuffs are made using materials that comply with the provisions of the legislation in force.

3 Description of accessories / controls (Fig.A-B)

3.1 Description of accessories (Fig. A)

Accessory carrying case (15)

The appliance comes with a case containing accessories so that the user has them readily available.

The case contains a temperature probe (17) and a pot clip (18).

Temperature probe (17)

To be used when preparing food that requires a liquid or the centre of the food to reach or maintain a certain temperature.

To enable the probe it is necessary to connect it to the portable induction cooker by fitting the connector into the socket (12).

Pot clips (18)

To be used as a fixing support for the temperature probe. The clip can be inserted on the edge of a pan or pot.



Do not put the fixing clip in contact with flames or objects at too high a temperature.



Use

3.2 Description of commands (Fig.B)

ON/OFF key (4)

Press the button to turn the appliance user interface ON or OFF.

"CHEF" program button (5)

Press the button in sequence to activate one of the following programs:
"☰ Keep Warm", "🍖 Barbecue" and "🍳 Fry".

Time/power buttons and slider (6), (7) and (8)

Tap buttons (6) and (8) to increase/decrease time, power or temperature with each tap (only with temperature probe attached).

The slider (7) allows, by sliding with your finger in the desired direction, to increase/decrease the time or power.



Power adjustment is visible via the light level bar. There are 9 power levels plus the maximum power function called "Boost".

"TARGET" temperature probe button (9)

Only with the temperature probe connected, the button allows you to activate the "TARGET" function.

"TIMER" temperature probe button (10)

Only with the temperature probe connected, this button allows you to activate the "TIMER" function.

"TIMER" button (11)

The button allows you to set a timer to automatically stop the cooking cycle when the time expires.

4 Use



Before starting the appliance, carefully read chapter "1 Warnings" and the "Before commissioning" paragraph.

4.1 Appliance accessories (Fig. A and B)

- Place the appliance on a horizontal and stable worktop that is resistant to high temperatures. Make sure all feet (13) touch on the worktop.
- Unwind the power cord completely (14).
- Connect the power plug to the power outlet making sure that the mains voltage corresponds to what is indicated on the data plate of the appliance.
- The number "88" appears on the display for one second.
- Place the container with the food to be cooked on the glass top hot plate (2).
- Press the button (4) to turn on the hob. The appliance emits a "beep" and the LED button (4) lights up; This means that it is ready to be set up.



During operation the plate (2) heats up.
Pay close attention.
Danger of burns!



4.2 Setting the power level (Fig. B)

- When the appliance is switched on, the power is set to "0" by default. To start cooking, set the power level using the slider (7) or the specific buttons (6) and (8).
- The appliance automatically starts the cooking cycle if the pot is detected.



If no pot is detected because it is not present or because it is not suitably sized, the letter "u" flashes on the display with a dash "-" underneath. The hob turns off automatically after 30 seconds if the power level is set to 0, if no other operations are performed and if no pot is detected.

- The "Boost" function is available to heat/boil a large amount of water or to carry out the most intense cooking, which allows the induction to run at the maximum power available for a limited period of time (5 minutes).
- To activate the "Boost" function, set the "P" level on the display with the slider (7) or by pressing the button (8) several times. The "Boost" function is automatically deactivated at the end of the maximum safety time of 5 minutes, after which the power is reduced to level 9.
- To deactivate the "Boost" function, set another level of power on the display with the slider (7) or by pressing the button (6) several times.
- The display shows the residual heat when completing the cooking cycle:
 - "—" low residual heat.
 - "=" medium residual heat.
 - "≡" high residual heat.



Before touching the appliance to store or clean it, wait for the residual heat indication shown on the display to disappear. Pay close attention. Danger of burns!

- Depending on the set power level, the appliance has a maximum operating time, at the end of which it switches off automatically or, in the case of the "Boost" function, returns to the lower power level. The table shows the maximum operating time:

Power level	Auto power-off time
Keep Warm	2 hours
1	6 hours
2	6 hours
3	5 hours
4	5 hours
5	1.5 hours
6	1.5 hours
7	1.5 hours
8	1.5 hours
9	1.5 hours
P	5 minutes



Use

4.3 Pausing and setting the timer (Fig. B)

Pause

- You can pause each cooking cycle by pressing and holding the button (11) for 2 seconds. The symbol "II" is shown on the display when the hob is paused.
- To resume cooking with the last parameters set and cancel the pause state, press and hold the button (11).



The appliance can be paused for 10 minutes at most. After this time the hob turns off.

Timer

You can set a timer to automatically stop the cooking cycle in progress when the countdown expires.



Before enabling the timer you need to place the pot on the plate and set the desired cooking power.

- Press the button (11) to start the timer. The LED button flashes and the display displays the time of duration "00".
- Use the buttons (6) and (8) to set the cooking timer.
- After setting the desired cooking time, wait 2 seconds or press the button (11) again. At this point the LED of the "TIMER" function remains fixed access and the countdown appears on the display.



If, with timer set, the pot is not put on the plate or is removed, the "TIMER" function is maintained for 3 minutes. At this stage the LED of the button (11) flashes. If the pot is not placed on the plate, after 3 minutes the appliance turns off.

- At the end of the countdown the cooking cycle stops, the display displays flashing "00" and a short sequence of sounds is emitted (20 seconds). After a further interval of 10 seconds with the power level set to 0, the hob turns off.



When cooking with the timer set it is always possible to vary the power via the buttons (6) and (8), or the slider (7).



You can always change the countdown when cooking with the timer set by pressing the button (11) and then acting on the buttons (6) and (8).

4.4 Button block function (Fig. B)

- Pressing the buttons (10) and (11) simultaneously allows you to lock/unlock the keypad. The key icon "🔒" lights up when the keypad is locked.
- The keypad can be locked/unlocked more than once while using the hob, without having to turn it on/off. The key lock remains active even if the supply voltage is interrupted and restored within a few seconds, as it must be turned off manually.
- If the key lock is activated, you can always turn off the unit by pressing the button (4).



If the button lock is activated, you cannot turn on and use the appliance without unlocking the keypad. Pressing the power button calls up the key icon on the display.

5 "CHEF" cooking program (Fig. B)

Pressing the button (5) in sequence calls up the "CHEF" function that makes it possible to activate the following programs:

- Keep Warm "sss"
- Barbecue "☼"
- Fry "ss"



Activate any "CHEF" program by placing the pot on the plate.

5.1 "Keep Warm" program

The program allows you to heat the hob with constant heat, to keep the flow rates warm for as long as the user wants.

- Place the pot on the hob and press the button (5) in sequence until the "sss" icon lights up; The program is active.
- The display displays "U", the plate heats up and maintains constant heat until the moment of automatic shutdown.



It is not possible to adjust the power. Tapping the adjustment buttons will not adjust the power.

- After starting the program you can set a stop timer. To set the timer refer to the "Timer" point in the paragraph "4.3 Pause and timer setting".
- The program remains active until the user changes the cooking program, turns off the appliance, when the set timer or the maximum shutdown time expires.

5.2 "Barbecue" program

The program allows you to cook meat, fish and vegetables with dedicated cooking settings for the use of grill plates. Depending on the food that the user wants to cook, it is possible to select a different barbecue program with dedicated cooking powers and times.

- Place the food-free grill plate on the hob and press the button (5) in sequence until the icon "☼" lights up; the icon flashes.
- Use the buttons (6) and (8), or the slider (7), to select the type of Barbecue program you want. The display shows the name of the selected program:
 - "b1" - Vegetable barbecue program.
 - "b2" - White meat / fish barbecue program.
 - "b3" - Steak / hamburger / bacon barbecue program.
- At the start of each program, the preheating phase is activated, during which the hob and the grill plate heat up to reach the optimal cooking temperature. During this phase, the "☼" icon flashes until the phase ends.



The warm up phase of each program has a timer and a power set by the manufacturer. These default settings cannot be changed.



During warm up it is possible to go directly to the cooking phase by pressing the button (8).

- When the "☼" icon remains fixed, it means that the preheating is finished and that the grill plate has reached the required cooking temperature.



Use

- Place the food in the grill plate, the hob will cook with a default power level.
- During cooking it is possible to set a stop timer, following the instructions provided in the cooking tables at the end of this manual. To set the timer refer to the "Timer" point in the paragraph "4.3 Pause and timer setting".



You can set the cooking timer even during the preheating phase, waiting for it to start later at the end of this phase. In this case the LED (11) blinks with a reduced frequency. When the warm up phase is over, the countdown begins and the LED (11) remains fixed.

- The power level can be changed also while cooking.



Only power levels from 6 to 9 can be selected.

"Barbecue" programs time and power

The tables show power levels and defined times for the phases of each program

Program	Warm up phase
b1	Power level: 9 Timer: 2 minutes
b2	Power level: 9 Timer: 2 minutes
b3	Power level: 8 Timer: 4 minutes



Power level and timer are NOT adjustable.



Program	Cooking phase
b1	Power level: 8 Timer: to set by the user following table "Cooking times"
b2	Power level: 7 Timer: to set by the user following table "Cooking times"
b3	Power level: 7 Timer: to set by the user following table "Cooking times"

Power levels from 6 to 9 can be adjusted.



5.3 "Fry" program

The program allows you to fry fresh foods, frozen foods and sweets with dedicated cooking settings. Depending on the food that the user wants to fry, it is possible to select a different fry program with dedicated cooking powers and times.

- Place the pot containing the oil on the hob and press the button (5) in sequence until the icon "" lights up; the icon flashes.
- Use the buttons (6) and (8), or the slider (7), to select the type of Fry program you want. The display shows the name of the selected program:
 - "F1" - Fresh food fry program.
 - "F2" - Frozen food fry program.
 - "F3" - Sweets fry program.
- At the start of each program, the preheating phase is activated, during which the hob and the oil in the pot heat up to reach the optimal cooking temperature. During this phase, the "" icon flashes until the timer expires.



The warm up phase of each program has a timer and a power set by the manufacturer. These default settings cannot be changed.



During warm up it is possible to go directly to the cooking phase by pressing the button (8).

- When the "" icon remains fixed, it means that the preheating is finished and that the oil in the pot has reached the required cooking temperature.
- Position the food in the pot, the hob will cook the food with the power level set.

- During cooking it is possible to set a stop timer, following the instructions provided in the cooking tables at the end of this manual. To set the timer refer to the "Timer" point in the paragraph "4.3 Pause and timer setting".



You can set the cooking timer even during the preheating phase, waiting for it to start later at the end of this phase. In this case the LED (11) blinks with a reduced frequency.

When the warm up phase is over, the countdown begins and the LED (11) remains fixed.

- The power level can be changed also while cooking.



Only power levels from 6 to 9 can be selected.



Use

"Fry" programs time and power

The tables show power levels and defined times for the phases of each program

Program	Warm up phase
F1	Power level: 9 Timer: 9 minutes
F2	Power level: 8 Timer: 13 minutes
F3	Power level: 8 Timer: 13 minutes



Power level and timer are NOT adjustable.

Program	Cooking phase
F1	Power level: 8 Timer: to set by the user following table "Cooking times"
F2	Power level: 7 Timer: to set by the user following table "Cooking times"
F3	Power level: 7 Timer: to set by the user following table "Cooking times"



Power levels from 6 to 9 can be adjusted.

6 Temperature probe (Fig. B, C, D and E)

The temperature probe is to be used when preparing food that requires a liquid or the centre of the food to reach or maintain a certain temperature.

Connect the probe to the hob by inserting the connector into the socket (12), the LEDs of the buttons (9) and (10) light up waiting for the user to select the type of function between "TARGET" or "TIMER".

6.1 "TARGET" function

The "TARGET" function is advised for preparations requiring that cooking stops automatically upon reaching a target temperature at the core of the food (for instance meat, seafood).

- Place the pot containing the liquid or food on the hob.
- Latch the clip (18) to the edge of the pot and dip the tip of the probe in the liquid or insert it into the food. Position the probe, place it inside the clip so that it remains in place.
- Press the button (9) to activate the function, the LED button flashes.
- Use the buttons (6) and (8) to set the target temperature; the display displays the default temperature value 70°C, and then the one set by the user.
- After 3 seconds the cooking starts, during this phase the LED of the button (9) flashes with a reduced frequency and the current temperature is shown on the display.



You can manually change the power level using the slider when cooking.

The default power level is 5.



You can manually change the set target temperature when cooking. Press the button (9) and manually change the target temperature with buttons (6) and (8).

- Once the target temperature is reached, the cooking cycle stops. The display shows the temperature reached by flashing and emitting a short sequence of sounds (20 seconds).
- The device switches off automatically after a further interval of 10 seconds.

6.2 "TIMER" function

The "TIMER" function is advised for preparations requiring that, for a given time interval, a defined temperature of a liquid being cooked is maintained (for instance, in the case of sous-vide cooking).

- Place the pot containing the liquid or food on the hob.
- Latch the clip (18) to the edge of the pot and dip the tip of the probe in the liquid or insert it into the food. Position the probe, place it inside the clip so that it remains in place.
- Press the button (10) to activate the function, the LED button flashes.
- Use the buttons (6) and (8) to set the target temperature; the display displays the default temperature value 70°C, and then the one set by the user.
- Press the button (11) and set the timer using the buttons (6) and (8).
- After 3 seconds the cooking starts, during this phase the LED of the button (10) flashes with a reduced frequency and the current temperature is shown on the display.



You can manually change the power level using the slider when cooking. The default power level is 5.



You can display or change the set target temperature when cooking. Press the button (9) and manually change the target temperature with buttons (6) and (8).



You can change the set timer when cooking. Press the button (11) and manually change the timer with buttons (6) and (8).

- Once the target temperature is reached, a sound is emitted and the countdown begins. In this phase the LED of the buttons (10) and (11) light up steadily.
- The hob will maintain the set temperature until the countdown expires.
- At the end of the countdown the cooking cycle stops, the display displays flashing "00" and a short sequence of sounds is emitted (20 seconds).
- The device switches off automatically after a further interval of 10 seconds.



Use

7 User menu

You can set the individual parameters of the appliance by using the user menu.

- Access the user menu by simultaneously holding down the buttons (5) and (9) for 4 seconds.



The operation can only be performed when the hob is switched on and no program, function or timer is active.

- Use the buttons (6) and (8) to scroll through menu items; The letter identifying the selected item is shown on the left side of the display.
- Use the slider (7) to change the value of the selected item; The number that identifies the value is shown on the right side of the display.
- To exit the menu and confirm the new settings, press and hold the button (4) for 2 seconds.



After 30 seconds of inactivity, the device switches off automatically.

User menu legend

Item	Meaning	Value
a	Button volume	0: OFF buttons volume 1: ON buttons volume
b	Acoustic signals volume	0: OFF signals volume 1: ON signals volume
c	Display brightness	Scale 0 - 9 0: Min. brightness 9 : M a x . brightness



Even with button volume set to "OFF", it is not possible to turn off the button tone (4).



Barbecue function

Recommended cooking times using the barbecue function programs.

Program	Food	Quantity	Power	Timer
b1) VEGETABLES	Courgette	80 - 100g	8	3min per side
b1) VEGETABLES	Aubergine	80 - 100g	8	2min per side
b1) VEGETABLES	Bell peppers	100g	8	5min per side
b1) VEGETABLES	Vegetable skewers	3 70g skewers	8	8min per side
b2) WHITE MEATS / FISH	Chicken breast	100g	7	2 min per side
b2) WHITE MEATS / FISH	Turkey breast	100g	7	2min per side
b2) WHITE MEATS / FISH	Fish fillets	250g	7	4min per side
b2) WHITE MEATS / FISH	Whole fish	100g	7	10min per side
b2) WHITE MEATS / FISH	Prawn skewers	100g	7	10min per side
b3) STEAKS / HAMBURGERS / BACON	Hamburger (beef)	2 100g burgers	7	Rare: 2min per side Medium: 4min per side Well done: 6min per side
b3) STEAKS / HAMBURGERS / BACON	Fillet (beef)	150g	7	Rare: 5min per side Medium: 7min per side Well done: 9min per side
b3) STEAKS / HAMBURGERS / BACON	Steak (pork)	180g	7	5 min per side
b3) STEAKS / HAMBURGERS / BACON	Bacon	180g	7	5 min per side



Cooking tables

Fry Function

Recommended cooking times using the fry function programs.



The times were defined using 900 ml of seed oil (equivalent to one bottle).

Program	Food	Quantity	Power	Timer
F1 FRESH FOODS	Mixed vegetable fry	200g	8	4min
F1 FRESH FOODS	Mixed fish fry	200g	8	3min
F1 FRESH FOODS	Chicken nuggets	200g	8	7min
F1 FRESH FOODS	Fish bites	240g	8	6min
F1 FRESH FOODS	Cutlet (chicken)	200g	8	2min per lato
F1 FRESH FOODS	Fried pizza	100g	8	4min
F2 FROZEN FOODS	Mixed vegetable fry	200g	7	7min
F2 FROZEN FOODS	Chicken nuggets	200g	7	3min
F2 FROZEN FOODS	Potato croquettes	500g	7	10min
F2 FROZEN FOODS	Chips	200g	7	5min
F3 SWEETS	Churros	-	7	5min
F3 SWEETS	Doughnuts (empty or stuffed)	70g each	7	30sec per side
F3 SWEETS	Apple fritters	20g each	7	1 min per side

Cooking tables



SOUS-VIDE cooking

It involves cooking food sealed in vacuum bags at low temperature. The food must be placed in the pot only after reaching the set temperature and kept in immersion for the suggested cooking time.



We suggest the use of the appropriate temperature probe with the selection of the "TIMER" function (11).



The recommended cooking times were defined using a pot with a quantity of water equal to 4L.

	Food	Quantity	Temperature	Power	Timer
MEAT	Beef fillet	100g	Medium: 54°C Well done: 58°C	8	20min
	Chicken breast	250g	70°C	8	56min
FISH	Codfish fillet	250g	60°C	8	24min
	Salmon steak	200g	64°C	8	18min
EGGS	Poached eggs	1 egg (60g)	68°C	5	45min
	Soft	1 egg (60g)	73°C	5	45min
	Hard boiled	1 egg (60g)	77°C	5	60min
DESSERTS AND FRUIT	Custard cream	350g	80°C	8	25min
	Fruit (such as pineapple, apricot, peaches)	250g	80°C	8	25min

Melting

Recommended cooking times to soften or dissolve foods.

	Food	Quantity	Power	Timer
	White chocolate	150g	5	5min
	Milk chocolate	150g	4	4min
	Dark chocolate	150g	5	6min
	Butter	200g	7	4min



Cleaning and maintenance

8 Cleaning and maintenance (Fig. F and G)

8.1 Warnings



Electrocution hazard.

- Remove the plug from the power outlet before cleaning the hob.
- Do not immerse the appliance in water or other liquids.
- Allow the hob to cool before cleaning.



Risk of damage to the surfaces.

- Do not use steam jets to clean the appliance.
- Do not use cleaning products containing chlorine, ammonia or bleach on parts with metal surface finishes (e.g. anodised, nickel or chrome-plated).
- Do not use abrasive or corrosive detergents (e.g. powder products, stain removers and metallic scourers).
- Do not use rough or abrasive materials or sharp metal scrapers.

8.2 Cleaning the glass top plate (Fig. F)

Clean the glass top plate (2) with a damp cloth or sponge and dishwashing detergent if necessary.



Clean the glass top plate (2) after each use.

You can gently wipe the surface of the plate (2) with a soft-bristled toothbrush and dishwashing detergent.



Pay attention to the hardness of the bristles so as not to scratch the surface of the plate.



Be careful to move pots or pans over the glass gently, so as to avoid scratches that could occur if the bottom of the pot or pan is not completely smooth.

8.3 Cleaning the machine body (Fig. G)

To keep the external surfaces in good condition, clean them regularly after all use and when they have cooled down. Clean with a soft, damp cloth.

Clean the cooling fans with a brush or vacuum cleaner and use a soft cloth.

What to do if...

Problem	Possible causes	Solution
The appliance does not turn on.	The plug was not properly plugged into the power outlet.	Make sure the plug is properly plugged into the power outlet.
	The connector was not inserted fit into the unit.	Make sure the connector is inserted correctly.
	The power button (4) was not pressed.	Press the power button (4) to turn on the unit.
	The cable is faulty.	Contact your local technical support service.
	No electricity.	Make sure the power is working properly. If the problem does not resolve, contact a qualified electrician.
The appliance turns on but cooking does not start or stops.	No crockery or crockery not positioned correctly on the burner (the letter "u" with a dash "-" flashes on the display).	Make sure that the dishes are placed correctly on the stove.
	Use of crockery not suitable for induction or of unsuitable diameter (the letter "u" with a dash "-" below flashes on the display).	Make sure that the dishes are suitable for induction and of a suitable diameter (see "1.3 Warnings for this appliance").
	The dishes are hot but are removed from the cooking zone (the letter "u" with a dash "-" flashes on the display).	Do not remove cookware from the stove during cooking.
	Button lock is active ( LED On).	Deactivate the button lock (see "4.4 Key block").
The appliance switches off during use.	The set time has expired and the appliance has stopped cooking.	If necessary, extend the cooking time if the food is not cooked enough.
	After not using it for at least 30 seconds, the automatic switch-off has been activated.	Turn the appliance back on if you want to continue using it.
Even after the power is turned off, a fan noise is heard.	The fan continues to run to cool the appliance even after it is switched off.	Wait for the time necessary for the appliance to cool down. If after a long wait the fan does not turn off, contact your local technical support service.
The appliance makes a metallic noise or a slight vibration when it starts up.	Possible metallic noises or vibrations may occur during cooking with induction hobs.	Make sure that the dishes are positioned correctly on the hob and that they are suitable for induction (see "1.3 Warnings for this appliance"). If the noises persist, contact your local technical assistance service.

Problem	Possible causes	Solution
The temperature probe is not detected by the appliance.	The probe connector has not been inserted correctly into the device.	Make sure the connector is inserted correctly.
	Probe might be damaged.	Contact your local technical support service.
The probe does not detect the temperature.	The tip of the probe has not been placed correctly in the food or liquid inside the pot.	Make sure the probe tip is positioned correctly.
	The temperature is too high or too low compared to the range of values measured by the probe.	Make sure the temperature is between 0 and 99°C so that it can be detected by the probe.
The display shows the error code: ER03	Possible presence of water or dishes placed in the display area.	Make sure that the display area is dry and free from dishes.
The display shows the error code: ER21	The temperature detected in the display area exceeds the safety limit.	Wait for the time necessary for the appliance to cool down. If the problem is not resolved, contact your local technical assistance service.
The display shows the error codes: E2 / E3	Use of empty or unsuitable crockery for induction, or the temperature of the glass or pan is too high.	Make sure you are not using empty cookware suitable for induction (see "1.3 Warnings for this appliance"). Let the appliance and the pot cool down. If the problem is not resolved, contact your local technical assistance service.
The display shows the error code: E6	Possible error in the supply voltage.	Make sure the power supply is correct. If the problem does not resolve, contact a qualified electrician.
The display shows the error code: E8	The ventilation fan is blocked by dust or fabrics.	Clean the ventilation fan and remove any foreign bodies. If the problem is not resolved, contact your local technical assistance service.
The display shows the error code: EA / EH	-	Switch off the appliance, remove the pan or leave to cool. If the problem is not resolved, contact your local technical assistance service.
The display shows the error codes: ER36 / ER42 / E4 / E5 / E7 / E9	-	Contact your local technical support service.