

# VEVOR<sup>®</sup>

**TOUGH TOOLS, HALF PRICE**

Technical Support and E-Warranty Certificate

[www.vevor.com/support](http://www.vevor.com/support)

## **DRO DISPLAY USER MANUAL**

**MODEL: SNS-3V-YE102024 / SNS-3V-YE161838**

We continue to be committed to provide you tools with competitive price. "Save Half", "Half Price" or any other similar expressions used by us only represents an estimate of savings you might benefit from buying certain tools with us compared to the major top brands and does not necessarily mean to cover all categories of tools offered by us. You are kindly reminded to verify carefully when you are placing an order with us if you are actually saving half in comparison with the top major brands.

# VEVOR®

TOUGH TOOLS, HALF PRICE

## DRO DISPLAY

MODEL: SNS-3V-YE102024 / SNS-3V-YE161838

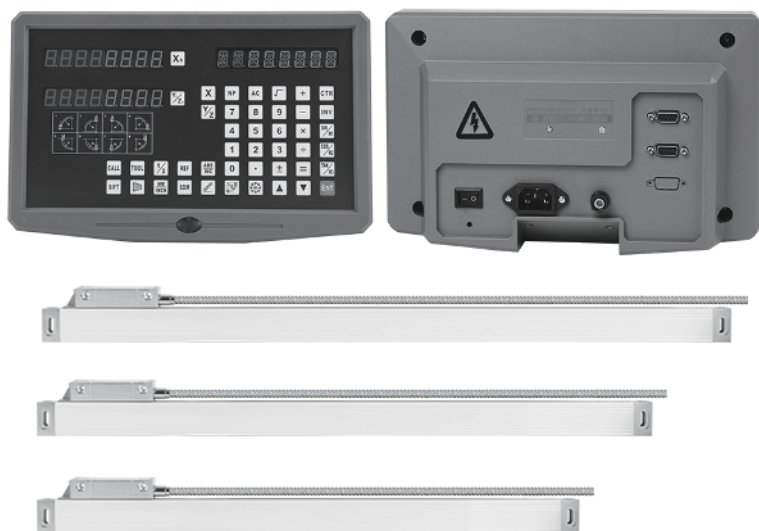

### NEED HELP? CONTACT US!

Have product questions? Need technical support? Please feel free to contact us:

**Technical Support and E-Warranty Certificate**  
**[www.vevor.com/support](http://www.vevor.com/support)**

This is the original instruction, please read all manual instructions carefully before operating. VEVOR reserves a clear interpretation of our user manual. The appearance of the product shall be subject to the product you received. Please forgive us that we won't inform you again if there are any technology or software updates on our product.

Dear Users:

Thank you for purchasing multifunction series digital readouts. Digital readouts are used in a wide variety of application. These include machine tools, infeed axes, measuring and inspection equipment, EDM, dividing apparatuses, setting tools, and measuring stations for production control. In order to meet the requirements of these applications, many encoders can be connected to the digital readouts. Read all the instructions in the manual carefully before used and strictly follow them. Keep the manual for future references.

Safety attention:

- ⌘ To prevent electric shock or fire, moisture or directly sprayed cooling liquid must be avoid. In case of any smoke or peculiar smell from the digital readout, please unplug the power plug immediately, otherwise, fire or electric shock may be caused. In such a case, do not try to repair it, please contact the Company or distributors.
- ⌘ Digital readout is a precise measuring device used with an optical Linear Scale. When it is in use, if the connection between the Linear Scale and the digital readout is broken or damaged externally, incorrect measuring values may be resulted. Therefore, the user should be careful.
- ⌘ Do not try to repair or modify the digital readout, otherwise, failure, fault or injury may occur. In case of any abnormal condition, please contact the Company or distributor.
- ⌘ If the optical Linear Scale used with the digital readout is damaged, do not use a Linear Scale of other brand. Because the performance, specification and connection of the products of different and can not be connected without the instruction of specialized technical personnel, otherwise, trouble will be caused to the digital readout.
- ⌘ With the continuous updating of products, if there are changes or changes to the sample parameters, the random files shall prevail, and the company has the final interpretation right without notice.

# Contents

---

1. Illustration of Panel and keyboard .....	4
2. Caption of the keyboard .....	5
3. Parameters settings .....	7
3.1 Parameters setup routine entrance .....	7
3.2 Parameters Settings Description .....	7
3.2.1 Setting the Resolution .....	7
3.2.2 Setting Positive Direction for Counter .....	8
3.2.3 Toggle Between R/D Display Mode .....	8
3.2.4 Setting Z axis Dial .....	8
3.2.5 Setting the Rotary Radius of the Workpiece.....	9
3.2.6 Setting the Angle Display Mode .....	9
3.2.7 Setting the Baudrate of RS_232(optional) .....	9
3.2.8 Setting the Absolute Zeroing enable or disable .....	10
3.2.9 Setting the Absolute form the Special Function .....	10
3.2.10 Setting the Calculator display Mode.....	10
3.2.11 display brightness setting .....	10
3.2.12 The linear scale counting frequency setting .....	11
3.2.13 Setting QUIT .....	11
3.2.14 Setting the type of the DRO. ....	11
3.2.15 Signal Interface Type .....	11
3.2.16 Restore Factory Settings: .....	12
3.2.17 Shrinkage Ratio enable or disable.....	12
3.2.18 Setting Compensation Type .....	12
3.2.19 Inch display, set the number of digits after the decimal point...	13
3.2.20 Setting EDM(optional) .....	13
3.2.21 Setting Linearity Compensation. ....	13
3.2.22 Setting the Shrinkage Ratio .....	13
4. General Operations .....	14
4.1 Zeroing.....	14
4.2 Preset Data to Designated Axis .....	14
4.3 Toggle Display Unit between inch and mm .....	14
4.4 Absolute/Incremental/200 groups SDM .....	15
4.5 1/2 Function .....	15
4.6 Clear All SDM Datum.....	16

# Contents

---

4.7 Sleeping Mode .....	16
4.8 Power Interruption Memory .....	16
4.9 Search the Absolute Reference Point of Scale .....	17
4.10 Non Linear Error Compensation .....	20
5、200 Groups SDM coordinate .....	21
5.1 Zeroing at the Current Point.....	21
5.2 Preset datum of SDM coordinate .....	22
6、Special Function.....	24
6.1 Circumference Holes Processing .....	25
6.2 Linear Holes Processing .....	28
6.3 ARC Processing .....	30
6.4 Oblique Processing .....	39
6.5 Slope Processng.....	43
6.6 Chamber Processing.....	44
6.7 The Tool Diameter Compensation Function .....	45
6.8 Digital Filter of the Grinding Machine .....	46
6.9 Lathe Function .....	47
6.9.1 200 sets TOOL Libs .....	47
6.9.2 Taper Function .....	48
6.9.3 R/D Function .....	49
6.9.4 Y + Z Function ( only applicable to : 3 axes Lathe).....	49
6.10 EDM.....	50
7、Calculator.....	56
8、Appendix .....	57

# Illustration of Panel and keyboard

## THREE AXIS PANEL

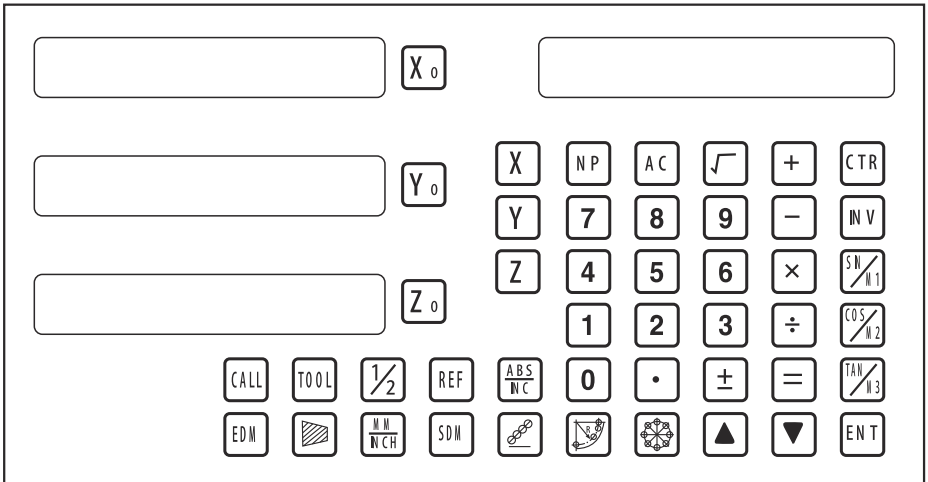



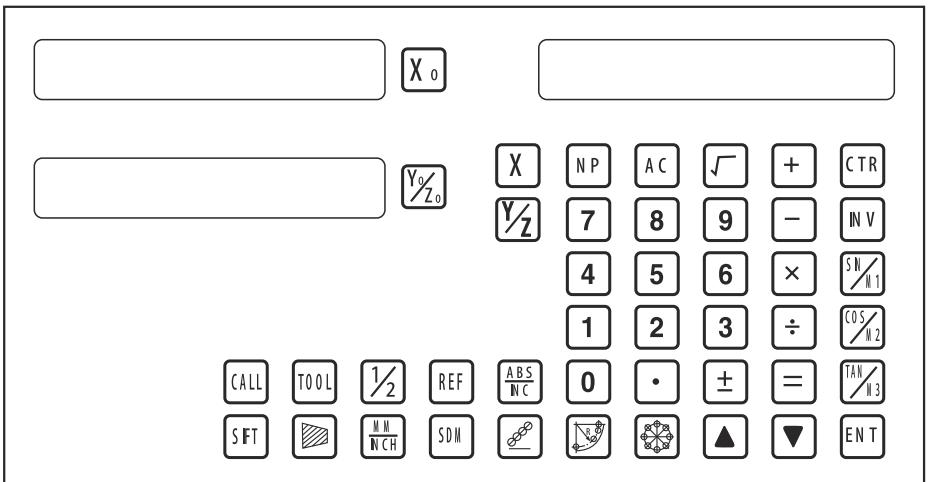































## TWO AXIS PANEL















## Caption of the keyboard

### Keyboard Description



  	Keys for axis selection
  	Zero select axis
	Enter +/- sign
	Enter decimal point
         	Entry keys for numbers
    	Operation key (in Calculation function key)
	Enter or quit calculating state
	Cancel incorrect operation
	Calculate inverse trigonometric
	Square root
	Confirm operation
	Toggles between inch and millimeter units.
	Press when ready to identify a reference mark.
	Function keys for 200 sub datum
	ARC cutting function
	holes displayed equally on a circle
	holes displayed equally on a line





## Caption of the keyboard

	Calculate trigonometric or Slope Processing function key
	Calculate trigonometric or rectangular inner chamber processing function key
	Calculate trigonometric or the tool diameter compensation function key
	Toggle between ABS/INC coordinate
	Stroll up or down to select
	Taper measured function key
	Tool library call key
	Opens the tool table.( lathe)
	EDM function key
	Filter display function key
	Half a display value of an axis
	Non Linear Error Compensation function keys

### 3、Parameters settings

#### 3.1 Parameters setup routine entrance.

Press  to enter initial system and self-check after DRO powers on in 1 second, then Parameters settings display in the Parameters window.press   to select the item you want to change.

If you want to quit initial setting, press   until “QUIT” appears in message window and press . You can also press  to quit initial setting.

#### 3.2 Parameters Settings Description



##### 3.2.1 Setting the Resolution

Press   until “RESOLUTE” appears in message window;

When selecting the LINEAR encode, the resolution will be set as follow:

There are 19 types of resolution:

0.01um;0.02um;0.05um;0.10um;0.20um;0.25um;0.50um;1.00um;  
2.00um;2.50um;5.00um;10.00um;20.00um;25.00um;50.00um;  
100.00um;200.00um;250.00um;500.00um.

Press  to change the resolution for X axis;Press  to change the resolution for Y axis;Press  to change the resolution for Z axis;

Set the resolution 5.00um to 1.00um for X axis:

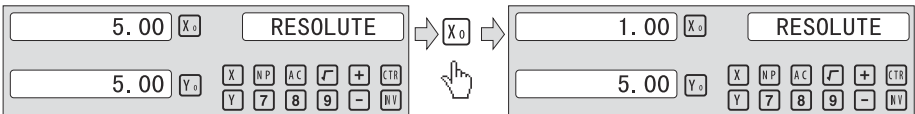

When selecting the rotary encode, the resolution will be set as follow:

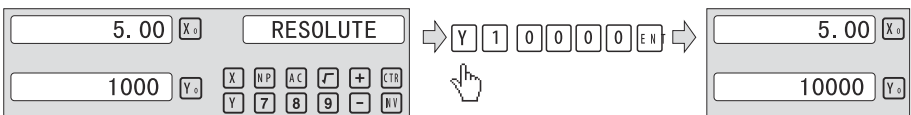

Input the rotary encode parameter value .



### 3.2.2 Setting Positive Direction for Counter

Press   until “DIRECTE” appears in message window.

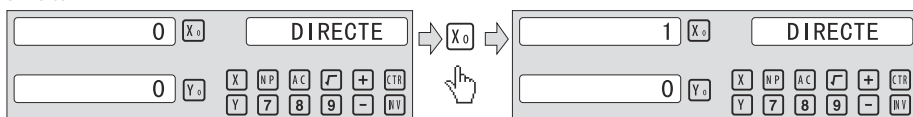

Direction ‘0’ means the display value will increase when scale moves from right to left and decrease when scale moves from left to right. Direction ‘1’ means the display value will increase when scale moves from left to right and decrease when scale moves from right to left.

Press  to change the Direction for X axis; Press  to change the Direction for Y axis; Press  to change the Direction for Z axis; as follow:



### 3.2.3 Toggle Between R/D Display Mode

Press   until “R OR D” appears in message window. X window, Y window, Z window displays ‘0’ or ‘1’ separately.

‘0’ is mode R, which means the display value equals the actual measurement. ‘1’ is mode D where the display value equals the double actual measurement. Press  to change the R/D for X axis; Press  to change the R/D for Y axis; Press  to change the R/D for Z axis; as follow:

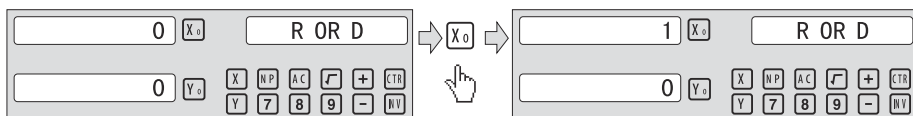

### 3.2.4 Setting Z axis Dial

Press   until “Z DIAL” appears in message window.

Z axis dial should be set if Z axis is emulated for 2 axis milling and only install linear scale for X,Y axis. Z axis dial means the distance the Z axis travels when screw runs a revolution.

## Parameters settings

Set the Z axis Dial 2.5mm as follow ;

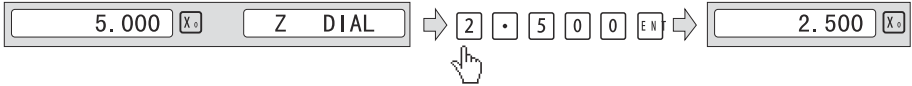

### 3.2.5 Setting the Rotary Radius of the Workpiece

Press until “RDIUS” appears in message window.

The Rotary radius type is used perimeter to measure angle.

Input the Rotary Radius parameter value 2000mm as follow:

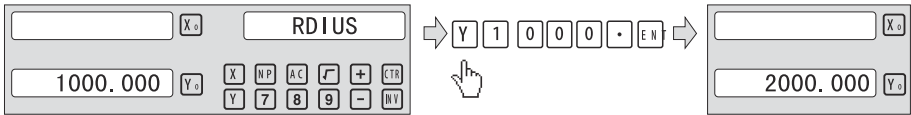

### 3.2.6 Setting the Angle Display Mode

Press until “ANG DISP” appears in message window.

Press to change the angle display mode for X axis; Press to change the angle display mode for Y axis; Press to change the angle display mode for Z axis; Example for X axis:

“0.0000” means the angle mode is Circulating DD;

“0000.0000” means the angle mode is Incremental DD;

“0.00.00” means the angle mode is Circulating DMS;

“0000.00.00” means the angle mode is Incremental DMS;

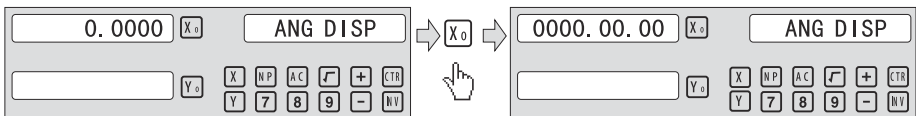

### 3.2.7 Setting the Baudrate of RS\_232 (Special customization function, if you need to buy, please contact the dealer to customize)

Press until “BAUDRATE” appears in message window.

Set the Baudrate 115200 as follow ;

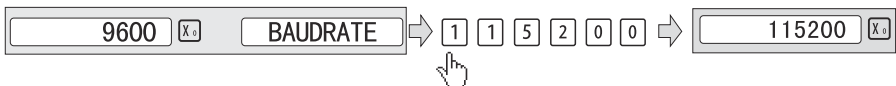

### 3.2.8 Setting the Absolute Zeroing enable or disable

Press until “ABS\_ZERO” appears in the message window.

‘0’ means operation the ABS zeroing and preset data will be enable in the normal display state.

‘1’ means operation the ABS zeroing and preset data will be disable in the normal display state.

Press to change the absolute zeroing mode for X axis; Press to change the absolute zeroing mode for Y axis; Press to change the absolute zeroing mode for Z axis; Example for X axis:

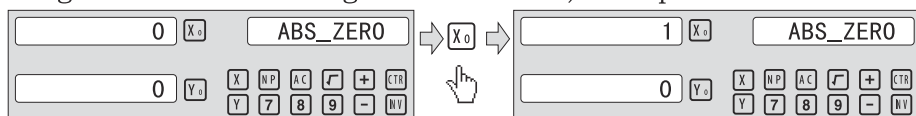

### 3.2.9 Setting the Absolute form the Special Function

Press until “ABS\_ASST” appears in message window.

‘0’ means only special function position value is display in the Special Function operation.

‘1’ means special function position value + ABS position value is display in the Special Function operation.

Press to change the absolute mode for the Special Function will be set as follow:

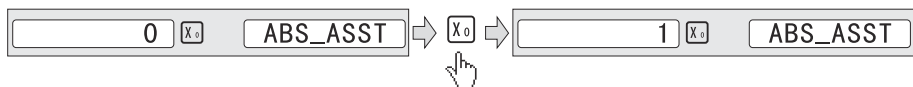

### 3.2.10 Setting the Calculator display Mode

Press until “CTR\_MODE” appears in message window.

‘0’ means the calculator display value at the X window in the disply;

‘1’ means the calculator display value at the message window in the disply;

Press to change the calculator display mode will be set as follow:

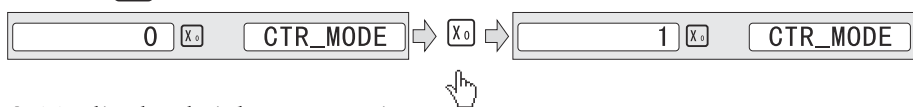

### 3.2.11 display brightness setting

LED display brightness setting, the factory default setting is only "3", the higher the parameter, the brighter the brightness. Press "X0" to set, it is not recommended that you set the default value yourself.

### 3.2.12 The linear scale counting frequency setting

The factory default setting is only "12", the higher the parameter, the lower the counting frequency, press "X0" to set, it is not recommended that you set the default value yourself.

### 3.2.13 Setting QUIT: Digital display table parameters quit button.

### 3.2.14 Setting the type of the DRO.

The type of the DRO will be display on the right window. then press the key **ENT** to select the correct type. the following system item will be set:

“MILL-3” means the DRO type is 3-axis milling machine table;

“MILL-2” means the DRO type is 2-axis milling machine table;

“LATHE-2” means the DRO type is 2-axis lathe table;

“LATHE-3” means the DRO type is 3-axis lathe table;

“GRIND” means the DRO type is Grind table;

“EDM” means the DRO type is EDM table; (Special customization function, if you need to buy, please contact the dealer to customize)

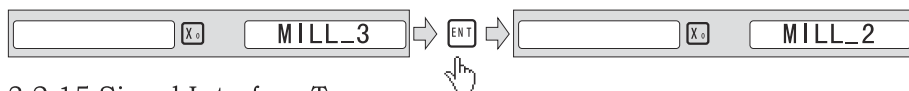

### 3.2.15 Signal Interface Type

Message window displays “SEL AXIS” which indicates the step is to Sensor input signal mode. Press **X0** to change the signal mode for X axis; Press **Y0** to change the signal mode for Y axis; Press **Z0** to change the signal mode for Z axis; Example for X axis:

Press **X0** to scroll through the Rotary encode type, the Linear encode type, the Rotary rdius type.

X window displays the Signal type.

“LInER” means the Signal type is linear encode type ;

“EnCoDE “ means the Signal type is Rotary encode type;

“RdIUS” means the Signal type is Rotary rdius type ;

Example: currently in the linear encode type, to toggle to the Rotary encode type;

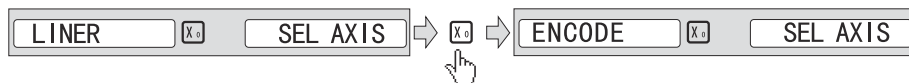

### 3.2.16 Restore Factory Settings:

Clear all data except DRO type.DRO will load default setup for parameter.After loading default setup,user must search RI once to enable resuming ABS dadum function;otherwise to resume the datum by RI is unable;

Message window displays “ALL CLR” , press **ENT** and message windows display “PASSWORD” indicating the operator to input password; Press 2000 + **ENT** in turn to load default value;

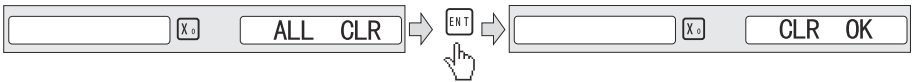

### 3.2.17 Shrinkage Ratio enable or disable.

Message window displays “SRK OFF” to disable Shrinkage rate function. Press **ENT** to enable Shrinkage rate function in Message window displays “SRK ON” :

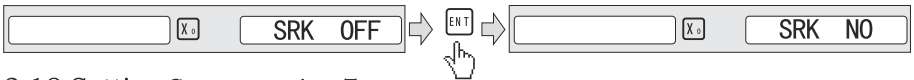

### 3.2.18 Setting Compensation Type

Message window displays “SEL COMP” which indicates the step is to compensation type. Press **X0** to change the compensation type for X axis;Press **Y0** to change the compensation type for Y axis;Press **Z0** to change the compensation type for Z axis;Example for X axis:

Press **X0** to scroll through the not compensation type, the Linear compensation type, the non-linear compensation type.

“no-CO” means the compensation type is not compensation type;

“LnE-CO” means the compensation type is linear compensation type.

“non-LinE” means the compensation type is non-linear linear compensation type;

Example for X axis: currently in the not compensation type, to toggle to the linear compensation type;

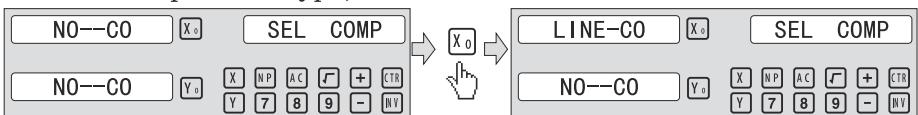

3.2.19 Inch display, set the number of digits after the decimal point

In the inch display mode, the number of digits after the decimal point is set, the factory default digit is "4", press "X0" to set, can be set according to actual needs.

3.2.20 Setting EDM: it is not recommended that you set the default value yourself, EDM function, Set the relay off on time.

3.2.21 Setting Linearity Compensation.

Message window displays “ LIN COMP” which indicates the step is to Linearity Compensation. Compensate the linear error to make display value equals to standard value.

The calculation of compensation rectifying coefficient:

$$\text{Coefficient} = \frac{(\text{Measurement} - \text{Standard value}) \times 1000.000}{\text{Standard value}}$$

Example for X axis:

Measurement 200.020mm

Standard value 200.000mm

Rectifying coefficient= (200.020-200) \* 1000 /200 =-0.01mm/m

Input compensation rectifying coefficient 0.01 as follow:

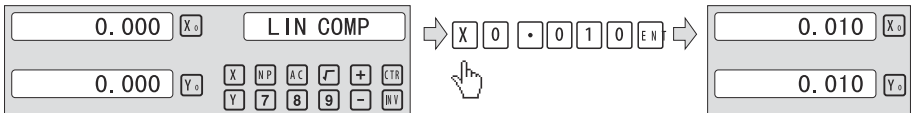

3.2.22 Setting the Shrinkage Ratio

Press ▲ ▼ until “ SHRINK” appears in message window;

$$\text{Shrinkage ratio} = \frac{\text{Dimensions of the finished product}}{\text{Dimensions of the working piece}}$$



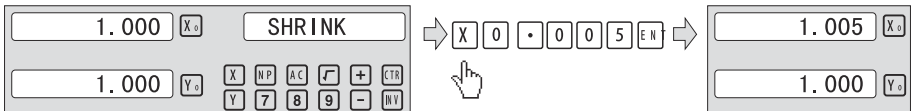



Set the shrinkage ratio 1.005 as follow;







4、General Operations;

4.1 Zeroing

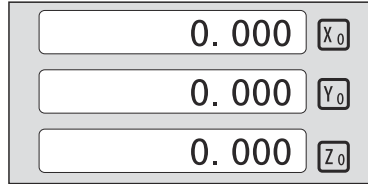
Zero the designated axis in normal display state. Zeroing is used to set the current point as datum point as follow;

- key    $\Rightarrow$  X axis zero
- key    $\Rightarrow$  Y axis zero
- key    $\Rightarrow$  Z axis zero



 or  or  will be return to the original data before the reset.

4.2 Preset Data to Designated Axis

Preset a value to current position for a designated axis in normal display state.

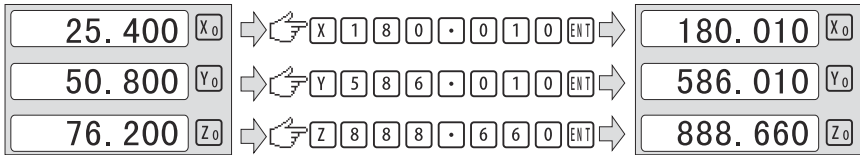

4.3 Toggle Display Unit between inch and mm

Length can be displayed either in “mm” (metric) or “inch” (imperial). Display unit can be toggled between mm and inch.

Example: Display value toggle from mm to inch;

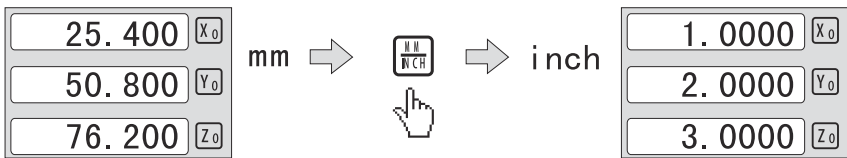

Example: Display value toggle from inch to mm;

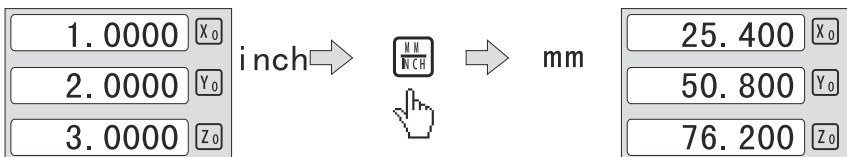

## 4.4 Absolute/Incremental/200 groups SDM

Function: The DRO has 3 coordinate display modes: the absolute mode (ABS); the incremental mode (INC) and 200 groups Second Data Memory (SDM) with the range of 00 to 99. Zero point of work-piece is set at the origin point of ABS coordinate. The relative distance between datum of ABS and SDM remains unchanged when ABS datum is changed.

1. Toggle from ABS to INC coordinate;

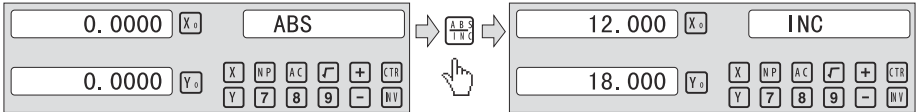

2. Toggle from INC to ABS coordinate;

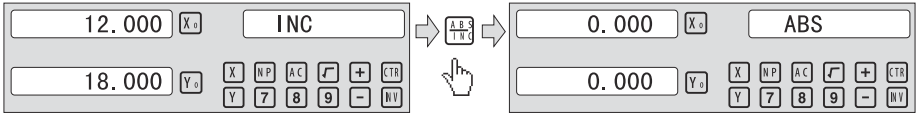

3. Toggle from SMD to ABS coordinate;

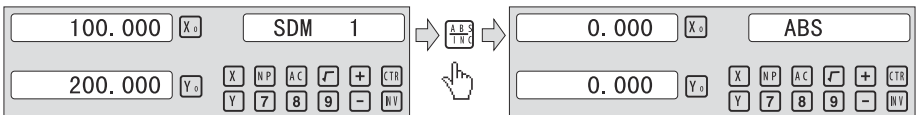

## 4.5 1/2 Function

Function: Set the center of work piece as datum by halving the displayed value.

Example: Set the center of rectangle as datum as the right figure.

Steps:

1、Touch one side of the workpiece with the TOOL, then zero the X axis.

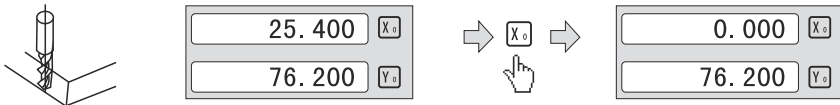

2、 Take the TOOL to the opposite side of the workpiece and touch it. Then press **X** + **1/2** in turn to value the X axis display value.

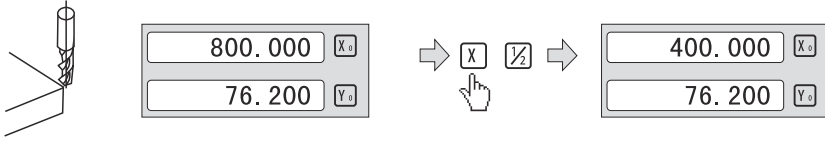

3、 Move the machining table until “0.000” is display in X axis window. The position is the work-piece’ s center.

#### 4.6 Clear All SDM datum.

In ABS mode, to continuously press **•** ten times will cause to clear all the datum for 200 sets SDM. Message window displays “SDM CLR” .

#### 4.7 Sleeping Mode

In not ABS Mode, pressing the key **REF** can turn off all the display and the DRO accessing to the Sleeping Mode, then pressing this key again will cause the DRO back to the working Mode. In the Sleeping Mode the DRO is still in working state and actually records the TOOL movement.

Example: In not ABS Mode, to access the sleeping Mode by pressing the key **REF** . In Sleeping Mode, pressing the key **REF** to quit the sleeping Mode.

#### 4.8 Power Interruption Memory.

The memory is used to store the settings of the DRO and machine reference values when power is turn off.

### 4.9 Search the Absolute Reference Point of Scale

During the daily machining process, it is very common that the machining cannot be completed within one work shift, and hence the DRO have to be switched off after work, or power failure happen during the machining process which is leading to lost of the workpiece datum (workpiece zero position), the re-establishment of workpiece datum using edge finder or other method is inevitably induce higher machining in accuracy because it is not possible to re-establish the workpiece datum exactly at the previous position. To allow the recovery of workpiece datum very accurately and no need to re-establish the workpiece datum using edge finder or other methods, every Linear scale have a ref point location which is equipped with ref position to provide datum point memory function.

The working principal of the ref datum memory function are as follows.

Since the ref point of Linear scale is permanent and fixed, it will never change or disappear when the DRO system is switched off. Therefore, we simply need to store the distance between the ref point and the workpiece datum (zero position) in NON-Volatile memory. Then in case of the power failure or DRO being switched off, we can recover the workpiece datum (zero position) by presetting the display zero position as the stored distance from the ref point.

An absolute datum should be set when a work-piece is machined. There are three mode operation (REF、AB、LEF\_AB):

Example: to store the X axis work datum.

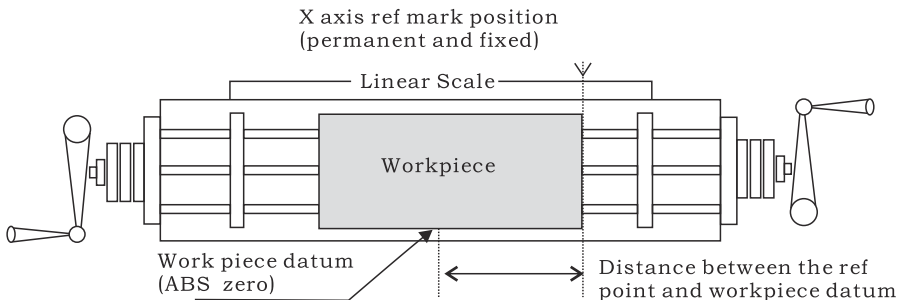

**Example for REF mode :**

1、DRO is set in ABS coordinate. Press **REF** , then the message window display “REF” .

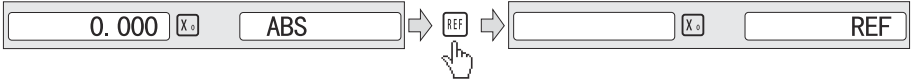

2、Message window displays “REF” , Press **ENT** until “FD\_REF” appears in message window.

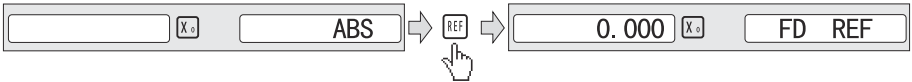

3、Select the axis which need search RI. For instance : select X axis, then press **X** . “X\_REF” is displayed in message window, and X axis window flashes.

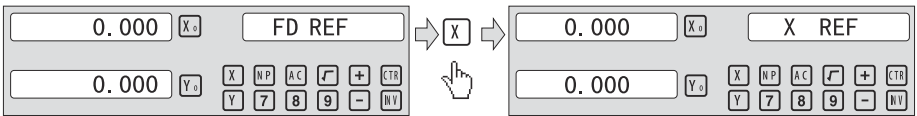

4、Move the machine table .The buzzer sounds when RI is searched, then X window stops flashing and displays the value of the current position .the DRO returns normal display state. Then message window displays “FIND\_X” .

**Example for AB mode :**

1、DRO is set in ABS coordinate. Press **REF** , then the message window display “REF” .

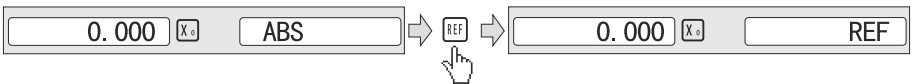

2、Press **▲ ▼** , then the message window display “AB” .

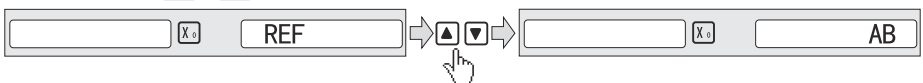

3、Message window displays “AB” , Press **ENT** until “FIND\_AB” appears in message window.

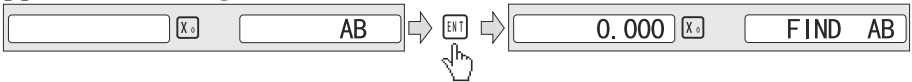

4、 Select the axis which need search RI. For instance : selct X axis, then press **X** . “X\_REF” is displayed in message window, and X axis window flashes.

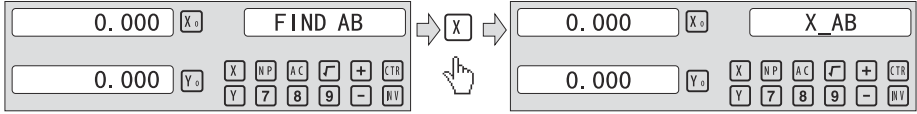

5、 Move the machine table .The buzzer sounds when RI is searched, displays the value of the current position for the absolute datum zero. the DRO returns normal display state. Then message window displays “FIND\_AB” .

**Example for LEF\_AB mode :**

1、 DRO is set in ABS coordinate. Press **REF** , then the message window display “REF” .

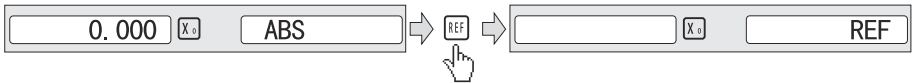

2、 Press **▲ ▼** , then the message window display “AB” .



3、 Message window displays “LEF\_AB” , Press **ENT** until “ZERO\_AB” appears in message window.

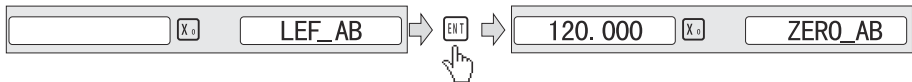

4、 Move the machine table to be set zero position piont. then press **X** , X axis will be zeroing . the current position for the absolute datum zero. the DRO returns normal display state.

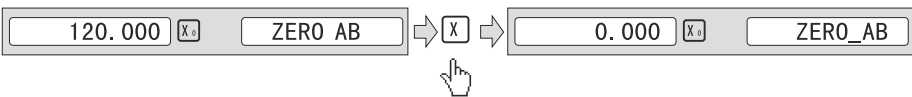

**NOTE: Linear range without reference point location of the user**

#### 4.10 Non Linear Error Compensation

First compensation Type ( Linear or Non-Linear) in parameter setting must be set Non-Linear. Linear scale have a ref point location and find to the Absolute Reference Point will be enable.

Default Non-Linear compensation : 50.

#### Example for Y axis:

Step 1: Search the Absolute Reference Point of Scale;

Step 2: Press **[NP]** , then the message window display “COMP X” .



Step 3: Press **[▲]** **[▼]**, then the message window display “COMP Y”



Step 4: Press **[ENT]**, then the message window display “NUMBER” .

Then input the compensation parameter NUMBER.



Step 5: Press **[▲]** **[▼]**, then message window displays “Y-MSN-1” which indicates the step is to Non Linear Error Compensation.

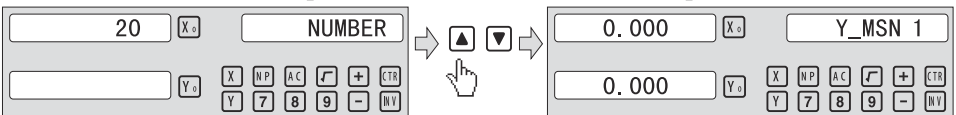

Step 6: Input compensation value .

X window display the value of the measurement value.

Y window display the value of the standard value.

Example for the first compensation point:

Measurement value :68.288mm. Standard value: 68.200mm

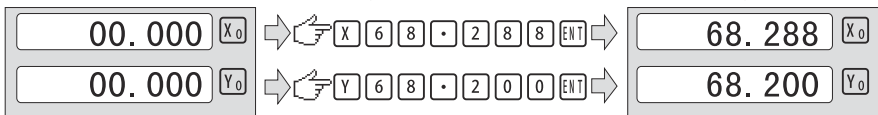

Step 7: After input all parameter, the DRO automatically exit.

## 5、 200 Groups SDM coordinate

The DRO has three display modes: the absolute mode (ABS), the incremental mode (INC) and the 200 groups second data memory (SDM 1 – SDM200). ABS datum of the work-piece is set at the beginning and the 200 groups SDM is set relative to ABS coordinate.

ABS Mode, INC Mode and SdM Mode are specially designed to provide much more convenience features to the operator to cope with the batch machining of relative works and the machining of the workpiece machining dimensions from more than one datum.

**Example:** The ABS datum is the center point O, the point sdm1, sdm2, sdm3, sdm4 needed processing are set as datum of SDM 1 – SDM 4.

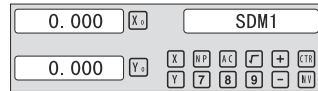
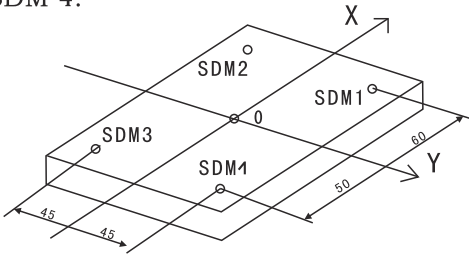

Two ways to set SDM coordinate:

- 1、 Zeroing at the Current Point.
- 2、 Preset datum of SDM coordinate.

### 5.1 Zeroing at the Current Point

At first set the center point of the work-piece as the origin of the ABS, then align the TOOL with point SDM1,SDM2,SDM3,SDM4 by moving the machine table and zero them. It is the position to process where the “0.000” appears in X window, Y window by moving the machine table whether in ABS or in SDM coordinate.

#### Steps:

- 1、 Move worktable to place the TOOL at the center of the workpiece point O as the datum of ABS. Then zero X axis and Y axis in SDM 1 ; Zero X axis and Y axis in SDM 2 ; Zero X axis and Y axis in SDM 3 ; Zero X axis and Y axis in SDM 4.

2、 Set the point sdm1 as the datum of SDM 1. Move the machine worktable to  $x = 60.000$ ,  $y = 45.000$ . Then proess  $X_0$   $Y_0$ .

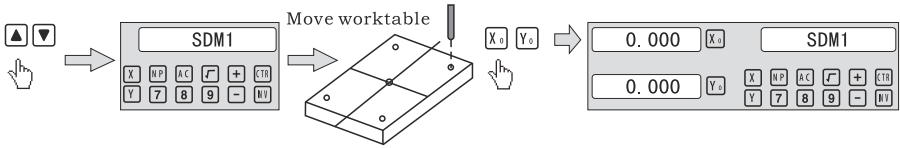

2、 Set the point sdm1 as the datum of SDM 2. Move the machine worktable to  $x = 60.000$ ,  $y = -45.000$ . Then proess  $X_0$   $Y_0$ .

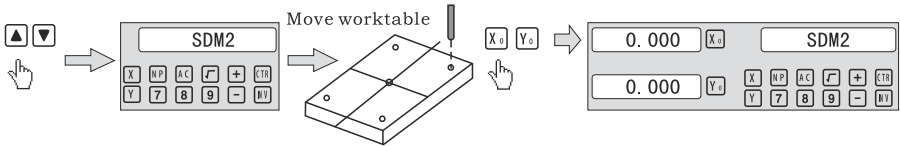

3、 Set the point sdm1 as the datum of SDM 3. Move the machine worktable to  $x = -60.000$ ,  $y = -45.000$ . Then proess  $X_0$   $Y_0$ .

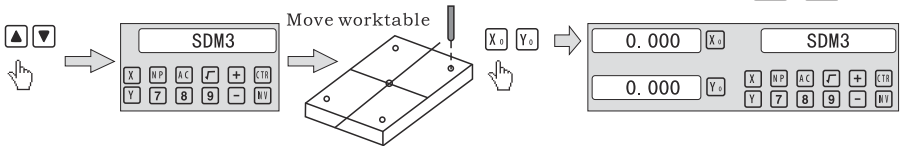

4、 Set the point sdm1 as the datum of SDM 4. Move the machine worktable to  $x = -60.000$ ,  $y = 45.000$ . Then proess  $X_0$   $Y_0$ .

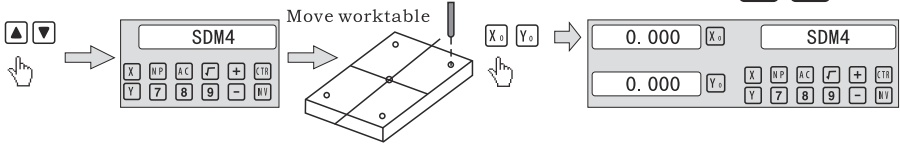



## 5.2 Preset datum of SDM coordinate



There are the same sample as Method 1. First Move the worktable to place the TOOL exactly at the origin of ABS, secondly Enter the ABS Mode as follow.

### Steps:



1、 Move worktable to place the TOOL at the center of the workpiece point O as the datum of ABS. Then zero X axis and Y axis in SDM 1 ; Zero X axis and Y axis in SDM 2 ; Zero X axis and Y axis in SDM 3 ; Zero X axis and Y axis in SDM 4.

2、Set point sdm1 as the datum of SDM 1. Press  , then the message window display “SDM 1” . Input x = 60.000, y = 45.000.





3、Set point sdm1 as the datum of SDM 2. Press  , then the message window display “SDM 2” . Input x = -60.000, y = 45.000.



4、Set point sdm1 as the datum of SDM 3. Press  , then the message window display “SDM 3” . Input x = -60.000, y = -45.000.



5、Set point sdm1 as the datum of SDM 4. Press  , then the message window display “SDM 4” . Input x = -60.000, y = 45.000.



## 6、 Special Function

### 6.1 Circumference Holes Processing

The Function of PCD Hole positioning on Circumference is used to distribute arc equally, such as boring hole on flange. The right window will show the parameter to be defined when selecting PCD Function.

The Parameters to be defined are:

PCD_XY(XZ,YZ)	Select place
CENTER	Center position
DIA	Diameter of circle
NO_HOLE	Hole number
ST ANG	Starting angle
ED ANG	Ending angle

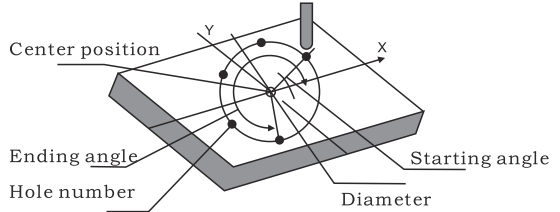

The position of the hole center are calculated automatically after input all parameters. Press or to choose the hole No. and move the machine table until the “0.000” appears in X window , Y window, Z window. It is the position to process a table.

Example for the XY place: Machine hole on circumference as the figure

PCD_XY(XZ,YZ)	XY
CENTER	X=0,000,Y=0.000
DIA	100,000
NO_HOLE	5
ST ANG	30,000
ED ANG	315,000

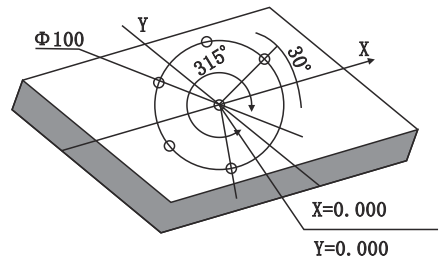

Steps:

1. Set display unit to metric in normal state; Move the machine table until the machine TOOL is aligned with the center of the circle , then zero X axis ,Y axis.

2. Select place.

Press , then the message window display “PCD\_XY” to the Circumference Holes Processing. Press or to select XY place.



2. Input center position.

Press **ENT** , then the message window display “CENTER” . X and Y window displays the formerly preset center position. Input X = 0, Y = 0 as follow.

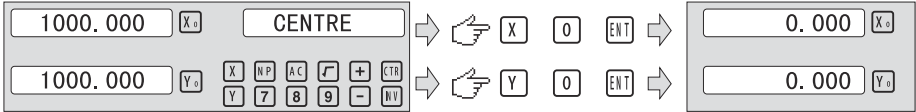

4. Input diameter.

Press **▼** until “DIA” appears in the message window. X window displays the formerly preset diameter. Then input the diameter is 100.000.

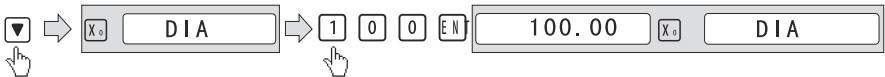

5. Input number.

Press **▼** until “NO\_HOLE” appears in the message window. X window displays the formerly preset number. Then press **5** in turn to input number.

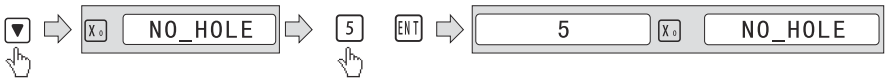

6. Input starting angle.

Press **▼** until “ST ANG” appears in the message window. X window displays the formerly preset the starting angle. Then press **3** **0** in turn to input the starting angle.

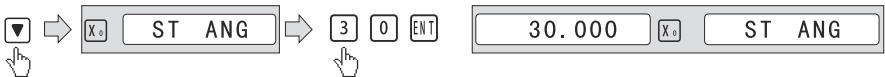

7. Input ending angle.

Press **▼** until “ED ANG” appears in the message window. X window displays the formerly preset the ending angle.. Then press **3** **1** **5** in turn to input the ending angle.

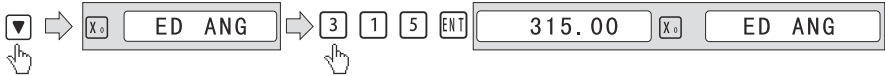

8. Press  until “NO 1” appears in the message window.

It is the position of the first hole to punch where the “0.000” is displayed in X window and Y window by moving the machine table.

After finishing the first hole, press  or  to change holes number.

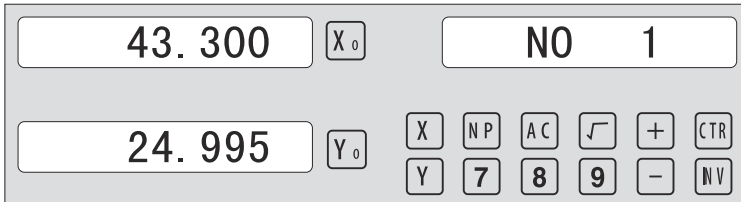

9. After processing all holes, press  to return normal display.

### 6.2 Linear Holes Processing

There are two modes to carry out the linear drilling: Length mode and Step mode.

- 1.LINE S Step mode
- LINE L Length mode
- 2.STEP Step length
- LENGTH Line length
- 3. ANG Angle
- 4. NO.HOLE Hole number

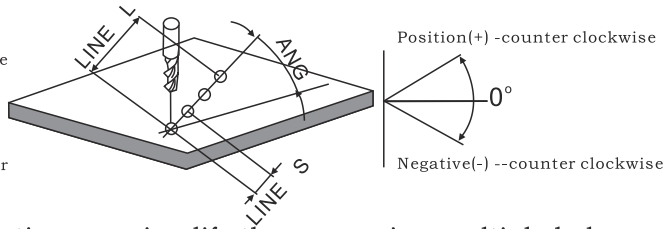

Linear Holes function can simplify the processing multiple holes whose centers are attributed equally on one line.

Example :

- LINE\_L Length mode
- LENGTH 60.000
- ANG 30.000
- NO.HOLE 4

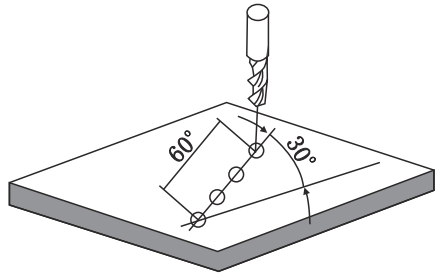

Steps :

1. Select piece.

Press , then the message window display “LINE\_XY” to the Linear Holes Processing. Press or to select XY place.

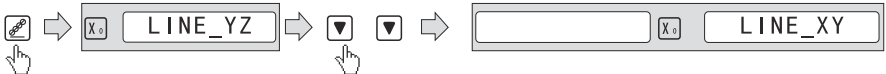

2. Select Linear Holes mode.

Press , then the message window display “LINE\_S” . Press or to select “LINE\_L” .

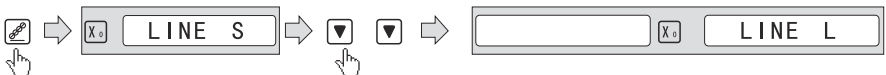

3. Input linear length;

Press , then the message window display “LENGTH” .

X window displays the formerly preset the linear length. Press **6** **0** in turn to input the linear length.

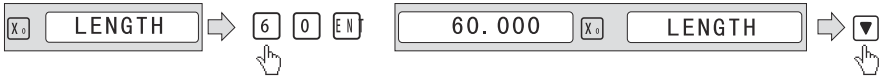

4. Input angle;

Message window displays “ANG” which indicates the step is to angle. X window displays the formerly preset the angle. Press **3** **0** in turn to input the angle.

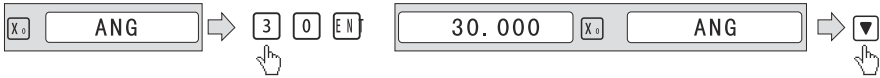

5. Input number;

Message window displays “ANG” which indicates the step is to angle. X window displays the formerly preset the number. Press **4** in turn to input the number.

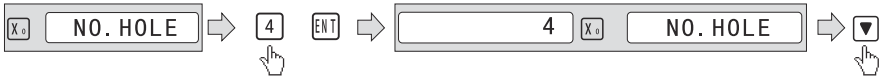

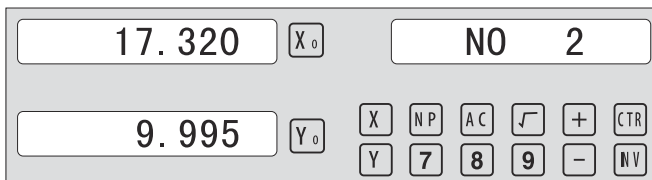

6. Press **▼** until “NO 1” appears in the message window.

It is the position of the first hole to punch where the “0.000” is displayed in X window and Y window by moving the machine table. After finishing the first hole, press **▲** or **▼** to change holes number.



7. After processing all holes, press **🔗** to return normal display.

## 6.3 ARC Processing

Two functions are available for the ARC function: the simple ARC Function and the smooth R function. Press  to enter ARC function, then press  or  for selecting smooth ARC function or Simple ARC Function.

During installation, normally the coordinate of the machine and the direction of X, Y, Z are as per follow. The work plane is shown as the right figure.

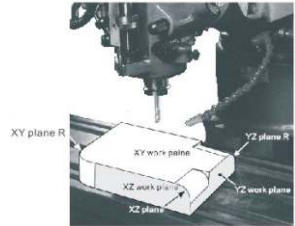
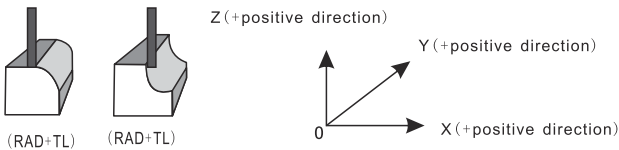

### Simple ARC Function:

When the smoothness is not highly demanded, the SIMPLE ARC function is normally used for machining arc. In the SIMPLE function there are only eight type of ARC used to machine. The operator just select the type of R and input the parameters of the radius of Arc, MAX CUT and outer arc or inner arc. In general, an arc may be machined by a planar slot TOOL or arc TOOL, the different between them in different work plane as shown as per follows.

- |                 |                         |
|-----------------|-------------------------|
| 1、SIMPLE        | Simple processing       |
| 2、TYPE 1-8      | Mode of the ARC.        |
| 3、SEL_XY(XZ,YZ) | Select place            |
| 4、RAD           | Arc radius              |
| 5、TL DIA        | Tool diameter           |
| 6、MAX CUT       | Feed step               |
| 7、RAD_TL        | Outer arc and inner arc |
|                 | (only for XY place)     |

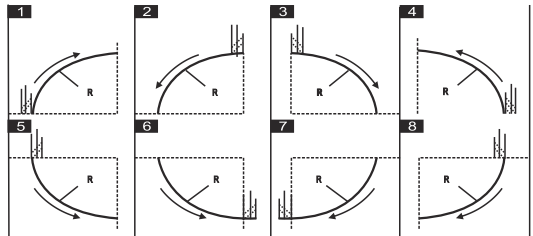

Smooth ARC function :

Provides maximum flexibility in ARC machining, the ARC sector to be machined by the coordinates of ARC. Very flexible, ARC function can machine virtually all kinds of ARC, ever the intersected ARC. Relatively a bit complicated to operate, operator need to calculate and enter the coordinates of ARC centre, start angle and end angle.

Basic parameter as follow:

- |                   |                                     |
|-------------------|-------------------------------------|
| 1. SMOOTH         | Mode of the Smooth ARC processing;  |
| 2. SEL_XY(YZ, XZ) | Select place;                       |
| 3. CENTER         | Refer to the position of an center. |
| 4. RAD            | Radius of the ARC                   |
| 5. TL_DIA         | Diameter of the TOOL                |
| 6. MAX_CUT        | Feed step                           |
| 7. ST_ANG         | Starting angle                      |
| 8. ED_ANG         | Ending angle                        |
| 9. RAD+TL         | Outer arc.                          |
| RAD-TL            | Inner arc.                          |

**Example 1 for the Simple ARC Processing:**

Parameters settings as follow:

- |         |             |
|---------|-------------|
| SIMPLE  | Simple mode |
| TYPE    | 3           |
| SEL_XY  | XY          |
| RAD     | 80.000      |
| TL_DIA  | 6.000       |
| MAX_CUT | 0.500       |
| RAD+TL  | 1           |

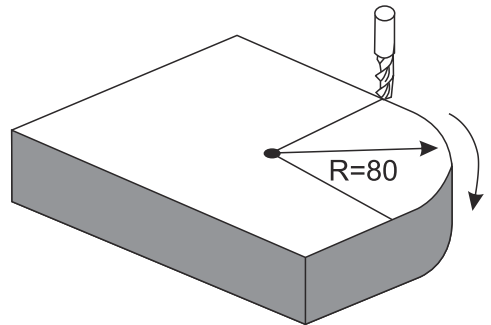

Steps:

1. Select process mode

Press  , then the message window display “SIMPLE” to the ARC Processing. Press  or  to select mode of the simple, The message window display “SIMPLE”



2. Input the type:

Press **ENT** until “TYPE” appears in the message window. X-window despalys the formerly preset the type. Press **3** in turn



3. Select place

Press **ENT** until “SEL\_XY” appears in the message window. Press **▲** or **▼** to select place to display “SEL\_XY” ;

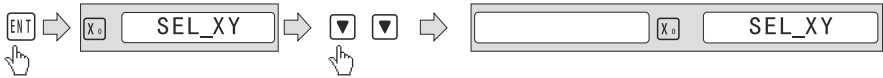

4. Input radius:

Press **ENT** until “RAD” appears in the message window. X window despalys the formerly preset the radius of ARC. Press **80** in turn to input the radius.;

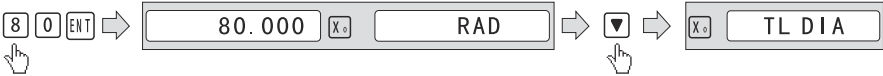

5. Input Diameter of the TOOL

Press **▲** or **▼** until “TL DIA” appears in the message window. X window despalys the formerly preset the Diameter of the TOOL. Press **6** in turn to input the Diameter value;



6. Input Feed step (MAX\_CUT);

Press **▲** or **▼** until “MAX\_CUT” appears in the message window. X window despalys the formerly preset the MAX\_CUT. Press **0.5** in turn to input the MAX\_CUT value;



7. Select outer arc or inner arc

Press or until “RAD-TL” appears in the message window. Press or to select place to display “RAD+TL” ;

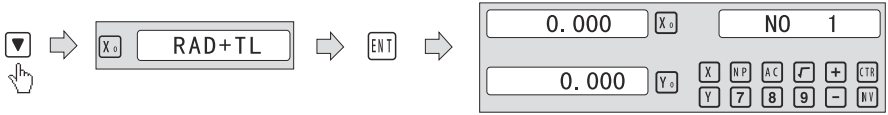

8. After inputting all parameters, press the key for machining.

The DRO will display the position of the first point. Retract the axes until the displays read 0.000, Machine the Arc point by point in accordance with the display. After finishing the position of the first point, press or to change position point.

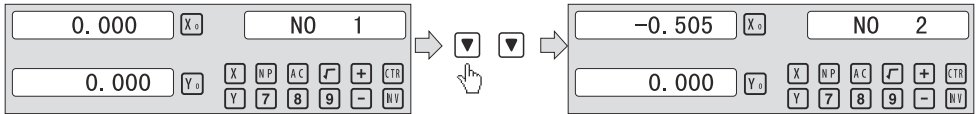

Press to quit R function any time.

**Example 2 for the Simple ARC Processing:**

Parameters settings as follow:

SIMPLE	Simple mode
TYPE	3
SEL_XY	XZ .....
RAD	80.000 .....
TL_DIA	6.000 .....
MAX_CUT	0.500 .....

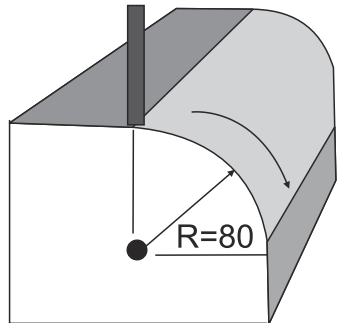

Steps:

1. Press , then the message window display “SIMPLE” to the ARC Processing. Press or to select mode of the simple, The message window display “SIMPLE”

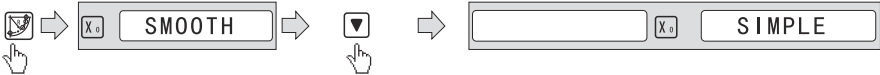

2. Input the type:

Press **ENT** until “TYPE” appears in the message window. X-window despalys the formerly preset the type. Press **3** in turn



3. Select place

Press **ENT** until “SEL\_XZ” appears in the message window.

Press **▲** or **▼** to select place to display “SEL\_XZ” ;

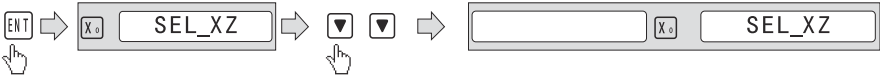

4. Input radius:

Press **ENT** until “RAD” appears in the message window. X window despalys the formerly preset the radius of ARC. Press **80** in turn to input the radius.;



5. Input Diameter of the TOOL

Press **▲** or **▼** until “TL DIA” appears in the message window. X window despalys the formerly preset the Diameter of the TOOL. Press **6** in turn to input the Diameter value;



6. Input Feed step (MAX\_CUT);

Press **▲** or **▼** until “MAX\_CUT” appears in the message window. X window despalys the formerly preset the MAX\_CUT. Press **0.5** in turn to input the MAX\_CUT value;



7. After inputting all parameters, press the key **ENT** for machining.

For 2-axis milling machine table , It is not installed with Z-axis, please press **▲** or **▼** to simulate position of Z-axis. Press **▲** simulate moving to the former process, and press **▼** simulate moving to the next process point.

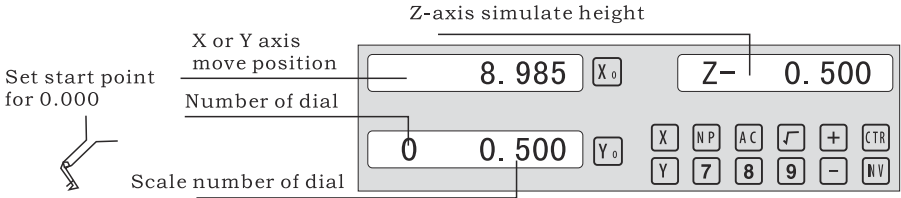

$$\text{Z-axis simulate height} = \text{Number of dial} \times \text{Z axis Dial} + \text{Scale number of dial}$$

Press **ESC** to quit R function any time.

### Example 3 for the Smooth ARC function:

Parameters settings as follow:

SMOOTH	Smooth mode
SEL_XY(YZ,XZ)	XY
CENTER	X=0,Y=0
RAD	80.000
TL_DIA	6.000
MAX_CUT	0.500
ST_ANG	0.000
ED_ANG	135.000
RAD+TL	1

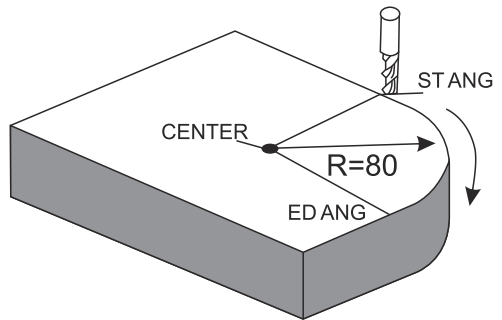

Steps:

1. Press **ESC** , then the message window display “SIMPLE” to the ARC Processing. Press **▲** or **▼** to select mode of the simple, The

message window display “SMOOTH” ; For 3-axis milling machine table without this step. In second step. Then press **ENT** .

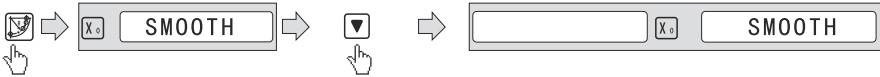

2. Select place

Message window display “SEL\_XY” which indicates the select is to place. Press **▲** or **▼** to select place to display “SEL\_XY” ;

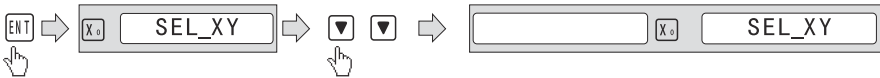

3. Input center position.

Press **ENT** , then the message window display “CENTER” . X and Y window displays the formerly preset center position. Input X = 0, Y = 0 as follow.

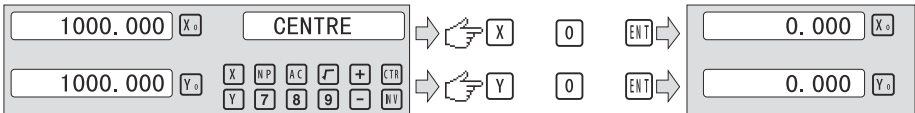

4. Input radius:

Press **ENT** until “RAD” appears in the message window. X window despalys the formerly preset the radius of ARC. Press **8** **0** in turn to input the radius.;







5. Input Diameter of the TOOL

Press **▲** or **▼** until “TL DIA” appears in the message window. X window despalys the formerly preset the Diameter of the TOOL. Press **6** in turn to input the Diameter value;



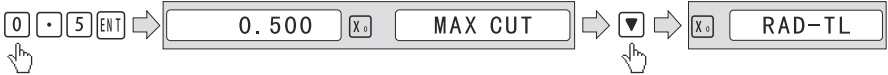

6. Input Feed step (MAX\_CUT);

Press  or  until “MAX\_CUT” appears in the message window. X window displays the formerly preset the MAX\_CUT. Press    in turn to input the MAX\_CUT value;





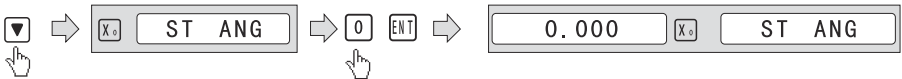

7. Input starting angle.

Press  until “ST ANG” appears in the message window. X window displays the formerly preset the starting angle. Then press  in turn to input the starting angle.





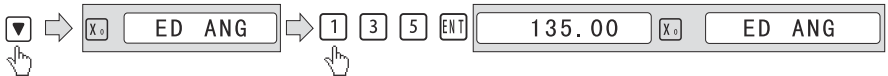

8. Input ending angle.

Press  until “ED ANG” appears in the message window. X window displays the formerly preset the ending angle.. Then press    in turn to input the ending angle.



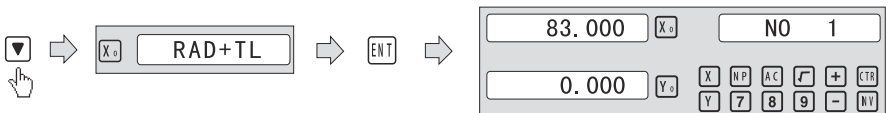

9. Select outer arc or inner arc

Press  or  until “RAD-TL” appears in the message window. Press  or  to select place to display “RAD+TL” ;



10. After inputting all parameters, machining.

The DRO will display the position of the first point. Retract the axes until the displays read 0.000, Machine the Arc point by point in accordance with the display. After finishing the position of the first point, press  or  to change position point.

# ARC Processing

---

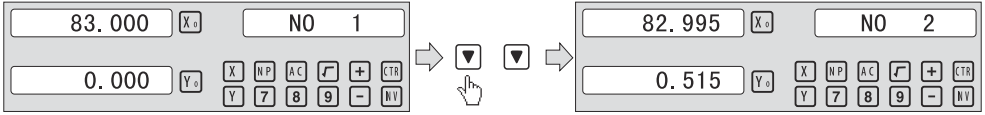

Press  to quit ARC function any time.

## 6.4 Oblique Processing

There are 2 ways available for machining oblique place:

a). on the place. b). on the place YZ, or XZ;

Only the following parameters need to be inputted:

INCL_XY(XZ,YZ)	Set machine place XY,YZ,Or XZ place.
ANG	The inclination angle of the oblique.
DIA	The TOOL Diameter.
ST_POT	Starting position;
ED_POT	Ending posting;

### **Example 1 for the Oblique XY place:**

When the machining plane is on plane XY as the part shown in Figure, the angle of obliquity of the workpiece should be calibrated before the oblique plane is machined. Therefore , at this point the machining of oblique plane plays the role of calibrating the obliquity.

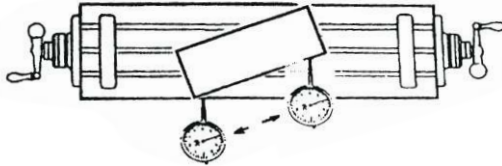

### Procedure for calibrating the obliquity



First place the workpiece on the worktable as per the required angle of obliquity.

- 1) Enter the function of oblique plane.
- 2) Select the function of plane X Y .
- 3) Input the angle of obliquity.
- 4) Move the worktable until the measuring tool (such as a dial gauge) installed on the milling machine touches the obliquity-calibrating plane, adjust it to zero, and move the worktable for any distance in the direction of X-axis.
- 5) Move the worktable in the distance of Y-Axis until the display turns to zero.

6) Change the angle of the work piece to make the workpiece touch the measuring tool and adjust it to zero.

STEPS:



1. Select place

Press , then the message window display “INCL\_XY” to the Oblique Processing. Press  or  to select place to display “SEL\_XY”;

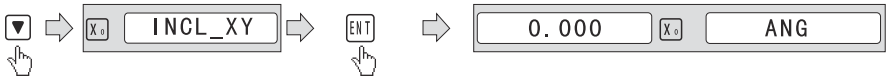
Then press  to in next step;



2. Input the angle of obliquity

The message window display “ANG” , X window displays the formerly preset the angle of obliquity. Press   in turn to input the angle of obliquity .



3. Move the workpiece along the X-Axis until the measuring tool touches the workpiece adjust it to zero, and move the worktable for any distance along the X-Axis.



4. Press , display the value of Y-Axis. Move the workpiece along the Y-Axis, change the angle of workpiece to make the obliquity-calibrating plane touch the measuring tool until it turns to zero. Move the worktable until Y-Axis is displayed as zero.

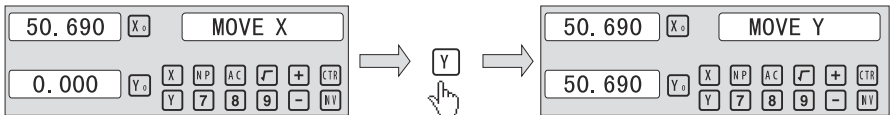

5. Press  to quit oblique function any time.

**Example 2 for the oblique XZ or YZ place:**

When the machining plane is on plane XZ or YZ, the function of TOOL inclination can instruct the operator to machine the oblique plane step by step.



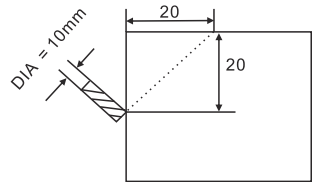
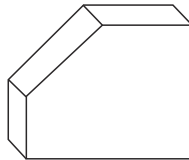

Procedures for using the function of cutter inclination:

When the machining plane is on plane XZ or YZ, first please calibrate the obliquity of the primary spindle nose and set the TOOL:

INCL_XY(XZ,YZ)	INCL_XZ
DIA	10.000
ST_POT	20.000
ED_POT	20.000



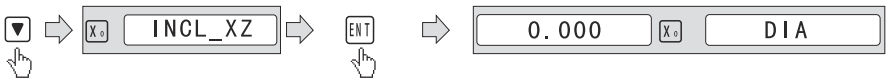

**STEPS:**

1. Press , then the message window display “INCL\_XY” to the oblique Processing. Press  or  to select place to display “SEL\_XZ; Then press  to in next step;



2. Input The TOOL Diameter

The message window display “DIA” , X window displays the formerly preset the angle of obliquity. Press   in turn to input the TOOL Diameter of obliquity . OK, then press  to in next step;



3. Input ST\_POT;

The message window display “ST\_POT” , X and Y window displays the formerly preset the stating position of obliquity. Input X= 0, Y = -20.000. OK, then press  to in next step;

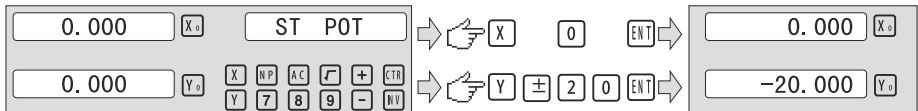

4. Input ED\_POT;

The message window display “ED\_POT” , X and Y window displays the formerly preset the starting position of obliquity. Input X= 20.000, Y = 0.000 .

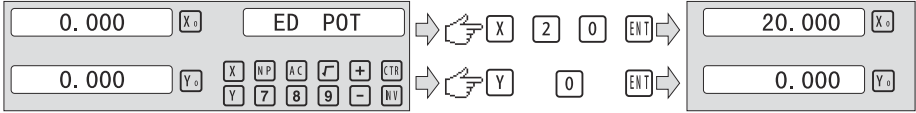

5. After input all parameter, press the key for machining.

For 2-axis milling machine table , It is not installed with Z-axis, please press or to simulate position of Z-axis. Press simulate moving to the former process, and press simulate moving to the next process point.

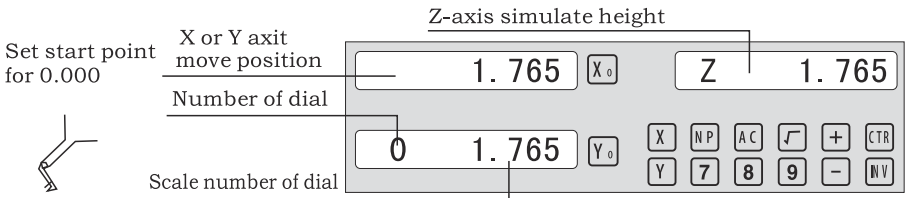

$$\text{Z-axis simulate height} = \text{Number of dial} \times \text{Z axis Dial} + \text{Scale number of dial}$$

Press to quit **oblique** function any time.

### 6.5 Slope Processing



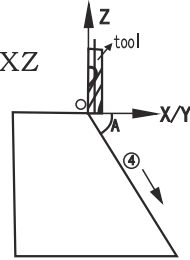

This function can calculate the position of every processing point automatically in processing slope. Only the following parameters need to be inputted:

- XZ, YZ                      Set machine place YZ, or XZ
- ANG                            The inclination angle
- Z\_STEP                        The slope length  
each time processing





#### Example 1 for the Slope XZ place;

Step 1. Select place

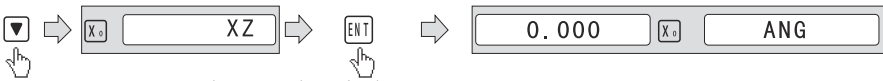
Press , then the message window display “XZ” to the slope Processing. Press  or  to select place to display “SEL\_XY; Then press  to in next step;





Step 2. Input the angle of slope

The message window display “ANG” , X window displays the formerly preset the angle of slope. Press   in turn.



Step 3. Input Z\_step;

The message window display “Z STEP” , X window displays the formerly preset the stating position of slope. Input    in turn.



Step 4:Finishing the ALL processing . Press  to quit slope function any time.

6.6 Chambering Processing

1,FLAT\_XY: machine place; 2, DIA:diameter of TOOL; 3, CENTER: center of the chambering ; 4, SIZE: size of the chambering ; Figure as follow:

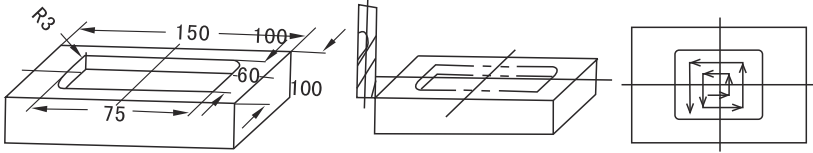

STEPS:

1. Press  , then the message window display “FLAT\_XY” to the Chambering Processing.



2. Input DIA of the TOOL;

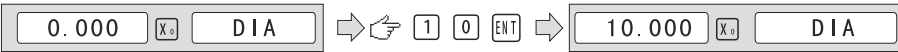



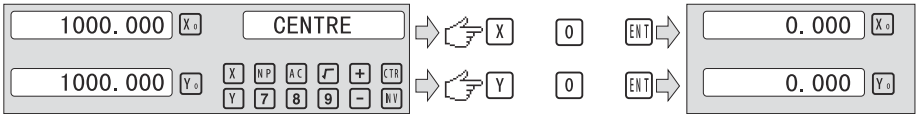

3. Input the center coordinate;

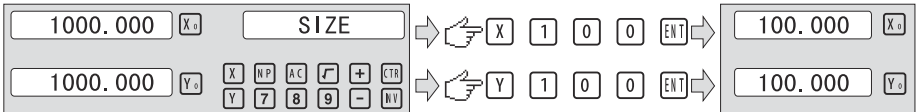

4. Input the size;



5. process Chambering;

Move the machine until the display of the axis is zero,ie, the position of the first point. Machine the first point . Display the next machining point by pressing  or  .On the completion of machining, the right window shows OVER. Press  or  , the system will goto the first position for the next workpiece. Press  to quit the Chambering Function.

## 6.7 The Tool Diameter Compensation Function



Without TOOL compensation, the operator has to move the TOOL for an additional distance of the diameter of the TOOL along each side when machining the four 150 and 100 sides of a workpiece to finish machining the whole brim. The digital readouts shall automatically compensate when the TOOL compensation function is enable.

Note: the TOOL compensation is made in the direction of X and Yaxis.

Procedures:

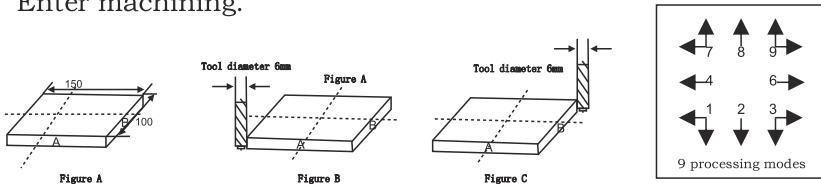
- 1) . Enter the function of compensating the diameter of the TOOL.
- 2) . Select one of the (four) preset machining modes.
- 3). Input the diameter of the TOOL.
- 4) . Enter machining.



Step1: press  to enter the TOOL compensation Function. then the message window display “TYPE” .Press .



Step 2: input the diameter of the TOOL; Press   in turn..

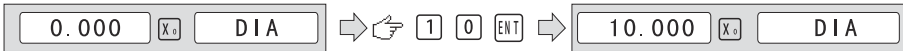

Step 3: Press  to the machining Mode.

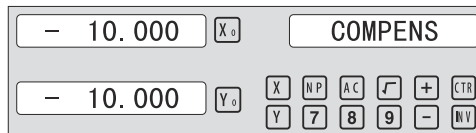

Machining of 2 side planes can be done by moving the TOOL until X-Axis is 150.000 and Y-Axis is 100.000.Press the Key  to quit the Function.

## 6.8 Digital Filter of the Grinding Machine

When machine a work-piece by grinder, the display values quickly due to the vibration of grinder. User can not see display value clearly. Grinder DRO provides display value filter function to disable the quake change of display value.

STEPS:

1. Enter display value filter function.

In normal display state, press **SIFT** to simultaneously, enter display value filter function.

2. Exit display value filter function;

Press **SIFT** , exit display value filter function;

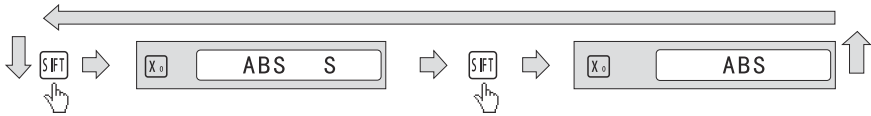

## 6.9 Lathe Function

### 6.9.1 200 sets TOOL Libs

It always needs different TOOL when processing different parts. For convenient operation, the Lathe digital readouts has the function of 200 sets TOOL Libs.

Note: Only when the lathe is equipped with the tool setting block , the 200 sets TOOL Libs can be used.

1. Set a datum TOOL. After tool setting, Zero X axis and Z axis, the set zero of absolute coordinate.
2. According to the size of TOOL1 and datumTOOL, determine the position ofTOOL relative to zero of absolute coordinate and datum tool. As Figure 6-1. The relative size of TOOL 2 is as follows X axis 25-30=-5, Z axis 20-10=10.
3. Save the TOOL number and the size into digital readout.
4. The number of TOOL can be input at random, the digital readouts will display the position of tool to absolute coordinate zero. Move lathe until X axis and Z axis both display zero.
5. TOOL Libs can save the 200 sets of the data of tools.
6. The TOOL Libs must be use in the opening state. The 200 sets TOOL Libs can be opened by continuously pressing  $\boxed{\pm}$  ten times until the right window flashes TL - OPEN and a mark “ $\Delta$ ” display at the left of the right information window. The Mark indicate the operator can setup or revise the 200 sets TOOL Libs. Continuously pressing the key  $\boxed{\pm}$  ten times will cause the 200 sets TOOL Libs to be closed and the right window flashes TL - CLOSE and the Mark disappear . When the Mark “ $\Delta$ ” disappear the 200 sets TOOL Libs can not be revised.

The operations for TOOL data and calling TOOL is shown as follows.

Step 1: In ABS state, input the data of the 200 sets TOOL Libs. To opening the 200 sets TOOL Libs by continuously pressing the key  $\boxed{\pm}$  ten time. A Mark “ $\Delta$ ” will appear at the left window of the right info window.

## Lathe Function

Step 2: Press **TOOL** to access the inputting state. Input TOOL 1 data:

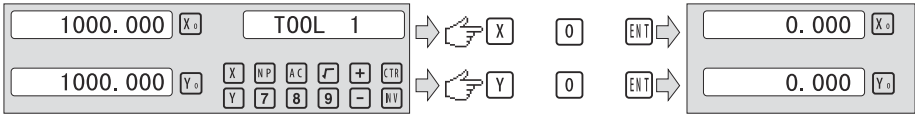

Step 3: Input TOOL 2 data:

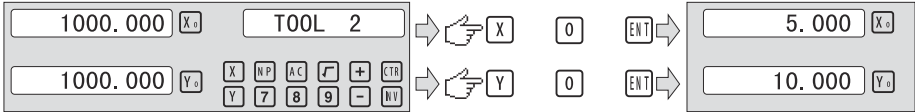

Step 4: Press to continue to input the data of next tool. By pressing number and the key **ENT**, the operator can directly input the special tool data. Press **TOOL** to quit.

After TOOL libs is setup. Use the TOOL libs according to the following operations first mount the second tool.

Step 5: To access the using state by press **CALL**. Then press **2 ENT**.



Step 6: Press **▲** or **▼**. Select the base TOOL. Then press **1 ENT**.



Step 7: Press **CALL** to quit the function;

Note:

- When the base tool is used, the axis can not be zeroed in ABS state.
- When the others are used, the axis can only be zeroed in INC state.

### 6.9.2 Taper Function

For lathing the workpiece with taper, the taper of the workpiece can be measured in processing;

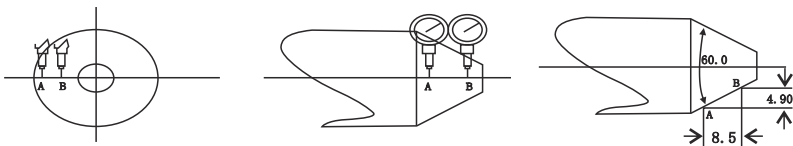

Operations :

As figure, contact surface A of workpiece with lever readouts and resets the lever readouts point to zero.

Step 1: Press , then the message window display “MEASU” to the paper processing. Move the lever readout to the surface B until the lever readouts point as follow;

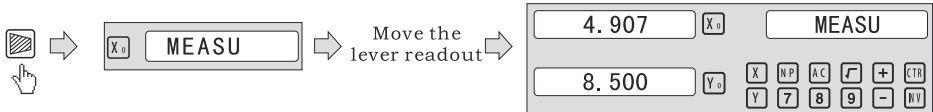

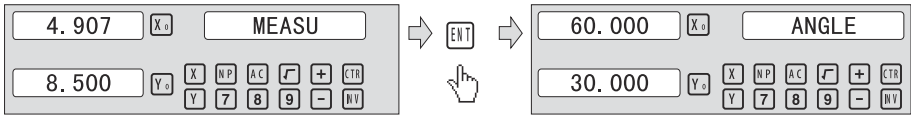

Step 2: Press  to calculate .



Step 3: press  to quit the function;

### 6.9.3 R/D Function

For 2 axes Lathe and 3 axes Lathe, press , The display Mode of X axis is switched between Radius and Diameter . When X axis for display of Diameter, A mark “” will appear at the left of the right information window, but when X axis for display of iameter , the mark “” disappear . Only X axis has the function of the diameter / radius transformation.

### 6.9.4 Y + Z Function ( only applicable to : 3 axes Lathe)

For 3 axes Lathe, the counter of Y axis and the counter of Z axis can be added to displayed in the Z axis by pressing the key , then press the key can cancel the Y + Z function.

6.10 EDM (Special customization function, if you need to buy, please contact the dealer to customize)

1、 Description: This function is used for the special machining of Electro Discharge Machining (EDM). When the set target value of EDM Z- axis is equal to the present value, the digital readout will output the switch signal to control EDM to stop the depth machining.

The setting of Z-axis direction the Digital Readout is shown as Fig 1, i.e. The deeper the depth is, the large the coordinate value of Z-axis displays. Since starting machining, the depth will gradually deepen and Z-axis.

According to the set Z-axis direction, the machining direction is divided into positive and negative machining. When the electrode descends and the machining is carried out from up to down, the digital readout value will increase, which is called positive machining (Positive). The setting of this direction is the normal setting.

When the electrode ascends and the machining is carried out from down to up, the digital readout value will decrease. The machining direction is negative direction (negative), which is also called negative machining (shown as Fig.1)

The Digital Readout also features other functions, such as negative fire proof-height. Negative fireproof height function is a kind of intelligent position follow check safety protective device. In the process of machining, the electrode surface will generate the carbon accumulation phenomenon. Due to the long-time or diurnal machining without tending , when generating the carbon accumulation and nobody makes the cleaning, the electrode will slowly increase along the negative direction. Once the electrode exceeds the liquid level, it will frequently catch fire and cause losses. This function is just set to aim at this problem. When setting negative fireproof height, and the increased height of electrode exceeds the height between it and the depth of machined surface (i.e. Negative fireproof height), the digital readout display will blink for warning; at the same time, the output signal will automatically turn off EDM to eliminate the fire chance.

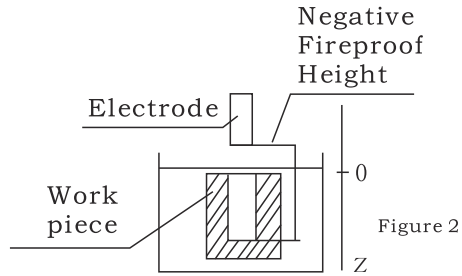
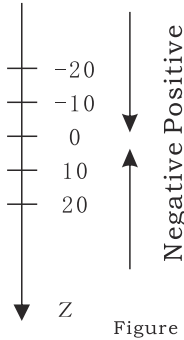

## 2. procedure :

See the following example for detailed machining.

- 1) Before machining, firstly set each parameter of DEPTH (machining depth);ERRHIGH( negative fireproof height), machining direction(POSITIVE / NEGATIVE) ; exit mode (AUTO/STOP) and EDM Relay Output Mode.
- 2) Move the main axis electrode of Z-axis to make it contact the workpiece reference. Clear A-axis to zero or set the value.
- 3) Enter EDM machining by press the key EDM.
- 4) X-axis will display Machining depth target value. Y-axis will display Value has been to be depth. ( The value on Y-axis is the value that the workpiece has been machined depth) Z-axis will display Self-position real time value. ( The value on Z-axis is the position value of the main axis electrode of Z-axis.)
- 5) Start machining, Z-axis display value is gradually close to the target value, and Y-axis display value is also gradually close to the target value. If at this time, the electrode is repeatedly up and down, Z-axis display value will change subsequently, but Y-axis display value will not change, which will always display the machined depth value.
- 6) When Z-axis display value is equal to the set target value, the position reaching switch will be turned off, EDM will stop machining, According to the operator setting. There are two kinds of exit modes:

## a) Automatic Mode:

it will automatically exit from EDM machining status and recover to the original state before machining;

## b) Stop Mode:

It will always stay at the machining interface after finishing machining, and you should press **EDM** to exit and back to the original state.

**Operation steps:**

**The DEPTH (machining Depth), ERRHIGH (Negative fireproof height), exit Mode, EDM Relay Output Mode and machining direction should be set.**

**STEPS:**

1. Press **EDM** to enter the EDM Function. Press **▲** to input parameters; Press **▼** to enter EDM machining state.

2. Input DEPTH ( machining depth). Press the key **▲** to set the next parameter.

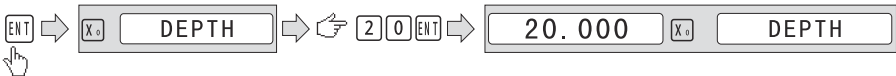

3. input ERRHIGH ( Negative Fireproof Height ) (undefine) .Press the key **▲** to set the next parameter.



4. Set machining direction(Positive or Negative). Press **1** to select Positive direction. Press **0** to select Negative direction. Press the key **▲** to set the next parameter.



5. Set exit Mode (AUTO Mode or STOP Mode) Press **0** to select AUTO Mode; Press **1** to select STOP Mode ; Press the key **▲** to set the next parameter.



6. Set the Output Mode (Mode 0 or Mode 1); ( undefine ). Press **0** to select Mode 0; Press **1** to select Mode 1.



7. Continuously press **▼** to return EDM for machining. press **EDM** to quit the function;

### Example 1: positive direction machining ;

Machining is shown as the model chamber as follows

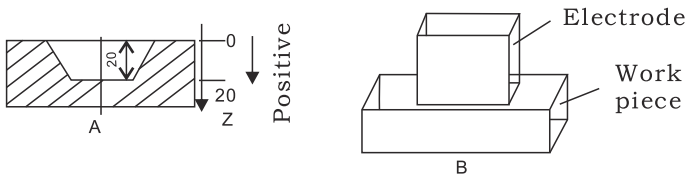

#### STEPS:

1、Touch one side of the workpiece with the TOOL, then press **Z<sub>0</sub>** , zero the Z axis.



2、 Press **EDM** , Setting DEPTH for 20.000; press **▼** to EDM for machining;

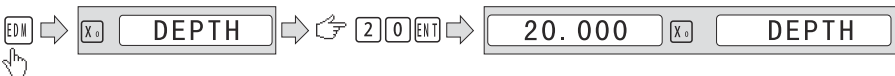

3、 Starting machining.

Machining depth target value	<input type="text" value="20.000"/>	<input type="button" value="X&lt;sub&gt;0&lt;/sub&gt;"/>	<input type="button" value="EDM RUN"/>
Value has been to be depth	<input type="text" value="0.000"/>	<input type="button" value="Y&lt;sub&gt;0&lt;/sub&gt;"/>	
Self-position real time value	<input type="text" value="0.000"/>	<input type="button" value="Z&lt;sub&gt;0&lt;/sub&gt;"/>	

**Example 2: Negative direction machining**

Machining is shown as the model chamber as follows

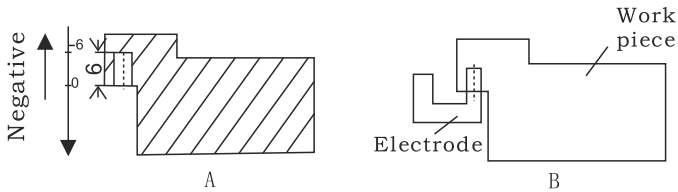

1、Touch one side of the workpiece with the TOOL, then press  , zero the Z axis.

→  →

2、Press  , Setting DEPTH for -20.000; press  to EDM for machining;

→   →    →

3、Starting machining.

Machining depth target value	<input type="text" value="20.000"/>	<input type="button" value="X&lt;sub&gt;0&lt;/sub&gt;"/>	<input type="button" value="EDM RUN"/>
Value has been to be depth	<input type="text" value="0.000"/>	<input type="button" value="Y&lt;sub&gt;0&lt;/sub&gt;"/>	
Self-position real time value	<input type="text" value="0.000"/>	<input type="button" value="Z&lt;sub&gt;0&lt;/sub&gt;"/>	

**Example 3: PCD Function for EDM**

PCD Function can access the EDM Function . The operator enters PCD Function to input parameters for PCD and enter PCD machining state. At every position for machining, press the key  to access the EDM Function .





When entering EDM Function, the operator can input the parameters for EDM.



The operation procedure is as follows:

1) Set PCD parameters(the setting is the same as the common setting of PCD)

After input all parameters and enter PCD machining state. The position of the first hole will be display.

2) Press  to enter EDM Function parameter( the setting methos is the same as the common setting of EDM parameter); after input all parameters , continuously press  to enter EDM machining state.

When the machining is done, press  to quit EDM function and enter PCD machining state.

3) In PCD machining state, press  for the position of the next hole, move the machine to the display value 0 , then press  to access EDM function again.

4) Repeat the step 2 and step 3 for the following machining points.

## 7 Calculator

The Calculator not only provides normal mathematical calculations such as +, -, x, /, it also provide trigonometric calculations such as SIN, Arc SIN, COS, Arc COS, TAN, Arc TAN SQRT etc.

The Operations are same as the commerical calculators, easy to use.

### **Enter and exit Calculator Function**

In normal display state: Press  $\boxed{\text{CTR}}$  to enter calculator function.

In calculator display state: Press  $\boxed{\text{CTR}}$  to exit calculator function.

### **Transferring the Calculator Results fo Selected Zxis.**

After calculating is finished, if the Calculator display Mode Set for mode 1, user can:

Press  $\boxed{X_0}$  to transfer the calculated result to X axis; then the X window will display this value;

Press  $\boxed{Y_0}$  to transfer the calculated result to Y axis; then the Y window will display this value;

Press  $\boxed{Z_0}$  to transfer the calculated result to Z axis; then the Z window will display this value;

### **Transferring the Current Display Value in window to Calculator.**

if the Calculator display Mode Set for mode 1, user can:

Press  $\boxed{X}$  to transfer the display value in X window to calculator;

Press  $\boxed{Y}$  to transfer the display value in Y window to calculator;

Press  $\boxed{Z}$  to transfer the display value in Z window to calculator;

8 Appendix

1. Troubleshooting:

The following are the preliminary solvents for troubleshooting.

If there is still trouble, Please contact out company or agents for help.

Troubles	Possible reasons	Solvents
No display	<ol style="list-style-type: none"> <li>1. Power isn't connected</li> <li>2. Power switch is off.</li> <li>3. The range of power voltage is not right.</li> <li>4. The inner power of Linear Scale is short.</li> </ol>	<ol style="list-style-type: none"> <li>1. Check power wire and connect the power</li> <li>2. Turn on the power switch.</li> <li>3. The range of voltage is in 80--260V</li> <li>4. Unplug the connector of linear scale</li> </ol>
One axis is not counting	<ol style="list-style-type: none"> <li>1. Replace the linear scale of the other axis.</li> <li>2. DRO is in special function</li> </ol>	<ol style="list-style-type: none"> <li>1. If count is normal, the linear scale has trouble; If abnormal, the DRO readouts has trouble.</li> <li>2. Quit the special function.</li> </ol>
Linear scale is not counting	<ol style="list-style-type: none"> <li>1. Reading head is bad for using range exceeds.</li> <li>2. Aluminum chips is in reading head of linear scale.</li> <li>3. The span between the reading head and metal part of linear scale is large.</li> <li>4. The metal parts of linear scale is damage.</li> </ol>	<ol style="list-style-type: none"> <li>1. Repair the linear scale</li> <li>2. Repair the linear scale</li> <li>3. Repair the linear scale</li> <li>4. Repair the linear scale</li> </ol>
Counting is error	<ol style="list-style-type: none"> <li>1. Shell is poor grounding.</li> <li>2. Low precision of machine.</li> <li>3. Speed of machine is too rapid.</li> <li>4. Precision of linear scale is low.</li> <li>5. The resolution of DRO readouts and the linear scale is not match.</li> <li>6. The unit (mm/inch) is not match.</li> <li>7. Setting the linear compensating is not arrest.</li> <li>8. Reading head of the linear scale is damaged.</li> </ol>	<ol style="list-style-type: none"> <li>1. Shell is good grounding.</li> <li>2. Repair the machine.</li> <li>3. Reduce the speed of machine.</li> <li>4. Mount the linear scale again.</li> <li>5. Set the resolution of the DRO again,</li> <li>6. Cover the unit of display mm/inch.</li> <li>7. Reset the linear compensation.</li> <li>8. Repair the linear scale.</li> </ol>
The counting of the linear scale is not accurate	<ol style="list-style-type: none"> <li>1. The mounting of linear scale does not demand the requirement, and the prcision is not adequate.</li> <li>2. The screw is loosen.</li> <li>3. Precision of machine is low.</li> <li>4. The resolution of digital readouts and the linear scale is not match.</li> </ol>	<ol style="list-style-type: none"> <li>1. Mount the linear scale again and level it.</li> <li>2. Lock all fixing screws.</li> <li>3. Repair the machine.</li> <li>4. Reset the resolution of digital readouts.</li> </ol>
Sometimes the linear scale is not counting	<ol style="list-style-type: none"> <li>1. The small car and steel ball is separated.</li> <li>2. The glass of reading head is wearied.</li> <li>3. The glass of reading head of the linear scale has dirt.</li> <li>4. The elasticity of the steel wire is not adequate.</li> </ol>	<ol style="list-style-type: none"> <li>1. Repair the linear scale.</li> <li>2. Repair the linear scale.</li> <li>3. Repair the linear scale.</li> <li>4. Repair the linear scale.</li> </ol>

## 2. Specifications of Digital Readout.

- 1) Supply Voltage range: AC 85 V ~ 230 V; 50 ~ 60 Hz
- 2) Power consumption: 15VA
- 3) Operating temperature: 0°C-- 50°C
- 4) Storage temperature: - 30°C-- 70°C
- 5) Relative humidity: < 90 % ( 25 )
- 6) Max Coordinate number: 3
- 7) Readout allowable input signal: TTL square wave
- 8) Allowable input signal frequency: < 5 M Hz
- 9) Max resolution of digital display length: 0.01 um
- 10) Max resolution of digital display angle: 0.0001 / PULSE

## 3. Instructions

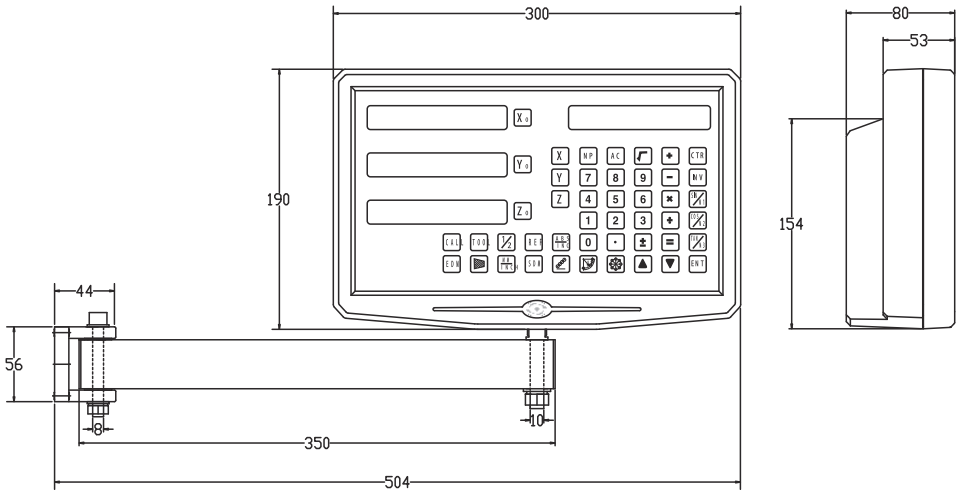

#### 4. Examples of character output at the data interface

##### 1、 X,Y,Z Axis

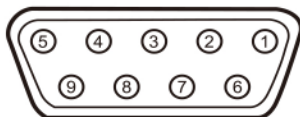

Pin	TTL (Standard)
1	
2	OV
3	
4	
5	
6	A+
7	5V
8	B+
9	R+

Pin	TTL (Standard)
1	5V
2	OV
3	A+
4	B+
5	R+
6	
7	
8	
9	

For your convenience,  
If you buy a digital readout,

The wiring definition of your linear scale must be the same as the 2 definitions in the above diagram to be universal!

# Installation Instructions

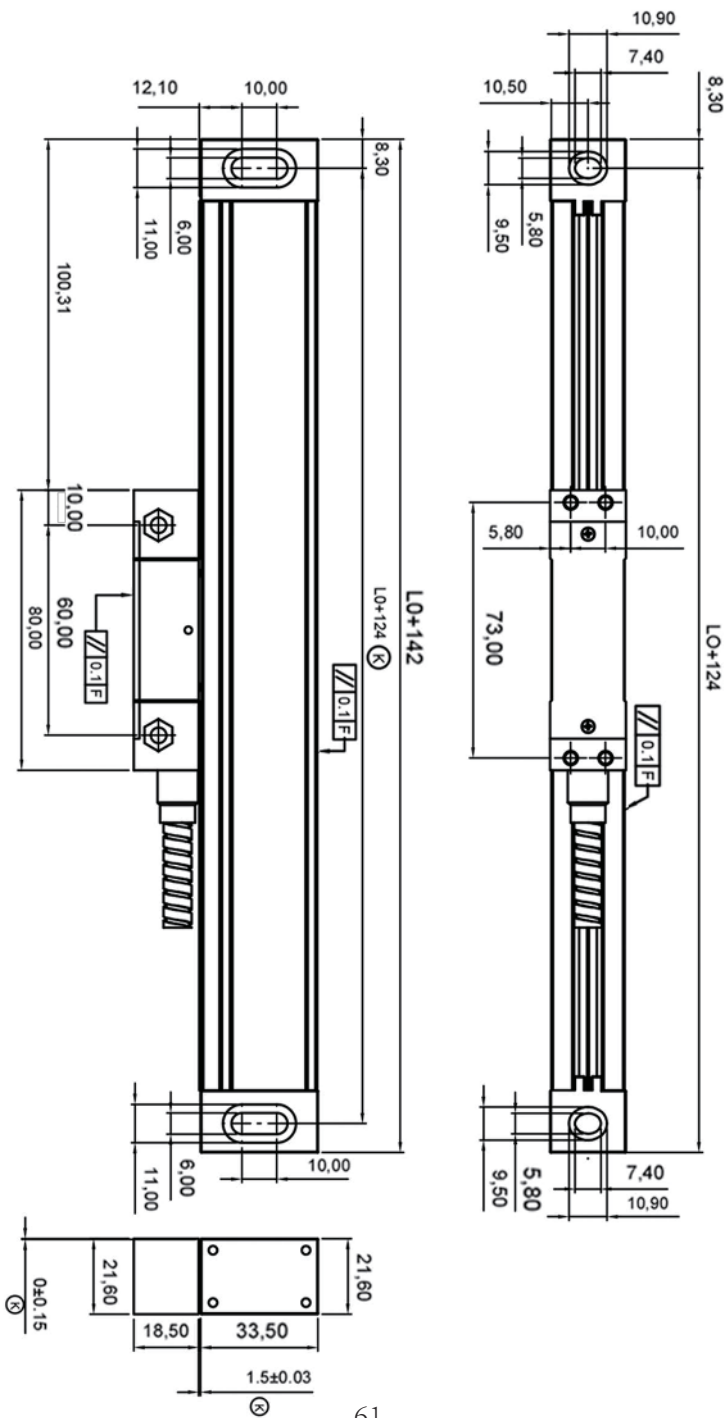

## TTL signal Output:

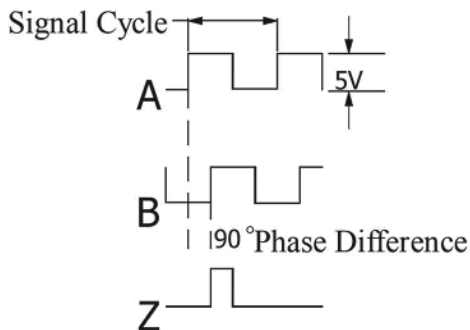

## EIA-422-A signal Output:

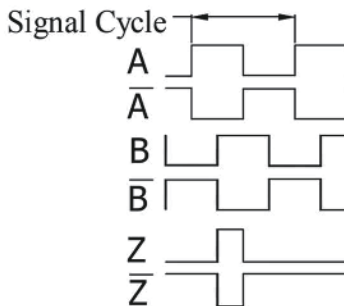

### 1. TECHNICAL PARAMETER

1.1 SCALING DISTANCE: 0.02 MM (50LINES /MM)

1.2 RESOLUTION: 5 $\mu$ M、1 $\mu$ M、0.5 $\mu$ M

1.3 PRECISION:  $\pm 3\mu$ M、 $\pm 5\mu$ M、 $\pm 15\mu$ M/M (20 $\pm$ 0.1 $^{\circ}$ C)

1.4 MEASURING RANGE: 30~3000MM

1.5 MOVING SPEED: HIGH-SPEED ENCODER 120 M/MIN (TO BE CUSTOMIZED)

ORDINARY ENCODER 60M/MIN

1.6 POWER SUPPLY: +5V $\pm$ 5%、80MA

1.7 CABLE LENGTH: STANDARD 3M (SPECIAL LENGTH AVAILABLE ACCORDING TO THE USER'S NEEDS)☒

1.8 WORKING TEMPERATURE: 0~45 $^{\circ}$ C

1.9 PIN DESCRIPTION:

1) APPLICABLE TO: 9 PIN SOCKET EIA-422-A SIGNAL OUTPUT.

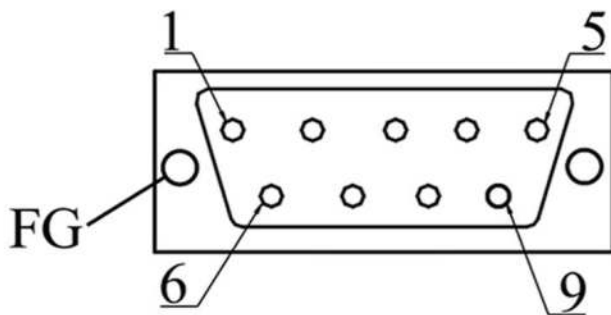

1) Applicable to: 9 pin socket EIA-422-A signal Output.

Pin Position	1	2	3	4	5	6	7	8	9
Signal	$\bar{A}$	$OV$	$\bar{B}$	Empty	$\bar{Z}$	$A$	+5V	$B$	$Z$
Color	Green Black	Black	Orange black	FG	White black	Green	Red	White	Orange

FG: Shield connected to metal casing.

1) Applicable to: 9 pin socket TTL signal Output.

Pin Position	1	2	3	4	5	6	7	8	9
Signal		$OV$		Empty		$A$	+5V	$B$	$Z$
Color		Black		FG		Green	Red	Orange	White

FG: Shield connected to metal casing.

# **Linear scale**

## Installation drawings

# Installation method:

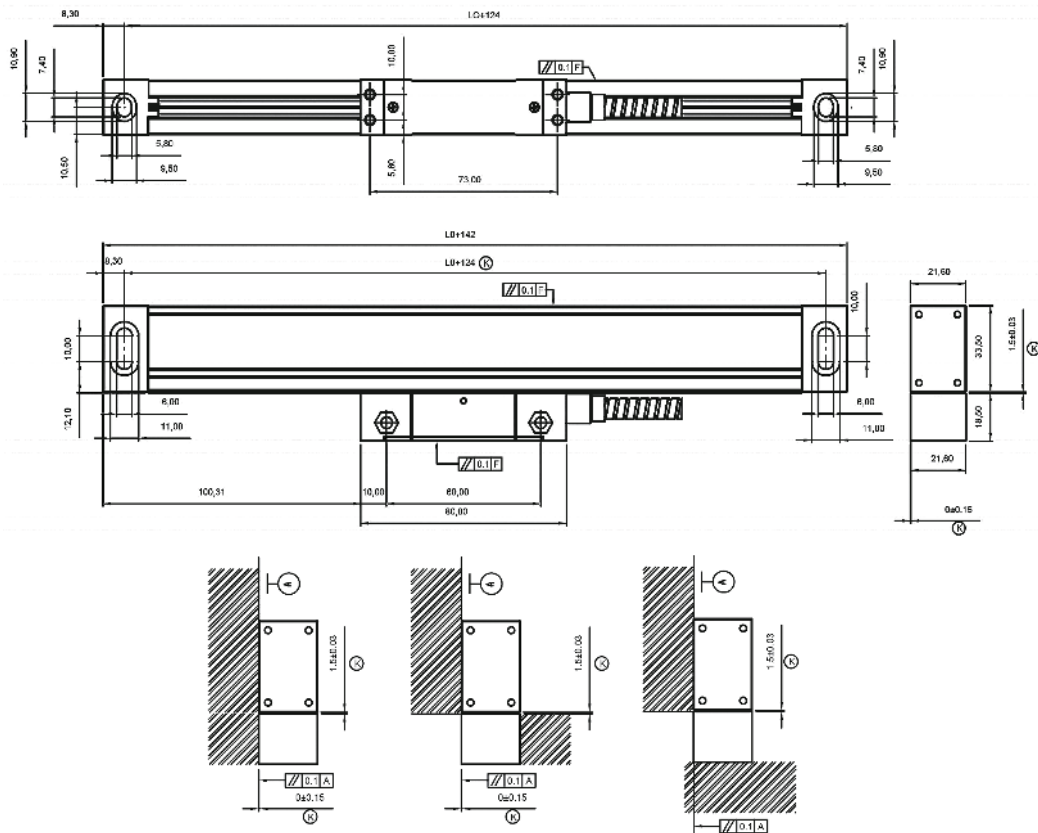

## Standard size: (Unit:mm)

Model	L0	L1	L2	Model	L0	L1	L2
YE-50	50	174	190	YE-550	550	674	690
YE-100	100	224	240	YE-600	600	724	740
YE-150	150	274	290	YE-650	650	774	790
YE-200	200	324	340	YE-700	700	824	840
YE-250	250	374	390	YE-750	750	874	890
YE-300	300	424	440	YE-800	800	924	940
YE-350	350	474	490	YE-850	850	974	990
YE-400	400	524	540	YE-900	900	1024	1040
YE-450	450	574	590	YE-950	950	1074	1090
YE-500	500	624	640	YE-1000	1000	1124	1140

L0: Effective measuring length of the linear encoder; L1: Length of linear encoder mounting holes; L2: Linear encoder overall length

# Maintenance:

1. The effective travel of the linear encoder should be longer than the maximum travel of the machine tool. If the length is not enough, replace the linear encoder with a larger stroke or add a limit block on the machines. The end position of the reading head from the end of the linear encoder body should be not less than 10mm space, (see the following diagram).

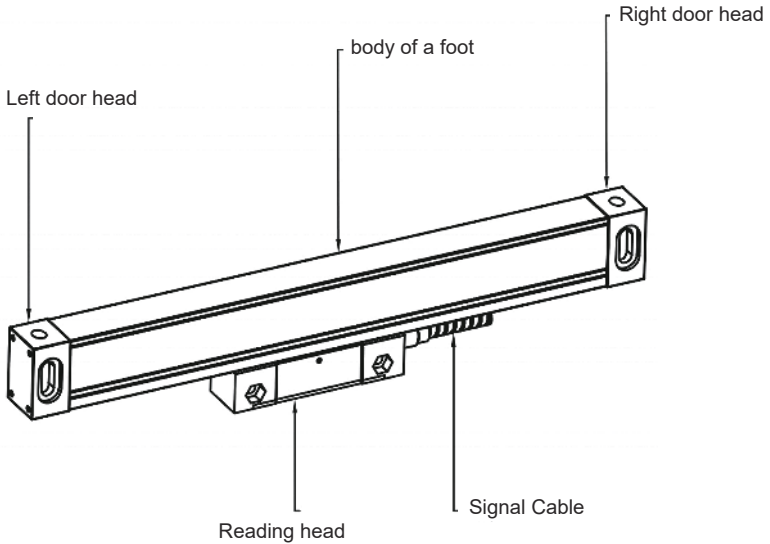

2. For any non-machined surface, a shim must be placed on the back of the linear encoder or a user-made installation shim must be used to ensure the stability and reliability of the connection between the grating ruler and the mounting surface.
3. When using a dial gauge or similar instrument to calibrate the parallelism of the linear encoder, the angle of the side head must be within  $\pm 30$  degrees, and the smaller the angle, the better.

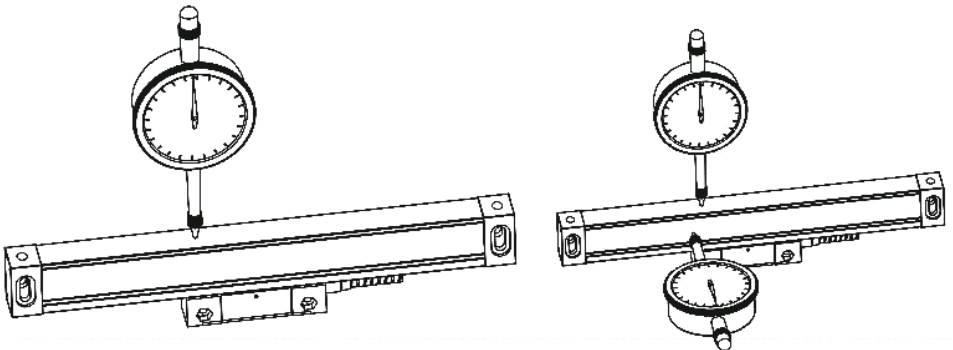

4. The installation position of the linear encoder must avoid direct impact from iron filings, oil, water, and dust (as shown in the figure below). The installation length of the L-plate should be as short as possible under possible circumstances, and the force situation of the mounting surface must be taken into consideration.

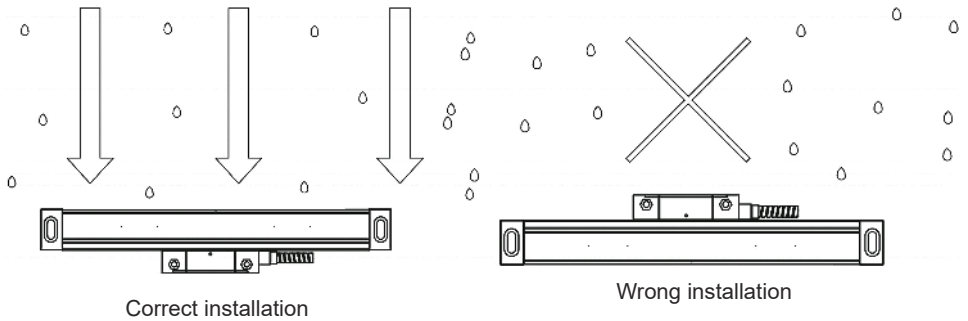

5. There must be a gap of 0.5mm or more between the dust cover and the ruler body, and avoid contact between the dust cover and the ruler body when moving the reading head (as below).
6. Installation screw thread depth, at least must have 6 teeth of locking depth; force greater part, such as supporting the digital display meter shelf fixed plate, must have 8 teeth of locking depth; YE series of scale, the depth of the thread depth of the locking depth. Such as supporting the digital display meter shelf fixed plate, must have more than 8 teeth locking depth; YE series scale With M4 screws installed mounting surface tapping after surface deburring, paint, stain removal. (The following figure)

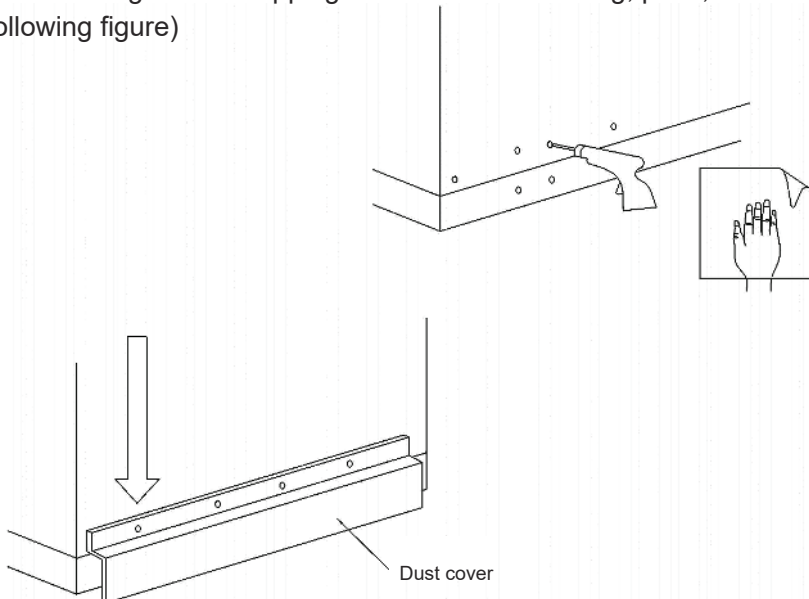

7. The fixing of the signal line must take into account all relevant moving distances. Fixing position as far as possible placed in the very center of the stroke, and the excess signal line is fixed with a wire tie.
8. Adjustment of the scale height level must be the length of the scale center to take the two sides of the symmetry point. Do adjust the reference point, any scale regardless of the school level direction or height direction, the Adjustment range: for the scale body, to the head from the scale body at a distance of not more than 20mm from each end shall prevail. For the reading head, between the two quadrilateral reference surfaces (the following figure)

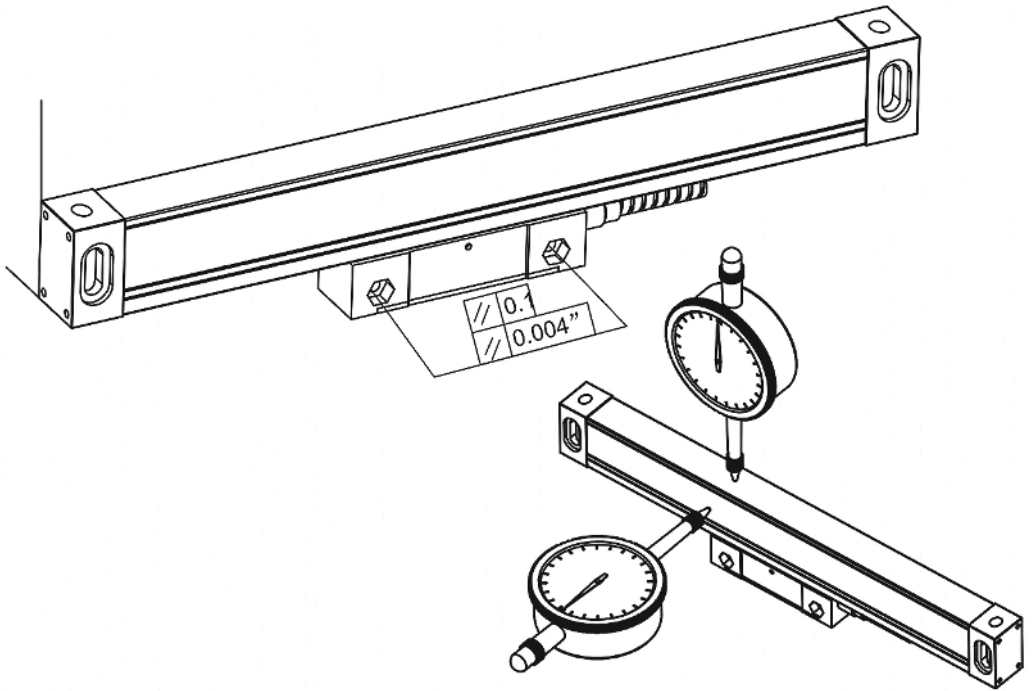

9. The bending radius of the signal line of the scale is greater than 60mm.

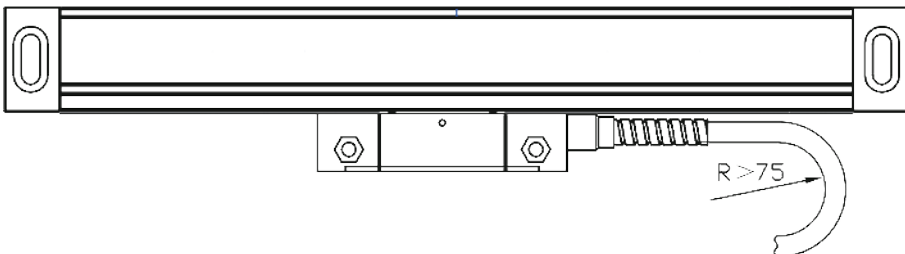

## 10. Scale installation standard

- (1) Installation base surface standard (Figure 4.8a.b.c three installation methods)
  1. The installation surface of the ruler body is parallel to the installation surface of the reading head, and the parallelism between the installation surfaces is  $<0.1\text{mm}$
  2. The installation surface of the ruler body is perpendicular to the installation surface of the reading head, and the perpendicularity between the installation surfaces is  $<0.1\text{mm}$
- 2) Ruler body installation standards (Figure 4.9, Figure 4.10)
  1. Height direction relative to the machine guide parallelism  $<0.1\text{mm}$ , maximum not more than  $0.15\text{mm}$  In terms of symmetry point, the smaller the better.
- 3) Standard of reading head installation
  1. The clearance between the reading head and the height direction of the ruler body is  $0.8\text{mm}-1.6\text{mm}$  after installation, and then withdraw the pad block (Figure 4.11)

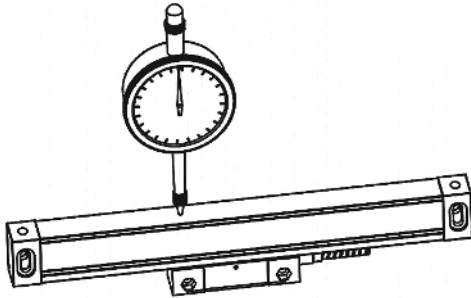

4.9

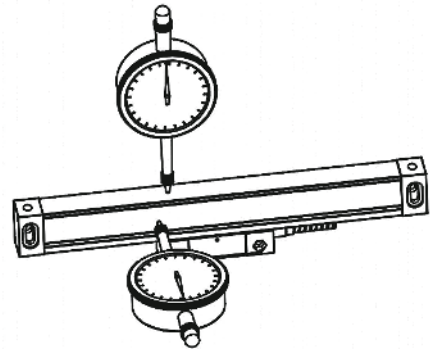

4.10

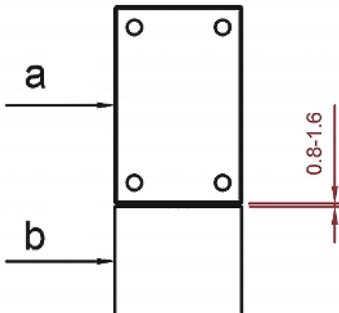

2. Reading head a side and ruler body B side. Misalignment in horizontal direction.  $0.25\pm 0.15\text{mm}$
3. Parallelism of reading head relative to machine tool  $<0.10\text{mm}$ , maximum cannot exceed  $0.30\text{mm}$

## Parameter:

Model	SNS-3V-YE102024	SNS-3V-YE161838
Rated voltage:	AC85-230V 50Hz/60Hz	
Resolution	5 $\mu$ m	
Number of axes	3	
Range	10 inches 20 inches 24 inches	16 inches 18 inches 38 inches

## Standard accessories:

Accessories for digital display meters:	Accessories for grating ruler:
<ol style="list-style-type: none"><li>Support rod * 1</li><li>Knife holder plate * 1</li><li>Transparent watch case * 1</li><li>Power cord * 1</li><li>Watch holder * 1</li><li>Butterfly piece * 2</li><li>M8 * 70 screw * 1</li><li>M10 * 55 screw * 1</li><li>Nut M10 * 1</li><li>Nut M8 * 1</li><li>Nut M5 * 1</li><li>Internal hexagonal screw M5 * 20 * 2</li><li>Internal hexagonal screw M5 * 25 * 1</li><li>M4 * hex socket screw * 4</li><li>M5 * 10 machine meter screws * 2</li><li>Washer <math>\phi</math> 10 * 1</li><li>Washer <math>\phi</math> 8 * 1</li><li>Washer <math>\phi</math> 5 * 1</li><li>Rubber washer 20 * 10 * 1 * 1</li><li>Rubber washer 20 * 10 * 0.5 * 1</li><li>Spring washer <math>\phi</math> 10 * 1</li><li>Spring washer <math>\phi</math> 8 * 1</li><li>Spring washer <math>\phi</math> 5 * 1</li></ol>	<ol style="list-style-type: none"><li>Ruler cover * 3</li><li>L mounting plate * 4</li><li>Plug * 6</li><li>Screw pack * 3 bags</li></ol> <p>Each bag contains:</p> <ul style="list-style-type: none"><li>Internal hexagonal screw M4 * 30 * 4;</li><li>Internal hexagonal screw M4 * 12 * 2;</li><li>Internal hexagonal screw M4 * 8 * 4;</li><li>U-shaped gasket T=0.2mm * 2;</li><li>Washer <math>\phi</math> 6 * 2;</li><li>Washer <math>\phi</math> 5 * 2;</li><li>Washer <math>\phi</math> 4 * 6;</li><li>Line card * 2</li></ul>

This device complies with Part 15 of the FCC Rules. Operation is subject to the following two conditions:(1)This device may not cause harmful interference, and (2)this device must accept any interference received, including interference that may cause undesired operation.

**Manufacturer:** Shanghaimuxinmuyeyouxiangongsi

**Address:** Shuangchenglu 803nong11hao1602A-1609shi, baoshanqu, shanghai 200000 CN.

**Imported to AUS:** SIHAO PTY LTD, 1 ROKEVA STREETEASTWOOD NSW 2122 Australia

**Imported to USA:** Sanven Technology Ltd., Suite 250, 9166 Anaheim Place, Rancho Cucamonga, CA 91730

<b>EC</b>	<b>REP</b>
-----------	------------

E-CrossStu GmbH  
Mainzer Landstr.69, 60329 Frankfurt am Main.

<b>UK</b>	<b>REP</b>
-----------	------------

YH CONSULTING LIMITED.  
C/O YH Consulting Limited Office 147, Centurion House,  
London Road, Staines-upon-Thames, Surrey, TW18 4AX

# VEVOR®

**TOUGH TOOLS, HALF PRICE**

**Technical Support and E-Warranty Certificate**

[www.vevor.com/support](http://www.vevor.com/support)

# VEVOR®

## TOUGH TOOLS, HALF PRICE

Assistance technique et certificat de garantie électronique

[www.vevor.com/support](http://www.vevor.com/support)

### MANUEL D'UTILISATION DE L'AFFICHAGE DRO

MODÈLE : SNS-3V-YE102024 IS NS-3V-YE161838

nous continuons à nous engager à vous fournir des outils à des prix compétitifs.  
« Sauver la moitié », « Moitié prix » ou toute autre expression similaire utilisée par nous ne représente qu'une estimation des économies que vous pourriez réaliser en achetant certains outils chez nous par rapport aux principaux grandes marques et ne vise pas nécessairement à couvrir toutes les catégories d'outils que nous proposons. Vous nous vous rappelons de bien vouloir vérifier attentivement lorsque vous passez une commande chez nous si vous êtes en fait, vous économisez la moitié par rapport aux grandes marques.

**VEVOR**<sup>®</sup>  
TOUGH TOOLS, HALF PRICE

AFFICHAGE DRO

MODÈLE : SNS-3V-YE102024 SNS-3V-YE161838



### BESOIN D'AIDE? CONTACTEZ-NOUS!

Vous avez des questions sur les produits ? Besoin d'assistance technique ? N'hésitez pas à nous contacter.  
Contactez-nous:

Assistance technique et certificat de garantie électronique  
[www.vevor.com/support](http://www.vevor.com/support)

Ceci est l'instruction originale, veuillez lire toutes les instructions du manuel attentivement avant de l'utiliser. VEVOR se réserve une interprétation claire de notre manuel d'utilisation. L'apparence du produit sera soumise à la produit que vous avez reçu. Veuillez nous pardonner, nous ne vous informerons plus s'il y a des mises à jour technologiques ou logicielles sur notre produit.

Chers utilisateurs :

Nous vous remercions d'avoir acheté les afficheurs numériques multifonctions de la série .  
Les affichages numériques sont utilisés dans une grande variété d'applications. Celles-ci incluent machines-outils , dans les axes d'alimentation, les équipements de mesure et d'inspection, l'EDM et les appareils de division, outils de réglage , stations de mesure pour contrôle de la production. Afin de répondre aux exigences de ces applications, de nombreux encodeurs peuvent être connectés aux lectures numériques. Lisez attentivement toutes les instructions du manuel avant utilisation et suivez-les strictement · conservez le manuel pour référence ultérieure ·

Attention à la sécurité :

- ⌘ Pour éviter les chocs électriques ou les incendies, l'humidité ou les projections directes Il faut éviter d'utiliser du liquide de refroidissement. En cas de fumée ou de phénomènes particuliers une odeur se dégage de l'affichage numérique, veuillez débrancher la prise d'alimentation immédiatement, sinon, un incendie ou un choc électrique pourrait se produire. un tel cas, n'essayez pas de le réparer, veuillez contacter l'entreprise ou **distributeurs.**
- ⌘ L'affichage numérique est un appareil de mesure précis utilisé avec un appareil optique Échelle linéaire · lorsqu'elle est utilisée, si la connexion entre le L'échelle linéaire et l'affichage numérique sont cassés ou endommagés de l'extérieur, des valeurs de mesure erronées peuvent en résulter · Par conséquent, l'utilisateur doit être prudent.
- ⌘ N'essayez pas de réparer ou de modifier l'affichage numérique, sinon, vous risquez de tomber en panne. une panne ou une blessure peut survenir. En cas de condition anormale, Veuillez contacter l'entreprise ou le distributeur.
- ⌘ Si l'échelle linéaire optique utilisée avec l'affichage numérique est endommagée, n'utilisez pas d'échelle linéaire d'une autre marque. · En raison des performances, des spécifications et de la connexion des produits de différentes marques, ne doit pas être connecté sans l'instruction d'un technicien spécialisé personnel, sinon des problèmes seront causés à l'affichage numérique.
- ⌘ **With the continuous updating of products, if there are changes or**  
En cas de modification des paramètres de l'échantillon, les fichiers aléatoires prévalent et la société a le droit d'interprétation finale sans préavis.

## Contents

---

1.	Illustration of Panel and keyboard .....	4
2.	Caption of the keyboard .....	5
3.	Parameters settings .....	7
3.1	Parameters setup routine entrance .....	7
3.2	Parameters Settings Description .....	7
3.2.1	Setting the Resolution .....	7
3.2.2	Setting Positive Direction for Counter .....	8
3.2.3	Toggle Between R/D Display Mode .....	8
3.2.4	Setting Z axis Dial .....	8
3.2.5	Setting the Rotary Radius of the Workpiece.....	9
3.2.6	Setting the Angle Display Mode .....	9
3.2.7	Setting the Baudrate of RS_232(optional) .....	9
3.2.8	Setting the Absolute Zeroing enable or disable .....	10
3.2.9	Setting the Absolute form the Special Function .....	10
3.2.10	Setting the Calculator display Mode.....	10
3.2.11	display brightness setting .....	10
3.2.12	The linear scale counting frequency setting .....	11
3.2.13	Setting QUIT .....	11
3.2.14	Setting the type of the DRO. ....	11
3.2.15	Signal Interface Type .....	11
3.2.16	Restore Factory Settings: .....	12
3.2.17	Shrinkage Ratio enable or disable.....	12
3.2.18	Setting Compensation Type .....	12
3.2.19	Inch display, set the number of digits after the decimal point...	13
3.2.20	Setting EDM(optional) .....	13
3.2.21	Setting Linearity Compensation. ....	13
3.2.22	Setting the Shrinkage Ratio .....	13
4.	General Operations .....	14
4.1	Zeroing.....	14
4.2	Preset Data to Designated Axis .....	14
4.3	Toggle Display Unit between inch and mm .....	14
4.4	Absolute/Incremental/200 groups SDM .....	15
4.5	1/2 Function .....	15
4.6	Clear All SDM Datum.....	16

## Contents

---

4.7 Sleeping Mode .....	16
4.8 Power Interruption Memory .....	16
4.9 Search the Absolute Reference Point of Scale .....	17
4.10 Non Linear Error Compensation .....	20
5、200 Groups SDM coordinate .....	21
5.1 Zeroing at the Current Point.....	21
5.2 Preset datum of SDM coordinate .....	22
6、Special Function.....	24
6.1 Circumference Holes Processing .....	25
6.2 Linear Holes Processing .....	28
6.3 ARC Processing .....	30
6.4 Oblique Processing .....	39
6.5 Slope Processng.....	43
6.6 Chamber Processing.....	44
6.7 The Tool Diameter Compensation Function .....	45
6.8 Digital Filter of the Grinding Machine .....	46
6.9 Lathe Function .....	47
6.9.1 200 sets TOOL Libs .....	47
6.9.2 Taper Function .....	48
6.9.3 R/D Function .....	49
6.9.4 Y + Z Function ( only applicable to : 3 axes Lathe).....	49
6.10 EDM.....	50
7、Calculator.....	56
8、Appendix .....	57

## Illustration of Panel and keyboard

## THREE AXIS PANEL

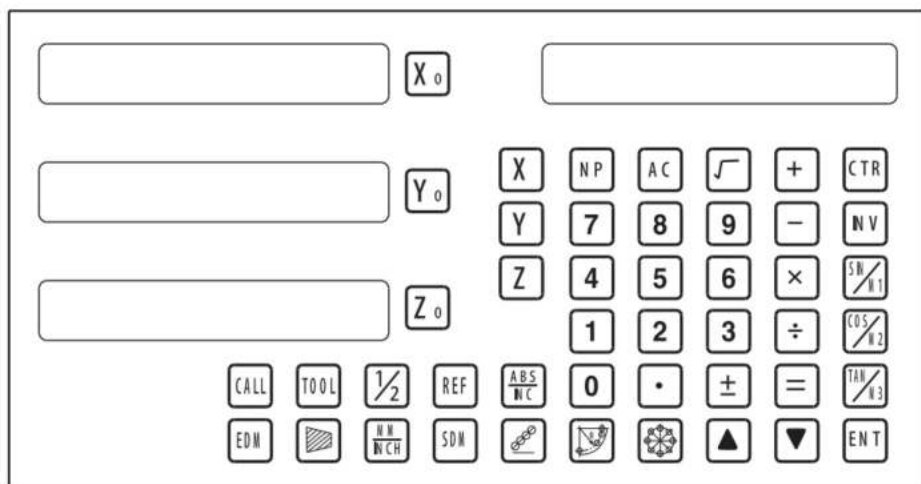



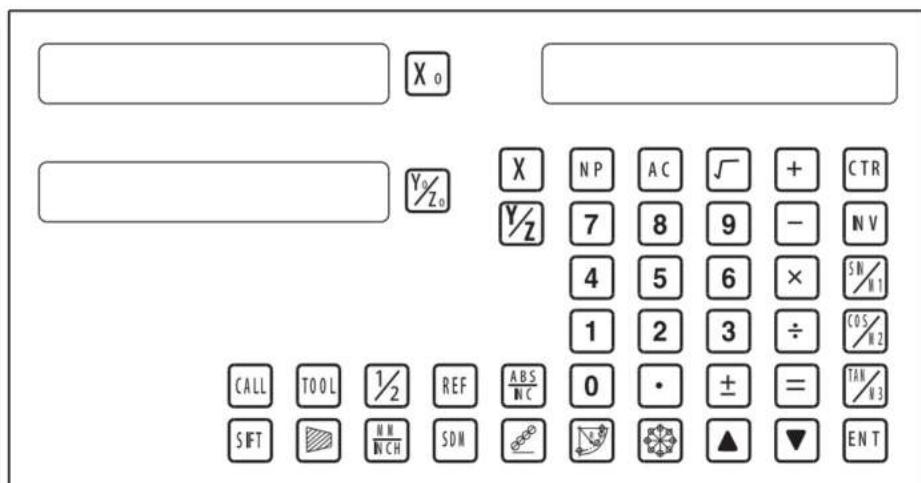































## TWO AXIS PANEL















## Caption of the keyboard

## Keyboard Description

  	Keys for axis selection
  	Zero select axis
	Enter +/- sign
	Enter decimal point
         	Entry keys for numbers
    	Operation key (in Calculation function key)
	Enter or quit calculating state
	Cancel incorrect operation
	Calculate inverse trigonometric
	Square root
	Confirm operation
	Toggles between inch and millimeter units.
	Press when ready to identify a reference mark.
	Function keys for 200 sub datum
	ARC cutting function
	holes displayed equally on a circle
	holes displayed equally on a line

## Caption of the keyboard

	Calculate trigonometric or Slope Processing function key
	Calculate trigonometric or rectangular inner chamber processing function key
	Calculate trigonometric or the tool diameter compensation function key
	Toggle between ABS/INC coordinate
	Stroll up or down to select
	Taper measured function key
	Tool library call key
	Opens the tool table.( lathe)
	EDM function key
	Filter display function key
	Half a display value of an axis
	Non Linear Error Compensation function keys

## Parameters settings

## 3. Parameters settings

## 3.1 Parameters setup routine entrance.

Press  $\square \bullet$  to enter initial system and self-check after DRO powers on in 1 second, then Parameters settings display in the Parameters window. Press  $\blacktriangle$   $\blacktriangledown$  to select the item you want to change.

If you want to quit initial setting, press  $\blacktriangle$   $\blacktriangledown$  until "QUIT" appears in message window and press  $\square \text{ENT}$ . You can also press  $\square \bullet$  to quit initial setting.

## 3.2 Parameters Settings Description

## 3.2.1 Setting the Resolution

Press  $\blacktriangle$   $\blacktriangledown$  until "RESOLUTE" appears in message window;

When selecting the LINEAR encode, the resolution will be set as follow:

There are 19 types of resolution:

0.01um;0.02um;0.05um;0.10um;0.20um;0.25um;0.50um;1.00um;2.00um;2.50um;5.00um;10.00um;20.00um;25.00um;50.00um;100.00um;200.00um;250.00um;500.00um.

Press  $\square X_0$  to change the resolution for X axis; Press  $\square Y_0$  to change the resolution for Y axis; Press  $\square Z_0$  to change the resolution for Z axis;

Set the resolution 5.00um to 1.00um for X axis:

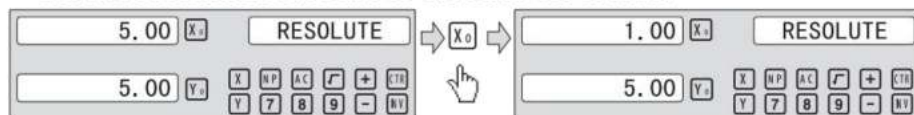

When selecting the rotary encode, the resolution will be set as follow:

Input the rotary encode parameter value .

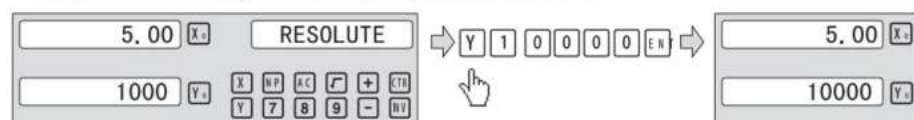

## Parameters settings

## 3.2.2 Setting Positive Direction for Counter

Press  $\blacktriangle$   $\blacktriangledown$  until “DIRECTE” appears in message window.

Direction ‘0’ means the display value will increase when scale moves from right to left and decrease when scale moves from left to right. Direction ‘1’ means the display value will increase when scale moves from left to right and decrease when scale moves from right to left.

Press  $X_0$  to change the Direction for X axis; Press  $Y_0$  to change the Direction for Y axis; Press  $Z_0$  to change the Direction for Z axis; as follow:

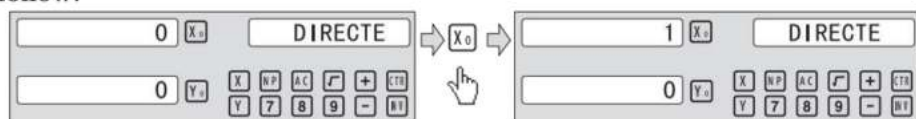

## 3.2.3 Toggle Between R/D Display Mode

Press  $\blacktriangle$   $\blacktriangledown$  until “R OR D” appears in message window. X window, Y window, Z window displays ‘0’ or ‘1’ separately.

‘0’ is mode R, which means the display value equals the actual measurement. ‘1’ is mode D where the display value equals the double actual measurement. Press  $X_0$  to change the R/D for X axis; Press  $Y_0$  to change the R/D for Y axis; Press  $Z_0$  to change the R/D for Z axis; as follow:

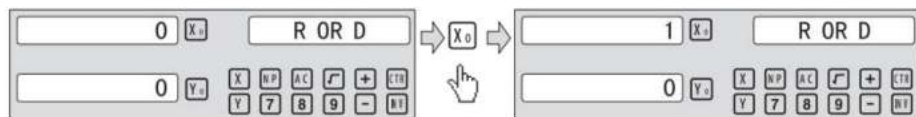

## 3.2.4 Setting Z axis Dial

Press  $\blacktriangle$   $\blacktriangledown$  until “Z DIAL” appears in message window.

Z axis dial should be set if Z axis is emulated for 2 axis milling and only install linear scale for X,Y axis. Z axis dial means the distance the Z axis travels when screw runs a revolution.

## Parameters settings

Set the Z axis Dial 2.5mm as follow ;



### 3.2.5 Setting the Rotary Radius of the Workpiece

Press  $\blacktriangle$   $\blacktriangledown$  until “RDIUS” appears in message window.

The Rotary radius type is used perimeter to measure angle.

Input the Rotary Radius parameter value 2000mm as follow:

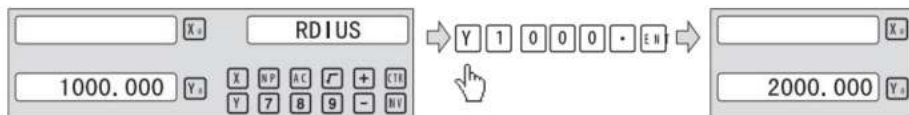

### 3.2.6 Setting the Angle Display Mode

Press  $\blacktriangle$   $\blacktriangledown$  until “ANG DISP” appears in message window.

Press  $X_0$  to change the angle display mode for X axis; Press  $Y_0$  to change the angle display mode for Y axis; Press  $Z_0$  to change the angle display mode for Z axis; Example for X axis:

“0.0000” means the angle mode is Circulating DD;

“0000.0000” means the angle mode is Incremental DD;

“0.00.00” means the angle mode is Circulating DMS;

“0000.00.00” means the angle mode is Incremental DMS;

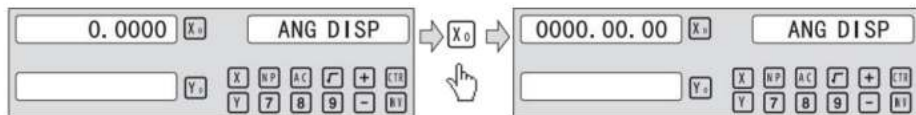



### 3.2.7 Setting the Baudrate of RS\_232 (Special customization function, if you need to buy, please contact the dealer to customize)

Press  $\blacktriangle$   $\blacktriangledown$  until “BAUDRATE” appears in message window.

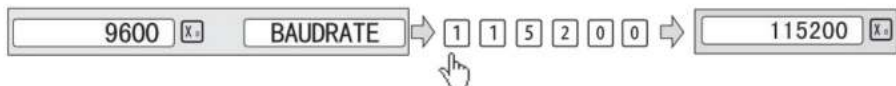

Set the Baudrate 115200 as follow ;



## 3.2.8 Réglage de l'activation ou de la désactivation de la mise à zéro absolue



pressez   jusqu'à ce que « ABS ZÉRO » apparaisse dans la fenêtre de message. le signifie que le fonctionnement de la mise à zéro ABS et des données prédéfinies sera activé dans l'état d'affichage normal.

'1' signifie que le fonctionnement de la mise à zéro ABS et des données prédéfinies sera désactivé dans l'état d'affichage normal.

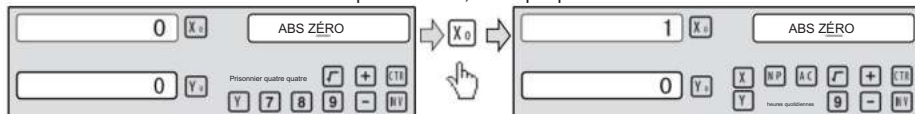
appuyez sur  pour modifier le mode de mise à zéro absolue de l'axe x, appuyez sur  pour modifier le mode de mise à zéro absolue pour l'axe Y, appuyez sur  à modifier le mode de mise à zéro absolue pour l'axe Z ; Exemple pour l'axe x :





## 3.2.9 définition de la forme absolue de la fonction spéciale

pressez   jusqu'à ce que « ABS ASST » apparaisse dans la fenêtre de message. '0' signifie que seule la valeur de position de fonction spéciale est affichée dans l'opération de fonction spéciale.

'1' signifie valeur de position de fonction spéciale + ABS La valeur de position est affichée dans l'opération de fonction spéciale.

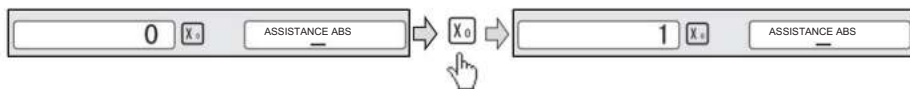
pressez  pour changer le mode absolu de la fonction spéciale, être défini comme suit :

3.2.10 réglage de la **Calculator** Mode d'affichage

pressez   jusqu'à ce que « UCCTR MODE » apparaisse dans le message Window. le message de la calculatrice affiche la valeur au vent x dans le moyen la calculatrice affiche la valeur dans la fenêtre de message dans l'affichage ;

pressez  pour changer le mode d'affichage de la calculatrice sera défini AS follow:

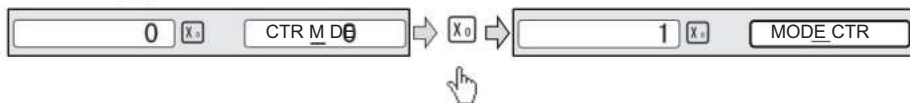

## 3.2.11 Réglage de la luminosité de l'écran

Réglage de la luminosité de l'affichage LED, le réglage par défaut d'usine est uniquement "3", plus le paramètre est élevé, plus la luminosité est élevée. appuyez sur "x0" pour définir, il n'est pas recommandé de définir vous-même la valeur par défaut.

## Parameters settings

## 3.2.12 The linear scale counting frequency setting

The factory default setting is only "12", the higher the parameter, the lower the counting frequency, press "X0" to set, it is not recommended that you set the default value yourself.

## 3.2.13 Setting QUIT: Digital display table parameters quit button.

## 3.2.14 Setting the type of the DRO.

The type of the DRO will be display on the right window. then press the key **ENT** to select the correct type. the following system item will be set:

"MILL-3" means the DRO type is 3-axis milling machine table;

"MILL-2" means the DRO type is 2-axis milling machine table;

"LATHE-2" means the DRO type is 2-axis lathe table;

"LATHE-3" means the DRO type is 3-axis lathe table;

"GRIND" means the DRO type is Grind table;

"EDM" means the DRO type is EDM table; (Special customization function, if you need to buy, please contact the dealer to customize)

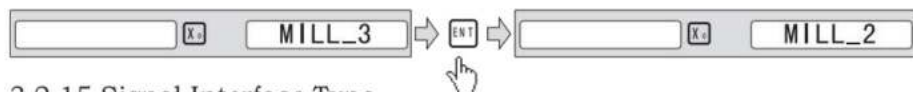

## 3.2.15 Signal Interface Type

Message window displays "SEL AXIS" which indicates the step is to Sensor input signal mode. Press **X0** to change the signal mode for X axis; Press **Y0** to change the signal mode for Y axis; Press **Z0** to change the signal mode for Z axis; Example for X axis:

Press **X0** to scroll through the Rotary encode type, the Linear encode type, the Rotary rdius type.

X window displays the Signal type.

"LInER" means the Signal type is linear encode type ;

"EnCoDE " means the Signal type is Rotary encode type;

"RdIUS" means the Signal type is Rotary rdius type ;

Example: currently in the linear encode type, to toggle to the Rotary encode type;

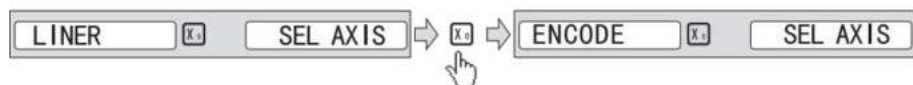

## Parameters settings

## 3.2.16 Restore Factory Settings:

Clear all data except DRO type. DRO will load default setup for parameter. After loading default setup, user must search RI once to enable resuming ABS datum function; otherwise to resume the datum by RI is unable;

Message window displays “ALL CLR”, press **ENT** and message windows display “PASSWORD” indicating the operator to input password; Press 2000 + **ENT** in turn to load default value;

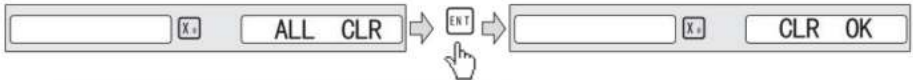

## 3.2.17 Shrinkage Ratio enable or disable.

Message window displays “SRK OFF” to disable Shrinkage rate function. Press **ENT** to enable Shrinkage rate function in Message window displays “SRK ON” :

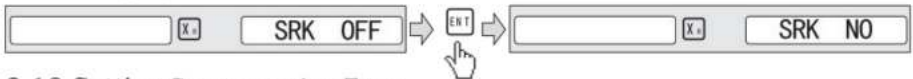

## 3.2.18 Setting Compensation Type

Message window displays “SEL COMP” which indicates the step is to compensation type. Press **X0** to change the compensation type for X axis; Press **Y0** to change the compensation type for Y axis; Press **Z0** to change the compensation type for Z axis; Example for X axis:

Press **X0** to scroll through the not compensation type, the Linear compensation type, the non-linear compensation type.

“no-CO” means the compensation type is not compensation type;

“LinE-CO” means the compensation type is linear compensation type.

“non-LinE” means the compensation type is non-linear linear compensation type;

Example for X axis: currently in the not compensation type, to toggle to the linear compensation type;

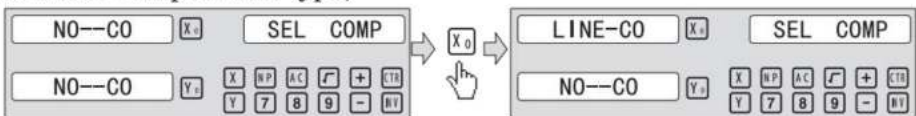

## Parameters settings

## 3.2.19 Inch display, set the number of digits after the decimal point

In the inch display mode, the number of digits after the decimal point is set, the factory default digit is "4", press "X0" to set, can be set according to actual needs.

3.2.20 Setting EDM: it is not recommended that you set the default value yourself, EDM function, Set the relay off on time.

## 3.2.21 Setting Linearity Compensation.

Message window displays "LIN COMP" which indicates the step is to Linearity Compensation. Compensate the linear error to make display value equals to standard value.

The calculation of compensation rectifying coefficient:

$$\text{Coefficient} = \frac{(\text{Measurement} - \text{Standard value}) \times 1000.000}{\text{Standard value}}$$

Example for X axis:

Measurement 200.020mm

Standard value 200.000mm

Rectifying coefficient= (200.020-200) \* 1000 /200 =-0.01mm/m

Input compensation rectifying coefficient 0.01 as follow:

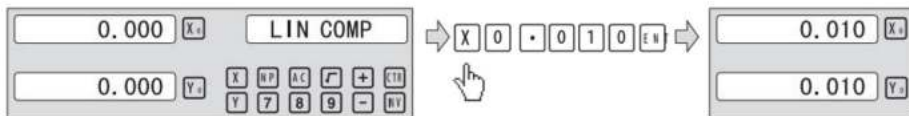

## 3.2.22 Setting the Shrinkage Ratio

Press until "SHRINK" appears in message window;

$$\text{Shrinkage ratio} = \frac{\text{Dimensions of the finished product}}{\text{Dimensions of the working piece}}$$

Set the shrinkage ratio 1.005 as follow;

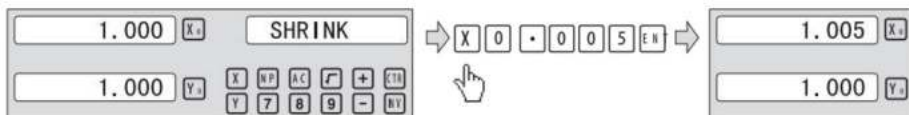







## General Operations

---

### 4、 General Operations;

#### 4.1 Zeroing



Zero the designated axis in normal display state. Zeroing is used to set the current position as datum point as follow;

key		<span style="border: 1px solid black; padding: 2px;">X<sub>0</sub></span>		X axis zero	<table style="width: 100%; border-collapse: collapse;"> <tr> <td style="width: 80%; border: 1px solid gray; padding: 2px;">0.000</td> <td style="width: 20%; border: 1px solid gray; padding: 2px;"><span style="border: 1px solid black; padding: 2px;">X<sub>0</sub></span></td> </tr> <tr> <td style="border: 1px solid gray; padding: 2px;">0.000</td> <td style="border: 1px solid gray; padding: 2px;"><span style="border: 1px solid black; padding: 2px;">Y<sub>0</sub></span></td> </tr> <tr> <td style="border: 1px solid gray; padding: 2px;">0.000</td> <td style="border: 1px solid gray; padding: 2px;"><span style="border: 1px solid black; padding: 2px;">Z<sub>0</sub></span></td> </tr> </table>	0.000	<span style="border: 1px solid black; padding: 2px;">X<sub>0</sub></span>	0.000	<span style="border: 1px solid black; padding: 2px;">Y<sub>0</sub></span>	0.000	<span style="border: 1px solid black; padding: 2px;">Z<sub>0</sub></span>
0.000	<span style="border: 1px solid black; padding: 2px;">X<sub>0</sub></span>										
0.000	<span style="border: 1px solid black; padding: 2px;">Y<sub>0</sub></span>										
0.000	<span style="border: 1px solid black; padding: 2px;">Z<sub>0</sub></span>										
key		<span style="border: 1px solid black; padding: 2px;">Y<sub>0</sub></span>		Y axis zero							
key		<span style="border: 1px solid black; padding: 2px;">Z<sub>0</sub></span>		Z axis zero							

X<sub>0</sub> or Y<sub>0</sub> or Z<sub>0</sub> will be return to the original data before the reset.

#### 4.2 Preset Data to Designated Axis



Preset a value to current position for a designated axis in normal display state.

<table style="width: 100%; border-collapse: collapse;"> <tr><td style="border: 1px solid gray; padding: 2px;">25.400</td><td style="border: 1px solid gray; padding: 2px;"><span style="border: 1px solid black; padding: 2px;">X<sub>0</sub></span></td></tr> <tr><td style="border: 1px solid gray; padding: 2px;">50.800</td><td style="border: 1px solid gray; padding: 2px;"><span style="border: 1px solid black; padding: 2px;">Y<sub>0</sub></span></td></tr> <tr><td style="border: 1px solid gray; padding: 2px;">76.200</td><td style="border: 1px solid gray; padding: 2px;"><span style="border: 1px solid black; padding: 2px;">Z<sub>0</sub></span></td></tr> </table>	25.400	<span style="border: 1px solid black; padding: 2px;">X<sub>0</sub></span>	50.800	<span style="border: 1px solid black; padding: 2px;">Y<sub>0</sub></span>	76.200	<span style="border: 1px solid black; padding: 2px;">Z<sub>0</sub></span>		<table style="width: 100%; border-collapse: collapse;"> <tr><td style="border: 1px solid gray; padding: 2px;">X</td><td style="border: 1px solid gray; padding: 2px;">1</td><td style="border: 1px solid gray; padding: 2px;">8</td><td style="border: 1px solid gray; padding: 2px;">0</td><td style="border: 1px solid gray; padding: 2px;">.</td><td style="border: 1px solid gray; padding: 2px;">0</td><td style="border: 1px solid gray; padding: 2px;">1</td><td style="border: 1px solid gray; padding: 2px;">0</td><td style="border: 1px solid gray; padding: 2px;">ENT</td></tr> <tr><td style="border: 1px solid gray; padding: 2px;">Y</td><td style="border: 1px solid gray; padding: 2px;">5</td><td style="border: 1px solid gray; padding: 2px;">8</td><td style="border: 1px solid gray; padding: 2px;">6</td><td style="border: 1px solid gray; padding: 2px;">.</td><td style="border: 1px solid gray; padding: 2px;">0</td><td style="border: 1px solid gray; padding: 2px;">1</td><td style="border: 1px solid gray; padding: 2px;">0</td><td style="border: 1px solid gray; padding: 2px;">ENT</td></tr> <tr><td style="border: 1px solid gray; padding: 2px;">Z</td><td style="border: 1px solid gray; padding: 2px;">8</td><td style="border: 1px solid gray; padding: 2px;">8</td><td style="border: 1px solid gray; padding: 2px;">8</td><td style="border: 1px solid gray; padding: 2px;">.</td><td style="border: 1px solid gray; padding: 2px;">6</td><td style="border: 1px solid gray; padding: 2px;">6</td><td style="border: 1px solid gray; padding: 2px;">0</td><td style="border: 1px solid gray; padding: 2px;">ENT</td></tr> </table>	X	1	8	0	.	0	1	0	ENT	Y	5	8	6	.	0	1	0	ENT	Z	8	8	8	.	6	6	0	ENT		<table style="width: 100%; border-collapse: collapse;"> <tr><td style="border: 1px solid gray; padding: 2px;">180.010</td><td style="border: 1px solid gray; padding: 2px;"><span style="border: 1px solid black; padding: 2px;">X<sub>0</sub></span></td></tr> <tr><td style="border: 1px solid gray; padding: 2px;">586.010</td><td style="border: 1px solid gray; padding: 2px;"><span style="border: 1px solid black; padding: 2px;">Y<sub>0</sub></span></td></tr> <tr><td style="border: 1px solid gray; padding: 2px;">888.660</td><td style="border: 1px solid gray; padding: 2px;"><span style="border: 1px solid black; padding: 2px;">Z<sub>0</sub></span></td></tr> </table>	180.010	<span style="border: 1px solid black; padding: 2px;">X<sub>0</sub></span>	586.010	<span style="border: 1px solid black; padding: 2px;">Y<sub>0</sub></span>	888.660	<span style="border: 1px solid black; padding: 2px;">Z<sub>0</sub></span>
25.400	<span style="border: 1px solid black; padding: 2px;">X<sub>0</sub></span>																																										
50.800	<span style="border: 1px solid black; padding: 2px;">Y<sub>0</sub></span>																																										
76.200	<span style="border: 1px solid black; padding: 2px;">Z<sub>0</sub></span>																																										
X	1	8	0	.	0	1	0	ENT																																			
Y	5	8	6	.	0	1	0	ENT																																			
Z	8	8	8	.	6	6	0	ENT																																			
180.010	<span style="border: 1px solid black; padding: 2px;">X<sub>0</sub></span>																																										
586.010	<span style="border: 1px solid black; padding: 2px;">Y<sub>0</sub></span>																																										
888.660	<span style="border: 1px solid black; padding: 2px;">Z<sub>0</sub></span>																																										



#### 4.3 Toggle Display Unit between inch and mm

Length can be displayed either in “mm” (metric) or “inch” (imperial). Display unit can be toggled between mm and inch.

Example: Display value toggle from mm to inch;

<table style="width: 100%; border-collapse: collapse;"> <tr><td style="border: 1px solid gray; padding: 2px;">25.400</td><td style="border: 1px solid gray; padding: 2px;"><span style="border: 1px solid black; padding: 2px;">X<sub>0</sub></span></td></tr> <tr><td style="border: 1px solid gray; padding: 2px;">50.800</td><td style="border: 1px solid gray; padding: 2px;"><span style="border: 1px solid black; padding: 2px;">Y<sub>0</sub></span></td></tr> <tr><td style="border: 1px solid gray; padding: 2px;">76.200</td><td style="border: 1px solid gray; padding: 2px;"><span style="border: 1px solid black; padding: 2px;">Z<sub>0</sub></span></td></tr> </table>	25.400	<span style="border: 1px solid black; padding: 2px;">X<sub>0</sub></span>	50.800	<span style="border: 1px solid black; padding: 2px;">Y<sub>0</sub></span>	76.200	<span style="border: 1px solid black; padding: 2px;">Z<sub>0</sub></span>	mm		<span style="border: 1px solid black; padding: 2px;">mm inch</span>			inch	<table style="width: 100%; border-collapse: collapse;"> <tr><td style="border: 1px solid gray; padding: 2px;">1.0000</td><td style="border: 1px solid gray; padding: 2px;"><span style="border: 1px solid black; padding: 2px;">X<sub>0</sub></span></td></tr> <tr><td style="border: 1px solid gray; padding: 2px;">2.0000</td><td style="border: 1px solid gray; padding: 2px;"><span style="border: 1px solid black; padding: 2px;">Y<sub>0</sub></span></td></tr> <tr><td style="border: 1px solid gray; padding: 2px;">3.0000</td><td style="border: 1px solid gray; padding: 2px;"><span style="border: 1px solid black; padding: 2px;">Z<sub>0</sub></span></td></tr> </table>	1.0000	<span style="border: 1px solid black; padding: 2px;">X<sub>0</sub></span>	2.0000	<span style="border: 1px solid black; padding: 2px;">Y<sub>0</sub></span>	3.0000	<span style="border: 1px solid black; padding: 2px;">Z<sub>0</sub></span>
25.400	<span style="border: 1px solid black; padding: 2px;">X<sub>0</sub></span>																		
50.800	<span style="border: 1px solid black; padding: 2px;">Y<sub>0</sub></span>																		
76.200	<span style="border: 1px solid black; padding: 2px;">Z<sub>0</sub></span>																		
1.0000	<span style="border: 1px solid black; padding: 2px;">X<sub>0</sub></span>																		
2.0000	<span style="border: 1px solid black; padding: 2px;">Y<sub>0</sub></span>																		
3.0000	<span style="border: 1px solid black; padding: 2px;">Z<sub>0</sub></span>																		

Example: Display value toggle from inch to mm;

<table style="width: 100%; border-collapse: collapse;"> <tr><td style="border: 1px solid gray; padding: 2px;">1.0000</td><td style="border: 1px solid gray; padding: 2px;"><span style="border: 1px solid black; padding: 2px;">X<sub>0</sub></span></td></tr> <tr><td style="border: 1px solid gray; padding: 2px;">2.0000</td><td style="border: 1px solid gray; padding: 2px;"><span style="border: 1px solid black; padding: 2px;">Y<sub>0</sub></span></td></tr> <tr><td style="border: 1px solid gray; padding: 2px;">3.0000</td><td style="border: 1px solid gray; padding: 2px;"><span style="border: 1px solid black; padding: 2px;">Z<sub>0</sub></span></td></tr> </table>	1.0000	<span style="border: 1px solid black; padding: 2px;">X<sub>0</sub></span>	2.0000	<span style="border: 1px solid black; padding: 2px;">Y<sub>0</sub></span>	3.0000	<span style="border: 1px solid black; padding: 2px;">Z<sub>0</sub></span>	inch		<span style="border: 1px solid black; padding: 2px;">mm inch</span>			mm	<table style="width: 100%; border-collapse: collapse;"> <tr><td style="border: 1px solid gray; padding: 2px;">25.400</td><td style="border: 1px solid gray; padding: 2px;"><span style="border: 1px solid black; padding: 2px;">X<sub>0</sub></span></td></tr> <tr><td style="border: 1px solid gray; padding: 2px;">50.800</td><td style="border: 1px solid gray; padding: 2px;"><span style="border: 1px solid black; padding: 2px;">Y<sub>0</sub></span></td></tr> <tr><td style="border: 1px solid gray; padding: 2px;">76.200</td><td style="border: 1px solid gray; padding: 2px;"><span style="border: 1px solid black; padding: 2px;">Z<sub>0</sub></span></td></tr> </table>	25.400	<span style="border: 1px solid black; padding: 2px;">X<sub>0</sub></span>	50.800	<span style="border: 1px solid black; padding: 2px;">Y<sub>0</sub></span>	76.200	<span style="border: 1px solid black; padding: 2px;">Z<sub>0</sub></span>
1.0000	<span style="border: 1px solid black; padding: 2px;">X<sub>0</sub></span>																		
2.0000	<span style="border: 1px solid black; padding: 2px;">Y<sub>0</sub></span>																		
3.0000	<span style="border: 1px solid black; padding: 2px;">Z<sub>0</sub></span>																		
25.400	<span style="border: 1px solid black; padding: 2px;">X<sub>0</sub></span>																		
50.800	<span style="border: 1px solid black; padding: 2px;">Y<sub>0</sub></span>																		
76.200	<span style="border: 1px solid black; padding: 2px;">Z<sub>0</sub></span>																		

## General Operations

### 4.4 Absolute/Incremental/200 groups SDM

Function: The DRO has 3 coordinate display modes: the absolute mode (ABS); the incremental mode (INC) and 200 groups Second Data Memory (SDM) with the range of 00 to 99. Zero point of work-piece is set at the origin point of ABS coordinate. The relative distance between datum of ABS and SDM remains unchanged when ABS datum is changed.

1. Toggle from ABS to INC coordinate;

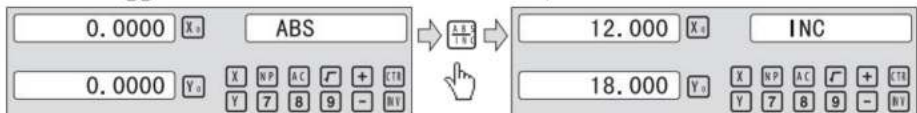

2. Toggle from INC to ABS coordinate;

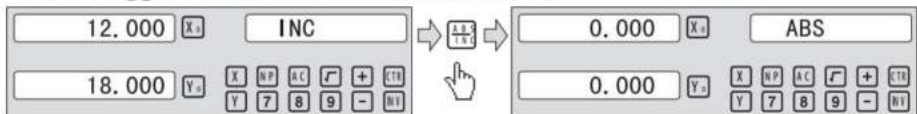

3. Toggle from SMD to ABS coordinate;

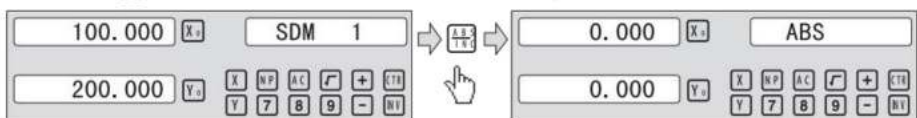

### 4.5 1/2 Function

Function: Set the center of work piece as datum by halving the displayed value.

Example: Set the center of rectangle as datum as the right figure.

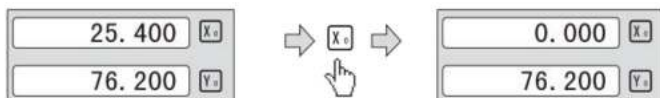
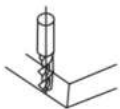

Steps:

1. Touch one side of the workpiece with the TOOL, then zero the X axis.



## Opérations générales

2 Amenez l'OUTIL sur le côté opposé de la pièce et touchez-le.

Appuyez ensuite sur  +  à son tour pour évaluer la valeur d'affichage de l'axe X.

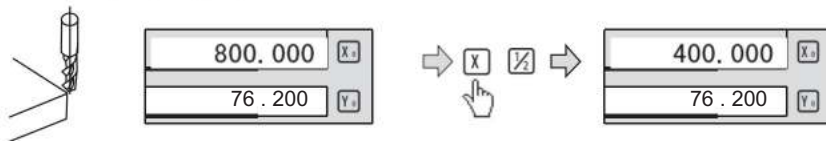



3. Déplacez la table de correspondance jusqu'à ce que « 0.000 » s'affiche sur l'axe des x fenêtre. La position est le centre de la pièce à usiner.

4. 6 Effacer toutes les données SDM.

En mode AB, pour appuyer en continu  dix fois suffiront à effacer toutes les données pour 200 ensembles SDM. La fenêtre Message affiche "CLR".

4. 7 Mode veille

en mode non ABS, en appuyant sur la touche  Can éteint tout l'affichage et le DRO accède au mode veille, puis en appuyant sur cette touche à nouveau, le DRO reviendra au mode de fonctionnement. En mode veille Mode le DRO est toujours en état de fonctionnement et enregistre réellement l'OUTIL **movement**.

Exemple : en mode non ABS, pour accéder au mode veille, appuyez sur la touche F  En mode veille, appuyez sur la touche F pour quitter le 

Mode veille ·

4. 8 Mémoire d'interruption de puissance.

La mémoire est utilisée pour stocker les paramètres du DRO et de la machine valeurs de référence lorsque l'alimentation est coupée.

## Opérations générales

## 4. 9 rechercher le point de référence absolu de l'échelle

Au cours du processus d'usinage quotidien, il est très courant que le l'usinage ne peut pas être terminé en un seul quart de travail, et donc Les DRO doivent être éteints après le travail, sinon une panne de courant se produit pendant le processus d'usinage qui conduit à la perte de la référence de la pièce (position zéro de la pièce) , le rétablissement de la référence de la pièce l'utilisation d'un détecteur de bord ou d'une autre méthode induit inévitablement des valeurs plus élevées usinage avec précision car il n'est pas possible de rétablir la référence de la pièce exactement à la position précédente. POUR permettre à récupération précise du repère de la pièce et pas besoin de rétablir le repère de la pièce à l'aide d'un détecteur de bord ou d'autres méthodes, chaque échelle linéaire possède un emplacement de point de référence qui est équipé d'une référence position pour fournir une fonction de mémoire de point de référence.

Le principe de fonctionnement de la fonction de mémoire de référence est le suivant suit.

étant donné que le point de référence de l'échelle linéaire est permanent et fixe, il ne change jamais ou ne disparaît jamais lorsque le système DRO est éteint. Par conséquent, nous devons simplement stocker la distance entre le point de référence et la référence de la pièce (position zéro) dans la mémoire NON volatile · Ensuite en cas de panne de courant ou de DRO éteint, nous pouvons récupérer la référence de la pièce (position zéro) en pré réglant le zéro de l'affichage position comme la distance enregistrée à partir du point de référence ·

Une référence absolue doit être définie lors de l'usinage d'une pièce. Il existe trois modes de fonctionnement (REF, AB, LEF AB) :

Exemple : pour stocker la référence de travail de l'axe X·

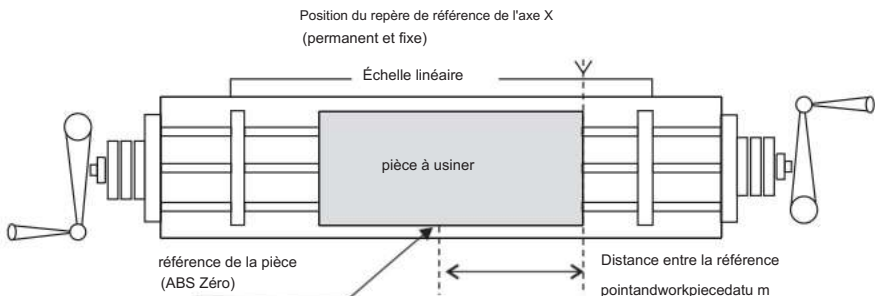

## General Operations

### Example for REF mode :

1、DRO is set in ABS coordinate. Press **REF**, then the message window display “REF” .

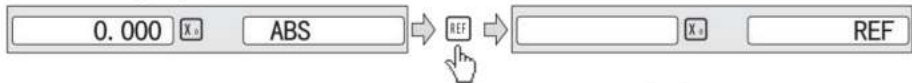

2、Message window displays “REF” , Press **ENT** until “FD\_REF” appears in message window.

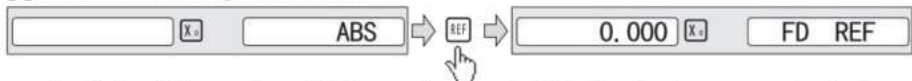

3、Select the axis which need search RI. For instance : select X axis, then press **X** . “X\_REF” is displayed in message window, and X axis window flashes.

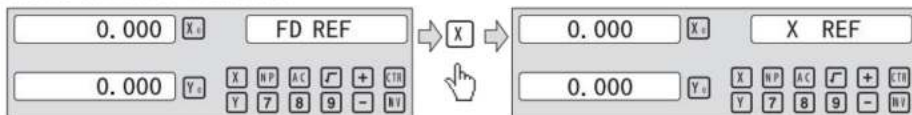

4、Move the machine table .The buzzer sounds when RI is searched, then X window stops flashing and displays the value of the current position .the DRO returns normal display state. Then message window displays “FIND\_X” .

### Example for AB mode :

1、DRO is set in ABS coordinate. Press **REF**, then the message window display “REF” .

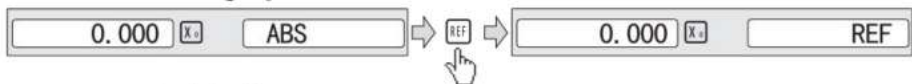

2、Press **▲ ▼**, then the message window display “AB” .

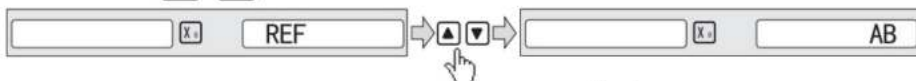

3、Message window displays “AB” , Press **ENT** until “FIND\_AB” appears in message window.

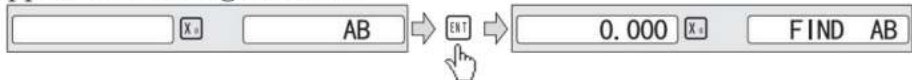

## General Operations

4、 Select the axis which need search RI. For instance : selct X axis, then press **X** . “X\_REF” is displayed in message window, and X axis window flashes.

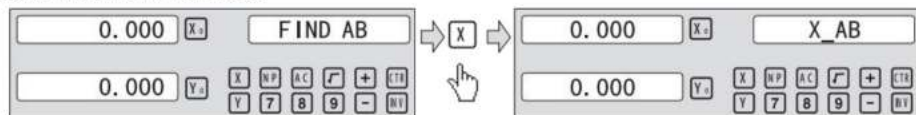

5、 Move the machine table .The buzzer sounds when RI is searched, displays the value of the current position for the absolute datum zero. the DRO returns normal display state. Then message window displays “FIND\_AB” .

### Example for LEF\_AB mode :

1、 DRO is set in ABS coordinate. Press **REF** , then the message window display “REF” .

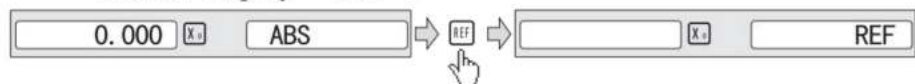

2、 Press **▲** **▼** , then the message window display “AB” .

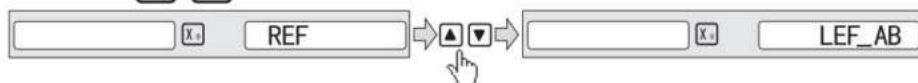

3、 Message window displays “LEF\_AB” , Press **ENT** until “ZERO\_AB” appears in message window.

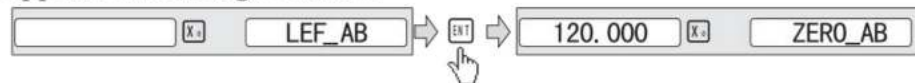

4、 Move the machine table to be set zero position piont. then press **X** , X axis will be zeroing . the current position for the absolute datum zero. the DRO returns normal display state.

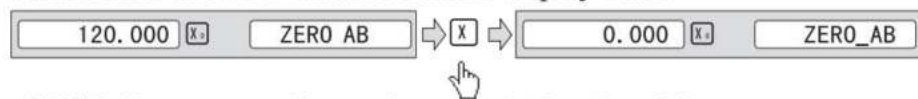

NOTE: Linear range without reference point location of the user

## General Operations

### 4.10 Non Linear Error Compensation

First compensation Type ( Linear or Non-Linear) in parameter setting must be set Non-Linear. Linear scale have a ref point location and find to the Absolute Reference Point will be enable.

Default Non-Linear compensation : 50.

#### Example for Y axis:

Step 1: Search the Absolute Reference Point of Scale;

Step 2: Press **[NP]** , then the message window display “COMP X” .



Step 3: Press **[▲]** **[▼]**, then the message window display “COMP Y”



Step 4: Press **[ENT]**, then the message window display “NUMBER” .

Then input the compensation parameter NUMBER.



Step 5: Press **[▲]** **[▼]**, then message window displays “Y-MSN-1” which indicates the step is to Non Linear Error Compensation.

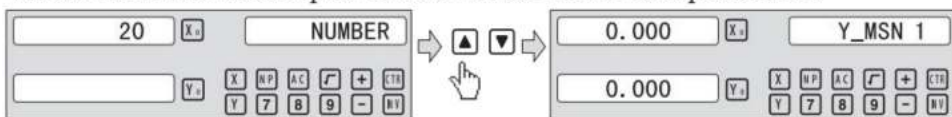

Step 6: Input compensation value .

X window display the value of the measurement value.

Y window display the value of the standard value.

Example for the first compensation point:

Measurement value :68.288mm. Standard value: 68.200mm



Step 7: After input all parameter, the DRO automatically exit.

## 5、 200 Groups SDM coordinate

The DRO has three display modes: the absolute mode (ABS), the incremental mode (INC) and the 200 groups second data memory (SDM 1 – SDM200). ABS datum of the work-piece is set at the beginning and the 200 groups SDM is set relative to ABS coordinate.

ABS Mode, INC Mode and SdM Mode are specially designed to provide much more convenience features to the operator to cope with the batch machining of relative works and the machining of the workpiece machining dimensions from more than one datum.

**Example:** The ABS datum is the center point O, the point sdm1, sdm2, sdm3, sdm4 needed processing are set as datum of SDM 1 – SDM 4.

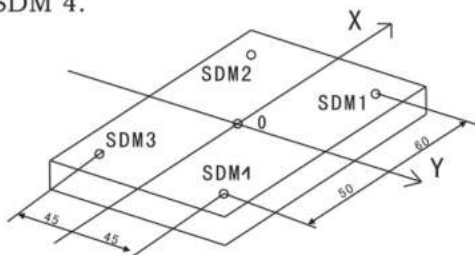

Two ways to set SDM coordinate:

- 1、 Zeroing at the Current Point.
- 2、 Preset datum of SDM coordinate.

### 5.1 Zeroing at the Current Point

At first set the center point of the work-piece as the origin of the ABS, then align the TOOL with point SDM1,SDM2,SDM3,SDM4 by moving the machine table and zero them. It is the position to process where the “0.000” appears in X window, Y window by moving the machine table whether in ABS or in SDM coordinate.

#### Steps:

- 1、 Move worktable to place the TOOL at the center of the workpiece point O as the datum of ABS. Then zero X axis and Y axis in SDM 1 ; Zero X axis and Y axis in SDM 2 ; Zero X axis and Y axis in SDM 3 ; Zero X axis and Y axis in SDM 4.

## 200 Groups SDM coordinate

2、 Set the point sdm1 as the datum of SDM 1. Move the machine worktable to  $x = 60.000$ ,  $y = 45.000$ . Then proess  $X_0$   $Y_0$ .

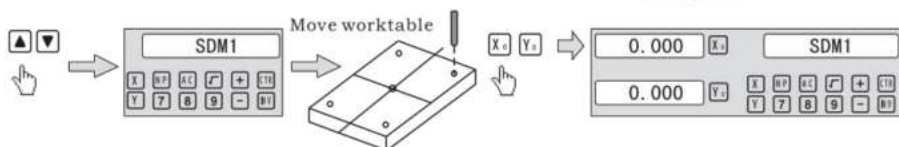

2、 Set the point sdm1 as the datum of SDM 2. Move the machine worktable to  $x = 60.000$ ,  $y = -45.000$ . Then proess  $X_0$   $Y_0$ .

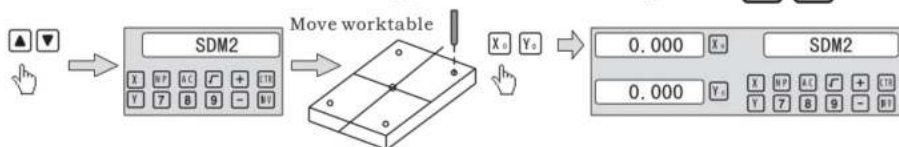

3、 Set the point sdm1 as the datum of SDM 3. Move the machine worktable to  $x = -60.000$ ,  $y = -45.000$ . Then proess  $X_0$   $Y_0$ .

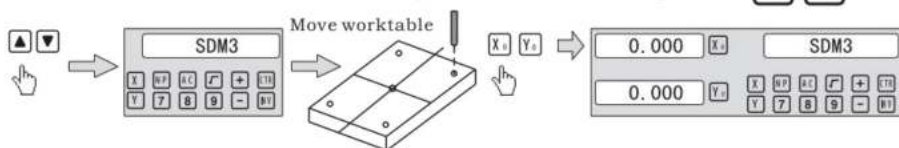

4、 Set the point sdm1 as the datum of SDM 4. Move the machine worktable to  $x = -60.000$ ,  $y = 45.000$ . Then proess  $X_0$   $Y_0$ .

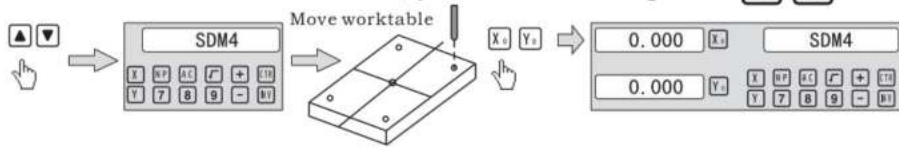

## 5.2 Preset datum of SDM coordinate

There are the same sample as Method 1. First Move the worktable to place the TOOL exactly at the origin of ABS, secondly Enter the ABS Mode as follow.

### Steps:

1、 Move worktable to place the TOOL at the center of the workpiece point O as the datum of ABS. Then zero X axis and Y axis in SDM 1 ; Zero X axis and Y axis in SDM 2 ; Zero X axis and Y axis in SDM 3 ; Zero X axis and Y axis in SDM 4.

## 200 Groups SDM coordinate

2、 Set point sdm1 as the datum of SDM 1. Press  $\blacktriangle$   $\blacktriangledown$ , then the message window display “SDM 1” . Input x = 60.000, y = 45.000.

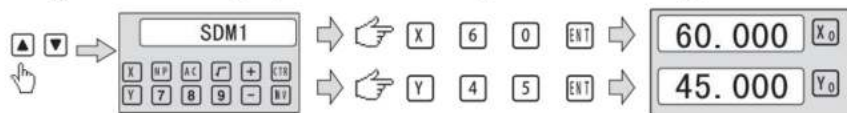

3、 Set point sdm1 as the datum of SDM 2. Press  $\blacktriangle$   $\blacktriangledown$ , then the message window display “SDM 2” . Input x = -60.000, y = 45.000.

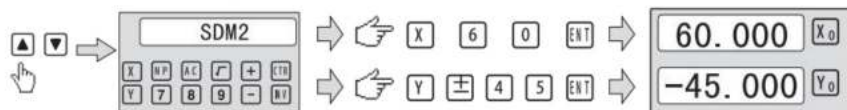

4、 Set point sdm1 as the datum of SDM 3. Press  $\blacktriangle$   $\blacktriangledown$ , then the message window display “SDM 3” . Input x = -60.000, y = -45.000.

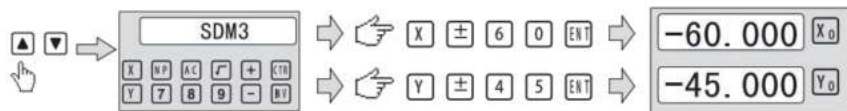

5、 Set point sdm1 as the datum of SDM 4. Press  $\blacktriangle$   $\blacktriangledown$ , then the message window display “SDM 4” . Input x = -60.000, y = 45.000.

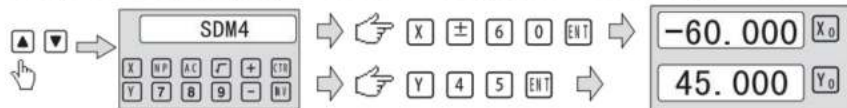

## 6. Fonction spéciale

## Circumference Holes Processing

### 6.1 Circumference Holes Processing

The Function of PCD Hole positioning on Circumference is used to distribute arc equally, such as boring hole on flange. The right window will show the parameter to be defined when selecting PCD Function.

The Parameters to be defined are:

PCD_XY(XZ,YZ)	Select place
CENTER	Center position
DIA	Diameter of circle
NO_HOLE	Hole number
ST ANG	Starting angle
ED ANG	Ending angle

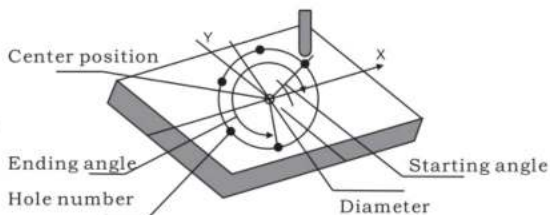

The position of the hole center are calculated automatically after input all parameters. Press or to choose the hole No. and move the machine table until the “0.000” appears in X window , Y window, Z window. It is the position to process a table.

Example for the XY place: Machine hole on circumference as the figure

PCD_XY(XZ,YZ)	XY
CENTER	X=0,000,Y=0.000
DIA	100,000
NO_HOLE	5
ST ANG	30,000
ED ANG	315,000

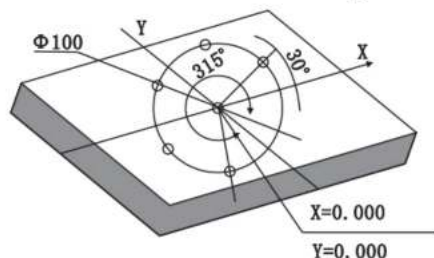

Steps:

1. Set display unit to metric in normal state; Move the machine table until the machine TOOL is aligned with the center of the circle , then zero X axis ,Y axis.

2. Select place.

Press , then the message window display “PCD\_XY” to the Circumference Holes Processing. Press or to select XY place.



## Circumference Holes Processing

## 2. Input center position.

Press **[ENT]**, then the message window display “CENTER”. X and Y window displays the formerly preset center position. Input X = 0, Y = 0 as follow.

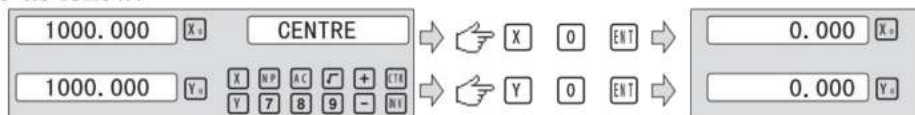

## 4. Input diameter.

Press **[▼]** until “DIA” appears in the message window. X window displays the formerly preset diameter. Then input the diameter is 100.000.

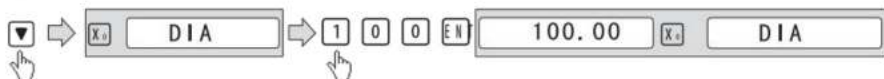

## 5. Input number.

Press **[▼]** until “NO\_HOLE” appears in the message window. X window displays the formerly preset number. Then press **[5]** in turn to input number.



## 6. Input starting angle.

Press **[▼]** until “ST ANG” appears in the message window. X window displays the formerly preset the starting angle. Then press **[3]** **[0]** in turn to input the starting angle.



## 7. Input ending angle.

Press **[▼]** until “ED ANG” appears in the message window. X window displays the formerly preset the ending angle.. Then press **[3]** **[1]** **[5]** in turn to input the ending angle.

## Circumference Holes Processing

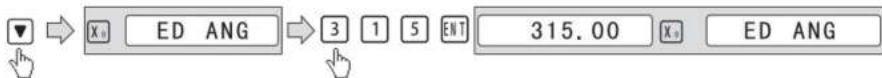

8. Press until “NO 1” appears in the message window.

It is the position of the first hole to punch where the “0.000” is displayed in X window and Y window by moving the machine table.

After finishing the first hole, press or to change holes number.

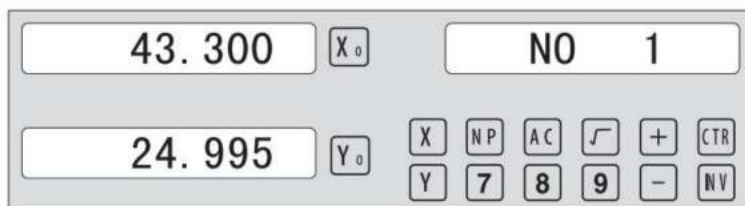

9. After processing all holes, press to return normal display.

## Linear Holes Processing

### 6.2 Linear Holes Processing

There are two modes to carry out the linear drilling: Length mode and Step mode.

1.LINE S	Step mode
LINE L	Length mode
2.STEP	Step length
LENGTH	Line length
3. ANG	Angle
4. NO.HOLE	Hole number

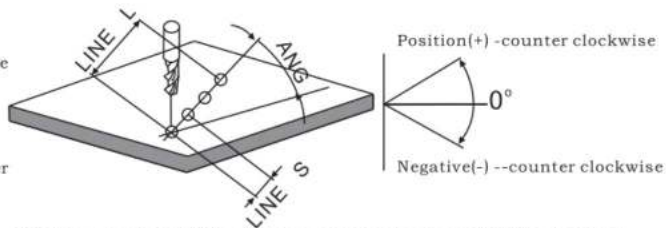

Linear Holes function can simplify the processing multiple holes whose centers are attributed equally on one line.

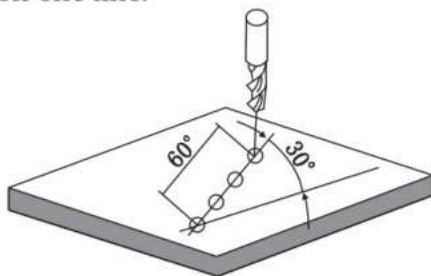

Example :

LINE_L	Length mode
LENGTH	60.000
ANG	30.000
NO.HOLE	4





Steps :

1. Select piece.

Press , then the message window display "LINE\_XY" to the Linear Holes Processing. Press  or  to select XY place.



2. Select Linear Holes mode.

Press , then the message window display "LINE\_S". Press  or  to select "LINE\_L".



3. Input linear length;

Press , then the message window display "LENGTH".

## Linear Holes Processing

X window displays the formerly preset the linear length. Press **6** **0** in turn to input the linear length.

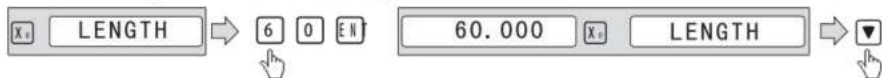

## 4. Input angle;

Message window displays “ANG” which indicates the step is to angle. X window displays the formerly preset the angle. Press **3** **0** in turn to input the angle.



## 5. Input number;

Message window displays “ANG” which indicates the step is to angle. X window displays the formerly preset the number. Press **4** in turn to input the number.

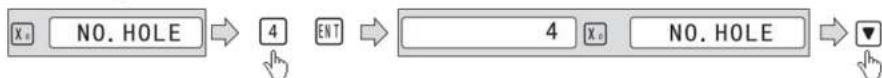

6. Press **▼** until “NO 1” appears in the message window.

It is the position of the first hole to punch where the “0.000” is displayed in X window and Y window by moving the machine table. After finishing the first hole, press **▲** or **▼** to change holes number.

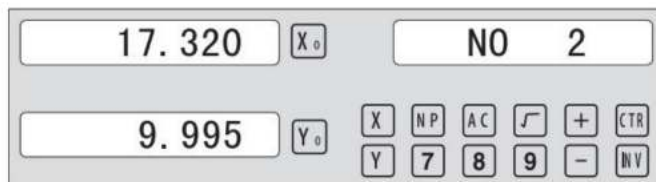

7. After processing all holes, press **☎** to return normal display.

## 6.3 Traitement ARC

DEUX fonctions sont disponibles pour la fonction ARC : l'ARC simple

Fonction et fonction R lisse : appuyez puis pr css



pour accéder à la fonction ARC,



ou pour sélectionner la fonction ARC lisse ou simple

Fonction ARC.

Lors de l'installation, normalement les coordonnées de la machine et de la direction de X, Y, Z sont comme suit. Le plan de travail est représenté comme le chiffre de droite.

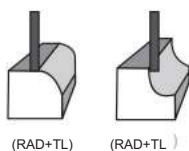

Z (+ direction positive)

Y (+ sens positif)



X (+ direction positive)

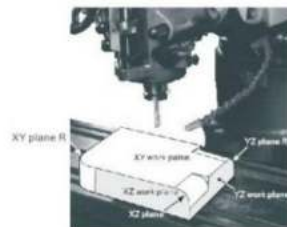

Fonction ARC simple :

lorsque la douceur n'est pas très demandée, le SIMPLE ARC

La fonction est normalement utilisée pour l'usinage d'arcs. Dans la fonction SIMPLE

il n'y a que huit types d'ARC utilisés pour l'usinage. L'opérateur vient

sélectionner le type de R et entrez les paramètres du rayon de l'arc

MAX CUT et Rqc extérieur ou arc intérieur. En général, un arc peut être

usiné par une fente plane T dans un OOL Ou arc TOOL, la différence entre plan de travail différent comme indiqué ci-dessous :

1	SIMPLE	traitement simple
2	TYPE 1 - 8	Mode de l'ARC.
3、	SEL_XY(XZ, YZ)	sélectionner un lieu Rayon de l'arc
4	RAD	Diamètre de l'outil
5	TLHIM	Étape d'alimentation
6.	COUPE MAXIMALE	arc extérieur et
7	RADTL	arc intérieur
		(uniquement pour la place xy)

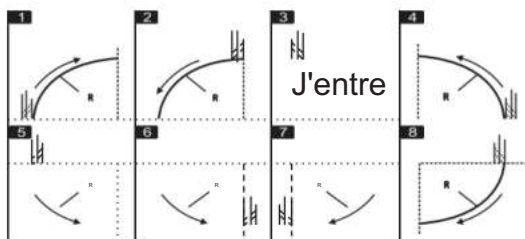

**Smooth ARC function :**

Provides maximum flexibility in ARC machining, the ARC sector to be machined by the coordinates of ARC. Very flexible, ARC function can machine virtually all kinds of ARC, ever the intersected ARC. Relatively a bit complicated to operate, operator need to calculate and enter the coordinates of ARC centre, start angle and end angle.

Basic parameter as follow:

1. SMOOTH	Mode of the Smooth ARC processing;
2. SEL_XY(YZ, XZ)	Select place;
3. CENTER	Refer to the position of an center.
4. RAD	Radius of the ARC
5. TL_DIA	Diameter of the TOOL
6. MAX_CUT	Feed step
7. ST_ANG	Starting angle
8. ED_ANG	Ending angle
9. RAD+TL	Outer arc.
RAD-TL	Inner arc.

**Example 1 for the Simple ARC Processing:**

Parameters settings as follow:

SIMPLE	Simple mode
TYPE	3
SEL_XY	XY
RAD	80.000
TL_DIA	6.000
MAX_CUT	0.500
RAD+TL	1

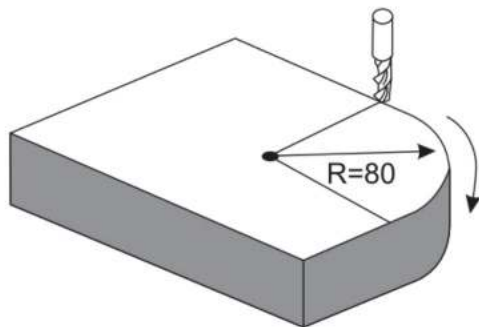
**Steps:**

1. Select process mode

Press  , then the message window display “SIMPLE” to the ARC Processing. Press  or  to select mode of the simple, The message window display “SIMPLE”

## ARC Processing



2. Input the type:

Press **ENT** until “TYPE” appears in the message window. X-window displays the formerly preset type. Press **3** in turn



3. Select place

Press **ENT** until “SEL\_XY” appears in the message window.

Press **▲** or **▼** to select place to display “SEL\_XY”;

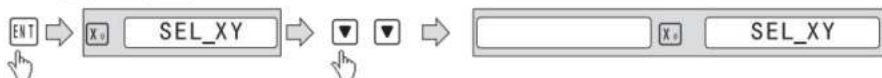

4. Input radius:

Press **ENT** until “RAD” appears in the message window. X-window displays the formerly preset radius of ARC. Press **80** in turn to input the radius.;

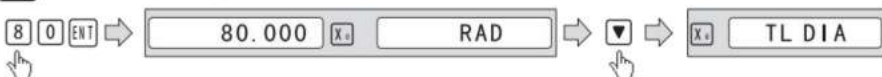

5. Input Diameter of the TOOL

Press **▲** or **▼** until “TL DIA” appears in the message window. X-window displays the formerly preset Diameter of the TOOL. Press **6** in turn to input the Diameter value;



6. Input Feed step (MAX\_CUT);

Press **▲** or **▼** until “MAX\_CUT” appears in the message window. X-window displays the formerly preset MAX\_CUT. Press **0.5** in turn to input the MAX\_CUT value;



## ARC Processing

## 7. Select outer arc or inner arc

Press or until “RAD-TL” appears in the message window. Press or to select place to display “RAD+TL” ;

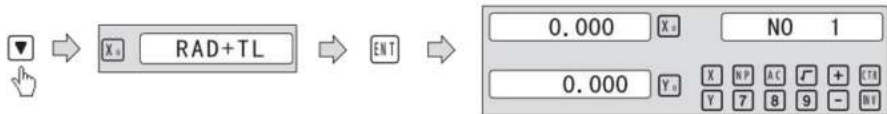

## 8. After inputting all parameters, press the key for machining.

The DRO will display the position of the first point. Retract the axes until the displays read 0.000, Machine the Arc point by point in accordance with the display. After finishing the position of the first point, press or to change position point.

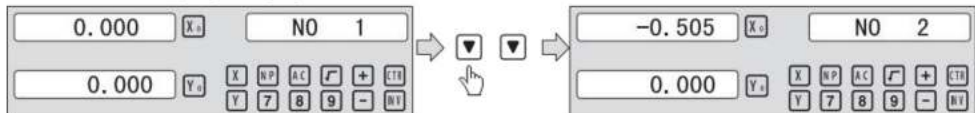

Press to quit R function any time.

**Example 2 for the Simple ARC Processing:**

Parameters settings as follow:

SIMPLE	Simple mode
TYPE	3
SEL_XY	XZ .....
RAD	80.000 .....
TL_DIA	6.000 .....
MAX_CUT	0.500 .....

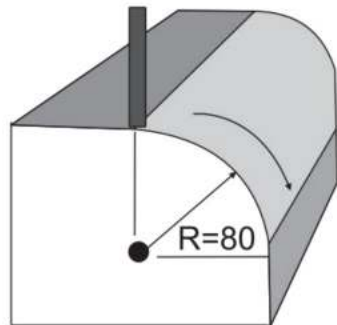

Steps:

1. Press , then the message window display “SIMPLE” to the ARC Processing. Press or to select mode of the simple, The message window display “SIMPLE”

## ARC Processing



2. Input the type:

Press **ENT** until “TYPE” appears in the message window. X-window displays the formerly preset type. Press **3** in turn



3. Select place

Press **ENT** until “SEL\_XZ” appears in the message window.

Press **▲** or **▼** to select place to display “SEL\_XZ” ;



4. Input radius:

Press **ENT** until “RAD” appears in the message window. X window displays the formerly preset the radius of ARC. Press **80** in turn to input the radius.;



5. Input Diameter of the TOOL

Press **▲** or **▼** until “TL DIA” appears in the message window. X window displays the formerly preset the Diameter of the TOOL. Press **6** in turn to input the Diameter value;



6. Input Feed step (MAX\_CUT);

Press **▲** or **▼** until “MAX\_CUT” appears in the message window. X window displays the formerly preset the MAX\_CUT. Press **0.5** in turn to input the MAX\_CUT value;



## ARC Processing

7. After inputting all parameters, press the key **ENT** for machining.

For 2-axis milling machine table, It is not installed with Z-axis, please press **▲** or **▼** to simulate position of Z-axis. Press **▲** simulate moving to the former process, and press **▼** simulate moving to the next process point.

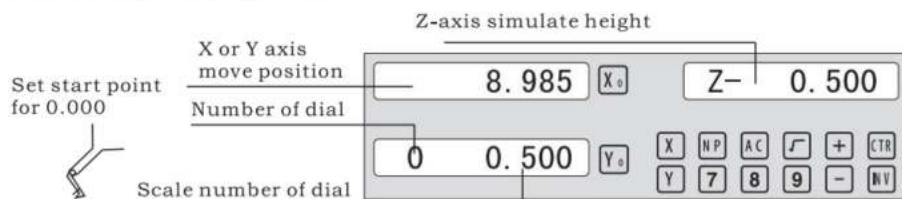

Z-axis simulate height = Number of dial x Z axis Dial + Scale number of dial

Press **▼** to quit R function any time.

### Example 3 for the Smooth ARC function:

Parameters settings as follow:

SMOOTH	Smooth mode
SEL_XY(YZ,XZ)	XY
CENTER	X=0,Y=0
RAD	80.000
TL_DIA	6.000
MAX_CUT	0.500
ST_ANG	0.000
ED_ANG	135.000
RAD+TL	1

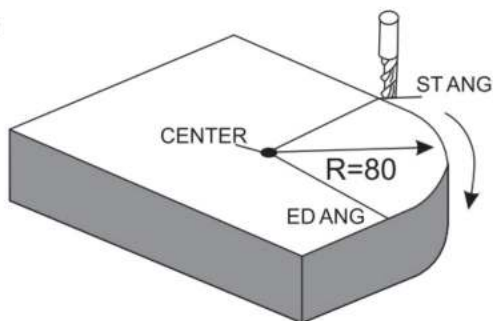

Steps:

1. Press **▼**, then the message window display "SIMPLE" to the ARC Processing. Press **▲** or **▼** to select mode of the simple, The

## ARC Processing

message window display “SMOOTH” ; For 3-axis milling machine table without this step. In second step. Then press **ENT** .



## 2. Select place

Message window display “SEL\_XY” which indicates the select is to place. Press **▲** or **▼** to select place to display “SEL\_XY” ;

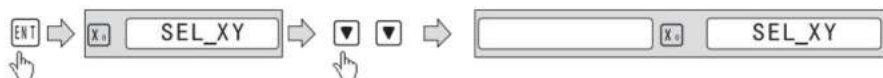

## 3. Input center position.

Press **ENT** , then the message window display “CENTER” . X and Y window displays the formerly preset center position. Input X = 0, Y = 0 as follow.

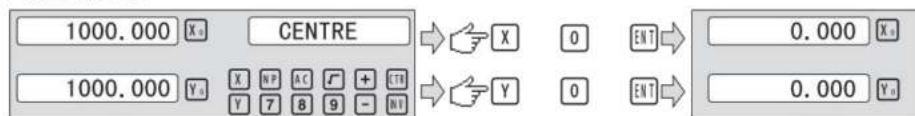

## 4. Input radius:

Press **ENT** until “RAD” appears in the message window. X window displays the formerly preset the radius of ARC. Press **8** **0** in turn to input the radius.;





## 5. Input Diameter of the TOOL



Press **▲** or **▼** until “TL DIA” appears in the message window. X window displays the formerly preset the Diameter of the TOOL. Press **6** in turn to input the Diameter value;



6. Étape d'alimentation d'entrée (MAX\_CUT) ;

presse  ou  jusqu'à ce que l'application UMAX CUT apparaisse dans le message

fenêtre. X Window de spa lys l'anciennement préréglé le MAX\_CUT. appuyez sur

   à son tour pour saisir la valeur MAX\_CUT ;



7. Angle de départ d'entrée .

presse  jusqu'à ce que "USTANG" apparaisse dans la fenêtre de message.x

fenêtre de spa lys l'ancien préréglage de l'angle de départ . Puis appuyez

 à son tour pour entrer l'angle de départ-

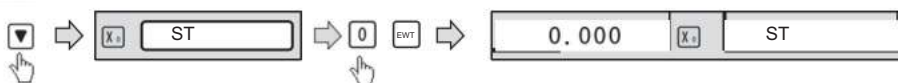



8. Angle de fin d'entrée .

presse  jusqu'à ce que « UED ANG » apparaisse dans la fenêtre de message. X



fenêtre ispa lys l'angle de fin précédemment prédéfini. Appuyez ensuite sur



  à son tour pour entrer l'angle de fin-



9. sélectionnez l'arc extérieur ou l'arc intérieur

appuyez  ou  jusqu'à ce que « RAD-TL » apparaisse dans le message

sur la fenêtre.appuyez sur  ou  pour sélectionner l'emplacement où afficher « RAD+TL » ;

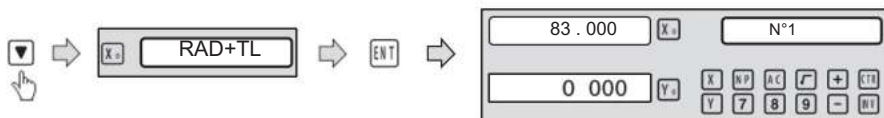

10. Après avoir saisi tous les paramètres,

**machining.**

Le DRO affichera la position du premier point. Rétractez le

axes jusqu'à ce que les écrans indiquent 0.000, usinez l'arc point par point dans conformément à l'affichage. Après avoir terminé la position du premier

pointer, appuyez  ou  pour changer de point de position.

## ARC Processing

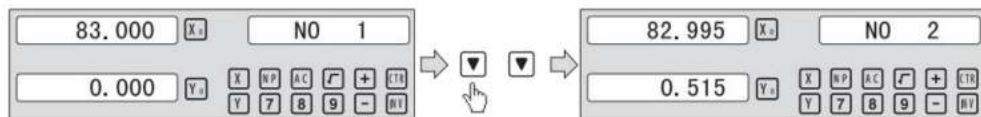

Press  to quit ARC function any time.

#### 6. 4 traitement oblique

Il existe 2 méthodes disponibles pour usiner un endroit oblique :

A). sur le lieu. b). sur le lieu yz, ou Xz ;

seuls les paramètres suivants doivent être saisis :

Y compris  $Xy(xz,yz)$  définir la machine à placer xy, yz, Orxz ·

LE L'angle d'inclinaison de l'oblique·

LÀ Le diamètre de l'OUTIL ·

SAINT-POT Position de départ;

ED PEUT Fin de la publication ;

Exemple 1 pour la place oblique xy :

lorsque le plan d'usinage est sur le plan xy comme la pièce représentée dans Figure, l'angle d'obliquité de la pièce doit être calibré avant que le plan oblique soit usiné. Par conséquent , à ce stade, le l'usinage du plan oblique joue le rôle de calibrage de l'obliquité ·

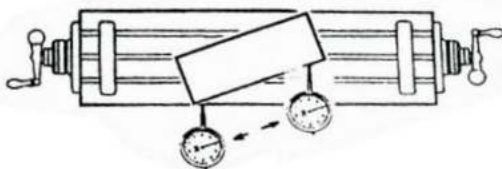

procédure d'étalonnage de l'obliquité

Placez d'abord la pièce sur la table de travail selon l'angle requis d'obliquité ·

1) Entrez la fonction du plan oblique. 2)

sélectionnez la fonction du plan XY ·

3) Entrez l'angle d'obliquité·

4) Déplacez la table de travail jusqu'à ce que l'outil de mesure (comme un comparateur à cadran) installé sur la fraiseuse touche le plan d'étalonnage d'obliquité, l'ajuste à zéro et déplace la table de travail sur n'importe quelle distance dans le direction de l'axe x.

5) Déplacez la table de travail à la distance de l'axe y jusqu'à ce que l'affichage tourne à zéro.



## Oblique Processing

---

6) Change the angle of the work piece to make the workpiece touch the measuring tool and adjust it to zero.

STEPS:



1. Select place

Press , then the message window display "INCL\_XY" to the Oblique Processing. Press  or  to select place to display "SEL\_XY";

Then press  to in next step;



2. Input the angle of obliquity

The message window display "ANG" , X window displays the formerly preset the angle of obliquity. Press   in turn to input the angle of obliquity .



3. Move the workpiece along the X-Axis until the measuring tool touches the workpiece adjust it to zero, and move the worktable for any distance along the X-Axis.



4. Press , display the value of Y-Axis. Move the workpiece along the Y-Axis, change the angle of workpiece to make the obliquity-calibrating plane touch the measuring tool until it turns to zero. Move the worktable until Y-Axis is displayed as zero.

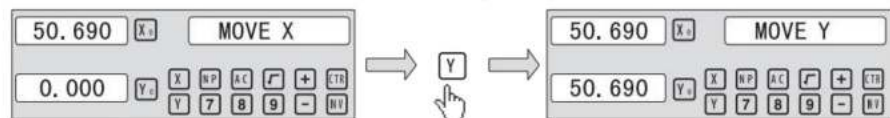

5. Press  to quit oblique function any time.

## Oblique Processing

### Example 2 for the oblique XZ or YZ place:

When the machining plane is on plane XZ or YZ, the function of TOOL inclination can instruct the operator to machine the oblique plane step by step.



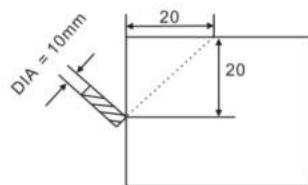
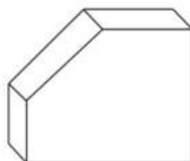

Procedures for using the function of cutter inclination:

When the machining plane is on plane XZ or YZ, first please calibrate the obliquity of the primary spindle nose and set the TOOL:

INCL_XY(XZ,YZ)	INCL_XZ
DIA	10.000
ST_POT	20.000
ED_POT	20.000





#### STEPS:

1. Press , then the message window display "INCL\_XY" to the oblique Processing. Press  or  to select place to display "SEL\_XZ; Then press  to in next step;



2. Input The TOOL Diameter

The message window display "DIA", X window displays the formerly preset the angle of obliquity. Press   in turn to input the TOOL Diameter of obliquity. OK, then press  to in next step;



3. Input ST\_POT;

The message window display "ST\_POT", X and Y window displays the formerly preset the stating position of obliquity. Input X= 0, Y = -20.000. OK, then press  to in next step;

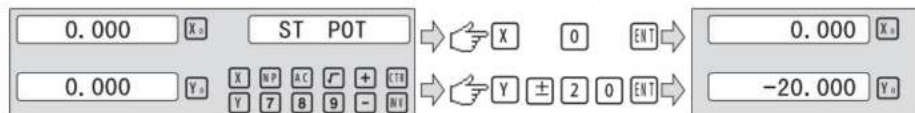



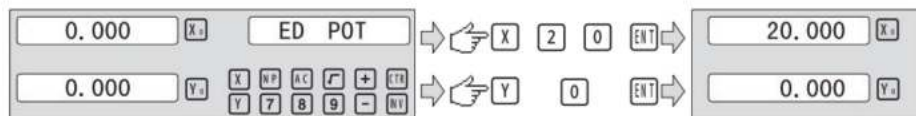

## Oblique Processing

### 4. Input ED\_POT;

The message window display “ED\_POT” , X and Y window displays the formerly preset the starting position of obliquity. Input X= 20.000, Y = 0.000 .



### 5. After input all parameter, press the key for machining.

For 2-axis milling machine table , It is not installed with Z-axis, please press  or  to simulate position of Z-axis. Press  simulate moving to the former process, and press  simulate moving to the next process point.

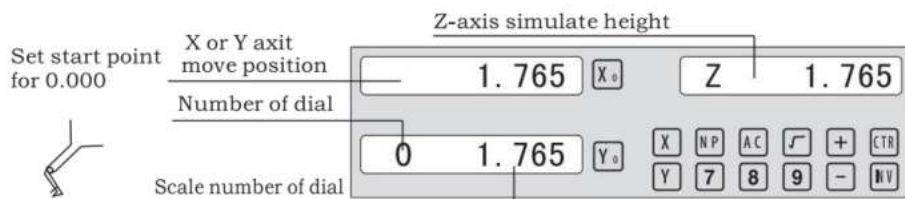

Z-axis simulate height = Number of dial x Z axis Dial + Scale number of dial

Press  to quit **oblique** function any time.

## Slope Processing



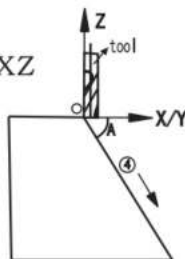

## 6.5 Slope Processing

This function can calculate the position of every processing point automatically in processing slope. Only the following parameters need to be inputted:

XZ, YZ	Set machine place YZ, or XZ
ANG	The inclination angle
Z_STEP	The slope length each time processing



**Example 1 for the Slope XZ place;**

Step 1. Select place

Press , then the message window display "XZ" to the slope Processing. Press  or  to select place to display "SEL\_XY"; Then press  to in next step;





Step 2. Input the angle of slope

The message window display "ANG", X window displays the formerly preset the angle of slope. Press   in turn.



Step 3. Input Z\_step;

The message window display "Z STEP", X window displays the formerly preset the stating position of slope. Input    in turn.



Step 4:Finishing the ALL processing . Press  to quit slope function any time.

## Chambering Processing

### 6.6 Chambering Processing

1,FLAT\_XY: machine place; 2, DIA:diameter of TOOL; 3, CENTER: center of the chambering ; 4, SIZE: size of the chambering ;

Figure as follow:

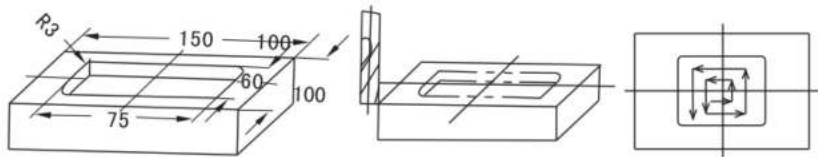

STEPS:

1. Press , then the message window display “FLAT\_XY” to the Chambering Processing.



2. Input DIA of the TOOL;





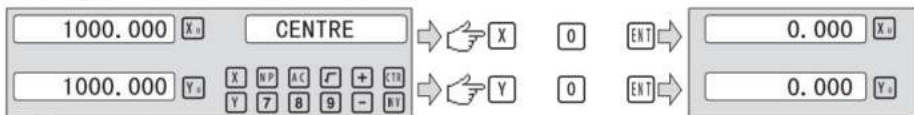

3. Input the center coordinate;

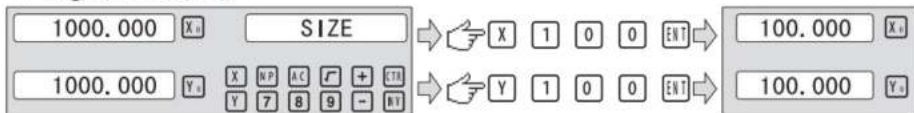

4. Input the size;



5. process Chambering;

Move the machine until the display of the axis is zero,ie, the position of the first point. Machine the first point . Display the next machining point by pressing  or  .On the completion of machining, the right window shows OVER. Press  or , the system will goto the first position for the next workpiece. Press  to quit the Chambering Function.

## The Tool Diameter Compensation Function

### 6.7 The Tool Diameter Compensation Function

Without TOOL compensation, the operator has to move the TOOL for an additional distance of the diameter of the TOOL along each side when machining the four 150 and 100 sides of a workpiece to finish machining the whole brim. The digital readouts shall automatically compensate when the TOOL compensation function is enable.

Note: the TOOL compensation is made in the direction of X and Yaxis.

Procedures:

- 1). Enter the function of compensating the diameter of the TOOL.
- 2). Select one of the (four) preset machining modes.
- 3). Input the diameter of the TOOL.
- 4). Enter machining.

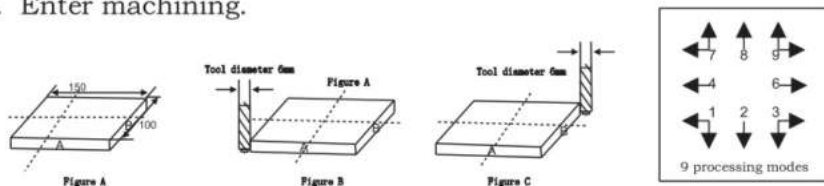

Step1: press  $\frac{Dm}{13}$  to enter the TOOL compensation Function. then the message window display “TYPE” .Press **9** .



Step 2: input the diameter of the TOOL; Press **1** **0** in turn..



Step 3: Press  $\nabla$  to the machining Mode.

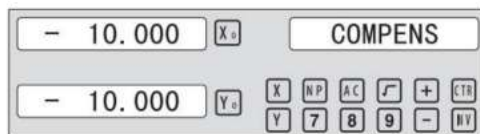

Machining of 2 side planes can be done by moving the TOOL until X-Axis is 150.000 and Y-Axis is 100.000.Press the Key  $\frac{Dm}{13}$  to quit the Function.

## The Tool Diameter Compensation Function

---

### 6.8 Digital Filter of the Grinding Machine

When machine a work-piece by grinder, the display values quickly due to the vibration of grinder. User can not see display value clearly. Grinder DRO provides display value filter function to disable the quake change of display value.

STEPS:

1. Enter display value filter function.

In normal display state, press **SFT** to simultaneously, enter display value filter function.

2. Exit display value filter function;

Press **SFT** , exit display value filter function;

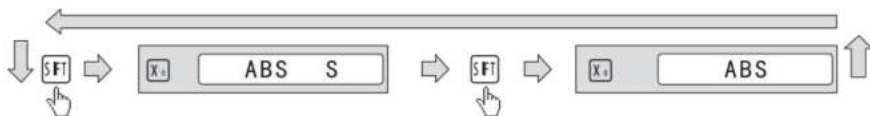

## 6. 9 La fonction

### 6.9. 1 200 ensembles de bibliothèques d'outils

Il faut toujours un OUTIL différent lors du traitement de différentes pièces. Pour le fonctionnement pratique, les affichages numériques ont pour fonction de

200 ensembles de bibliothèques d'outils.

Remarque : les 200 jeux de bibliothèques d'outils peuvent être utilisés uniquement lorsque le tour est équipé du bloc de réglage d'outils.

1. Définissez un OUTIL de référence. Après le réglage de l'outil, l'axe X et l'axe Z à zéro, l'outil met à zéro la coordonnée absolue.

2. En fonction de la taille de TOOL I et de datum TOOL, déterminez la position de l'OUTIL par rapport au zéro de la coordonnée absolue et de l'outil de référence. AS Figure 6-1.

La taille relative de l'OUTIL 2 est AS suit l'axe X 25-30=-5

, Axe Z 20-10=10.

3. Enregistrez le numéro de l'OUTIL et la taille dans l'affichage numérique.

4. Le nombre d'OUTILS peut être saisi au hasard, les lectures numériques affichera la position de l'outil à la coordonnée absolue zéro. Déplacez la jusqu'à ce que l'axe X et l'axe Z affichent tous deux zéro.

Les bibliothèques d'outils peuvent enregistrer les 200 ensembles de données d'outils.

6. Les bibliothèques d'outils doivent être utilisées dans l'état d'ouverture. Les 200 ensembles

Les bibliothèques rooi peuvent être ouvertes en appuyant continuellement  dix fois

jusqu'à ce que la fenêtre de droite clignote TL - OPEN et une marque "21" s'affiche à gauche de la fenêtre d'information de droite. La marque indique le

L'opérateur peut configurer ou réviser les 200 ensembles de bibliothèques d'outils en continu

en appuyant sur la  dix fois entraîneront la destruction des 200 ensembles de bibliothèques d'outils touche fermée et la fenêtre droite clignote TL - CLOSE et la marque

disparaître. Lorsque la marque « 21 » disparaît, les 200 ensembles de bibliothèques d'outils peuvent ne pas être révisés.

Les opérations pour les données TOOL et l'appel de TOOL sont présentées comme suit :

étape 1 : Dans l'état ABS, saisissez les données des 200 ensembles de bibliothèques TOOL.

ouvrir les 200 ensembles TOOL Libs en appuyant continuellement sur la touche

 dix fois. A. Mark "" apparaîtra dans la fenêtre gauche de la fenêtre droite

fenêtre d'information.

## Lathe Function

étape 2 : appuyez sur **TOOL** pour accéder à l'état d'entrée. Entrez les données roci 1 :

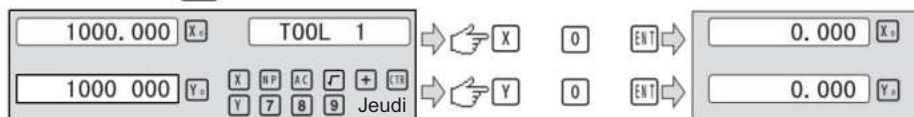

étape 3 : Saisie des données de l'OUTIL 2 :

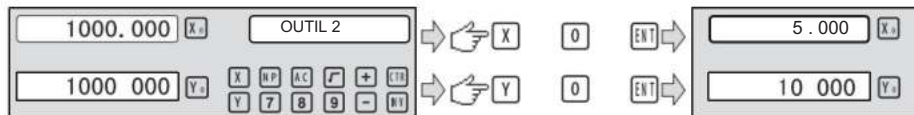

étape 4 : appuyez sur pour continuer à saisir les données de l'outil suivant. EN APPUYANT

**numéro et la clé** l'opérateur peut directement saisir le spécial

données d'outils. appuyez sur **TOOL** touche

Une fois les bibliothèques d'outils configurées, utilisez les bibliothèques d'outils conformément aux  
après les opérations suivantes, montez d'abord le deuxième outil :

étape 5 : Pour accéder à l'état d'utilisation en appuyant sur **CALL** .Puis appuyez sur **2** EN T :



étape 6 : appuyez sur **▲** ou **▼** · sélectionnez le rôle de base. Appuyez ensuite sur **1** ENT :



étape 7 : appuyez sur **CALL** pour quitter la fonction ;

Note:

lorsque l'outil de base est utilisé , l'axe ne peut pas être mis à zéro dans l'état ABS ·  
quand les autres sont utilisés , l'axe ne peut être mis à zéro que dans l'état INC ·

### 6. 9. 2 Fonction conique

Pour le tournage de la pièce avec un cône, le cône de la pièce peut  
être mesuré dans le traitement;

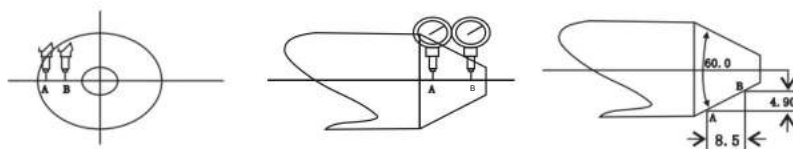

## Lathe Function

### Operations :

Figure AS, surface de contact A de la pièce avec lectures de levier et réinitialise le point de lecture du levier à zéro ·

étape 1 : appuyez sur  puis la fenêtre de message affiche UMEASU" à l' traitement du papier · Déplacez le levier de lecture vers la surface B jusqu'à ce que les lectures du levier indiquent que le AS suit ;

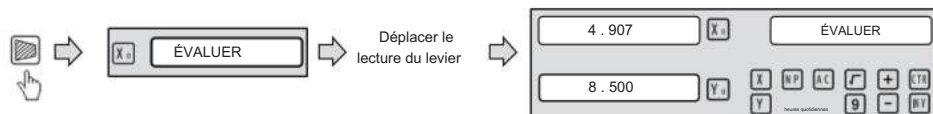

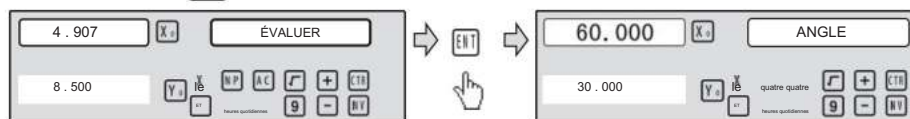

étape 2 : appuyez sur  T pour calculer.



étape 3 : appuyez sur  pour quitter la fonction ;

### 6. 9. 3 Fonction R/D

Pour les tours 2 x et les tours 3 axes, appuyez sur  , Le mode d'affichage l'axe des x est commuté entre le rayon et le diamètre. lorsque l'axe des x pour affichage du diamètre, une fenêtre d'information  " apparaîtra à gauche de la droite de marque u, mais lorsque l'axe X pour l'affichage d'un compteur ia , la marque " " disparaît · seul l'axe x a la fonction du diamètre/rayon transformation.

### 6. 9. 4 Fonction Y + Z (applicable uniquement à : 3 axes La the)

Pour 3 axes La le, le compteur de l'axe y et le compteur de l'axe z

Peut être ajouté pour être affiché sur l'axe Z en appuyant sur la touche  , puis appuyez sur la touche CAn pour annuler la fonction y + Z ·

6.10 EDM (fonction de personnalisation spéciale, si vous devez acheter, veuillez contacter le revendeur pour personnaliser)

1 Description : Cette fonction est utilisée pour l'usinage spécial de Usinage par électroérosion (EDM) . lorsque la valeur cible définie pour l'EDM L'axe Z est égal à la valeur actuelle, l'affichage numérique affichera la valeur signal de commutation pour contrôler l'EDM afin d'arrêter l'usinage en profondeur.

Le réglage de la direction de l'axe Z de l'affichage numérique est illustré dans la figure 1. , ie Plus la profondeur est grande, plus la valeur des coordonnées de l'axe Z est grande affiche · depuis le début de l'usinage, la profondeur va progressivement s'approfondir et l'axe Z.

Selon la direction de l'axe Z définie, la direction d'usinage est divisé en usinage positif et négatif · lorsque l'électrode descend et l'usinage s'effectue de haut en bas, le numérique la valeur de lecture augmentera, ce qui est appelé usinage positif (positif). Le réglage de cette direction est le réglage normal·

lorsque l'électrode ASC se termine et que l'usinage est effectué de bas en haut, la valeur de lecture numérique diminuera · Le la direction d'usinage est la direction négative (négative), qui est également appelée usinage négatif (représenté par la Fig. 1)

L'affichage numérique dispose également d'autres fonctions , tel que négatif hauteur anti-incendie. La fonction de hauteur anti-incendie négative est une sorte de dispositif de protection de sécurité de suivi de position intelligent. Dans le processus de l'usinage, la surface de l'électrode va générer le carbone phénomène d'accumulation. En raison de l'usinage de longue durée ou diurne sans tendre, lors de la génération de l'accumulation de carbone et personne ne fait le nettoyage, l'électrode augmentera lentement le long de la direction négative · une fois que l'électrode dépasse le niveau de liquide, elle prennent souvent feu et provoquent des pertes. Cette fonction est simplement configurée pour viser à ce problème. lors du réglage de la hauteur coupe-feu négative, et le la hauteur accrue de l'électrode dépasse la hauteur entre elle et la profondeur de la surface usinée (c'est-à-dire hauteur ignifuge négative), le numérique l'affichage de lecture clignotera pendant WQring ; en même temps, la sortie le signal éteindra automatiquement l'EDM pour éliminer le risque d'incendie ·

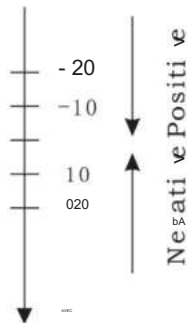

Figure 1

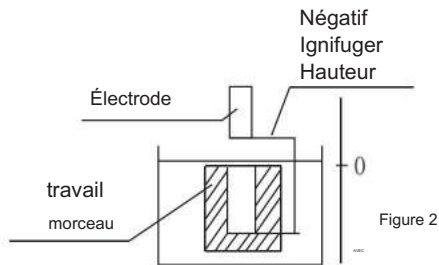



Figure 2

## 2. procédure :

voir l'exemple suivant pour l'usinage détaillé

- 1) Avant l'usinage, définissez d'abord chaque paramètre de PROFONDEUR (profondeur d'usinage); ERRHIGH( hauteur coupe-feu négative), usinage direction (POSITIF / NÉGATIF) ; mode de sortie (AUTO/STOP) et Mode de sortie relais EDM · 2)

Déplacez l'électrode de l'axe principal de l'axe Z pour la mettre en contact avec le référence de la pièce · remettre l'axe A à zéro ou définir la valeur ·

- 3) Entrez dans l'usinage EDM en appuyant sur la touche .

4) L'axe X affichera la valeur cible de la profondeur d'usinage. L'axe Y affichera la valeur d'affichage doit être la profondeur. (La valeur sur l'axe Y est la valeur que la pièce a été usinée en profondeur) L'axe Z sera affiche la valeur en temps réel de l'auto-positionnement. (La valeur sur l'axe Z est la valeur de position de l'électrode de l'axe principal de l'axe z.)

5) démarrer l'usinage, la valeur d'affichage de l'axe Z se rapproche progressivement de la valeur cible, la valeur d'affichage de l'axe Y se rapproche également progressivement de la valeur cible. Si à ce moment, l'électrode est montée et descendue à plusieurs reprises, la valeur d'affichage de l'axe Z changera par la suite, mais l'affichage de l'axe Y la valeur ne changera pas, ce qui affichera toujours la profondeur usinée **value.**

6) lorsque la valeur d'affichage de l'axe Z est égale à la valeur cible définie, le l'interrupteur de position sera désactivé, l'EDM arrêtera l'usinage, Selon le réglage de l'opérateur · Il existe deux types de modes de sortie :

## a) Automatic Mode:

it will automatically exit from EDM machining status and recover to the original state before machining;

## b) Stop Mode:

It will always stay at the machining interface after finishing machining, and you should press **EDM** to exit and back to the original state.

**Operation steps:**

**The DEPTH (machining Depth), ERRHIGH (Negative fireproof height), exit Mode, EDM Relay Output Mode and machining direction should be set.**

**STEPS:**

1. Press **EDM** to enter the EDM Function. Press **▲** to input parameters; Press **▼** to enter EDM machining state.

2. Input DEPTH ( machining depth). Press the key **▲** to set the next parameter.



3. input ERRHIGH ( Negative Fireproof Height ) (undefine) .Press the key **▲** to set the next parameter.



4. Set machining direction(Positive or Negative). Press **1** to select Positive direction. Press **0** to select Negative direction. Press the key **▲** to set the next parameter.



## EDM

5. Set exit Mode (AUTO Mode or STOP Mode) Press **0** to select AUTO Mode; Press **1** to select STOP Mode ; Press the key **▲** to set the next parameter.

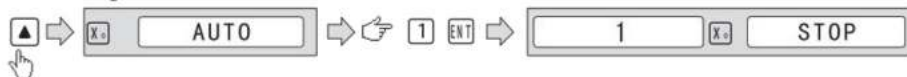

6. Set the Output Mode (Mode 0 or Mode 1); ( undefine ). Press **0** to select Mode 0; Press **1** to select Mode 1.

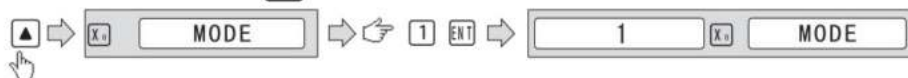

7. Continuously press **▼** to return EDM for machining. press **EDM** to quit the function;

### Example 1: positive direction machining ;

Machining is shown as the model chamber as follows

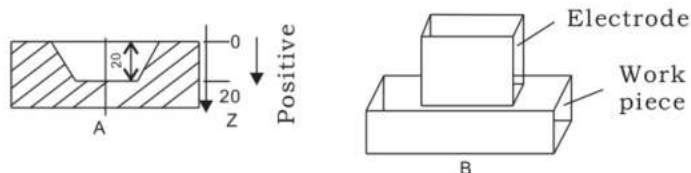

#### STEPS:

1、Touch one side of the workpiece with the TOOL, then press **Z0** , zero the Z axis.



2、 Press **EDM** , Setting DEPTH for 20.000; press **▼** to EDM for machining;



3、 Starting machining.

## EDM

Machining depth target value	<input type="text" value="20.000"/>	X <sub>0</sub>	<input type="button" value="EDM RUN"/>
Value has been to be depth	<input type="text" value="0.000"/>	Y <sub>0</sub>	
Self-position real time value	<input type="text" value="0.000"/>	Z <sub>0</sub>	

**Example 2: Negative direction machining**

Machining is shown as the model chamber as follows

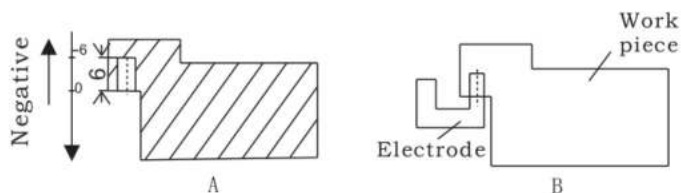

- 1、Touch one side of the workpiece with the TOOL, then press  , zero the Z axis.

<input type="text" value="1000.000"/>	Z <sub>0</sub>	→	←	Z <sub>0</sub>	→	<input type="text" value="0.000"/>	Z <sub>0</sub>
---------------------------------------	----------------	---	---	----------------	---	------------------------------------	----------------

- 2、Press  , Setting DEPTH for -20.000; press  to EDM for machining;

<input type="button" value="EDM"/>	→	X <sub>0</sub>	<input type="text" value="DEPTH"/>	→	←	<input type="text" value="± 2 0"/>	ENT	→	<input type="text" value="-20.000"/>	X <sub>0</sub>	<input type="text" value="DEPTH"/>
------------------------------------	---	----------------	------------------------------------	---	---	------------------------------------	-----	---	--------------------------------------	----------------	------------------------------------

- 3、Starting machining.

Machining depth target value	<input type="text" value="20.000"/>	X <sub>0</sub>	<input type="button" value="EDM RUN"/>
Value has been to be depth	<input type="text" value="0.000"/>	Y <sub>0</sub>	
Self-position real time value	<input type="text" value="0.000"/>	Z <sub>0</sub>	

**Example 3: PCD Function for EDM**

PCD Function can access the EDM Function . The operator enters PCD Function to input parameters for PCD and enter PCD machining state. At every position for machining, press the key  to access the EDM Function .



lors de l'entrée dans la fonction EDM, l'opérateur peut saisir les paramètres pour EDM ·

La procédure de fonctionnement est la suivante :

1) définir les paramètres PCD (le réglage est le même que le réglage commun de PCD)

Après avoir saisi tous les paramètres et entré l'état d'usinage PCD · Le la position du premier trou sera affichée.

2) appuyez sur  pour entrer le paramètre de fonction EDM (la méthode de réglage est sur le même que le réglage commun du paramètre EDM) ; après avoir saisi tout

paramètres, appuyez en continu lorsque l'usinage  pour entrer dans l'état d'usinage EDM. pour est terminé, appuyez sur entrer dans l'état d'usinage  quitter la fonction EDM et PCD ·

3 ) Dans l'état d'usinage PCD, appuyez sur  pour la position du trou suivant, OVE la machine à la valeur d'affichage 0 , alors pr css  pour accéder

Fonction EDM à nouveau · 4)

Répétez l'étape 2 et l'étape 3 pour les points d'usinage suivants.

## Calculator

### 7 calculatrice

La calculatrice ne fournit pas seulement des calculs mathématiques normaux comme +, -,  $\times$ , /, il fournit également des calculs trigonométriques tels que

PECHÉ, Arc NAS, COS, Arc COS, TANNÉ, Arc TAN SQRT etc.

Les opérations sont les mêmes que celles des calculatrices commerciales, faciles à utiliser.  
Fonction d'entrée et de sortie de la calculatrice

en état d'affichage normal : appuyez sur R pour accéder à la fonction calculatrice.

dans l'état d'affichage de la calculatrice : appuyez sur R pour quitter la fonction calculatrice.

Transfert de l'échelle Résultats pour les zx sélectionnés.

Une fois le calcul terminé, si la calculatrice affiche le mode défini sur mode 1, l'utilisateur peut :

appuyez sur  $X_0$  pour transférer le résultat calculé sur l'axe x ; puis l'axe x sur la fenêtre pour afficher cette valeur ;

presse sur  $Y_0$  pour transférer le résultat calculé à l'axe du jouet ; puis ils la fenêtre affichera cette valeur ;

appuyez sur  $Z_0$  pour transférer le résultat calculé vers l'axe z ; puis le z sur la fenêtre pour afficher cette valeur ;

Transfert de la valeur d'affichage actuelle dans la fenêtre vers la calculatrice.

si la calculatrice affiche le mode défini pour le mode 1, l'utilisateur peut :

presse sur  $X$  pour transférer la valeur d'affichage dans la fenêtre x vers la calculatrice ;

presse sur  $Y$  pour transférer la valeur d'affichage dans la fenêtre Y pour calculer r ;

presse sur  $Z$  pour transférer la valeur d'affichage dans la fenêtre z vers la calculatrice ;

## Appendix

## 8 Appendix

## 1. Troubleshooting:

The following are the preliminary solvents for troubleshooting.

If there is still trouble, Please contact out company or agents for help.

Troubles	Possible reasons	Solvents
No display	<ol style="list-style-type: none"> <li>1. Power isn't connected</li> <li>2. Power switch is off.</li> <li>3. The range of power voltage is not right.</li> <li>4. The inner power of Linear Scale is short.</li> </ol>	<ol style="list-style-type: none"> <li>1. Check power wire and connect the power</li> <li>2. Turn on the power switch.</li> <li>3. The range of voltage is in 80--260V</li> <li>4. Unplug the connector of linear scale</li> </ol>
One axis is not counting	<ol style="list-style-type: none"> <li>1. Replace the linear scale of the other axis.</li> <li>2. DRO is in special function</li> </ol>	<ol style="list-style-type: none"> <li>1. If count is normal, the linear scale has trouble; If abnormal, the DRO readouts has trouble.</li> <li>2. Quit the special function.</li> </ol>
Linear scale is not counting	<ol style="list-style-type: none"> <li>1. Reading head is bad for using range exceeds.</li> <li>2. Aluminum chips is in reading head of linear scale.</li> <li>3. The span between the reading head and metal part of linear scale is large.</li> <li>4. The metal parts of linear scale is damage.</li> </ol>	<ol style="list-style-type: none"> <li>1. Repair the linear scale</li> <li>2. Repair the linear scale</li> <li>3. Repair the linear scale</li> <li>4. Repair the linear scale</li> </ol>
Counting is error	<ol style="list-style-type: none"> <li>1. Shell is poor grounding.</li> <li>2. Low precision of machine.</li> <li>3. Speed of machine is too rapid.</li> <li>4. Precision of linear scale is low.</li> <li>5. The resolution of DRO readouts and the linear scale is not match.</li> <li>6. The unit (mm/inch) is not match.</li> <li>7. Setting the linear compensating is not arrest.</li> <li>8. Reading head of the linear scale is damaged.</li> </ol>	<ol style="list-style-type: none"> <li>1. Shell is good grounding.</li> <li>2. Repair the machine.</li> <li>3. Reduce the speed of machine.</li> <li>4. Mount the linear scale again.</li> <li>5. Set the resolution of the DRO again.</li> <li>6. Cover the unit of display mm/inch.</li> <li>7. Reset the linear compensation.</li> <li>8. Repair the linear scale.</li> </ol>
The counting of the linear scale is not accurate	<ol style="list-style-type: none"> <li>1. The mounting of linear scale does not demand the requirement, and the prcision is not adequate.</li> <li>2. The screw is loosen.</li> <li>3. Precision of machine is low.</li> <li>4. The resolution of digital readouts and the linear scale is not match.</li> </ol>	<ol style="list-style-type: none"> <li>1. Mount the linear scale again and level it.</li> <li>2. Lock all fixing screws.</li> <li>3. Repair the machine.</li> <li>4. Reset the resolution of digital readouts.</li> </ol>
Sometimes the linear scale is not counting	<ol style="list-style-type: none"> <li>1. The small car and steel ball is separated.</li> <li>2. The glass of reading head is wearied.</li> <li>3. The glass of reading head of the linear scale has dirt.</li> <li>4. The elasticity of the steel wire is not adequate.</li> </ol>	<ol style="list-style-type: none"> <li>1. Repair the linear scale.</li> <li>2. Repair the linear scale.</li> <li>3. Repair the linear scale.</li> <li>4. Repair the linear scale.</li> </ol>

## Appendix

### 2. Specifications of Digital Readout.

- 1) Supply Voltage range: AC 85 V ~ 230 V; 50 ~ 60 Hz
- 2) Power consumption: 15VA
- 3) Operating temperature: 0°C-- 50°C
- 4) Storage temperature: - 30°C-- 70°C
- 5) Relative humidity: < 90 % ( 25 )
- 6) Max Coordinate number: 3
- 7) Readout allowable input signal: TTL square wave
- 8) Allowable input signal frequency: < 5 M Hz
- 9) Max resolution of digital display length: 0.01  $\mu$ m
- 10) Max resolution of digital display angle: 0.0001 / PULSE

### 3. Instructions

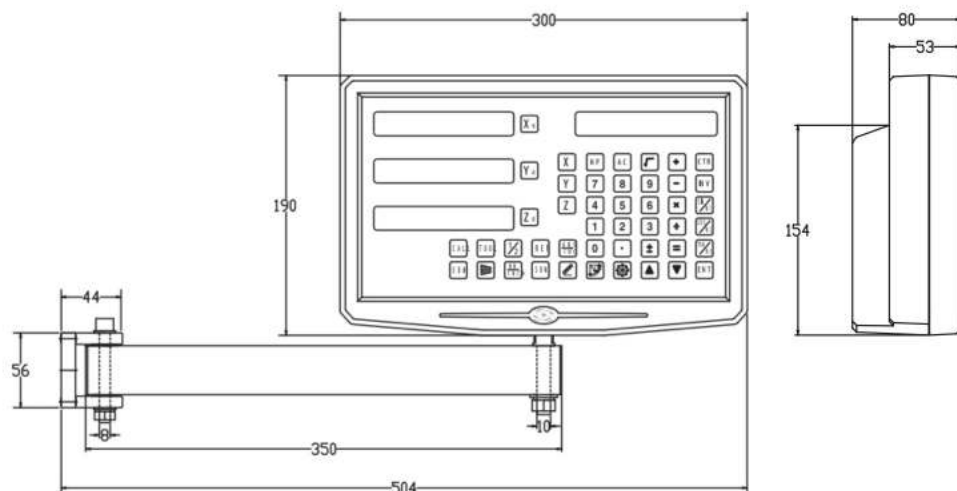

## 4. Examples of character output at the data interface

## 1、 X,Y,Z Axis

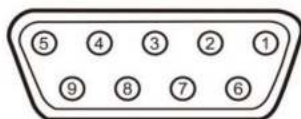

Pin	TTL (Standard)
1	
2	0V
3	
4	
5	
6	A+
7	5V
8	B+
9	R+

Pin	TTL (Standard)
1	5V
2	0V
3	A+
4	B+
5	R+
6	
7	
8	
9	

For your convenience,  
If you buy a digital readout,

The wiring definition of your linear scale must be the same as the 2 definitions in the above diagram to be universal!

# Installation Instructions

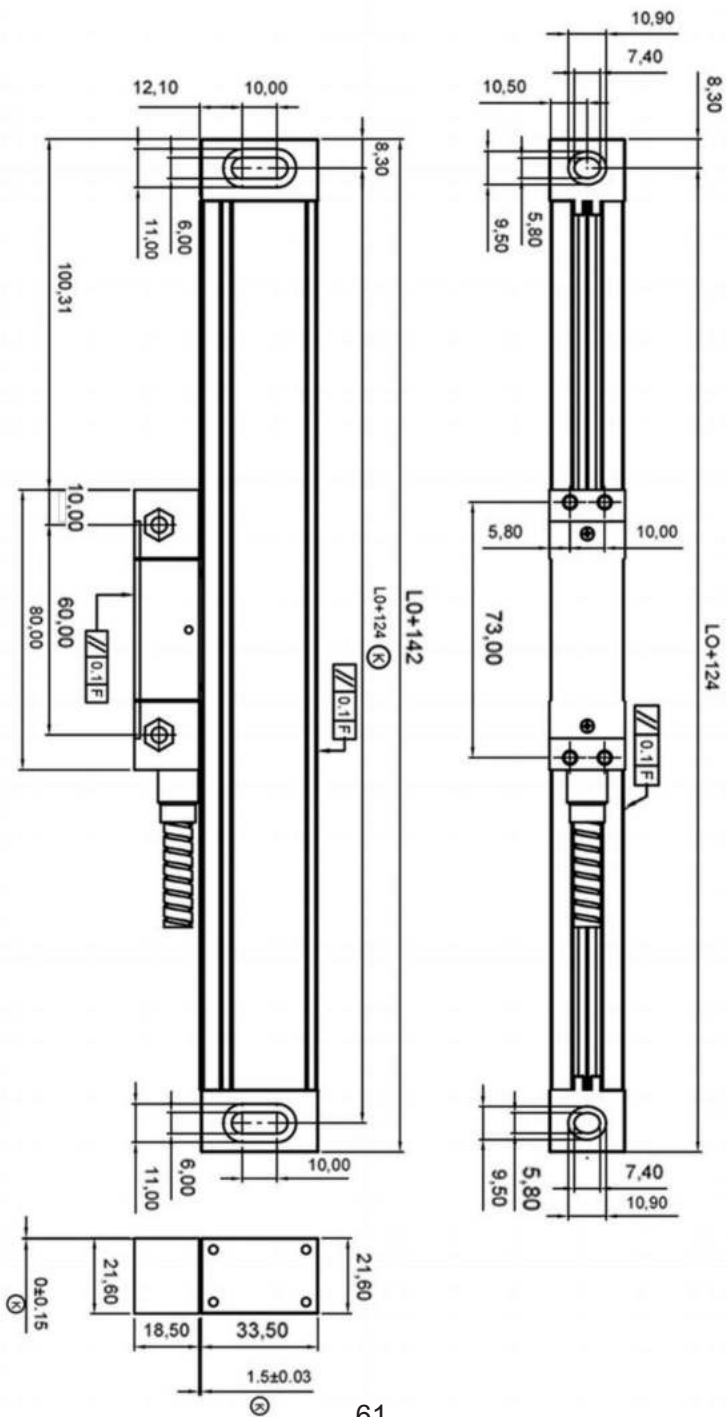

## TTL signal Output:

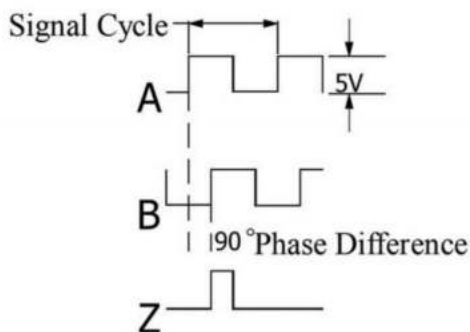

## EIA-422-A signal Output:

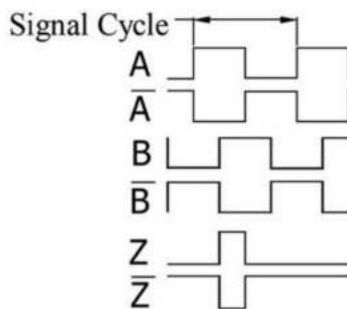

## 1. TECHNICAL PARAMETER

1.1 SCALING DISTANCE: 0.02 MM (50LINES /MM)

1.2 RESOLUTION: 5 $\mu$ M、1 $\mu$ M、0.5 $\mu$ M1.3 PRECISION:  $\pm 3\mu$ M、 $\pm 5\mu$ M、 $\pm 15\mu$ M/M (20 $\pm$ 0.1°C)

1.4 MEASURING RANGE: 30~3000MM

1.5 MOVING SPEED: HIGH-SPEED ENCODER 120 M/MIN (TO BE CUSTOMIZED)

ORDINARY ENCODER 60M/MIN

1.6 POWER SUPPLY: +5V $\pm$ 5%、80MA

1.7 CABLE LENGTH: STANDARD 3M (SPECIAL LENGTH AVAILABLE ACCORDING TO THE USER'S NEEDS)☒

1.8 WORKING TEMPERATURE: 0~45°C

1.9 PIN DESCRIPTION:

1) APPLICABLE TO: 9 PIN SOCKET EIA-422-A SIGNAL OUTPUT.

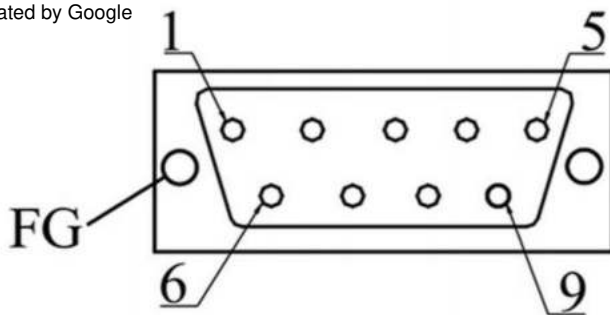

1) Applicable to: 9 pin socket EIA-422-A signal Output.

Pin Position	1	2	3	4	5	6	7	8	9
Signal	$\bar{A}$	$OV$	$\bar{B}$	Empty	$\bar{Z}$	$A$	+5V	$B$	$Z$
Color	Green Black	Black	Orange black	FG	White black	Green	Red	White	Orange

FG: Shield connected to metal casing.

1) Applicable to: 9 pin socket TTL signal Output.

Pin Position	1	2	3	4	5	6	7	8	9
Signal		$OV$		Empty		$A$	+5V	$B$	$Z$
Color		Black		FG		Green	Red	Orange	White

FG: Shield connected to metal casing.

# Échelle linéaire

## Dessins d'installation

## Méthode d'installation :

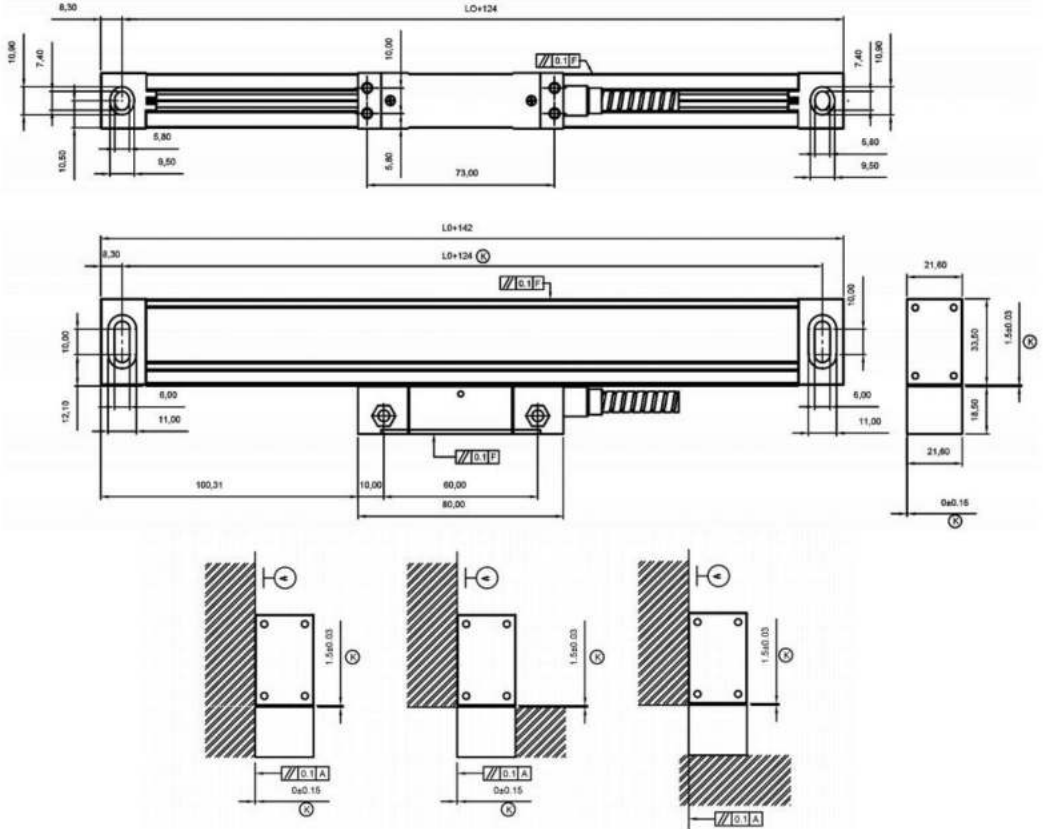

Taille standard : (Unité : mm)

Modèle	IL	L1	L2	Modèle	L0	L1	L2
YE-50	50	174	190	YE-550 550		674	690
YE-100	100	224	240	YE-600	600	724	740
YE-150	150	274	290	YE-650 650		774	790
YE-200 200		324	340	YE-700 700		824	840
YE-250 250		374	390	YE-750	750	874	890
YE-300 300		424	440	YE-800	800	924	940
YE-350 350		474	490	YE-850 850		974	990
YE-400 400		524	540	YE-900	900	1024	1040
YE-450 450		574	590	YE-950 950		1074	1090
YE-500 500		624	640	YE-1000 1000		1124	1140

L0 : Longueur de mesure effective du codeur linéaire ; L1 : Longueur du codeur linéaire trous de montage ; L2 : longueur totale du codeur linéaire

## Entretien:

1. La course effective du codeur linéaire doit être plus longue que la course maximale déplacement de la machine-outil. Si la longueur n'est pas suffisante, remplacez le codeur linéaire par une course plus grande ou ajoutez un bloc de fin de course sur les machines. La position finale de la tête de lecture par rapport à l'extrémité du corps du codeur linéaire ne doit pas être inférieure à 10 mm (voir le schéma suivant).

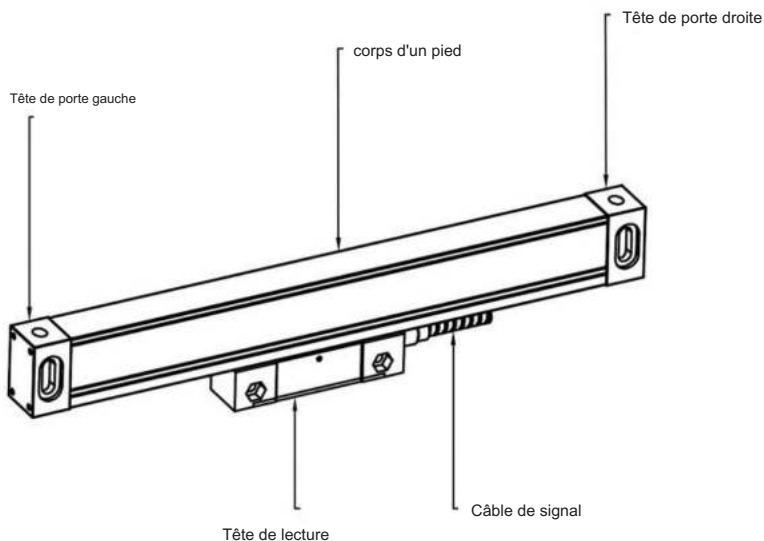

2. Pour toute surface non usinée, une cale doit être placée à l'arrière du codeur linéaire ou une cale d'installation fabriquée par l'utilisateur doit être utilisée pour assurer la stabilité et la fiabilité de la connexion entre la règle de réseau et la surface de montage.
3. Lorsque vous utilisez un comparateur à cadran ou un instrument similaire pour étalonner le parallélisme du codeur linéaire, l'angle de la tête latérale doit être compris entre  $\pm 30$  degrés, et plus l'angle est petit, mieux c'est.

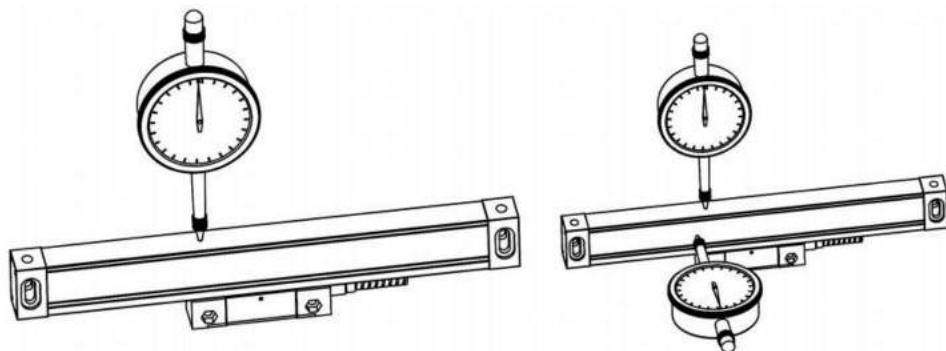

4. La position d'installation du codeur linéaire doit éviter tout impact direct du fer limailles, huile, eau et poussière (comme indiqué sur la figure ci-dessous). La longueur d'installation de la plaque en L doit être aussi courte que possible dans les circonstances possibles, et la situation de force de la surface de montage doit être prise en considération.

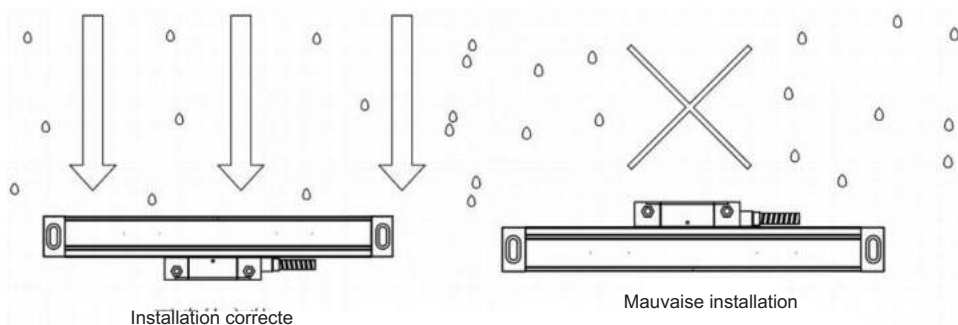

5. Il doit y avoir un espace de 0,5 mm ou plus entre le cache-poussière et la règle corps et éviter tout contact entre le cache-poussière et le corps de la règle lorsque déplacer la tête de lecture (comme ci-dessous).
6. Profondeur du filetage de la vis d'installation, doit avoir au moins 6 dents de profondeur de verrouillage ; force la plus grande partie, comme le support de la plaque fixe de l'étagère du compteur d'affichage numérique, doit avoir 8 dents de profondeur de verrouillage ; série YE d'échelle, la profondeur du filetage doit être la même que la profondeur de verrouillage. Tels que le support de l'étagère du compteur d'affichage numérique fixe plaque, doit avoir une profondeur de verrouillage supérieure à 8 dents ; échelle de la série YE avec vis M4 surface de montage installée taraudage après ébavurage de surface, peinture, élimination des taches. (La figure suivante)

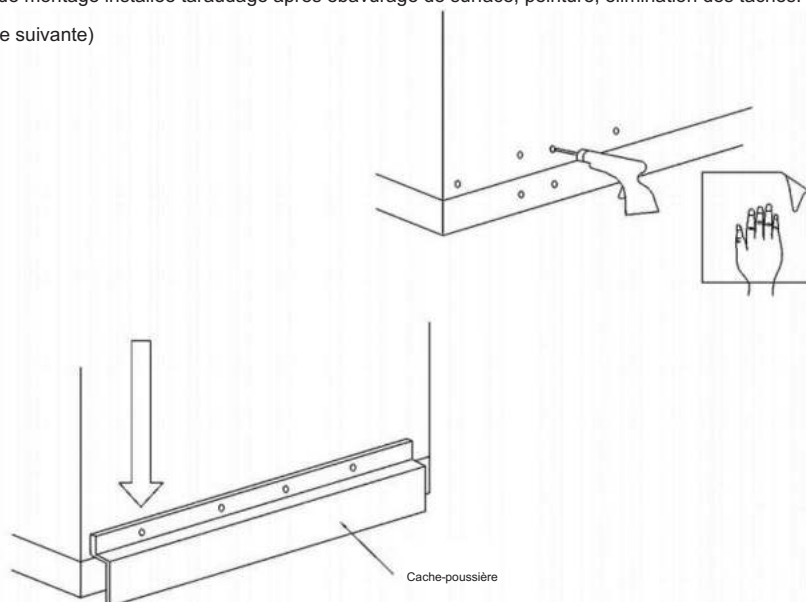

7. La fixation de la ligne de signalisation doit tenir compte de toutes les distances de déplacement pertinentes.  
Position de fixation placée autant que possible au centre même de la course, et la ligne de signal en excès est fixée avec un lien métallique.
8. Le réglage de la hauteur de l'échelle doit être la longueur du centre de l'échelle pour prendre les deux côtés du point de symétrie. Pour ajuster le point de référence, quelle que soit l'échelle, quelle que soit la direction du niveau scolaire ou de la hauteur, la plage de réglage : pour le corps de l'échelle, à une distance ne dépassant pas 20 mm de chaque extrémité de la tête de lecture doit prévaloir. Pour la tête de lecture, entre les deux surfaces de référence quadrilatérales (figure suivante)

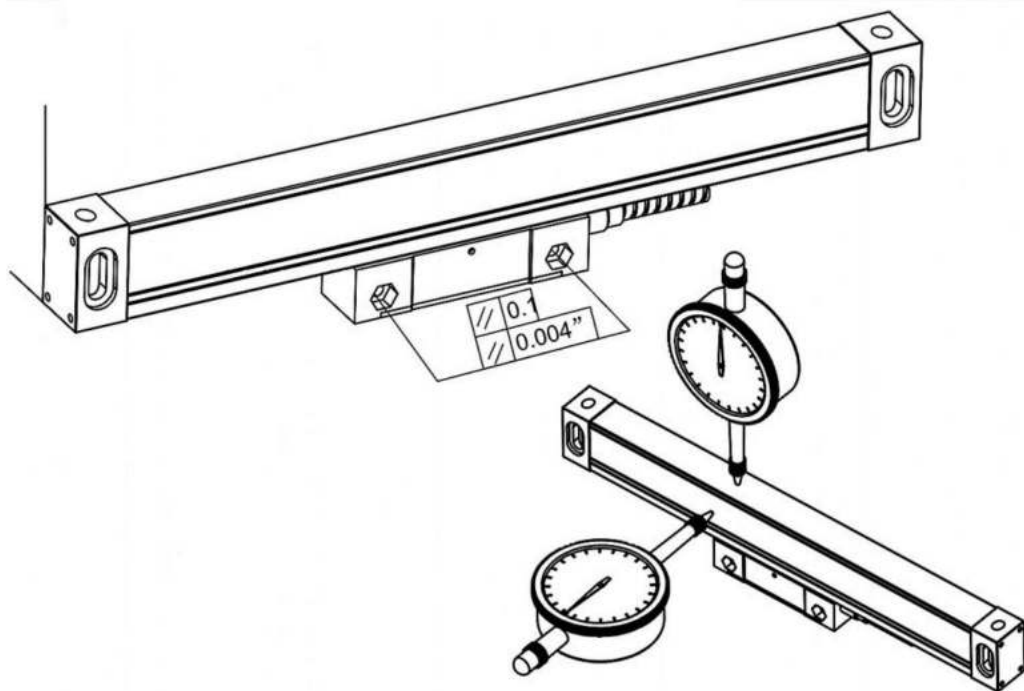

9. Le rayon de courbure de la ligne de signal de la balance est supérieur à 60 mm.

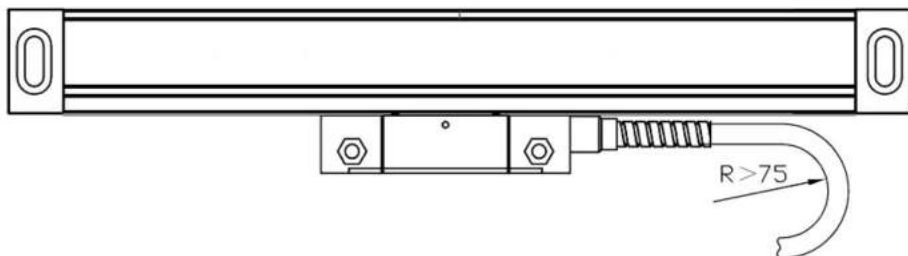

## 10. Norme d'installation de la balance

(1) Norme de surface de base d'installation (Figure 4.8abc trois méthodes d'installation)

1. La surface d'installation du corps de la règle est parallèle à la surface d'installation de la tête de lecture et le parallélisme entre les surfaces d'installation est  $< 0,1 \text{ mm}$

2. La surface d'installation du corps de la règle est perpendiculaire à l'installation

surface de la tête de lecture et la perpendicularité entre les surfaces d'installation est  $< 0,1 \text{ mm}$

2) Normes d'installation du corps de règle (Figure 4.9, Figure 4.10)

1. Sens de hauteur par rapport au parallélisme du guide de la machine  $< 0,1 \text{ mm}$ , maximum ne dépassant pas  $0,15 \text{ mm}$  En termes de point de symétrie, plus il est petit, mieux c'est.

3) Norme d'installation de la tête de lecture

1. L'espace entre la tête de lecture et la direction de la hauteur du corps de la règle est de  $0,8 \text{ mm}$  à  $1,6 \text{ mm}$  après l'installation, puis retirez le bloc de tampon (Figure 4.11)

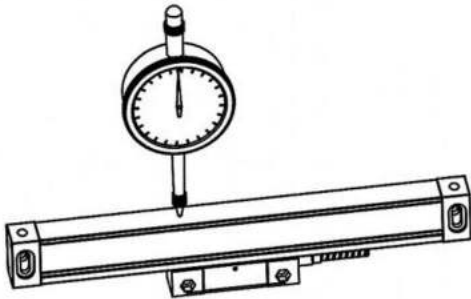

4.9

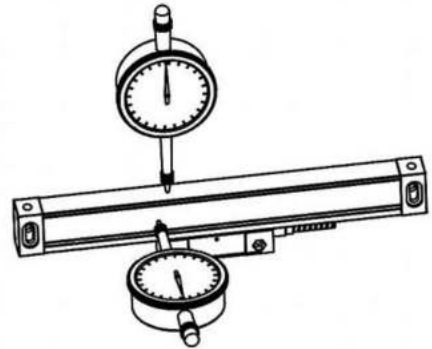

4.10

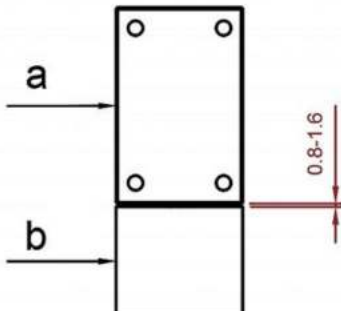

2. Tête de lecture côté A et corps de la règle côté B.  
Désalignement dans le sens horizontal.

$0,25 \pm 0,15 \text{ mm}$

3. Parallélisme de la tête de lecture par rapport à

machine-outil  $< 0,10 \text{ mm}$ , le maximum ne peut pas dépasser  $0,30 \text{ mm}$

## Paramètre:

<b>Modèle</b>	<b>SNS-3V-YE102024</b>	<b>SNS-3V-YE161838</b>
<b>Rated voltage:</b>	CA 85-230 V 50 Hz/60 Hz	
<b>Resolution</b>	5 $\mu$ m	
<b>Number of axes</b>	3	
<b>Range</b>	10 inches 20 inches 24 inches	16 inches 18 inches 38 inches

## Accessoires standards :

<b>Accessories for digital display meters:</b>	<b>Accessories for grating ruler:</b>
<ol style="list-style-type: none"> <li>1. Support rod * 1</li> <li>2. Knife holder plate * 1</li> <li>3. Transparent watch case * 1</li> <li>4. Power cord * 1</li> <li>5. Watch holder * 1</li> <li>6. Butterfly piece * 2</li> <li>7. M8 * 70 screw * 1</li> <li>8. M10 * 55 screw * 1</li> <li>9. Nut M10 * 1</li> <li>10. Nut M8 * 1</li> <li>11. Nut M5 * 1</li> <li>12. Internal hexagonal screw M5 * 20 * 2</li> <li>13. Internal hexagonal screw M5 * 25 * 1</li> <li>14. M4 * hex socket screw * 4</li> <li>15. M5 * 10 machine meter screws * 2</li> <li>16. Washer <math>\phi</math> 10 * 1</li> <li>17. Washer <math>\phi</math> 8 * 1</li> <li>18. Washer <math>\phi</math> 5 * 1</li> <li>19. Rubber washer 20 * 10 * 1 * 1</li> <li>20. Rubber washer 20 * 10 * 0.5 * 1</li> <li>21. Spring washer <math>\phi</math> 10 * 1</li> <li>22. Spring washer <math>\phi</math> 8 * 1</li> <li>23. Spring washer <math>\phi</math> 5 * 1</li> </ol>	<ol style="list-style-type: none"> <li>1. Ruler cover * 3</li> <li>2. L mounting plate * 4</li> <li>3. Plug * 6</li> <li>4. Screw pack * 3 bags</li> </ol> <p>Each bag contains:</p> <p>Internal hexagonal screw M4 * 30 * 4;  Internal hexagonal screw M4 * 12 * 2;  Internal hexagonal screw M4 * 8 * 4;  U-shaped gasket T=0.2mm * 2;  Washer <math>\phi</math> 6 * 2;  Washer <math>\phi</math> 5 * 2;  Washer <math>\phi</math> 4 * 6;  Line card * 2</p>

Cet appareil est conforme à la partie 15 des règles de la FCC. Son fonctionnement est soumis aux deux conditions suivantes : (1) cet appareil ne doit pas provoquer d'interférences nuisibles et (2) il doit accepter toute interférence reçue, y compris les interférences pouvant provoquer un fonctionnement indésirable.

Fabricant : Shanghaimuxinmuyeyouxiangongsi

Adresse : Shuangchenglu 803nong11hao1602A-1609shi, baoshanqu, Shanghai 200000  
CN.

Importé en Australie : SIHAO PTY LTD, 1 ROKEVA STREET, ASTWOOD NSW  
2122 Australie

Importé aux États-Unis : Sanven Technology Ltd., Suite 250, 9166 Anaheim Place, Rancho  
Cucamonga, CA 91730



E-CrossStu GmbH

Mainzer Landstr.69, 60329 Francfort-sur-le-Main.



YH CONSULTING LIMITÉE.

C/O YH Consulting Limited Bureau 147, Centurion House,  
Route de Londres, Staines-upon-Thames, Surrey, TW18 4AX

**VEVOR**®  
TOUGH TOOLS, HALF PRICE

Assistance technique et certificat de garantie électronique  
[www.vevor.com/support](http://www.vevor.com/support)

# VEVOR<sup>®</sup>

## TOUGH TOOLS, HALF PRICE

Technischer Support und E-Garantie-Zertifikat

[www.vevor.com/support](http://www.vevor.com/support)

## DRO-DISPLAY-BENUTZERHANDBUCH

MODELL: SNS-3V-YE102024 IST NS-3V-YE161838

Wir sind weiterhin bestrebt, Ihnen Werkzeuge zu wettbewerbsfähigen Preisen anzubieten. "die Hälfte retten", "Halber Preis" oder andere ähnliche Ausdrücke, die wir verwenden, stellen nur eine Schätzung der Einsparungen, die Sie durch den Kauf bestimmter Werkzeuge bei uns im Vergleich zu den großen erzielten könnten Top-Marken und bedeutet nicht notwendigerweise, alle Kategorien von Werkzeugen von uns angeboten abzudecken. Sie

Wir möchten Sie bitten, bei der Bestellung sorgfältig zu prüfen, ob Sie tatsächlich sparen Sie die Hälfte im Vergleich zu den großen Top-Marken.

**VEVOR**<sup>®</sup>  
TOUGH TOOLS, HALF PRICE

DRO-ANZEIGE

MODELL: SNS-3V-YE102024 SNS-3V-YE161838



Brauchen Sie Hilfe? Kontaktieren Sie uns!

Haben Sie Fragen zu unseren Produkten? Benötigen Sie technische Unterstützung?  
Kontakt:

Technischer Support und E-Garantie-zertifikat  
[www.vevor.com/support](http://www.vevor.com/support)

Dies ist die Originalanleitung. Bitte lesen Sie alle Anweisungen im Handbuch.  
sorgfältig durch. VEVOR behält sich eine klare Auslegung unserer Bedienungsanleitung  
vor. Das Erscheinungsbild des Produkts unterliegt den  
Produkt, das Sie erhalten haben. Bitte verzeihen Sie uns, dass wir Sie nicht erneut  
informieren, wenn es Technologie- oder Software-Updates für unser Produkt gibt.

Sehr geehrte Benutzer,

Vielen Dank für den Kauf der Digitalanzeigen der Multifunktionsserie ·

Digitale Anzeigen werden in einer Vielzahl von Anwendungen eingesetzt. Dazu gehören Werkzeugmaschinen , in Vorschubachsen, Mess- und Prüfeinrichtungen, EDM und Messstationen für Teilapparate, Setzgeräte ,

Produktionskontrolle. Um die Anforderungen dieser

Anwendungen können viele Encoder an die Digitalanzeigen angeschlossen werden.

Lesen Sie vor der Verwendung alle Anweisungen im Handbuch sorgfältig durch und

Halten Sie sich strikt an die Anweisungen. · Bewahren Sie das Handbuch zum späteren Nachschlagen auf. ·

Sicherheitshinweis:

⚠ Um elektrischen Schlag oder Feuer zu verhindern, Feuchtigkeit oder direktes Sprühen Kühlflüssigkeit muss vermieden werden. Bei Rauch oder besonderen Geruch von der Digitalanzeige, ziehen Sie bitte den Netzstecker sofort, sonst kann es zu Feuer oder Stromschlag kommen. Versuchen Sie in einem solchen Fall nicht, das Gerät zu reparieren. Wenden Sie sich bitte an das Unternehmen oder

**distributors.**

⚠ Die Digitalanzeige ist ein präzises Messgerät mit einem optischen Lineare Skala· wenn es im Einsatz ist, wenn die Verbindung zwischen dem Lineare Skala und die Digitalanzeige sind defekt oder beschädigt extern, können falsche Messwerte entstehen · Deshalb, der Benutzer sollte vorsichtig sein.

⚠ Versuchen Sie nicht, die Digitalanzeige zu reparieren oder zu verändern, da es sonst zu Störungen, Es kann zu Störungen oder Verletzungen kommen. Im Falle eines anormalen Zustands wenden Sie sich bitte an das Unternehmen oder den Händler.

⚠ Wenn die optische Linearskala, die mit der Digitalanzeige verwendet wird, beschädigt ist, verwenden Sie keine Linearskala einer anderen Marke. · Da die Leistung, Spezifikation und Verbindung der Produkte verschiedener und CAN-Hersteller unterschiedlich sein können, darf nicht ohne Anweisung eines Fachtechnikers angeschlossen werden. Personal, sonst kommt es zu Problemen mit der Digitalanzeige.

⚠ **With the continuous updating of products, if there are changes or**

Bei Änderungen der Beispielparame-ter sind die Zufallsdateien maßgebend und das Unternehmen hat das endgültige Auslegungsrecht ohne Vorankündigung.

## Contents

---

1.	Illustration of Panel and keyboard .....	4
2.	Caption of the keyboard .....	5
3.	Parameters settings .....	7
3.1	Parameters setup routine entrance .....	7
3.2	Parameters Settings Description .....	7
3.2.1	Setting the Resolution .....	7
3.2.2	Setting Positive Direction for Counter .....	8
3.2.3	Toggle Between R/D Display Mode .....	8
3.2.4	Setting Z axis Dial .....	8
3.2.5	Setting the Rotary Radius of the Workpiece.....	9
3.2.6	Setting the Angle Display Mode .....	9
3.2.7	Setting the Baudrate of RS_232(optional) .....	9
3.2.8	Setting the Absolute Zeroing enable or disable .....	10
3.2.9	Setting the Absolute form the Special Function .....	10
3.2.10	Setting the Calculator display Mode.....	10
3.2.11	display brightness setting .....	10
3.2.12	The linear scale counting frequency setting .....	11
3.2.13	Setting QUIT .....	11
3.2.14	Setting the type of the DRO. ....	11
3.2.15	Signal Interface Type .....	11
3.2.16	Restore Factory Settings: .....	12
3.2.17	Shrinkage Ratio enable or disable.....	12
3.2.18	Setting Compensation Type .....	12
3.2.19	Inch display, set the number of digits after the decimal point...	13
3.2.20	Setting EDM(optional) .....	13
3.2.21	Setting Linearity Compensation. ....	13
3.2.22	Setting the Shrinkage Ratio .....	13
4.	General Operations .....	14
4.1	Zeroing.....	14
4.2	Preset Data to Designated Axis .....	14
4.3	Toggle Display Unit between inch and mm .....	14
4.4	Absolute/Incremental/200 groups SDM .....	15
4.5	1/2 Function .....	15
4.6	Clear All SDM Datum.....	16

## Contents

---

4.7 Sleeping Mode .....	16
4.8 Power Interruption Memory .....	16
4.9 Search the Absolute Reference Point of Scale .....	17
4.10 Non Linear Error Compensation .....	20
5、200 Groups SDM coordinate .....	21
5.1 Zeroing at the Current Point.....	21
5.2 Preset datum of SDM coordinate .....	22
6、Special Function.....	24
6.1 Circumference Holes Processing .....	25
6.2 Linear Holes Processing .....	28
6.3 ARC Processing .....	30
6.4 Oblique Processing .....	39
6.5 Slope Processng.....	43
6.6 Chamber Processing.....	44
6.7 The Tool Diameter Compensation Function .....	45
6.8 Digital Filter of the Grinding Machine .....	46
6.9 Lathe Function .....	47
6.9.1 200 sets TOOL Libs .....	47
6.9.2 Taper Function .....	48
6.9.3 R/D Function .....	49
6.9.4 Y + Z Function ( only applicable to : 3 axes Lathe).....	49
6.10 EDM.....	50
7、Calculator.....	56
8、Appendix .....	57

## Illustration of Panel and keyboard

## THREE AXIS PANEL

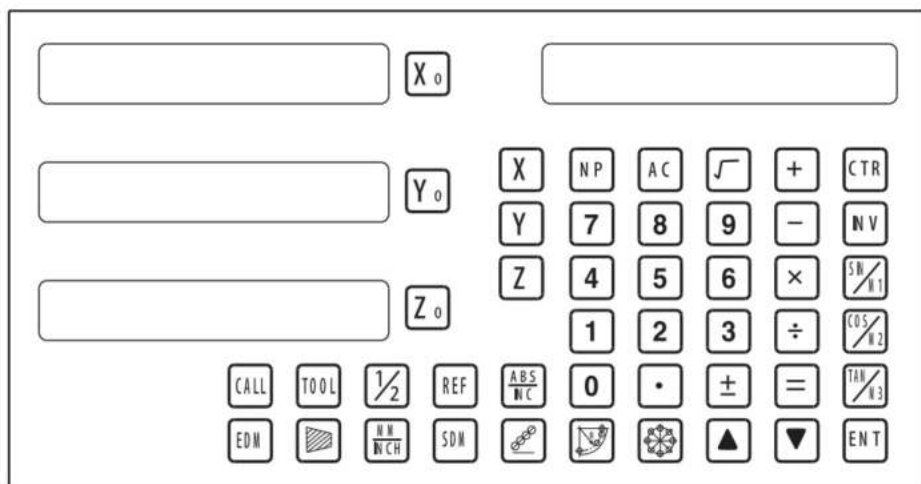



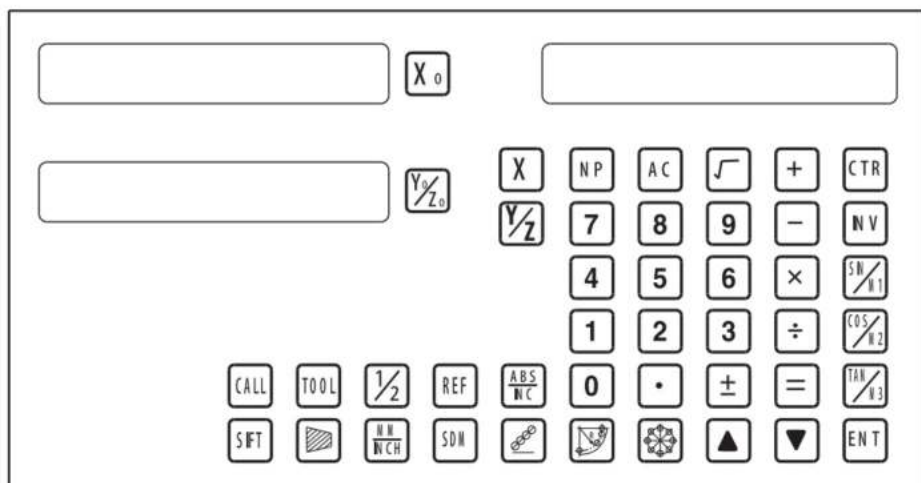









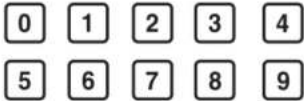



## TWO AXIS PANEL















## Caption of the keyboard

## Keyboard Description

	Keys for axis selection
	Zero select axis
	Enter +/- sign
	Enter decimal point
	Entry keys for numbers
	Operation key (in Calculation function key)
	Enter or quit calculating state
	Cancel incorrect operation
	Calculate inverse trigonometric
	Square root
	Confirm operation
	Toggles between inch and millimeter units.
	Press when ready to identify a reference mark.
	Function keys for 200 sub datum
	ARC cutting function
	holes displayed equally on a circle
	holes displayed equally on a line



## Caption of the keyboard





	Calculate trigonometric or Slope Processing function key
	Calculate trigonometric or rectangular inner chamber processing function key
	Calculate trigonometric or the tool diameter compensation function key
	Toggle between ABS/INC coordinate
	Stroll up or down to select
	Taper measured function key
	Tool library call key
	Opens the tool table.( lathe)
	EDM function key
	Filter display function key
	Half a display value of an axis
	Non Linear Error Compensation function keys

## Parameters settings

## 3. Parameters settings

## 3.1 Parameters setup routine entrance.

Press  to enter initial system and self-check after DRO powers on in 1 second, then Parameters settings display in the Parameters window. Press   to select the item you want to change.

If you want to quit initial setting, press   until "QUIT" appears in message window and press . You can also press  to quit initial setting.

## 3.2 Parameters Settings Description



## 3.2.1 Setting the Resolution

Press   until "RESOLUTE" appears in message window;

When selecting the LINEAR encode, the resolution will be set as follow:

There are 19 types of resolution:

0.01um;0.02um;0.05um;0.10um;0.20um;0.25um;0.50um;1.00um;  
2.00um;2.50um;5.00um;10.00um;20.00um;25.00um;50.00um;  
100.00um;200.00um;250.00um;500.00um.

Press  to change the resolution for X axis; Press  to change the resolution for Y axis; Press  to change the resolution for Z axis;

Set the resolution 5.00um to 1.00um for X axis:

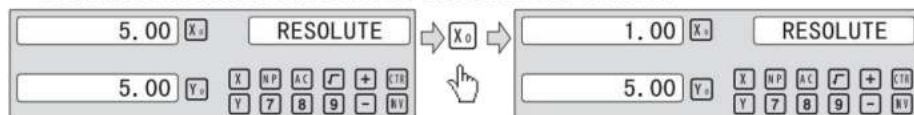

When selecting the rotary encode, the resolution will be set as follow:

Input the rotary encode parameter value .

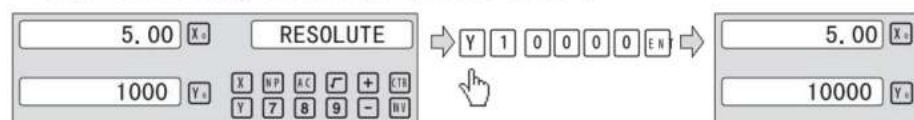

## Parameters settings

---

### 3.2.2 Setting Positive Direction for Counter

Press **▲** **▼** until “DIRECTE” appears in message window.

Direction ‘0’ means the display value will increase when scale moves from right to left and decrease when scale moves from left to right. Direction ‘1’ means the display value will increase when scale moves from left to right and decrease when scale moves from right to left.

Press **X0** to change the Direction for X axis; Press **Y0** to change the Direction for Y axis; Press **Z0** to change the Direction for Z axis; as follow:

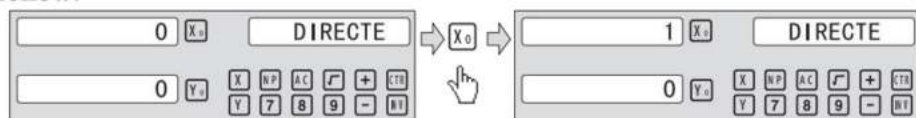

### 3.2.3 Toggle Between R/D Display Mode

Press **▲** **▼** until “R OR D” appears in message window. X window, Y window, Z window displays ‘0’ or ‘1’ separately.

‘0’ is mode R, which means the display value equals the actual measurement. ‘1’ is mode D where the display value equals the double actual measurement. Press **X0** to change the R/D for X axis; Press **Y0** to change the R/D for Y axis; Press **Z0** to change the R/D for Z axis; as follow:

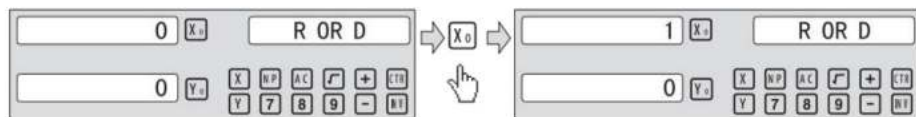

### 3.2.4 Setting Z axis Dial

Press **▲** **▼** until “Z DIAL” appears in message window.

Z axis dial should be set if Z axis is emulated for 2 axis milling and only install linear scale for X,Y axis. Z axis dial means the distance the Z axis travels when screw runs a revolution.

## Parameters settings

Set the Z axis Dial 2.5mm as follow ;



### 3.2.5 Setting the Rotary Radius of the Workpiece

Press **▲** **▼** until “RDIUS” appears in message window.

The Rotary radius type is used perimeter to measure angle.

Input the Rotary Radius parameter value 2000mm as follow:

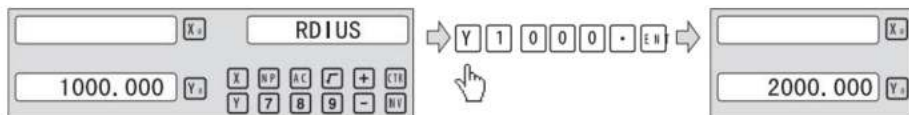

### 3.2.6 Setting the Angle Display Mode

Press **▲** **▼** until “ANG DISP” appears in message window.

Press **X0** to change the angle display mode for X axis; Press **Y0** to change the angle display mode for Y axis; Press **Z0** to change the angle display mode for Z axis; Example for X axis:

“0.0000” means the angle mode is Circulating DD;

“0000.0000” means the angle mode is Incremental DD;

“0.00.00” means the angle mode is Circulating DMS;

“0000.00.00” means the angle mode is Incremental DMS;

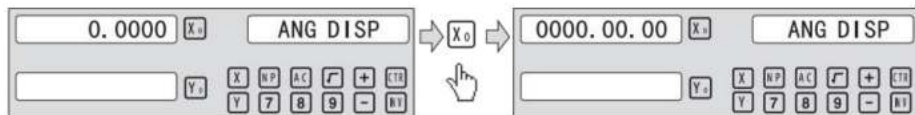

### 3.2.7 Setting the Baudrate of RS\_232 (Special customization function, if you need to buy, please contact the dealer to customize)

Press **▲** **▼** until “BAUDRATE” appears in message window.

Set the Baudrate 115200 as follow ;

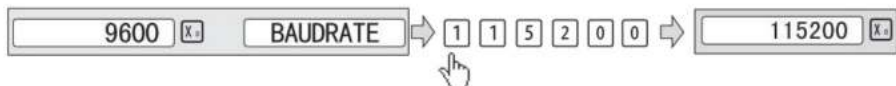



## 3.2.8 Einstellen der absoluten Nullung aktivieren oder deaktivieren

drücken   bis „ABS ZERO“ im Meldungsfenster erscheint.

Die **0** bedeutet Betrieb des ABS-Nullstellens und voreingestellte Daten werden aktivieren im normalen Anzeigezustand.

**1** bedeutet Betrieb des ABS-Nullstellens und voreingestellte Daten werden im normalen Anzeigezustand deaktivieren.

Drücken  Um den absoluten Nullungsmodus für die X-Achse zu ändern, drücken Sie  Sie, um den absoluten Nullungsmodus für die Y-Achse zu ändern. Drücken Sie  Zu

Ändern des absoluten Nullungsmodus für die Z-Achse; Beispiel für die X-Achse.

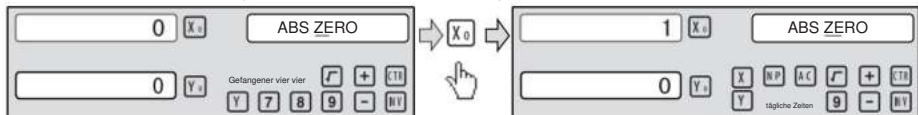

## 3.2.9 Einstellen des Absolutwertes der Sonderfunktion

drücken   bis „ABS ASST“ im Meldungsfenster erscheint.

**0** bedeutet, dass nur der Positionswert der Sonderfunktion im Sonderfunktionsbetrieb.

**1** bedeutet Sonderfunktion Positionswert + ABS Positionswert ist Anzeige im Sonderfunktionsbetrieb.

drücken  zum Ändern des absoluten Modus für die spezielle Funktion wird

wie folgt eingestellt werden:

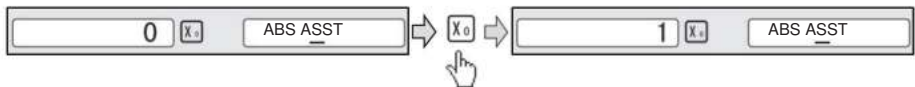
3.2.10 Einstellen der **Calculator** Anzeigemodus

drücken   bis UCCTR MODE" in der Meldung W erscheint.

Die **0** bedeutet den Rechneranzeigewert bei der x-ten Anzeige bedeutet den

**1** Rechneranzeigewert im Meldungsfenster im Display;

drücken  Um den Rechner-Anzeigemodus zu ändern, wird AS eingestellt

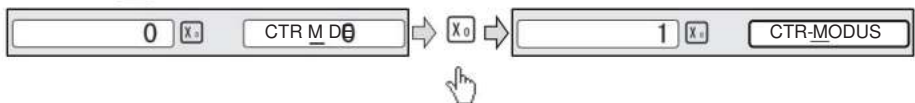

## 3.2.11 Displayhelligkeit einstellen

Einstellung der Helligkeit der LED-Anzeige, die Werkseinstellung ist nur "3", je höher der Parameter, desto heller die Helligkeit. Drücken Sie "x0", um festgelegt ist, ist es nicht empfehlenswert, den Standardwert selbst festzulegen.

## Parameters settings

## 3.2.12 The linear scale counting frequency setting

The factory default setting is only "12", the higher the parameter, the lower the counting frequency, press "X0" to set, it is not recommended that you set the default value yourself.

## 3.2.13 Setting QUIT: Digital display table parameters quit button.

## 3.2.14 Setting the type of the DRO.

The type of the DRO will be display on the right window. then press the key **ENT** to select the correct type. the following system item will be set:

"MILL-3" means the DRO type is 3-axis milling machine table;

"MILL-2" means the DRO type is 2-axis milling machine table;

"LATHE-2" means the DRO type is 2-axis lathe table;

"LATHE-3" means the DRO type is 3-axis lathe table;

"GRIND" means the DRO type is Grind table;

"EDM" means the DRO type is EDM table; (Special customization function, if you need to buy, please contact the dealer to customize)

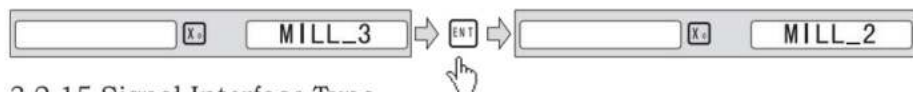

## 3.2.15 Signal Interface Type

Message window displays "SEL AXIS" which indicates the step is to Sensor input signal mode. Press **X0** to change the signal mode for X axis; Press **Y0** to change the signal mode for Y axis; Press **Z0** to change the signal mode for Z axis; Example for X axis:

Press **X0** to scroll through the Rotary encode type, the Linear encode type, the Rotary rdius type.

X window displays the Signal type.

"LInER" means the Signal type is linear encode type ;

"EnCoDE " means the Signal type is Rotary encode type;

"RdIUS" means the Signal type is Rotary rdius type ;

Example: currently in the linear encode type, to toggle to the Rotary encode type;

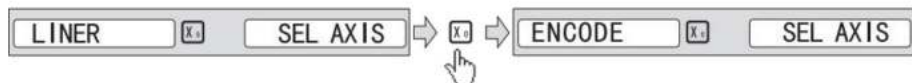

## Parameters settings

## 3.2.16 Restore Factory Settings:

Clear all data except DRO type. DRO will load default setup for parameter. After loading default setup, user must search RI once to enable resuming ABS datum function; otherwise to resume the datum by RI is unable;

Message window displays “ALL CLR”, press **ENT** and message windows display “PASSWORD” indicating the operator to input password; Press 2000 + **ENT** in turn to load default value;

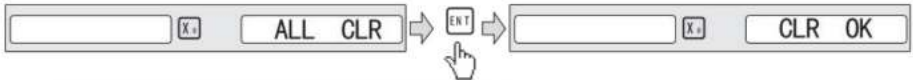

## 3.2.17 Shrinkage Ratio enable or disable.

Message window displays “SRK OFF” to disable Shrinkage rate function. Press **ENT** to enable Shrinkage rate function in Message window displays “SRK ON” :

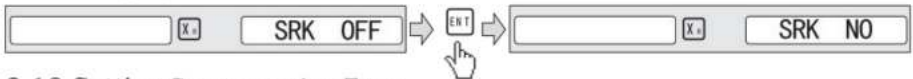

## 3.2.18 Setting Compensation Type

Message window displays “SEL COMP” which indicates the step is to compensation type. Press **X0** to change the compensation type for X axis; Press **Y0** to change the compensation type for Y axis; Press **Z0** to change the compensation type for Z axis; Example for X axis:

Press **X0** to scroll through the not compensation type, the Linear compensation type, the non-linear compensation type.

“no-CO” means the compensation type is not compensation type;

“LinE-CO” means the compensation type is linear compensation type.

“non-LinE” means the compensation type is non-linear linear compensation type;

Example for X axis: currently in the not compensation X type, to toggle to the linear compensation type;

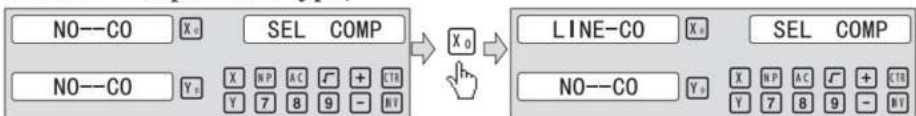

## Parameters settings

## 3.2.19 Inch display, set the number of digits after the decimal point

In the inch display mode, the number of digits after the decimal point is set, the factory default digit is "4", press "X0" to set, can be set according to actual needs.

3.2.20 Setting EDM: it is not recommended that you set the default value yourself, EDM function, Set the relay off on time.

## 3.2.21 Setting Linearity Compensation.

Message window displays "LIN COMP" which indicates the step is to Linearity Compensation. Compensate the linear error to make display value equals to standard value.

The calculation of compensation rectifying coefficient:

$$\text{Coefficient} = \frac{(\text{Measurement} - \text{Standard value}) \times 1000.000}{\text{Standard value}}$$

Example for X axis:

Measurement 200.020mm

Standard value 200.000mm

Rectifying coefficient= (200.020-200) \* 1000 /200 =-0.01mm/m

Input compensation rectifying coefficient 0.01 as follow:

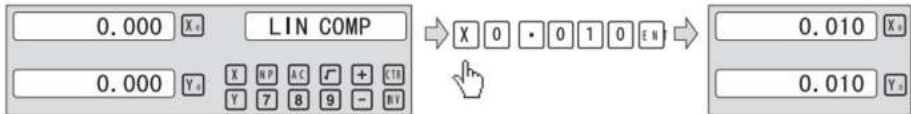

## 3.2.22 Setting the Shrinkage Ratio

Press until "SHRINK" appears in message window;

$$\text{Shrinkage ratio} = \frac{\text{Dimensions of the finished product}}{\text{Dimensions of the working piece}}$$

Set the shrinkage ratio 1.005 as follow;

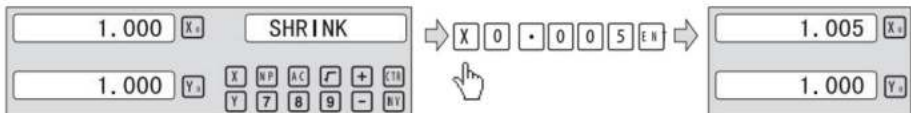







## General Operations

---

### 4、 General Operations;

#### 4.1 Zeroing









Zero the designated axis in normal display state. Zeroing is used to set the current position as datum point as follow;

key		<span style="border: 1px solid black; padding: 2px;">X<sub>0</sub></span>		X axis zero	<table style="width: 100%; border-collapse: collapse;"> <tr> <td style="width: 80%; border: 1px solid gray; padding: 2px;">0.000</td> <td style="width: 20%; border: 1px solid gray; padding: 2px;"><span style="border: 1px solid black; padding: 2px;">X<sub>0</sub></span></td> </tr> <tr> <td style="border: 1px solid gray; padding: 2px;">0.000</td> <td style="border: 1px solid gray; padding: 2px;"><span style="border: 1px solid black; padding: 2px;">Y<sub>0</sub></span></td> </tr> <tr> <td style="border: 1px solid gray; padding: 2px;">0.000</td> <td style="border: 1px solid gray; padding: 2px;"><span style="border: 1px solid black; padding: 2px;">Z<sub>0</sub></span></td> </tr> </table>	0.000	<span style="border: 1px solid black; padding: 2px;">X<sub>0</sub></span>	0.000	<span style="border: 1px solid black; padding: 2px;">Y<sub>0</sub></span>	0.000	<span style="border: 1px solid black; padding: 2px;">Z<sub>0</sub></span>
0.000	<span style="border: 1px solid black; padding: 2px;">X<sub>0</sub></span>										
0.000	<span style="border: 1px solid black; padding: 2px;">Y<sub>0</sub></span>										
0.000	<span style="border: 1px solid black; padding: 2px;">Z<sub>0</sub></span>										
key		<span style="border: 1px solid black; padding: 2px;">Y<sub>0</sub></span>		Y axis zero							
key		<span style="border: 1px solid black; padding: 2px;">Z<sub>0</sub></span>		Z axis zero							

X<sub>0</sub> or Y<sub>0</sub> or Z<sub>0</sub> will be return to the original data before the reset.

#### 4.2 Preset Data to Designated Axis



Preset a value to current position for a designated axis in normal display state.

<table style="width: 100%; border-collapse: collapse;"> <tr><td style="border: 1px solid gray; padding: 2px;">25.400</td><td style="border: 1px solid gray; padding: 2px;"><span style="border: 1px solid black; padding: 2px;">X<sub>0</sub></span></td></tr> <tr><td style="border: 1px solid gray; padding: 2px;">50.800</td><td style="border: 1px solid gray; padding: 2px;"><span style="border: 1px solid black; padding: 2px;">Y<sub>0</sub></span></td></tr> <tr><td style="border: 1px solid gray; padding: 2px;">76.200</td><td style="border: 1px solid gray; padding: 2px;"><span style="border: 1px solid black; padding: 2px;">Z<sub>0</sub></span></td></tr> </table>	25.400	<span style="border: 1px solid black; padding: 2px;">X<sub>0</sub></span>	50.800	<span style="border: 1px solid black; padding: 2px;">Y<sub>0</sub></span>	76.200	<span style="border: 1px solid black; padding: 2px;">Z<sub>0</sub></span>		 <span style="border: 1px solid black; padding: 2px;">X</span> <span style="border: 1px solid black; padding: 2px;">1</span> <span style="border: 1px solid black; padding: 2px;">8</span> <span style="border: 1px solid black; padding: 2px;">0</span> <span style="border: 1px solid black; padding: 2px;">.</span> <span style="border: 1px solid black; padding: 2px;">0</span> <span style="border: 1px solid black; padding: 2px;">1</span> <span style="border: 1px solid black; padding: 2px;">0</span> <span style="border: 1px solid black; padding: 2px;">ENT</span>		<table style="width: 100%; border-collapse: collapse;"> <tr><td style="border: 1px solid gray; padding: 2px;">180.010</td><td style="border: 1px solid gray; padding: 2px;"><span style="border: 1px solid black; padding: 2px;">X<sub>0</sub></span></td></tr> <tr><td style="border: 1px solid gray; padding: 2px;">586.010</td><td style="border: 1px solid gray; padding: 2px;"><span style="border: 1px solid black; padding: 2px;">Y<sub>0</sub></span></td></tr> <tr><td style="border: 1px solid gray; padding: 2px;">888.660</td><td style="border: 1px solid gray; padding: 2px;"><span style="border: 1px solid black; padding: 2px;">Z<sub>0</sub></span></td></tr> </table>	180.010	<span style="border: 1px solid black; padding: 2px;">X<sub>0</sub></span>	586.010	<span style="border: 1px solid black; padding: 2px;">Y<sub>0</sub></span>	888.660	<span style="border: 1px solid black; padding: 2px;">Z<sub>0</sub></span>
25.400	<span style="border: 1px solid black; padding: 2px;">X<sub>0</sub></span>															
50.800	<span style="border: 1px solid black; padding: 2px;">Y<sub>0</sub></span>															
76.200	<span style="border: 1px solid black; padding: 2px;">Z<sub>0</sub></span>															
180.010	<span style="border: 1px solid black; padding: 2px;">X<sub>0</sub></span>															
586.010	<span style="border: 1px solid black; padding: 2px;">Y<sub>0</sub></span>															
888.660	<span style="border: 1px solid black; padding: 2px;">Z<sub>0</sub></span>															
<table style="width: 100%; border-collapse: collapse;"> <tr><td style="border: 1px solid gray; padding: 2px;">25.400</td><td style="border: 1px solid gray; padding: 2px;"><span style="border: 1px solid black; padding: 2px;">X<sub>0</sub></span></td></tr> <tr><td style="border: 1px solid gray; padding: 2px;">50.800</td><td style="border: 1px solid gray; padding: 2px;"><span style="border: 1px solid black; padding: 2px;">Y<sub>0</sub></span></td></tr> <tr><td style="border: 1px solid gray; padding: 2px;">76.200</td><td style="border: 1px solid gray; padding: 2px;"><span style="border: 1px solid black; padding: 2px;">Z<sub>0</sub></span></td></tr> </table>	25.400	<span style="border: 1px solid black; padding: 2px;">X<sub>0</sub></span>	50.800	<span style="border: 1px solid black; padding: 2px;">Y<sub>0</sub></span>	76.200	<span style="border: 1px solid black; padding: 2px;">Z<sub>0</sub></span>		 <span style="border: 1px solid black; padding: 2px;">Y</span> <span style="border: 1px solid black; padding: 2px;">5</span> <span style="border: 1px solid black; padding: 2px;">8</span> <span style="border: 1px solid black; padding: 2px;">6</span> <span style="border: 1px solid black; padding: 2px;">.</span> <span style="border: 1px solid black; padding: 2px;">0</span> <span style="border: 1px solid black; padding: 2px;">1</span> <span style="border: 1px solid black; padding: 2px;">0</span> <span style="border: 1px solid black; padding: 2px;">ENT</span>		<table style="width: 100%; border-collapse: collapse;"> <tr><td style="border: 1px solid gray; padding: 2px;">180.010</td><td style="border: 1px solid gray; padding: 2px;"><span style="border: 1px solid black; padding: 2px;">X<sub>0</sub></span></td></tr> <tr><td style="border: 1px solid gray; padding: 2px;">586.010</td><td style="border: 1px solid gray; padding: 2px;"><span style="border: 1px solid black; padding: 2px;">Y<sub>0</sub></span></td></tr> <tr><td style="border: 1px solid gray; padding: 2px;">888.660</td><td style="border: 1px solid gray; padding: 2px;"><span style="border: 1px solid black; padding: 2px;">Z<sub>0</sub></span></td></tr> </table>	180.010	<span style="border: 1px solid black; padding: 2px;">X<sub>0</sub></span>	586.010	<span style="border: 1px solid black; padding: 2px;">Y<sub>0</sub></span>	888.660	<span style="border: 1px solid black; padding: 2px;">Z<sub>0</sub></span>
25.400	<span style="border: 1px solid black; padding: 2px;">X<sub>0</sub></span>															
50.800	<span style="border: 1px solid black; padding: 2px;">Y<sub>0</sub></span>															
76.200	<span style="border: 1px solid black; padding: 2px;">Z<sub>0</sub></span>															
180.010	<span style="border: 1px solid black; padding: 2px;">X<sub>0</sub></span>															
586.010	<span style="border: 1px solid black; padding: 2px;">Y<sub>0</sub></span>															
888.660	<span style="border: 1px solid black; padding: 2px;">Z<sub>0</sub></span>															
<table style="width: 100%; border-collapse: collapse;"> <tr><td style="border: 1px solid gray; padding: 2px;">25.400</td><td style="border: 1px solid gray; padding: 2px;"><span style="border: 1px solid black; padding: 2px;">X<sub>0</sub></span></td></tr> <tr><td style="border: 1px solid gray; padding: 2px;">50.800</td><td style="border: 1px solid gray; padding: 2px;"><span style="border: 1px solid black; padding: 2px;">Y<sub>0</sub></span></td></tr> <tr><td style="border: 1px solid gray; padding: 2px;">76.200</td><td style="border: 1px solid gray; padding: 2px;"><span style="border: 1px solid black; padding: 2px;">Z<sub>0</sub></span></td></tr> </table>	25.400	<span style="border: 1px solid black; padding: 2px;">X<sub>0</sub></span>	50.800	<span style="border: 1px solid black; padding: 2px;">Y<sub>0</sub></span>	76.200	<span style="border: 1px solid black; padding: 2px;">Z<sub>0</sub></span>		 <span style="border: 1px solid black; padding: 2px;">Z</span> <span style="border: 1px solid black; padding: 2px;">8</span> <span style="border: 1px solid black; padding: 2px;">8</span> <span style="border: 1px solid black; padding: 2px;">8</span> <span style="border: 1px solid black; padding: 2px;">.</span> <span style="border: 1px solid black; padding: 2px;">6</span> <span style="border: 1px solid black; padding: 2px;">6</span> <span style="border: 1px solid black; padding: 2px;">0</span> <span style="border: 1px solid black; padding: 2px;">ENT</span>		<table style="width: 100%; border-collapse: collapse;"> <tr><td style="border: 1px solid gray; padding: 2px;">180.010</td><td style="border: 1px solid gray; padding: 2px;"><span style="border: 1px solid black; padding: 2px;">X<sub>0</sub></span></td></tr> <tr><td style="border: 1px solid gray; padding: 2px;">586.010</td><td style="border: 1px solid gray; padding: 2px;"><span style="border: 1px solid black; padding: 2px;">Y<sub>0</sub></span></td></tr> <tr><td style="border: 1px solid gray; padding: 2px;">888.660</td><td style="border: 1px solid gray; padding: 2px;"><span style="border: 1px solid black; padding: 2px;">Z<sub>0</sub></span></td></tr> </table>	180.010	<span style="border: 1px solid black; padding: 2px;">X<sub>0</sub></span>	586.010	<span style="border: 1px solid black; padding: 2px;">Y<sub>0</sub></span>	888.660	<span style="border: 1px solid black; padding: 2px;">Z<sub>0</sub></span>
25.400	<span style="border: 1px solid black; padding: 2px;">X<sub>0</sub></span>															
50.800	<span style="border: 1px solid black; padding: 2px;">Y<sub>0</sub></span>															
76.200	<span style="border: 1px solid black; padding: 2px;">Z<sub>0</sub></span>															
180.010	<span style="border: 1px solid black; padding: 2px;">X<sub>0</sub></span>															
586.010	<span style="border: 1px solid black; padding: 2px;">Y<sub>0</sub></span>															
888.660	<span style="border: 1px solid black; padding: 2px;">Z<sub>0</sub></span>															



#### 4.3 Toggle Display Unit between inch and mm

Length can be displayed either in “mm” (metric) or “inch” (imperial). Display unit can be toggled between mm and inch.

Example: Display value toggle from mm to inch;

<table style="width: 100%; border-collapse: collapse;"> <tr><td style="border: 1px solid gray; padding: 2px;">25.400</td><td style="border: 1px solid gray; padding: 2px;"><span style="border: 1px solid black; padding: 2px;">X<sub>0</sub></span></td></tr> <tr><td style="border: 1px solid gray; padding: 2px;">50.800</td><td style="border: 1px solid gray; padding: 2px;"><span style="border: 1px solid black; padding: 2px;">Y<sub>0</sub></span></td></tr> <tr><td style="border: 1px solid gray; padding: 2px;">76.200</td><td style="border: 1px solid gray; padding: 2px;"><span style="border: 1px solid black; padding: 2px;">Z<sub>0</sub></span></td></tr> </table>	25.400	<span style="border: 1px solid black; padding: 2px;">X<sub>0</sub></span>	50.800	<span style="border: 1px solid black; padding: 2px;">Y<sub>0</sub></span>	76.200	<span style="border: 1px solid black; padding: 2px;">Z<sub>0</sub></span>	mm 	 <span style="border: 1px solid black; padding: 2px;">mm inch</span>		inch	<table style="width: 100%; border-collapse: collapse;"> <tr><td style="border: 1px solid gray; padding: 2px;">1.0000</td><td style="border: 1px solid gray; padding: 2px;"><span style="border: 1px solid black; padding: 2px;">X<sub>0</sub></span></td></tr> <tr><td style="border: 1px solid gray; padding: 2px;">2.0000</td><td style="border: 1px solid gray; padding: 2px;"><span style="border: 1px solid black; padding: 2px;">Y<sub>0</sub></span></td></tr> <tr><td style="border: 1px solid gray; padding: 2px;">3.0000</td><td style="border: 1px solid gray; padding: 2px;"><span style="border: 1px solid black; padding: 2px;">Z<sub>0</sub></span></td></tr> </table>	1.0000	<span style="border: 1px solid black; padding: 2px;">X<sub>0</sub></span>	2.0000	<span style="border: 1px solid black; padding: 2px;">Y<sub>0</sub></span>	3.0000	<span style="border: 1px solid black; padding: 2px;">Z<sub>0</sub></span>
25.400	<span style="border: 1px solid black; padding: 2px;">X<sub>0</sub></span>																
50.800	<span style="border: 1px solid black; padding: 2px;">Y<sub>0</sub></span>																
76.200	<span style="border: 1px solid black; padding: 2px;">Z<sub>0</sub></span>																
1.0000	<span style="border: 1px solid black; padding: 2px;">X<sub>0</sub></span>																
2.0000	<span style="border: 1px solid black; padding: 2px;">Y<sub>0</sub></span>																
3.0000	<span style="border: 1px solid black; padding: 2px;">Z<sub>0</sub></span>																

Example: Display value toggle from inch to mm;

<table style="width: 100%; border-collapse: collapse;"> <tr><td style="border: 1px solid gray; padding: 2px;">1.0000</td><td style="border: 1px solid gray; padding: 2px;"><span style="border: 1px solid black; padding: 2px;">X<sub>0</sub></span></td></tr> <tr><td style="border: 1px solid gray; padding: 2px;">2.0000</td><td style="border: 1px solid gray; padding: 2px;"><span style="border: 1px solid black; padding: 2px;">Y<sub>0</sub></span></td></tr> <tr><td style="border: 1px solid gray; padding: 2px;">3.0000</td><td style="border: 1px solid gray; padding: 2px;"><span style="border: 1px solid black; padding: 2px;">Z<sub>0</sub></span></td></tr> </table>	1.0000	<span style="border: 1px solid black; padding: 2px;">X<sub>0</sub></span>	2.0000	<span style="border: 1px solid black; padding: 2px;">Y<sub>0</sub></span>	3.0000	<span style="border: 1px solid black; padding: 2px;">Z<sub>0</sub></span>	inch 	 <span style="border: 1px solid black; padding: 2px;">mm inch</span>		mm	<table style="width: 100%; border-collapse: collapse;"> <tr><td style="border: 1px solid gray; padding: 2px;">25.400</td><td style="border: 1px solid gray; padding: 2px;"><span style="border: 1px solid black; padding: 2px;">X<sub>0</sub></span></td></tr> <tr><td style="border: 1px solid gray; padding: 2px;">50.800</td><td style="border: 1px solid gray; padding: 2px;"><span style="border: 1px solid black; padding: 2px;">Y<sub>0</sub></span></td></tr> <tr><td style="border: 1px solid gray; padding: 2px;">76.200</td><td style="border: 1px solid gray; padding: 2px;"><span style="border: 1px solid black; padding: 2px;">Z<sub>0</sub></span></td></tr> </table>	25.400	<span style="border: 1px solid black; padding: 2px;">X<sub>0</sub></span>	50.800	<span style="border: 1px solid black; padding: 2px;">Y<sub>0</sub></span>	76.200	<span style="border: 1px solid black; padding: 2px;">Z<sub>0</sub></span>
1.0000	<span style="border: 1px solid black; padding: 2px;">X<sub>0</sub></span>																
2.0000	<span style="border: 1px solid black; padding: 2px;">Y<sub>0</sub></span>																
3.0000	<span style="border: 1px solid black; padding: 2px;">Z<sub>0</sub></span>																
25.400	<span style="border: 1px solid black; padding: 2px;">X<sub>0</sub></span>																
50.800	<span style="border: 1px solid black; padding: 2px;">Y<sub>0</sub></span>																
76.200	<span style="border: 1px solid black; padding: 2px;">Z<sub>0</sub></span>																

## General Operations

### 4.4 Absolute/Incremental/200 groups SDM

Function: The DRO has 3 coordinate display modes: the absolute mode (ABS); the incremental mode (INC) and 200 groups Second Data Memory (SDM) with the range of 00 to 99. Zero point of work-piece is set at the origin point of ABS coordinate. The relative distance between datum of ABS and SDM remains unchanged when ABS datum is changed.

1. Toggle from ABS to INC coordinate;

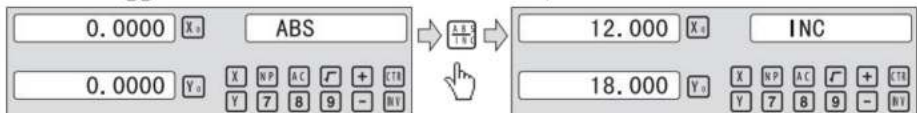

2. Toggle from INC to ABS coordinate;

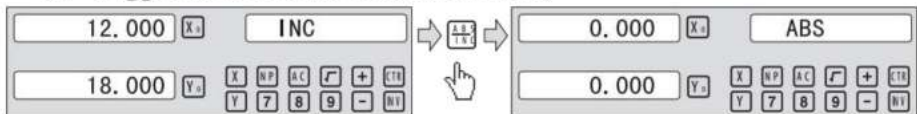

3. Toggle from SMD to ABS coordinate;

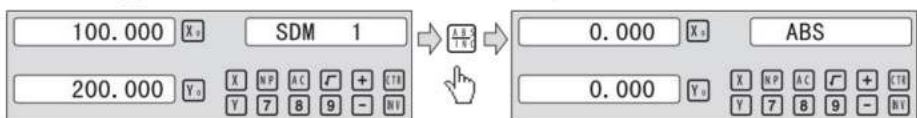

### 4.5 1/2 Function

Function: Set the center of work piece as datum by halving the displayed value.

Example: Set the center of rectangle as datum as the right figure.

Steps:

1. Touch one side of the workpiece with the TOOL, then zero the X axis.

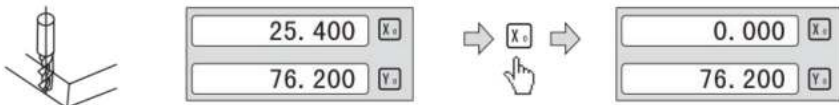

2. Gehen Sie mit dem WERKZEUG zur gegenüberliegenden Seite des Werkstücks und berühren Sie es. Drücken Sie dann **X** + **1/2** um wiederum den Anzeigewert der X-Achse zu bewerten.

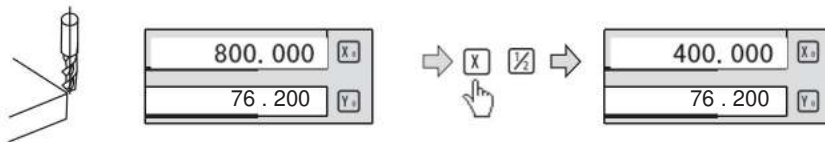

3. Bewegen Sie den Bearbeitungstisch, bis auf der X-Achse „0.000“ angezeigt wird. Fenster. Die Position ist die Mitte des Werkstücks.

4. 6 Alle SDM-Daten löschen.

Im ABS-Modus drücken Sie kontinuierlich **.** zehnmals, wird klar alle Daten für 200 Sätze SDM. Message-Fenster zeigt "USD M CLR".

4. 7 Schlafmodus

im nicht ABS-Modus, durch Drücken der Taste **E F** kann alle Displays ausschalten und der DRO in den Schlafmodus versetzt wird, dann diese Taste drücken wieder wird die DRO zurück in den Arbeitsmodus versetzt. Im Schlafmodus Modus ist die DRO noch im Arbeitszustand und zeichnet tatsächlich die WERKZEUG movement.

Beispiel: Wenn Sie sich nicht im ABS-Modus befinden, gelangen Sie in den Sleepin8-Modus, indem Sie drücken **RE**. Im Schlafmodus können Sie mit der Taste **F** den Schlafmodus beenden. **RE**

Schlafmodus ·

4. 8 Stromunterbrechungsspeicher.

Der Speicher dient zum Speichern der Einstellungen der DRO und der Maschine Referenzwerte, wenn POWER ausgeschaltet ist.

#### 4.9 Suchen des absoluten Bezugspunktes des Maßstabs

Im täglichen Bearbeitungsprozess kommt es häufig vor, dass die Bearbeitung nicht innerhalb einer Arbeitsschicht abgeschlossen werden kann, und daher die DRO nach der Arbeit ausgeschaltet werden muss, oder es kommt zu einem Stromausfall während des Bearbeitungsprozesses, der zum Verlust des Werkstückbezugs führt (Werkstücknullpunkt). Die Wiederherstellung des Werkstücknullpunktes durch die Verwendung von Kantenfindern oder anderen Methoden führt zwangsläufig zu einer höheren Bearbeitungsgenauigkeit, da es nicht möglich ist, den Werkstück-Nullpunkt exakt an der vorherigen Position wiederherzustellen. Damit ist die Wiederherstellung des Werkstückbezugspunktes sehr genau und keine erneute Ermittlung des Werkstückbezugspunktes mit Kantentaster oder anderen Methoden erforderlich. Jede Linearskala hat einen Referenzpunkt, der mit Referenz ausgestattet ist, um eine Bezugspunkt-Speicherfunktion bereitzustellen.

Das Funktionsprinzip der Referenzdatum-Speicherfunktion ist wie folgt:

Da der Referenzpunkt der linearen Skala permanent und fest ist, ändert er sich nie oder verschwindet, wenn das DRO-System ausgeschaltet ist. Daher müssen wir lediglich den Abstand zwischen dem Referenzpunkt und dem Werkstücknullpunkt im nichtflüchtigen Speicher speichern. Im Falle eines Stromausfalls oder einer Abschaltung der DRO können wir den Werkstück-Nullpunkt durch Vorgabe des Anzeige-Nullpunktes als gespeicherte Distanz vom Referenzpunkt wiederherstellen.

Bei der Bearbeitung eines Werkstückes muss ein absoluter Bezugspunkt gesetzt werden. Es gibt drei Betriebsarten (REF, AB, LEF AB):

Beispiel: Speichern des Arbeitsdatums der X-Achse.

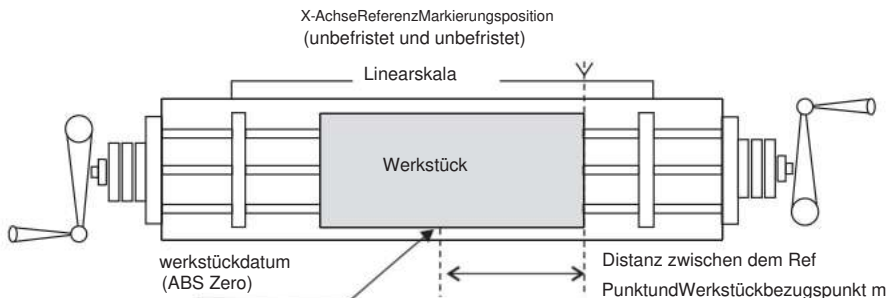

## General Operations

### Example for REF mode :

1、DRO is set in ABS coordinate. Press **REF**, then the message window display “REF” .

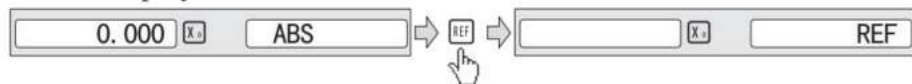

2、Message window displays “REF” , Press **ENT** until “FD\_REF” appears in message window.



3、Select the axis which need search RI. For instance : select X axis, then press **X** . “X\_REF” is displayed in message window, and X axis window flashes.

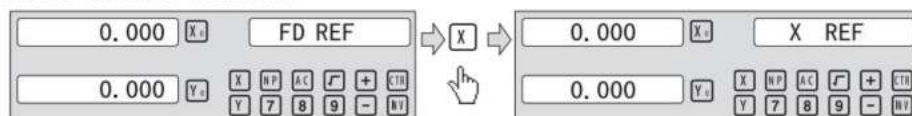

4、Move the machine table .The buzzer sounds when RI is searched, then X window stops flashing and displays the value of the current position .the DRO returns normal display state. Then message window displays “FIND\_X” .

### Example for AB mode :

1、DRO is set in ABS coordinate. Press **REF**, then the message window display “REF” .



2、Press **▲ ▼**, then the message window display “AB” .



3、Message window displays “AB” , Press **ENT** until “FIND\_AB” appears in message window.

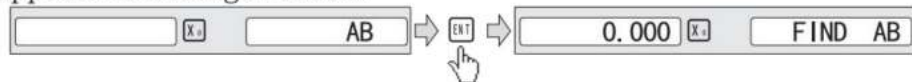

## General Operations

4、 Select the axis which need search RI. For instance : selct X axis, then press **X** . “X\_REF” is displayed in message window, and X axis window flashes.

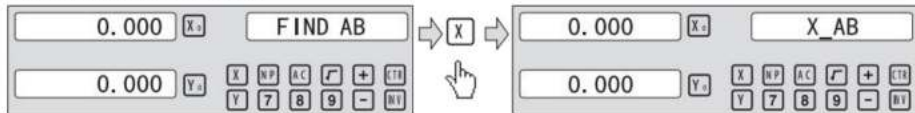

5、 Move the machine table .The buzzer sounds when RI is searched, displays the value of the current position for the absolute datum zero. the DRO returns normal display state. Then message window displays “FIND\_AB” .

### Example for LEF\_AB mode :

1、 DRO is set in ABS coordinate. Press **REF** , then the message window display “REF” .

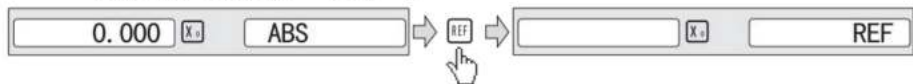

2、 Press **▲** **▼** , then the message window display “AB” .

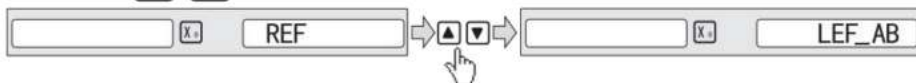

3、 Message window displays “LEF\_AB” , Press **ENT** until “ZERO\_AB” appears in message window.

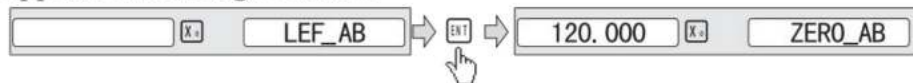

4、 Move the machine table to be set zero position piont. then press **X** , X axis will be zeroing . the current position for the absolute datum zero. the DRO returns normal display state.

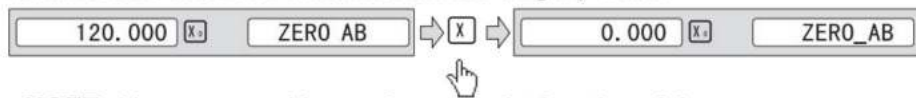

**NOTE: Linear range without reference point location of the user**

## General Operations

### 4.10 Non Linear Error Compensation

First compensation Type ( Linear or Non-Linear) in parameter setting must be set Non-Linear. Linear scale have a ref point location and find to the Absolute Reference Point will be enable.

Default Non-Linear compensation : 50.

#### Example for Y axis:

Step 1: Search the Absolute Reference Point of Scale;

Step 2: Press **[NP]** , then the message window display “COMP X” .



Step 3: Press **[▲]** **[▼]**, then the message window display “COMP Y”



Step 4: Press **[ENT]**, then the message window display “NUMBER” .

Then input the compensation parameter NUMBER.



Step 5: Press **[▲]** **[▼]**, then message window displays “Y-MSN-1” which indicates the step is to Non Linear Error Compensation.

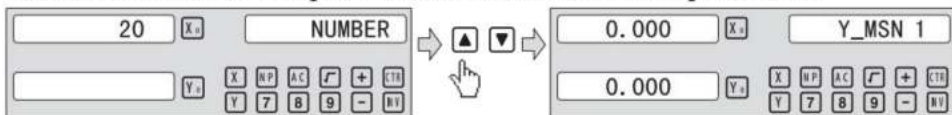

Step 6: Input compensation value .

X window display the value of the measurement value.

Y window display the value of the standard value.

Example for the first compensation point:

Measurement value :68.288mm. Standard value: 68.200mm



Step 7: After input all parameter, the DRO automatically exit.

## 5、 200 Groups SDM coordinate

The DRO has three display modes: the absolute mode (ABS), the incremental mode (INC) and the 200 groups second data memory (SDM 1 – SDM200). ABS datum of the work-piece is set at the beginning and the 200 groups SDM is set relative to ABS coordinate.

ABS Mode, INC Mode and SdM Mode are specially designed to provide much more convenience features to the operator to cope with the batch machining of relative works and the machining of the workpiece machining dimensions from more than one datum.

**Example:** The ABS datum is the center point O, the point sdm1, sdm2, sdm3, sdm4 needed processing are set as datum of SDM 1 – SDM 4.

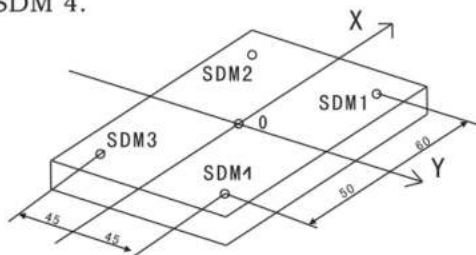

Two ways to set SDM coordinate:

- 1、 Zeroing at the Current Point.
- 2、 Preset datum of SDM coordinate.

### 5.1 Zeroing at the Current Point

At first set the center point of the work-piece as the origin of the ABS, then align the TOOL with point SDM1,SDM2,SDM3,SDM4 by moving the machine table and zero them. It is the position to process where the “0.000” appears in X window, Y window by moving the machine table whether in ABS or in SDM coordinate.

#### Steps:

- 1、 Move worktable to place the TOOL at the center of the workpiece point O as the datum of ABS. Then zero X axis and Y axis in SDM 1 ; Zero X axis and Y axis in SDM 2 ; Zero X axis and Y axis in SDM 3 ; Zero X axis and Y axis in SDM 4.

2、 Set the point sdm1 as the datum of SDM 1. Move the machine worktable to  $x = 60.000$ ,  $y = 45.000$ . Then proess  $X_0$   $Y_0$ .

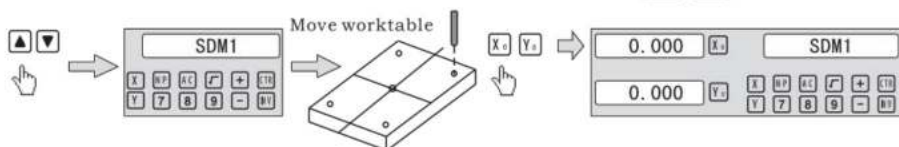

2、 Set the point sdm1 as the datum of SDM 2. Move the machine worktable to  $x = 60.000$ ,  $y = -45.000$ . Then proess  $X_0$   $Y_0$ .

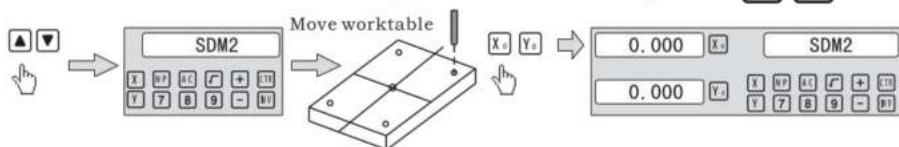

3、 Set the point sdm1 as the datum of SDM 3. Move the machine worktable to  $x = -60.000$ ,  $y = -45.000$ . Then proess  $X_0$   $Y_0$ .

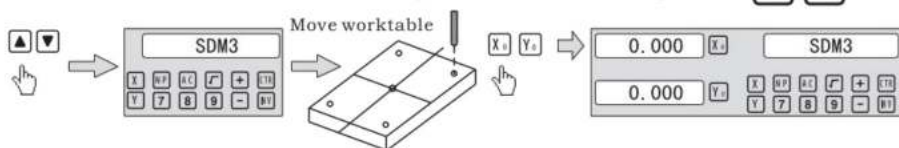

4、 Set the point sdm1 as the datum of SDM 4. Move the machine worktable to  $x = -60.000$ ,  $y = 45.000$ . Then proess  $X_0$   $Y_0$ .

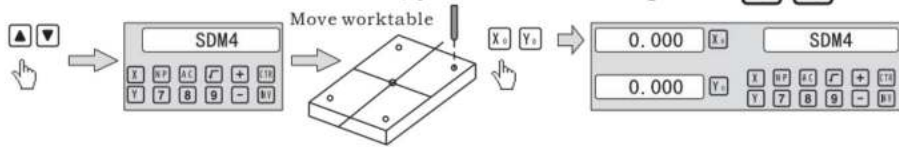

## 5.2 Preset datum of SDM coordinate

There are the same sample as Method 1. First Move the worktable to place the TOOL exactly at the origin of ABS, secondly Enter the ABS Mode as follow.

### Steps:

1、 Move worktable to place the TOOL at the center of the workpiece point O as the datum of ABS. Then zero X axis and Y axis in SDM 1 ; Zero X axis and Y axis in SDM 2 ; Zero X axis and Y axis in SDM 3 ; Zero X axis and Y axis in SDM 4.

## 200 Groups SDM coordinate

2、 Set point sdm1 as the datum of SDM 1. Press  $\blacktriangle$   $\blacktriangledown$ , then the message window display “SDM 1” . Input  $x = 60.000$ ,  $y = 45.000$ .

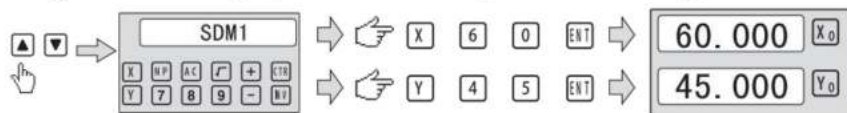

3、 Set point sdm1 as the datum of SDM 2. Press  $\blacktriangle$   $\blacktriangledown$ , then the message window display “SDM 2” . Input  $x = -60.000$ ,  $y = 45.000$ .

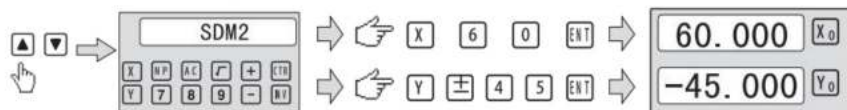

4、 Set point sdm1 as the datum of SDM 3. Press  $\blacktriangle$   $\blacktriangledown$ , then the message window display “SDM 3” . Input  $x = -60.000$ ,  $y = -45.000$ .

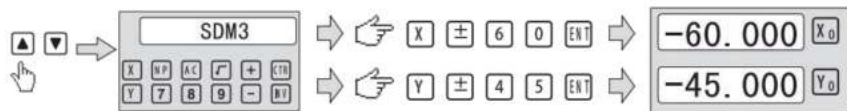

5、 Set point sdm1 as the datum of SDM 4. Press  $\blacktriangle$   $\blacktriangledown$ , then the message window display “SDM 4” . Input  $x = -60.000$ ,  $y = 45.000$ .

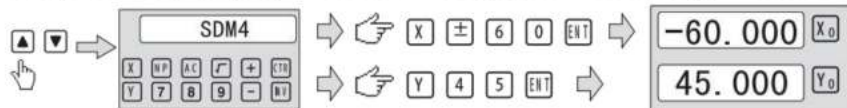

## Sonderfunktion

---

### 6. Sonderfunktion

## Circumference Holes Processing

### 6.1 Circumference Holes Processing

The Function of PCD Hole positioning on Circumference is used to distribute arc equally, such as boring hole on flange. The right window will show the parameter to be defined when selecting PCD Function.

The Parameters to be defined are:

PCD_XY(XZ,YZ)	Select place
CENTER	Center position
DIA	Diameter of circle
NO_HOLE	Hole number
ST ANG	Starting angle
ED ANG	Ending angle

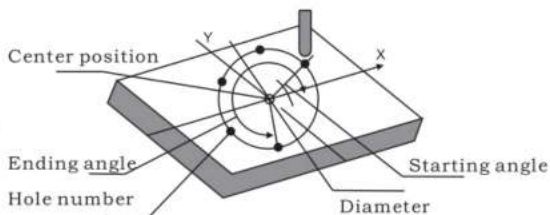

The position of the hole center are calculated automatically after input all parameters. Press or to choose the hole No. and move the machine table until the “0.000” appears in X window , Y window, Z window. It is the position to process a table.

Example for the XY place: Machine hole on circumference as the figure

PCD_XY(XZ,YZ)	XY
CENTER	X=0,000,Y=0.000
DIA	100,000
NO_HOLE	5
ST ANG	30,000
ED ANG	315,000

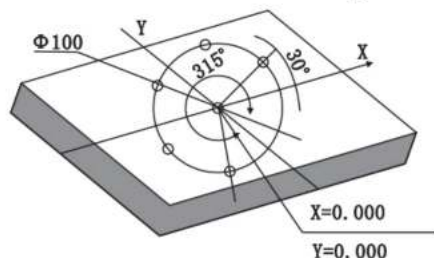

Steps:

1. Set display unit to metric in normal state; Move the machine table until the machine TOOL is aligned with the center of the circle , then zero X axis ,Y axis.

2. Select place.

Press , then the message window display “PCD\_XY” to the Circumference Holes Processing. Press or to select XY place.



## Circumference Holes Processing

## 2. Input center position.

Press **ENT**, then the message window display “CENTER”. X and Y window displays the formerly preset center position. Input X = 0, Y = 0 as follow.

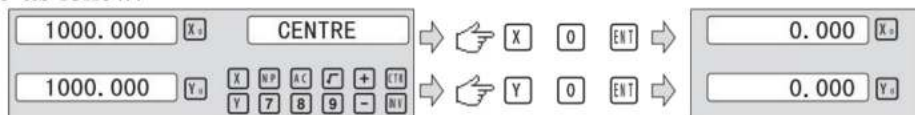

## 4. Input diameter.

Press **▼** until “DIA” appears in the message window. X window displays the formerly preset diameter. Then input the diameter is 100.000.

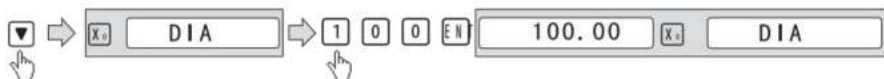

## 5. Input number.

Press **▼** until “NO\_HOLE” appears in the message window. X window displays the formerly preset number. Then press **5** in turn to input number.



## 6. Input starting angle.

Press **▼** until “ST ANG” appears in the message window. X window displays the formerly preset the starting angle. Then press **3** **0** in turn to input the starting angle.



## 7. Input ending angle.

Press **▼** until “ED ANG” appears in the message window. X window displays the formerly preset the ending angle.. Then press **3** **1** **5** in turn to input the ending angle.

## Circumference Holes Processing



8. Press  until “NO 1” appears in the message window.

It is the position of the first hole to punch where the “0.000” is displayed in X window and Y window by moving the machine table.

After finishing the first hole, press  or  to change holes number.

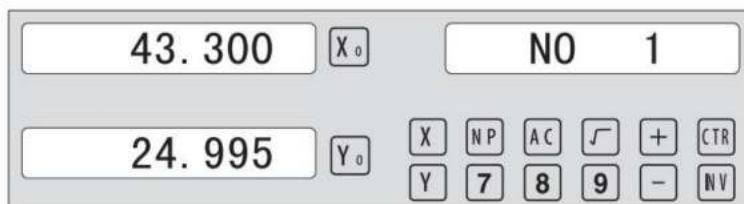

9. After processing all holes, press  to return normal display.

## Linear Holes Processing

### 6.2 Linear Holes Processing

There are two modes to carry out the linear drilling: Length mode and Step mode.

1.LINE S	Step mode
LINE L	Length mode
2.STEP	Step length
LENGTH	Line length
3. ANG	Angle
4. NO.HOLE	Hole number

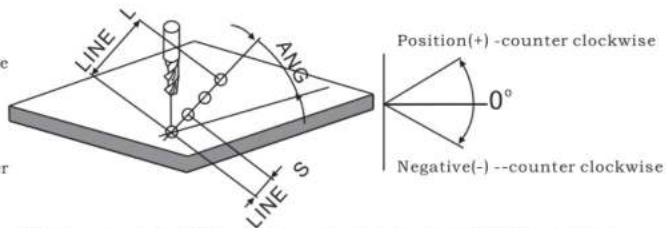

Linear Holes function can simplify the processing multiple holes whose centers are attributed equally on one line.

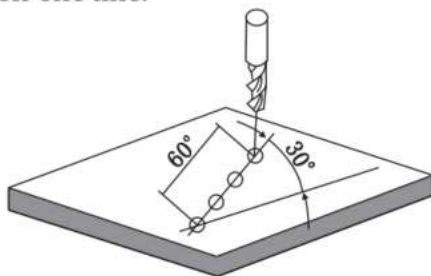

Example :

LINE_L	Length mode
LENGTH	60.000
ANG	30.000
NO.HOLE	4





Steps :

1. Select piece.

Press , then the message window display "LINE\_XY" to the Linear Holes Processing. Press  or  to select XY place.



2. Select Linear Holes mode.

Press , then the message window display "LINE\_S". Press  or  to select "LINE\_L".



3. Input linear length;

Press , then the message window display "LENGTH".

## Linear Holes Processing

X window displays the formerly preset the linear length. Press **6** **0** in turn to input the linear length.

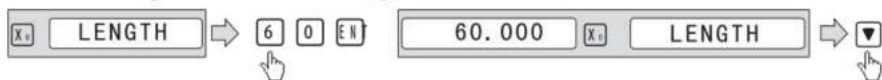

## 4. Input angle;

Message window displays “ANG” which indicates the step is to angle. X window displays the formerly preset the angle. Press **3** **0** in turn to input the angle.

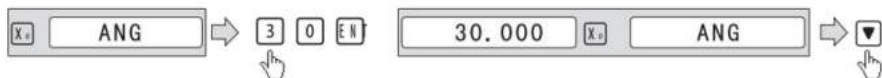

## 5. Input number;

Message window displays “ANG” which indicates the step is to angle. X window displays the formerly preset the number. Press **4** in turn to input the number.



6. Press **▼** until “NO 1” appears in the message window.

It is the position of the first hole to punch where the “0.000” is displayed in X window and Y window by moving the machine table. After finishing the first hole, press **▲** or **▼** to change holes number.

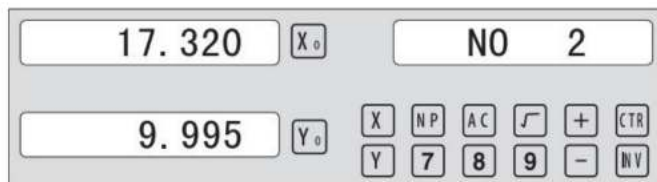

7. After processing all holes, press **☒** to return normal display.

## 6.3 ARC-Verarbeitung

Für die ARC-Funktion stehen ZWEI Funktionen zur Verfügung: die einfache ARC

Funktion und die glatte R-Funktion · drücken Sie dann pr css



um die ARC-Funktion aufzurufen,



oder



zur Auswahl der Smooth ARC-Funktion oder der einfachen

ARC-Funktion.

Bei der Installation werden normalerweise die Koordinaten der Maschine und der Richtung von X, Y , Z sind wie folgt. Die Arbeitsebene wird als rechte Abbildung.

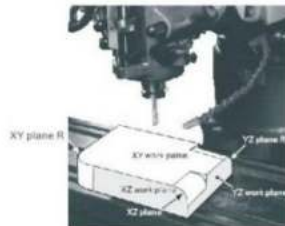
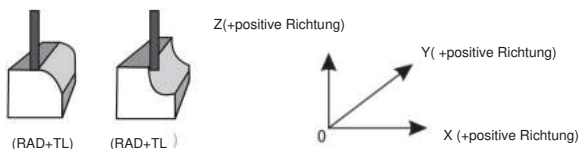

einfache ARC-Funktion:

wenn die Glätte nicht sehr hoch gefordert ist, der SIMPLE ARC

Die Funktion wird normalerweise für die Bearbeitung von Bögen verwendet. In der Funktion SIMPLE

Es gibt nur acht Arten von ARC, die zur Bearbeitung verwendet werden. Der Bediener

Wählen Sie den Typ R und geben Sie die Parameter für den Radius des Bogens ein ,

MAX CUT und äußerer Qrc oder innerer Bogen. Im Allgemeinen kann ein Bogen

bearbeitet durch einen ebenen Schlitz T OOL Oder arc TOOL, der Unterschied zwischen in verschiedenen Arbeitsebenen, wie im Folgenden gezeigt ·

- |     |                   |                              |
|-----|-------------------|------------------------------|
| 1 , | EINFACH           | einfache Verarbeitung        |
| 2 , | TYP 1 - 8         | Modus des ARC.               |
| 3 , | SEL_XY(XZ, YZ)    | Ort auswählen<br>Bogenradius |
| 4 , | RAD               | Werkzeugdurchmesser          |
| 5   | TL IHN            | Vorschubschritt              |
| 6.  | MAXIMALER SCHNITT | Außenbogen und               |
| 7   | RAD TL _          | innerer Bogen                |

(nur für Ort xy)

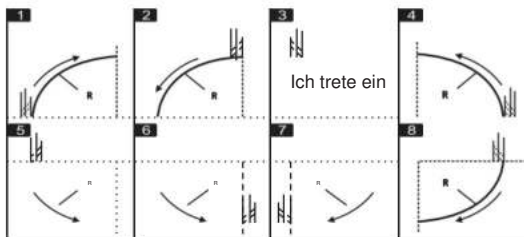

## ARC Processing

---

### Smooth ARC function :

Provides maximum flexibility in ARC machining, the ARC sector to be machined by the coordinates of ARC. Very flexible, ARC function can machine virtually all kinds of ARC, ever the intersected ARC. Relatively a bit complicated to operate, operator need to calculate and enter the coordinates of ARC centre, start angle and end angle.

Basic parameter as follow:

1. SMOOTH	Mode of the Smooth ARC processing;
2. SEL_XY(YZ, XZ)	Select place;
3. CENTER	Refer to the position of an center.
4. RAD	Radius of the ARC
5. TL_DIA	Diameter of the TOOL
6. MAX_CUT	Feed step
7. ST_ANG	Starting angle
8. ED_ANG	Ending angle
9. RAD+TL	Outer arc.
RAD-TL	Inner arc.

### Example 1 for the Simple ARC Processing:

Parameters settings as follow:

SIMPLE	Simple mode
TYPE	3
SEL_XY	XY
RAD	80.000
TL_DIA	6.000
MAX_CUT	0.500
RAD+TL	1

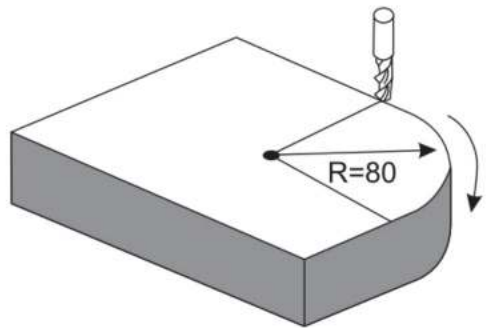

### Steps:

1. Select process mode

Press  , then the message window display “SIMPLE” to the ARC Processing. Press  or  to select mode of the simple, The message window display “SIMPLE”

## ARC Processing



2. Input the type:

Press **ENT** until “TYPE” appears in the message window. X-window displays the formerly preset type. Press **3** in turn



3. Select place

Press **ENT** until “SEL\_XY” appears in the message window.

Press **▲** or **▼** to select place to display “SEL\_XY”;



4. Input radius:

Press **ENT** until “RAD” appears in the message window. X-window displays the formerly preset the radius of ARC. Press **80** in turn to input the radius.;



5. Input Diameter of the TOOL

Press **▲** or **▼** until “TL DIA” appears in the message window. X-window displays the formerly preset the Diameter of the TOOL. Press **6** in turn to input the Diameter value;







6. Input Feed step (MAX\_CUT);



Press **▲** or **▼** until “MAX\_CUT” appears in the message window. X-window displays the formerly preset the MAX\_CUT. Press **0.5** in turn to input the MAX\_CUT value;



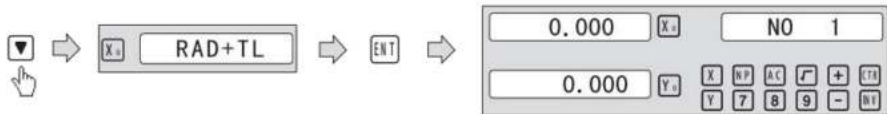

## ARC Processing

## 7. Select outer arc or inner arc

Press  or  until “RAD-TL” appears in the message window. Press  or  to select place to display “RAD+TL” ;

8. After inputting all parameters, press the key  for machining.

The DRO will display the position of the first point. Retract the axes until the displays read 0.000, Machine the Arc point by point in accordance with the display. After finishing the position of the first point, press  or  to change position point.

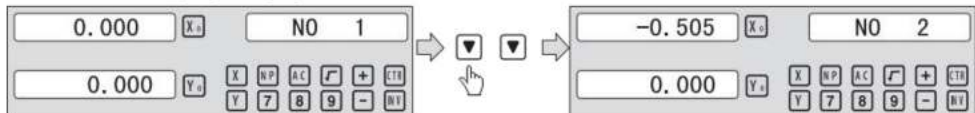

Press  to quit R function any time.

**Example 2 for the Simple ARC Processing:**

Parameters settings as follow:

SIMPLE	Simple mode
TYPE	3
SEL_XY	XZ .....
RAD	80.000 .....
TL_DIA	6.000 .....
MAX_CUT	0.500 .....

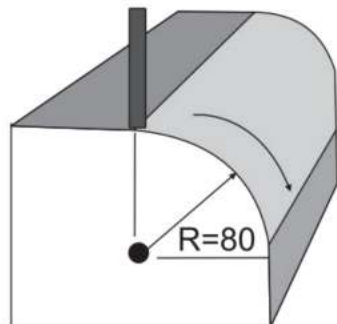

Steps:

1. Press , then the message window display “SIMPLE” to the ARC Processing. Press  or  to select mode of the simple, The message window display “SIMPLE”

## ARC Processing



2. Input the type:

Press **ENT** until “TYPE” appears in the message window. X-window displays the formerly preset type. Press **3** in turn



3. Select place

Press **ENT** until “SEL\_XZ” appears in the message window.

Press **▲** or **▼** to select place to display “SEL\_XZ” ;



4. Input radius:

Press **ENT** until “RAD” appears in the message window. X window displays the formerly preset the radius of ARC. Press **80** in turn to input the radius.;



5. Input Diameter of the TOOL

Press **▲** or **▼** until “TL DIA” appears in the message window. X window displays the formerly preset the Diameter of the TOOL. Press **6** in turn to input the Diameter value;



6. Input Feed step (MAX\_CUT);

Press **▲** or **▼** until “MAX\_CUT” appears in the message window. X window displays the formerly preset the MAX\_CUT. Press **0.5** in turn to input the MAX\_CUT value;



## ARC Processing

7. After inputting all parameters, press the key **ENT** for machining.

For 2-axis milling machine table, It is not installed with Z-axis, please press **▲** or **▼** to simulate position of Z-axis. Press **▲** simulate moving to the former process, and press **▼** simulate moving to the next process point.

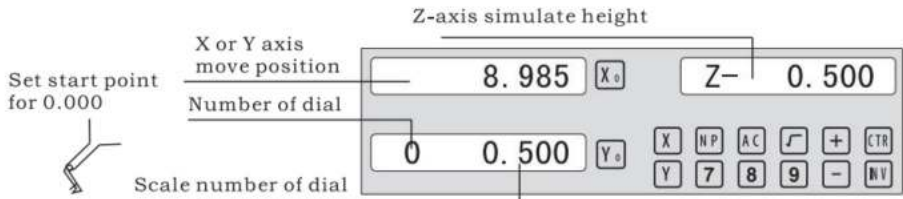

Z-axis simulate height = Number of dial x Z axis Dial + Scale number of dial

Press **▼** to quit R function any time.

### Example 3 for the Smooth ARC function:

Parameters settings as follow:

SMOOTH	Smooth mode
SEL_XY(YZ,XZ)	XY
CENTER	X=0,Y=0
RAD	80.000
TL_DIA	6.000
MAX_CUT	0.500
ST_ANG	0.000
ED_ANG	135.000
RAD+TL	1

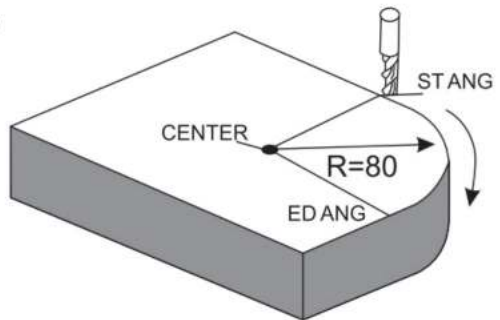

Steps:

1. Press **▼**, then the message window display "SIMPLE" to the ARC Processing. Press **▲** or **▼** to select mode of the simple, The

## ARC Processing

message window display “SMOOTH” ; For 3-axis milling machine table without this step. In second step. Then press **ENT** .



### 2. Select place

Message window display “SEL\_XY” which indicates the select is to place. Press **▲** or **▼** to select place to display “SEL\_XY” ;

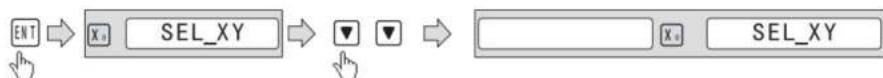

### 3. Input center position.

Press **ENT** , then the message window display “CENTER” . X and Y window displays the formerly preset center position. Input X = 0, Y = 0 as follow.

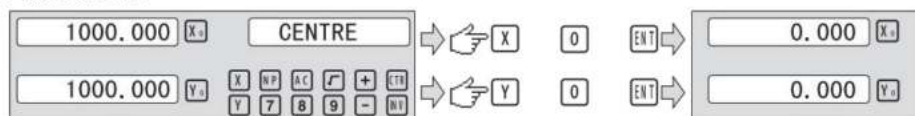

### 4. Input radius:

Press **ENT** until “RAD” appears in the message window. X window displays the formerly preset the radius of ARC. Press **8** **0** in turn to input the radius.;



### 5. Input Diameter of the TOOL



Press **▲** or **▼** until “TL DIA” appears in the message window. X window displays the formerly preset the Diameter of the TOOL. Press **6** in turn to input the Diameter value;



6. Vorschubschritt eingeben (MAX\_CUT);

drücken  oder  bis UMAX CUT App Autos" in der Nachricht

Fenster. X Fenster de spa lys die zuvor voreingestellte MAX\_CUT. drücken

   um wiederum den MAX CUT-Wert einzugeben;

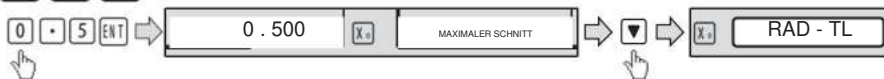

7. Startwinkel eingeben .

drücken  bis USTANG" im Meldungsfenster erscheint.x

Fenster de spa lys die zuvor voreingestellten Startwinkel . Dann drücken Sie

 wiederum zur Eingabe des Startwinkels-

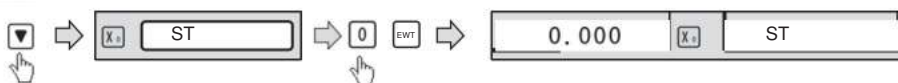



8 . Endwinkel eingeben .

drücken  bis „UED ANG“ im Meldungsfenster erscheint. X

Fenster zeigt den zuvor voreingestellten Endwinkel an. Drücken Sie dann





  um wiederum den Endwinkel einzugeben-



9. Wählen Sie den äußeren oder inneren Bogen

Drücken  oder  bis "RAD-TL" in der Meldung erscheint

Sie window.press  oder  um den Ort für die Anzeige von „RAD+TL“ auszuwählen;

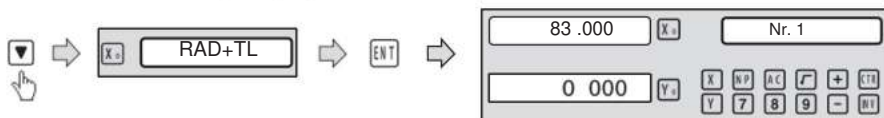

10. Nach Eingabe aller Parameter,

**machining.**

Die DRO zeigt die Position des ersten Punktes an. Ziehen Sie den

Achsen bis die Anzeigen 0 . 000 anzeigen, Bearbeiten Sie den Bogen Punkt für Punkt in  
entsprechend der Anzeige. Nach Abschluss der Position des ersten

Punkt, drücken  oder  um den Positionspunkt zu ändern.

## ARC Processing

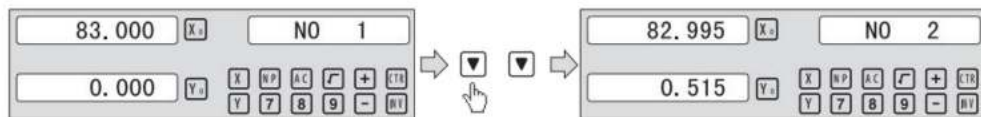

Press  to quit ARC function any time.

## 6. 4 Schrägbearbeitung

Für die Bearbeitung schräger Stellen stehen zwei Möglichkeiten zur Verfügung:

A). an der Stelle. b). an der Stelle yz oder Xz;

es müssen lediglich folgende Parameter eingegeben werden:

INKL. <u>X</u> y(xz,yz)	Maschinenort xy,yz,Orxz festlegen ·
DER	Der Neigungswinkel der Schräge·
DORT	Der WERKZEUG-Durchmesser ·
ST <u>P</u> OT	Startposition;
ED <u>K</u> ANN	Ende der Veröffentlichung;

Beispiel 1 für die schräge xy-Position:

wenn die Bearbeitungsebene auf der xy-Ebene liegt, wie das in

Abbildung: Der Neigungswinkel des Werkstücks sollte kalibriert werden

bevor die schräge Ebene bearbeitet wird. Daher , an diesem Punkt die

Die Bearbeitung der schrägen Ebene dient der Kalibrierung der Schiefe ·

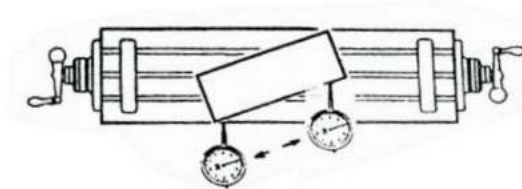

Verfahren zur Kalibrierung der Schiefe

Platzieren Sie zunächst das Werkstück im gewünschten Winkel auf dem Arbeitstisch.

der Schrägheit ·

- 1) Geben Sie die Funktion der schrägen Ebene ein.
- 2) Wählen Sie die Funktion der XY-Ebene.
- 3) Geben Sie den Neigungswinkel ein·

- 4) Bewegen Sie den Arbeitstisch, bis das Messwerkzeug (z. B. eine Messuhr)

Wenn die auf der Fräsmaschine installierte Ebene die Neigungskalibrierungsebene-berührt, wird sie auf Null gestellt und der Arbeitstisch wird um eine beliebige Distanz in der Richtung der x-Achse.



- 5) Verschieben Sie den Arbeitstisch in der Entfernung dery-Achse bis die Anzeige wird auf Null.

## Oblique Processing

6) Change the angle of the work piece to make the workpiece touch the measuring tool and adjust it to zero.

STEPS:



1. Select place

Press , then the message window display "INCL\_XY" to the Oblique Processing. Press  or  to select place to display "SEL\_XY";

Then press  to in next step;



2. Input the angle of obliquity

The message window display "ANG" , X window displays the formerly preset the angle of obliquity. Press   in turn to input the angle of obliquity .



3. Move the workpiece along the X-Axis until the measuring tool touches the workpiece adjust it to zero, and move the worktable for any distance along the X-Axis.



4. Press , display the value of Y-Axis. Move the workpiece along the Y-Axis, change the angle of workpiece to make the obliquity-calibrating plane touch the measuring tool until it turns to zero. Move the worktable until Y-Axis is displayed as zero.

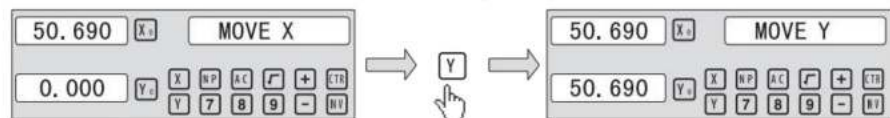

5. Press  to quit oblique function any time.

## Oblique Processing

### Example 2 for the oblique XZ or YZ place:

When the machining plane is on plane XZ or YZ, the function of TOOL inclination can instruct the operator to machine the oblique plane step by step.



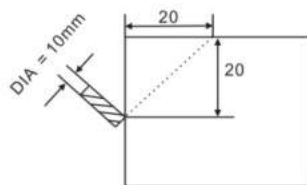
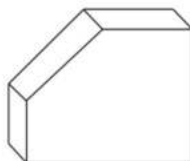

Procedures for using the function of cutter inclination:

When the machining plane is on plane XZ or YZ, first please calibrate the obliquity of the primary spindle nose and set the TOOL:

INCL_XY(XZ,YZ)	INCL_XZ
DIA	10.000
ST_POT	20.000
ED_POT	20.000





#### STEPS:

1. Press , then the message window display “INCL\_XY” to the oblique Processing. Press  or  to select place to display “SEL\_XZ; Then press  to in next step;



2. Input The TOOL Diameter

The message window display “DIA” , X window displays the formerly preset the angle of obliquity. Press   in turn to input the TOOL Diameter of obliquity . OK, then press  to in next step;



3. Input ST\_POT;

The message window display “ST\_POT” , X and Y window displays the formerly preset the stating position of obliquity. Input X= 0, Y = -20.000. OK, then press  to in next step;

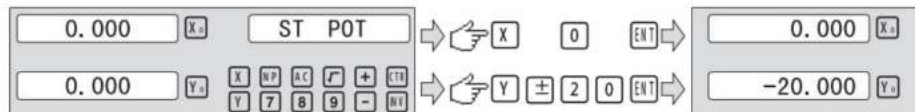



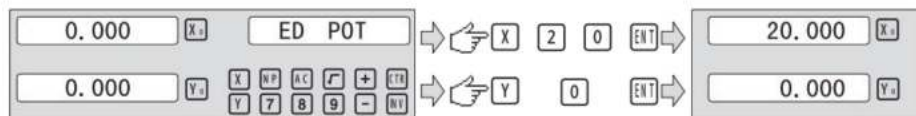

## Oblique Processing

### 4. Input ED\_POT;

The message window display “ED\_POT” , X and Y window displays the formerly preset the starting position of obliquity. Input X= 20.000, Y = 0.000 .



### 5. After input all parameter, press the key for machining.

For 2-axis milling machine table , It is not installed with Z-axis, please press  or  to simulate position of Z-axis. Press  simulate moving to the former process, and press  simulate moving to the next process point.



Z-axis simulate height = Number of dial x Z axis Dial + Scale number of dial

Press  to quit **oblique** function any time.

## Slope Processing



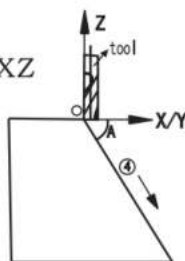

## 6.5 Slope Processing

This function can calculate the position of every processing point automatically in processing slope. Only the following parameters need to be inputted:

XZ, YZ	Set machine place YZ, or XZ
ANG	The inclination angle
Z_STEP	The slope length each time processing



**Example 1 for the Slope XZ place;**

Step 1. Select place

Press , then the message window display “XZ” to the slope Processing. Press  or  to select place to display “SEL\_XY; Then press  to in next step;





Step 2. Input the angle of slope

The message window display “ANG”, X window displays the formerly preset the angle of slope. Press   in turn.



Step 3. Input Z\_step;

The message window display “Z STEP”, X window displays the formerly preset the stating position of slope. Input    in turn.



Step 4:Finishing the ALL processing . Press  to quit slope function any time.

## Chambering Processing

### 6.6 Chambering Processing

1,FLAT\_XY: machine place; 2, DIA:diameter of TOOL; 3, CENTER: center of the chambering ; 4, SIZE: size of the chambering ;

Figure as follow:

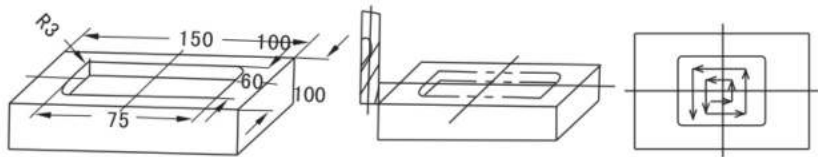

STEPS:

1. Press , then the message window display “FLAT\_XY” to the Chambering Processing.



2. Input DIA of the TOOL;





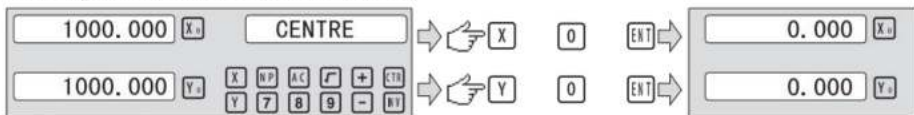

3. Input the center coordinate;

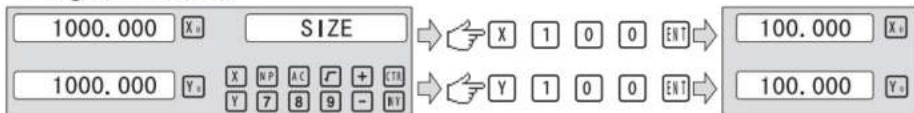

4. Input the size;



5. process Chambering;

Move the machine until the display of the axis is zero,ie, the position of the first point. Machine the first point . Display the next machining point by pressing  or  .On the completion of machining, the right window shows OVER. Press  or , the system will goto the first position for the next workpiece. Press  to quit the Chambering Function.

## The Tool Diameter Compensation Function

### 6.7 The Tool Diameter Compensation Function

Without TOOL compensation, the operator has to move the TOOL for an additional distance of the diameter of the TOOL along each side when machining the four 150 and 100 sides of a workpiece to finish machining the whole brim. The digital readouts shall automatically compensate when the TOOL compensation function is enable.

Note: the TOOL compensation is made in the direction of X and Yaxis.

Procedures:

- 1) . Enter the function of compensating the diameter of the TOOL.
- 2) . Select one of the (four) preset machining modes.
- 3). Input the diameter of the TOOL.
- 4) . Enter machining.

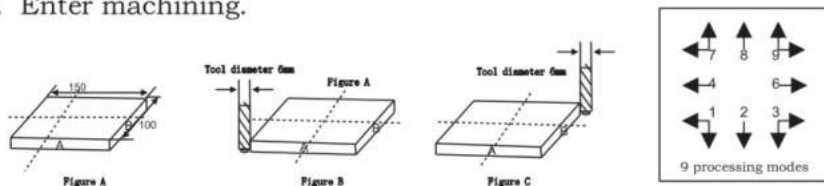

Step1: press  $\frac{D}{1}$  to enter the TOOL compensation Function. then the message window display “TYPE” .Press **9** .



Step 2: input the diameter of the TOOL; Press **1** **0** in turn..



Step 3: Press  $\nabla$  to the machining Mode.

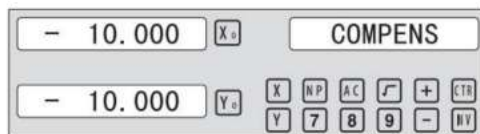

Machining of 2 side planes can be done by moving the TOOL until X-Axis is 150.000 and Y-Axis is 100.000.Press the Key  $\frac{D}{3}$  to quit the Function.

## The Tool Diameter Compensation Function

---

### 6.8 Digital Filter of the Grinding Machine

When machine a work-piece by grinder, the display values quickly due to the vibration of grinder. User can not see display value clearly. Grinder DRO provides display value filter function to disable the quake change of display value.

STEPS:

1. Enter display value filter function.

In normal display state, press **SFT** to simultaneously, enter display value filter function.

2. Exit display value filter function;

Press **SFT** , exit display value filter function;

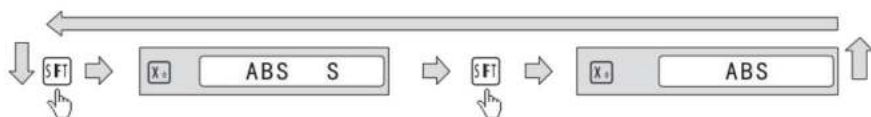

## 6.9 La die Funktion

### 6.9.1 200 Sätze TOOL-Bibliotheken

Es werden immer unterschiedliche WERKZEUGE für die Bearbeitung unterschiedlicher Teile benötigt. komfortable Bedienung, die La die Digitalanzeigen hat die Funktion der 200 Sätze TOOL-Bibliotheken ·

Hinweis: Nur wenn die Maschine mit dem Werkzeug-Einstellblock ausgestattet ist, können die 200 Sätze Werkzeugbibliotheken verwendet werden.

1. Setzen Sie ein Bezugswerkzeug. Nach der Werkzeugeinstellung, Nullung der X- und Z-Achse, Nullpunkt der absoluten Koordinate setzen ·

2. Bestimmen Sie anhand der Größe von TOOL I und datumTOOL die Position von TOOL relativ zum Nullpunkt der absoluten Koordinate und des Bezugswerkzeugs · AS Abbildung

6-1. Die relative Größe von TOOL 2 ist AS folgt der x-Achse  $25-30=-5$

, Z-Achse  $20-10=10$  ·

3. Speichern Sie die Werkzeugnummer und die Größe in der Digitalanzeige ·

4. Die Anzahl der WERKZEUGE kann beliebig eingegeben werden, die digitalen Anzeigen zeigt die Position des Werkzeugs zur absoluten Koordinate Null an · Bewegen Sie bis sowohl die X-Achse als auch die Z-Achse Null anzeigen · 5.

TOOL Libs können 200 Werkzeugdatensätze speichern.

6. Die TOOL Libs müssen im Eröffnungszustand verwendet werden. Die 200 Sätze Rooi Libs können durch kontinuierliches Drücken geöffnet werden  zehnmal

bis im rechten Fenster TL - OPEN blinkt und eine Markierung "21" angezeigt wird links vom rechten Informationsfenster. Die Markierung zeigt die

Der Bediener kann die 200 TOOL-Bibliotheken kontinuierlich einrichten oder überarbeiten.

Drücken der Taste  Zehnmaliges Ausführen führt dazu, dass die 200sets TOOL Libs geschlossen und im rechten Fenster blinkt TL - CLOSE und die Markierung

verschwinden · wenn die Markierung "21" verschwindet, können die 200 Sätze TOOL Libs nicht überarbeitet werden.

Die Vorgänge für TOOL-Daten und das Aufrufen von TOOL werden wie folgt angezeigt: · Schritt

1: Geben Sie im ABS-Zustand die Daten der 200 TOOL-Bibliothekssätze ein.

Öffnen der 200 Sätze TOOL Libs durch anhaltendes Drücken der Taste

 Zehnmal erscheint die Markierung "" im linken Fenster des rechten Infenster.

## Lathe Function

Schritt 2: Drücken Sie **TOOL** um auf den Eingabestatus zuzugreifen. Daten von Raum 1 eingeben:

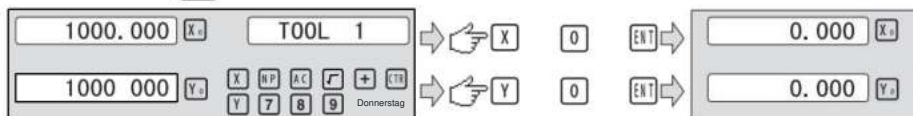

Schritt 3: TOOL 2 Daten eingeben:

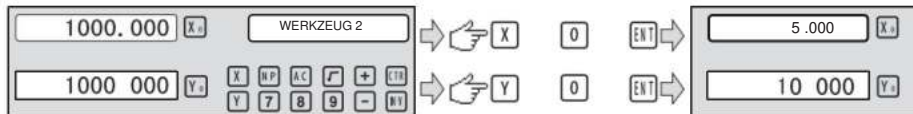

Schritt 4: Drücken Sie **PR**, um mit der Eingabe der Daten des nächsten Werkzeugs fortzufahren.

Nummer und Schlüssel **Y** kann der Bediener direkt die Sonderfunktion eingeben

Werkzeugdaten.Presse **TOOL** Berührungen

Nach dem Einrichten der TOOL-Bibliotheken - verwenden Sie die TOOL-Bibliotheken gemäß den

Bei den folgenden Arbeitsgängen montieren Sie zuerst das zweite Werkzeug .



Schritt G: Drücken Sie **▲** oder **▼** . Wählen Sie die Basisrolle. Drücken Sie dann **1** **UND T** .



Schritt 7: Drücken Sie **CALL** um die Funktion zu beenden;

Notiz:

- wenn das Basiswerkzeug verwendet wird , die Achse kann im ABS-Zustand nicht auf Null gesetzt werden .
- wenn die anderen verwendet werden , Die Achse kann nur im Zustand INC auf Null gesetzt werden .

### 6.9.2 Taper-Funktion

Beim Drehen des Werkstücks mit Kegel kann der Kegel des Werkstücks in der Verarbeitung gemessen werden;

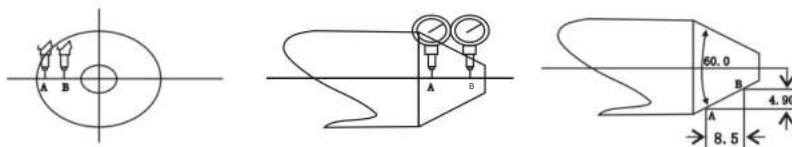

## Lathe Function

### Operations :

AS-Abbildung, Kontaktfläche A des Werkstücks mit Hebelanzeigen und setzt den Zeiger der Hebelanzeige auf Null zurück ·

Schritt 1: Drücken Sie  dann die Meldungsanzeige "UMEASU" auf die Papierverarbeitung · Bewegen Sie den Hebel zur Oberfläche B, bis der Hebelanzeigen zeigen auf AS wie folgt;



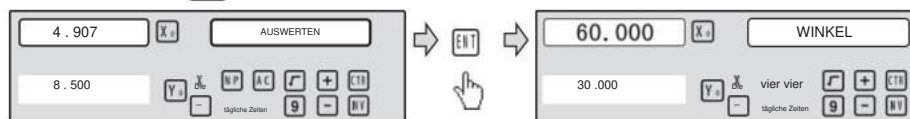

Schritt 2: Drücken Sie  zum Berechnen.



Schritt 3: Drücken Sie  um die Funktion zu beenden;

### 6 . 9 . 3 R/D-Funktion

Für 2 xes Drehmaschine und 3 Achsen Drehmaschine, Presse  , Der Anzeigemodus ofx-Achse wird zwischen Radius und Durchmesser umgeschaltet. wenn x-Achse für Anzeige von Durchmesser, A markieren Sie  " erscheint links von rechts u Informationsfenster, aber wenn X-Achse für die Anzeige von ia Meter , die Marke " " verschwinden · nur die x-Achse hat die Funktion des Durchmessers / Radius transformation.

### 6 . 9 . 4 Y + Z Funktion ( gilt nur für : 3 Achsen La the)

Für 3 Achsen La der Zähler der y-Achse und der Zähler der z-Achse

Kann durch Drücken der Taste zur Anzeige in der Z-Achse hinzugefügt werden  , dann die Taste C drücken und die y + Z Funktion abrechenen ·

6.10 EDM (spezielle Anpassungsfunktion, wenn Sie kaufen müssen, bitte kontaktieren Sie den Händler zur Anpassung)

1 Beschreibung: Diese Funktion dient zur Spezialbearbeitung von Elektroerosive Bearbeitung (EDM). Wenn der eingestellte Zielwert von EDM Z-Achse ist gleich dem aktuellen Wert, die digitale Anzeige gibt den Schaltsignal zur Steuerung des EDM, um die Tiefenbearbeitung zu stoppen.

Die Einstellung der Z-Achsenrichtung auf der Digitalanzeige ist in Abb. 1 dargestellt, d. h. je tiefer die Tiefe ist, desto größer ist der Koordinatenwert der Z-Achse zeigt · seit Beginn der Bearbeitung wird die Tiefe allmählich größer und Z-Achse.

Die Bearbeitungsrichtung ist je nach eingestellter Z-Achsenrichtung unterteilt in positive und negative Bearbeitung · wenn die Elektrode senkt sich und die Bearbeitung erfolgt von oben nach unten, die digitale Der Anzeigewert erhöht sich, was als positive Bearbeitung (positiv) bezeichnet wird. Die Einstellung dieser Richtung ist die normale Einstellung ·

wenn die Elektrode ASCEnds und die Bearbeitung durchgeführt wird von unten nach oben wird der digitale Anzeigewert kleiner · Der Die Bearbeitungsrichtung ist die negative Richtung (negativ), die auch als Negativbearbeitung (siehe Abb. 1)

Die Digitalanzeige bietet außerdem weitere Funktionen, so negativ Feuerfeste Höhe. Negative Feuerfeste Höhe Funktion ist eine Art von intelligente Position Follow Check Sicherheitsschutzeinrichtung. Dabei der Bearbeitung, die Elektrodenoberfläche erzeugt den Kohlenstoff Ansammlungsphänomen. Aufgrund der langen Zeit oder der täglichen Bearbeitung ohne Pflege, bei der Erzeugung der Kohlenstoffansammlung und niemand macht die Reinigung, die Elektrode wird langsam entlang der negative Richtung · sobald die Elektrode den Flüssigkeitspegel überschreitet, wird sie fangen häufig Feuer und verursachen Verluste. Diese Funktion ist nur darauf ausgerichtet, bei diesem Problem. bei der Einstellung einer negativen Feuerschutzhöhe und der Die erhöhte Höhe der Elektrode übersteigt die Höhe zwischen ihr und der Tiefe der bearbeiteten Oberfläche (d. h. negative feuerfeste Höhe), die digitale Die Anzeige blinkt für WQring; gleichzeitig wird die Ausgabe Signal schaltet EDM automatisch ab, um die Brandgefahr auszuschließen ·



Abbildung 1



## 2. Vorgehensweise:

Eine detaillierte Bearbeitung finden Sie im folgenden Beispiel

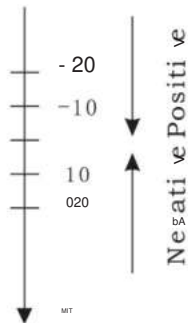
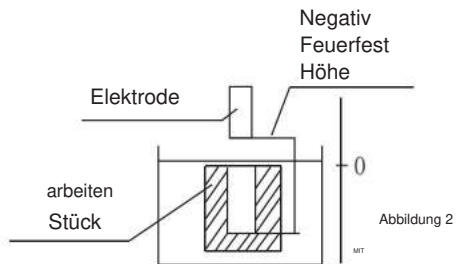
- 1) Vor der Bearbeitung stellen Sie zunächst jeden Parameter von DEPTH ein (Bearbeitungstiefe);ERRHIGH(negative feuerfeste Höhe), Bearbeitung Richtung (POSITIV / NEGATIV); Modus verlassen (AUTO/STOP) und EDM Relaisausgangsmodus · 2)

Bewegen Sie die Hauptachselektrode der Z-Achse, so dass sie den Werkstückreferenz · A-Achse auf Null setzen bzw. Wert setzen ·

- 3) Geben Sie EDM-Bearbeitung ein, indem Sie den Schlüssel pr css verwenden 

4) Auf der X-Achse wird der Zielwert für die Bearbeitungstiefe angezeigt. Auf der Y-Achse Anzeigewert war Tiefe. (Der Wert auf der Y-Achse ist der Wert, dass das Werkstück bearbeitet wurde Tiefe) Z-Achse wird Anzeige des Echtzeitwertes der Eigenposition. (Der Wert auf der Z-Achse ist der Positionswert der Hauptachselektrode der Z-Achse.)

5) starten bearbeitung, Z-achse display wert ist allmählich in der nähe der Zielwert, undy-Achsen-Anzeigewert ist auch allmählich in der Nähe der Zielwert. Wenn zu diesem Zeitpunkt die Elektrode wiederholt auf und ab bewegt wird, ändert sich der Anzeigewert auf der Z-Achse anschließend, aber der Anzeigewert auf der Y-Achse Wert ändert sich nicht, es wird immer die bearbeitete Tiefe angezeigt **value.**

- 6) Wenn der Anzeigewert der Z-Achse dem eingestellten Zielwert entspricht, Position erreicht Schalter wird ausgeschaltet, EDM wird die Bearbeitung stoppen, Je nach Einstellung des Betreibers gibt es zwei Arten von Beendigungsmodi:

## a) Automatic Mode:

it will automatically exit from EDM machining status and recover to the original state before machining;

## b) Stop Mode:

It will always stay at the machining interface after finishing machining, and you should press **EDM** to exit and back to the original state.

**Operation steps:**

**The DEPTH (machining Depth), ERRHIGH (Negative fireproof height), exit Mode, EDM Relay Output Mode and machining direction should be set.**

**STEPS:**

1. Press **EDM** to enter the EDM Function. Press **▲** to input parameters; Press **▼** to enter EDM machining state.

2. Input DEPTH ( machining depth). Press the key **▲** to set the next parameter.



3. input ERRHIGH ( Negative Fireproof Height ) (undefine) .Press the key **▲** to set the next parameter.



4. Set machining direction(Positive or Negative). Press **1** to select Positive direction. Press **0** to select Negative direction. Press the key **▲** to set the next parameter.



## EDM

5. Set exit Mode (AUTO Mode or STOP Mode) Press **0** to select AUTO Mode; Press **1** to select STOP Mode ; Press the key **▲** to set the next parameter.

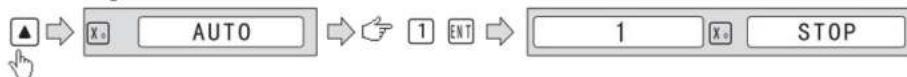

6. Set the Output Mode (Mode 0 or Mode 1); ( undefine ). Press **0** to select Mode 0; Press **1** to select Mode 1.



7. Continuously press **▼** to return EDM for machining. press **EDM** to quit the function;

### Example 1: positive direction machining ;

Machining is shown as the model chamber as follows

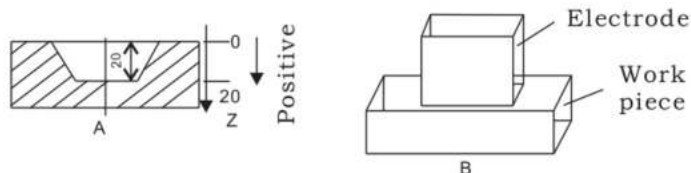

#### STEPS:

1、Touch one side of the workpiece with the TOOL, then press **Z0** , zero the Z axis.



2、 Press **EDM** , Setting DEPTH for 20.000; press **▼** to EDM for machining;



3、 Starting machining.

## EDM

Machining depth target value	20.000	X <sub>0</sub>	EDM RUN
Value has been to be depth	0.000	Y <sub>0</sub>	
Self-position real time value	0.000	Z <sub>0</sub>	

**Example 2: Negative direction machining**

Machining is shown as the model chamber as follows

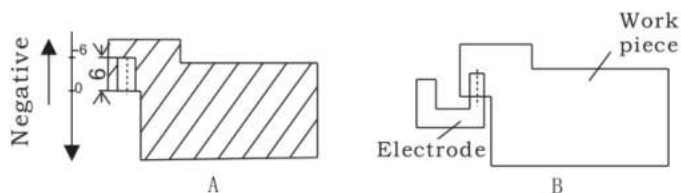

- 1、Touch one side of the workpiece with the TOOL, then press **Z<sub>0</sub>** , zero the Z axis.

1000.000	Z <sub>0</sub>	→	→	Z <sub>0</sub>	→	0.000	Z <sub>0</sub>
----------	----------------	---	---	----------------	---	-------	----------------

- 2、Press **EDM** , Setting DEPTH for -20.000; press **▼** to EDM for machining;

EDM	→	X <sub>0</sub>	DEPTH	→	→	±	2	0	ENT	→	-20.000	X <sub>0</sub>	DEPTH
-----	---	----------------	-------	---	---	---	---	---	-----	---	---------	----------------	-------

- 3、Starting machining.

Machining depth target value	20.000	X <sub>0</sub>	EDM RUN
Value has been to be depth	0.000	Y <sub>0</sub>	
Self-position real time value	0.000	Z <sub>0</sub>	

**Example 3: PCD Function for EDM**

PCD Function can access the EDM Function . The operator enters PCD Function to input parameters for PCD and enter PCD machining state. At every position for machining, press the key **EDM** to access the EDM Function .

Beim Aufrufen der EDM-Funktion kann der Bediener die Parameter eingeben

für Funkenerosion ·



Der Betriebsablauf ist wie folgt:



1) PCD-Parameter einstellen (die Einstellung ist die gleiche wie die allgemeine Einstellung von PCD)

Nach Eingabe aller Parameter und Aufruf des PCD-Bearbeitungsstatus ·

Die Position des ersten Lochs wird angezeigt.

2) Drücken  um den EDM-Funktionsparameter einzugeben (die Einstellungsmethode ist Sie die gleiche Taste wie bei der allgemeinen Einstellung des EDM-Parameters); nach Eingabe aller

Parameter, gedrückt halten, wenn die  um in den EDM-Bearbeitungszustand zu Bearbeitung abgeschlossen ist, drücken, um  wechseln. um die EDM-Funktion zu beenden und den PCD-Bearbeitungsstatus einzugeben ·

3) Im PCD-Bearbeitungszustand drücken Sie  für die Position des nächsten Lochs, OVE die Maschine auf den Anzeigewert 0 , dann pr css  Zugang

EDM-Funktion erneut · 4)

Wiederholen Sie Schritt 2 und Schritt 3 für die folgenden Bearbeitungspunkte.

## Calculator

### 7 Taschenrechner

Der Rechner bietet nicht nur normale mathematische Berechnungen

wie  $+$ ,  $-$ ,  $\times$ ,  $/$ , es bietet auch trigonometrische Berechnungen wie AS  
SÜNDE, Arc SIN, COS, Bogen-COS, BRÄUNEN, Arc TAN SQRT usw.

Die Bedienung ist dieselbe wie bei handelsüblichen Taschenrechnern und einfach zu bedienen.

#### Rechnerfunktion aufrufen und beenden

Im normalen Anzeigezustand: Drücken Sie R, um die Rechnerfunktion aufzurufen.

im Rechneranzeigezustand: Drücken Sie R, um die Rechnerfunktion zu verlassen.

Die Rechnerergebnisse werden für die ausgewählten Werte übertragen.

Wenn die Berechnung abgeschlossen ist und der Anzeigemodus des Rechners auf

**Modus 1**, Der Benutzer kann:

Das **X<sub>0</sub>** um das berechnete Ergebnis auf die x-Achse zu übertragen; dann wird die x-  
Pressefenster zeigt diesen Wert an.

drücken **Y<sub>0</sub>** um das berechnete Ergebnis auf die Achse zu übertragen; dann  
Das Fenster zeigt diesen Wert an.

Das **Z<sub>0</sub>** um das berechnete Ergebnis auf die Z-Achse zu übertragen; dann wird die Z-Achse  
Pressefenster zeigt diesen Wert an.

#### Übertragen des aktuellen Anzeigewertes im Fenster zum Rechner.

wenn der Rechner Anzeigemodus auf Modus 1 eingestellt ist, Der Benutzer kann:

drücken **X** um den Anzeigewert im X-Fenster an den Rechner zu übertragen;

drücken **Y** um den Anzeigewert im Y-Fenster zu übertragen, um r zu berechnen;

drücken **Z** um den Anzeigewert im Z-Fenster an den Rechner zu übertragen;

## Appendix

## 8 Appendix

## 1. Troubleshooting:

The following are the preliminary solvents for troubleshooting.

If there is still trouble, Please contact out company or agents for help.

Troubles	Possible reasons	Solvents
No display	<ol style="list-style-type: none"> <li>1. Power isn't connected</li> <li>2. Power switch is off.</li> <li>3. The range of power voltage is not right.</li> <li>4. The inner power of Linear Scale is short.</li> </ol>	<ol style="list-style-type: none"> <li>1. Check power wire and connect the power</li> <li>2. Turn on the power switch.</li> <li>3. The range of voltage is in 80--260V</li> <li>4. Unplug the connector of linear scale</li> </ol>
One axis is not counting	<ol style="list-style-type: none"> <li>1. Replace the linear scale of the other axis.</li> <li>2. DRO is in special function</li> </ol>	<ol style="list-style-type: none"> <li>1. If count is normal, the linear scale has trouble; If abnormal, the DRO readouts has trouble.</li> <li>2. Quit the special function.</li> </ol>
Linear scale is not counting	<ol style="list-style-type: none"> <li>1. Reading head is bad for using range exceeds.</li> <li>2. Aluminum chips is in reading head of linear scale.</li> <li>3. The span between the reading head and metal part of linear scale is large.</li> <li>4. The metal parts of linear scale is damage.</li> </ol>	<ol style="list-style-type: none"> <li>1. Repair the linear scale</li> <li>2. Repair the linear scale</li> <li>3. Repair the linear scale</li> <li>4. Repair the linear scale</li> </ol>
Counting is error	<ol style="list-style-type: none"> <li>1. Shell is poor grounding.</li> <li>2. Low precision of machine.</li> <li>3. Speed of machine is too rapid.</li> <li>4. Precision of linear scale is low.</li> <li>5. The resolution of DRO readouts and the linear scale is not match.</li> <li>6. The unit (mm/inch) is not match.</li> <li>7. Setting the linear compensating is not arrest.</li> <li>8. Reading head of the linear scale is damaged.</li> </ol>	<ol style="list-style-type: none"> <li>1. Shell is good grounding.</li> <li>2. Repair the machine.</li> <li>3. Reduce the speed of machine.</li> <li>4. Mount the linear scale again.</li> <li>5. Set the resolution of the DRO again.</li> <li>6. Cover the unit of display mm/inch.</li> <li>7. Reset the linear compensation.</li> <li>8. Repair the linear scale.</li> </ol>
The counting of the linear scale is not accurate	<ol style="list-style-type: none"> <li>1. The mounting of linear scale does not demand the requirement, and the prcision is not adequate.</li> <li>2. The screw is loosen.</li> <li>3. Precision of machine is low.</li> <li>4. The resolution of digital readouts and the linear scale is not match.</li> </ol>	<ol style="list-style-type: none"> <li>1. Mount the linear scale again and level it.</li> <li>2. Lock all fixing screws.</li> <li>3. Repair the machine.</li> <li>4. Reset the resolution of digital readouts.</li> </ol>
Sometimes the linear scale is not counting	<ol style="list-style-type: none"> <li>1. The small car and steel ball is separated.</li> <li>2. The glass of reading head is wearied.</li> <li>3. The glass of reading head of the linear scale has dirt.</li> <li>4. The elasticity of the steel wire is not adequate.</li> </ol>	<ol style="list-style-type: none"> <li>1. Repair the linear scale.</li> <li>2. Repair the linear scale.</li> <li>3. Repair the linear scale.</li> <li>4. Repair the linear scale.</li> </ol>

## Appendix

### 2. Specifications of Digital Readout.

- 1) Supply Voltage range: AC 85 V ~ 230 V; 50 ~ 60 Hz
- 2) Power consumption: 15VA
- 3) Operating temperature: 0°C-- 50°C
- 4) Storage temperature: - 30°C-- 70°C
- 5) Relative humidity: < 90 % ( 25 )
- 6) Max Coordinate number: 3
- 7) Readout allowable input signal: TTL square wave
- 8) Allowable input signal frequency: < 5 M Hz
- 9) Max resolution of digital display length: 0.01 um
- 10) Max resolution of digital display angle: 0.0001 / PULSE

### 3. Instructions

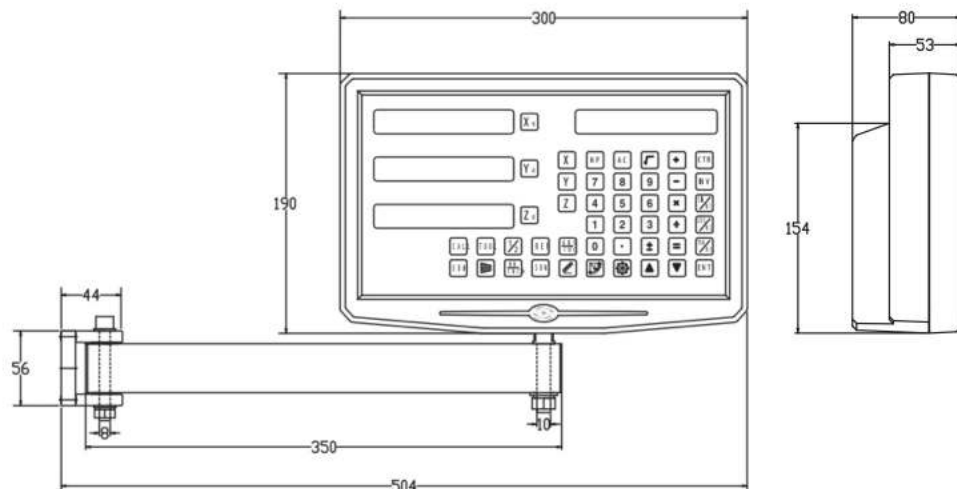

## 4. Examples of character output at the data interface

## 1、 X,Y,Z Axis

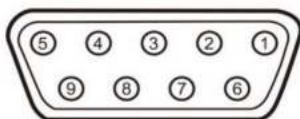

Pin	TTL (Standard)
1	
2	0V
3	
4	
5	
6	A+
7	5V
8	B+
9	R+

Pin	TTL (Standard)
1	5V
2	0V
3	A+
4	B+
5	R+
6	
7	
8	
9	

For your convenience,  
If you buy a digital readout,

The wiring definition of your linear scale must be the same as the 2 definitions in the above diagram to be universal!

# Installation Instructions

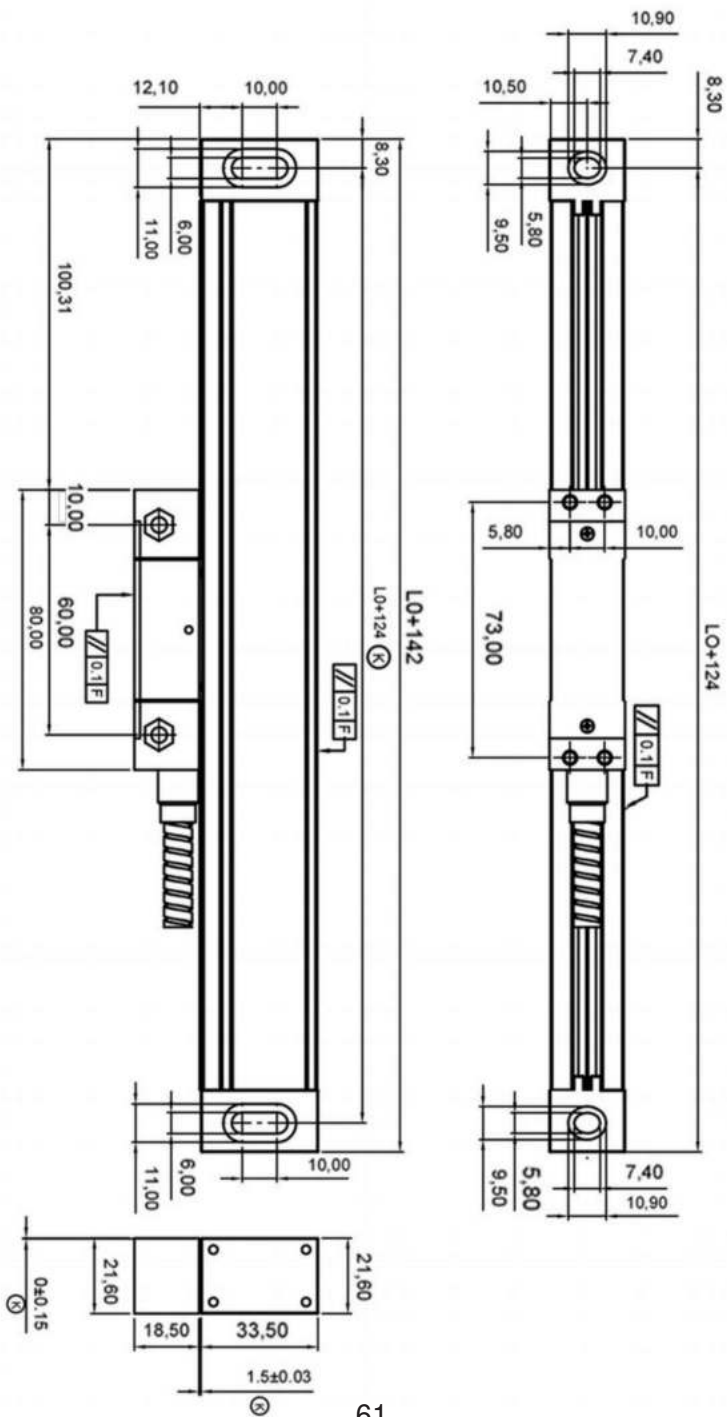

## TTL signal Output:

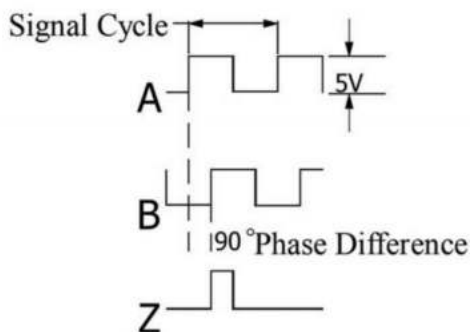

## EIA-422-A signal Output:

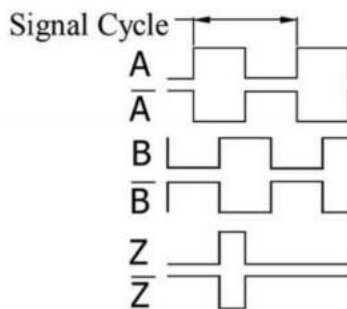

## 1. TECHNICAL PARAMETER

1.1 SCALING DISTANCE: 0.02 MM (50LINES /MM)

1.2 RESOLUTION: 5 $\mu$ M、1 $\mu$ M、0.5 $\mu$ M1.3 PRECISION:  $\pm 3\mu$ M、 $\pm 5\mu$ M、 $\pm 15\mu$ M/M (20 $\pm$ 0.1°C)

1.4 MEASURING RANGE: 30~3000MM

1.5 MOVING SPEED: HIGH-SPEED ENCODER 120 M/MIN (TO BE CUSTOMIZED)

ORDINARY ENCODER 60M/MIN

1.6 POWER SUPPLY: +5V $\pm$ 5%、80MA

1.7 CABLE LENGTH: STANDARD 3M (SPECIAL LENGTH AVAILABLE ACCORDING TO THE USER'S NEEDS)☒

1.8 WORKING TEMPERATURE: 0~45°C

1.9 PIN DESCRIPTION:

1) APPLICABLE TO: 9 PIN SOCKET EIA-422-A SIGNAL OUTPUT.

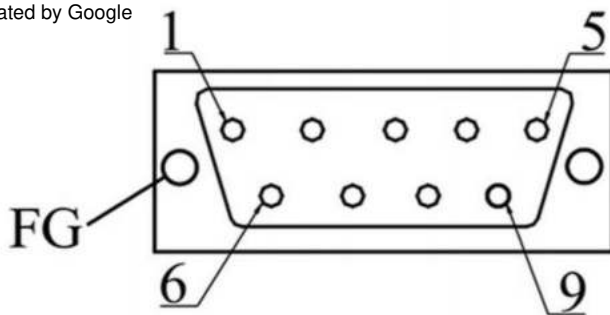

1) Applicable to: 9 pin socket EIA-422-A signal Output.

Pin Position	1	2	3	4	5	6	7	8	9
Signal	$\bar{A}$	$OV$	$\bar{B}$	Empty	$\bar{Z}$	$A$	+5V	$B$	$Z$
Color	Green Black	Black	Orange black	FG	White black	Green	Red	White	Orange

FG: Shield connected to metal casing.

1) Applicable to: 9 pin socket TTL signal Output.

Pin Position	1	2	3	4	5	6	7	8	9
Signal		$OV$		Empty		$A$	+5V	$B$	$Z$
Color		Black		FG		Green	Red	Orange	White

FG: Shield connected to metal casing.

# Lineare Skala

## Einbauzeichnungen

# Installationsmethode:

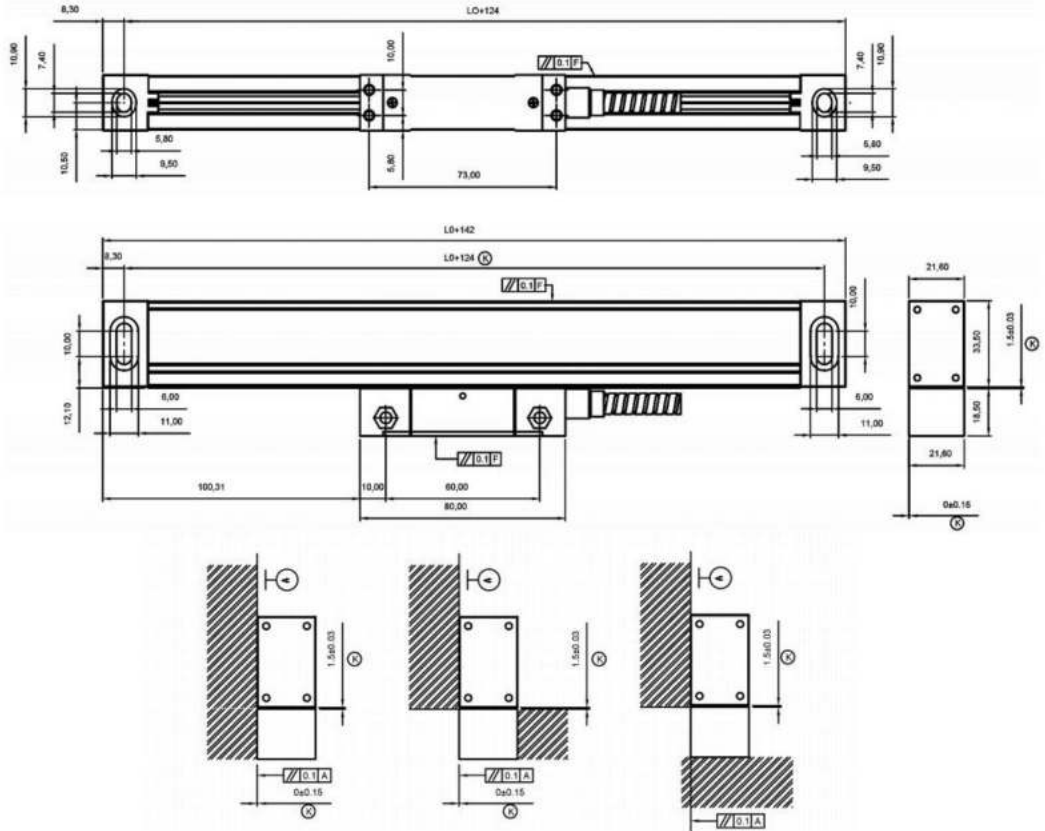

Standardgröße: (Einheit: mm)

Modell	ES	L1	L2	Modell	L0	L1	L2
YE-50	50	174	190	YE-550 550		674	690
YE-100	100	224	240	YE-600	600	724	740
YE-150	150	274	290	YE-650 650		774	790
YE-200 200		324	340	YE-700 700		824	840
YE-250 250		374	390	YE-750	750	874	890
YE-300 300		424	440	YE-800	800	924	940
YE-350 350		474	490	YE-850 850		974	990
YE-400 400		524	540	YE-900	900	1024	1040
YE-450 450		574	590	YE-950 950		1074	1090
YE-500 500		624	640	YE-1000 1000		1124	1140

L0: Effektive Messlänge des Linearenoders; L1: Länge des Linearenoders  
Befestigungslöcher; L2: Gesamtlänge des Linearenoders

## Wartung:

1. Der effektive Weg des Linearencoders sollte länger sein als der maximale Verfahrweg der Werkzeugmaschine. Wenn die Länge nicht ausreicht, ersetzen Sie den Lineargeber durch einen mit größerem Hub oder fügen Sie einen Begrenzungsblock an den Maschinen hinzu. Die Endposition des Lesekopfs vom Ende des Lineargeberkörpers sollte mindestens 10 mm Abstand betragen (siehe folgendes Diagramm).

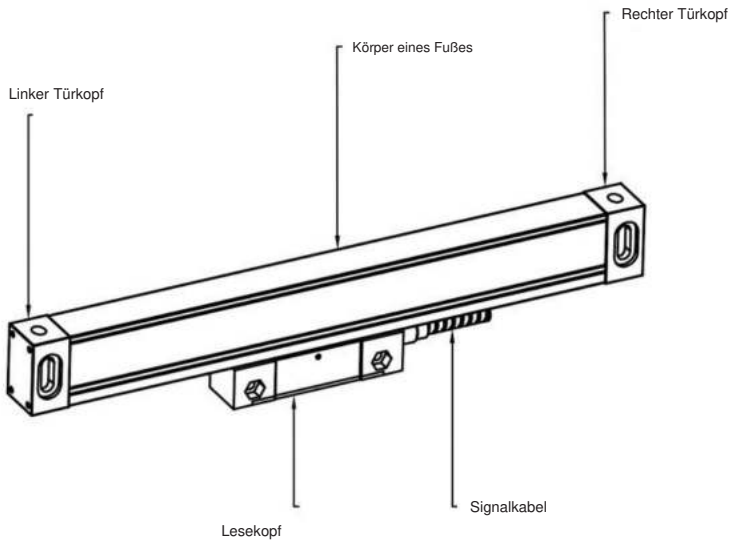

2. Bei jeder nicht bearbeiteten Oberfläche muss auf der Rückseite des Linearencoders eine Unterlegscheibe platziert oder eine benutzerdefinierte Installationsunterlegscheibe verwendet werden, um die Stabilität und Zuverlässigkeit der Verbindung zwischen dem Gitterlineal und der Montagefläche sicherzustellen.
3. Wenn Sie zum Kalibrieren der Parallelität des Linearencoders eine Messuhr oder ein ähnliches Instrument verwenden, muss der Winkel des Seitenkopfes innerhalb von  $\pm 30$  Grad liegen. Je kleiner der Winkel, desto besser.

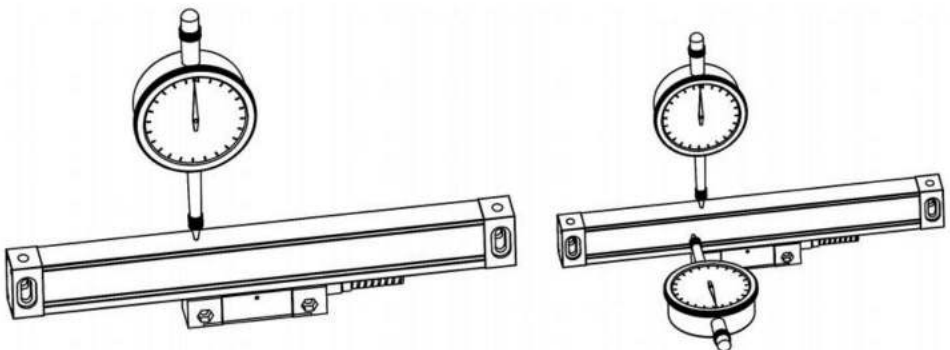

4. Die Einbaulage des Linearencoders muss direkte Stöße durch Eisen vermeiden Späne, Öl, Wasser und Staub (siehe Abbildung unten). Die Einbaulänge der L-Platte sollte unter Umständen so kurz wie möglich sein und die Kräfteverhältnisse des Anschraubgrundes müssen berücksichtigt werden.

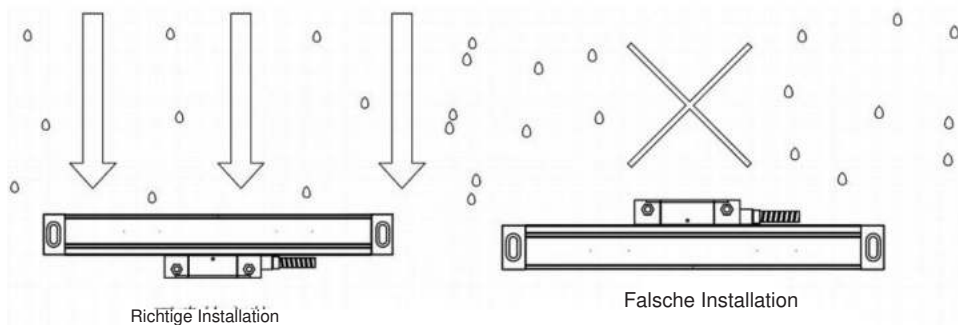

5. Zwischen der Staubschutzhülle und dem Lineal muss ein Abstand von 0,5 mm oder mehr vorhanden sein Körper, und vermeiden Sie den Kontakt zwischen der Staubschutzhülle und dem Linealkörper, wenn Bewegungen des Lesekopfes (siehe unten).

6. Die Gewindetiefe der Installationsschraube muss mindestens 6 Zähne betragen.

Kraft größer Teil, wie die Unterstützung der Digitalanzeige Meter Regal feste Platte, muss 8 Zähne der Verriegelungstiefe haben; YE Serie von Skala, die Tiefe des Gewindes

Tiefe der Verriegelungstiefe. Wie die Unterstützung der Digitalanzeige Meter Regal fixiert

Platte, muss mehr als 8 Zähne Verriegelungstiefe haben; YE Serie Skala Mit M4 Schrauben

Gewindeschneiden der installierten Montagefläche nach dem Entgraten der Oberfläche sowie Entfernen von Farbe und Flecken.

(Die folgende Abbildung)

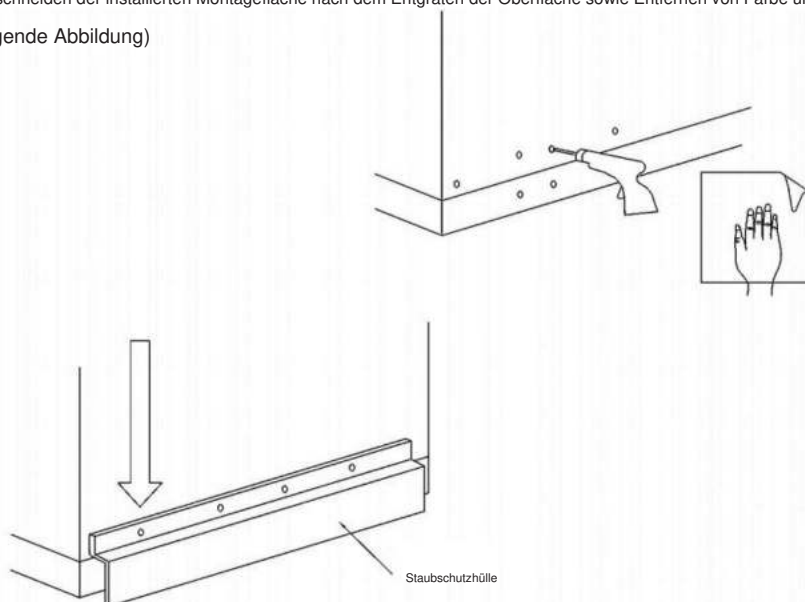

- Bei der Befestigung der Signalleitung müssen alle relevanten Bewegungsdistanzen berücksichtigt werden. Die Befestigungsstelle wird möglichst in der Mitte des Hubes platziert und die überschüssige Signalleitung mit einem Kabelbinder fixiert.
- Die Höheneinstellung der Skala muss so erfolgen, dass die Länge der Skalenmitte die Symmetriepunkte auf beiden Seiten erreicht. Stellen Sie den Referenzpunkt ein. Bei jeder Skala gilt unabhängig von der Höhen- oder Höhenrichtung der Einstellbereich: Für den Skalenkörper gilt ein Abstand von nicht mehr als 20 mm von jedem Ende zum Skalenkopf. Für den Lesekopf gilt zwischen den beiden viereckigen Referenzflächen (siehe folgende Abbildung).

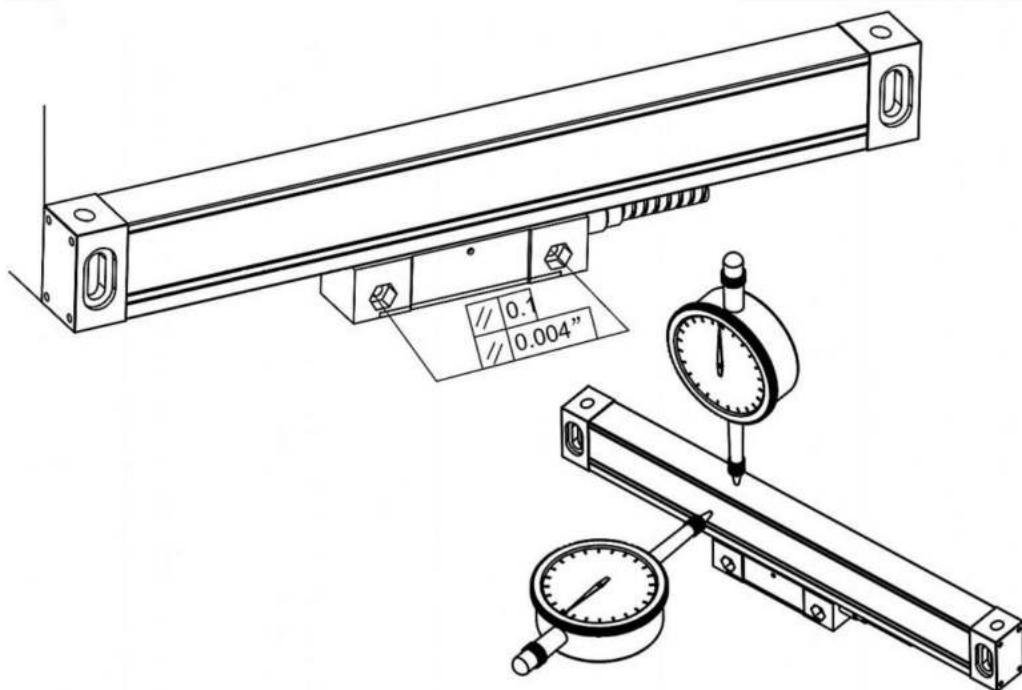

- Der Biegeradius der Signalleitung der Skala ist größer als 60 mm.

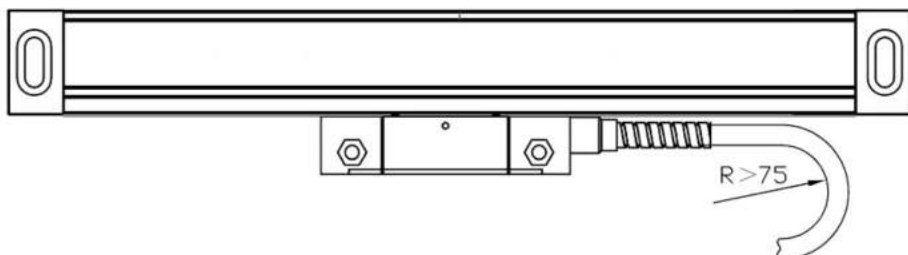

(1) Standard-Installationsgrundfläche (Abbildung 4.8abc, drei Installationsmethoden)

1. Die Installationsfläche des Linealkörpers ist parallel zur Installationsfläche des Lesekopfes und die Parallelität zwischen den Installationsflächen beträgt  $<0,1 \text{ mm}$
2. Die Installationsfläche des Linealkörpers ist senkrecht zur Installationsfläche des Lesekopfes und die Rechtwinkligkeit zwischen den Montageflächen beträgt  $<0,1 \text{ mm}$

2) Standards für die Installation des Linealkörpers (Abbildung 4.9, Abbildung 4.10)

1. Höhenrichtung relativ zur Maschinenführung Parallelität  $<0,1 \text{ mm}$ , maximal nicht mehr als  $0,15 \text{ mm}$ . In Bezug auf den Symmetriepunkt gilt: je kleiner, desto besser.

3) Standard für die Installation des Lesekopfes

1. Der Abstand zwischen dem Lesekopf und der Höhenrichtung des Linealkörpers beträgt nach der Installation  $0,8\text{--}1,6 \text{ mm}$ . Ziehen Sie anschließend den Polsterblock heraus (Abbildung 4.11).

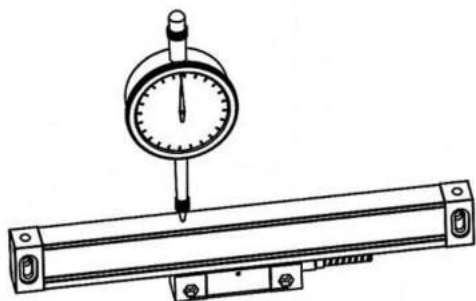

4.9

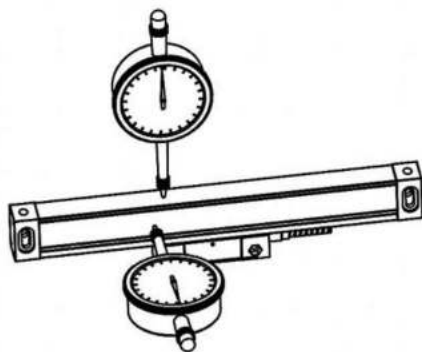

4.10

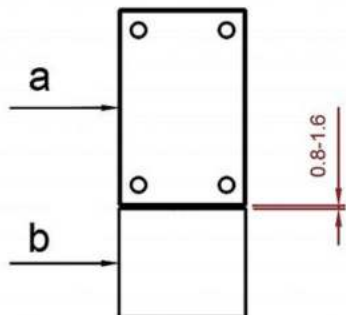

2. Lesekopf Seite A und Linealkörper Seite B.  
Fehlausrichtung in horizontaler Richtung.  
 $0,25 \pm 0,15 \text{ mm}$

3. Parallelität des Lesekopfes zur

Werkzeugmaschine  $<0,10 \text{ mm}$ , maximal darf  $0,30 \text{ mm}$  nicht überschritten werden

**Parameter:**

<b>Model</b>	SNS-3V-YE102024	SNS-3V-YE161838
<b>Rated voltage:</b>	AC85-230V 50Hz/60Hz	
<b>Resolution</b>	5 $\mu$ m	
<b>Number of axes</b>	3	
<b>Range</b>	10 inches 20 inches 24 inches	16 inches 18 inches 38 inches

**Standardzubehör:**

<b>Accessories for digital display meters:</b>	<b>Accessories for grating ruler:</b>
<ol style="list-style-type: none"> <li>1. Support rod * 1</li> <li>2. Knife holder plate * 1</li> <li>3. Transparent watch case * 1</li> <li>4. Power cord * 1</li> <li>5. Watch holder * 1</li> <li>6. Butterfly piece * 2</li> <li>7. M8 * 70 screw * 1</li> <li>8. M10 * 55 screw * 1</li> <li>9. Nut M10 * 1</li> <li>10. Nut M8 * 1</li> <li>11. Nut M5 * 1</li> <li>12. Internal hexagonal screw M5 * 20 * 2</li> <li>13. Internal hexagonal screw M5 * 25 * 1</li> <li>14. M4 * hex socket screw * 4</li> <li>15. M5 * 10 machine meter screws * 2</li> <li>16. Washer <math>\phi</math> 10 * 1</li> <li>17. Washer <math>\phi</math> 8 * 1</li> <li>18. Washer <math>\phi</math> 5 * 1</li> <li>19. Rubber washer 20 * 10 * 1 * 1</li> <li>20. Rubber washer 20 * 10 * 0.5 * 1</li> <li>21. Spring washer <math>\phi</math> 10 * 1</li> <li>22. Spring washer <math>\phi</math> 8 * 1</li> <li>23. Spring washer <math>\phi</math> 5 * 1</li> </ol>	<ol style="list-style-type: none"> <li>1. Ruler cover * 3</li> <li>2. L mounting plate * 4</li> <li>3. Plug * 6</li> <li>4. Screw pack * 3 bags</li> </ol> <p>Each bag contains:</p> <p>Internal hexagonal screw M4 * 30 * 4;  Internal hexagonal screw M4 * 12 * 2;  Internal hexagonal screw M4 * 8 * 4;  U-shaped gasket T=0.2mm * 2;  Washer <math>\phi</math> 6 * 2;  Washer <math>\phi</math> 5 * 2;  Washer <math>\phi</math> 4 * 6;  Line card * 2</p>

Dieses Gerät entspricht Teil 15 der FCC-Bestimmungen. Der Betrieb unterliegt den folgenden beiden Bedingungen: (1) Dieses Gerät darf keine schädlichen Störungen verursachen und (2) dieses Gerät muss alle empfangenen Störungen akzeptieren, einschließlich Störungen, die einen unerwünschten Betrieb verursachen können.

**Hersteller:** Shanghaimuxinmuyeyouxiangongsi

**Adresse:** Shuangchenglu 803nong11hao1602A-1609shi, baoshanqu,  
Shanghai 200000 CN.

**Nach AUS importiert:** SIHAO PTY LTD, 1 ROKEVA STREETEASTWOOD NSW  
2122 Australien

**Importiert in die USA:** Sanven Technology Ltd., Suite 250, 9166 Anaheim Place,  
Rancho Cucamonga, CA 91730



E-CrossStu GmbH

Mainzer Landstr.69, 60329 Frankfurt am Main.



YH CONSULTING LIMITED.

C/O YH Consulting Limited Office 147, Centurion House,  
London Road, Staines-upon-Thames, Surrey, TW18 4AX

**VEVOR**<sup>®</sup>  
TOUGH TOOLS, HALF PRICE

Technischer Support und E-Garantie-Zertifikat  
[www.vevor.com/support](http://www.vevor.com/support)

# VEVOR<sup>®</sup>

## TOUGH TOOLS, HALF PRICE

Supporto tecnico e certificato di garanzia elettronica

[www.vevor.com/support](http://www.vevor.com/support)

## MANUALE D'USO DEL DISPLAY DRO

MODELLO: SNS-3V-YE102024 È NS-3V-YE161838

continuiamo a impegnarci per fornirvi strumenti a prezzi competitivi.

"salva la metà", "Metà prezzo" o qualsiasi altra espressione simile da noi utilizzata rappresenta solo un stima del risparmio che potresti ottenere acquistando determinati strumenti con noi rispetto ai principali marchi top e non significa necessariamente coprire tutte le categorie di strumenti da noi offerti.

ti ricordiamo cortesemente di verificare attentamente quando effettui un ordine con noi se sei risparmiando effettivamente la metà rispetto ai marchi più importanti.

**VEVOR**<sup>®</sup>  
TOUGH TOOLS, HALF PRICE

DISPLAY DRO

MODELLO: SNS-3V-YE102024 SNS-3V-YE161838



HAI BISOGNO DI AIUTO? CONTATTACI!!

Hai domande sul prodotto? Hai bisogno di supporto tecnico? Non esitare a contattarci contattaci:

Supporto tecnico e certificato di garanzia elettronica  
[www.vevor.com/support](http://www.vevor.com/support)

Questa è l'istruzione originale, si prega di leggere tutte le istruzioni del manuale attentamente prima di operare. VEVOR si riserva una chiara interpretazione del nostro manuale utente. L'aspetto del prodotto sarà soggetto alla prodotto ricevuto. Ti preghiamo di scusarci se non ti informeremo più se ci saranno aggiornamenti tecnologici o software sul nostro prodotto.

Cari utenti:

Grazie per aver acquistato i display digitali multifunzione della serie ·

Le letture digitali sono utilizzate in un'ampia gamma di applicazioni. Tra queste: macchine utensili , negli assi di alimentazione, apparecchiature di misurazione e controllo, EDM e stazioni apparecchi di divisione, utensili di regolazione , di misurazione per controllo della produzione. Per soddisfare i requisiti di questi applicazioni, molti encoder possono essere collegati ai display digitali. Leggere attentamente tutte le istruzioni nel manuale prima dell'uso e seguirli rigorosamente · conservare il manuale per riferimenti futuri ·

attenzione alla sicurezza:

- ⌘ PER prevenire scosse elettriche o incendi, umidità o spruzzi diretti liquido di raffreddamento deve essere evitato. In caso di fumo o particolari odore dal display digitale, si prega di scollegare la spina di alimentazione immediatamente, altrimenti potrebbero verificarsi incendi o scosse elettriche. in tal caso, non tentare di ripararlo, contattare l'azienda o **distributors.**
- ⌘ Il display digitale è un dispositivo di misurazione preciso utilizzato con un'ottica Scala lineare · quando è in uso, se la connessione tra il La scala lineare e la lettura digitale sono rotte o danneggiate esternamente, possono essere rilevati valori di misurazione errati · Pertanto, l'utente deve fare attenzione.
- ⌘ Non tentare di riparare o modificare il display digitale, altrimenti si verificherà un guasto, potrebbe verificarsi un guasto o un infortunio. In caso di qualsiasi condizione anomala, contattare l'azienda o il distributore.
- ⌘ Se la scala lineare ottica utilizzata con la lettura digitale è danneggiata, non utilizzare una scala lineare di un'altra marca. Poiché le prestazioni, le specifiche e la connessione dei prodotti di marche diverse possono variare non essere collegato senza l'istruzione di un tecnico specializzato personale, altrimenti si verificheranno dei problemi al display digitale.
- ⌘ **With the continuous updating of products, if there are changes or** modifiche ai parametri del campione, prevarranno i file casuali e la società avrà il diritto di interpretazione finale senza preavviso.

## Contents

---

1.	Illustration of Panel and keyboard .....	4
2.	Caption of the keyboard .....	5
3.	Parameters settings .....	7
3.1	Parameters setup routine entrance .....	7
3.2	Parameters Settings Description .....	7
3.2.1	Setting the Resolution .....	7
3.2.2	Setting Positive Direction for Counter .....	8
3.2.3	Toggle Between R/D Display Mode .....	8
3.2.4	Setting Z axis Dial .....	8
3.2.5	Setting the Rotary Radius of the Workpiece.....	9
3.2.6	Setting the Angle Display Mode .....	9
3.2.7	Setting the Baudrate of RS_232(optional) .....	9
3.2.8	Setting the Absolute Zeroing enable or disable .....	10
3.2.9	Setting the Absolute form the Special Function .....	10
3.2.10	Setting the Calculator display Mode.....	10
3.2.11	display brightness setting .....	10
3.2.12	The linear scale counting frequency setting .....	11
3.2.13	Setting QUIT .....	11
3.2.14	Setting the type of the DRO. ....	11
3.2.15	Signal Interface Type .....	11
3.2.16	Restore Factory Settings: .....	12
3.2.17	Shrinkage Ratio enable or disable.....	12
3.2.18	Setting Compensation Type .....	12
3.2.19	Inch display, set the number of digits after the decimal point...	13
3.2.20	Setting EDM(optional) .....	13
3.2.21	Setting Linearity Compensation. ....	13
3.2.22	Setting the Shrinkage Ratio .....	13
4.	General Operations .....	14
4.1	Zeroing.....	14
4.2	Preset Data to Designated Axis .....	14
4.3	Toggle Display Unit between inch and mm .....	14
4.4	Absolute/Incremental/200 groups SDM .....	15
4.5	1/2 Function .....	15
4.6	Clear All SDM Datum.....	16

## Contents

---

4.7 Sleeping Mode .....	16
4.8 Power Interruption Memory .....	16
4.9 Search the Absolute Reference Point of Scale .....	17
4.10 Non Linear Error Compensation .....	20
5、200 Groups SDM coordinate .....	21
5.1 Zeroing at the Current Point.....	21
5.2 Preset datum of SDM coordinate .....	22
6、Special Function.....	24
6.1 Circumference Holes Processing .....	25
6.2 Linear Holes Processing .....	28
6.3 ARC Processing .....	30
6.4 Oblique Processing .....	39
6.5 Slope Processng.....	43
6.6 Chamber Processing.....	44
6.7 The Tool Diameter Compensation Function .....	45
6.8 Digital Filter of the Grinding Machine .....	46
6.9 Lathe Function .....	47
6.9.1 200 sets TOOL Libs .....	47
6.9.2 Taper Function .....	48
6.9.3 R/D Function .....	49
6.9.4 Y + Z Function ( only applicable to : 3 axes Lathe).....	49
6.10 EDM.....	50
7、Calculator.....	56
8、Appendix .....	57

## Illustration of Panel and keyboard

## THREE AXIS PANEL

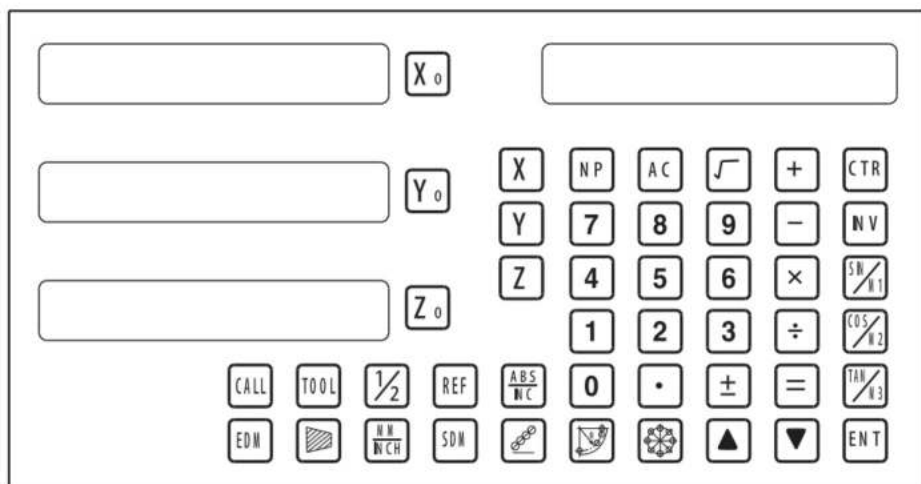



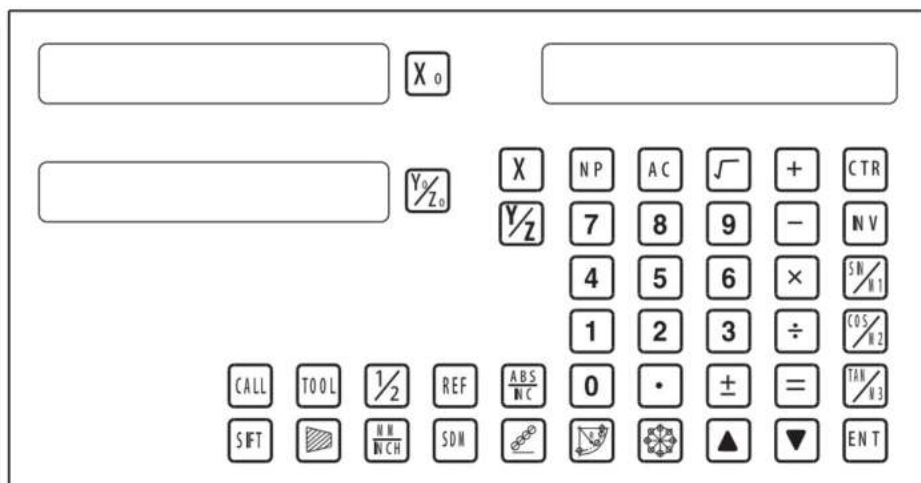









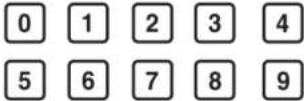



## TWO AXIS PANEL















## Caption of the keyboard

## Keyboard Description

	Keys for axis selection
	Zero select axis
	Enter +/- sign
	Enter decimal point
	Entry keys for numbers
	Operation key (in Calculation function key)
	Enter or quit calculating state
	Cancel incorrect operation
	Calculate inverse trigonometric
	Square root
	Confirm operation
	Toggles between inch and millimeter units.
	Press when ready to identify a reference mark.
	Function keys for 200 sub datum
	ARC cutting function
	holes displayed equally on a circle
	holes displayed equally on a line

## Caption of the keyboard



	Calculate trigonometric or Slope Processing function key
	Calculate trigonometric or rectangular inner chamber processing function key
	Calculate trigonometric or the tool diameter compensation function key
	Toggle between ABS/INC coordinate
	Stroll up or down to select
	Taper measured function key
	Tool library call key
	Opens the tool table.( lathe)
	EDM function key
	Filter display function key
	Half a display value of an axis
	Non Linear Error Compensation function keys





## Parameters settings

---

### 3. Parameters settings

#### 3.1 Parameters setup routine entrance.

Press  to enter initial system and self-check after DRO powers on in 1 second, then Parameters settings display in the Parameters window. Press   to select the item you want to change.

If you want to quit initial setting, press   until "QUIT" appears in message window and press . You can also press  to quit initial setting.

#### 3.2 Parameters Settings Description



##### 3.2.1 Setting the Resolution

Press   until "RESOLUTE" appears in message window;

When selecting the LINEAR encode, the resolution will be set as follow:

There are 19 types of resolution:

0.01um;0.02um;0.05um;0.10um;0.20um;0.25um;0.50um;1.00um;  
2.00um;2.50um;5.00um;10.00um;20.00um;25.00um;50.00um;  
100.00um;200.00um;250.00um;500.00um.

Press  to change the resolution for X axis; Press  to change the resolution for Y axis; Press  to change the resolution for Z axis;

Set the resolution 5.00um to 1.00um for X axis:

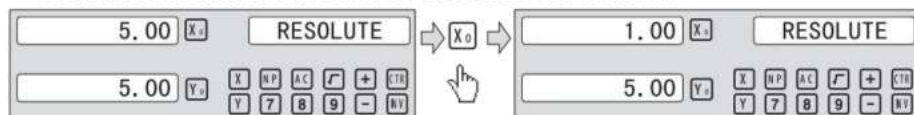

When selecting the rotary encode, the resolution will be set as follow:

Input the rotary encode parameter value .

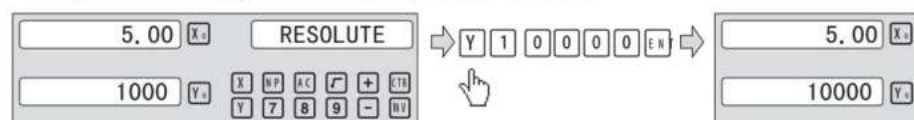

## Parameters settings

---

### 3.2.2 Setting Positive Direction for Counter

Press **▲** **▼** until “DIRECTE” appears in message window.

Direction ‘0’ means the display value will increase when scale moves from right to left and decrease when scale moves from left to right. Direction ‘1’ means the display value will increase when scale moves from left to right and decrease when scale moves from right to left.

Press **X0** to change the Direction for X axis; Press **Y0** to change the Direction for Y axis; Press **Z0** to change the Direction for Z axis; as follow:

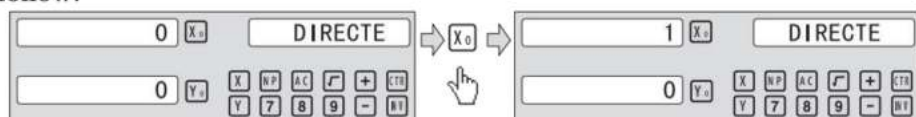

### 3.2.3 Toggle Between R/D Display Mode

Press **▲** **▼** until “R OR D” appears in message window. X window, Y window, Z window displays ‘0’ or ‘1’ separately.

‘0’ is mode R, which means the display value equals the actual measurement. ‘1’ is mode D where the display value equals the double actual measurement. Press **X0** to change the R/D for X axis; Press **Y0** to change the R/D for Y axis; Press **Z0** to change the R/D for Z axis; as follow:

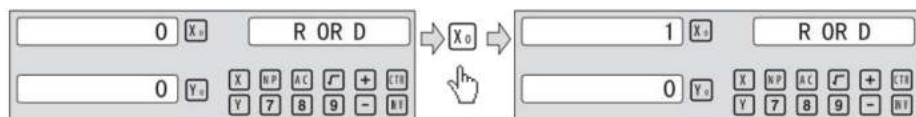

### 3.2.4 Setting Z axis Dial

Press **▲** **▼** until “Z DIAL” appears in message window.

Z axis dial should be set if Z axis is emulated for 2 axis milling and only install linear scale for X,Y axis. Z axis dial means the distance the Z axis travels when screw runs a revolution.

## Parameters settings

Set the Z axis Dial 2.5mm as follow ;



### 3.2.5 Setting the Rotary Radius of the Workpiece

Press **▲** **▼** until “RDIUS” appears in message window.

The Rotary radius type is used perimeter to measure angle.

Input the Rotary Radius parameter value 2000mm as follow:

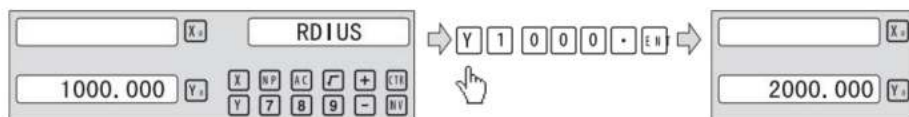

### 3.2.6 Setting the Angle Display Mode

Press **▲** **▼** until “ANG DISP” appears in message window.

Press **X<sub>0</sub>** to change the angle display mode for X axis; Press **Y<sub>0</sub>** to change the angle display mode for Y axis; Press **Z<sub>0</sub>** to change the angle display mode for Z axis; Example for X axis:

“0.0000” means the angle mode is Circulating DD;

“0000.0000” means the angle mode is Incremental DD;

“0.00.00” means the angle mode is Circulating DMS;

“0000.00.00” means the angle mode is Incremental DMS;

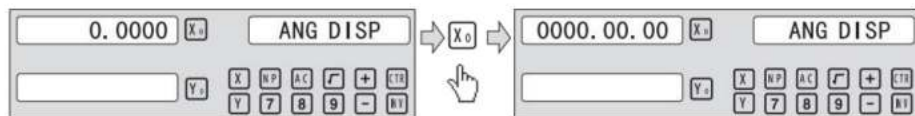



### 3.2.7 Setting the Baudrate of RS\_232 (Special customization function, if you need to buy, please contact the dealer to customize)

Press **▲** **▼** until “BAUDRATE” appears in message window.

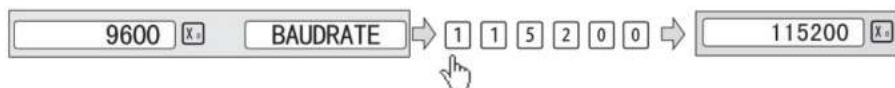
Set the Baudrate 115200 as follow ;





## 3.2.8 impostazione abilita o disabilita l'azzeramento assoluto

premere   affinché non compare "ABS ZERO" nella finestra dei messaggi.

IL significa che l'operazione di azzeramento ABS e i dati preimpostati saranno abilitare nello stato di visualizzazione normale.

' 1 ' significa che l'operazione di azzeramento ABS e i dati preimpostati saranno disabilitare nello stato di visualizzazione normale.



premere  per cambiare la modalità di azzeramento assoluto per l'asse x, premere

 per cambiare la modalità di azzeramento assoluto per l'asse Y, premere  A

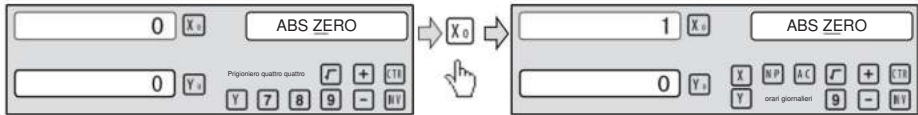
cambia la modalità di azzeramento assoluto per l'asse Z; Esempio per l'asse x .



## 3.2.9 impostazione della forma assoluta della funzione speciale

premere   affinché non compare "ABS ASST" nella finestra dei messaggi.



'o significa che solo il valore della posizione della funzione speciale viene visualizzato nell'operazione di funzione speciale.

' 1 ' significa valore di posizione della funzione speciale + valore di posizione ABS è visualizzare nell'operazione Funzione speciale.

premere  per cambiare la modalità assoluta per la funzione speciale

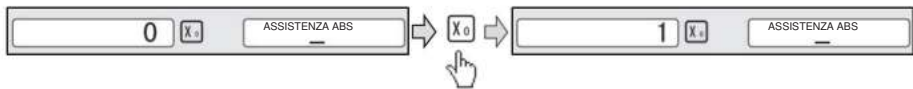
essere impostato come segue:

3.2.10 impostazione del **Calculator** Modalità di visualizzazione

premere   affinché nel messaggio W non compare "UCCTR MODE" **indow**

IL **calculator** visualizza il valore in corrispondenza del vento x nel **disply**;

' 1 ' **calcolatrice** visualizza il valore nella finestra dei messaggi nel **disply**;

premere  per cambiare la modalità di visualizzazione della calcolatrice verrà impostata AS **follow**

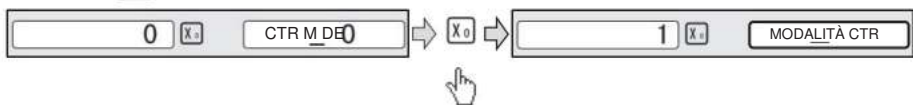

## 3.2.11 impostazione della luminosità del display

Impostazione della luminosità del display LED, l'impostazione predefinita di fabbrica è solo "3", più alto è il parametro, più luminosa è la luminosità. premere "xo" per impostato, non è consigliabile impostare autonomamente il valore predefinito.

## Parameters settings

## 3.2.12 The linear scale counting frequency setting

The factory default setting is only "12", the higher the parameter, the lower the counting frequency, press "X0" to set, it is not recommended that you set the default value yourself.

## 3.2.13 Setting QUIT: Digital display table parameters quit button.

## 3.2.14 Setting the type of the DRO.

The type of the DRO will be display on the right window. then press the key **ENT** to select the correct type. the following system item will be set:

"MILL-3" means the DRO type is 3-axis milling machine table;

"MILL-2" means the DRO type is 2-axis milling machine table;

"LATHE-2" means the DRO type is 2-axis lathe table;

"LATHE-3" means the DRO type is 3-axis lathe table;

"GRIND" means the DRO type is Grind table;

"EDM" means the DRO type is EDM table; (Special customization function, if you need to buy, please contact the dealer to customize)

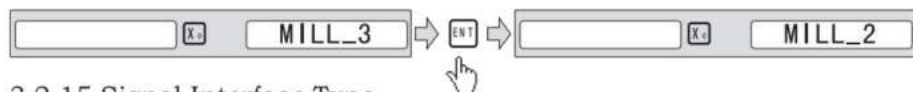

## 3.2.15 Signal Interface Type

Message window displays "SEL AXIS" which indicates the step is to Sensor input signal mode. Press **X0** to change the signal mode for X axis; Press **Y0** to change the signal mode for Y axis; Press **Z0** to change the signal mode for Z axis; Example for X axis:

Press **X0** to scroll through the Rotary encode type, the Linear encode type, the Rotary rdius type.

X window displays the Signal type.

"LInER" means the Signal type is linear encode type ;

"EnCoDE " means the Signal type is Rotary encode type;

"RdIUS" means the Signal type is Rotary rdius type ;

Example: currently in the linear encode type, to toggle to the Rotary encode type;

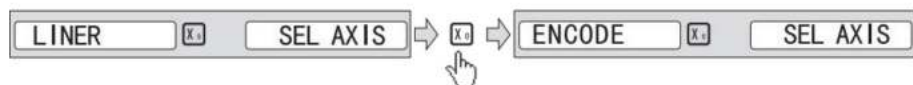

## Parameters settings

## 3.2.16 Restore Factory Settings:

Clear all data except DRO type. DRO will load default setup for parameter. After loading default setup, user must search RI once to enable resuming ABS datum function; otherwise to resume the datum by RI is unable;

Message window displays “ALL CLR”, press **ENT** and message windows display “PASSWORD” indicating the operator to input password; Press 2000 + **ENT** in turn to load default value;

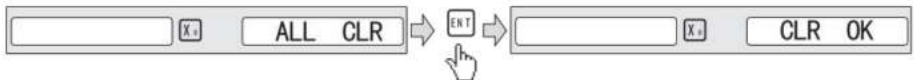

## 3.2.17 Shrinkage Ratio enable or disable.

Message window displays “SRK OFF” to disable Shrinkage rate function. Press **ENT** to enable Shrinkage rate function in Message window displays “SRK ON” :

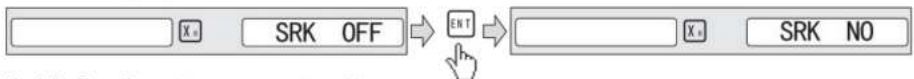

## 3.2.18 Setting Compensation Type

Message window displays “SEL COMP” which indicates the step is to compensation type. Press **X0** to change the compensation type for X axis; Press **Y0** to change the compensation type for Y axis; Press **Z0** to change the compensation type for Z axis; Example for X axis:

Press **X0** to scroll through the not compensation type, the Linear compensation type, the non-linear compensation type.

“no-CO” means the compensation type is not compensation type;

“LinE-CO” means the compensation type is linear compensation type.

“non-LinE” means the compensation type is non-linear linear compensation type;

Example for X axis: currently in the not compensation type, to toggle to the linear compensation type;

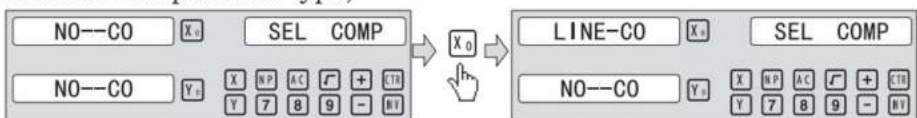

## Parameters settings

## 3.2.19 Inch display, set the number of digits after the decimal point

In the inch display mode, the number of digits after the decimal point is set, the factory default digit is "4", press "X0" to set, can be set according to actual needs.

3.2.20 Setting EDM: it is not recommended that you set the default value yourself, EDM function, Set the relay off on time.

## 3.2.21 Setting Linearity Compensation.

Message window displays "LIN COMP" which indicates the step is to Linearity Compensation. Compensate the linear error to make display value equals to standard value.

The calculation of compensation rectifying coefficient:

$$\text{Coefficient} = \frac{(\text{Measurement} - \text{Standard value}) \times 1000.000}{\text{Standard value}}$$

Example for X axis:

Measurement 200.020mm

Standard value 200.000mm

Rectifying coefficient= (200.020-200) \* 1000 /200 =-0.01mm/m

Input compensation rectifying coefficient 0.01 as follow:

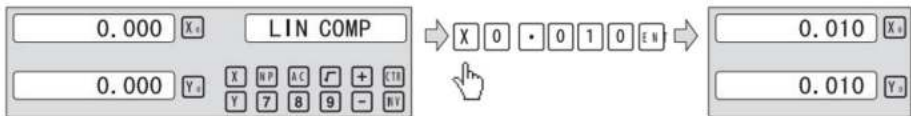

## 3.2.22 Setting the Shrinkage Ratio

Press until "SHRINK" appears in message window;

$$\text{Shrinkage ratio} = \frac{\text{Dimensions of the finished product}}{\text{Dimensions of the working piece}}$$

Set the shrinkage ratio 1.005 as follow;

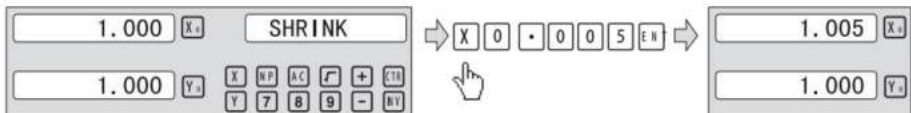







## General Operations

---

### 4、 General Operations;

#### 4.1 Zeroing



Zero the designated axis in normal display state. Zeroing is used to set the current position as datum point as follow;

key		<span style="border: 1px solid black; padding: 2px;">X<sub>0</sub></span>		X axis zero	<table style="width: 100%; border-collapse: collapse;"> <tr> <td style="width: 80%; border: 1px solid gray; padding: 2px;">0.000</td> <td style="width: 20%; border: 1px solid gray; padding: 2px;"><span style="border: 1px solid black; padding: 2px;">X<sub>0</sub></span></td> </tr> <tr> <td style="border: 1px solid gray; padding: 2px;">0.000</td> <td style="border: 1px solid gray; padding: 2px;"><span style="border: 1px solid black; padding: 2px;">Y<sub>0</sub></span></td> </tr> <tr> <td style="border: 1px solid gray; padding: 2px;">0.000</td> <td style="border: 1px solid gray; padding: 2px;"><span style="border: 1px solid black; padding: 2px;">Z<sub>0</sub></span></td> </tr> </table>	0.000	<span style="border: 1px solid black; padding: 2px;">X<sub>0</sub></span>	0.000	<span style="border: 1px solid black; padding: 2px;">Y<sub>0</sub></span>	0.000	<span style="border: 1px solid black; padding: 2px;">Z<sub>0</sub></span>
0.000	<span style="border: 1px solid black; padding: 2px;">X<sub>0</sub></span>										
0.000	<span style="border: 1px solid black; padding: 2px;">Y<sub>0</sub></span>										
0.000	<span style="border: 1px solid black; padding: 2px;">Z<sub>0</sub></span>										
key		<span style="border: 1px solid black; padding: 2px;">Y<sub>0</sub></span>		Y axis zero							
key		<span style="border: 1px solid black; padding: 2px;">Z<sub>0</sub></span>		Z axis zero							

X<sub>0</sub> or Y<sub>0</sub> or Z<sub>0</sub> will be return to the original data before the reset.

#### 4.2 Preset Data to Designated Axis



Preset a value to current position for a designated axis in normal display state.

<table style="width: 100%; border-collapse: collapse;"> <tr><td style="border: 1px solid gray; padding: 2px;">25.400</td><td style="border: 1px solid gray; padding: 2px;"><span style="border: 1px solid black; padding: 2px;">X<sub>0</sub></span></td></tr> <tr><td style="border: 1px solid gray; padding: 2px;">50.800</td><td style="border: 1px solid gray; padding: 2px;"><span style="border: 1px solid black; padding: 2px;">Y<sub>0</sub></span></td></tr> <tr><td style="border: 1px solid gray; padding: 2px;">76.200</td><td style="border: 1px solid gray; padding: 2px;"><span style="border: 1px solid black; padding: 2px;">Z<sub>0</sub></span></td></tr> </table>	25.400	<span style="border: 1px solid black; padding: 2px;">X<sub>0</sub></span>	50.800	<span style="border: 1px solid black; padding: 2px;">Y<sub>0</sub></span>	76.200	<span style="border: 1px solid black; padding: 2px;">Z<sub>0</sub></span>			<table style="width: 100%; border-collapse: collapse;"> <tr><td style="border: 1px solid gray; padding: 2px;">X</td><td style="border: 1px solid gray; padding: 2px;">1</td><td style="border: 1px solid gray; padding: 2px;">8</td><td style="border: 1px solid gray; padding: 2px;">0</td><td style="border: 1px solid gray; padding: 2px;">.</td><td style="border: 1px solid gray; padding: 2px;">0</td><td style="border: 1px solid gray; padding: 2px;">1</td><td style="border: 1px solid gray; padding: 2px;">0</td><td style="border: 1px solid gray; padding: 2px;">ENT</td></tr> </table>	X	1	8	0	.	0	1	0	ENT		<table style="width: 100%; border-collapse: collapse;"> <tr><td style="border: 1px solid gray; padding: 2px;">180.010</td><td style="border: 1px solid gray; padding: 2px;"><span style="border: 1px solid black; padding: 2px;">X<sub>0</sub></span></td></tr> <tr><td style="border: 1px solid gray; padding: 2px;">586.010</td><td style="border: 1px solid gray; padding: 2px;"><span style="border: 1px solid black; padding: 2px;">Y<sub>0</sub></span></td></tr> <tr><td style="border: 1px solid gray; padding: 2px;">888.660</td><td style="border: 1px solid gray; padding: 2px;"><span style="border: 1px solid black; padding: 2px;">Z<sub>0</sub></span></td></tr> </table>	180.010	<span style="border: 1px solid black; padding: 2px;">X<sub>0</sub></span>	586.010	<span style="border: 1px solid black; padding: 2px;">Y<sub>0</sub></span>	888.660	<span style="border: 1px solid black; padding: 2px;">Z<sub>0</sub></span>
25.400	<span style="border: 1px solid black; padding: 2px;">X<sub>0</sub></span>																									
50.800	<span style="border: 1px solid black; padding: 2px;">Y<sub>0</sub></span>																									
76.200	<span style="border: 1px solid black; padding: 2px;">Z<sub>0</sub></span>																									
X	1	8	0	.	0	1	0	ENT																		
180.010	<span style="border: 1px solid black; padding: 2px;">X<sub>0</sub></span>																									
586.010	<span style="border: 1px solid black; padding: 2px;">Y<sub>0</sub></span>																									
888.660	<span style="border: 1px solid black; padding: 2px;">Z<sub>0</sub></span>																									



#### 4.3 Toggle Display Unit between inch and mm

Length can be displayed either in “mm” (metric) or “inch” (imperial). Display unit can be toggled between mm and inch.

Example: Display value toggle from mm to inch;

<table style="width: 100%; border-collapse: collapse;"> <tr><td style="border: 1px solid gray; padding: 2px;">25.400</td><td style="border: 1px solid gray; padding: 2px;"><span style="border: 1px solid black; padding: 2px;">X<sub>0</sub></span></td></tr> <tr><td style="border: 1px solid gray; padding: 2px;">50.800</td><td style="border: 1px solid gray; padding: 2px;"><span style="border: 1px solid black; padding: 2px;">Y<sub>0</sub></span></td></tr> <tr><td style="border: 1px solid gray; padding: 2px;">76.200</td><td style="border: 1px solid gray; padding: 2px;"><span style="border: 1px solid black; padding: 2px;">Z<sub>0</sub></span></td></tr> </table>	25.400	<span style="border: 1px solid black; padding: 2px;">X<sub>0</sub></span>	50.800	<span style="border: 1px solid black; padding: 2px;">Y<sub>0</sub></span>	76.200	<span style="border: 1px solid black; padding: 2px;">Z<sub>0</sub></span>	mm		<span style="border: 1px solid black; padding: 2px;">mm inch</span>		inch	<table style="width: 100%; border-collapse: collapse;"> <tr><td style="border: 1px solid gray; padding: 2px;">1.0000</td><td style="border: 1px solid gray; padding: 2px;"><span style="border: 1px solid black; padding: 2px;">X<sub>0</sub></span></td></tr> <tr><td style="border: 1px solid gray; padding: 2px;">2.0000</td><td style="border: 1px solid gray; padding: 2px;"><span style="border: 1px solid black; padding: 2px;">Y<sub>0</sub></span></td></tr> <tr><td style="border: 1px solid gray; padding: 2px;">3.0000</td><td style="border: 1px solid gray; padding: 2px;"><span style="border: 1px solid black; padding: 2px;">Z<sub>0</sub></span></td></tr> </table>	1.0000	<span style="border: 1px solid black; padding: 2px;">X<sub>0</sub></span>	2.0000	<span style="border: 1px solid black; padding: 2px;">Y<sub>0</sub></span>	3.0000	<span style="border: 1px solid black; padding: 2px;">Z<sub>0</sub></span>
25.400	<span style="border: 1px solid black; padding: 2px;">X<sub>0</sub></span>																	
50.800	<span style="border: 1px solid black; padding: 2px;">Y<sub>0</sub></span>																	
76.200	<span style="border: 1px solid black; padding: 2px;">Z<sub>0</sub></span>																	
1.0000	<span style="border: 1px solid black; padding: 2px;">X<sub>0</sub></span>																	
2.0000	<span style="border: 1px solid black; padding: 2px;">Y<sub>0</sub></span>																	
3.0000	<span style="border: 1px solid black; padding: 2px;">Z<sub>0</sub></span>																	

Example: Display value toggle from inch to mm;

<table style="width: 100%; border-collapse: collapse;"> <tr><td style="border: 1px solid gray; padding: 2px;">1.0000</td><td style="border: 1px solid gray; padding: 2px;"><span style="border: 1px solid black; padding: 2px;">X<sub>0</sub></span></td></tr> <tr><td style="border: 1px solid gray; padding: 2px;">2.0000</td><td style="border: 1px solid gray; padding: 2px;"><span style="border: 1px solid black; padding: 2px;">Y<sub>0</sub></span></td></tr> <tr><td style="border: 1px solid gray; padding: 2px;">3.0000</td><td style="border: 1px solid gray; padding: 2px;"><span style="border: 1px solid black; padding: 2px;">Z<sub>0</sub></span></td></tr> </table>	1.0000	<span style="border: 1px solid black; padding: 2px;">X<sub>0</sub></span>	2.0000	<span style="border: 1px solid black; padding: 2px;">Y<sub>0</sub></span>	3.0000	<span style="border: 1px solid black; padding: 2px;">Z<sub>0</sub></span>	inch		<span style="border: 1px solid black; padding: 2px;">mm inch</span>		mm	<table style="width: 100%; border-collapse: collapse;"> <tr><td style="border: 1px solid gray; padding: 2px;">25.400</td><td style="border: 1px solid gray; padding: 2px;"><span style="border: 1px solid black; padding: 2px;">X<sub>0</sub></span></td></tr> <tr><td style="border: 1px solid gray; padding: 2px;">50.800</td><td style="border: 1px solid gray; padding: 2px;"><span style="border: 1px solid black; padding: 2px;">Y<sub>0</sub></span></td></tr> <tr><td style="border: 1px solid gray; padding: 2px;">76.200</td><td style="border: 1px solid gray; padding: 2px;"><span style="border: 1px solid black; padding: 2px;">Z<sub>0</sub></span></td></tr> </table>	25.400	<span style="border: 1px solid black; padding: 2px;">X<sub>0</sub></span>	50.800	<span style="border: 1px solid black; padding: 2px;">Y<sub>0</sub></span>	76.200	<span style="border: 1px solid black; padding: 2px;">Z<sub>0</sub></span>
1.0000	<span style="border: 1px solid black; padding: 2px;">X<sub>0</sub></span>																	
2.0000	<span style="border: 1px solid black; padding: 2px;">Y<sub>0</sub></span>																	
3.0000	<span style="border: 1px solid black; padding: 2px;">Z<sub>0</sub></span>																	
25.400	<span style="border: 1px solid black; padding: 2px;">X<sub>0</sub></span>																	
50.800	<span style="border: 1px solid black; padding: 2px;">Y<sub>0</sub></span>																	
76.200	<span style="border: 1px solid black; padding: 2px;">Z<sub>0</sub></span>																	

## General Operations

### 4.4 Absolute/Incremental/200 groups SDM

**Function:** The DRO has 3 coordinate display modes: the absolute mode (ABS); the incremental mode (INC) and 200 groups Second Data Memory (SDM) with the range of 00 to 99. Zero point of work-piece is set at the origin point of ABS coordinate. The relative distance between datum of ABS and SDM remains unchanged when ABS datum is changed.

1. Toggle from ABS to INC coordinate;

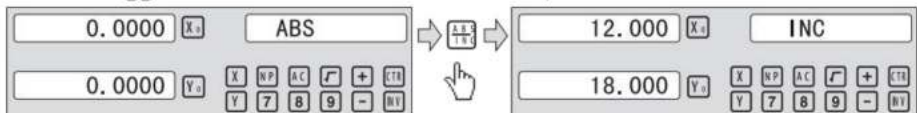

2. Toggle from INC to ABS coordinate;

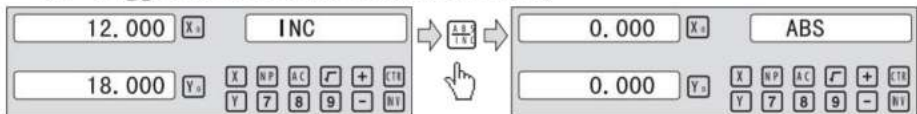

3. Toggle from SMD to ABS coordinate;

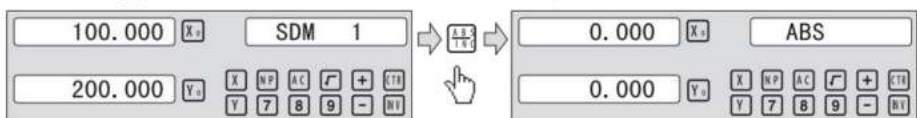

### 4.5 1/2 Function

**Function:** Set the center of work piece as datum by halving the displayed value.

**Example:** Set the center of rectangle as datum as the right figure.

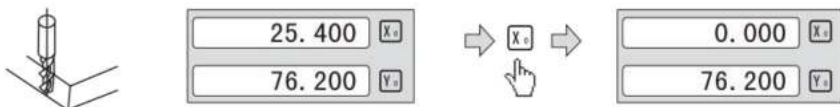

**Steps:**

1. Touch one side of the workpiece with the TOOL, then zero the X axis.



## Operazioni generali

2 , PORTARE L'UTENSILE sul lato opposto del pezzo in lavorazione e toccarlo.

Quindi premere  +  a sua volta per valutare il valore visualizzato sull'asse X.

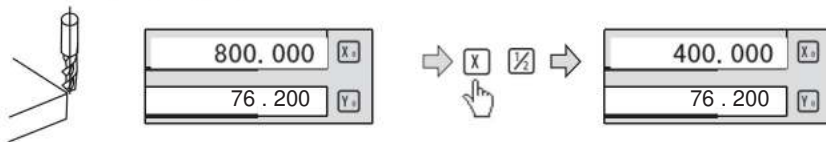

3) Spostare il tavolo di lavorazione finché non viene visualizzato "0.000" sull'asse x finestra. La posizione è il centro del pezzo in lavorazione.

4.6 cancella tutti i dati SDM.

In modalità ABS, premere continuamente  dieci volte causerà la cancellazione tutti i dati per 200 set SDM. La finestra Mcsage visualizza USDM "CLR" .

4.7 Modalità di sospensione

in modalità non ABS, premendo il tasto  CAAn spegne tutti i display

e il DRO accede alla modalità di sospensione, quindi premendo questo tasto di nuovo CAUSE il DRO torna alla modalità di lavoro. Nella modalità di sospensione Modalità il DRO è ancora in stato di funzionamento e registra effettivamente lo **STRUMENTO movement.**

Esempio: in modalità non ABS, per accedere alla modalità sleepin8 premere il tasto F. In modalità di sospensione, premere il tasto F per uscire 

Modalità di sospensione .

4.8 Memoria di interruzione di corrente.

La memoria viene utilizzata per memorizzare le impostazioni del DRO e della macchina valori di riferimento quando POWER è spento.



## General Operations

### Example for REF mode :

1、DRO is set in ABS coordinate. Press **REF**, then the message window display “REF” .

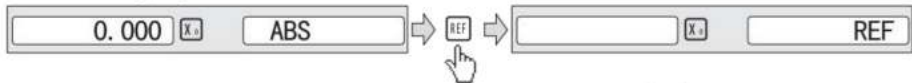

2、Message window displays “REF” , Press **ENT** until “FD\_REF” appears in message window.

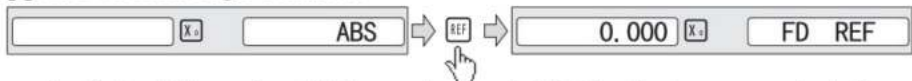

3、Select the axis which need search RI. For instance : select X axis, then press **X** . “X\_REF” is displayed in message window, and X axis window flashes.

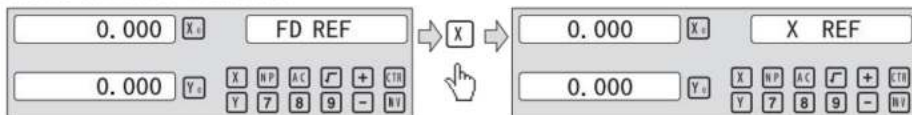

4、Move the machine table .The buzzer sounds when RI is searched, then X window stops flashing and displays the value of the current position .the DRO returns normal display state. Then message window displays “FIND\_X” .

### Example for AB mode :

1、DRO is set in ABS coordinate. Press **REF**, then the message window display “REF” .

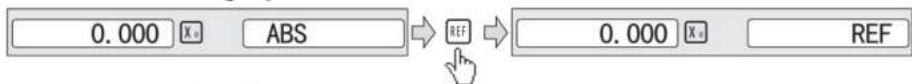

2、Press **▲ ▼**, then the message window display “AB” .

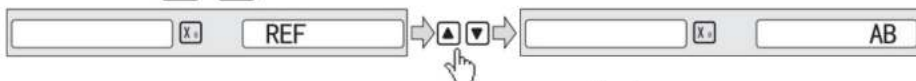

3、Message window displays “AB” , Press **ENT** until “FIND\_AB” appears in message window.

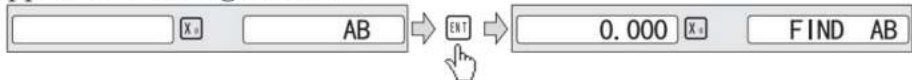

## General Operations

4、 Select the axis which need search RI. For instance : selct X axis, then press **X** . “X\_REF” is displayed in message window, and X axis window flashes.

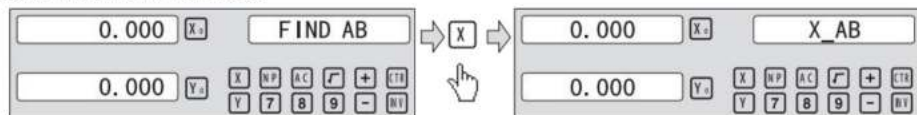

5、 Move the machine table .The buzzer sounds when RI is searched, displays the value of the current position for the absolute datum zero. the DRO returns normal display state. Then message window displays “FIND\_AB” .

### Example for LEF\_AB mode :

1、 DRO is set in ABS coordinate. Press **REF** , then the message window display “REF” .

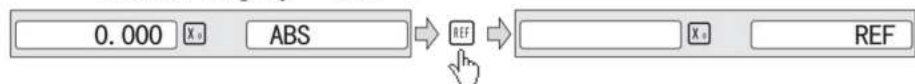

2、 Press **▲** **▼** , then the message window display “AB” .

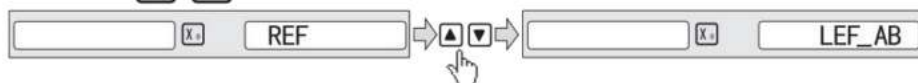

3、 Message window displays “LEF\_AB” , Press **ENT** until “ZERO\_AB” appears in message window.

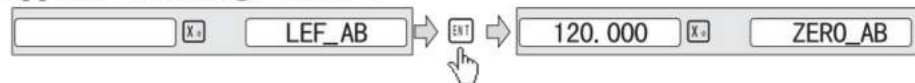

4、 Move the machine table to be set zero position piont. then press **X** , X axis will be zeroing . the current position for the absolute datum zero. the DRO returns normal display state.

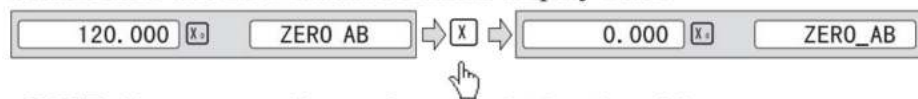

NOTE: Linear range without reference point location of the user

## General Operations

### 4.10 Non Linear Error Compensation

First compensation Type ( Linear or Non-Linear) in parameter setting must be set Non-Linear. Linear scale have a ref point location and find to the Absolute Reference Point will be enable.

Default Non-Linear compensation : 50.

#### Example for Y axis:

Step 1: Search the Absolute Reference Point of Scale;

Step 2: Press **[NP]** , then the message window display “COMP X” .



Step 3: Press **[▲]** **[▼]**, then the message window display “COMP Y”



Step 4: Press **[ENT]**, then the message window display “NUMBER” .

Then input the compensation parameter NUMBER.



Step 5: Press **[▲]** **[▼]**, then message window displays “Y-MSN-1” which indicates the step is to Non Linear Error Compensation.

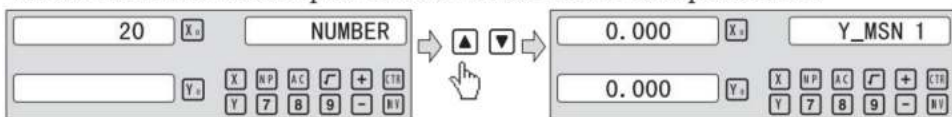

Step 6: Input compensation value .

X window display the value of the measurement value.

Y window display the value of the standard value.

Example for the first compensation point:

Measurement value :68.288mm. Standard value: 68.200mm



Step 7: After input all parameter, the DRO automatically exit.



2、 Set the point sdm1 as the datum of SDM 1. Move the machine worktable to  $x = 60.000$ ,  $y = 45.000$ . Then proess  $X_0$   $Y_0$ .

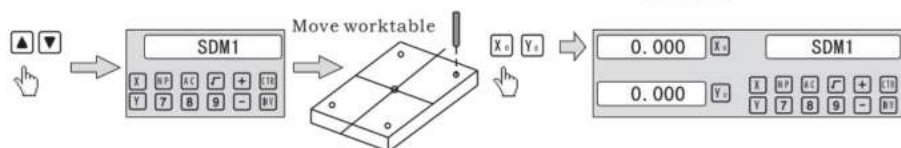

2、 Set the point sdm1 as the datum of SDM 2. Move the machine worktable to  $x = 60.000$ ,  $y = -45.000$ . Then proess  $X_0$   $Y_0$ .

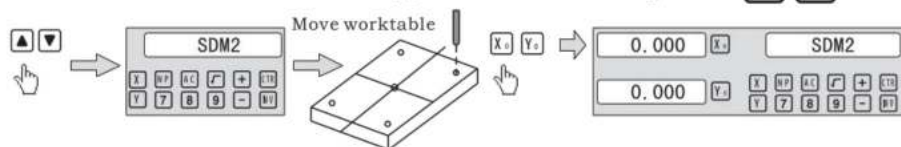

3、 Set the point sdm1 as the datum of SDM 3. Move the machine worktable to  $x = -60.000$ ,  $y = -45.000$ . Then proess  $X_0$   $Y_0$ .

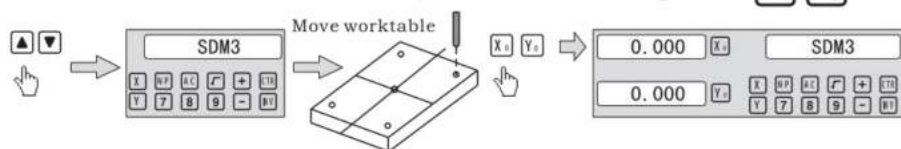

4、 Set the point sdm1 as the datum of SDM 4. Move the machine worktable to  $x = -60.000$ ,  $y = 45.000$ . Then proess  $X_0$   $Y_0$ .

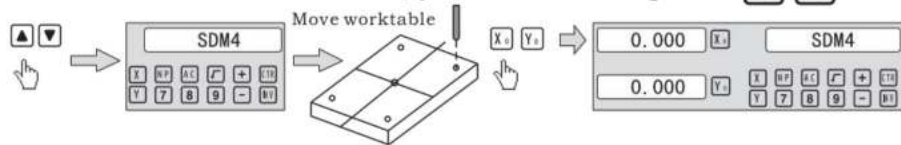

## 5.2 Preset datum of SDM coordinate

There are the same sample as Method 1. First Move the worktable to place the TOOL exactly at the origin of ABS, secondly Enter the ABS Mode as follow.

### Steps:

1、 Move worktable to place the TOOL at the center of the workpiece point O as the datum of ABS. Then zero X axis and Y axis in SDM 1 ; Zero X axis and Y axis in SDM 2 ; Zero X axis and Y axis in SDM 3 ; Zero X axis and Y axis in SDM 4.

## 200 Groups SDM coordinate

2、 Set point sdm1 as the datum of SDM 1. Press  $\blacktriangle$   $\blacktriangledown$ , then the message window display “SDM 1” . Input x = 60.000, y = 45.000.

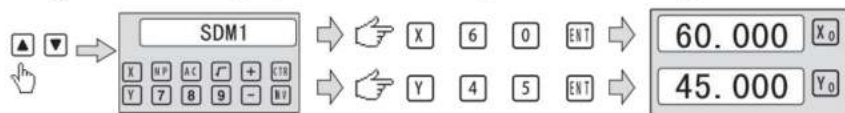

3、 Set point sdm1 as the datum of SDM 2. Press  $\blacktriangle$   $\blacktriangledown$ , then the message window display “SDM 2” . Input x = -60.000, y = 45.000.

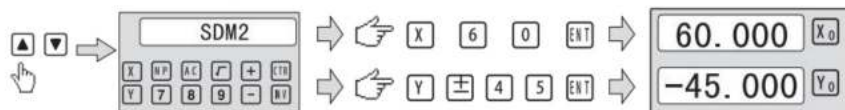

4、 Set point sdm1 as the datum of SDM 3. Press  $\blacktriangle$   $\blacktriangledown$ , then the message window display “SDM 3” . Input x = -60.000, y = -45.000.

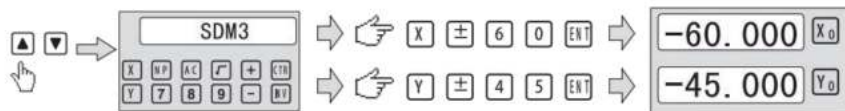

5、 Set point sdm1 as the datum of SDM 4. Press  $\blacktriangle$   $\blacktriangledown$ , then the message window display “SDM 4” . Input x = -60.000, y = 45.000.



## Funzione speciale

---

6. Funzione speciale

## Circumference Holes Processing

### 6.1 Circumference Holes Processing

The Function of PCD Hole positioning on Circumference is used to distribute arc equally, such as boring hole on flange. The right window will show the parameter to be defined when selecting PCD Function.

The Parameters to be defined are:

PCD_XY(XZ,YZ)	Select place
CENTER	Center position
DIA	Diameter of circle
NO_HOLE	Hole number
ST ANG	Starting angle
ED ANG	Ending angle

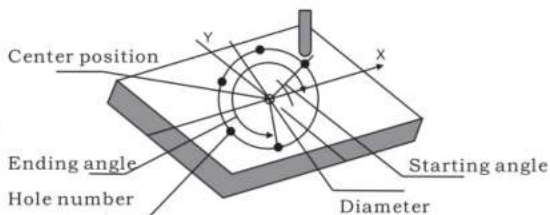

The position of the hole center are calculated automatically after input all parameters. Press or to choose the hole No. and move the machine table until the “0.000” appears in X window , Y window, Z window. It is the position to process a table.

Example for the XY place: Machine hole on circumference as the figure

PCD_XY(XZ,YZ)	XY
CENTER	X=0,000,Y=0.000
DIA	100,000
NO_HOLE	5
ST ANG	30,000
ED ANG	315,000

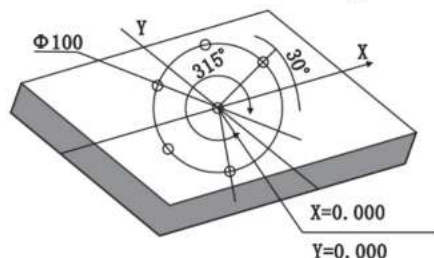

Steps:

1. Set display unit to metric in normal state; Move the machine table until the machine TOOL is aligned with the center of the circle , then zero X axis ,Y axis.

2. Select place.

Press , then the message window display “PCD\_XY” to the Circumference Holes Processing. Press or to select XY place.



## Circumference Holes Processing

## 2. Input center position.

Press **ENT** , then the message window display “CENTER” . X and Y window displays the formerly preset center position. Input X = 0, Y = 0 as follow.

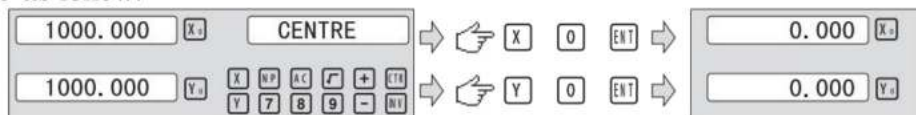

## 4. Input diameter.

Press **▼** until “DIA” appears in the message window. X window displays the formerly preset diameter. Then input the diameter is 100.000.

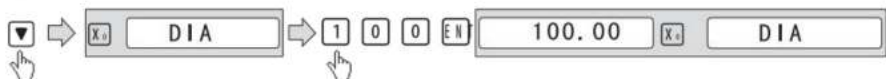

## 5. Input number.

Press **▼** until “NO\_HOLE” appears in the message window. X window displays the formerly preset number. Then press **5** in turn to input number.



## 6. Input starting angle.

Press **▼** until “ST ANG” appears in the message window. X window displays the formerly preset the starting angle. Then press **3** **0** in turn to input the starting angle.



## 7. Input ending angle.

Press **▼** until “ED ANG” appears in the message window. X window displays the formerly preset the ending angle.. Then press **3** **1** **5** in turn to input the ending angle.

## Circumference Holes Processing



8. Press  until “NO 1” appears in the message window.

It is the position of the first hole to punch where the “0.000” is displayed in X window and Y window by moving the machine table.

After finishing the first hole, press  or  to change holes number.

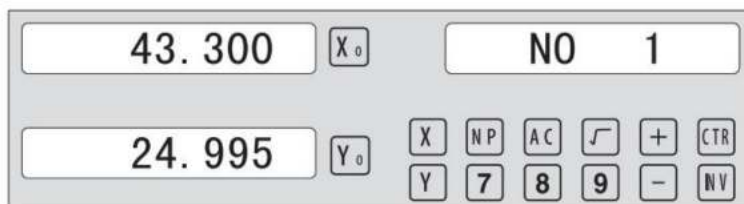

9. After processing all holes, press  to return normal display.

## Linear Holes Processing

### 6.2 Linear Holes Processing

There are two modes to carry out the linear drilling: Length mode and Step mode.

1.LINE S	Step mode
LINE L	Length mode
2.STEP	Step length
LENGTH	Line length
3. ANG	Angle
4. NO.HOLE	Hole number

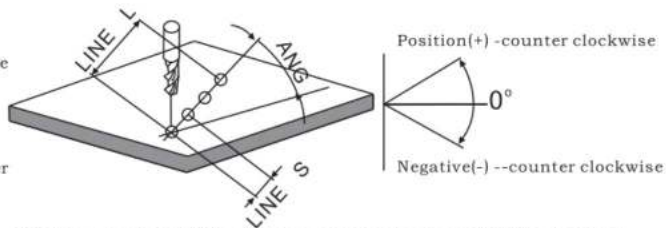

Linear Holes function can simplify the processing multiple holes whose centers are attributed equally on one line.

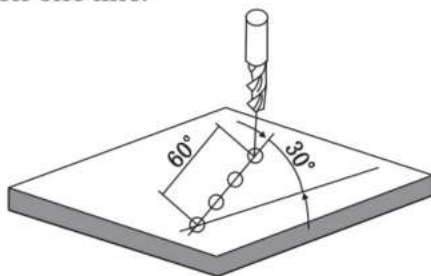

Example :

LINE_L	Length mode
LENGTH	60.000
ANG	30.000
NO.HOLE	4





Steps :

1. Select piece.

Press , then the message window display "LINE\_XY" to the Linear Holes Processing. Press  or  to select XY place.



2. Select Linear Holes mode.

Press , then the message window display "LINE\_S". Press  or  to select "LINE\_L".



3. Input linear length;

Press , then the message window display "LENGTH".

## Linear Holes Processing

X window displays the formerly preset the linear length. Press   in turn to input the linear length.



## 4. Input angle;

Message window displays “ANG” which indicates the step is to angle. X window displays the formerly preset the angle. Press   in turn to input the angle.



## 5. Input number;

Message window displays “ANG” which indicates the step is to angle. X window displays the formerly preset the number. Press  in turn to input the number.



6. Press  until “NO 1” appears in the message window.

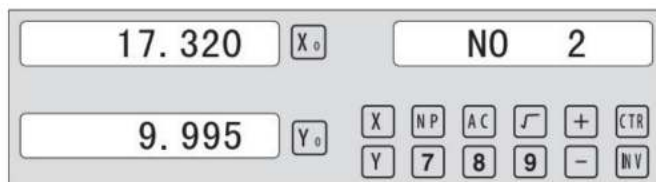

It is the position of the first hole to punch where the “0.000” is displayed in X window and Y window by moving the machine table. After finishing the first hole, press  or  to change holes number.



7. After processing all holes, press  to return normal display.

## 6.3 Elaborazione ARC

Per la funzione ARC sono disponibili DUE funzioni: la semplice ARC

Funzione e funzione R regolare · premere quindi pr css  per accedere alla funzione ARC,  o  per selezionare la funzione ARC regolare o semplice Funzione ARC.

Durante l'installazione, normalmente vengono prese in considerazione le coordinate della macchina e del direzione di X, Y , Z sono come segue. Il piano di lavoro è mostrato AS the figura giusta.

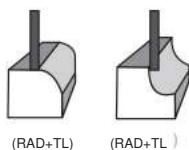

Z(+direzione positiva)

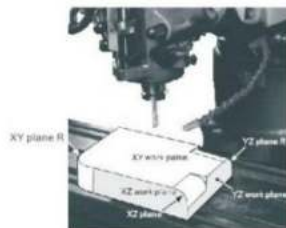
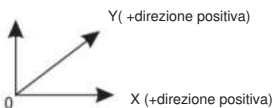

semplice funzione ARC:

quando la scorrevolezza non è molto richiesta, il SIMPLE ARC

la funzione è normalmente utilizzata per la lavorazione dell'arco. Nella funzione SIMPLE ci sono solo otto tipi di ARC utilizzati per la macchina. L'operatore deve solo selezionare il tipo di R e inserisci i parametri del raggio dell'arco

MAX CUT e Qrc esterno o arco interno. In generale, un arco può essere lavorati da una scanalatura piana T OOL Oppure arco TOOL, la differenza tra su piani di lavoro diversi come mostrato di seguito ·

- |     |                  |                       |
|-----|------------------|-----------------------|
| 1 , | SEMPLICE         | elaborazione semplice |
| 2 , | TIPO 1 - 8       | Modalità dell'ARC.    |
| 3,  | SEL_XY(XZ, YZ)   | selezione luogo       |
| 4 , | RAD              | Raggio dell'arco      |
| 5   | TL LUI           | Diametro utensile     |
| 6   | γ TAGLIO MASSIMO | Fase di alimentazione |
| 7   | γ RADTL _        | arco esterno e        |
|     |                  | arco interno          |
- (solo per posto xy)

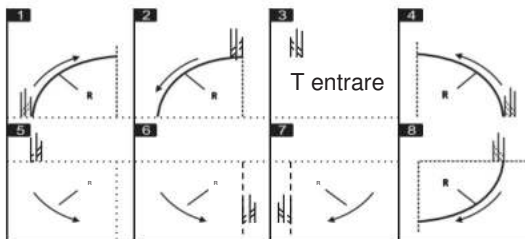

## ARC Processing

---

### Smooth ARC function :

Provides maximum flexibility in ARC machining, the ARC sector to be machined by the coordinates of ARC. Very flexible, ARC function can machine virtually all kinds of ARC, even the intersected ARC. Relatively a bit complicated to operate, operator need to calculate and enter the coordinates of ARC centre, start angle and end angle.

Basic parameter as follow:

1. SMOOTH	Mode of the Smooth ARC processing;
2. SEL_XY(YZ, XZ)	Select place;
3. CENTER	Refer to the position of an center.
4. RAD	Radius of the ARC
5. TL_DIA	Diameter of the TOOL
6. MAX_CUT	Feed step
7. ST_ANG	Starting angle
8. ED_ANG	Ending angle
9. RAD+TL	Outer arc.
RAD-TL	Inner arc.

### Example 1 for the Simple ARC Processing:

Parameters settings as follow:

SIMPLE	Simple mode
TYPE	3
SEL_XY	XY
RAD	80.000
TL_DIA	6.000
MAX_CUT	0.500
RAD+TL	1

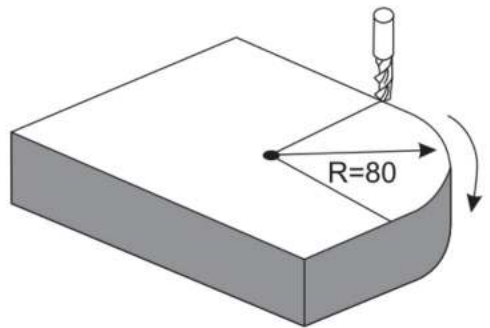

### Steps:

1. Select process mode

Press  , then the message window display “SIMPLE” to the ARC Processing. Press  or  to select mode of the simple, The message window display “SIMPLE”

## ARC Processing



2. Input the type:

Press **ENT** until “TYPE” appears in the message window. X-window displays the formerly preset type. Press **3** in turn



3. Select place

Press **ENT** until “SEL\_XY” appears in the message window.

Press **▲** or **▼** to select place to display “SEL\_XY”;



4. Input radius:

Press **ENT** until “RAD” appears in the message window. X-window displays the formerly preset radius of ARC. Press **80** in turn to input the radius.;



5. Input Diameter of the TOOL

Press **▲** or **▼** until “TL DIA” appears in the message window. X-window displays the formerly preset Diameter of the TOOL. Press **6** in turn to input the Diameter value;







6. Input Feed step (MAX\_CUT);



Press **▲** or **▼** until “MAX\_CUT” appears in the message window. X-window displays the formerly preset MAX\_CUT. Press **0.5** in turn to input the MAX\_CUT value;



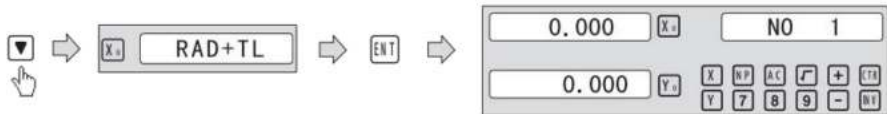

## ARC Processing

## 7. Select outer arc or inner arc

Press  or  until “RAD-TL” appears in the message window. Press  or  to select place to display “RAD+TL” ;

8. After inputting all parameters, press the key  for machining.

The DRO will display the position of the first point. Retract the axes until the displays read 0.000, Machine the Arc point by point in accordance with the display. After finishing the position of the first point, press  or  to change position point.

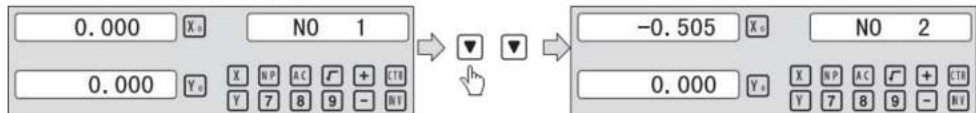

Press  to quit R function any time.

**Example 2 for the Simple ARC Processing:**

Parameters settings as follow:

SIMPLE	Simple mode
TYPE	3
SEL_XY	XZ
RAD	80.000
TL_DIA	6.000
MAX_CUT	0.500

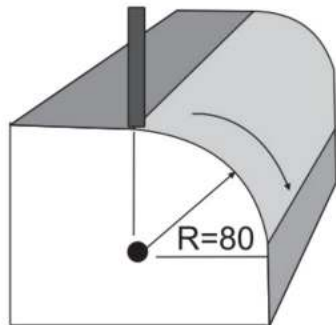

Steps:

1. Press , then the message window display “SIMPLE” to the ARC Processing. Press  or  to select mode of the simple, The message window display “SIMPLE”

## ARC Processing



2. Input the type:

Press **ENT** until “TYPE” appears in the message window. X-window displays the formerly preset type. Press **3** in turn



3. Select place

Press **ENT** until “SEL\_XZ” appears in the message window.

Press **▲** or **▼** to select place to display “SEL\_XZ” ;



4. Input radius:

Press **ENT** until “RAD” appears in the message window. X window displays the formerly preset the radius of ARC. Press **80** in turn to input the radius.;



5. Input Diameter of the TOOL

Press **▲** or **▼** until “TL DIA” appears in the message window. X window displays the formerly preset the Diameter of the TOOL. Press **6** in turn to input the Diameter value;



6. Input Feed step (MAX\_CUT);

Press **▲** or **▼** until “MAX\_CUT” appears in the message window. X window displays the formerly preset the MAX\_CUT. Press **0.5** in turn to input the MAX\_CUT value;



## ARC Processing

7. After inputting all parameters, press the key **ENT** for machining.

For 2-axis milling machine table, It is not installed with Z-axis, please press **▲** or **▼** to simulate position of Z-axis. Press **▲** simulate moving to the former process, and press **▼** simulate moving to the next process point.

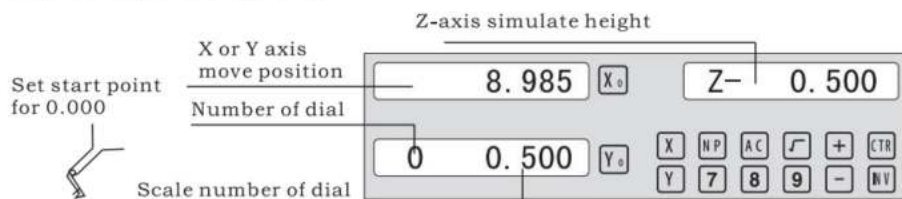

Z-axis simulate height = Number of dial x Z axis Dial + Scale number of dial

Press **▼** to quit R function any time.

### Example 3 for the Smooth ARC function:

Parameters settings as follow:

SMOOTH	Smooth mode
SEL_XY(YZ,XZ)	XY
CENTER	X=0,Y=0
RAD	80.000
TL_DIA	6.000
MAX_CUT	0.500
ST_ANG	0.000
ED_ANG	135.000
RAD+TL	1

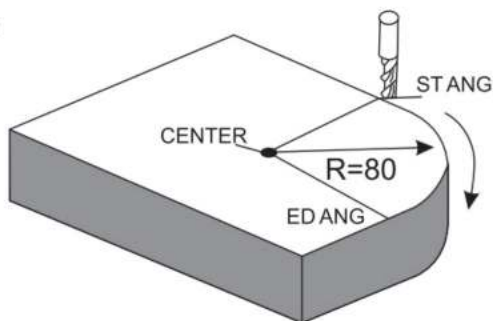

Steps:

1. Press **▼**, then the message window display "SIMPLE" to the ARC Processing. Press **▲** or **▼** to select mode of the simple, The

## ARC Processing

message window display “SMOOTH” ; For 3-axis milling machine table without this step. In second step. Then press **ENT** .



### 2. Select place

Message window display “SEL\_XY” which indicates the select is to place. Press **▲** or **▼** to select place to display “SEL\_XY” ;

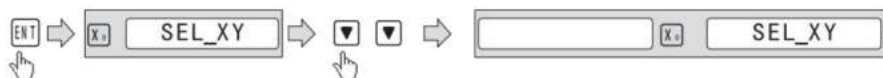

### 3. Input center position.

Press **ENT** , then the message window display “CENTER” . X and Y window displays the formerly preset center position. Input X = 0, Y = 0 as follow.

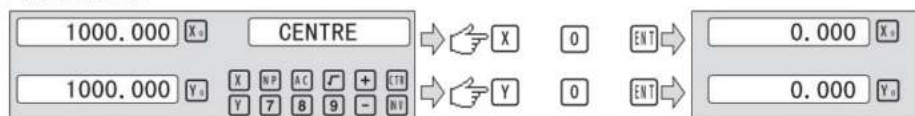

### 4. Input radius:

Press **ENT** until “RAD” appears in the message window. X window displays the formerly preset the radius of ARC. Press **8** **0** in turn to input the radius.;



### 5. Input Diameter of the TOOL



Press **▲** or **▼** until “TL DIA” appears in the message window. X window displays the formerly preset the Diameter of the TOOL. Press **6** in turn to input the Diameter value;



6. Passaggio di alimentazione in ingresso (MAX\_CUT);

premere  o  fino a quando l'app UM<sup>X</sup> CUT non compare nel messaggio

finestra. X Window de spa lys il preset precedente MAX\_CUT. premere

   a sua volta per immettere il valore MAX CUT;



7. Inserire l'angolo di partenza .

premere  finché non appare USTANG" nella finestra del messaggio.x

finestra de spa lys l'angolo di partenza precedentemente preimpostato . Quindi premere

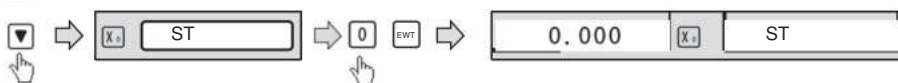

 a sua volta per immettere l'angolo di partenza-



8 . Angolo finale di input .



premere  finché nella finestra del messaggio non appare "UED ANG". X

finestra ispa lys il precedentemente preimpostato l'angolo finale. Quindi premere

  a sua volta per immettere l'angolo endin8-



9 . seleziona arco esterno o arco interno

premere  o  finché non compare "RAD-TL" nel messaggio

finestra.premere  o  per selezionare il luogo in cui visualizzare "RAD+TL";

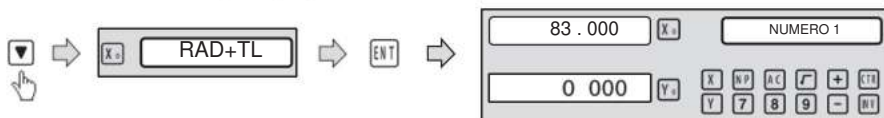

10. Dopo aver inserito tutti i parametri,

**machining.**

Il DRO visualizzerà la posizione del primo punto. Ritirare il

assi finché i display non leggono 0. 000, lavora l'arco punto per punto in  
in accordo con il display. Dopo aver terminato la posizione del primo

punto, premere  o  per cambiare punto di posizione.

## ARC Processing

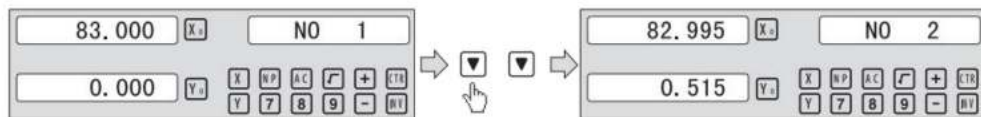

Press  to quit ARC function any time.

## 6.4 elaborazione obliqua

Ci sono 2 modi disponibili per lavorare in posizione obliqua:

A). sul posto. b). sul posto yz, o Xz;

è necessario immettere solo i seguenti parametri:

INCLUSO	Xy(xz,yz)	imposta la posizione della macchina xy,yz,0rxz ·
IL		L'angolo di inclinazione dell'obliquo·
LÀ		Diametro dell'UTENSILE ·
ST POT		Posizione di partenza;
ED PUÒ		Fine della pubblicazione;

## Esempio 1 per il posto xy obliquo:

quando il piano di lavorazione è sul piano xy come la parte mostrata in Figura, l'angolo di obliquità del pezzo in lavorazione deve essere calibrato prima che il piano obliquo venga lavorato. Pertanto , a questo punto il la lavorazione del piano obliquo svolge il ruolo di calibrare l'obliquità ·

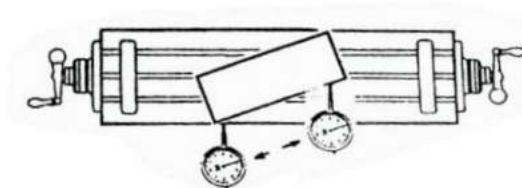

procedura per la calibrazione dell'obliquità

Per prima cosa posizionare il pezzo da lavorare sul tavolo da lavoro secondo l'angolazione richiesta di obliquità ·

1) Inserire la funzione del piano obliquo. 2)

Selezionare la funzione del piano XY.

3) Inserire l'angolo di obliquità

4) Spostare il tavolo di lavoro fino a quando lo strumento di misura (ad esempio un comparatore a quadrante) installato sulla fresatrice tocca il piano di calibrazione dell'obliquità, lo regola a zero e sposta il tavolo di lavoro per qualsiasi distanza nella direzione dell'asse  $x_z$ .

5) Spostare il tavolo di lavoro nella distanza dell'asse y fino a quando il display diventa zero.



## Oblique Processing

---

6) Change the angle of the work piece to make the workpiece touch the measuring tool and adjust it to zero.

STEPS:



1. Select place

Press , then the message window display "INCL\_XY" to the Oblique Processing. Press  or  to select place to display "SEL\_XY";

Then press  to in next step;



2. Input the angle of obliquity

The message window display "ANG" , X window displays the formerly preset the angle of obliquity. Press   in turn to input the angle of obliquity .



3. Move the workpiece along the X-Axis until the measuring tool touches the workpiece adjust it to zero, and move the worktable for any distance along the X-Axis.



4. Press , display the value of Y-Axis. Move the workpiece along the Y-Axis, change the angle of workpiece to make the obliquity-calibrating plane touch the measuring tool until it turns to zero. Move the worktable until Y-Axis is displayed as zero.

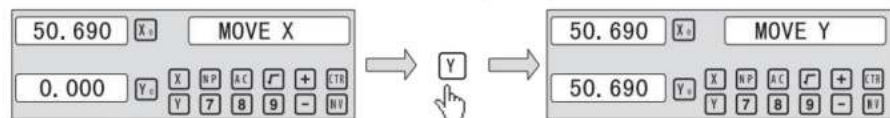

5. Press  to quit oblique function any time.

## Oblique Processing

### Example 2 for the oblique XZ or YZ place:

When the machining plane is on plane XZ or YZ, the function of TOOL inclination can instruct the operator to machine the oblique plane step by step.



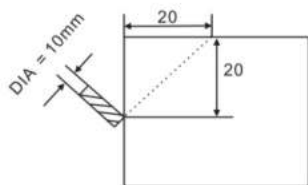
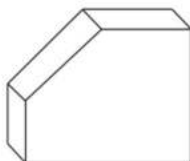

Procedures for using the function of cutter inclination:

When the machining plane is on plane XZ or YZ, first please calibrate the obliquity of the primary spindle nose and set the TOOL:

INCL_XY(XZ,YZ)	INCL_XZ
DIA	10.000
ST_POT	20.000
ED_POT	20.000





#### STEPS:

1. Press , then the message window display “INCL\_XY” to the oblique Processing. Press  or  to select place to display “SEL\_XZ; Then press  to in next step;



2. Input The TOOL Diameter

The message window display “DIA” , X window displays the formerly preset the angle of obliquity. Press   in turn to input the TOOL Diameter of obliquity . OK, then press  to in next step;



3. Input ST\_POT;

The message window display “ST\_POT” , X and Y window displays the formerly preset the stating position of obliquity. Input X= 0, Y = -20.000. OK, then press  to in next step;

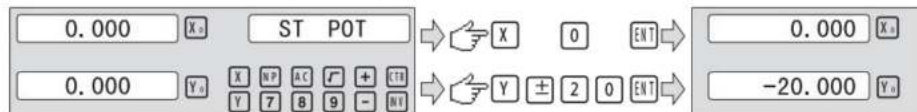

## Oblique Processing



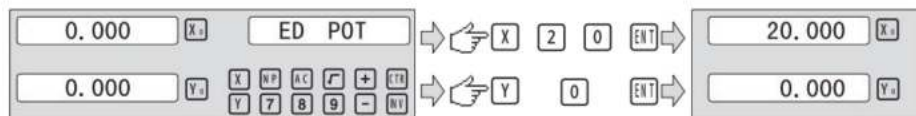

---

### 4. Input ED\_POT;

The message window display “ED\_POT” , X and Y window displays the formerly preset the starting position of obliquity. Input X= 20.000, Y = 0.000 .



### 5. After input all parameter, press the key for machining.

For 2-axis milling machine table , It is not installed with Z-axis, please press  or  to simulate position of Z-axis. Press  simulate moving to the former process, and press  simulate moving to the next process point.

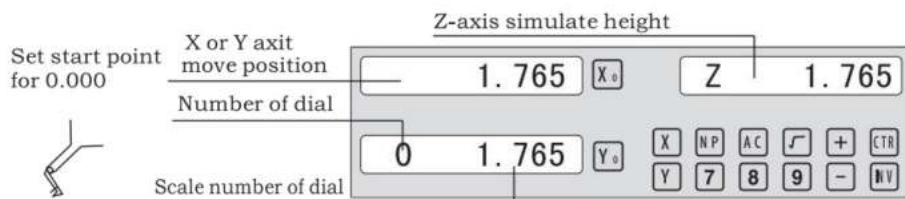

Z-axis simulate height = Number of dial x Z axis Dial + Scale number of dial

Press  to quit **oblique** function any time.

## Slope Processing



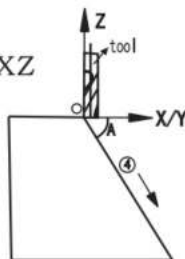

## 6.5 Slope Processing

This function can calculate the position of every processing point automatically in processing slope. Only the following parameters need to be inputted:

XZ, YZ	Set machine place YZ, or XZ
ANG	The inclination angle
Z_STEP	The slope length each time processing



**Example 1 for the Slope XZ place;**

Step 1. Select place

Press , then the message window display “XZ” to the slope Processing. Press  or  to select place to display “SEL\_XY; Then press  to in next step;





Step 2. Input the angle of slope

The message window display “ANG”, X window displays the formerly preset the angle of slope. Press   in turn.



Step 3. Input Z\_step;

The message window display “Z STEP”, X window displays the formerly preset the stating position of slope. Input    in turn.



Step 4:Finishing the ALL processing . Press  to quit slope function any time.

## Chambering Processing

### 6.6 Chambering Processing

1, FLAT\_XY: machine place; 2, DIA:diameter of TOOL; 3, CENTER: center of the chambering ; 4, SIZE: size of the chambering ;

Figure as follow:

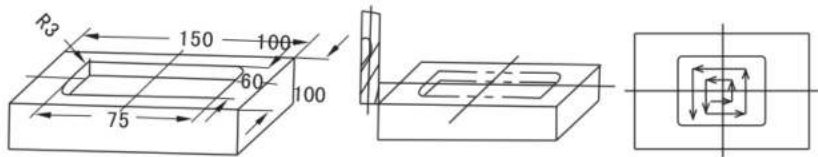

STEPS:

1. Press , then the message window display “FLAT\_XY” to the Chambering Processing.



2. Input DIA of the TOOL;





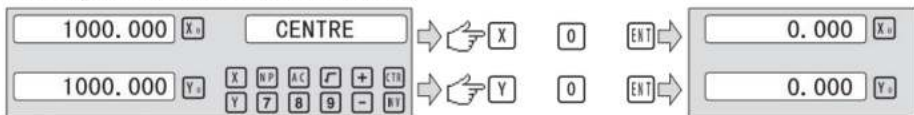

3. Input the center coordinate;

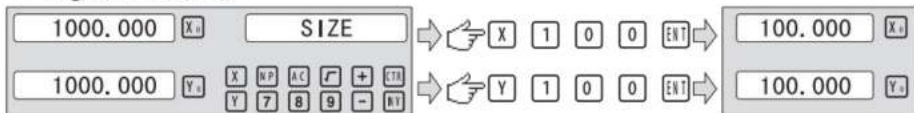

4. Input the size;



5. process Chambering;

Move the machine until the display of the axis is zero, ie, the position of the first point. Machine the first point . Display the next machining point by pressing  or  .On the completion of machining, the right window shows OVER. Press  or  , the system will goto the first position for the next workpiece. Press  to quit the Chambering Function.

## The Tool Diameter Compensation Function

### 6.7 The Tool Diameter Compensation Function

Without TOOL compensation, the operator has to move the TOOL for an additional distance of the diameter of the TOOL along each side when machining the four 150 and 100 sides of a workpiece to finish machining the whole brim. The digital readouts shall automatically compensate when the TOOL compensation function is enable.

Note: the TOOL compensation is made in the direction of X and Yaxis.

Procedures:

- 1). Enter the function of compensating the diameter of the TOOL.
- 2). Select one of the (four) preset machining modes.
- 3). Input the diameter of the TOOL.
- 4). Enter machining.

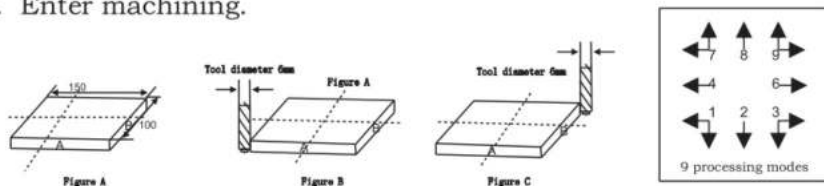

Step1: press  $\frac{D}{1}$  to enter the TOOL compensation Function. then the message window display “TYPE” .Press **9** .



Step 2: input the diameter of the TOOL; Press **1** **0** in turn..



Step 3: Press  $\nabla$  to the machining Mode.

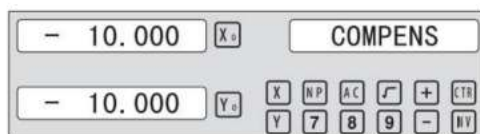

Machining of 2 side planes can be done by moving the TOOL until X-Axis is 150.000 and Y-Axis is 100.000.Press the Key  $\frac{D}{3}$  to quit the Function.

## The Tool Diameter Compensation Function

---

### 6.8 Digital Filter of the Grinding Machine

When machine a work-piece by grinder, the display values quickly due to the vibration of grinder. User can not see display value clearly. Grinder DRO provides display value filter function to disable the quake change of display value.

STEPS:

1. Enter display value filter function.

In normal display state, press **SFT** to simultaneously, enter display value filter function.

2. Exit display value filter function;

Press **SFT** , exit display value filter function;

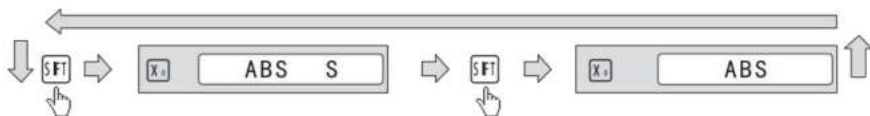

## 6.9 La funzione

## 6.9.1 200 set di librerie TOOL

Per elaborare parti diverse è sempre necessario uno STRUMENTO diverso. Per funzionamento conveniente, la La le letture digitali hanno la funzione di 200 set di librerie TOOL.

Nota: solo quando il la è dotato del blocco di impostazione degli utensili è possibile utilizzare le 200 librerie TOOL.

1. impostare un dato TOOL. Dopo l'impostazione dell'utensile, azzerare l'asse x e l'asse Z, il imposta lo zero della coordinata assoluta.

2. In base alla dimensione di TOOL I e datumTOOL, determinare il posizione di TOOL relativa allo zero della coordinata assoluta e dello strumento di riferimento. AS

Figura 6-1. La dimensione relativa di TOOL 2 è AS segue l'asse x 25-30=

, Asse Z 20-10=10.

3. Salvare il numero dello STRUMENTO e la dimensione nel display digitale.

4. Il numero di TOOL può essere inserito in modo casuale, le letture digitali visualizzerà la posizione dell'utensile rispetto alla coordinata assoluta zero. Sposta la finché sia l'asse X che l'asse Z non visualizzano zero.

Le librerie TOOL possono salvare 200 set di dati degli utensili.

6. Le librerie TOOL devono essere utilizzate nello stato di apertura. I 200 set rooi Libs può essere aperto premendo continuamente  dieci volte finché la finestra di destra lampeggia TL - OPEN e viene visualizzato un segno "21" la finestra informativa a sinistra della destra. Il Mark indica il

l'operatore può configurare o rivedere i 200 set di librerie TOOL in modo continuo

premendo il tasto  dieci volte causerà la cancellazione delle 200 librerie TOOL da chiuso e il finestrino destro lampeggia TL - CLOSE e il Mark

scompaiono. quando il segno "21" scompare, le librerie TOOL set 200 possono non essere rivisto

Le operazioni per i dati TOOL e la chiamata a TOOL sono illustrate di seguito. passaggio 1: nello stato ABS, immettere i dati dei 200 set di librerie TOOL.

apertura dei 200 set TOOL Libs premendo continuamente il tasto

 dieci volte A. Il segno "" apparirà nella finestra di sinistra della finestra di destra finestra informativa.

## Lathe Function

passo 2: premere **TOOL** per ACCEDERE allo stato di immissione. Inserisci i dati rooi 1:

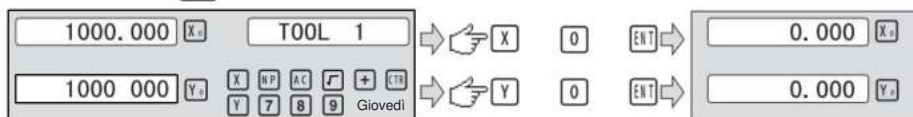

passaggio 3: immissione dati TOOL 2:

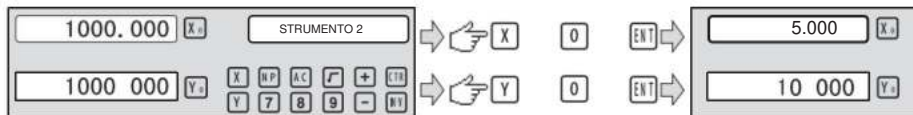

passo 4: premere per continuare a immettere i dati dello strumento successivo. Premendo

numero e il tasto **Y** l'operatore può immettere direttamente lo speciale datistrumentali. stampa **TOOL** tocca

Dopo aver configurato le librerie TOOL, utilizzare le librerie TOOL in base a operazioni successive montare prima il secondo utensile .

passaggio 5: Per accedere allo stato di utilizzo tramite pr css **CALL** . Quindi pr css **2** **ENT** **T** .



passo G: premere **▲** o **▼** . seleziona il rotolo base. Quindi premi **1** **ENT** .



passo 7: premere **CALL** per uscire dalla funzione;

Nota:

quando viene utilizzato lo strumento base , l'asse non può essere azzerato nello stato ABS .  
quando gli altri vengono utilizzati , l'asse può essere azzerato solo nello stato INC .

### 6 . 9 . 2 Funzione di riduzione

Per la tornitura del pezzo con conicità, la conicità del pezzo può essere misurato in fase di elaborazione;

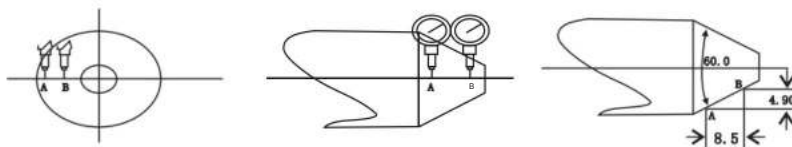

## Lathe Function

### Operations :

Figura AS, superficie di contatto A del pezzo in lavorazione con letture a leva e ripristina il punto di lettura della leva a zero .

passaggio 1: premere  quindi la finestra del messaggio visualizza "UMEASU" per elaborazione della carta . Spostare la lettura della leva sulla superficie B finché il le letture della leva indicano come segue;



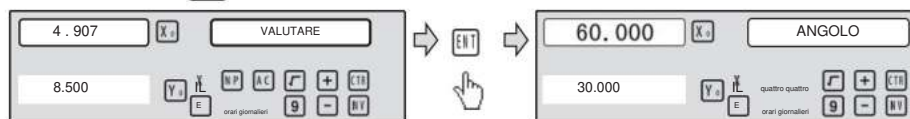

passaggio 2: premere  T per calcolare.



passaggio 3: premere  per uscire dalla funzione;

### 6 . 9 . 3 Funzione R/D

Per tornio a 2 assi e tornio a 3 assi, premere  , La modalità di visualizzazione l'asse ofx viene commutato tra Raggio e Diametro. quando l'asse x per visualizzazione del diametro, un segno u finestra  " apparirà a sinistra della destra informativa, ma quando l'asse X per la visualizzazione di un metro  , il segno " " scompare . solo l'asse x ha la funzione di diametro/raggio transformation.

### 6 . 9 . 4 Funzione Y + Z (applicabile solo a: 3 assi La the)

Per 3 assi La, il contatore dell'asse y e il contatore dell'asse z

Può essere aggiunto alla visualizzazione sull'asse Z premendo il tasto  ,

quindi premere il tasto CAn per annullare la funzione y + Z .

6.10 EDM (funzione di personalizzazione speciale, se è necessario acquistarla, si prega di contattare il rivenditore per la personalizzazione)

<sup>1</sup> Descrizione: Questa funzione viene utilizzata per la lavorazione speciale di Elettroerosione (EDM). quando il valore target impostato per l'EDM L'asse Z è uguale al valore attuale, il display digitale emetterà il valore segnale di commutazione per controllare l'EDM per interrompere la lavorazione in profondità.

L'impostazione della direzione dell'asse Z del display digitale è mostrata come nella figura 1 , cioè Più profonda è la profondità, maggiore è il valore delle coordinate dell'asse Z visualizza · dall'inizio della lavorazione, la profondità aumenterà gradualmente e asse Z.

In base alla direzione dell'asse Z impostata, la direzione di lavorazione è divisa in lavorazione positiva e negativa · quando l'elettrodo scende e la lavorazione viene eseguita dall'alto verso il basso, il digitale il valore di lettura aumenterà, e ciò viene definito lavorazione positiva (positiva). L'impostazione di questa direzione è l'impostazione normale-

quando l'elettrodo ASCENDS e la lavorazione viene eseguita dal basso verso l'alto, il valore della lettura digitale diminuirà · Il la direzione di lavorazione è la direzione negativa (negativa), che è anche chiamata lavorazione negativa (mostrata come Fig. 1)

Il Digital Readout presenta anche altre funzioni , come ad esempio negativo altezza ignifuga. La funzione altezza ignifuga negativa è un tipo di posizione intelligente segui controllo dispositivo di protezione di sicurezza. Nel processo della lavorazione, la superficie dell'elettrodo genererà il carbonio fenomeno di accumulo. A causa del lungo tempo o della lavorazione diurna senza tendere, quando si genera l'accumulo di carbonio e nessuno fa la pulizia, l'elettrodo aumenterà lentamente lungo la direzione negativa · una volta che l'elettrodo supera il livello del liquido, spesso prendono fuoco e causano perdite. Questa funzione è impostata solo per mirare a questo problema. quando si imposta un'altezza ignifuga negativa, e il l'altezza aumentata dell'elettrodo supera l'altezza tra esso e l' profondità della superficie lavorata (cioè altezza ignifuga negativa), il digitale il display di lettura lampeggerà per WQring; allo stesso tempo, l'uscita il segnale disattiverà automaticamente l'EDM per eliminare il rischio di incendio ·



Figura 1



Figura 2

## 2. procedura:

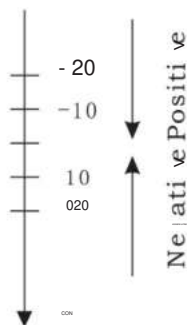
vedere l'esempio seguente per la lavorazione dettagliata

1) Prima della lavorazione, impostare innanzitutto ogni parametro di PROFONDITÀ (profondità di lavorazione); ERRHIGH (altezza ignifuga negativa), lavorazione direzione (POSITIVO / NEGATIVO); modalità di uscita (AUTO/STOP) e Modalità di uscita del relè EDM .

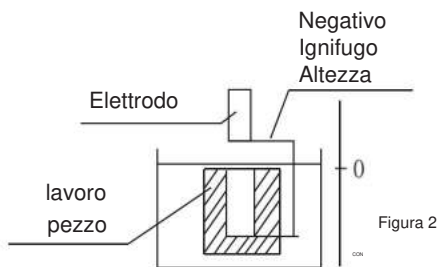
2) Spostare l'elettrodo dell'asse principale dell'asse Z per farlo entrare in contatto con riferimento del pezzo · azzerare l'asse A o impostare il valore ·

3) Entrare nella lavorazione EDM premendo il tasto  ·

4) L'asse X visualizzerà il valore target della profondità di lavorazione · L'asse Y visualizzerà il valore visualizzato è stato la profondità. (Il valore sull'asse Y è il valore che il pezzo è stato lavorato in profondità) L'asse Z sarà visualizza il valore in tempo reale della posizione di sé. (Il valore sull'asse Z è il valore di posizione dell'elettrodo dell'asse principale dell'asse z.)

5) avviare la lavorazione, il valore visualizzato sull'asse Z si avvicina gradualmente al valore target, e il valore visualizzato sull'asse y è anche gradualmente vicino al valore target. Se in questo momento l'elettrodo viene ripetutamente Su e Giù, il valore visualizzato sull'asse Z cambierà successivamente, ma il valore visualizzato sull'asse Y il valore non cambierà, e verrà sempre visualizzata la profondità lavorata **value**.

6) quando il valore visualizzato sull'asse Z è uguale al valore target impostato, il l'interruttore di posizione raggiunto verrà spento, l'EDM interromperà la lavorazione, In base alle impostazioni dell'operatore, sono disponibili due tipi di modalità di uscita:

## a) Automatic Mode:

it will automatically exit from EDM machining status and recover to the original state before machining;

## b) Stop Mode:

It will always stay at the machining interface after finishing machining, and you should press **EDM** to exit and back to the original state.

**Operation steps:**

**The DEPTH (machining Depth), ERRHIGH (Negative fireproof height), exit Mode, EDM Relay Output Mode and machining direction should be set.**

**STEPS:**

1. Press **EDM** to enter the EDM Function. Press **▲** to input parameters; Press **▼** to enter EDM machining state.

2. Input DEPTH ( machining depth). Press the key **▲** to set the next parameter.



3. input ERRHIGH ( Negative Fireproof Height ) (undefine) .Press the key **▲** to set the next parameter.



4. Set machining direction(Positive or Negative). Press **1** to select Positive direction. Press **0** to select Negative direction. Press the key **▲** to set the next parameter.



## EDM

5. Set exit Mode (AUTO Mode or STOP Mode) Press **0** to select AUTO Mode; Press **1** to select STOP Mode ; Press the key **▲** to set the next parameter.

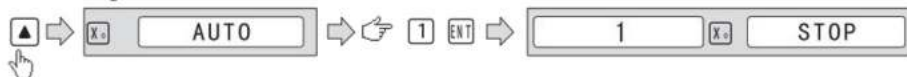

6. Set the Output Mode (Mode 0 or Mode 1); ( undefine ). Press **0** to select Mode 0; Press **1** to select Mode 1.

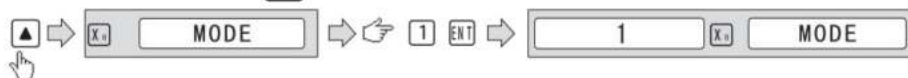

7. Continuously press **▼** to return EDM for machining. press **EDM** to quit the function;

### Example 1: positive direction machining ;

Machining is shown as the model chamber as follows

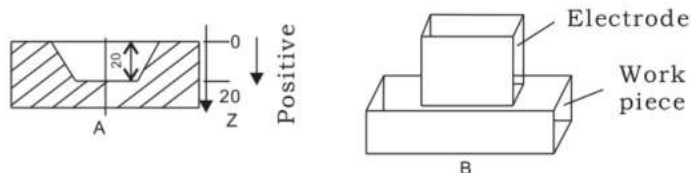

#### STEPS:

1、Touch one side of the workpiece with the TOOL, then press **Z0** , zero the Z axis.



2、 Press **EDM** , Setting DEPTH for 20.000; press **▼** to EDM for machining;



3、 Starting machining.

## EDM

Machining depth target value	<input type="text" value="20.000"/>	<input type="button" value="X0"/>	<input type="button" value="EDM RUN"/>
Value has been to be depth	<input type="text" value="0.000"/>	<input type="button" value="Y0"/>	
Self-position real time value	<input type="text" value="0.000"/>	<input type="button" value="Z0"/>	

**Example 2: Negative direction machining**

Machining is shown as the model chamber as follows

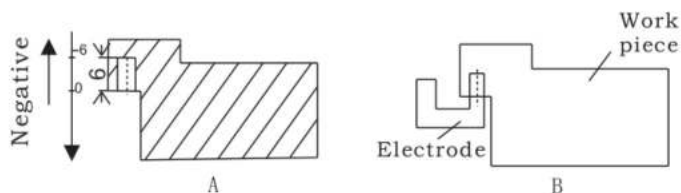

- 1、Touch one side of the workpiece with the TOOL, then press  , zero the Z axis.

<input type="text" value="1000.000"/>	<input type="button" value="Z0"/>	<input type="button" value="↔"/>	<input type="button" value="Z0"/>	<input type="button" value="↔"/>	<input type="text" value="0.000"/>	<input type="button" value="Z0"/>
---------------------------------------	-----------------------------------	----------------------------------	-----------------------------------	----------------------------------	------------------------------------	-----------------------------------

- 2、Press  , Setting DEPTH for -20.000; press  to EDM for machining;

<input type="button" value="EDM"/>	<input type="button" value="→"/>	<input type="button" value="X0"/>	<input type="text" value="DEPTH"/>	<input type="button" value="↔"/>	<input type="button" value="±"/>	<input type="text" value="20"/>	<input type="button" value="ENT"/>	<input type="text" value="-20.000"/>	<input type="button" value="X0"/>	<input type="text" value="DEPTH"/>
------------------------------------	----------------------------------	-----------------------------------	------------------------------------	----------------------------------	----------------------------------	---------------------------------	------------------------------------	--------------------------------------	-----------------------------------	------------------------------------

- 3、Starting machining.

Machining depth target value	<input type="text" value="20.000"/>	<input type="button" value="X0"/>	<input type="button" value="EDM RUN"/>
Value has been to be depth	<input type="text" value="0.000"/>	<input type="button" value="Y0"/>	
Self-position real time value	<input type="text" value="0.000"/>	<input type="button" value="Z0"/>	

**Example 3: PCD Function for EDM**

PCD Function can access the EDM Function . The operator enters PCD Function to input parameters for PCD and enter PCD machining state. At every position for machining, press the key  to access the EDM Function .



quando si accede alla funzione EDM, l'operatore può immettere i parametri per EDM .

La procedura operativa è la seguente:

1) impostare i parametri PCD (l'impostazione è la stessa dell'impostazione comune del PCD)

Dopo aver inserito tutti i parametri ed essere entrati nello stato di lavorazione PCD . Il verrà visualizzata la posizione del primo foro.

2) premere  per immettere il parametro della funzione EDM (il metodo di impostazione è lo stesso dell'impostazione comune del parametro EDM); dopo aver inserito tutti i

parametri, premere continuamente quando la  per entrare nello stato di lavorazione EDM. lavoro è terminata, premere Invio Stato di  per uscire dalla funzione EDM e lavoro PCD .

3) Nello stato di lavorazione PCD, premere  per la posizione della buca successiva, OVE la macchina al valore di visualizzazione 0 , quindi pr css  per accedere

Funzione EDM di nuovo . 4)

Ripetere i passaggi 2 e 3 per i seguenti punti di lavorazione.

## Calculator

### 7 calcolatrice

La calcolatrice non fornisce solo normali calcoli matematici come +, - ,  $\times$  , /, fornisce anche calcoli trigonometrici come AS

PECCATO , Arco SIN , COS , Arco COS , ABBRONZATO , Arco TAN SQRT ecc.

Le operazioni sono le stesse delle calcolatrici commerciali, facili da usare.

#### Funzione di entrata e uscita dalla calcolatrice

in stato di visualizzazione normale: premere R per accedere alla funzione calcolatrice.

nello stato di visualizzazione della calcolatrice: premere R per uscire dalla funzione calcolatrice.

Trasferimento dei risultati della calcolatrice per zx selezionato.

Dopo aver completato il calcolo, se la calcolatrice visualizza la modalità impostata per modalità 1 , l'utente può:

premere  $X_0$  per trasferire il risultato calcolato sull'asse tox; quindi l'asse x la finestra visualizzerà questo valore;

premere  $Y_0$  per trasferire il risultato calcolato sull'asse del giocattolo; quindi la finestra visualizzerà questo valore;

premere  $Z_0$  per trasferire il risultato calcolato sull'asse z; quindi z la finestra visualizzerà questo valore;

#### Trasferimento del valore corrente di Displayvalueinwindow alla calcolatrice.

se la calcolatrice visualizza la modalità impostata per la modalità 1 , l'utente può:

premere  $X$  per trasferire il valore visualizzato nella finestra x alla calcolatrice;

premere  $Y$  per trasferire il valore visualizzato nella finestra Y per calcolare r;

premere  $Z$  per trasferire il valore visualizzato nella finestra z alla calcolatrice;

## Appendix

## 8 Appendix

## 1. Troubleshooting:

The following are the preliminary solvents for troubleshooting.

If there is still trouble, Please contact out company or agents for help.

Troubles	Possible reasons	Solvents
No display	<ol style="list-style-type: none"> <li>1. Power isn't connected</li> <li>2. Power switch is off.</li> <li>3. The range of power voltage is not right.</li> <li>4. The inner power of Linear Scale is short.</li> </ol>	<ol style="list-style-type: none"> <li>1. Check power wire and connect the power</li> <li>2. Turn on the power switch.</li> <li>3. The range of voltage is in 80--260V</li> <li>4. Unplug the connector of linear scale</li> </ol>
One axis is not counting	<ol style="list-style-type: none"> <li>1. Replace the linear scale of the other axis.</li> <li>2. DRO is in special function</li> </ol>	<ol style="list-style-type: none"> <li>1. If count is normal, the linear scale has trouble; If abnormal, the DRO readouts has trouble.</li> <li>2. Quit the special function.</li> </ol>
Linear scale is not counting	<ol style="list-style-type: none"> <li>1. Reading head is bad for using range exceeds.</li> <li>2. Aluminum chips is in reading head of linear scale.</li> <li>3. The span between the reading head and metal part of linear scale is large.</li> <li>4. The metal parts of linear scale is damage.</li> </ol>	<ol style="list-style-type: none"> <li>1. Repair the linear scale</li> <li>2. Repair the linear scale</li> <li>3. Repair the linear scale</li> <li>4. Repair the linear scale</li> </ol>
Counting is error	<ol style="list-style-type: none"> <li>1. Shell is poor grounding.</li> <li>2. Low precision of machine.</li> <li>3. Speed of machine is too rapid.</li> <li>4. Precision of linear scale is low.</li> <li>5. The resolution of DRO readouts and the linear scale is not match.</li> <li>6. The unit (mm/inch) is not match.</li> <li>7. Setting the linear compensating is not arrest.</li> <li>8. Reading head of the linear scale is damaged.</li> </ol>	<ol style="list-style-type: none"> <li>1. Shell is good grounding.</li> <li>2. Repair the machine.</li> <li>3. Reduce the speed of machine.</li> <li>4. Mount the linear scale again.</li> <li>5. Set the resolution of the DRO again.</li> <li>6. Cover the unit of display mm/inch.</li> <li>7. Reset the linear compensation.</li> <li>8. Repair the linear scale.</li> </ol>
The counting of the linear scale is not accurate	<ol style="list-style-type: none"> <li>1. The mounting of linear scale does not demand the requirement, and the prcision is not adequate.</li> <li>2. The screw is loosen.</li> <li>3. Precision of machine is low.</li> <li>4. The resolution of digital readouts and the linear scale is not match.</li> </ol>	<ol style="list-style-type: none"> <li>1. Mount the linear scale again and level it.</li> <li>2. Lock all fixing screws.</li> <li>3. Repair the machine.</li> <li>4. Reset the resolution of digital readouts.</li> </ol>
Sometimes the linear scale is not counting	<ol style="list-style-type: none"> <li>1. The small car and steel ball is separated.</li> <li>2. The glass of reading head is wearied.</li> <li>3. The glass of reading head of the linear scale has dirt.</li> <li>4. The elasticity of the steel wire is not adequate.</li> </ol>	<ol style="list-style-type: none"> <li>1. Repair the linear scale.</li> <li>2. Repair the linear scale.</li> <li>3. Repair the linear scale.</li> <li>4. Repair the linear scale.</li> </ol>

## Appendix

### 2. Specifications of Digital Readout.

- 1) Supply Voltage range: AC 85 V ~ 230 V; 50 ~ 60 Hz
- 2) Power consumption: 15VA
- 3) Operating temperature: 0°C-- 50°C
- 4) Storage temperature: - 30°C-- 70°C
- 5) Relative humidity: < 90 % ( 25 )
- 6) Max Coordinate number: 3
- 7) Readout allowable input signal: TTL square wave
- 8) Allowable input signal frequency: < 5 M Hz
- 9) Max resolution of digital display length: 0.01 um
- 10) Max resolution of digital display angle: 0.0001 / PULSE

### 3. Instructions

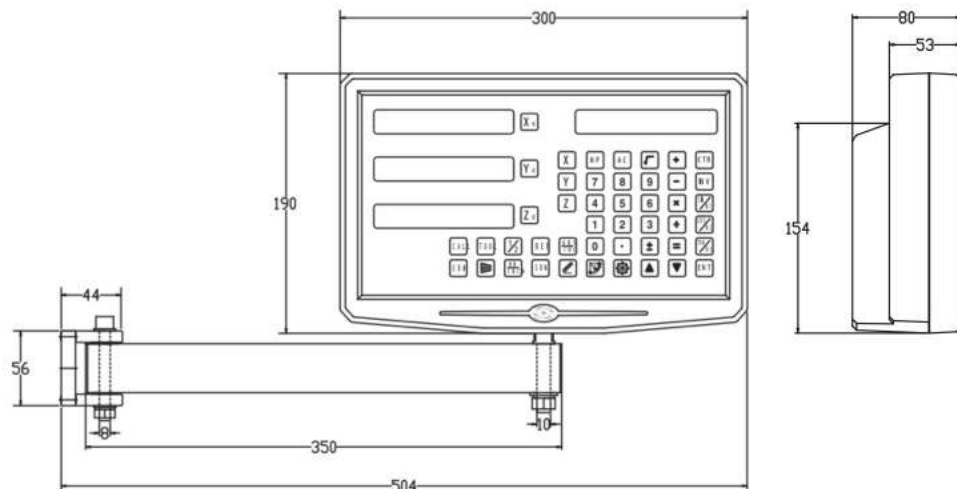

## 4. Examples of character output at the data interface

## 1、 X,Y,Z Axis

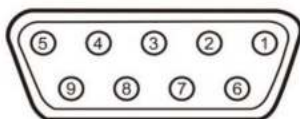

Pin	TTL (Standard)
1	
2	OV
3	
4	
5	
6	A+
7	5V
8	B+
9	R+

Pin	TTL (Standard)
1	5V
2	OV
3	A+
4	B+
5	R+
6	
7	
8	
9	

For your convenience,  
If you buy a digital readout,

The wiring definition of your linear scale must be the same as the 2 definitions in the above diagram to be universal!

## Installation Instructions

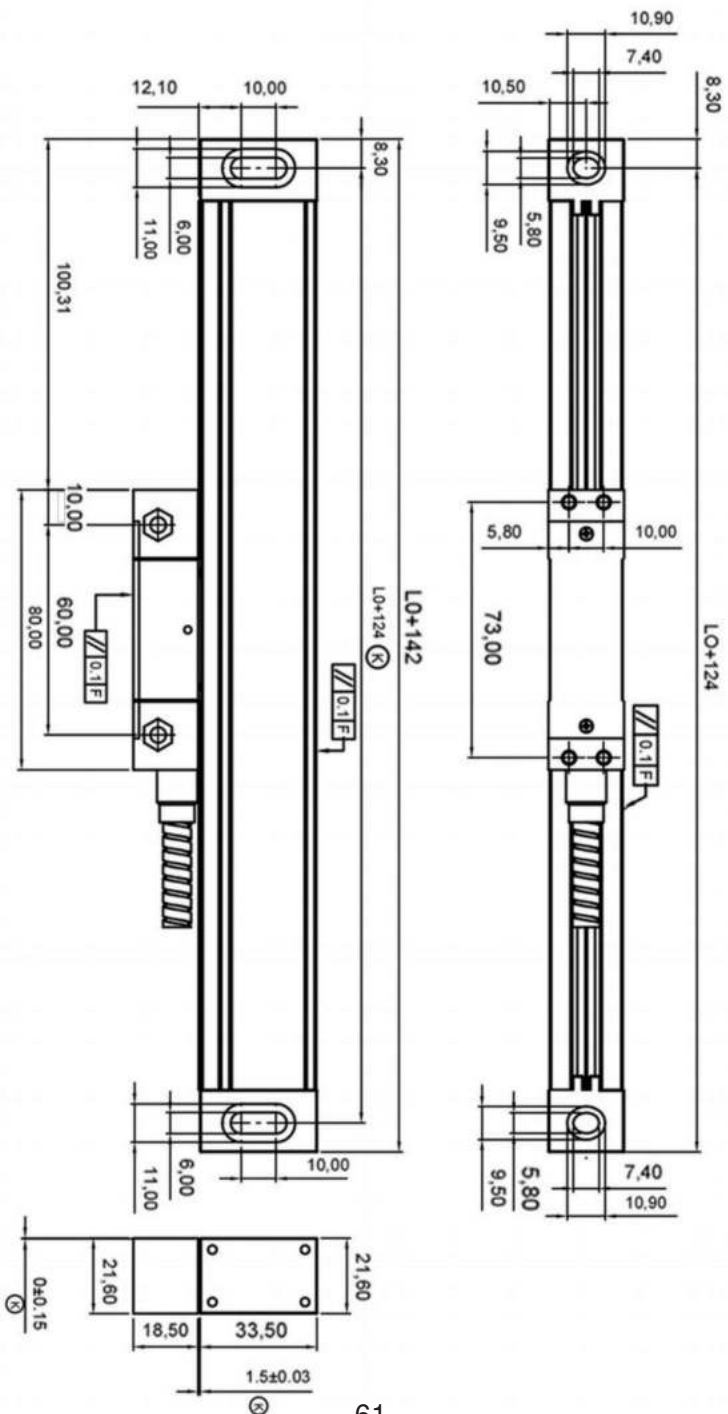

## TTL signal Output:

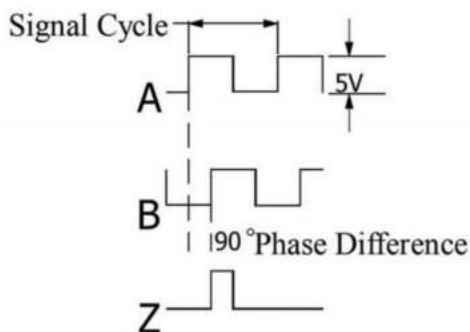

## EIA-422-A signal Output:

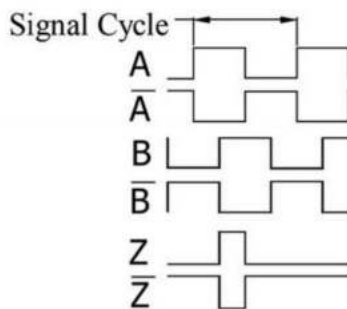

## 1. TECHNICAL PARAMETER

1.1 SCALING DISTANCE: 0.02 MM (50LINES /MM)

1.2 RESOLUTION: 5 $\mu$ M、1 $\mu$ M、0.5 $\mu$ M1.3 PRECISION:  $\pm 3\mu$ M、 $\pm 5\mu$ M、 $\pm 15\mu$ M/M (20 $\pm$ 0.1°C)

1.4 MEASURING RANGE: 30~3000MM

1.5 MOVING SPEED: HIGH-SPEED ENCODER 120 M/MIN (TO BE CUSTOMIZED)

ORDINARY ENCODER 60M/MIN

1.6 POWER SUPPLY: +5V $\pm$ 5%、80MA

1.7 CABLE LENGTH: STANDARD 3M (SPECIAL LENGTH AVAILABLE ACCORDING TO THE USER'S NEEDS)☑

1.8 WORKING TEMPERATURE: 0~45°C

1.9 PIN DESCRIPTION:

1) APPLICABLE TO: 9 PIN SOCKET EIA-422-A SIGNAL OUTPUT.

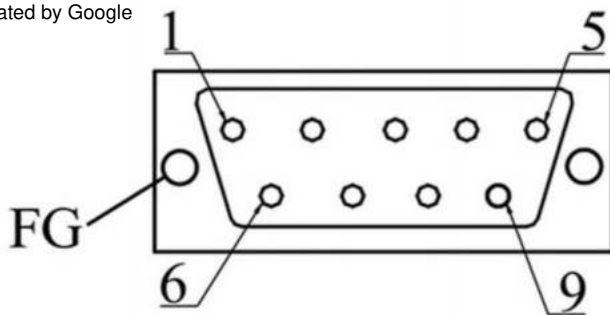

1) Applicable to: 9 pin socket EIA-422-A signal Output.

Pin Position	1	2	3	4	5	6	7	8	9
Signal	$\bar{A}$	$OV$	$\bar{B}$	Empty	$\bar{Z}$	$A$	+5V	$B$	$Z$
Color	Green Black	Black	Orange black	FG	White black	Green	Red	White	Orange

FG: Shield connected to metal casing.

1) Applicable to: 9 pin socket TTL signal Output.

Pin Position	1	2	3	4	5	6	7	8	9
Signal		$OV$		Empty		$A$	+5V	$B$	$Z$
Color		Black		FG		Green	Red	Orange	White

FG: Shield connected to metal casing.

# **Scala lineare**

## **Disegni di installazione**

## Metodo di installazione:

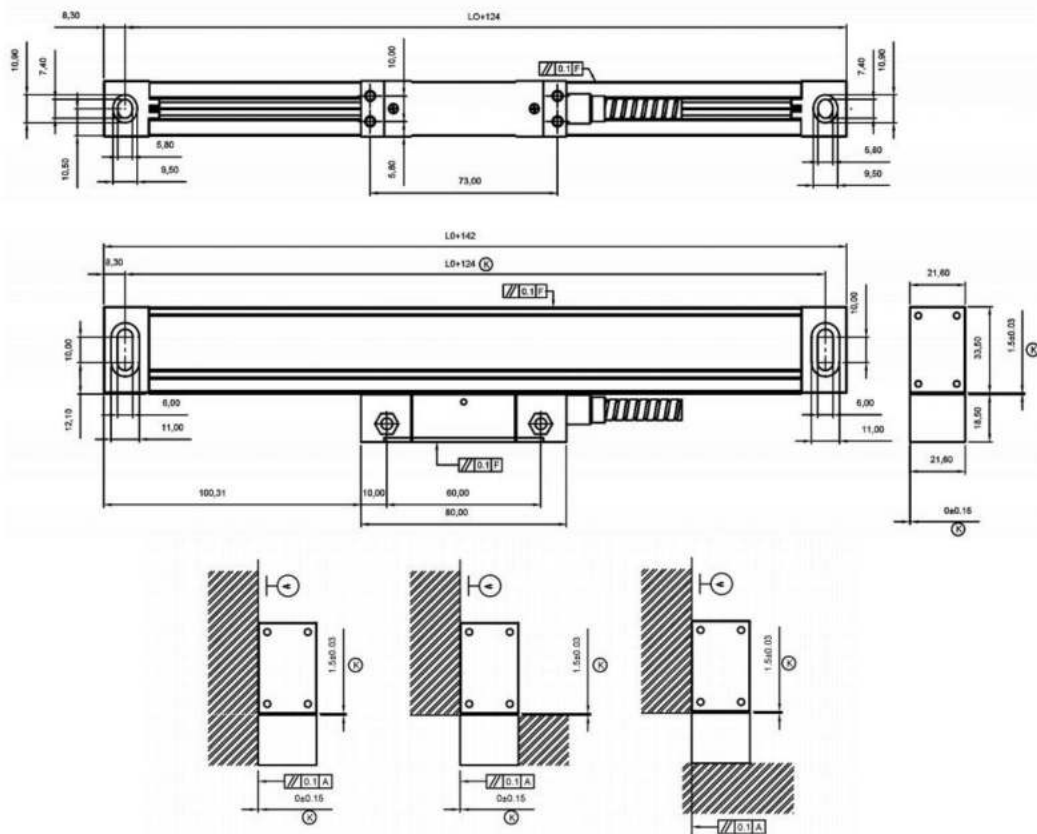

Misura standard: (Unità:mm)

Modello	ESSO	L1	L2	Modello	L0	L1	L2
YE-50	50	174	190	YE-550 550		674	690
YE-100	100	224	240	YE-600	600	724	740
YE-150	150	274	290	Modello YE-650 650	650	774	790
Anno-200 200		324	340	YE-700 700		824	840
YE-250 250		374	390	YE-750	750	874	890
YE-300 300		424	440	YE-800	800	924	940
YE-350 350		474	490	YE-850 850		974	990
YE-400 400		524	540	YE-900	900	1024	1040
YE-450 450		574	590	YE-950 950		1074	1090
YE-500 500		624	640	YE-1000 1000		1124	1140

L0: Lunghezza di misura effettiva dell'encoder lineare; L1: Lunghezza dell'encoder lineare fuori di montaggio; L2: lunghezza complessiva dell'encoder lineare

## Manutenzione:

1. La corsa effettiva dell'encoder lineare deve essere più lunga del massimo corsa della macchina utensile. Se la lunghezza non è sufficiente, sostituire l'encoder lineare con una corsa maggiore o aggiungere un blocco di fine corsa sulle macchine. La posizione finale della testina di lettura dall'estremità del corpo dell'encoder lineare non deve essere inferiore a 10 mm di spazio (vedere il diagramma seguente).

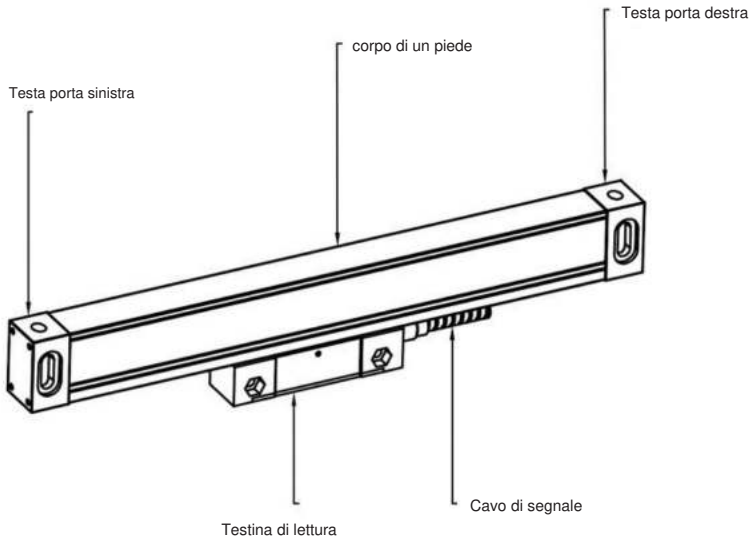

2. Per qualsiasi superficie non lavorata, è necessario posizionare un distanziale sul retro dell'encoder lineare oppure utilizzare un distanziale di installazione realizzato dall'utente per garantire la stabilità e l'affidabilità della connessione tra il righello a reticolo e la superficie di montaggio.
3. Quando si utilizza un comparatore a quadrante o uno strumento simile per calibrare il parallelismo dell'encoder lineare, l'angolo della testa laterale deve essere compreso tra  $\pm 30$  gradi e più piccolo è l'angolo, meglio è.

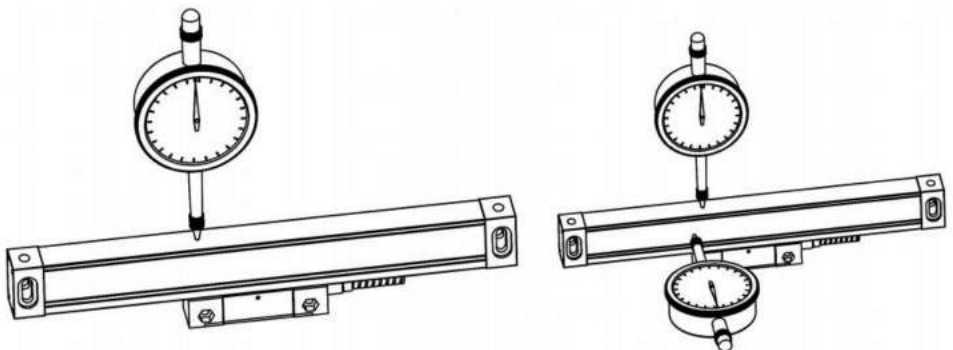

4. La posizione di installazione dell'encoder lineare deve evitare l'impatto diretto del ferro limatura, olio, acqua e polvere (come mostrato nella figura sottostante). La lunghezza di installazione della piastra L dovrebbe essere il più corta possibile in base alle circostanze possibili, e bisogna tenere conto della situazione di forza della superficie di montaggio.

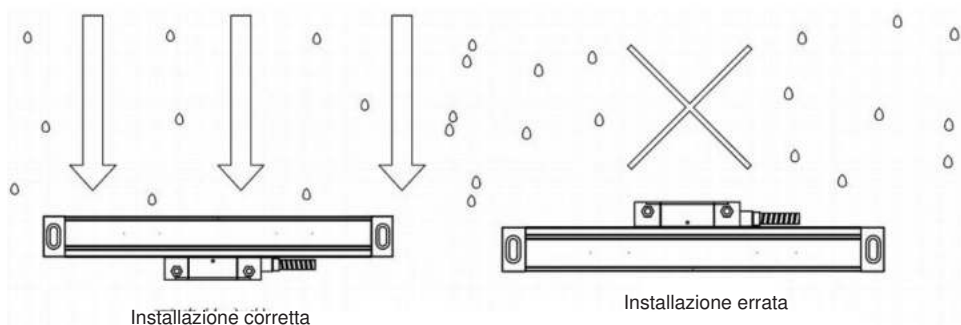

5. Deve esserci uno spazio di 0,5 mm o più tra la copertura antipolvere e il righello corpo ed evitare il contatto tra il coperchio antipolvere e il corpo del righello quando muovendo la testina di lettura (come sotto).
6. Profondità della filettatura della vite di installazione, deve avere almeno 6 denti di profondità di bloccaggio; forzare la parte più grande, come il supporto della piastra fissa del ripiano del misuratore del display digitale, deve avere 8 denti di profondità di bloccaggio; serie YE di scala, la profondità della filettatura deve essere uguale alla profondità di bloccaggio. Come il supporto del ripiano del misuratore del display digitale fisso piastra, deve avere una profondità di bloccaggio superiore a 8 denti; scala serie YE con viti M4 superficie di montaggio installata maschiatura dopo sbavatura superficiale, verniciatura, rimozione delle macchie. (La figura seguente)

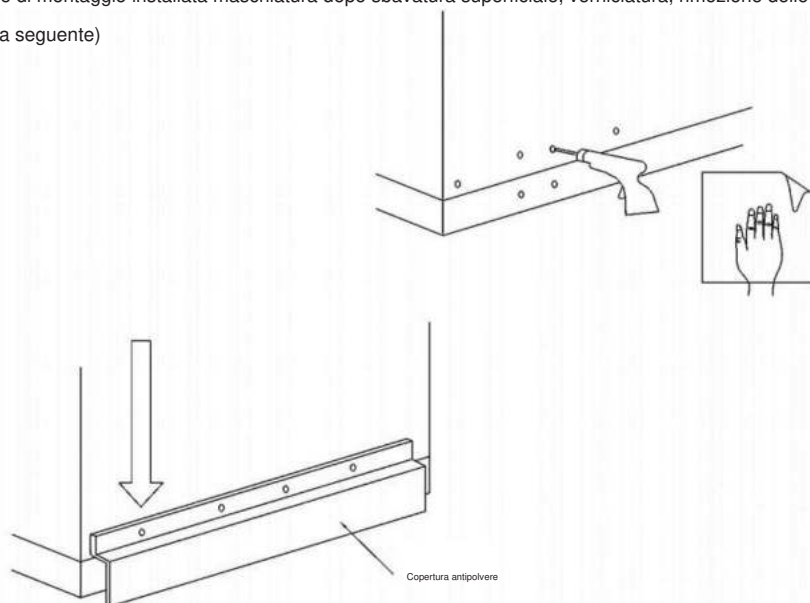

7. Il fissaggio della linea di segnale deve tenere conto di tutte le distanze di movimento rilevanti.

La posizione di fissaggio deve essere posizionata il più possibile al centro della corsa e la linea del segnale in eccesso viene fissata con una fascetta.

8. La regolazione del livello di altezza della scala deve essere la lunghezza del centro della scala per prendere i due lati del punto di simmetria. Regolare il punto di riferimento, qualsiasi scala indipendentemente dalla direzione del livello scolastico o dalla direzione dell'altezza, l'intervallo di regolazione: per il corpo della scala, alla testa dal corpo della scala a una distanza non superiore a 20 mm da ciascuna estremità prevarrà. Per la testina di lettura, tra le due superfici di riferimento quadrilatero (la figura seguente)

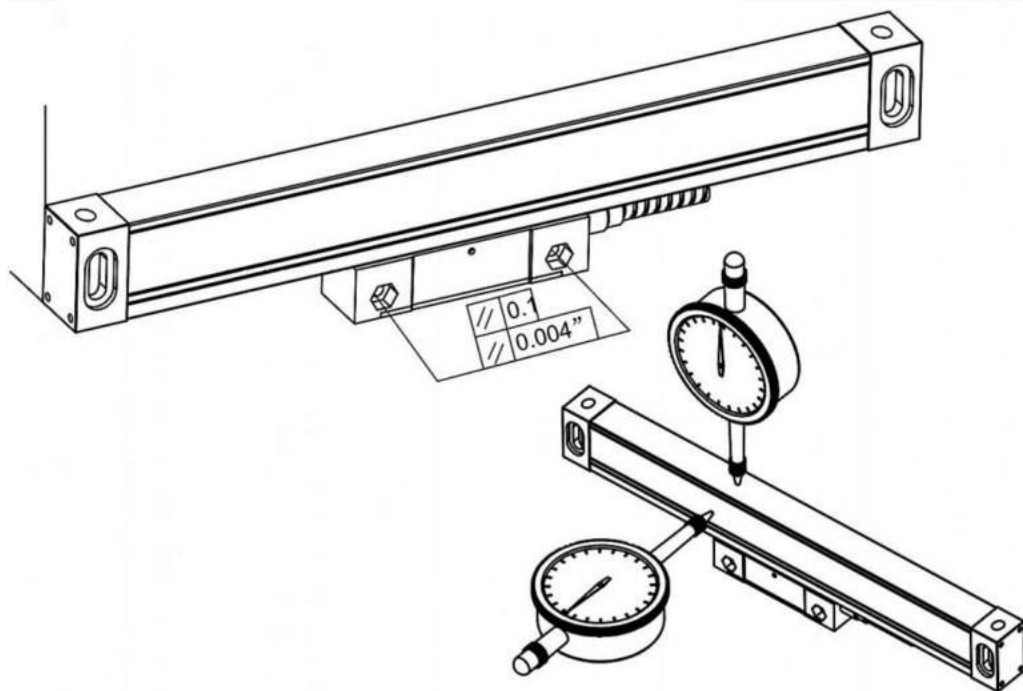

9. Il raggio di curvatura della linea del segnale della scala è maggiore di 60 mm.

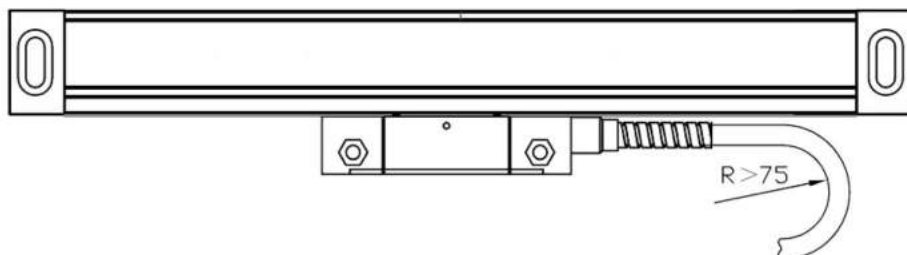

## 10. Standard di installazione della scala

(1) Standard di superficie di base dell'installazione (Figura 4.8abc tre metodi di installazione)

1. La superficie di installazione del corpo del righello è parallela alla superficie di installazione della testina di lettura e il parallelismo tra le superfici di installazione è  $<0,1$  mm
2. La superficie di installazione del corpo del righello è perpendicolare all'installazione superficie della testina di lettura e la perpendicolarità tra le superfici di installazione è  $<0,1$  mm

2) Standard di installazione del corpo del righello (Figura 4.9, Figura 4.10)

1. Direzione dell'altezza rispetto al parallelismo della guida della macchina  $<0,1$  mm, massimo non superiore a  $0,15$  mm In termini di punto di simmetria, più piccolo è, meglio è.

3) Standard di installazione della testina di lettura

1. Dopo l'installazione, la distanza tra la testina di lettura e la direzione dell'altezza del corpo del righello è di  $0,8$  mm- $1,6$  mm, quindi estrarre il blocco del pad (Figura 4.11)

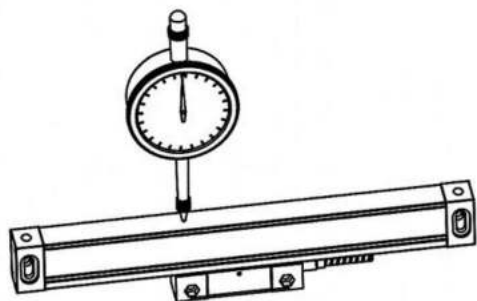

4.9

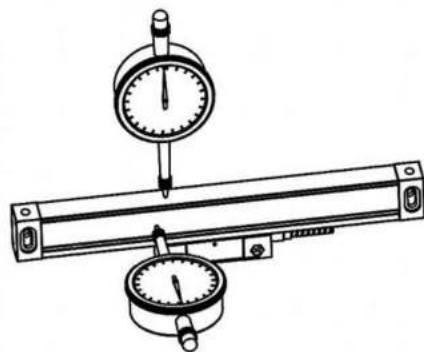

4.10

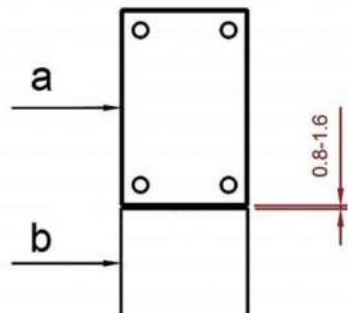

2. Testina di lettura lato A e corpo del righello lato B.  
Disallineamento in direzione orizzontale.  
 $0,25 \pm 0,15$  mm

3. Parallelismo della testina di lettura rispetto a  
macchina utensile  $<0,10$  mm, il massimo non può  
superare  $0,30$  mm

**Parametro:**

<b>Modelle</b>	SNS-3V-YE102024	SNS-3V-YE161838
<b>Rated voltage:</b>	AC85-230V 50Hz/60Hz	
<b>Resolution</b>	5 $\mu$ m	
<b>Number of axes</b>	3	
<b>Range</b>	10 inches 20 inches 24 inches	16 inches 18 inches 38 inches

**Accessori standard:**

<b>Accessories for digital display meters:</b>	<b>Accessories for grating ruler:</b>
<ol style="list-style-type: none"> <li>1. Support rod * 1</li> <li>2. Knife holder plate * 1</li> <li>3. Transparent watch case * 1</li> <li>4. Power cord * 1</li> <li>5. Watch holder * 1</li> <li>6. Butterfly piece * 2</li> <li>7. M8 * 70 screw * 1</li> <li>8. M10 * 55 screw * 1</li> <li>9. Nut M10 * 1</li> <li>10. Nut M8 * 1</li> <li>11. Nut M5 * 1</li> <li>12. Internal hexagonal screw M5 * 20 * 2</li> <li>13. Internal hexagonal screw M5 * 25 * 1</li> <li>14. M4 * hex socket screw * 4</li> <li>15. M5 * 10 machine meter screws * 2</li> <li>16. Washer <math>\phi</math> 10 * 1</li> <li>17. Washer <math>\phi</math> 8 * 1</li> <li>18. Washer <math>\phi</math> 5 * 1</li> <li>19. Rubber washer 20 * 10 * 1 * 1</li> <li>20. Rubber washer 20 * 10 * 0.5 * 1</li> <li>21. Spring washer <math>\phi</math> 10 * 1</li> <li>22. Spring washer <math>\phi</math> 8 * 1</li> <li>23. Spring washer <math>\phi</math> 5 * 1</li> </ol>	<ol style="list-style-type: none"> <li>1. Ruler cover * 3</li> <li>2. L mounting plate * 4</li> <li>3. Plug * 6</li> <li>4. Screw pack * 3 bags</li> </ol> <p>Each bag contains:</p> <p>Internal hexagonal screw M4 * 30 * 4;  Internal hexagonal screw M4 * 12 * 2;  Internal hexagonal screw M4 * 8 * 4;  U-shaped gasket T=0.2mm * 2;  Washer <math>\phi</math> 6 * 2;  Washer <math>\phi</math> 5 * 2;  Washer <math>\phi</math> 4 * 6;  Line card * 2</p>

Questo dispositivo è conforme alla Parte 15 delle Norme FCC. Il funzionamento è soggetto alle due condizioni seguenti: (1) Questo dispositivo non può causare interferenze dannose e (2) Questo dispositivo deve accettare qualsiasi interferenza ricevuta, comprese le interferenze che possono causare un funzionamento indesiderato.

**Produttore:** Shanghaimuxinmuyeyouxiangongsi

**Indirizzo:** Shuangchenglu 803nong11hao1602A-1609shi, baoshanqu, shanghai 200000 CN.

**Importato in AUS:** SIHAO PTY LTD, 1 ROKEVA STREETEASTWOOD NSW 2122 Australia

**Importato negli USA:** Sanven Technology Ltd., Suite 250, 9166 Anaheim Place, Rancho Cucamonga, CA 91730

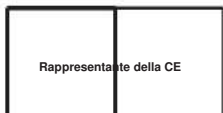

E-CrossStu GmbH

Mainzer Landstr.69, 60329 Francoforte sul Meno.



CONSULENZA YH LIMITATA.

C/O YH Consulting Limited Ufficio 147, Centurion House, Viale Europa, 101, 00186 Roma, Italia

**VEVOR**®  
TOUGH TOOLS, HALF PRICE

Supporto tecnico e certificato di garanzia elettronica

[www.vevor.com/support](http://www.vevor.com/support)

# VEVOR<sup>®</sup>

## TOUGH TOOLS, HALF PRICE

Soporte técnico y certificado de garantía electrónica

[www.vevor.com/support](http://www.vevor.com/support)

### MANUAL DEL USUARIO DE LA PANTALLA DRO

MODELO: SNS-3V-YE102024 ES NS-3V-YE161838

Seguimos comprometidos a brindarle herramientas a precios competitivos.

"salvar la mitad", "Mitad de precio" o cualquier otra expresión similar utilizada por nosotros sólo representa una estimación de los ahorros que podría obtener al comprar ciertas herramientas con nosotros en comparación con las principales marcas y no necesariamente significa cubrir todas las categorías de herramientas que ofrecemos.

Se le recuerda que debe verificar cuidadosamente cuando realice un pedido con nosotros si está

En realidad, ahorrando la mitad en comparación con las principales marcas líderes.

**VEVOR**<sup>®</sup>  
TOUGH TOOLS, HALF PRICE

PANTALLA DRO

MODELO: SNS-3V-YE102024 SNS-3V-YE161838



¿NECESITA AYUDA? ¡CONTÁCTENOS!

¿Tiene preguntas sobre el producto? ¿Necesita asistencia técnica? No dude en ponerse en contacto con nosotros.  
Contáctenos:

Soporte técnico y certificado de garantía electrónica  
[www.vevor.com/support](http://www.vevor.com/support)

Estas son las instrucciones originales, lea todas las instrucciones del manual.

Antes de utilizar el producto, lea atentamente el manual de usuario. VEVOR se reserva una interpretación clara de este manual. La apariencia del producto estará sujeta a las producto que recibió. Por favor, perdónenos por no informarle nuevamente si hay actualizaciones de tecnología o software en nuestro producto.

Estimados usuarios:

Gracias por adquirir lectores digitales de la serie multifunción.

Los lectores digitales se utilizan en una amplia variedad de aplicaciones. Estas incluyen: máquinas herramientas, en ejes de avance, equipos de medición e inspección, electroerosión y estaciones de aparatos divisores, herramientas de ajuste, medición para control de producción. Para cumplir con los requisitos de estos

Aplicaciones: Se pueden conectar muchos codificadores a las lecturas digitales.

Lea atentamente todas las instrucciones del manual antes de usarlo y

Sígalas estrictamente. Conserve el manual para futuras consultas.

Atención de seguridad:



Para evitar descargas eléctricas o incendios, humedad o rociado directo

Se debe evitar el uso de líquido refrigerante. En caso de humo o de que se produzcan

Si siente olor en la lectura digital, desconecte el cable de alimentación.

inmediatamente, de lo contrario, podría producirse un incendio o una descarga eléctrica.

En tal caso, no intente repararlo, comuníquese con la empresa o

**distributors.**



El lector digital es un dispositivo de medición preciso que se utiliza con un dispositivo óptico.

**Escala lineal:** cuando está en uso, si la conexión entre la

La escala lineal y la lectura digital están rotas o dañadas.

externamente, pueden producirse valores de medición incorrectos. Por lo tanto,

El usuario debe tener cuidado.



No intente reparar ni modificar la lectura digital, de lo contrario, podría producirse una falla.

Puede producirse una avería o lesión. En caso de cualquier condición anormal,

Por favor, póngase en contacto con la empresa o el distribuidor.



Si la escala lineal óptica utilizada con la lectura digital está dañada, no utilice una escala lineal de otra marca. Debido a que el rendimiento, las especificaciones y la conexión de los productos de diferentes marcas pueden

No se conectará sin la instrucción de un técnico especializado.

personal, de lo contrario, se producirán problemas en la lectura digital.



**With the continuous updating of products, if there are changes or**

En caso de cambios en los parámetros de muestra, prevalecerán los archivos aleatorios y la empresa tendrá el derecho de interpretación final sin previo aviso.

## Contents

---

1.	Illustration of Panel and keyboard .....	4
2.	Caption of the keyboard .....	5
3.	Parameters settings .....	7
3.1	Parameters setup routine entrance .....	7
3.2	Parameters Settings Description .....	7
3.2.1	Setting the Resolution .....	7
3.2.2	Setting Positive Direction for Counter .....	8
3.2.3	Toggle Between R/D Display Mode .....	8
3.2.4	Setting Z axis Dial .....	8
3.2.5	Setting the Rotary Radius of the Workpiece.....	9
3.2.6	Setting the Angle Display Mode .....	9
3.2.7	Setting the Baudrate of RS_232(optional) .....	9
3.2.8	Setting the Absolute Zeroing enable or disable .....	10
3.2.9	Setting the Absolute form the Special Function .....	10
3.2.10	Setting the Calculator display Mode.....	10
3.2.11	display brightness setting .....	10
3.2.12	The linear scale counting frequency setting .....	11
3.2.13	Setting QUIT .....	11
3.2.14	Setting the type of the DRO. ....	11
3.2.15	Signal Interface Type .....	11
3.2.16	Restore Factory Settings: .....	12
3.2.17	Shrinkage Ratio enable or disable.....	12
3.2.18	Setting Compensation Type .....	12
3.2.19	Inch display, set the number of digits after the decimal point...	13
3.2.20	Setting EDM(optional) .....	13
3.2.21	Setting Linearity Compensation. ....	13
3.2.22	Setting the Shrinkage Ratio .....	13
4.	General Operations .....	14
4.1	Zeroing.....	14
4.2	Preset Data to Designated Axis .....	14
4.3	Toggle Display Unit between inch and mm .....	14
4.4	Absolute/Incremental/200 groups SDM .....	15
4.5	1/2 Function .....	15
4.6	Clear All SDM Datum.....	16

## Contents

---

4.7 Sleeping Mode .....	16
4.8 Power Interruption Memory .....	16
4.9 Search the Absolute Reference Point of Scale .....	17
4.10 Non Linear Error Compensation .....	20
5、200 Groups SDM coordinate .....	21
5.1 Zeroing at the Current Point.....	21
5.2 Preset datum of SDM coordinate .....	22
6、Special Function.....	24
6.1 Circumference Holes Processing .....	25
6.2 Linear Holes Processing .....	28
6.3 ARC Processing .....	30
6.4 Oblique Processing .....	39
6.5 Slope Processng.....	43
6.6 Chamber Processing.....	44
6.7 The Tool Diameter Compensation Function .....	45
6.8 Digital Filter of the Grinding Machine .....	46
6.9 Lathe Function .....	47
6.9.1 200 sets TOOL Libs .....	47
6.9.2 Taper Function .....	48
6.9.3 R/D Function .....	49
6.9.4 Y + Z Function ( only applicable to : 3 axes Lathe).....	49
6.10 EDM.....	50
7、Calculator.....	56
8、Appendix .....	57

## Illustration of Panel and keyboard

## THREE AXIS PANEL

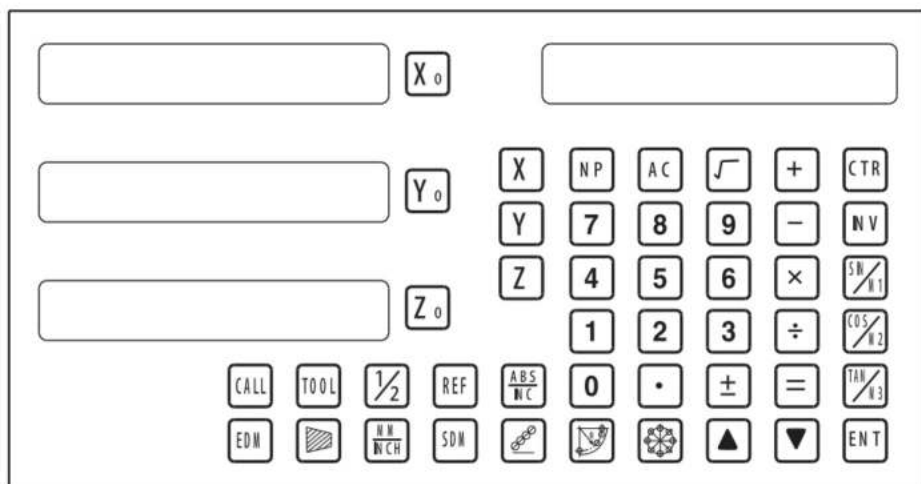



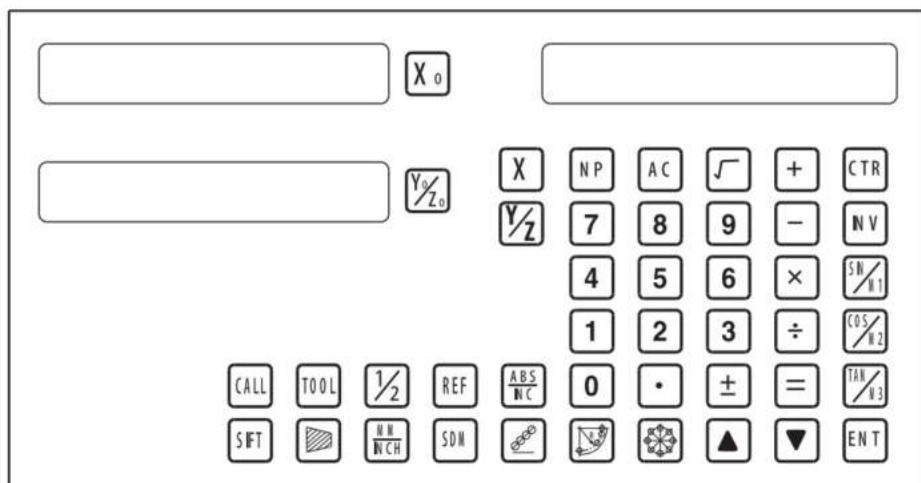









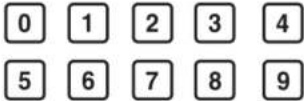



## TWO AXIS PANEL















## Caption of the keyboard

## Keyboard Description

	Keys for axis selection
	Zero select axis
	Enter +/- sign
	Enter decimal point
	Entry keys for numbers
	Operation key (in Calculation function key)
	Enter or quit calculating state
	Cancel incorrect operation
	Calculate inverse trigonometric
	Square root
	Confirm operation
	Toggles between inch and millimeter units.
	Press when ready to identify a reference mark.
	Function keys for 200 sub datum
	ARC cutting function
	holes displayed equally on a circle
	holes displayed equally on a line

## Caption of the keyboard

	Calculate trigonometric or Slope Processing function key
	Calculate trigonometric or rectangular inner chamber processing function key
	Calculate trigonometric or the tool diameter compensation function key
	Toggle between ABS/INC coordinate
	Stroll up or down to select
	Taper measured function key
	Tool library call key
	Opens the tool table.( lathe)
	EDM function key
	Filter display function key
	Half a display value of an axis
	Non Linear Error Compensation function keys

## Parameters settings

## 3. Parameters settings

## 3.1 Parameters setup routine entrance.

Press  $\square \bullet$  to enter initial system and self-check after DRO powers on in 1 second, then Parameters settings display in the Parameters window. press  $\blacktriangle$   $\blacktriangledown$  to select the item you want to change.

If you want to quit initial setting, press  $\blacktriangle$   $\blacktriangledown$  until "QUIT" appears in message window and press  $\square \text{ENT}$ . You can also press  $\square \bullet$  to quit initial setting.

## 3.2 Parameters Settings Description

## 3.2.1 Setting the Resolution

Press  $\blacktriangle$   $\blacktriangledown$  until "RESOLUTE" appears in message window;

When selecting the LINEAR encode, the resolution will be set as follow:

There are 19 types of resolution:

0.01um;0.02um;0.05um;0.10um;0.20um;0.25um;0.50um;1.00um;2.00um;2.50um;5.00um;10.00um;20.00um;25.00um;50.00um;100.00um;200.00um;250.00um;500.00um.

Press  $\square X_0$  to change the resolution for X axis; Press  $\square Y_0$  to change the resolution for Y axis; Press  $\square Z_0$  to change the resolution for Z axis;

Set the resolution 5.00um to 1.00um for X axis:

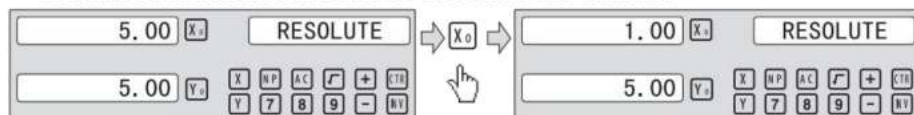

When selecting the rotary encode, the resolution will be set as follow:

Input the rotary encode parameter value .

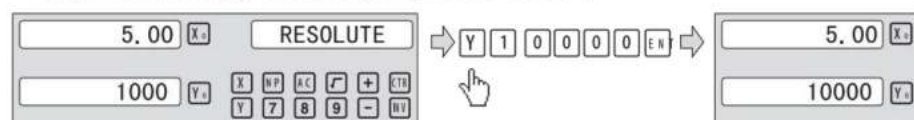

## Parameters settings

## 3.2.2 Setting Positive Direction for Counter

Press  $\blacktriangle$   $\blacktriangledown$  until “DIRECTE” appears in message window.

Direction ‘0’ means the display value will increase when scale moves from right to left and decrease when scale moves from left to right. Direction ‘1’ means the display value will increase when scale moves from left to right and decrease when scale moves from right to left.

Press  $X_0$  to change the Direction for X axis; Press  $Y_0$  to change the Direction for Y axis; Press  $Z_0$  to change the Direction for Z axis; as follow:

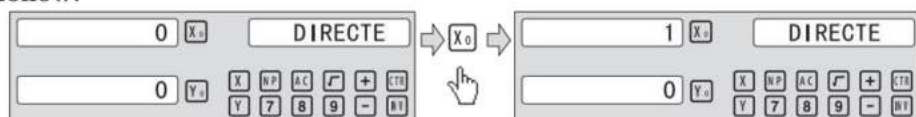

## 3.2.3 Toggle Between R/D Display Mode

Press  $\blacktriangle$   $\blacktriangledown$  until “R OR D” appears in message window. X window, Y window, Z window displays ‘0’ or ‘1’ separately.

‘0’ is mode R, which means the display value equals the actual measurement. ‘1’ is mode D where the display value equals the double actual measurement. Press  $X_0$  to change the R/D for X axis; Press  $Y_0$  to change the R/D for Y axis; Press  $Z_0$  to change the R/D for Z axis; as follow:

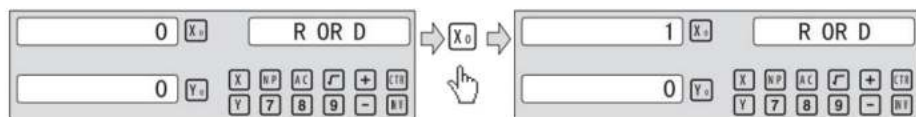

## 3.2.4 Setting Z axis Dial

Press  $\blacktriangle$   $\blacktriangledown$  until “Z DIAL” appears in message window.

Z axis dial should be set if Z axis is emulated for 2 axis milling and only install linear scale for X,Y axis. Z axis dial means the distance the Z axis travels when screw runs a revolution.

## Parameters settings

Set the Z axis Dial 2.5mm as follow ;



### 3.2.5 Setting the Rotary Radius of the Workpiece

Press  $\blacktriangle$   $\blacktriangledown$  until “RDIUS” appears in message window.

The Rotary radius type is used perimeter to measure angle.

Input the Rotary Radius parameter value 2000mm as follow:

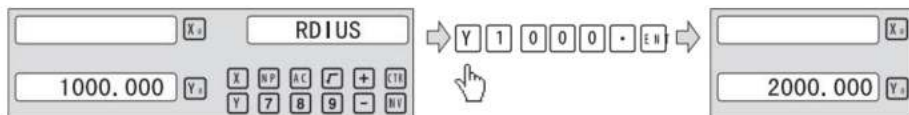

### 3.2.6 Setting the Angle Display Mode

Press  $\blacktriangle$   $\blacktriangledown$  until “ANG DISP” appears in message window.

Press  $X_0$  to change the angle display mode for X axis; Press  $Y_0$  to change the angle display mode for Y axis; Press  $Z_0$  to change the angle display mode for Z axis; Example for X axis:

“0.0000” means the angle mode is Circulating DD;

“0000.0000” means the angle mode is Incremental DD;

“0.00.00” means the angle mode is Circulating DMS;

“0000.00.00” means the angle mode is Incremental DMS;

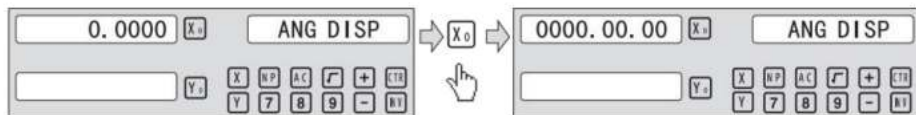



### 3.2.7 Setting the Baudrate of RS\_232 (Special customization function, if you need to buy, please contact the dealer to customize)

Press  $\blacktriangle$   $\blacktriangledown$  until “BAUDRATE” appears in message window.

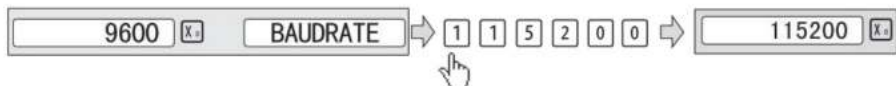

Set the Baudrate 115200 as follow ;



## 3.2.8 Configuración de la habilitación o deshabilitación de la puesta a cero absoluta



presione   hasta que aparezca "ABS CERO" en la ventana de mensajes  
el significa que la operación de puesta a cero del ABS y los datos preestablecidos serán habilitar en el estado de visualización normal

' 1 ' significa que la operación de puesta a cero del ABS y los datos preestablecidos serán Deshabilitar en el estado de visualización normal

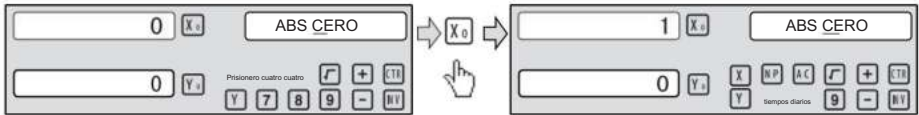
Presione  Para cambiar el modo de puesta a cero absoluta del eje x, presione  para cambiar el modo de puesta a cero absoluta para el eje Y, presione  a cambiar el modo de puesta a cero absoluta para el eje Z; Ejemplo para el eje x :



## 3.2.9 configuración de la forma absoluta de la función especial



presione   hasta que aparezca "ABS ASST" en la ventana de mensajes  
'o' significa que solo se muestra el valor de la posición de la función especial  
Operación de función especial.

' 1 ' significa valor de posición de función especial + valor de posición ABS es mostrar en la operación de Función especial.

presione  para cambiar el modo absoluto de la Función especial será

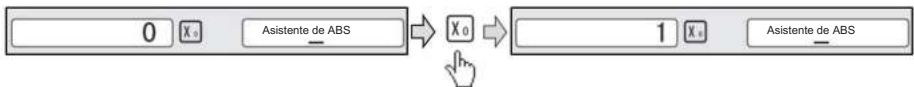
se establecerá de la siguiente manera:

3.2.10 configuración de la **Calculator** Modo de visualización

presione   hasta que aparezca "UCCTR MODE" en el mensaje W · window  
el mensaje que muestra la calculadora en el viento x significa el valor que display;  
' 1 ' muestra la calculadora en la ventana de mensajes en la pantalla;  
presione  Para cambiar el modo de visualización de la calculadora se establecerá AS follow;

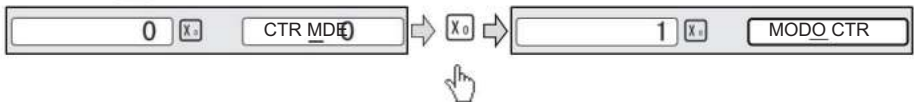

## 3.2.11 Ajuste del brillo de la pantalla

Configuración de brillo de la pantalla LED, la configuración predeterminada de fábrica es solo "3", cuanto mayor sea el parámetro, más brillante será el brillo. Presione "x0" para conjunto, no se recomienda que usted mismo establezca el valor predeterminado.

## Parameters settings

## 3.2.12 The linear scale counting frequency setting

The factory default setting is only "12", the higher the parameter, the lower the counting frequency, press "X0" to set, it is not recommended that you set the default value yourself.

## 3.2.13 Setting QUIT: Digital display table parameters quit button.

## 3.2.14 Setting the type of the DRO.

The type of the DRO will be display on the right window. then press the key **ENT** to select the correct type. the following system item will be set:

"MILL-3" means the DRO type is 3-axis milling machine table;

"MILL-2" means the DRO type is 2-axis milling machine table;

"LATHE-2" means the DRO type is 2-axis lathe table;

"LATHE-3" means the DRO type is 3-axis lathe table;

"GRIND" means the DRO type is Grind table;

"EDM" means the DRO type is EDM table; (Special customization function, if you need to buy, please contact the dealer to customize)

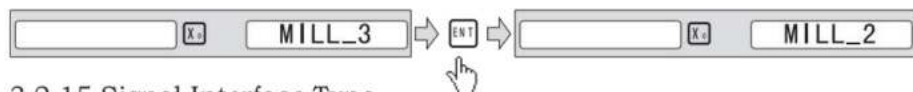

## 3.2.15 Signal Interface Type

Message window displays "SEL AXIS" which indicates the step is to Sensor input signal mode. Press **X0** to change the signal mode for X axis; Press **Y0** to change the signal mode for Y axis; Press **Z0** to change the signal mode for Z axis; Example for X axis:

Press **X0** to scroll through the Rotary encode type, the Linear encode type, the Rotary rdius type.

X window displays the Signal type.

"LInER" means the Signal type is linear encode type ;

"EnCoDE " means the Signal type is Rotary encode type;

"RdIUS" means the Signal type is Rotary rdius type ;

Example: currently in the linear encode type, to toggle to the Rotary encode type;

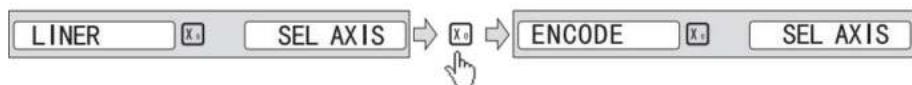

## Parameters settings

## 3.2.16 Restore Factory Settings:

Clear all data except DRO type. DRO will load default setup for parameter. After loading default setup, user must search RI once to enable resuming ABS datum function; otherwise to resume the datum by RI is unable;

Message window displays “ALL CLR”, press **ENT** and message windows display “PASSWORD” indicating the operator to input password; Press 2000 + **ENT** in turn to load default value;

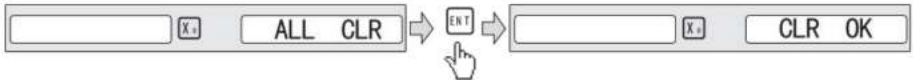

## 3.2.17 Shrinkage Ratio enable or disable.

Message window displays “SRK OFF” to disable Shrinkage rate function. Press **ENT** to enable Shrinkage rate function in Message window displays “SRK ON” :

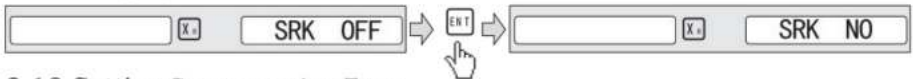

## 3.2.18 Setting Compensation Type

Message window displays “SEL COMP” which indicates the step is to compensation type. Press **X0** to change the compensation type for X axis; Press **Y0** to change the compensation type for Y axis; Press **Z0** to change the compensation type for Z axis; Example for X axis:

Press **X0** to scroll through the not compensation type, the Linear compensation type, the non-linear compensation type.

“no-CO” means the compensation type is not compensation type;

“LinE-CO” means the compensation type is linear compensation type.

“non-LinE” means the compensation type is non-linear linear compensation type;

Example for X axis: currently in the not compensation type, to toggle to the linear compensation type;

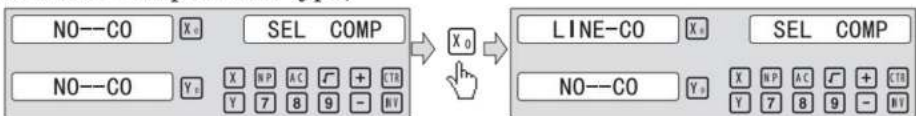

## Parameters settings

## 3.2.19 Inch display, set the number of digits after the decimal point

In the inch display mode, the number of digits after the decimal point is set, the factory default digit is "4", press "X0" to set, can be set according to actual needs.

3.2.20 Setting EDM: it is not recommended that you set the default value yourself, EDM function, Set the relay off on time.

## 3.2.21 Setting Linearity Compensation.

Message window displays "LIN COMP" which indicates the step is to Linearity Compensation. Compensate the linear error to make display value equals to standard value.

The calculation of compensation rectifying coefficient:

$$\text{Coefficient} = \frac{(\text{Measurement} - \text{Standard value}) \times 1000.000}{\text{Standard value}}$$

Example for X axis:

Measurement 200.020mm

Standard value 200.000mm

Rectifying coefficient= (200.020-200) \* 1000 /200 =-0.01mm/m

Input compensation rectifying coefficient 0.01 as follow:

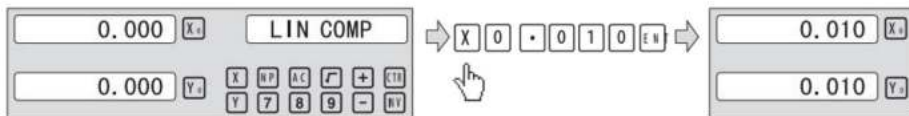

## 3.2.22 Setting the Shrinkage Ratio

Press until "SHRINK" appears in message window;

$$\text{Shrinkage ratio} = \frac{\text{Dimensions of the finished product}}{\text{Dimensions of the working piece}}$$

Set the shrinkage ratio 1.005 as follow;

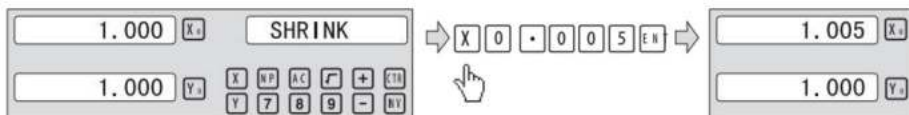







## General Operations

---

### 4、 General Operations;

#### 4.1 Zeroing



Zero the designated axis in normal display state. Zeroing is used to set the current position as datum point as follow;

key		<span style="border: 1px solid black; padding: 2px;">X<sub>0</sub></span>		X axis zero	<table style="width: 100%; border-collapse: collapse;"> <tr> <td style="width: 80%; border: 1px solid gray; padding: 2px;">0.000</td> <td style="width: 20%; border: 1px solid gray; padding: 2px;"><span style="border: 1px solid black; padding: 2px;">X<sub>0</sub></span></td> </tr> <tr> <td style="border: 1px solid gray; padding: 2px;">0.000</td> <td style="border: 1px solid gray; padding: 2px;"><span style="border: 1px solid black; padding: 2px;">Y<sub>0</sub></span></td> </tr> <tr> <td style="border: 1px solid gray; padding: 2px;">0.000</td> <td style="border: 1px solid gray; padding: 2px;"><span style="border: 1px solid black; padding: 2px;">Z<sub>0</sub></span></td> </tr> </table>	0.000	<span style="border: 1px solid black; padding: 2px;">X<sub>0</sub></span>	0.000	<span style="border: 1px solid black; padding: 2px;">Y<sub>0</sub></span>	0.000	<span style="border: 1px solid black; padding: 2px;">Z<sub>0</sub></span>
0.000	<span style="border: 1px solid black; padding: 2px;">X<sub>0</sub></span>										
0.000	<span style="border: 1px solid black; padding: 2px;">Y<sub>0</sub></span>										
0.000	<span style="border: 1px solid black; padding: 2px;">Z<sub>0</sub></span>										
key		<span style="border: 1px solid black; padding: 2px;">Y<sub>0</sub></span>		Y axis zero							
key		<span style="border: 1px solid black; padding: 2px;">Z<sub>0</sub></span>		Z axis zero							

X<sub>0</sub> or Y<sub>0</sub> or Z<sub>0</sub> will be return to the original data before the reset.

#### 4.2 Preset Data to Designated Axis





Preset a value to current position for a designated axis in normal display state.

<table style="width: 100%; border-collapse: collapse;"> <tr><td style="border: 1px solid gray; padding: 2px;">25.400</td><td style="border: 1px solid gray; padding: 2px;"><span style="border: 1px solid black; padding: 2px;">X<sub>0</sub></span></td></tr> <tr><td style="border: 1px solid gray; padding: 2px;">50.800</td><td style="border: 1px solid gray; padding: 2px;"><span style="border: 1px solid black; padding: 2px;">Y<sub>0</sub></span></td></tr> <tr><td style="border: 1px solid gray; padding: 2px;">76.200</td><td style="border: 1px solid gray; padding: 2px;"><span style="border: 1px solid black; padding: 2px;">Z<sub>0</sub></span></td></tr> </table>	25.400	<span style="border: 1px solid black; padding: 2px;">X<sub>0</sub></span>	50.800	<span style="border: 1px solid black; padding: 2px;">Y<sub>0</sub></span>	76.200	<span style="border: 1px solid black; padding: 2px;">Z<sub>0</sub></span>			<table style="width: 100%; border-collapse: collapse;"> <tr><td style="border: 1px solid gray; padding: 2px;">X</td><td style="border: 1px solid gray; padding: 2px;">1</td><td style="border: 1px solid gray; padding: 2px;">8</td><td style="border: 1px solid gray; padding: 2px;">0</td><td style="border: 1px solid gray; padding: 2px;">.</td><td style="border: 1px solid gray; padding: 2px;">0</td><td style="border: 1px solid gray; padding: 2px;">1</td><td style="border: 1px solid gray; padding: 2px;">0</td><td style="border: 1px solid gray; padding: 2px;">ENT</td></tr> <tr><td style="border: 1px solid gray; padding: 2px;">Y</td><td style="border: 1px solid gray; padding: 2px;">5</td><td style="border: 1px solid gray; padding: 2px;">8</td><td style="border: 1px solid gray; padding: 2px;">6</td><td style="border: 1px solid gray; padding: 2px;">.</td><td style="border: 1px solid gray; padding: 2px;">0</td><td style="border: 1px solid gray; padding: 2px;">1</td><td style="border: 1px solid gray; padding: 2px;">0</td><td style="border: 1px solid gray; padding: 2px;">ENT</td></tr> <tr><td style="border: 1px solid gray; padding: 2px;">Z</td><td style="border: 1px solid gray; padding: 2px;">8</td><td style="border: 1px solid gray; padding: 2px;">8</td><td style="border: 1px solid gray; padding: 2px;">8</td><td style="border: 1px solid gray; padding: 2px;">.</td><td style="border: 1px solid gray; padding: 2px;">6</td><td style="border: 1px solid gray; padding: 2px;">6</td><td style="border: 1px solid gray; padding: 2px;">0</td><td style="border: 1px solid gray; padding: 2px;">ENT</td></tr> </table>	X	1	8	0	.	0	1	0	ENT	Y	5	8	6	.	0	1	0	ENT	Z	8	8	8	.	6	6	0	ENT		<table style="width: 100%; border-collapse: collapse;"> <tr><td style="border: 1px solid gray; padding: 2px;">180.010</td><td style="border: 1px solid gray; padding: 2px;"><span style="border: 1px solid black; padding: 2px;">X<sub>0</sub></span></td></tr> <tr><td style="border: 1px solid gray; padding: 2px;">586.010</td><td style="border: 1px solid gray; padding: 2px;"><span style="border: 1px solid black; padding: 2px;">Y<sub>0</sub></span></td></tr> <tr><td style="border: 1px solid gray; padding: 2px;">888.660</td><td style="border: 1px solid gray; padding: 2px;"><span style="border: 1px solid black; padding: 2px;">Z<sub>0</sub></span></td></tr> </table>	180.010	<span style="border: 1px solid black; padding: 2px;">X<sub>0</sub></span>	586.010	<span style="border: 1px solid black; padding: 2px;">Y<sub>0</sub></span>	888.660	<span style="border: 1px solid black; padding: 2px;">Z<sub>0</sub></span>
25.400	<span style="border: 1px solid black; padding: 2px;">X<sub>0</sub></span>																																											
50.800	<span style="border: 1px solid black; padding: 2px;">Y<sub>0</sub></span>																																											
76.200	<span style="border: 1px solid black; padding: 2px;">Z<sub>0</sub></span>																																											
X	1	8	0	.	0	1	0	ENT																																				
Y	5	8	6	.	0	1	0	ENT																																				
Z	8	8	8	.	6	6	0	ENT																																				
180.010	<span style="border: 1px solid black; padding: 2px;">X<sub>0</sub></span>																																											
586.010	<span style="border: 1px solid black; padding: 2px;">Y<sub>0</sub></span>																																											
888.660	<span style="border: 1px solid black; padding: 2px;">Z<sub>0</sub></span>																																											





#### 4.3 Toggle Display Unit between inch and mm

Length can be displayed either in “mm” (metric) or “inch” (imperial). Display unit can be toggled between mm and inch.

Example: Display value toggle from mm to inch;

<table style="width: 100%; border-collapse: collapse;"> <tr><td style="border: 1px solid gray; padding: 2px;">25.400</td><td style="border: 1px solid gray; padding: 2px;"><span style="border: 1px solid black; padding: 2px;">X<sub>0</sub></span></td></tr> <tr><td style="border: 1px solid gray; padding: 2px;">50.800</td><td style="border: 1px solid gray; padding: 2px;"><span style="border: 1px solid black; padding: 2px;">Y<sub>0</sub></span></td></tr> <tr><td style="border: 1px solid gray; padding: 2px;">76.200</td><td style="border: 1px solid gray; padding: 2px;"><span style="border: 1px solid black; padding: 2px;">Z<sub>0</sub></span></td></tr> </table>	25.400	<span style="border: 1px solid black; padding: 2px;">X<sub>0</sub></span>	50.800	<span style="border: 1px solid black; padding: 2px;">Y<sub>0</sub></span>	76.200	<span style="border: 1px solid black; padding: 2px;">Z<sub>0</sub></span>	mm 			inch 	<table style="width: 100%; border-collapse: collapse;"> <tr><td style="border: 1px solid gray; padding: 2px;">1.0000</td><td style="border: 1px solid gray; padding: 2px;"><span style="border: 1px solid black; padding: 2px;">X<sub>0</sub></span></td></tr> <tr><td style="border: 1px solid gray; padding: 2px;">2.0000</td><td style="border: 1px solid gray; padding: 2px;"><span style="border: 1px solid black; padding: 2px;">Y<sub>0</sub></span></td></tr> <tr><td style="border: 1px solid gray; padding: 2px;">3.0000</td><td style="border: 1px solid gray; padding: 2px;"><span style="border: 1px solid black; padding: 2px;">Z<sub>0</sub></span></td></tr> </table>	1.0000	<span style="border: 1px solid black; padding: 2px;">X<sub>0</sub></span>	2.0000	<span style="border: 1px solid black; padding: 2px;">Y<sub>0</sub></span>	3.0000	<span style="border: 1px solid black; padding: 2px;">Z<sub>0</sub></span>
25.400	<span style="border: 1px solid black; padding: 2px;">X<sub>0</sub></span>																
50.800	<span style="border: 1px solid black; padding: 2px;">Y<sub>0</sub></span>																
76.200	<span style="border: 1px solid black; padding: 2px;">Z<sub>0</sub></span>																
1.0000	<span style="border: 1px solid black; padding: 2px;">X<sub>0</sub></span>																
2.0000	<span style="border: 1px solid black; padding: 2px;">Y<sub>0</sub></span>																
3.0000	<span style="border: 1px solid black; padding: 2px;">Z<sub>0</sub></span>																

Example: Display value toggle from inch to mm;

<table style="width: 100%; border-collapse: collapse;"> <tr><td style="border: 1px solid gray; padding: 2px;">1.0000</td><td style="border: 1px solid gray; padding: 2px;"><span style="border: 1px solid black; padding: 2px;">X<sub>0</sub></span></td></tr> <tr><td style="border: 1px solid gray; padding: 2px;">2.0000</td><td style="border: 1px solid gray; padding: 2px;"><span style="border: 1px solid black; padding: 2px;">Y<sub>0</sub></span></td></tr> <tr><td style="border: 1px solid gray; padding: 2px;">3.0000</td><td style="border: 1px solid gray; padding: 2px;"><span style="border: 1px solid black; padding: 2px;">Z<sub>0</sub></span></td></tr> </table>	1.0000	<span style="border: 1px solid black; padding: 2px;">X<sub>0</sub></span>	2.0000	<span style="border: 1px solid black; padding: 2px;">Y<sub>0</sub></span>	3.0000	<span style="border: 1px solid black; padding: 2px;">Z<sub>0</sub></span>	inch 			mm 	<table style="width: 100%; border-collapse: collapse;"> <tr><td style="border: 1px solid gray; padding: 2px;">25.400</td><td style="border: 1px solid gray; padding: 2px;"><span style="border: 1px solid black; padding: 2px;">X<sub>0</sub></span></td></tr> <tr><td style="border: 1px solid gray; padding: 2px;">50.800</td><td style="border: 1px solid gray; padding: 2px;"><span style="border: 1px solid black; padding: 2px;">Y<sub>0</sub></span></td></tr> <tr><td style="border: 1px solid gray; padding: 2px;">76.200</td><td style="border: 1px solid gray; padding: 2px;"><span style="border: 1px solid black; padding: 2px;">Z<sub>0</sub></span></td></tr> </table>	25.400	<span style="border: 1px solid black; padding: 2px;">X<sub>0</sub></span>	50.800	<span style="border: 1px solid black; padding: 2px;">Y<sub>0</sub></span>	76.200	<span style="border: 1px solid black; padding: 2px;">Z<sub>0</sub></span>
1.0000	<span style="border: 1px solid black; padding: 2px;">X<sub>0</sub></span>																
2.0000	<span style="border: 1px solid black; padding: 2px;">Y<sub>0</sub></span>																
3.0000	<span style="border: 1px solid black; padding: 2px;">Z<sub>0</sub></span>																
25.400	<span style="border: 1px solid black; padding: 2px;">X<sub>0</sub></span>																
50.800	<span style="border: 1px solid black; padding: 2px;">Y<sub>0</sub></span>																
76.200	<span style="border: 1px solid black; padding: 2px;">Z<sub>0</sub></span>																

## General Operations

### 4.4 Absolute/Incremental/200 groups SDM

Function: The DRO has 3 coordinate display modes: the absolute mode (ABS); the incremental mode (INC) and 200 groups Second Data Memory (SDM) with the range of 00 to 99. Zero point of work-piece is set at the origin point of ABS coordinate. The relative distance between datum of ABS and SDM remains unchanged when ABS datum is changed.

1. Toggle from ABS to INC coordinate;

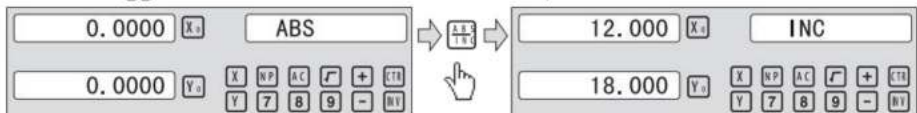

2. Toggle from INC to ABS coordinate;

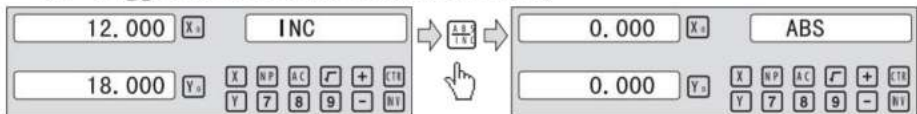

3. Toggle from SMD to ABS coordinate;



### 4.5 1/2 Function

Function: Set the center of work piece as datum by halving the displayed value.

Example: Set the center of rectangle as datum as the right figure.

Steps:

1. Touch one side of the workpiece with the TOOL, then zero the X axis.

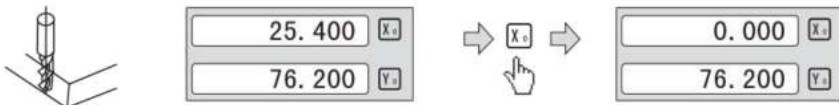

2 Lleve la HERRAMIENTA al lado opuesto de la pieza de trabajo y tóquela.

Luego presione  +  a su vez para valorar el valor de visualización del eje X.

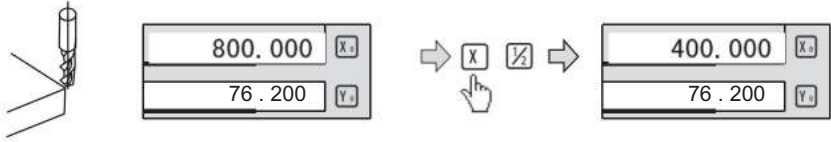

3. Mueva la mesa de mecanizado hasta que se muestre "0.000" en el eje x. ventana. La posición es el centro de la pieza de trabajo.

4. 6 Borrar todos los datos SDM.

En modo ABS, presionar continuamente



Diez veces harán que se aclare

Todos los datos para 200 conjuntos SDM. La ventana de mensajes muestra USDM "CLR" .

4.7 Modo de suspensión

en modo no ABS, pulsando la tecla



Puede apagar toda la pantalla

y el DRO accediendo al modo de reposo, luego presionando esta tecla

nuevamente hará que el DRO vuelva al modo de trabajo. En el modo de suspensión

El modo DRO todavía está en estado de funcionamiento y realmente registra la HERRAMIENTA

**movement.**

Ejemplo: En modo no ABS, para acceder al modo sleepin8 presione

la tecla F. En  el modo de suspensión, al pulsar la tecla F se sale del modo

Modo dormir ·

4. 8 Memoria de interrupción de energía.

La memoria se utiliza para almacenar las configuraciones del DRO y de la máquina.

Valores de referencia cuando se apaga la alimentación.

#### 4. 9 Busque el punto de referencia absoluto de la escala

Durante el proceso de mecanizado diario, es muy común que el

El mecanizado no se puede completar en un turno de trabajo, por lo que

El DRO debe apagarse después del trabajo o puede ocurrir un corte de energía durante el mismo.

El proceso de mecanizado que conduce a la pérdida de los datos de la pieza de trabajo.

(posición cero de la pieza de trabajo), el restablecimiento del punto de referencia de la pieza de trabajo

El uso de un detector de bordes u otro método inevitablemente induce una mayor

mecanizado con precisión porque no es posible restablecer la

punto de referencia de la pieza de trabajo exactamente en la posición anterior. PARA permitir que

recuperación de los datos de la pieza de trabajo con gran precisión y sin necesidad de

restablecer los datos de la pieza de trabajo utilizando un detector de bordes u otros métodos,

Cada escala lineal tiene una ubicación de punto de referencia que está equipada con referencia

posición para proporcionar la función de memoria del punto de referencia.

El principio de funcionamiento de la función de memoria de datos de referencia es el siguiente:  
Sigue.

Dado que el punto de referencia de la escala lineal es permanente y fijo,

nunca cambian ni desaparecen cuando el sistema DRO está apagado.

Por lo tanto, simplemente necesitamos almacenar la distancia entre el punto de referencia

y el dato de la pieza de trabajo (posición cero) en la memoria NO volátil. Luego

En caso de corte de energía o de que se apague el DRO, podemos recuperarlo.

el punto de referencia de la pieza de trabajo (posición cero) mediante el preajuste del cero de la pantalla

posición como la distancia almacenada desde el punto de referencia ·

Se debe establecer un dato absoluto cuando se mecaniza una pieza de trabajo.

Hay tres modos de funcionamiento (REF, AB, LEF AB):

Ejemplo: para almacenar el dato de trabajo del eje X

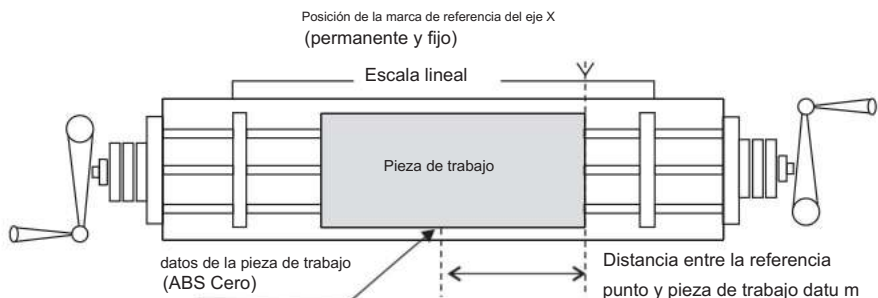

## General Operations

### Example for REF mode :

1、 DRO is set in ABS coordinate. Press **REF** , then the message window display “REF” .

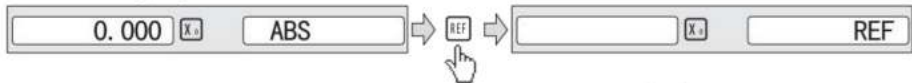

2、 Message window displays “REF” , Press **ENT** until “FD\_REF” appears in message window.

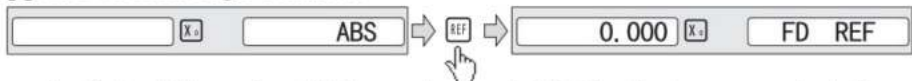

3、 Select the axis which need search RI. For instance : select X axis, then press **X** . “X\_REF” is displayed in message window, and X axis window flashes.

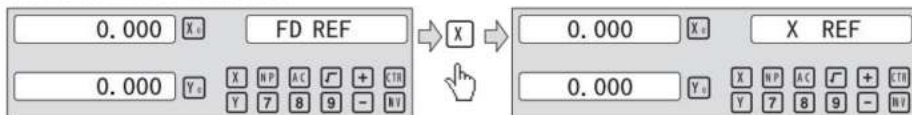

4、 Move the machine table .The buzzer sounds when RI is searched, then X window stops flashing and displays the value of the current position .the DRO returns normal display state. Then message window displays “FIND\_X” .

### Example for AB mode :

1、 DRO is set in ABS coordinate. Press **REF** , then the message window display “REF” .

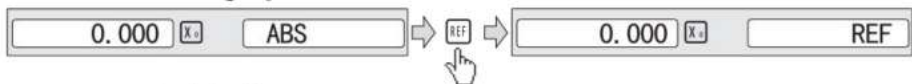

2、 Press **▲ ▼** , then the message window display “AB” .



3、 Message window displays “AB” , Press **ENT** until “FIND\_AB” appears in message window.

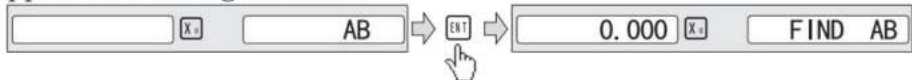

## General Operations

4、 Select the axis which need search RI. For instance : selct X axis, then press **X** . “X\_REF” is displayed in message window, and X axis window flashes.

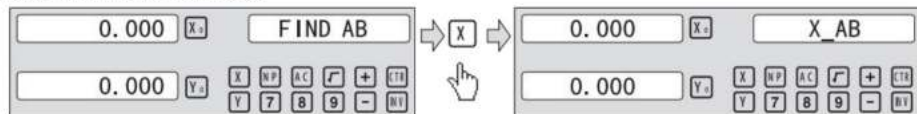

5、 Move the machine table .The buzzer sounds when RI is searched, displays the value of the current position for the absolute datum zero. the DRO returns normal display state. Then message window displays “FIND\_AB” .

### Example for LEF\_AB mode :

1、 DRO is set in ABS coordinate. Press **REF** , then the message window display “REF” .

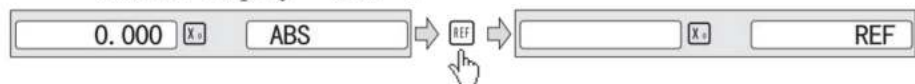

2、 Press **▲** **▼** , then the message window display “AB” .

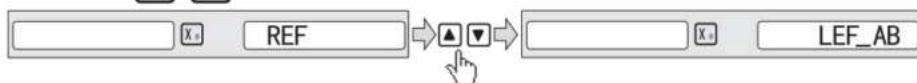

3、 Message window displays “LEF\_AB” , Press **ENT** until “ZERO\_AB” appears in message window.

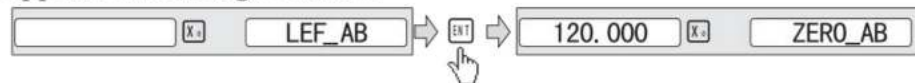

4、 Move the machine table to be set zero position piont. then press **X** , X axis will be zeroing . the current position for the absolute datum zero. the DRO returns normal display state.

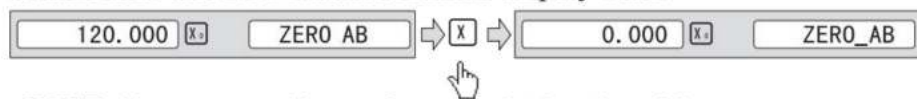

NOTE: Linear range without reference point location of the user

## General Operations

### 4.10 Non Linear Error Compensation

First compensation Type ( Linear or Non-Linear) in parameter setting must be set Non-Linear. Linear scale have a ref point location and find to the Absolute Reference Point will be enable.

Default Non-Linear compensation : 50.

#### Example for Y axis:

Step 1: Search the Absolute Reference Point of Scale;

Step 2: Press **[NP]** , then the message window display “COMP X” .



Step 3: Press **[▲]** **[▼]**, then the message window display “COMP Y”



Step 4: Press **[ENT]**, then the message window display “NUMBER” .

Then input the compensation parameter NUMBER.



Step 5: Press **[▲]** **[▼]**, then message window displays “Y-MSN-1” which indicates the step is to Non Linear Error Compensation.

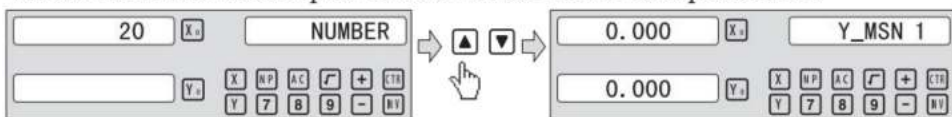

Step 6: Input compensation value .

X window display the value of the measurement value.

Y window display the value of the standard value.

Example for the first compensation point:

Measurement value :68.288mm. Standard value: 68.200mm



Step 7: After input all parameter, the DRO automatically exit.

## 5、 200 Groups SDM coordinate

The DRO has three display modes: the absolute mode (ABS), the incremental mode (INC) and the 200 groups second data memory (SDM 1 – SDM200). ABS datum of the work-piece is set at the beginning and the 200 groups SDM is set relative to ABS coordinate.

ABS Mode, INC Mode and SdM Mode are specially designed to provide much more convenience features to the operator to cope with the batch machining of relative works and the machining of the workpiece machining dimensions from more than one datum.

**Example:** The ABS datum is the center point O, the point sdm1, sdm2, sdm3, sdm4 needed processing are set as datum of SDM 1 – SDM 4.

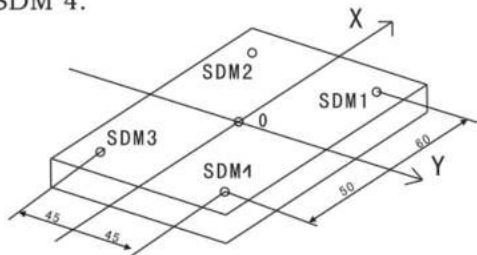

Two ways to set SDM coordinate:

- 1、 Zeroing at the Current Point.
- 2、 Preset datum of SDM coordinate.

### 5.1 Zeroing at the Current Point

At first set the center point of the work-piece as the origin of the ABS, then align the TOOL with point SDM1,SDM2,SDM3,SDM4 by moving the machine table and zero them. It is the position to process where the “0.000” appears in X window, Y window by moving the machine table whether in ABS or in SDM coordinate.

#### Steps:

- 1、 Move worktable to place the TOOL at the center of the workpiece point O as the datum of ABS. Then zero X axis and Y axis in SDM 1 ; Zero X axis and Y axis in SDM 2 ; Zero X axis and Y axis in SDM 3 ; Zero X axis and Y axis in SDM 4.

## 200 Groups SDM coordinate

2、 Set the point sdm1 as the datum of SDM 1. Move the machine worktable to  $x = 60.000$ ,  $y = 45.000$ . Then proess  $X_0$   $Y_0$ .

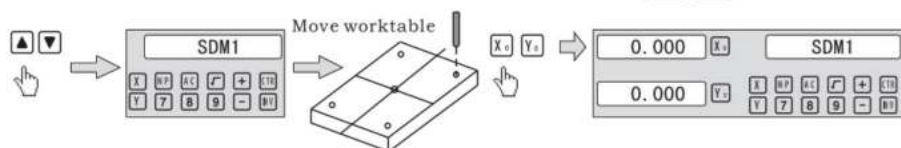

2、 Set the point sdm1 as the datum of SDM 2. Move the machine worktable to  $x = 60.000$ ,  $y = -45.000$ . Then proess  $X_0$   $Y_0$ .

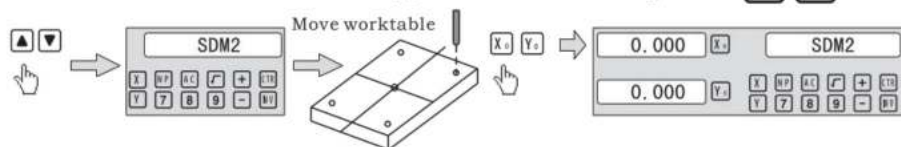

3、 Set the point sdm1 as the datum of SDM 3. Move the machine worktable to  $x = -60.000$ ,  $y = -45.000$ . Then proess  $X_0$   $Y_0$ .

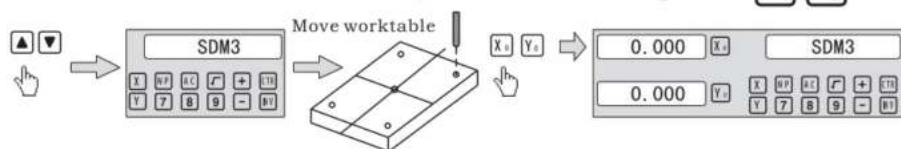

4、 Set the point sdm1 as the datum of SDM 4. Move the machine worktable to  $x = -60.000$ ,  $y = 45.000$ . Then proess  $X_0$   $Y_0$ .

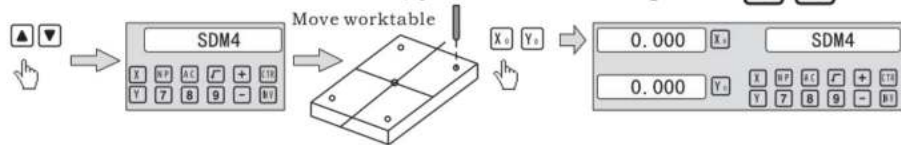

## 5.2 Preset datum of SDM coordinate

There are the same sample as Method 1. First Move the worktable to place the TOOL exactly at the origin of ABS, secondly Enter the ABS Mode as follow.

### Steps:

1、 Move worktable to place the TOOL at the center of the workpiece point O as the datum of ABS. Then zero X axis and Y axis in SDM 1 ; Zero X axis and Y axis in SDM 2 ; Zero X axis and Y axis in SDM 3 ; Zero X axis and Y axis in SDM 4.

## 200 Groups SDM coordinate

2、 Set point sdm1 as the datum of SDM 1. Press  $\blacktriangle$   $\blacktriangledown$ , then the message window display “SDM 1” . Input x = 60.000, y = 45.000.

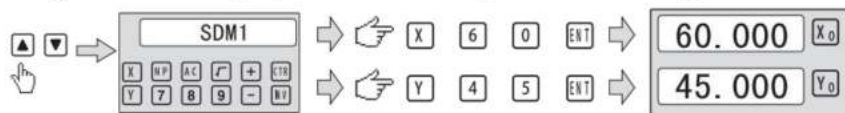

3、 Set point sdm1 as the datum of SDM 2. Press  $\blacktriangle$   $\blacktriangledown$ , then the message window display “SDM 2” . Input x = -60.000, y = 45.000.

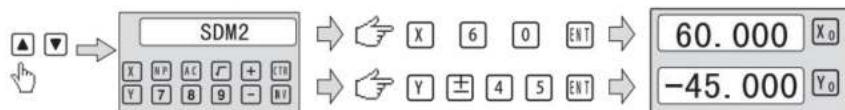

4、 Set point sdm1 as the datum of SDM 3. Press  $\blacktriangle$   $\blacktriangledown$ , then the message window display “SDM 3” . Input x = -60.000, y = -45.000.

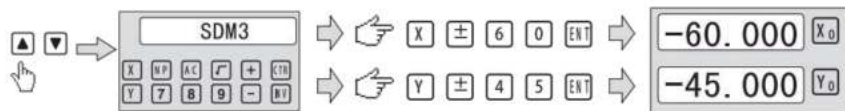

5、 Set point sdm1 as the datum of SDM 4. Press  $\blacktriangle$   $\blacktriangledown$ , then the message window display “SDM 4” . Input x = -60.000, y = 45.000.



## Función especial

---

### 6Función especial

## Circumference Holes Processing

### 6.1 Circumference Holes Processing

The Function of PCD Hole positioning on Circumference is used to distribute arc equally, such as boring hole on flange. The right window will show the parameter to be defined when selecting PCD Function.

The Parameters to be defined are:

PCD_XY(XZ,YZ)	Select place
CENTER	Center position
DIA	Diameter of circle
NO_HOLE	Hole number
ST ANG	Starting angle
ED ANG	Ending angle

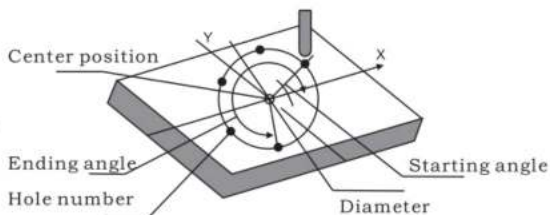

The position of the hole center are calculated automatically after input all parameters. Press or to choose the hole No. and move the machine table until the “0.000” appears in X window , Y window, Z window. It is the position to process a table.

Example for the XY place: Machine hole on circumference as the figure

PCD_XY(XZ,YZ)	XY
CENTER	X=0,000,Y=0.000
DIA	100,000
NO_HOLE	5
ST ANG	30,000
ED ANG	315,000

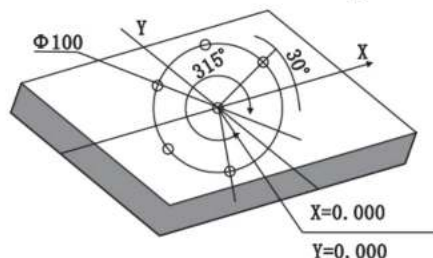

Steps:

1. Set display unit to metric in normal state; Move the machine table until the machine TOOL is aligned with the center of the circle , then zero X axis ,Y axis.

2. Select place.

Press , then the message window display “PCD\_XY” to the Circumference Holes Processing. Press or to select XY place.



## Circumference Holes Processing

## 2. Input center position.

Press **ENT** , then the message window display “CENTER” . X and Y window displays the formerly preset center position. Input X = 0, Y = 0 as follow.

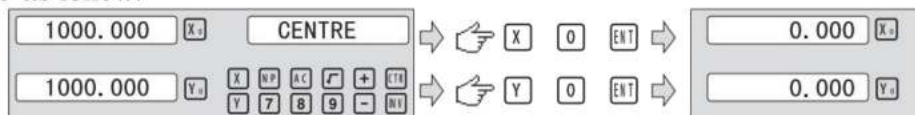

## 4. Input diameter.

Press **▼** until “DIA” appears in the message window. X window displays the formerly preset diameter. Then input the diameter is 100.000.

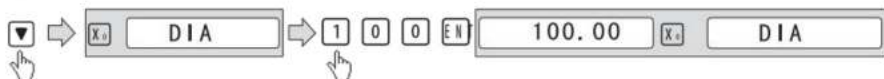

## 5. Input number.

Press **▼** until “NO\_HOLE” appears in the message window. X window displays the formerly preset number. Then press **5** in turn to input number.



## 6. Input starting angle.

Press **▼** until “ST ANG” appears in the message window. X window displays the formerly preset the starting angle. Then press **3** **0** in turn to input the starting angle.



## 7. Input ending angle.

Press **▼** until “ED ANG” appears in the message window. X window displays the formerly preset the ending angle.. Then press **3** **1** **5** in turn to input the ending angle.

## Circumference Holes Processing



8. Press  until “NO 1” appears in the message window.

It is the position of the first hole to punch where the “0.000” is displayed in X window and Y window by moving the machine table.

After finishing the first hole, press  or  to change holes number.

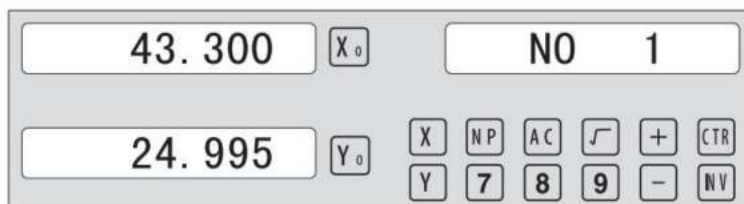

9. After processing all holes, press  to return normal display.

## Linear Holes Processing

### 6.2 Linear Holes Processing

There are two modes to carry out the linear drilling: Length mode and Step mode.

1.LINE S	Step mode
LINE L	Length mode
2.STEP	Step length
LENGTH	Line length
3. ANG	Angle
4. NO.HOLE	Hole number

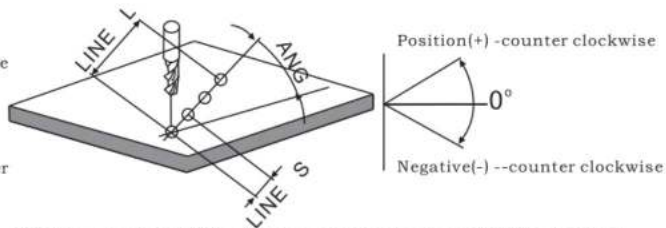

Linear Holes function can simplify the processing multiple holes whose centers are attributed equally on one line.

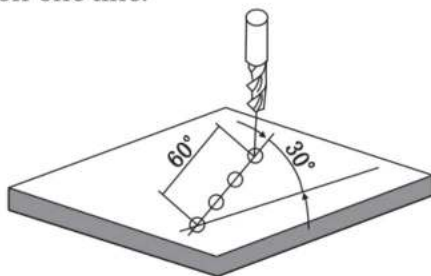

Example :

LINE_L	Length mode
LENGTH	60.000
ANG	30.000
NO.HOLE	4





Steps :

1. Select piece.

Press , then the message window display "LINE\_XY" to the Linear Holes Processing. Press  or  to select XY place.



2. Select Linear Holes mode.

Press , then the message window display "LINE\_S". Press  or  to select "LINE\_L".



3. Input linear length;

Press , then the message window display "LENGTH".

## Linear Holes Processing

X window displays the formerly preset the linear length. Press **6** **0** in turn to input the linear length.



## 4. Input angle;

Message window displays “ANG” which indicates the step is to angle. X window displays the formerly preset the angle. Press **3** **0** in turn to input the angle.

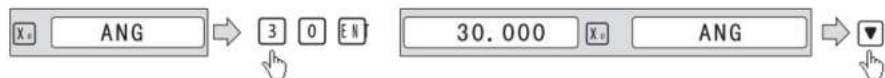

## 5. Input number;

Message window displays “ANG” which indicates the step is to angle. X window displays the formerly preset the number. Press **4** in turn to input the number.

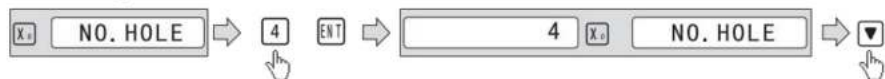

6. Press **▼** until “NO 1” appears in the message window.

It is the position of the first hole to punch where the “0.000” is displayed in X window and Y window by moving the machine table. After finishing the first hole, press **▲** or **▼** to change holes number.

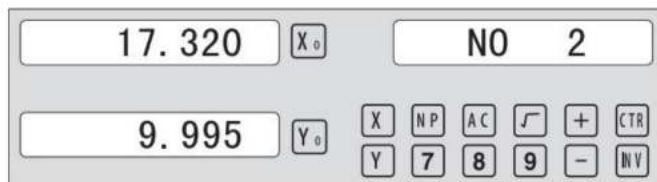

7. After processing all holes, press **☞** to return normal display.

### 6.3 Procesamiento ARC

Hay DOS funciones disponibles para la función ARC: la función ARC simple

Función y la función R suave : presione y luego pr css



para ingresar a la función ARC,



o



para seleccionar la función ARC suave o simple

Función ARC.

Durante la instalación, normalmente las coordenadas de la máquina y la dirección de X, Y, Z son los siguientes. El plano de trabajo se muestra como figura correcta

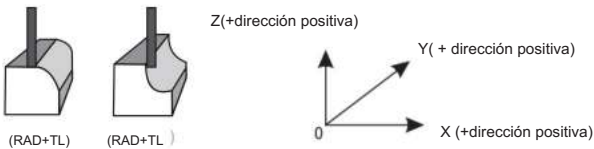

Función ARC simple:

Cuando la suavidad no es muy exigida, el ARCO SIMPLE

La función se utiliza normalmente para mecanizar arcos. En la función SIMPLE

Sólo hay ocho tipos de ARC que se utilizan para mecanizar. El operador simplemente

Seleccione el tipo de R e ingrese los parámetros del radio del arco.

CORTE MÁXIMO y Rrc exterior o arco interior. En general, un arco puede ser

Mecanizado mediante una ranura plana **OOL** O HERRAMIENTA de arco, la diferencia entre T en un plano de trabajo diferente como se muestra a continuación :

- |   |                       |                                  |
|---|-----------------------|----------------------------------|
| 1 | SIMPLE                | procesamiento simple             |
| 2 | TIPO 1 - 8            | Modo del ARC.                    |
| 3 | <b>SEL_XY(XZ, YZ)</b> | Seleccione lugar                 |
| 4 | RAD                   | Radio del arco                   |
| 5 | TL ÉL                 | Diámetro de la herramienta       |
| 6 | CORTE MÁXIMO          | Paso de alimentación             |
| 7 | RAD TL                | arco exterior y<br>arco interior |
- (solo para el lugar xy)

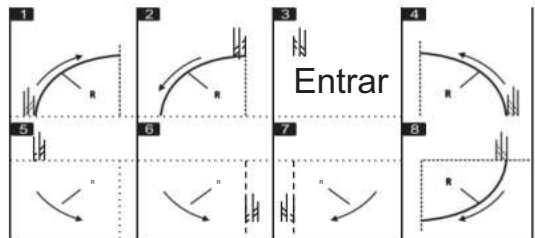

## ARC Processing

---

### Smooth ARC function :

Provides maximum flexibility in ARC machining, the ARC sector to be machined by the coordinates of ARC. Very flexible, ARC function can machine virtually all kinds of ARC, even the intersected ARC. Relatively a bit complicated to operate, operator need to calculate and enter the coordinates of ARC centre, start angle and end angle.

Basic parameter as follow:

1. SMOOTH	Mode of the Smooth ARC processing;
2. SEL_XY(YZ, XZ)	Select place;
3. CENTER	Refer to the position of an center.
4. RAD	Radius of the ARC
5. TL_DIA	Diameter of the TOOL
6. MAX_CUT	Feed step
7. ST_ANG	Starting angle
8. ED_ANG	Ending angle
9. RAD+TL	Outer arc.
RAD-TL	Inner arc.

### Example 1 for the Simple ARC Processing:

Parameters settings as follow:

SIMPLE	Simple mode
TYPE	3
SEL_XY	XY
RAD	80.000
TL_DIA	6.000
MAX_CUT	0.500
RAD+TL	1

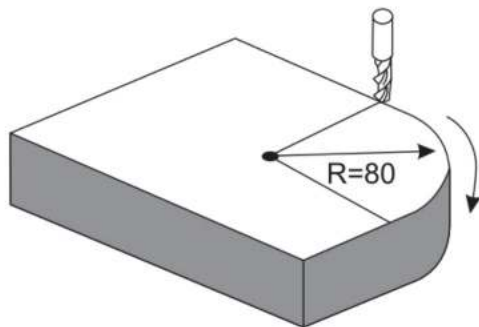

### Steps:

1. Select process mode

Press  , then the message window display “SIMPLE” to the ARC Processing. Press  or  to select mode of the simple, The message window display “SIMPLE”

## ARC Processing



2. Input the type:

Press **ENT** until “TYPE” appears in the message window. X-window displays the formerly preset type. Press **3** in turn



3. Select place

Press **ENT** until “SEL\_XY” appears in the message window.

Press **▲** or **▼** to select place to display “SEL\_XY”;



4. Input radius:

Press **ENT** until “RAD” appears in the message window. X-window displays the formerly preset radius of ARC. Press **80** in turn to input the radius.;

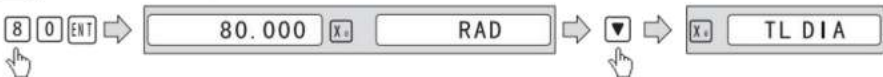

5. Input Diameter of the TOOL

Press **▲** or **▼** until “TL DIA” appears in the message window. X-window displays the formerly preset Diameter of the TOOL. Press **6** in turn to input the Diameter value;



6. Input Feed step (MAX\_CUT);

Press **▲** or **▼** until “MAX\_CUT” appears in the message window. X-window displays the formerly preset MAX\_CUT. Press **0.5** in turn to input the MAX\_CUT value;



## ARC Processing

## 7. Select outer arc or inner arc

Press or until “RAD-TL” appears in the message window. Press or to select place to display “RAD+TL” ;

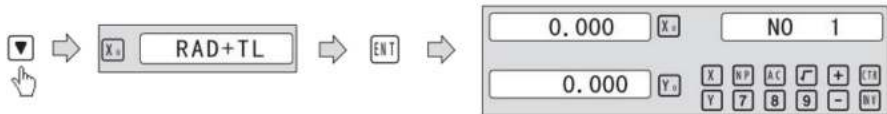

## 8. After inputting all parameters, press the key for machining.

The DRO will display the position of the first point. Retract the axes until the displays read 0.000, Machine the Arc point by point in accordance with the display. After finishing the position of the first point, press or to change position point.



Press to quit R function any time.

**Example 2 for the Simple ARC Processing:**

Parameters settings as follow:

SIMPLE	Simple mode
TYPE	3
SEL_XY	XZ .....
RAD	80.000 .....
TL_DIA	6.000 .....
MAX_CUT	0.500 .....

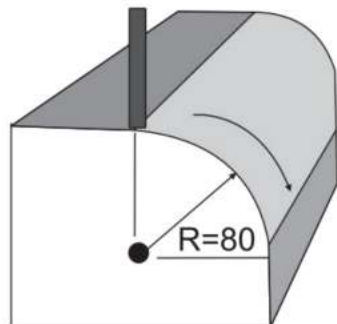

Steps:

1. Press , then the message window display “SIMPLE” to the ARC Processing. Press or to select mode of the simple, The message window display “SIMPLE”

## ARC Processing



2. Input the type:

Press **ENT** until “TYPE” appears in the message window. X-window displays the formerly preset type. Press **3** in turn



3. Select place

Press **ENT** until “SEL\_XZ” appears in the message window.

Press **▲** or **▼** to select place to display “SEL\_XZ” ;



4. Input radius:

Press **ENT** until “RAD” appears in the message window. X window displays the formerly preset the radius of ARC. Press **80** in turn to input the radius.;



5. Input Diameter of the TOOL

Press **▲** or **▼** until “TL DIA” appears in the message window. X window displays the formerly preset the Diameter of the TOOL. Press **6** in turn to input the Diameter value;



6. Input Feed step (MAX\_CUT);

Press **▲** or **▼** until “MAX\_CUT” appears in the message window. X window displays the formerly preset the MAX\_CUT. Press **0.5** in turn to input the MAX\_CUT value;



## ARC Processing

7. After inputting all parameters, press the key **ENT** for machining.

For 2-axis milling machine table, It is not installed with Z-axis, please press **▲** or **▼** to simulate position of Z-axis. Press **▲** simulate moving to the former process, and press **▼** simulate moving to the next process point.

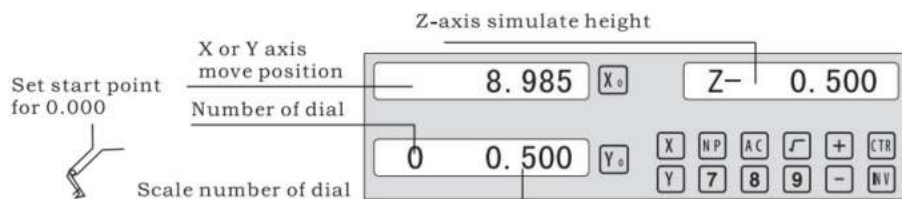

Z-axis simulate height = Number of dial x Z axis Dial + Scale number of dial

Press **▼** to quit R function any time.

### Example 3 for the Smooth ARC function:

Parameters settings as follow:

SMOOTH	Smooth mode
SEL_XY(YZ,XZ)	XY
CENTER	X=0,Y=0
RAD	80.000
TL_DIA	6.000
MAX_CUT	0.500
ST_ANG	0.000
ED_ANG	135.000
RAD+TL	1

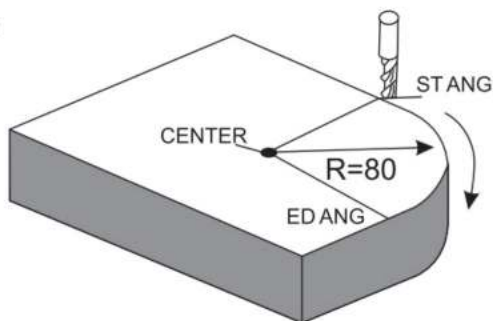

Steps:

1. Press **▼**, then the message window display "SIMPLE" to the ARC Processing. Press **▲** or **▼** to select mode of the simple, The

## ARC Processing

message window display “SMOOTH” ; For 3-axis milling machine table without this step. In second step. Then press **ENT** .



### 2. Select place

Message window display “SEL\_XY” which indicates the select is to place. Press **▲** or **▼** to select place to display “SEL\_XY” ;

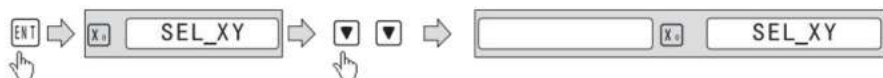

### 3. Input center position.

Press **ENT** , then the message window display “CENTER” . X and Y window displays the formerly preset center position. Input X = 0, Y = 0 as follow.

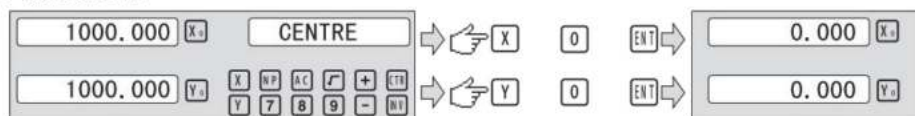

### 4. Input radius:

Press **ENT** until “RAD” appears in the message window. X window displays the formerly preset the radius of ARC. Press **8** **0** in turn to input the radius.;



### 5. Input Diameter of the TOOL

Press **▲** or **▼** until “TL DIA” appears in the message window. X window displays the formerly preset the Diameter of the TOOL. Press **6** in turn to input the Diameter value;



6. Paso de alimentación de entrada (MAX\_CUT);

prensa  o  Hasta que la aplicación "MAX CUT" aparezca en el mensaje

ventana. X Window de spa lys el anteriormente preestablecido MAX\_CUT. presione

   a su vez para ingresar el Valor de CORTE MÁXIMO;

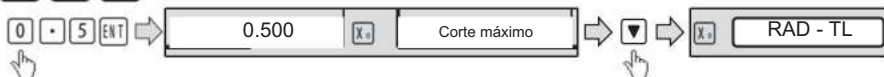

7. Ingrese el ángulo inicial.

prensa  hasta que aparezca "USTANG" en la ventana del mensaje. X

ventana de spa lys el anteriormente preestablecido el ángulo de inicio. Luego presione

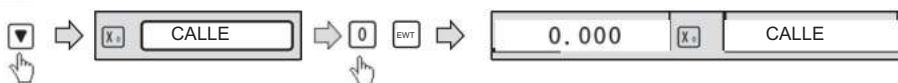

 a su vez para introducir el ángulo inicial-



8. Ángulo final de entrada.



prensa  hasta que aparezca "UED ANG" en la ventana del mensaje. X

ventana de spa lys el ángulo final preestablecido anteriormente. Luego presione

  a su vez para ingresar el ángulo final.



9. seleccione arco exterior o arco interior

Presione  o  hasta que aparezca "RAD-TL" en el mensaje

la ventana. Presione  o  para seleccionar el lugar donde se mostrará "RAD+TL";

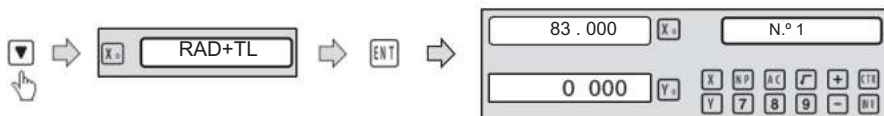

10. Después de ingresar todos los parámetros, **machining.**

El DRO mostrará la posición del primer punto. Retraiga el

ejes hasta que la pantalla muestre 0.000, mecanice el arco punto por punto en acuerdo con la pantalla. Después de terminar la posición del primer

punto, presionar  o  para cambiar el punto de posición.

## ARC Processing

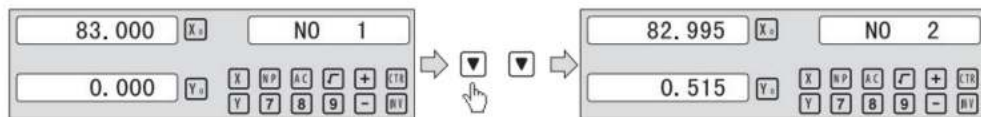

Press  to quit ARC function any time.

## 6. 4 procesamiento oblicuo

Hay 2 formas disponibles para realizar el mecanizado en posición oblicua:

A). en el lugar. b). en el lugar yz, o Xz;

Sólo es necesario introducir los siguientes parámetros:

INCLUYE <u>Xy(xz,yz)</u>	Establecer la posición de la máquina xy,yz,0rxz ·
EL	El ángulo de inclinación del oblicuo·
ALLÁ	Diámetro de la HERRAMIENTA ·
ST <u>OLLA</u>	Posición inicial;
ED <u>PUEDE</u>	Finalización de la publicación;

Ejemplo 1 para el eje xy oblicuo:

cuando el plano de mecanizado está en el plano xy como la pieza que se muestra en Figura, el ángulo de oblicuidad de la pieza de trabajo debe calibrarse.

antes de mecanizar el plano oblicuo. Por lo tanto , En este punto el

El mecanizado del plano oblicuo desempeña la función de calibrar la oblicuidad.

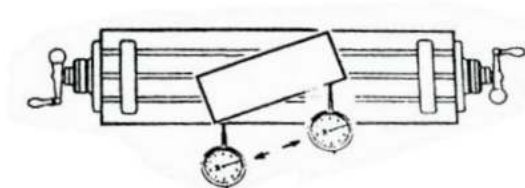

procedimiento para calibrar la oblicuidad

Primero coloque la pieza de trabajo sobre la mesa de trabajo según el ángulo requerido. de oblicuidad ·

1) Ingrese la función del plano oblicuo. 2) Seleccione

la función del plano XY.

3) Ingrese el ángulo de oblicuidad.

4) Mueva la mesa de trabajo hasta que la herramienta de medición (como un comparador de cuadrante) instalado en la fresadora toca el plano de calibración de oblicuidad, ajústelo a cero y mueva la mesa de trabajo cualquier distancia en el dirección del eje x. \_



5) Mueva la mesa de trabajo en la distancia del eje y hasta que aparezca en la pantalla se convierte en cero.

## Oblique Processing

6) Change the angle of the work piece to make the workpiece touch the measuring tool and adjust it to zero.

STEPS:



1. Select place

Press , then the message window display "INCL\_XY" to the Oblique Processing. Press  or  to select place to display "SEL\_XY";

Then press  to in next step;



2. Input the angle of obliquity

The message window display "ANG" , X window displays the formerly preset the angle of obliquity. Press   in turn to input the angle of obliquity .



3. Move the workpiece along the X-Axis until the measuring tool touches the workpiece adjust it to zero, and move the worktable for any distance along the X-Axis.



4. Press , display the value of Y-Axis. Move the workpiece along the Y-Axis, change the angle of workpiece to make the obliquity-calibrating plane touch the measuring tool until it turns to zero. Move the worktable until Y-Axis is displayed as zero.

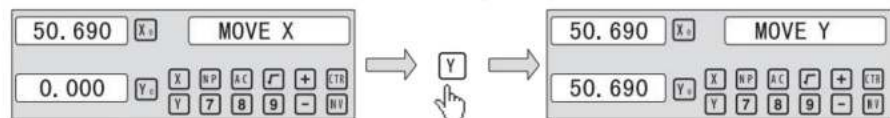

5. Press  to quit oblique function any time.

## Oblique Processing

### Example 2 for the oblique XZ or YZ place:

When the machining plane is on plane XZ or YZ, the function of TOOL inclination can instruct the operator to machine the oblique plane step by step.



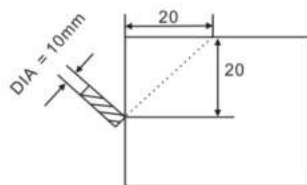
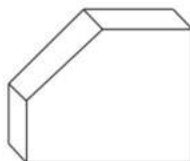

Procedures for using the function of cutter inclination:

When the machining plane is on plane XZ or YZ, first please calibrate the obliquity of the primary spindle nose and set the TOOL:

INCL_XY(XZ,YZ)	INCL_XZ
DIA	10.000
ST_POT	20.000
ED_POT	20.000





#### STEPS:

1. Press , then the message window display “INCL\_XY” to the oblique Processing. Press  or  to select place to display “SEL\_XZ; Then press  to in next step;



2. Input The TOOL Diameter

The message window display “DIA” , X window displays the formerly preset the angle of obliquity. Press   in turn to input the TOOL Diameter of obliquity . OK, then press  to in next step;



3. Input ST\_POT;

The message window display “ST\_POT” , X and Y window displays the formerly preset the stating position of obliquity. Input X= 0, Y = -20.000. OK, then press  to in next step;

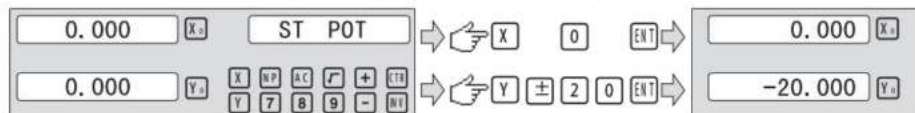



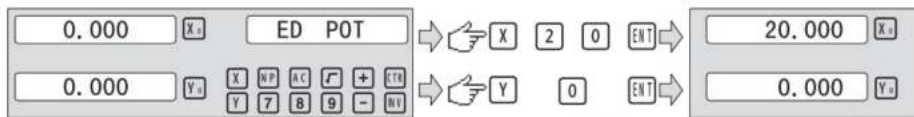

## Oblique Processing

### 4. Input ED\_POT;

The message window display “ED\_POT” , X and Y window displays the formerly preset the starting position of obliquity. Input X= 20.000, Y = 0.000 .



### 5. After input all parameter, press the key for machining.

For 2-axis milling machine table , It is not installed with Z-axis, please press  or  to simulate position of Z-axis. Press  simulate moving to the former process, and press  simulate moving to the next process point.

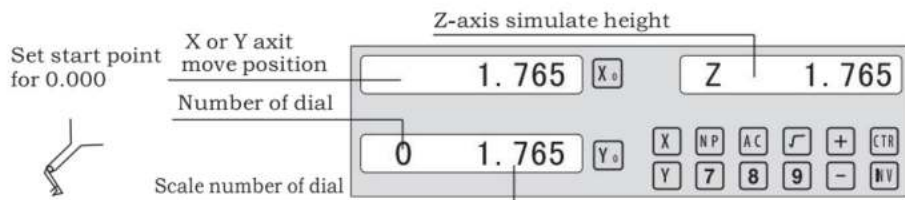

Z-axis simulate height = Number of dial x Z axis Dial + Scale number of dial

Press  to quit **oblique** function any time.

## Slope Processing



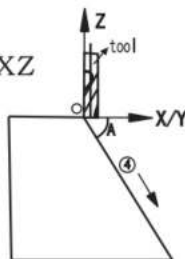

## 6.5 Slope Processing

This function can calculate the position of every processing point automatically in processing slope. Only the following parameters need to be inputted:

XZ, YZ	Set machine place YZ, or XZ
ANG	The inclination angle
Z_STEP	The slope length each time processing



**Example 1 for the Slope XZ place;**

Step 1. Select place

Press , then the message window display “XZ” to the slope Processing. Press  or  to select place to display “SEL\_XY; Then press  to in next step;





Step 2. Input the angle of slope

The message window display “ANG”, X window displays the formerly preset the angle of slope. Press   in turn.



Step 3. Input Z\_step;

The message window display “Z STEP”, X window displays the formerly preset the stating position of slope. Input    in turn.

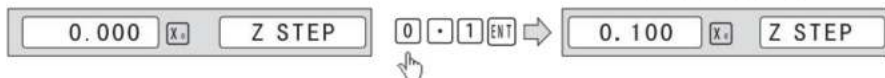

Step 4: Finishing the ALL processing . Press  to quit slope function any time.

## Chambering Processing

### 6.6 Chambering Processing

1, FLAT\_XY: machine place; 2, DIA: diameter of TOOL; 3, CENTER: center of the chambering ; 4, SIZE: size of the chambering ;

Figure as follow:

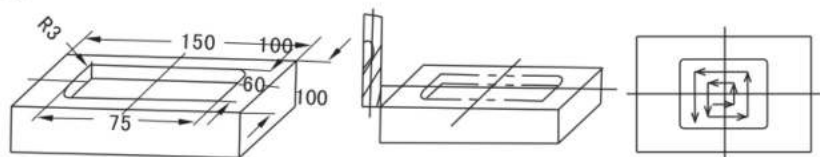

STEPS:

1. Press , then the message window display "FLAT\_XY" to the Chambering Processing.



2. Input DIA of the TOOL;





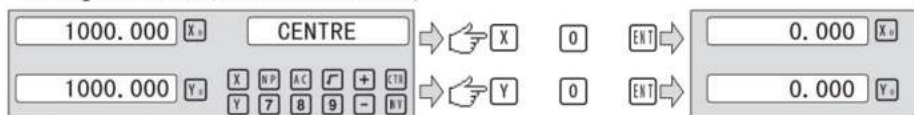

3. Input the center coordinate;

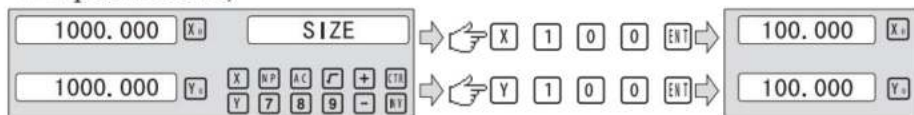

4. Input the size;



5. process Chambering;

Move the machine until the display of the axis is zero, ie, the position of the first point. Machine the first point . Display the next machining point by pressing  or  .On the completion of machining, the right window shows OVER. Press  or , the system will goto the first position for the next workpiece. Press  to quit the Chambering Function.

## The Tool Diameter Compensation Function

### 6.7 The Tool Diameter Compensation Function

Without TOOL compensation, the operator has to move the TOOL for an additional distance of the diameter of the TOOL along each side when machining the four 150 and 100 sides of a workpiece to finish machining the whole brim. The digital readouts shall automatically compensate when the TOOL compensation function is enable.

Note: the TOOL compensation is made in the direction of X and Yaxis.

Procedures:

- 1). Enter the function of compensating the diameter of the TOOL.
- 2). Select one of the (four) preset machining modes.
- 3). Input the diameter of the TOOL.
- 4). Enter machining.

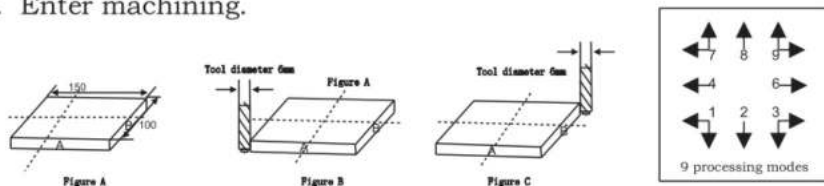

Step1: press  $\frac{Dm}{13}$  to enter the TOOL compensation Function. then the message window display “TYPE” .Press **9** .



Step 2: input the diameter of the TOOL; Press **1** **0** in turn..



Step 3: Press  $\nabla$  to the machining Mode.

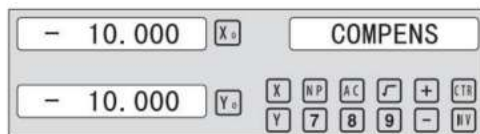

Machining of 2 side planes can be done by moving the TOOL until X-Axis is 150.000 and Y-Axis is 100.000.Press the Key  $\frac{Dm}{13}$  to quit the Function.

## The Tool Diameter Compensation Function

---

### 6.8 Digital Filter of the Grinding Machine

When machine a work-piece by grinder, the display values quickly due to the vibration of grinder. User can not see display value clearly. Grinder DRO provides display value filter function to disable the quake change of display value.

STEPS:

1. Enter display value filter function.

In normal display state, press **SFT** to simultaneously, enter display value filter function.

2. Exit display value filter function;

Press **SFT** , exit display value filter function;

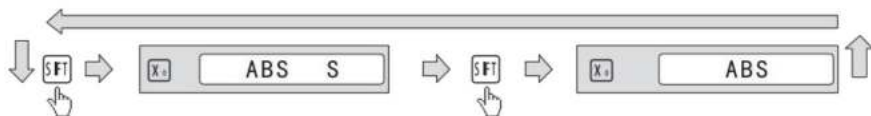

## 6. 9 La Función

6.9.1 200 conjuntos de bibliotecas de herramientas

Siempre se necesitan diferentes herramientas al procesar diferentes piezas. Para Operación conveniente, el La las lecturas digitales tienen la función de

200 conjuntos de bibliotecas de herramientas.

Nota: solo cuando la la está equipada con el bloque de configuración de herramientas se pueden utilizar los 200 conjuntos de bibliotecas de herramientas.

1. Establezca una HERRAMIENTA de referencia. Después de configurar la herramienta, ponga a cero el eje X y el eje Z, establecer cero de la coordenada absoluta

2. De acuerdo con el tamaño de TOOL I y datum TOOL, determine la

Posición de la HERRAMIENTA con respecto al cero de la herramienta de coordenadas absolutas y de referencia. AS Figura 6-1. El tamaño relativo de la HERRAMIENTA 2 es AS según el eje x 25-30= 5, Eje Z 20-10=10.

3. guarde el número de HERRAMIENTA y el tamaño en la lectura digital.

4. El número de HERRAMIENTA se puede ingresar de forma aleatoria, las lecturas digitales mostrará la posición de la herramienta en la coordenada absoluta cero. Mover la hasta que el eje X y el eje Z muestren cero. 5. TOOL Libs puede guardar los 200 conjuntos de datos de herramientas.

6. Las bibliotecas TOOL deben usarse en el estado de apertura. Los 200 conjuntos

Las bibliotecas rooi se pueden abrir presionando continuamente  diez veces

hasta que la ventana derecha parpadee TL - OPEN y aparezca una marca "21" en La izquierda de la ventana de información derecha. La marca indica la

El operador puede configurar o revisar los 200 conjuntos de herramientas de biblioteca de forma continua.

Al presionar la tecla se  Diez veces provocará que las bibliotecas de herramientas 200sets sean cierra y la ventana derecha parpadea TL - CLOSE y la marca

desaparecer. cuando la marca "21" desaparece los 200 conjuntos TOOL Libs pueden no ser revisado

Las operaciones para los datos de TOOL y la llamada de TOOL se muestran a continuación.

paso 1: En el estado ABS, ingrese los datos de los 200 conjuntos de bibliotecas de TOOL.

abriendo los 200 conjuntos TOOL Libs presionando continuamente la tecla

 diez veces A. La marca "" aparecerá en la ventana izquierda de la derecha ventana de información.

## Lathe Function

Paso 2: presione **TOOL** para ACCEDER al estado de entrada. Datos de entrada de rooi 1:

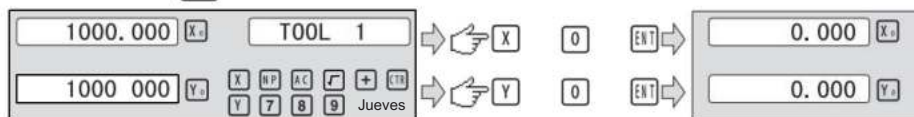

Paso 3: Ingrese los datos de la HERRAMIENTA 2:

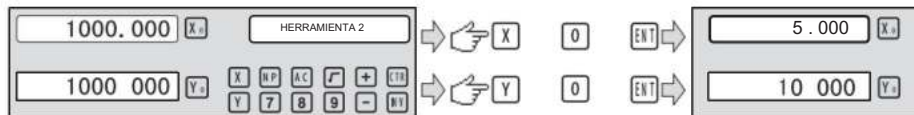

Paso 4: presione para continuar ingresando los datos de la siguiente herramienta.

número y la tecla el operador puede ingresar directamente el especial

Datos de herramientas. prensa **TOOL** toca

Después de configurar las bibliotecas TOOL, use las bibliotecas TOOL de acuerdo con las Las siguientes operaciones primero montan la segunda herramienta .

Paso 5: Para acceder al estado de uso mediante pr css **CALL** .Entonces pr css **2** EN Yo .



Paso G: presione **▲** o **▼** . Seleccione la rueda base. Luego presione **1** YT .



Paso 7: presione **CALL** para salir de la función;

Nota:

cuando se utiliza la herramienta base , El eje no se puede poner a cero en estado ABS  
 Cuando se utilizan los demás , El eje solo se puede poner a cero en el estado INC

### 6 . 9 . 2 Función de conicidad

Para torneear la pieza de trabajo con cono, la conicidad de la pieza de trabajo puede medirse en el procesamiento;

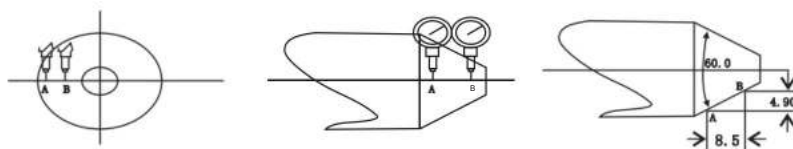

## Lathe Function

### Operations :

Figura AS, superficie de contacto A de la pieza de trabajo con lecturas de palanca y restablece el punto de lectura de la palanca a cero ·

Paso 1: presione y luego la ventana de mensajes mostrará "UMEASU"

Procesamiento de papel · Mueva la palanca de lectura a la superficie B hasta que

Las lecturas de palanca apuntan a lo siguiente:

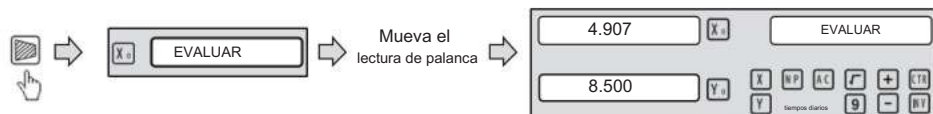

Paso 2: presione T para calcular.

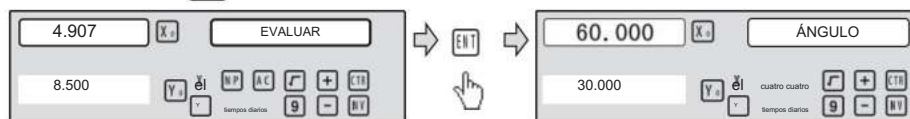

Paso 3: presione para salir de la función;

### 6 . 9 . 3 Función R/D

Para torno de 2 ejes y torno de 3 ejes, prensa



, El modo de visualización

El eje x cambia entre Radio y Diámetro. cuando el eje x para

visualización de Diámetro, una marca u " " aparecerá a la izquierda de la derecha

ventana de información, pero cuando el eje X para la visualización de ia metro , La marca

" " desaparece · solo el eje x tiene la función de diámetro/radio transformation.

### 6. 9. 4 Función Y + Z (solo aplicable a: 3 ejes La)

Para 3 ejes La, el contador del eje y y el contador del eje z

Se puede agregar a la visualización en el eje Z presionando la tecla



luego presione la tecla CAn cancelar la función y + Z ·

6.10 EDM (función de personalización especial, si necesita comprar, por favor  
 Contacte con el distribuidor para personalizarlo)

1 Descripción: Esta función se utiliza para el mecanizado especial de

Mecanizado por electroerosión (EDM). cuando se alcanza el valor objetivo establecido de EDM  
 El eje Z es igual al valor actual, la lectura digital emitirá el  
 Cambiar la señal para controlar la EDM para detener el mecanizado de profundidad.

La configuración de la dirección del eje Z de la lectura digital se muestra en la figura 1. ,  
 es decir Cuanto mayor sea la profundidad, mayor será el valor de la coordenada del eje Z.  
 muestra · desde que se inicia el mecanizado, la profundidad se irá haciendo cada vez más profunda  
 y el eje Z.

Según la dirección del eje Z establecida, la dirección de mecanizado es  
 dividido en mecanizado positivo y negativo · cuando el electrodo  
 desciende y el mecanizado se realiza de arriba hacia abajo, el digital  
 El valor de lectura aumentará, lo que se denomina mecanizado positivo (positivo).  
 La configuración de esta dirección es la configuración normal.

cuando el electrodo ASC Ends y se realiza el mecanizado  
 De abajo hacia arriba, el valor de lectura digital disminuirá · El  
 La dirección de mecanizado es la dirección negativa (negativa), que también se denomina  
 mecanizado negativo (mostrado en la Fig. 1)

El lector digital también cuenta con otras funciones , tal como negativo  
 Altura de resistencia al fuego. La función de altura de resistencia al fuego negativa es un tipo de  
 Dispositivo de protección de seguridad de control de seguimiento de posición inteligente. En el proceso  
 Durante el mecanizado, la superficie del electrodo generará el carbono.  
 Fenómeno de acumulación. Debido al mecanizado prolongado o diurno.  
 Sin cuidar, al generar la acumulación de carbono y  
 Nadie hace la limpieza, el electrodo irá aumentando lentamente a lo largo de la  
 dirección negativa · una vez que el electrodo excede el nivel del líquido,  
 se incendian con frecuencia y causan pérdidas. Esta función está configurada solo para apuntar  
 En este problema, al establecer una altura ignífuga negativa, y el  
 La altura aumentada del electrodo excede la altura entre éste y el  
 profundidad de la superficie mecanizada (es decir, altura ignífuga negativa), la digital  
 La pantalla de lectura parpadeará para WQring; al mismo tiempo, la salida  
 La señal apagará automáticamente el EDM para eliminar la posibilidad de incendio.



Figura 1



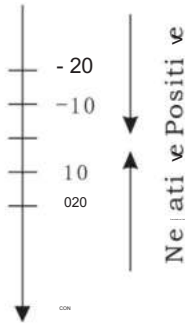

Figura 2

## 2. procedimiento:

Vea el siguiente ejemplo para un mecanizado detallado.

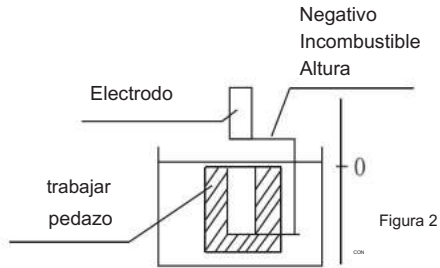
- 1) Antes de mecanizar, configure primero cada parámetro de PROFUNDIDAD (profundidad de mecanizado); ERRHIGH (altura ignífuga negativa), mecanizado dirección (POSITIVO / NEGATIVO); modo de salida (AUTO/STOP) y Modo de salida de relé EDM · 2)

Mueva el electrodo del eje principal del eje Z para que entre en contacto con el Referencia de la pieza de trabajo · Poner a cero el eje A o establecer el valor ·

- 3) Ingrese al mecanizado EDM presionando la tecla CSS .

4) El eje X mostrará el valor objetivo de profundidad de mecanizado. El eje Y mostrará El valor de visualización debe ser la profundidad. (El valor en el eje Y es el valor en el que la pieza de trabajo ha sido mecanizada en profundidad) El eje Z Muestra el valor de autopoición en tiempo real. (El valor en el eje Z es el Valor de posición del electrodo del eje principal del eje z.)

5) Comience a mecanizar, el valor de visualización del eje Z se acerca gradualmente al valor objetivo, el valor de visualización del eje y también se acerca gradualmente al valor objetivo. Si en este momento, el electrodo se mueve repetidamente hacia arriba y hacia abajo, el valor de visualización del eje Z cambiará posteriormente, pero el valor de visualización del eje Y El valor no cambiará, lo que siempre mostrará la profundidad mecanizada.

### value.

- 6) cuando el valor de visualización del eje Z es igual al valor objetivo establecido,

El interruptor de alcance de posición se apagará, la EDM detendrá el mecanizado.

Según la configuración del operador · Hay dos tipos de modos de salida:

## a) Automatic Mode:

it will automatically exit from EDM machining status and recover to the original state before machining;

## b) Stop Mode:

It will always stay at the machining interface after finishing machining, and you should press **EDM** to exit and back to the original state.

**Operation steps:**

**The DEPTH (machining Depth), ERRHIGH (Negative fireproof height), exit Mode, EDM Relay Output Mode and machining direction should be set.**

**STEPS:**

1. Press **EDM** to enter the EDM Function. Press **▲** to input parameters; Press **▼** to enter EDM machining state.

2. Input DEPTH ( machining depth). Press the key **▲** to set the next parameter.



3. input ERRHIGH ( Negative Fireproof Height ) (undefine) .Press the key **▲** to set the next parameter.



4. Set machining direction(Positive or Negative). Press **1** to select Positive direction. Press **0** to select Negative direction. Press the key **▲** to set the next parameter.



## EDM

5. Set exit Mode (AUTO Mode or STOP Mode) Press **0** to select AUTO Mode; Press **1** to select STOP Mode ; Press the key **▲** to set the next parameter.

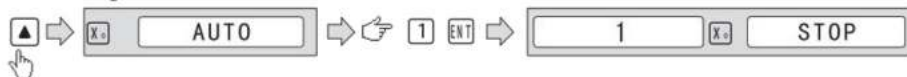

6. Set the Output Mode (Mode 0 or Mode 1); ( undefine ). Press **0** to select Mode 0; Press **1** to select Mode 1.

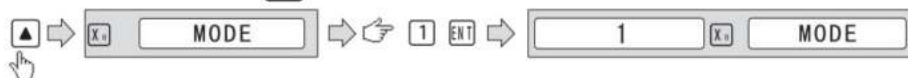

7. Continuously press **▼** to return EDM for machining. press **EDM** to quit the function;

### Example 1: positive direction machining ;

Machining is shown as the model chamber as follows

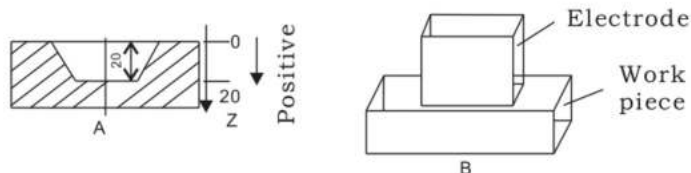

#### STEPS:

1、Touch one side of the workpiece with the TOOL, then press **Z0** , zero the Z axis.



2、 Press **EDM** , Setting DEPTH for 20.000; press **▼** to EDM for machining;



3、 Starting machining.

## EDM

Machining depth target value	<input type="text" value="20.000"/>	<input type="button" value="X0"/>	<input type="button" value="EDM RUN"/>
Value has been to be depth	<input type="text" value="0.000"/>	<input type="button" value="Y0"/>	
Self-position real time value	<input type="text" value="0.000"/>	<input type="button" value="Z0"/>	

**Example 2: Negative direction machining**

Machining is shown as the model chamber as follows

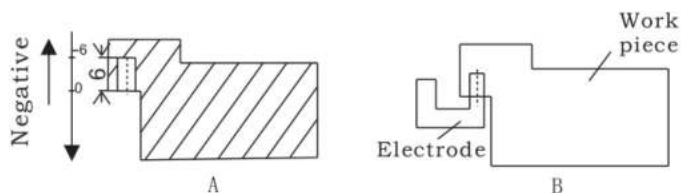

- 1、Touch one side of the workpiece with the TOOL, then press  , zero the Z axis.

<input type="text" value="1000.000"/>	<input type="button" value="Z0"/>	→	<input type="button" value="Z0"/>	→	<input type="text" value="0.000"/>	<input type="button" value="Z0"/>
---------------------------------------	-----------------------------------	---	-----------------------------------	---	------------------------------------	-----------------------------------

- 2、Press  , Setting DEPTH for -20.000; press  to EDM for machining;

<input type="button" value="EDM"/>	→	<input type="button" value="X0"/>	<input type="text" value="DEPTH"/>	→	<input type="button" value="±"/>	<input type="text" value="20"/>	<input type="button" value="0"/>	<input type="button" value="ENT"/>	→	<input type="text" value="-20.000"/>	<input type="button" value="X0"/>	<input type="text" value="DEPTH"/>
------------------------------------	---	-----------------------------------	------------------------------------	---	----------------------------------	---------------------------------	----------------------------------	------------------------------------	---	--------------------------------------	-----------------------------------	------------------------------------

- 3、Starting machining.

Machining depth target value	<input type="text" value="20.000"/>	<input type="button" value="X0"/>	<input type="button" value="EDM RUN"/>
Value has been to be depth	<input type="text" value="0.000"/>	<input type="button" value="Y0"/>	
Self-position real time value	<input type="text" value="0.000"/>	<input type="button" value="Z0"/>	

**Example 3: PCD Function for EDM**

PCD Function can access the EDM Function . The operator enters PCD Function to input parameters for PCD and enter PCD machining state. At every position for machining, press the key  to access the EDM Function .



Al ingresar a la función EDM, el operador puede ingresar los parámetros para EDM ·

El procedimiento de operación es el siguiente:

1) Establezca los parámetros PCD (la configuración es la misma que la configuración común) de PCD)

Después de ingresar todos los parámetros e ingresar al estado de mecanizado PCD · El Se mostrará la posición del primer hoyo.

2) presione  para ingresar el parámetro de función EDM (el método de configuración es lo mismo que la configuración común del parámetro EDM); después de ingresar todo

parámetros, presione continuamente cuando  para ingresar al estado de mecanizado finalice el mecanizado, presione para ingresar al  EDM. para salir de la función EDM y estado de mecanizado PCD ·

3 )En el estado de mecanizado PCD, presione  Para la posición del siguiente agujero, OVE la máquina al valor de visualización 0 , luego pr css  Para acceder Función EDM nuevamente ·

4) Repita el paso 2 y el paso 3 para los siguientes puntos de mecanizado.

## Calculator

### 7 calculadora

La calculadora no solo proporciona cálculos matemáticos normales como por ejemplo +, -,  $\times$ , /, también proporciona cálculos trigonométricos en métricos como AS PEGADO, Arc SIN, PORQUE, Arco COS, BRONCEARSE, Arco TAN SQRT etc.

Las operaciones son las mismas que las calculadoras comerciales, fáciles de usar.  
Entrar y salir de la función de calculadora

En estado de visualización normal: presione  para ingresar a la función de calculadora.

En el estado de visualización de la calculadora: presione  para salir de la función de calculadora.

Calculadora de transferencia El resultado es el zx seleccionado.

Una vez finalizado el cálculo, si el modo de visualización de la calculadora está configurado para Modo 1, El usuario puede:

Al  para trasladar el resultado calculado al eje x; luego, x presionar la ventana se mostrará este valor;

presiona  para transferir el resultado calculado al eje del juguete; luego La ventana mostrará este valor;

Al  para transferir el resultado calculado al eje z; luego el eje z presionar la ventana se mostrará este valor;

Transfiriendo el valor actual de Displayvalueinwindow a la calculadora.

Si la calculadora muestra el modo establecido en el modo 1, El usuario puede:

presiona  para transferir el valor mostrado en la ventana x a la calculadora;

presiona  para transferir el valor de visualización en la ventana Y para calcular r;

presiona  para transferir el valor mostrado en la ventana z a la calculadora;

## Appendix

## 8 Appendix

## 1. Troubleshooting:

The following are the preliminary solvents for troubleshooting.

If there is still trouble, Please contact out company or agents for help.

Troubles	Possible reasons	Solvents
No display	<ol style="list-style-type: none"> <li>1. Power isn't connected</li> <li>2. Power switch is off.</li> <li>3. The range of power voltage is not right.</li> <li>4. The inner power of Linear Scale is short.</li> </ol>	<ol style="list-style-type: none"> <li>1. Check power wire and connect the power</li> <li>2. Turn on the power switch.</li> <li>3. The range of voltage is in 80--260V</li> <li>4. Unplug the connector of linear scale</li> </ol>
One axis is not counting	<ol style="list-style-type: none"> <li>1. Replace the linear scale of the other axis.</li> <li>2. DRO is in special function</li> </ol>	<ol style="list-style-type: none"> <li>1. If count is normal, the linear scale has trouble; If abnormal, the DRO readouts has trouble.</li> <li>2. Quit the special function.</li> </ol>
Linear scale is not counting	<ol style="list-style-type: none"> <li>1. Reading head is bad for using range exceeds.</li> <li>2. Aluminum chips is in reading head of linear scale.</li> <li>3. The span between the reading head and metal part of linear scale is large.</li> <li>4. The metal parts of linear scale is damage.</li> </ol>	<ol style="list-style-type: none"> <li>1. Repair the linear scale</li> <li>2. Repair the linear scale</li> <li>3. Repair the linear scale</li> <li>4. Repair the linear scale</li> </ol>
Counting is error	<ol style="list-style-type: none"> <li>1. Shell is poor grounding.</li> <li>2. Low precision of machine.</li> <li>3. Speed of machine is too rapid.</li> <li>4. Precision of linear scale is low.</li> <li>5. The resolution of DRO readouts and the linear scale is not match.</li> <li>6. The unit (mm/inch) is not match.</li> <li>7. Setting the linear compensating is not arrest.</li> <li>8. Reading head of the linear scale is damaged.</li> </ol>	<ol style="list-style-type: none"> <li>1. Shell is good grounding.</li> <li>2. Repair the machine.</li> <li>3. Reduce the speed of machine.</li> <li>4. Mount the linear scale again.</li> <li>5. Set the resolution of the DRO again.</li> <li>6. Cover the unit of display mm/inch.</li> <li>7. Reset the linear compensation.</li> <li>8. Repair the linear scale.</li> </ol>
The counting of the linear scale is not accurate	<ol style="list-style-type: none"> <li>1. The mounting of linear scale does not demand the requirement, and the prcision is not adequate.</li> <li>2. The screw is loosen.</li> <li>3. Precision of machine is low.</li> <li>4. The resolution of digital readouts and the linear scale is not match.</li> </ol>	<ol style="list-style-type: none"> <li>1. Mount the linear scale again and level it.</li> <li>2. Lock all fixing screws.</li> <li>3. Repair the machine.</li> <li>4. Reset the resolution of digital readouts.</li> </ol>
Sometimes the linear scale is not counting	<ol style="list-style-type: none"> <li>1. The small car and steel ball is separated.</li> <li>2. The glass of reading head is wearied.</li> <li>3. The glass of reading head of the linear scale has dirt.</li> <li>4. The elasticity of the steel wire is not adequate.</li> </ol>	<ol style="list-style-type: none"> <li>1. Repair the linear scale.</li> <li>2. Repair the linear scale.</li> <li>3. Repair the linear scale.</li> <li>4. Repair the linear scale.</li> </ol>

## Appendix

### 2. Specifications of Digital Readout.

- 1) Supply Voltage range: AC 85 V ~ 230 V; 50 ~ 60 Hz
- 2) Power consumption: 15VA
- 3) Operating temperature: 0°C-- 50°C
- 4) Storage temperature: - 30°C-- 70°C
- 5) Relative humidity: < 90 % ( 25 )
- 6) Max Coordinate number: 3
- 7) Readout allowable input signal: TTL square wave
- 8) Allowable input signal frequency: < 5 M Hz
- 9) Max resolution of digital display length: 0.01  $\mu$ m
- 10) Max resolution of digital display angle: 0.0001 / PULSE

### 3. Instructions

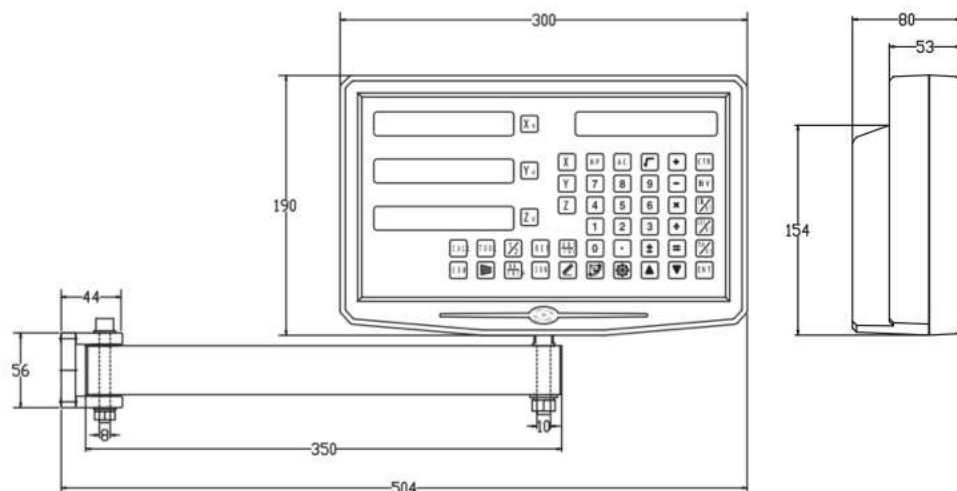

## 4. Examples of character output at the data interface

## 1、 X,Y,Z Axis

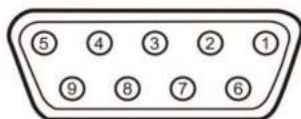

Pin	TTL (Standard)
1	
2	OV
3	
4	
5	
6	A+
7	5V
8	B+
9	R+

Pin	TTL (Standard)
1	5V
2	OV
3	A+
4	B+
5	R+
6	
7	
8	
9	

For your convenience,  
If you buy a digital readout,

The wiring definition of your linear scale must be the same as the 2 definitions in the above diagram to be universal!

# Installation Instructions

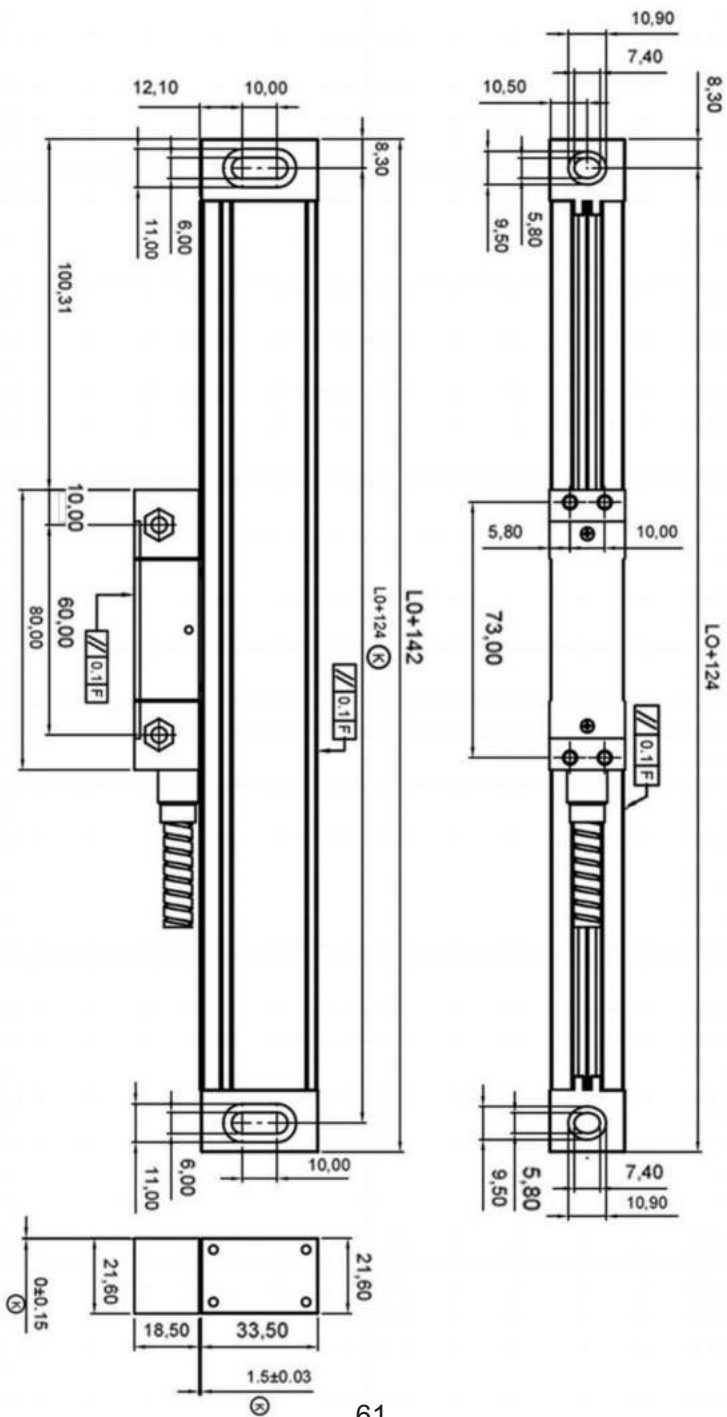

## TTL signal Output:

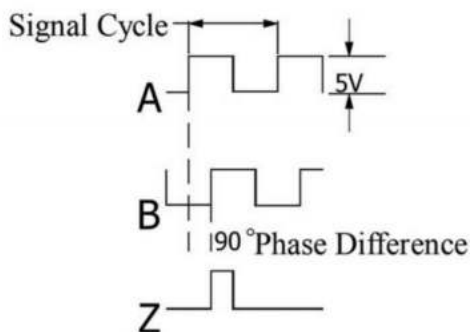

## EIA-422-A signal Output:

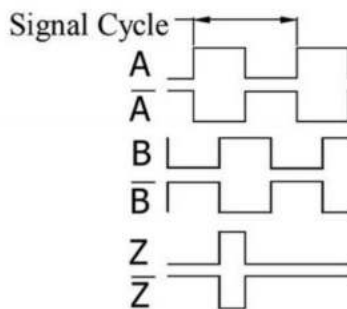

## 1. TECHNICAL PARAMETER

1.1 SCALING DISTANCE: 0.02 MM (50LINES /MM)

1.2 RESOLUTION: 5 $\mu$ M、1 $\mu$ M、0.5 $\mu$ M1.3 PRECISION:  $\pm 3\mu$ M、 $\pm 5\mu$ M、 $\pm 15\mu$ M/M (20 $\pm$ 0.1°C)

1.4 MEASURING RANGE: 30~3000MM

1.5 MOVING SPEED: HIGH-SPEED ENCODER 120 M/MIN (TO BE CUSTOMIZED)

ORDINARY ENCODER 60M/MIN

1.6 POWER SUPPLY: +5V $\pm$ 5%、80MA

1.7 CABLE LENGTH: STANDARD 3M (SPECIAL LENGTH AVAILABLE ACCORDING TO THE USER'S NEEDS)☒

1.8 WORKING TEMPERATURE: 0~45°C

1.9 PIN DESCRIPTION:

1) APPLICABLE TO: 9 PIN SOCKET EIA-422-A SIGNAL OUTPUT.

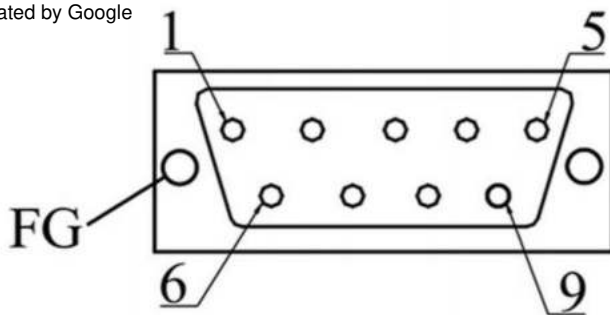

1) Applicable to: 9 pin socket EIA-422-A signal Output.

Pin Position	1	2	3	4	5	6	7	8	9
Signal	$\bar{A}$	$OV$	$\bar{B}$	Empty	$\bar{Z}$	$A$	+5V	$B$	$Z$
Color	Green Black	Black	Orange black	FG	White black	Green	Red	White	Orange

FG: Shield connected to metal casing.

1) Applicable to: 9 pin socket TTL signal Output.

Pin Position	1	2	3	4	5	6	7	8	9
Signal		$OV$		Empty		$A$	+5V	$B$	$Z$
Color		Black		FG		Green	Red	Orange	White

FG: Shield connected to metal casing.

# Escala lineal

## Dibujos de instalación

# Método de instalación:

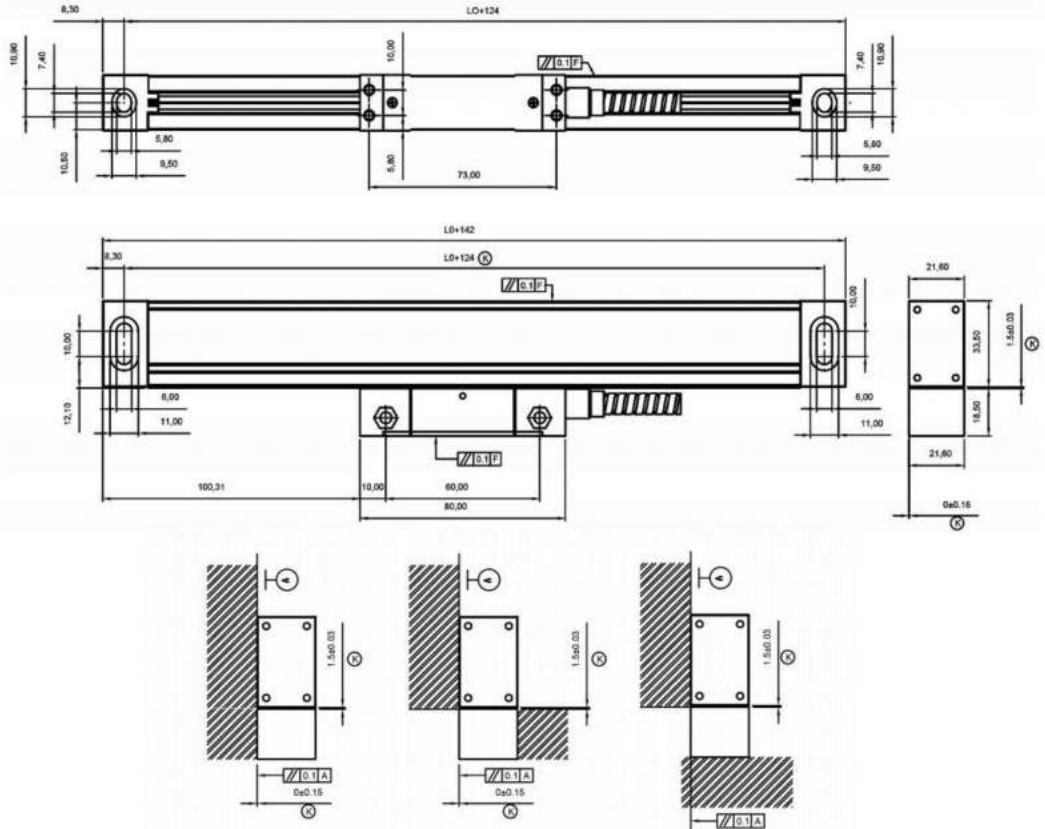

Tamaño estándar: (Unidad: mm)

Modelo	LO	L1	L2	Modelo	LO	L1	L2
YE-50	50	174	190	YE-550 550		674	690
YE-100	100	224	240	YE-600	600	724	740
YE-150	150	274	290	YE-650 650		774	790
YE-200 200		324	340	YE-700 700		824	840
YE-250 250		374	390	YE-750	750	874	890
YE-300 300		424	440	YE-800	800	924	940
YE-350 350		474	490	YE-850 850		974	990
YE-400 400		524	540	YE-900	900	1024	1040
YE-450 450		574	590	YE-950 950		1074	1090
YE-500 500		624	640	YE-1000 1000		1124	1140

L0: Longitud de medición efectiva del codificador lineal; L1: Longitud del codificador lineal  
Orificios de montaje; L2: Longitud total del codificador lineal

## Mantenimiento:

1. El recorrido efectivo del codificador lineal debe ser mayor que el máximo Recorrido de la máquina herramienta. Si la longitud no es suficiente, sustituya el codificador lineal por uno de mayor recorrido o añada un bloque de límite a la máquina. La posición final del cabezal de lectura desde el extremo del cuerpo del codificador lineal no debe ser inferior a 10 mm (consulte el siguiente diagrama).

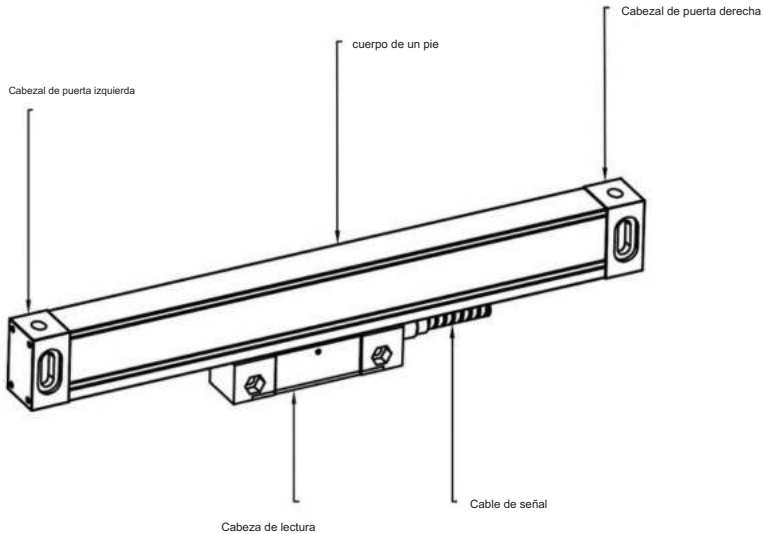

2. Para cualquier superficie no mecanizada, se debe colocar una cuña en la parte posterior del codificador lineal o se debe utilizar una cuña de instalación hecha por el usuario para garantizar la estabilidad y confiabilidad de la conexión entre la regla de rejilla y la superficie de montaje.
3. Al utilizar un comparador o un instrumento similar para calibrar el paralelismo del codificador lineal, el ángulo del cabezal lateral debe estar dentro de  $\pm 30$  grados, y cuanto menor sea el ángulo, mejor.

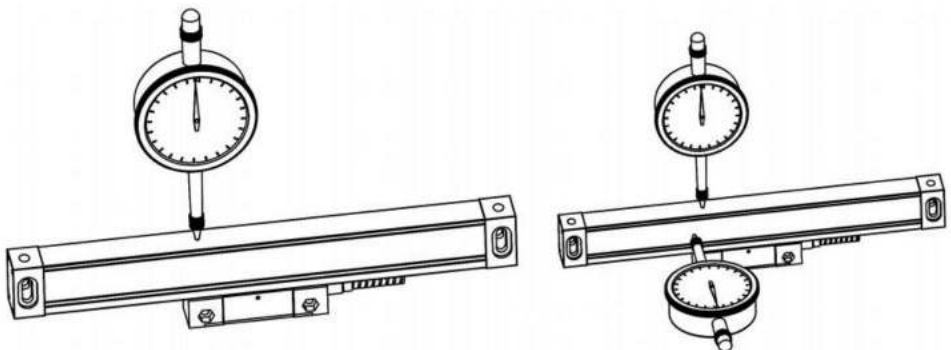

4. La posición de instalación del codificador lineal debe evitar el impacto directo del hierro.

limaduras, aceite, agua y polvo (como se muestra en la figura siguiente). La longitud de instalación

La placa en L debe ser lo más corta posible en las posibles circunstancias, y

Se debe tener en cuenta la situación de fuerza de la superficie de montaje.

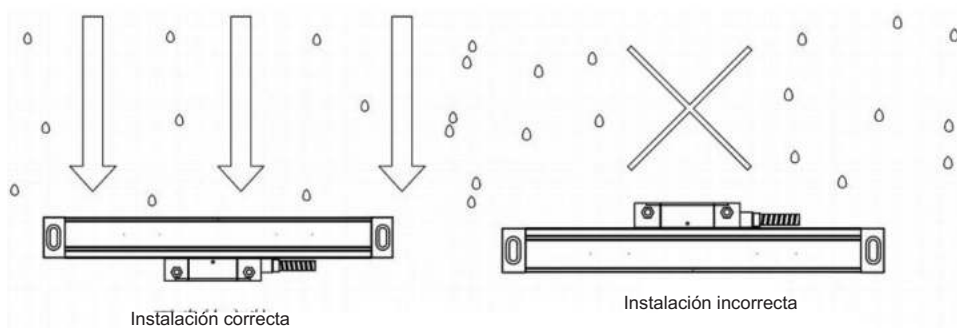

5. Debe haber un espacio de 0,5 mm o más entre la cubierta antipolvo y la regla.

cuerpo y evite el contacto entre la cubierta antipolvo y el cuerpo de la regla cuando

moviendo el cabezal de lectura (como se muestra a continuación).

6. Profundidad de la rosca del tornillo de instalación, debe tener al menos 6 dientes de profundidad de bloqueo;

La parte más importante de la fuerza, como el soporte de la placa fija del estante del medidor de pantalla digital,

debe tener 8 dientes de profundidad de bloqueo; serie YE de escala, la profundidad de la rosca

Profundidad de bloqueo. Por ejemplo, para fijar el estante del medidor de pantalla digital.

placa, debe tener más de 8 dientes de profundidad de bloqueo; escala de la serie YE Con tornillos M4

Instalación de la superficie de montaje roscada después del desbarbado de la superficie, la pintura y la eliminación de manchas.

(La siguiente figura)

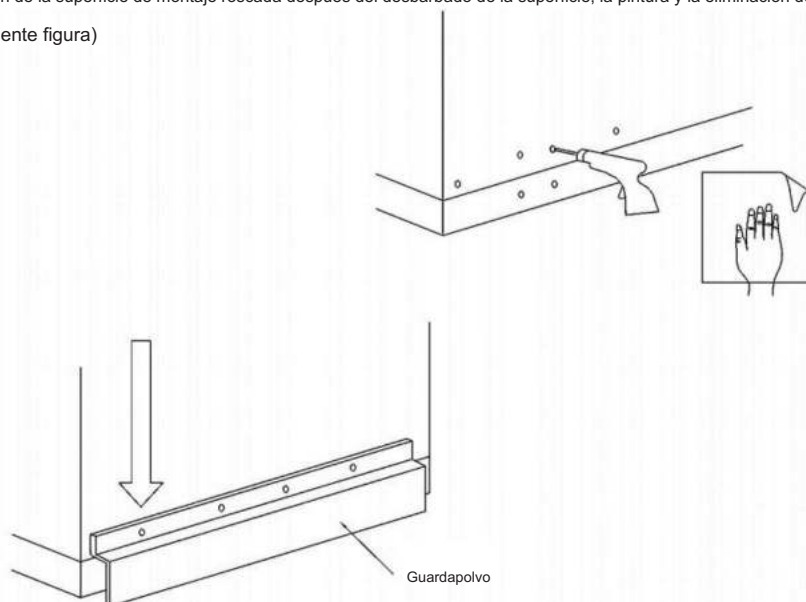

7. La fijación de la línea de señal debe tener en cuenta todas las distancias de movimiento relevantes.

La posición de fijación se coloca lo más cerca posible del centro del recorrido y el exceso de línea de señal se fija con una brida de alambre.

8. El ajuste de la altura de la escala debe ser la longitud del centro de la escala para tomar los dos lados del punto de simetría. Para ajustar el punto de referencia, cualquier escala independientemente de la dirección del nivel de la escuela o la dirección de la altura, el rango de ajuste: para el cuerpo de la escala, hasta la cabeza desde el cuerpo de la escala a una distancia de no más de 20 mm desde cada extremo prevalecerá. Para el cabezal de lectura, entre las dos superficies de referencia cuadriláteras (la siguiente figura)

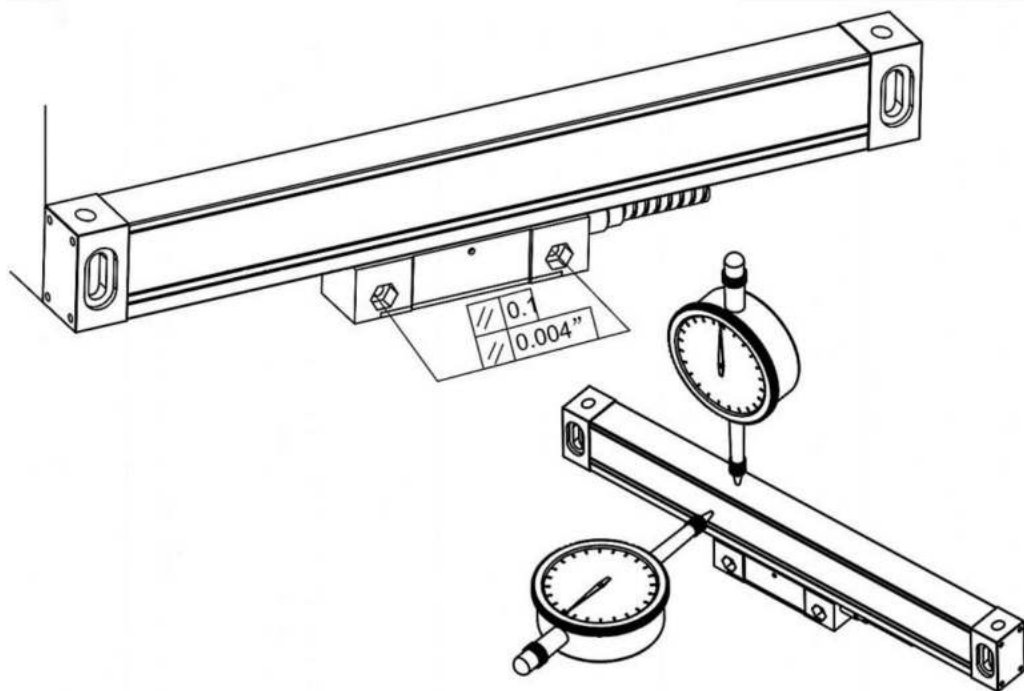

9. El radio de curvatura de la línea de señal de la escala es mayor a 60 mm.

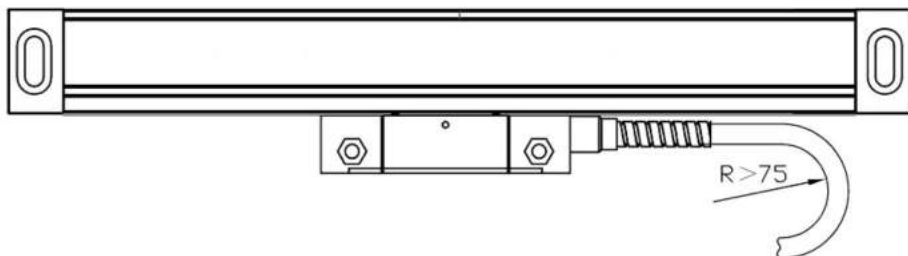

## 10. Norma de instalación de la báscula

(1) Estándar de superficie de la base de instalación (Figura 4.8abc tres métodos de instalación)

1. La superficie de instalación del cuerpo de la regla es paralela a la superficie de instalación del cabezal de lectura y el paralelismo entre las superficies de instalación es  $<0,1$  mm.

2. La superficie de instalación del cuerpo de la regla es perpendicular a la instalación.

superficie del cabezal de lectura y la perpendicularidad entre las superficies de instalación es  $<0,1$  mm

2) Normas de instalación del cuerpo de la regla (Figura 4.9, Figura 4.10)

1. Dirección de altura relativa al paralelismo de la guía de la máquina  $<0,1$  mm, máximo no más de 0,15 mm. En términos de punto de simetría, cuanto más pequeño, mejor.

3) Normas de instalación del cabezal de lectura

1. El espacio libre entre el cabezal de lectura y la dirección de altura del cuerpo de la regla es de 0,8 mm a 1,6 mm después de la instalación, y luego retire el bloque de almohadilla (Figura 4.11)

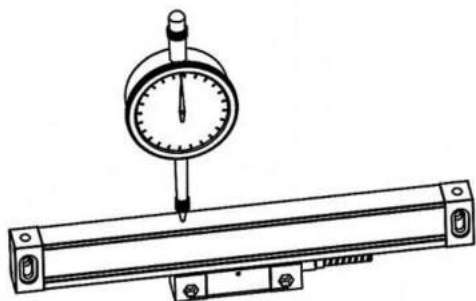

4.9

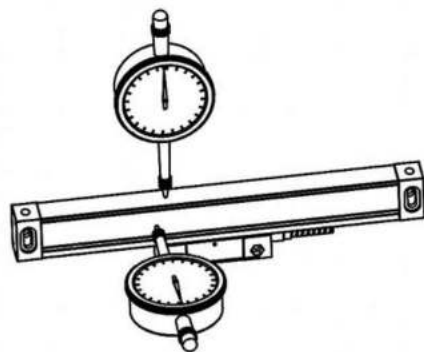

4.10

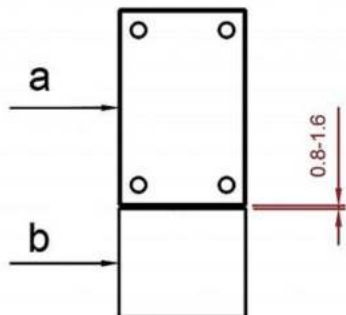

2. Cabezal de lectura lado A y cuerpo de la regla lado B.  
Desalineación en dirección horizontal.

$0,25 \pm 0,15$  mm

3. Paralelismo del cabezal de lectura con respecto a

Máquina herramienta  $<0,10$  mm, el máximo no puede superar los 0,30 mm

## Parámetro:

<b>Model</b>	<b>SNS-3V-YE102024</b>	<b>SNS-3V-YE161838</b>
<b>Rated voltage:</b>	CA 85-230 V 50 Hz/60 Hz	
<b>Resolution</b>	5 $\mu\text{m}$	
<b>Number of axes</b>	3	
<b>Range</b>	10 inches 20 inches 24 inches	16 inches 18 inches 38 inches

## Accesorios estándar:

<b>Accessories for digital display meters:</b>	<b>Accessories for grating ruler:</b>
<ol style="list-style-type: none"> <li>1. Support rod * 1</li> <li>2. Knife holder plate * 1</li> <li>3. Transparent watch case * 1</li> <li>4. Power cord * 1</li> <li>5. Watch holder * 1</li> <li>6. Butterfly piece * 2</li> <li>7. M8 * 70 screw * 1</li> <li>8. M10 * 55 screw * 1</li> <li>9. Nut M10 * 1</li> <li>10. Nut M8 * 1</li> <li>11. Nut M5 * 1</li> <li>12. Internal hexagonal screw M5 * 20 * 2</li> <li>13. Internal hexagonal screw M5 * 25 * 1</li> <li>14. M4 * hex socket screw * 4</li> <li>15. M5 * 10 machine meter screws * 2</li> <li>16. Washer <math>\phi</math> 10 * 1</li> <li>17. Washer <math>\phi</math> 8 * 1</li> <li>18. Washer <math>\phi</math> 5 * 1</li> <li>19. Rubber washer 20 * 10 * 1 * 1</li> <li>20. Rubber washer 20 * 10 * 0.5 * 1</li> <li>21. Spring washer <math>\phi</math> 10 * 1</li> <li>22. Spring washer <math>\phi</math> 8 * 1</li> <li>23. Spring washer <math>\phi</math> 5 * 1</li> </ol>	<ol style="list-style-type: none"> <li>1. Ruler cover * 3</li> <li>2. L mounting plate * 4</li> <li>3. Plug * 6</li> <li>4. Screw pack * 3 bags</li> </ol> <p>Each bag contains:</p> <p>Internal hexagonal screw M4 * 30 * 4;  Internal hexagonal screw M4 * 12 * 2;  Internal hexagonal screw M4 * 8 * 4;  U-shaped gasket T=0.2mm * 2;  Washer <math>\phi</math> 6 * 2;  Washer <math>\phi</math> 5 * 2;  Washer <math>\phi</math> 4 * 6;  Line card * 2</p>

Este dispositivo cumple con la Parte 15 de las Normas de la FCC. Su funcionamiento está sujeto a las dos condiciones siguientes: (1) Este dispositivo no puede causar interferencias perjudiciales y (2)

Este dispositivo debe aceptar cualquier interferencia que reciba, incluidas las interferencias que puedan causar un funcionamiento no deseado.

Fabricante: Shanghaimuxinmuyeyouxiangongsi

Dirección: Shuangchenglu 803nong11hao1602A-1609shi, baoshanqu, shanghai  
200000 CN.

Importado a Australia: SIHAO PTY LTD, 1 ROKEVA STREETEASTWOOD NSW  
2122 Australia

Importado a EE. UU.: Sanven Technology Ltd., Suite 250, 9166 Anaheim Place, Rancho  
Cucamonga, CA 91730



E-CrossStu GmbH

Mainzer Landstr.69, 60329 Fráncfort del Meno.



YH CONSULTING LIMITADA.

C/O YH Consulting Limited Oficina 147, Centurion House,  
Carretera de Londres, Staines-upon-Thames, Surrey, TW18 4AX

**VEVOR**®  
TOUGH TOOLS, HALF PRICE

Soporte técnico y certificado de garantía electrónica  
[www.vevor.com/support](http://www.vevor.com/support)

# VEVOR®

## TOUGH TOOLS, HALF PRICE

Wsparcie techniczne i certyfikat e-gwarancji

[www.vevor.com/support](http://www.vevor.com/support)

### INSTRUKCJA OBSŁUGI WYŚWIETLACZA DRO

MODEL: SNS-3V-YE102024 JEST NS-3V-YE161838

nadal staramy się dostarczać Państwu narzędzia w konkurencyjnych cenach.  
„zapisz połowę”, „Połowa ceny” lub inne podobne określenia używane przez nas oznaczają jedynie szacunkowe oszczędności, jakie możesz uzyskać kupując u nas określone narzędzia w porównaniu z niektórymi najlepszymi markami i niekoniecznie oznacza to, że obejmuje wszystkie kategorie narzędzi oferowanych przez nas.  
uprzejmie przypominamy o konieczności dokładnego sprawdzenia, czy składając u nas zamówienie, faktycznie oszczędzając połowę w porównaniu z najlepszymi markami.

**VEVOR**<sup>®</sup>  
TOUGH TOOLS, HALF PRICE

WYŚWIETLACZ DRO

MODEL: SNS-3V-YE102024 SNS-3V-YE161838



POTRZEBUJESZ POMOCY? SKONTAKTUJ SIĘ Z NAMI!!

Masz pytania dotyczące produktu? Potrzebujesz wsparcia technicznego? Nie wahaj się

Skontaktuj się z nami:

Wsparcie techniczne i certyfikat gwarancji elektronicznej  
[www.vevor.com/support](http://www.vevor.com/support)

To jest oryginalna instrukcja, proszę przeczytać wszystkie instrukcje w podręczniku ostrożnie przed rozpoczęciem użytkowania. VEVOR zastrzega sobie prawo do jednoznacznej interpretacji naszej instrukcji obsługi. Wygląd produktu podlega otrzymanemu produkt. Przepraszamy, że nie będziemy Cię już więcej informować, jeśli w naszym produkcie pojawią się jakiegokolwiek aktualizacje technologiczne lub oprogramowania.

Drodzy użytkownicy:

Dziękujemy za zakup wielofunkcyjnych cyfrowych wskaźników odczytu.

Odczyty cyfrowe są wykorzystywane w wielu różnych zastosowaniach. Obejmują one: narzędzia maszynowe, w osiach posuwu, urządzeniach pomiarowych i kontrolnych, EDM i stanowiskach aparaty dzielące, narzędzia do ustawiania, pomiarowych kontrola produkcji. Aby spełnić wymagania tych

W wielu zastosowaniach do odczytów cyfrowych można podłączyć wiele enkoderów.

Przed użyciem należy uważnie przeczytać wszystkie instrukcje zawarte w instrukcji.

Ścisłe ich przestrzegaj. Zachowaj instrukcję do wykorzystania w przyszłości.

uwaga dotycząca bezpieczeństwa:

⚠ Aby zapobiec porażeniu prądem elektrycznym lub pożarowi, wilgoci lub bezpośredniemu rozpyleniu należy unikać pływu chłodzącego. W przypadku jakiegokolwiek dymu lub osobliwego zapach z wyświetlacza cyfrowego, proszę odłączyć wtyczkę zasilającą natychmiast, w przeciwnym razie może dojść do pożaru lub porażenia prądem. W takim przypadku nie należy podejmować prób naprawy, lecz skontaktować się z firmą lub **distributors.**

⚠ Odczyt cyfrowy to precyzyjne urządzenie pomiarowe, stosowane za pomocą przyrządu optycznego. Skala liniowa · gdy jest używana, jeśli połączenie między

Skala liniowa i odczyt cyfrowy są uszkodzone lub uszkodzone

zewnątrznie mogą wystąpić nieprawidłowe wartości pomiarowe. Dlatego też, użytkownik powinien zachować ostrożność.

⚠ Nie należy podejmować prób naprawy lub modyfikacji wyświetlacza cyfrowego, gdyż może to spowodować awarię, może wystąpić błąd lub uraz. W przypadku jakichkolwiek nieprawidłowych warunków, Proszę skontaktować się z firmą lub dystrybutorem.

⚠ Jeżeli optyczna skala liniowa używana z odczytem cyfrowym jest uszkodzona, nie należy używać skali liniowej innej marki. Ponieważ wydajność, specyfikacja i połączenie produktów różnych i różnych marek różnią się w zależności od modelu, nie wolno podłączać bez instrukcji specjalistycznego personelu technicznego personelu, w przeciwnym razie mogą wystąpić problemy z odczytem cyfrowym.

⚠ **With the continuous updating of products, if there are changes or**

W przypadku zmian parametrów próbki, pierwszeństwo mają pliki losowe, a firma ma prawo do ostatecznej interpretacji bez wcześniejszego powiadomienia.

## Contents

---

1.	Illustration of Panel and keyboard .....	4
2.	Caption of the keyboard .....	5
3.	Parameters settings .....	7
3.1	Parameters setup routine entrance .....	7
3.2	Parameters Settings Description .....	7
3.2.1	Setting the Resolution .....	7
3.2.2	Setting Positive Direction for Counter .....	8
3.2.3	Toggle Between R/D Display Mode .....	8
3.2.4	Setting Z axis Dial .....	8
3.2.5	Setting the Rotary Radius of the Workpiece.....	9
3.2.6	Setting the Angle Display Mode .....	9
3.2.7	Setting the Baudrate of RS_232(optional) .....	9
3.2.8	Setting the Absolute Zeroing enable or disable .....	10
3.2.9	Setting the Absolute form the Special Function .....	10
3.2.10	Setting the Calculator display Mode.....	10
3.2.11	display brightness setting .....	10
3.2.12	The linear scale counting frequency setting .....	11
3.2.13	Setting QUIT .....	11
3.2.14	Setting the type of the DRO. ....	11
3.2.15	Signal Interface Type .....	11
3.2.16	Restore Factory Settings: .....	12
3.2.17	Shrinkage Ratio enable or disable.....	12
3.2.18	Setting Compensation Type .....	12
3.2.19	Inch display, set the number of digits after the decimal point...	13
3.2.20	Setting EDM(optional) .....	13
3.2.21	Setting Linearity Compensation. ....	13
3.2.22	Setting the Shrinkage Ratio .....	13
4.	General Operations .....	14
4.1	Zeroing.....	14
4.2	Preset Data to Designated Axis .....	14
4.3	Toggle Display Unit between inch and mm .....	14
4.4	Absolute/Incremental/200 groups SDM .....	15
4.5	1/2 Function .....	15
4.6	Clear All SDM Datum.....	16

## Contents

---

4.7 Sleeping Mode .....	16
4.8 Power Interruption Memory .....	16
4.9 Search the Absolute Reference Point of Scale .....	17
4.10 Non Linear Error Compensation .....	20
5、200 Groups SDM coordinate .....	21
5.1 Zeroing at the Current Point.....	21
5.2 Preset datum of SDM coordinate .....	22
6、Special Function.....	24
6.1 Circumference Holes Processing .....	25
6.2 Linear Holes Processing .....	28
6.3 ARC Processing .....	30
6.4 Oblique Processing .....	39
6.5 Slope Processng.....	43
6.6 Chamber Processing.....	44
6.7 The Tool Diameter Compensation Function .....	45
6.8 Digital Filter of the Grinding Machine .....	46
6.9 Lathe Function .....	47
6.9.1 200 sets TOOL Libs .....	47
6.9.2 Taper Function .....	48
6.9.3 R/D Function .....	49
6.9.4 Y + Z Function ( only applicable to : 3 axes Lathe).....	49
6.10 EDM.....	50
7、Calculator.....	56
8、Appendix .....	57

## Illustration of Panel and keyboard

## THREE AXIS PANEL

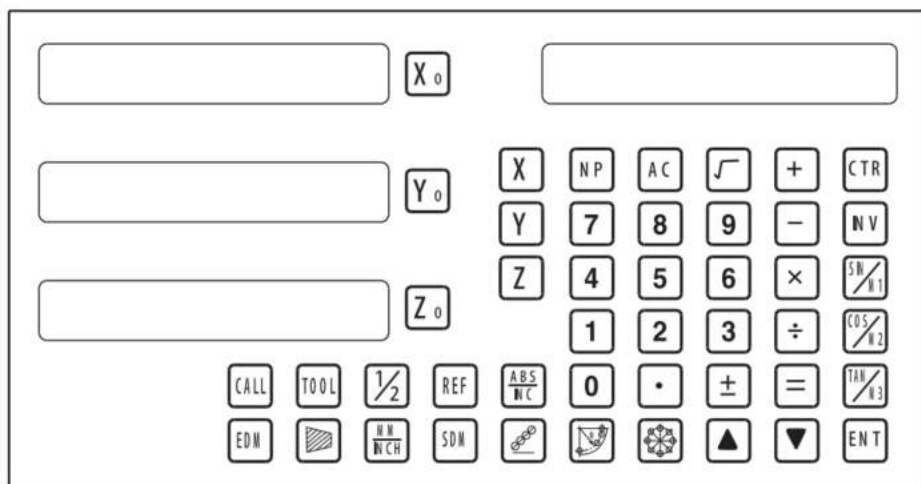



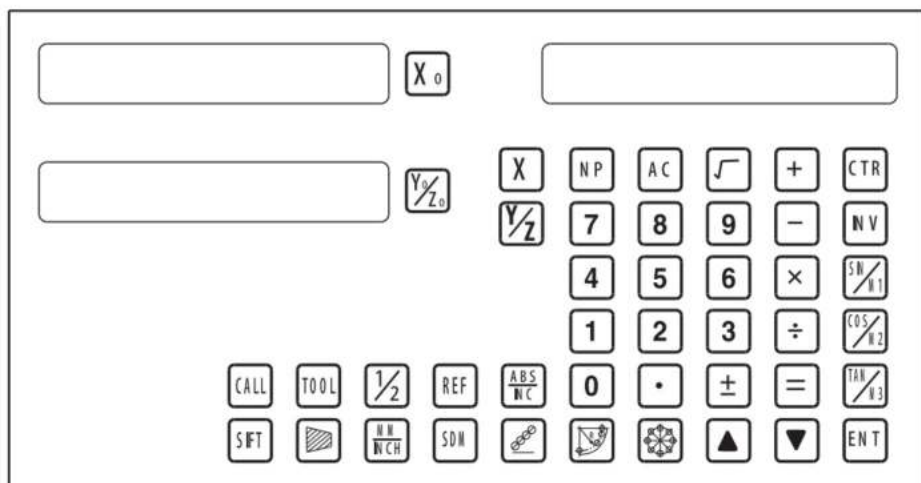































## TWO AXIS PANEL















## Caption of the keyboard

## Keyboard Description

  	Keys for axis selection
  	Zero select axis
	Enter +/- sign
	Enter decimal point
         	Entry keys for numbers
    	Operation key (in Calculation function key)
	Enter or quit calculating state
	Cancel incorrect operation
	Calculate inverse trigonometric
	Square root
	Confirm operation
	Toggles between inch and millimeter units.
	Press when ready to identify a reference mark.
	Function keys for 200 sub datum
	ARC cutting function
	holes displayed equally on a circle
	holes displayed equally on a line



## Caption of the keyboard





	Calculate trigonometric or Slope Processing function key
	Calculate trigonometric or rectangular inner chamber processing function key
	Calculate trigonometric or the tool diameter compensation function key
	Toggle between ABS/INC coordinate
	Stroll up or down to select
	Taper measured function key
	Tool library call key
	Opens the tool table.( lathe)
	EDM function key
	Filter display function key
	Half a display value of an axis
	Non Linear Error Compensation function keys

## Parameters settings

## 3. Parameters settings

## 3.1 Parameters setup routine entrance.

Press  to enter initial system and self-check after DRO powers on in 1 second, then Parameters settings display in the Parameters window. Press   to select the item you want to change.

If you want to quit initial setting, press   until "QUIT" appears in message window and press . You can also press  to quit initial setting.

## 3.2 Parameters Settings Description



## 3.2.1 Setting the Resolution

Press   until "RESOLUTE" appears in message window;

When selecting the LINEAR encode, the resolution will be set as follow:

There are 19 types of resolution:

0.01um;0.02um;0.05um;0.10um;0.20um;0.25um;0.50um;1.00um;  
2.00um;2.50um;5.00um;10.00um;20.00um;25.00um;50.00um;  
100.00um;200.00um;250.00um;500.00um.

Press  to change the resolution for X axis; Press  to change the resolution for Y axis; Press  to change the resolution for Z axis;

Set the resolution 5.00um to 1.00um for X axis:

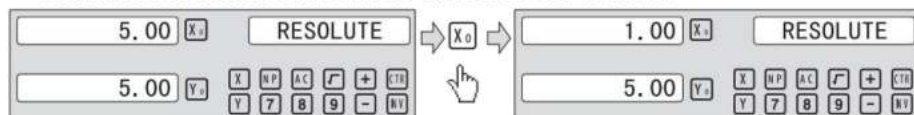

When selecting the rotary encode, the resolution will be set as follow:

Input the rotary encode parameter value .

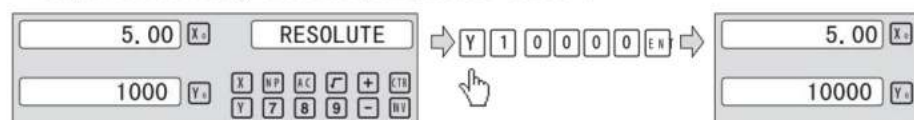

## Parameters settings

## 3.2.2 Setting Positive Direction for Counter

Press  $\blacktriangle$   $\blacktriangledown$  until “DIRECTE” appears in message window.

Direction ‘0’ means the display value will increase when scale moves from right to left and decrease when scale moves from left to right. Direction ‘1’ means the display value will increase when scale moves from left to right and decrease when scale moves from right to left.

Press  $X_0$  to change the Direction for X axis; Press  $Y_0$  to change the Direction for Y axis; Press  $Z_0$  to change the Direction for Z axis; as follow:

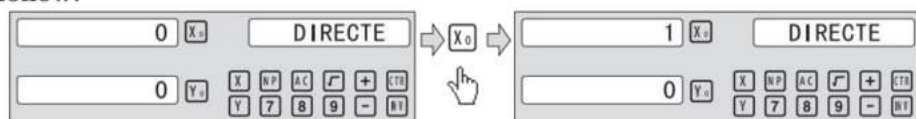

## 3.2.3 Toggle Between R/D Display Mode

Press  $\blacktriangle$   $\blacktriangledown$  until “R OR D” appears in message window. X window, Y window, Z window displays ‘0’ or ‘1’ separately.

‘0’ is mode R, which means the display value equals the actual measurement. ‘1’ is mode D where the display value equals the double actual measurement. Press  $X_0$  to change the R/D for X axis; Press  $Y_0$  to change the R/D for Y axis; Press  $Z_0$  to change the R/D for Z axis; as follow:

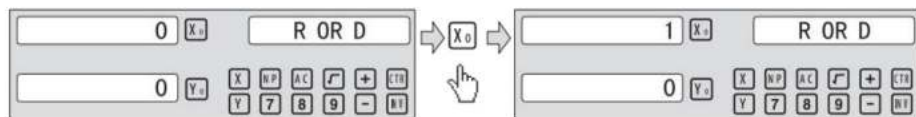

## 3.2.4 Setting Z axis Dial

Press  $\blacktriangle$   $\blacktriangledown$  until “Z DIAL” appears in message window.

Z axis dial should be set if Z axis is emulated for 2 axis milling and only install linear scale for X,Y axis. Z axis dial means the distance the Z axis travels when screw runs a revolution.

## Parameters settings

Set the Z axis Dial 2.5mm as follow ;



### 3.2.5 Setting the Rotary Radius of the Workpiece

Press **▲** **▼** until “RDIUS” appears in message window.

The Rotary radius type is used perimeter to measure angle.

Input the Rotary Radius parameter value 2000mm as follow:

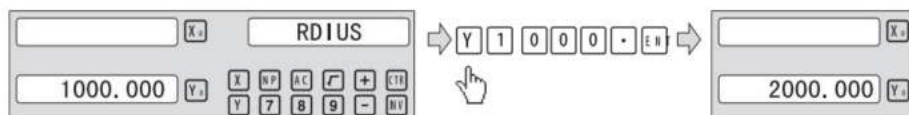

### 3.2.6 Setting the Angle Display Mode

Press **▲** **▼** until “ANG DISP” appears in message window.

Press **X<sub>0</sub>** to change the angle display mode for X axis; Press **Y<sub>0</sub>** to change the angle display mode for Y axis; Press **Z<sub>0</sub>** to change the angle display mode for Z axis; Example for X axis:

“0.0000” means the angle mode is Circulating DD;

“0000.0000” means the angle mode is Incremental DD;

“0.00.00” means the angle mode is Circulating DMS;

“0000.00.00” means the angle mode is Incremental DMS;

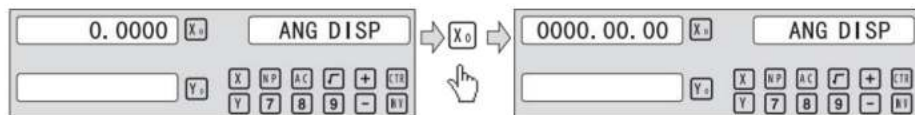

### 3.2.7 Setting the Baudrate of RS\_232 (Special customization function, if you need to buy, please contact the dealer to customize)

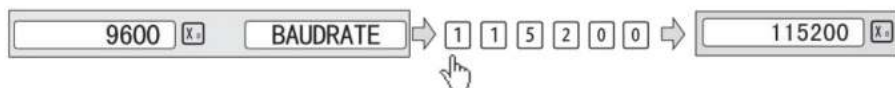

Press **▲** **▼** until “BAUDRATE” appears in message window.

Set the Baudrate 115200 as follow ;





## ustawienia parametrów

## 3.2.8 ustawienie włączania lub wyłączenia zerowania bezwzględnego



naciśnij   aż w oknie komunikatu pojawi się napis „ABS ZERO” .  
 „0” oznacza, że operacja zerowania ABS i ustawienia danych zostaną włącz w normalnym stanie wyświetlania .

„1” oznacza, że operacja zerowania ABS i ustawienia danych zostaną wyłącz w normalnym stanie wyświetlania .

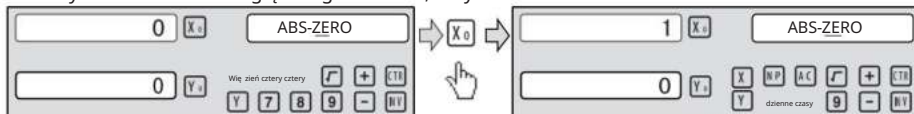
naciśnij  Aby zmienić tryb zerowania bezwzględnego dla osi X, naciśnij  aby zmienić tryb zerowania bezwzględnego dla osi Y, naciśnij  Do  
 zmien tryb zerowania bezwzględnego dla osi Z; Przykład dla osi X :



## 3.2.9 ustawienie formy absolutnej specjalnej funkcji



naciśnij   aż w oknie komunikatu pojawi się „ABS ASST” .  
 „0” oznacza, że wyświetlana jest tylko wartość pozycji specjalnej funkcji  
 Operacja specjalna.

„1” oznacza specjalną funkcję wartość pozycji + ABS Wartość pozycji  
 Wyświetl w operacji specjalnej Funkcji.

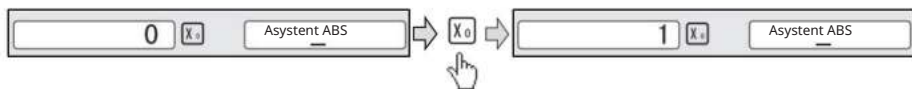
naciśnij  aby zmienić tryb absolutny dla funkcji specjalnej,  
 ustawić następująco:



## 3.2.10 ustawianie Calculator Tryb wyświetlania

naciśnij   dopóki w wiadomości W nie pojawi się napis „UCCTR MODE”  
 „0” wartość wyświetlana przez kalkulator w punkcie x oznacza wartość  
 wyświetlaną przez kalkulator w oknie komunikatu na wyświetlaczu;  
 naciśnij  aby zmienić tryb wyświetlania kalkulatora zostanie ustawiony jako

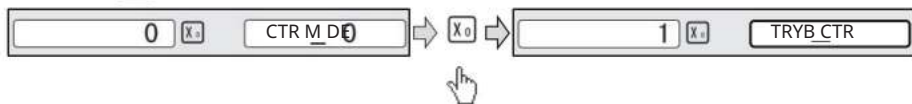

## 3.2.11 ustawienie jasności wyświetlacza

Ustawienie jasności wyświetlacza LED, domyślne ustawienie fabryczne to tylko „3”, im wyższy parametr, tym większa jasność. Naciśnij „x0”, aby  
 ustawić, nie zaleca się samodzielnego ustawiania wartości domyślnej.

## Parameters settings

## 3.2.12 The linear scale counting frequency setting

The factory default setting is only "12", the higher the parameter, the lower the counting frequency, press "X0" to set, it is not recommended that you set the default value yourself.

## 3.2.13 Setting QUIT: Digital display table parameters quit button.

## 3.2.14 Setting the type of the DRO.

The type of the DRO will be display on the right window. then press the key **ENT** to select the correct type. the following system item will be set:

"MILL-3" means the DRO type is 3-axis milling machine table;

"MILL-2" means the DRO type is 2-axis milling machine table;

"LATHE-2" means the DRO type is 2-axis lathe table;

"LATHE-3" means the DRO type is 3-axis lathe table;

"GRIND" means the DRO type is Grind table;

"EDM" means the DRO type is EDM table; (Special customization function, if you need to buy, please contact the dealer to customize)

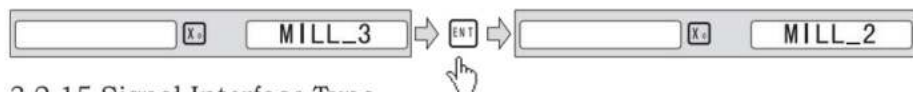

## 3.2.15 Signal Interface Type

Message window displays "SEL AXIS" which indicates the step is to Sensor input signal mode. Press **X0** to change the signal mode for X axis; Press **Y0** to change the signal mode for Y axis; Press **Z0** to change the signal mode for Z axis; Example for X axis:

Press **X0** to scroll through the Rotary encode type, the Linear encode type, the Rotary rdius type.

X window displays the Signal type.

"LInER" means the Signal type is linear encode type ;

"EnCoDE " means the Signal type is Rotary encode type;

"RdIUS" means the Signal type is Rotary rdius type ;

Example: currently in the linear encode type, to toggle to the Rotary encode type;

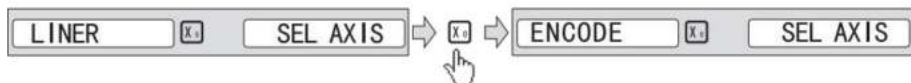

## Parameters settings

## 3.2.16 Restore Factory Settings:

Clear all data except DRO type.DRO will load default setup for parameter.After loading default setup,user must search RI once to enable resuming ABS datum function;otherwise to resume the datum by RI is unable;

Message window displays “ALL CLR”, press **ENT** and message windows display “PASSWORD” indicating the operator to input password; Press 2000 + **ENT** in turn to load default value;

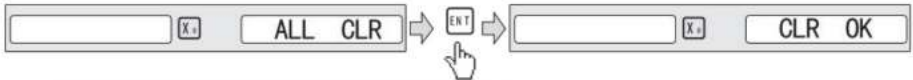

## 3.2.17 Shrinkage Ratio enable or disable.

Message window displays “SRK OFF” to disable Shrinkage rate function. Press **ENT** to enable Shrinkage rate function in Message window displays “SRK ON” :

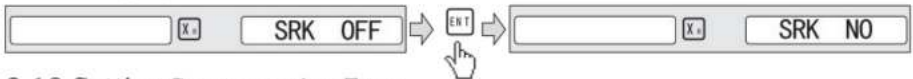

## 3.2.18 Setting Compensation Type

Message window displays “SEL COMP” which indicates the step is to compensation type. Press **X0** to change the compensation type for X axis;Press **Y0** to change the compensation type for Y axis;Press **Z0** to change the compensation type for Z axis;Example for X axis:

Press **X0** to scroll through the not compensation type, the Linear compensation type, the non-linear compensation type.

“no-CO” means the compensation type is not compensation type;

“LinE-CO” means the compensation type is linear compensation type.

“non-LinE” means the compensation type is non-linear linear compensation type;

Example for X axis: currently in the not compensation X type, to toggle to the linear compensation type;

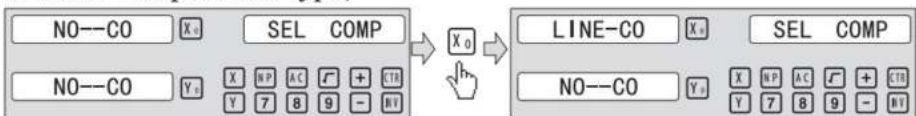

## Parameters settings

## 3.2.19 Inch display, set the number of digits after the decimal point

In the inch display mode, the number of digits after the decimal point is set, the factory default digit is "4", press "X0" to set, can be set according to actual needs.

3.2.20 Setting EDM: it is not recommended that you set the default value yourself, EDM function, Set the relay off on time.

## 3.2.21 Setting Linearity Compensation.

Message window displays "LIN COMP" which indicates the step is to Linearity Compensation. Compensate the linear error to make display value equals to standard value.

The calculation of compensation rectifying coefficient:

$$\text{Coefficient} = \frac{(\text{Measurement} - \text{Standard value}) \times 1000.000}{\text{Standard value}}$$

Example for X axis:

Measurement 200.020mm

Standard value 200.000mm

Rectifying coefficient= (200.020-200) \* 1000 /200 =-0.01mm/m

Input compensation rectifying coefficient 0.01 as follow:

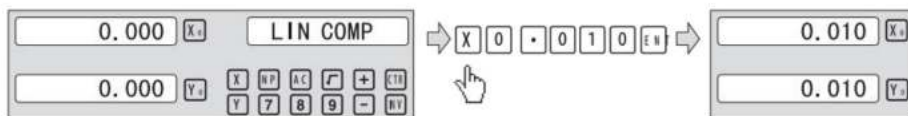

## 3.2.22 Setting the Shrinkage Ratio

Press until "SHRINK" appears in message window;

$$\text{Shrinkage ratio} = \frac{\text{Dimensions of the finished product}}{\text{Dimensions of the working piece}}$$

Set the shrinkage ratio 1.005 as follow;

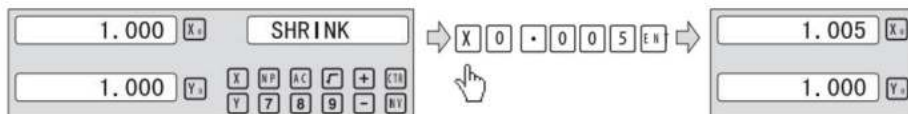







## General Operations

---

### 4、 General Operations;

#### 4.1 Zeroing









Zero the designated axis in normal display state. Zeroing is used to set the current position as datum point as follow;

key		<span style="border: 1px solid black; padding: 2px;">X<sub>0</sub></span>		X axis zero	<table style="width: 100%; border-collapse: collapse;"> <tr> <td style="width: 80%; border: 1px solid gray; padding: 2px;">0.000</td> <td style="width: 20%; border: 1px solid gray; padding: 2px;"><span style="border: 1px solid black; padding: 2px;">X<sub>0</sub></span></td> </tr> <tr> <td style="border: 1px solid gray; padding: 2px;">0.000</td> <td style="border: 1px solid gray; padding: 2px;"><span style="border: 1px solid black; padding: 2px;">Y<sub>0</sub></span></td> </tr> <tr> <td style="border: 1px solid gray; padding: 2px;">0.000</td> <td style="border: 1px solid gray; padding: 2px;"><span style="border: 1px solid black; padding: 2px;">Z<sub>0</sub></span></td> </tr> </table>	0.000	<span style="border: 1px solid black; padding: 2px;">X<sub>0</sub></span>	0.000	<span style="border: 1px solid black; padding: 2px;">Y<sub>0</sub></span>	0.000	<span style="border: 1px solid black; padding: 2px;">Z<sub>0</sub></span>
0.000	<span style="border: 1px solid black; padding: 2px;">X<sub>0</sub></span>										
0.000	<span style="border: 1px solid black; padding: 2px;">Y<sub>0</sub></span>										
0.000	<span style="border: 1px solid black; padding: 2px;">Z<sub>0</sub></span>										
key		<span style="border: 1px solid black; padding: 2px;">Y<sub>0</sub></span>		Y axis zero							
key		<span style="border: 1px solid black; padding: 2px;">Z<sub>0</sub></span>		Z axis zero							

X<sub>0</sub> or Y<sub>0</sub> or Z<sub>0</sub> will be return to the original data before the reset.

#### 4.2 Preset Data to Designated Axis



Preset a value to current position for a designated axis in normal display state.

<table style="width: 100%; border-collapse: collapse;"> <tr><td style="width: 80%; border: 1px solid gray; padding: 2px;">25.400</td><td style="width: 20%; border: 1px solid gray; padding: 2px;"><span style="border: 1px solid black; padding: 2px;">X<sub>0</sub></span></td></tr> <tr><td style="border: 1px solid gray; padding: 2px;">50.800</td><td style="border: 1px solid gray; padding: 2px;"><span style="border: 1px solid black; padding: 2px;">Y<sub>0</sub></span></td></tr> <tr><td style="border: 1px solid gray; padding: 2px;">76.200</td><td style="border: 1px solid gray; padding: 2px;"><span style="border: 1px solid black; padding: 2px;">Z<sub>0</sub></span></td></tr> </table>	25.400	<span style="border: 1px solid black; padding: 2px;">X<sub>0</sub></span>	50.800	<span style="border: 1px solid black; padding: 2px;">Y<sub>0</sub></span>	76.200	<span style="border: 1px solid black; padding: 2px;">Z<sub>0</sub></span>		 <span style="border: 1px solid black; padding: 2px;">X</span> 1 8 0 . 0 1 0 ENT 	<table style="width: 100%; border-collapse: collapse;"> <tr><td style="width: 80%; border: 1px solid gray; padding: 2px;">180.010</td><td style="width: 20%; border: 1px solid gray; padding: 2px;"><span style="border: 1px solid black; padding: 2px;">X<sub>0</sub></span></td></tr> <tr><td style="border: 1px solid gray; padding: 2px;">586.010</td><td style="border: 1px solid gray; padding: 2px;"><span style="border: 1px solid black; padding: 2px;">Y<sub>0</sub></span></td></tr> <tr><td style="border: 1px solid gray; padding: 2px;">888.660</td><td style="border: 1px solid gray; padding: 2px;"><span style="border: 1px solid black; padding: 2px;">Z<sub>0</sub></span></td></tr> </table>	180.010	<span style="border: 1px solid black; padding: 2px;">X<sub>0</sub></span>	586.010	<span style="border: 1px solid black; padding: 2px;">Y<sub>0</sub></span>	888.660	<span style="border: 1px solid black; padding: 2px;">Z<sub>0</sub></span>
25.400	<span style="border: 1px solid black; padding: 2px;">X<sub>0</sub></span>														
50.800	<span style="border: 1px solid black; padding: 2px;">Y<sub>0</sub></span>														
76.200	<span style="border: 1px solid black; padding: 2px;">Z<sub>0</sub></span>														
180.010	<span style="border: 1px solid black; padding: 2px;">X<sub>0</sub></span>														
586.010	<span style="border: 1px solid black; padding: 2px;">Y<sub>0</sub></span>														
888.660	<span style="border: 1px solid black; padding: 2px;">Z<sub>0</sub></span>														
<table style="width: 100%; border-collapse: collapse;"> <tr><td style="width: 80%; border: 1px solid gray; padding: 2px;">50.800</td><td style="width: 20%; border: 1px solid gray; padding: 2px;"><span style="border: 1px solid black; padding: 2px;">Y<sub>0</sub></span></td></tr> <tr><td style="border: 1px solid gray; padding: 2px;">76.200</td><td style="border: 1px solid gray; padding: 2px;"><span style="border: 1px solid black; padding: 2px;">Z<sub>0</sub></span></td></tr> </table>	50.800	<span style="border: 1px solid black; padding: 2px;">Y<sub>0</sub></span>	76.200	<span style="border: 1px solid black; padding: 2px;">Z<sub>0</sub></span>		 <span style="border: 1px solid black; padding: 2px;">Y</span> 5 8 6 . 0 1 0 ENT 	<table style="width: 100%; border-collapse: collapse;"> <tr><td style="width: 80%; border: 1px solid gray; padding: 2px;">180.010</td><td style="width: 20%; border: 1px solid gray; padding: 2px;"><span style="border: 1px solid black; padding: 2px;">X<sub>0</sub></span></td></tr> <tr><td style="border: 1px solid gray; padding: 2px;">586.010</td><td style="border: 1px solid gray; padding: 2px;"><span style="border: 1px solid black; padding: 2px;">Y<sub>0</sub></span></td></tr> <tr><td style="border: 1px solid gray; padding: 2px;">888.660</td><td style="border: 1px solid gray; padding: 2px;"><span style="border: 1px solid black; padding: 2px;">Z<sub>0</sub></span></td></tr> </table>	180.010	<span style="border: 1px solid black; padding: 2px;">X<sub>0</sub></span>	586.010	<span style="border: 1px solid black; padding: 2px;">Y<sub>0</sub></span>	888.660	<span style="border: 1px solid black; padding: 2px;">Z<sub>0</sub></span>		
50.800	<span style="border: 1px solid black; padding: 2px;">Y<sub>0</sub></span>														
76.200	<span style="border: 1px solid black; padding: 2px;">Z<sub>0</sub></span>														
180.010	<span style="border: 1px solid black; padding: 2px;">X<sub>0</sub></span>														
586.010	<span style="border: 1px solid black; padding: 2px;">Y<sub>0</sub></span>														
888.660	<span style="border: 1px solid black; padding: 2px;">Z<sub>0</sub></span>														
<table style="width: 100%; border-collapse: collapse;"> <tr><td style="width: 80%; border: 1px solid gray; padding: 2px;">76.200</td><td style="width: 20%; border: 1px solid gray; padding: 2px;"><span style="border: 1px solid black; padding: 2px;">Z<sub>0</sub></span></td></tr> </table>	76.200	<span style="border: 1px solid black; padding: 2px;">Z<sub>0</sub></span>		 <span style="border: 1px solid black; padding: 2px;">Z</span> 8 8 8 . 6 6 0 ENT 	<table style="width: 100%; border-collapse: collapse;"> <tr><td style="width: 80%; border: 1px solid gray; padding: 2px;">180.010</td><td style="width: 20%; border: 1px solid gray; padding: 2px;"><span style="border: 1px solid black; padding: 2px;">X<sub>0</sub></span></td></tr> <tr><td style="border: 1px solid gray; padding: 2px;">586.010</td><td style="border: 1px solid gray; padding: 2px;"><span style="border: 1px solid black; padding: 2px;">Y<sub>0</sub></span></td></tr> <tr><td style="border: 1px solid gray; padding: 2px;">888.660</td><td style="border: 1px solid gray; padding: 2px;"><span style="border: 1px solid black; padding: 2px;">Z<sub>0</sub></span></td></tr> </table>	180.010	<span style="border: 1px solid black; padding: 2px;">X<sub>0</sub></span>	586.010	<span style="border: 1px solid black; padding: 2px;">Y<sub>0</sub></span>	888.660	<span style="border: 1px solid black; padding: 2px;">Z<sub>0</sub></span>				
76.200	<span style="border: 1px solid black; padding: 2px;">Z<sub>0</sub></span>														
180.010	<span style="border: 1px solid black; padding: 2px;">X<sub>0</sub></span>														
586.010	<span style="border: 1px solid black; padding: 2px;">Y<sub>0</sub></span>														
888.660	<span style="border: 1px solid black; padding: 2px;">Z<sub>0</sub></span>														



#### 4.3 Toggle Display Unit between inch and mm

Length can be displayed either in “mm” (metric) or “inch” (imperial). Display unit can be toggled between mm and inch.

Example: Display value toggle from mm to inch;

<table style="width: 100%; border-collapse: collapse;"> <tr><td style="width: 80%; border: 1px solid gray; padding: 2px;">25.400</td><td style="width: 20%; border: 1px solid gray; padding: 2px;"><span style="border: 1px solid black; padding: 2px;">X<sub>0</sub></span></td></tr> <tr><td style="border: 1px solid gray; padding: 2px;">50.800</td><td style="border: 1px solid gray; padding: 2px;"><span style="border: 1px solid black; padding: 2px;">Y<sub>0</sub></span></td></tr> <tr><td style="border: 1px solid gray; padding: 2px;">76.200</td><td style="border: 1px solid gray; padding: 2px;"><span style="border: 1px solid black; padding: 2px;">Z<sub>0</sub></span></td></tr> </table>	25.400	<span style="border: 1px solid black; padding: 2px;">X<sub>0</sub></span>	50.800	<span style="border: 1px solid black; padding: 2px;">Y<sub>0</sub></span>	76.200	<span style="border: 1px solid black; padding: 2px;">Z<sub>0</sub></span>	mm 		inch		<table style="width: 100%; border-collapse: collapse;"> <tr><td style="width: 80%; border: 1px solid gray; padding: 2px;">1.0000</td><td style="width: 20%; border: 1px solid gray; padding: 2px;"><span style="border: 1px solid black; padding: 2px;">X<sub>0</sub></span></td></tr> <tr><td style="border: 1px solid gray; padding: 2px;">2.0000</td><td style="border: 1px solid gray; padding: 2px;"><span style="border: 1px solid black; padding: 2px;">Y<sub>0</sub></span></td></tr> <tr><td style="border: 1px solid gray; padding: 2px;">3.0000</td><td style="border: 1px solid gray; padding: 2px;"><span style="border: 1px solid black; padding: 2px;">Z<sub>0</sub></span></td></tr> </table>	1.0000	<span style="border: 1px solid black; padding: 2px;">X<sub>0</sub></span>	2.0000	<span style="border: 1px solid black; padding: 2px;">Y<sub>0</sub></span>	3.0000	<span style="border: 1px solid black; padding: 2px;">Z<sub>0</sub></span>
25.400	<span style="border: 1px solid black; padding: 2px;">X<sub>0</sub></span>																
50.800	<span style="border: 1px solid black; padding: 2px;">Y<sub>0</sub></span>																
76.200	<span style="border: 1px solid black; padding: 2px;">Z<sub>0</sub></span>																
1.0000	<span style="border: 1px solid black; padding: 2px;">X<sub>0</sub></span>																
2.0000	<span style="border: 1px solid black; padding: 2px;">Y<sub>0</sub></span>																
3.0000	<span style="border: 1px solid black; padding: 2px;">Z<sub>0</sub></span>																

Example: Display value toggle from inch to mm;

<table style="width: 100%; border-collapse: collapse;"> <tr><td style="width: 80%; border: 1px solid gray; padding: 2px;">1.0000</td><td style="width: 20%; border: 1px solid gray; padding: 2px;"><span style="border: 1px solid black; padding: 2px;">X<sub>0</sub></span></td></tr> <tr><td style="border: 1px solid gray; padding: 2px;">2.0000</td><td style="border: 1px solid gray; padding: 2px;"><span style="border: 1px solid black; padding: 2px;">Y<sub>0</sub></span></td></tr> <tr><td style="border: 1px solid gray; padding: 2px;">3.0000</td><td style="border: 1px solid gray; padding: 2px;"><span style="border: 1px solid black; padding: 2px;">Z<sub>0</sub></span></td></tr> </table>	1.0000	<span style="border: 1px solid black; padding: 2px;">X<sub>0</sub></span>	2.0000	<span style="border: 1px solid black; padding: 2px;">Y<sub>0</sub></span>	3.0000	<span style="border: 1px solid black; padding: 2px;">Z<sub>0</sub></span>	inch 		mm		<table style="width: 100%; border-collapse: collapse;"> <tr><td style="width: 80%; border: 1px solid gray; padding: 2px;">25.400</td><td style="width: 20%; border: 1px solid gray; padding: 2px;"><span style="border: 1px solid black; padding: 2px;">X<sub>0</sub></span></td></tr> <tr><td style="border: 1px solid gray; padding: 2px;">50.800</td><td style="border: 1px solid gray; padding: 2px;"><span style="border: 1px solid black; padding: 2px;">Y<sub>0</sub></span></td></tr> <tr><td style="border: 1px solid gray; padding: 2px;">76.200</td><td style="border: 1px solid gray; padding: 2px;"><span style="border: 1px solid black; padding: 2px;">Z<sub>0</sub></span></td></tr> </table>	25.400	<span style="border: 1px solid black; padding: 2px;">X<sub>0</sub></span>	50.800	<span style="border: 1px solid black; padding: 2px;">Y<sub>0</sub></span>	76.200	<span style="border: 1px solid black; padding: 2px;">Z<sub>0</sub></span>
1.0000	<span style="border: 1px solid black; padding: 2px;">X<sub>0</sub></span>																
2.0000	<span style="border: 1px solid black; padding: 2px;">Y<sub>0</sub></span>																
3.0000	<span style="border: 1px solid black; padding: 2px;">Z<sub>0</sub></span>																
25.400	<span style="border: 1px solid black; padding: 2px;">X<sub>0</sub></span>																
50.800	<span style="border: 1px solid black; padding: 2px;">Y<sub>0</sub></span>																
76.200	<span style="border: 1px solid black; padding: 2px;">Z<sub>0</sub></span>																

## General Operations

### 4.4 Absolute/Incremental/200 groups SDM

**Function:** The DRO has 3 coordinate display modes: the absolute mode (ABS); the incremental mode (INC) and 200 groups Second Data Memory (SDM) with the range of 00 to 99. Zero point of work-piece is set at the origin point of ABS coordinate. The relative distance between datum of ABS and SDM remains unchanged when ABS datum is changed.

1. Toggle from ABS to INC coordinate;

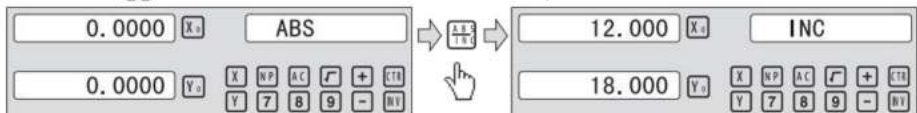

2. Toggle from INC to ABS coordinate;

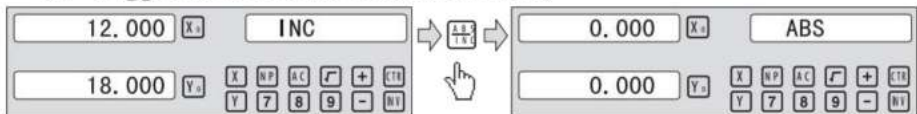

3. Toggle from SMD to ABS coordinate;

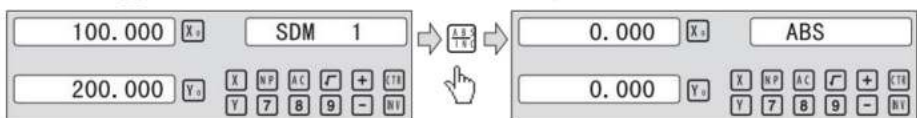

### 4.5 1/2 Function

**Function:** Set the center of work piece as datum by halving the displayed value.



**Example:** Set the center of rectangle as datum as the right figure.

**Steps:**

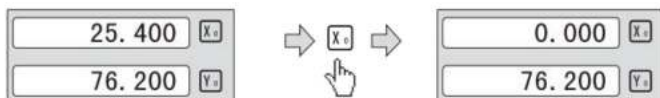
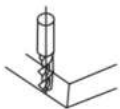
1. Touch one side of the workpiece with the TOOL, then zero the X axis.



2 , Przenieś NARZĘDZIE na przeciwną stronę przedmiotu obrabianego i dotknij go.

Następnie naciśnij  +  z kolei, aby wyświetlić wartość na osi X.

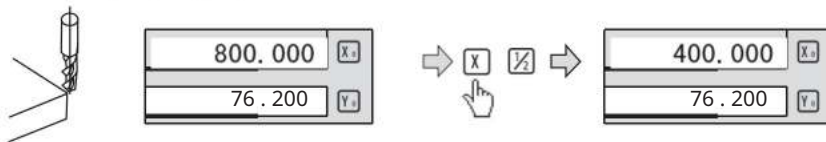

3 Przesuń tabelę motyłów, aż na osi x wyświetli się „o. 000” okno. Pozycja jest środkiem obrabianego przedmiotu.

4. 6 Wyczyść wszystkie dane SDM.

W trybie ABS, aby nacisnąć w sposób ciągły  dziesięć razy spowoduje wyczyszczenie wszystkich danych dla 200 zestawów SDM. Okno Message wyświetla "CLR".

4. 7 Tryb uśpienia

w trybie innym niż ABS, naciśnij te klawisze   Wyłącz wszystkie wyświetlacze

i DRO uzyskując dostęp do trybu uśpienia, a następnie naciskając ten klawisz ponownie spowoduje powrót DRO do trybu roboczego. W trybie uśpienia Tryb DRO jest nadal w stanie roboczym i faktycznie rejestruje NARZĘDZIE **movement.**

Przykład: W trybie innym niż ABS, aby uzyskać dostęp do trybu uśpienia, naciśnij klawisz F. W trybie uśpienia naciśnij te klawisze F powoduje wyjście z trybu 

Tryb uśpienia ·

4. 8 Pamięć przerwania zasilania.

Pamięć służy do przechowywania ustawień DRO i maszyny wartości odniesienia przy wyłączonym zasilaniu.

## Operacje ogólne

## 4.9 wyszukaj bezwzględny punkt odniesienia skali

W codziennym procesie obróbki bardzo często zdarza się, że obróbka nie może zostać ukończona w ciągu jednej zmiany roboczej, stąd DRO musi zostać wyłączony po pracy, a przerwa w dostawie prądu może nastąpić w trakcie Proces obróbki, który prowadzi do utraty punktu odniesienia przedmiotu obrabianego (pozycja zerowa przedmiotu obrabianego), ponowne ustalenie punktu odniesienia przedmiotu obrabianego używanie urządzenia do wyszukiwania krawędzi lub innej metody nieuchronnie powoduje wyższe obróbka z dokładnością, ponieważ nie jest możliwe ponowne ustalenie punkt odniesienia obrabianego przedmiotu dokładnie w poprzedniej pozycji. ABY umożliwić odzyskiwanie punktu odniesienia obrabianego przedmiotu z dużą dokładnością i bez konieczności ponownego ustalania punktu odniesienia obrabianego przedmiotu za pomocą czujnika krawędzi lub innych metod, każda skala liniowa ma punkt odniesienia, który jest wyposażony w punkt odniesienia pozycja zapewniająca funkcję pamięci punktu odniesienia.

Zasada działania funkcji pamięci danych odniesienia jest następująca: następuje.

ponieważ punkt odniesienia skali liniowej jest stały i ustalony, będzie nigdy się nie zmieniają i nie znikają po wyłączeniu systemu DRO. Dlatego musimy po prostu zapisać odległość między punktem odniesienia i punktem odniesienia przedmiotu obrabianego (pozycja zerowa) w pamięci NIEUlotnej. Następnie w przypadku awarii zasilania lub wyłączenia DRO możemy odzyskać punkt odniesienia obrabianego przedmiotu (pozycja zerowa) poprzez wstępne ustawienie zera wyświetlacza pozycja jako zapisana odległość od punktu odniesienia.

Podczas obróbki przedmiotu obrabianego należy ustalić punkt odniesienia bezwzględny. Dostępne są trzy tryby pracy (REF, AB, LEF AB):

Przykład: aby zapisać punkt odniesienia osi X

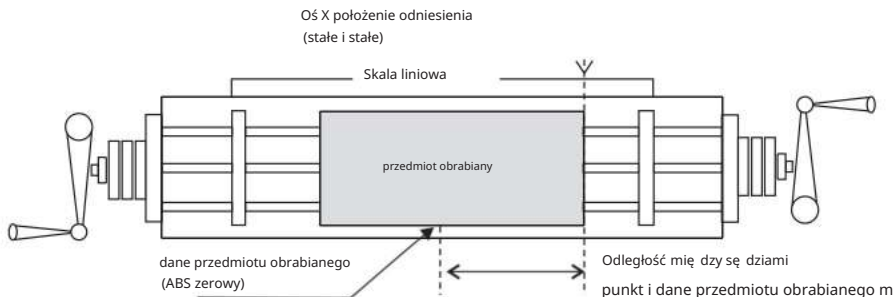

## General Operations

### Example for REF mode :

1、DRO is set in ABS coordinate. Press **REF**, then the message window display “REF” .

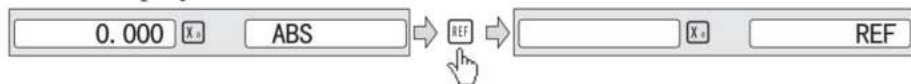

2、Message window displays “REF” , Press **ENT** until “FD\_REF” appears in message window.



3、Select the axis which need search RI. For instance : select X axis, then press **X** . “X\_REF” is displayed in message window, and X axis window flashes.

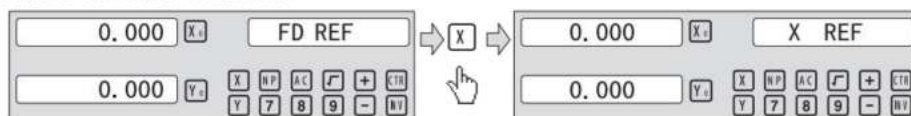

4、Move the machine table .The buzzer sounds when RI is searched, then X window stops flashing and displays the value of the current position .the DRO returns normal display state. Then message window displays “FIND\_X” .

### Example for AB mode :

1、DRO is set in ABS coordinate. Press **REF**, then the message window display “REF” .



2、Press **▲** **▼**, then the message window display “AB” .

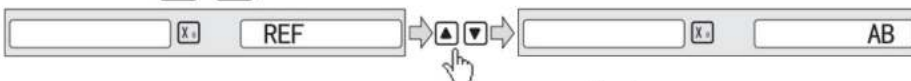

3、Message window displays “AB” , Press **ENT** until “FIND\_AB” appears in message window.

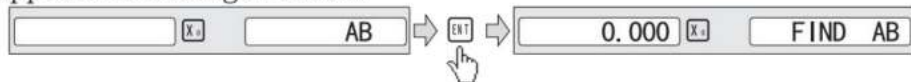

## General Operations

4、 Select the axis which need search RI. For instance : selct X axis, then press **X** . “X\_REF” is displayed in message window, and X axis window flashes.

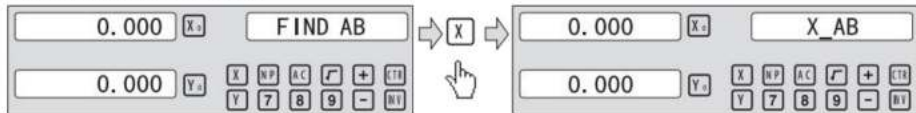

5、 Move the machine table .The buzzer sounds when RI is searched, displays the value of the current position for the absolute datum zero. the DRO returns normal display state. Then message window displays “FIND\_AB” .

### Example for LEF\_AB mode :

1、 DRO is set in ABS coordinate. Press **REF** , then the message window display “REF” .

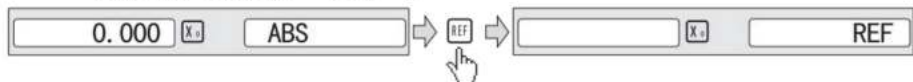

2、 Press **▲** **▼** , then the message window display “AB” .

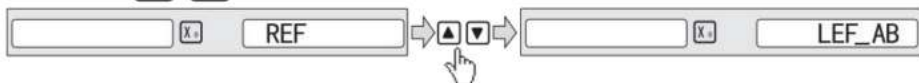

3、 Message window displays “LEF\_AB” , Press **ENT** until “ZERO\_AB” appears in message window.

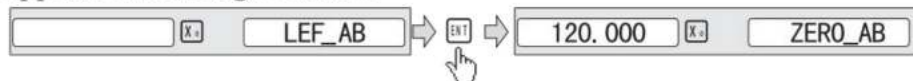

4、 Move the machine table to be set zero position piont. then press **X** , X axis will be zeroing . the current position for the absolute datum zero. the DRO returns normal display state.

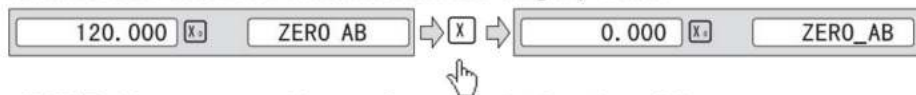

NOTE: Linear range without reference point location of the user

## General Operations

### 4.10 Non Linear Error Compensation

First compensation Type ( Linear or Non-Linear) in parameter setting must be set Non-Linear. Linear scale have a ref point location and find to the Absolute Reference Point will be enable.

Default Non-Linear compensation : 50.

#### Example for Y axis:

Step 1: Search the Absolute Reference Point of Scale;

Step 2: Press **[NP]** , then the message window display “COMP X” .



Step 3: Press **[▲]** **[▼]**, then the message window display “COMP Y”



Step 4: Press **[ENT]**, then the message window display “NUMBER” .

Then input the compensation parameter NUMBER.



Step 5: Press **[▲]** **[▼]**, then message window displays “Y-MSN-1” which indicates the step is to Non Linear Error Compensation.

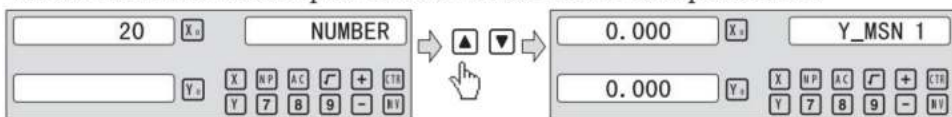

Step 6: Input compensation value .

X window display the value of the measurement value.

Y window display the value of the standard value.

Example for the first compensation point:

Measurement value :68.288mm. Standard value: 68.200mm



Step 7: After input all parameter, the DRO automatically exit.



2、 Set the point sdm1 as the datum of SDM 1. Move the machine worktable to  $x = 60.000$ ,  $y = 45.000$ . Then proess  $X_0$   $Y_0$ .

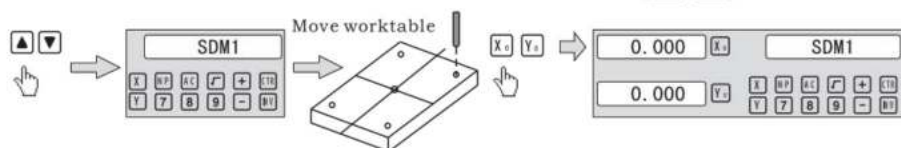

2、 Set the point sdm1 as the datum of SDM 2. Move the machine worktable to  $x = 60.000$ ,  $y = -45.000$ . Then proess  $X_0$   $Y_0$ .

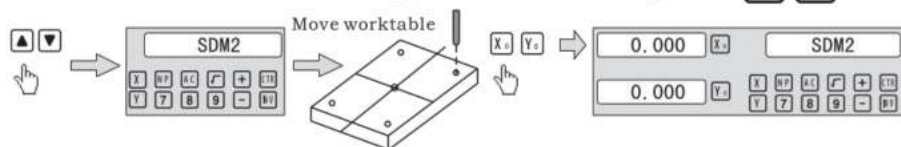

3、 Set the point sdm1 as the datum of SDM 3. Move the machine worktable to  $x = -60.000$ ,  $y = -45.000$ . Then proess  $X_0$   $Y_0$ .

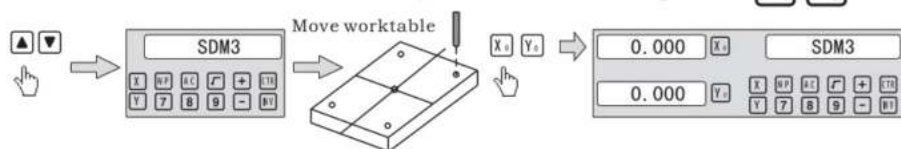

4、 Set the point sdm1 as the datum of SDM 4. Move the machine worktable to  $x = -60.000$ ,  $y = 45.000$ . Then proess  $X_0$   $Y_0$ .

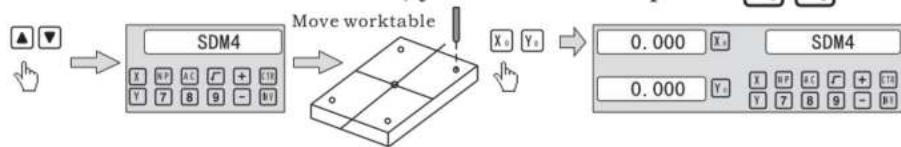

## 5.2 Preset datum of SDM coordinate

There are the same sample as Method 1. First Move the worktable to place the TOOL exactly at the origin of ABS, secondly Enter the ABS Mode as follow.

### Steps:

1、 Move worktable to place the TOOL at the center of the workpiece point O as the datum of ABS. Then zero X axis and Y axis in SDM 1 ; Zero X axis and Y axis in SDM 2 ; Zero X axis and Y axis in SDM 3 ; Zero X axis and Y axis in SDM 4.

## 200 Groups SDM coordinate

2、 Set point sdm1 as the datum of SDM 1. Press  $\blacktriangle$   $\blacktriangledown$ , then the message window display “SDM 1” . Input  $x = 60.000$ ,  $y = 45.000$ .

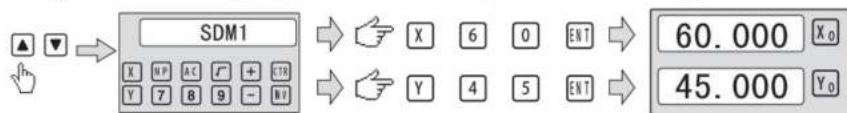

3、 Set point sdm1 as the datum of SDM 2. Press  $\blacktriangle$   $\blacktriangledown$ , then the message window display “SDM 2” . Input  $x = -60.000$ ,  $y = 45.000$ .

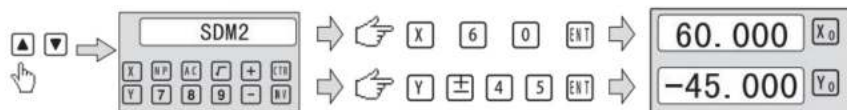

4、 Set point sdm1 as the datum of SDM 3. Press  $\blacktriangle$   $\blacktriangledown$ , then the message window display “SDM 3” . Input  $x = -60.000$ ,  $y = -45.000$ .

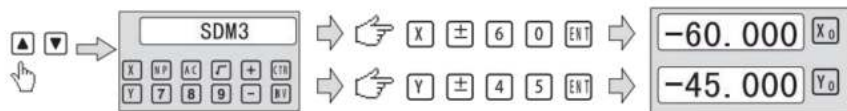

5、 Set point sdm1 as the datum of SDM 4. Press  $\blacktriangle$   $\blacktriangledown$ , then the message window display “SDM 4” . Input  $x = -60.000$ ,  $y = 45.000$ .

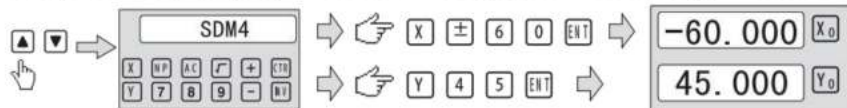

## 6, funkcja specjalna

## Circumference Holes Processing

### 6.1 Circumference Holes Processing

The Function of PCD Hole positioning on Circumference is used to distribute arc equally, such as boring hole on flange. The right window will show the parameter to be defined when selecting PCD Function.

The Parameters to be defined are:

PCD_XY(XZ,YZ)	Select place
CENTER	Center position
DIA	Diameter of circle
NO_HOLE	Hole number
ST ANG	Starting angle
ED ANG	Ending angle

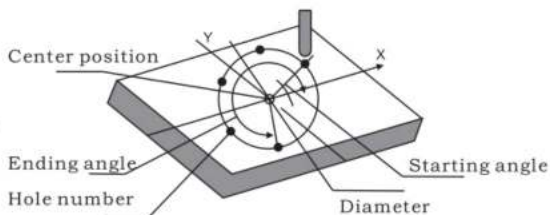

The position of the hole center are calculated automatically after input all parameters. Press or to choose the hole No. and move the machine table until the “0.000” appears in X window , Y window, Z window. It is the position to process a table.

Example for the XY place: Machine hole on circumference as the figure

PCD_XY(XZ,YZ)	XY
CENTER	X=0,000,Y=0.000
DIA	100,000
NO_HOLE	5
ST ANG	30,000
ED ANG	315,000

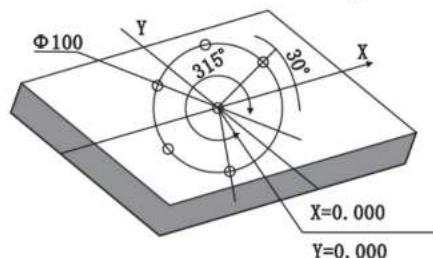

Steps:

1. Set display unit to metric in normal state; Move the machine table until the machine TOOL is aligned with the center of the circle , then zero X axis ,Y axis.

2. Select place.

Press , then the message window display “PCD\_XY” to the Circumference Holes Processing. Press or to select XY place.



## Circumference Holes Processing

## 2. Input center position.

Press **ENT**, then the message window display “CENTER”. X and Y window displays the formerly preset center position. Input X = 0, Y = 0 as follow.

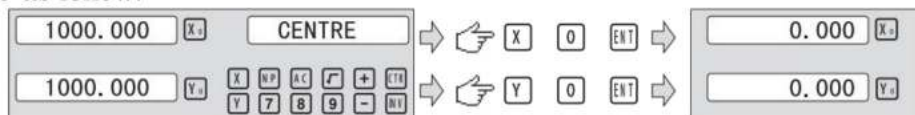

## 4. Input diameter.

Press **▼** until “DIA” appears in the message window. X window displays the formerly preset diameter. Then input the diameter is 100.000.

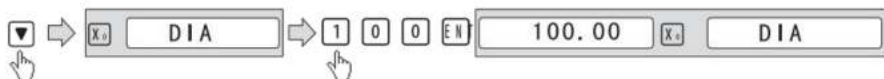

## 5. Input number.

Press **▼** until “NO\_HOLE” appears in the message window. X window displays the formerly preset number. Then press **5** in turn to input number.



## 6. Input starting angle.

Press **▼** until “ST ANG” appears in the message window. X window displays the formerly preset the starting angle. Then press **30** in turn to input the starting angle.



## 7. Input ending angle.

Press **▼** until “ED ANG” appears in the message window. X window displays the formerly preset the ending angle.. Then press **315** in turn to input the ending angle.

## Circumference Holes Processing



8. Press  until “NO 1” appears in the message window.

It is the position of the first hole to punch where the “0.000” is displayed in X window and Y window by moving the machine table.

After finishing the first hole, press  or  to change holes number.

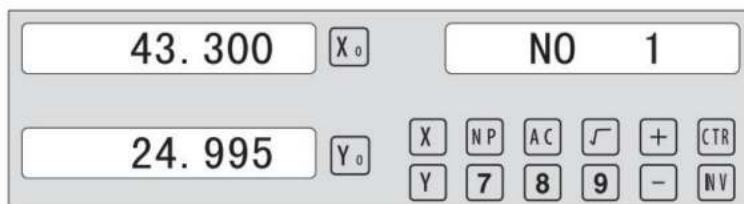

9. After processing all holes, press  to return normal display.

## Linear Holes Processing

### 6.2 Linear Holes Processing

There are two modes to carry out the linear drilling: Length mode and Step mode.

1.LINE S	Step mode
LINE L	Length mode
2.STEP	Step length
LENGTH	Line length
3. ANG	Angle
4. NO.HOLE	Hole number

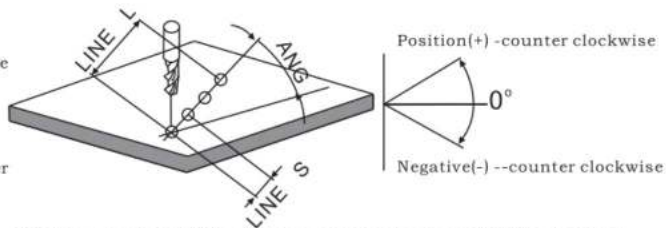

Linear Holes function can simplify the processing multiple holes whose centers are attributed equally on one line.

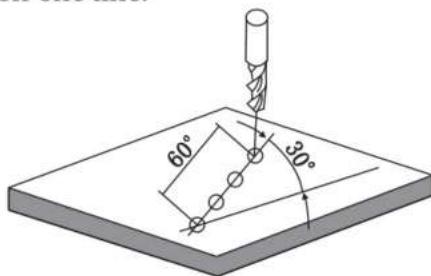

Example :

LINE_L	Length mode
LENGTH	60.000
ANG	30.000
NO.HOLE	4





Steps :

1. Select piece.

Press , then the message window display "LINE\_XY" to the Linear Holes Processing. Press  or  to select XY place.



2. Select Linear Holes mode.

Press , then the message window display "LINE\_S". Press  or  to select "LINE\_L".

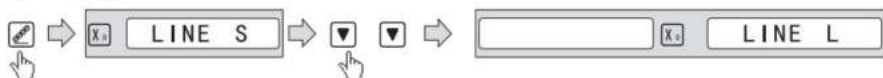

3. Input linear length;

Press , then the message window display "LENGTH".

## Linear Holes Processing

X window displays the formerly preset the linear length. Press **6** **0** in turn to input the linear length.

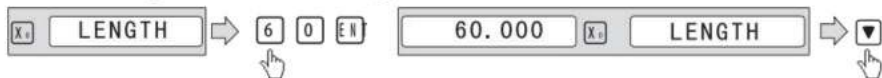

## 4. Input angle;

Message window displays “ANG” which indicates the step is to angle. X window displays the formerly preset the angle. Press **3** **0** in turn to input the angle.

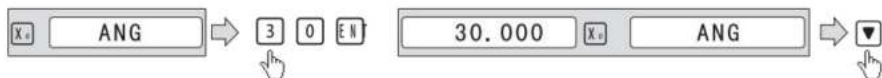

## 5. Input number;

Message window displays “ANG” which indicates the step is to angle. X window displays the formerly preset the number. Press **4** in turn to input the number.

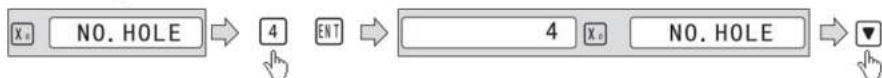

6. Press **▼** until “NO 1” appears in the message window.

It is the position of the first hole to punch where the “0.000” is displayed in X window and Y window by moving the machine table. After finishing the first hole, press **▲** or **▼** to change holes number.

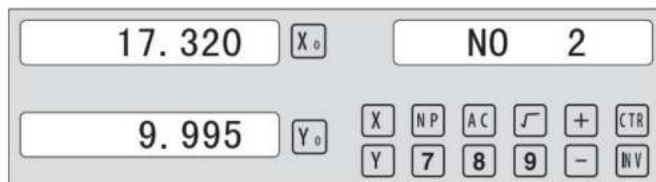

7. After processing all holes, press **☒** to return normal display.

## 6.3 Przetwarzanie ARC

Dla funkcji ARC dostępne są DWIE funkcje: prosta ARC

Funkcja i gładka funkcja R · naciśnij, a następnie przycisk  aby wejść do funkcji ARC,

 Lub  do wyboru funkcji gładkiego łuku lub prostego

Funkcja ARC.

Podczas instalacji zazwyczaj określa się współrzędne maszyny i kierunek X, Y, Z są następnie pułapki. Płaszczyzna robocza jest pokazana JAKO prawa figura.

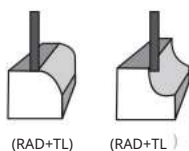

Z(+kierunek dodatni)

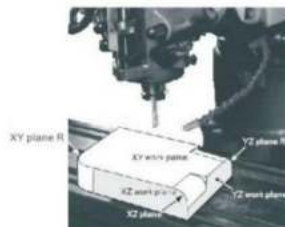
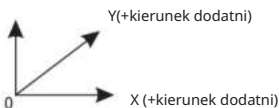

prosta funkcja ARC:

gdy gładkość nie jest bardzo pożądana, ŁUK PROSTY

Funkcja jest normalnie używana do obróbki łuku. W funkcji SIMPLE Do obróbki stosuje się tylko osiem typów ARC. Operator po prostu wybierz typ R i wprowadź parametry promienia łuku

MAX CUT i zewnętrzną trznię  $R_{ext}$  lub wewnętrzną trznię  $r_{int}$ . Ogólnie rzecz biorąc, łuk może być obrabiany przez płaskie rowki T w  Lub arc TOOL, różnica między różnymi płaszczyznami roboczymi, jak pokazano poniżej:

- 1, PROSTY proste przetwarzanie
- 2, TYP 1 - 8 Tryb ARC.
- 3, SEL\_XY(XZ, YZ) wybierz miejsce
- 4, RAD Promień łuku
5. Porozmawiaj z nim Średnica narzędzia
- 6 MAKSYMALNE CIĘCIE Krok podawania
- 7, RAD TL — łuk zewnętrzny i  
łuk wewnętrzny

(tylko dla miejsca xy)

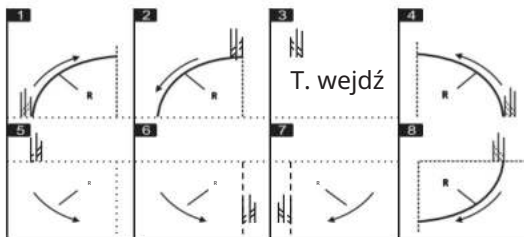

## ARC Processing

---

### Smooth ARC function :

Provides maximum flexibility in ARC machining, the ARC sector to be machined by the coordinates of ARC. Very flexible, ARC function can machine virtually all kinds of ARC, even the intersected ARC. Relatively a bit complicated to operate, operator need to calculate and enter the coordinates of ARC centre, start angle and end angle.

Basic parameter as follow:

1. SMOOTH	Mode of the Smooth ARC processing;
2. SEL_XY(YZ, XZ)	Select place;
3. CENTER	Refer to the position of an center.
4. RAD	Radius of the ARC
5. TL_DIA	Diameter of the TOOL
6. MAX_CUT	Feed step
7. ST_ANG	Starting angle
8. ED_ANG	Ending angle
9. RAD+TL	Outer arc.
RAD-TL	Inner arc.

### Example 1 for the Simple ARC Processing:

Parameters settings as follow:

SIMPLE	Simple mode
TYPE	3
SEL_XY	XY
RAD	80.000
TL_DIA	6.000
MAX_CUT	0.500
RAD+TL	1

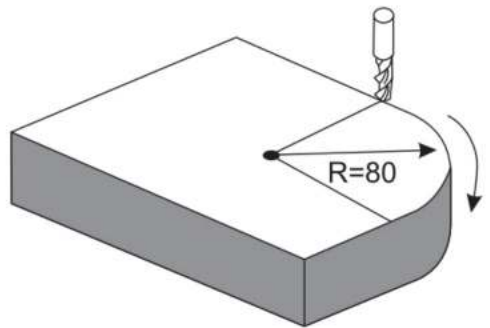

### Steps:

1. Select process mode

Press , then the message window display "SIMPLE" to the ARC Processing. Press  or  to select mode of the simple, The message window display "SIMPLE"

## ARC Processing



2. Input the type:

Press **ENT** until “TYPE” appears in the message window. X-window displays the formerly preset type. Press **3** in turn



3. Select place

Press **ENT** until “SEL\_XY” appears in the message window.

Press **▲** or **▼** to select place to display “SEL\_XY”;



4. Input radius:

Press **ENT** until “RAD” appears in the message window. X-window displays the formerly preset radius of ARC. Press **80** in turn to input the radius.;

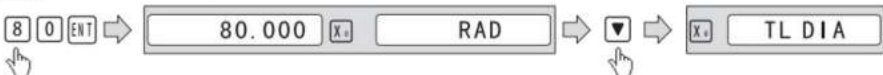

5. Input Diameter of the TOOL

Press **▲** or **▼** until “TL DIA” appears in the message window. X-window displays the formerly preset Diameter of the TOOL. Press **6** in turn to input the Diameter value;



6. Input Feed step (MAX\_CUT);

Press **▲** or **▼** until “MAX\_CUT” appears in the message window. X-window displays the formerly preset MAX\_CUT. Press **0.5** in turn to input the MAX\_CUT value;



## ARC Processing

## 7. Select outer arc or inner arc

Press or until “RAD-TL” appears in the message window. Press or to select place to display “RAD+TL” ;

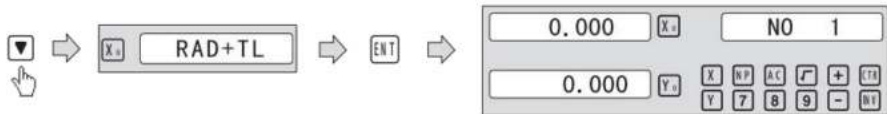

## 8. After inputting all parameters, press the key for machining.

The DRO will display the position of the first point. Retract the axes until the displays read 0.000, Machine the Arc point by point in accordance with the display. After finishing the position of the first point, press or to change position point.



Press to quit R function any time.

**Example 2 for the Simple ARC Processing:**

Parameters settings as follow:

SIMPLE	Simple mode
TYPE	3
SEL_XY	XZ .....
RAD	80.000 .....
TL_DIA	6.000 .....
MAX_CUT	0.500 .....

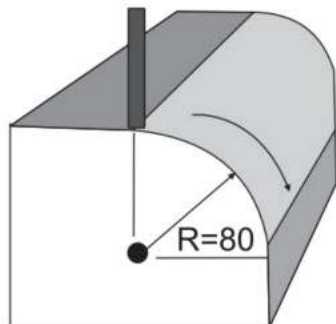

Steps:

1. Press , then the message window display “SIMPLE” to the ARC Processing. Press or to select mode of the simple, The message window display “SIMPLE”

## ARC Processing



2. Input the type:

Press **ENT** until “TYPE” appears in the message window. X-window displays the formerly preset type. Press **3** in turn



3. Select place

Press **ENT** until “SEL\_XZ” appears in the message window.

Press **▲** or **▼** to select place to display “SEL\_XZ” ;



4. Input radius:

Press **ENT** until “RAD” appears in the message window. X window displays the formerly preset the radius of ARC. Press **80** in turn to input the radius.;



5. Input Diameter of the TOOL

Press **▲** or **▼** until “TL DIA” appears in the message window. X window displays the formerly preset the Diameter of the TOOL. Press **6** in turn to input the Diameter value;



6. Input Feed step (MAX\_CUT);

Press **▲** or **▼** until “MAX\_CUT” appears in the message window. X window displays the formerly preset the MAX\_CUT. Press **0.5** in turn to input the MAX\_CUT value;



## ARC Processing

7. After inputting all parameters, press the key **ENT** for machining.

For 2-axis milling machine table, It is not installed with Z-axis, please press **▲** or **▼** to simulate position of Z-axis. Press **▲** simulate moving to the former process, and press **▼** simulate moving to the next process point.

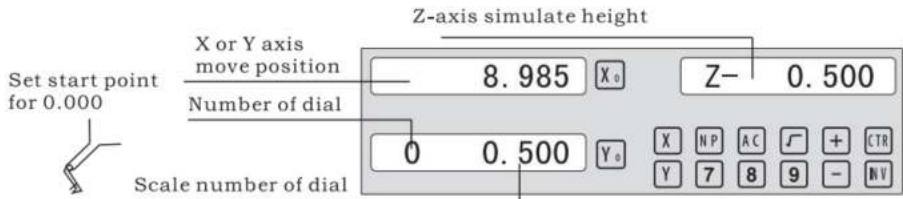

Z-axis simulate height = Number of dial x Z axis Dial + Scale number of dial

Press **▼** to quit R function any time.

### Example 3 for the Smooth ARC function:

Parameters settings as follow:

SMOOTH	Smooth mode
SEL_XY(YZ,XZ)	XY
CENTER	X=0,Y=0
RAD	80.000
TL_DIA	6.000
MAX_CUT	0.500
ST_ANG	0.000
ED_ANG	135.000
RAD+TL	1

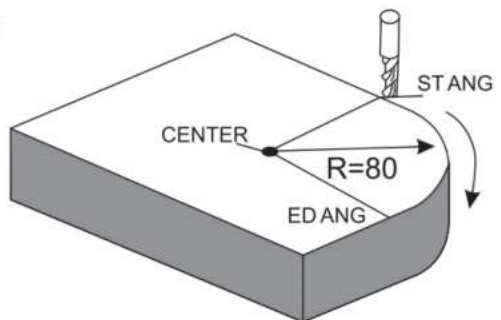

Steps:

1. Press **▼**, then the message window display "SIMPLE" to the ARC Processing. Press **▲** or **▼** to select mode of the simple, The

## ARC Processing

message window display “SMOOTH” ; For 3-axis milling machine table without this step. In second step. Then press **ENT** .



### 2. Select place

Message window display “SEL\_XY” which indicates the select is to place. Press **▲** or **▼** to select place to display “SEL\_XY” ;

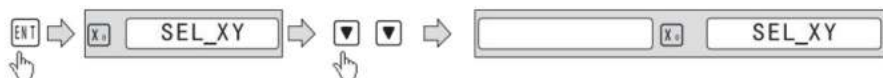

### 3. Input center position.

Press **ENT** , then the message window display “CENTER” . X and Y window displays the formerly preset center position. Input X = 0, Y = 0 as follow.

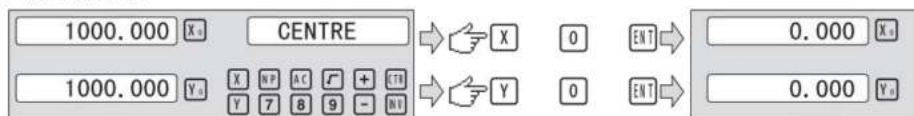

### 4. Input radius:

Press **ENT** until “RAD” appears in the message window. X window despalys the formerly preset the radius of ARC. Press **8** **0** in turn to input the radius.;





### 5. Input Diameter of the TOOL



Press **▲** or **▼** until “TL DIA” appears in the message window. X window despalys the formerly preset the Diameter of the TOOL. Press **6** in turn to input the Diameter value;



## 6. Krok podawania wejściowego (MAX\_CUT);

naciskać  Lub  aż do momentu, gdy aplikacja UMAX CUT pojawi się w wiadomości

okno. X Window de spa lys poprzednio ustawione MAX\_CUT. naciśnij

   po kolei, aby wprowadzić wartość MAX CUT;

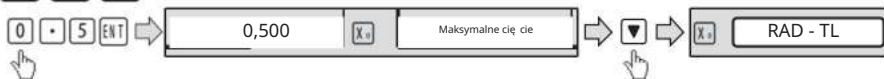

## 7. Wprowadź kąt początkowy ·

naciskać  dopóki w oknie wiadomości nie pojawi się napis „USTANG”.

okno spa lys poprzednio ustawiony kąt początkowy · Nastę pnie naciśnij

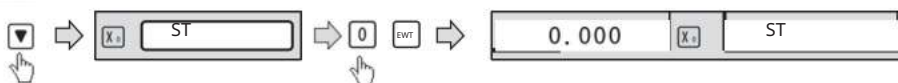

 po kolei, aby wprowadzić kąt początkowy-



## 8. Wprowadź kąt końcowy ·

naciskać  dopóki w oknie komunikatu nie pojawi się napis „UED ANG”.



okno ispa lys poprzednio ustawiony kąt końcowy. Nastę pnie naciśnij

  po kolei, aby wprowadzić kąt końcowy-



## 9. Wybierz łuk zewnę trzny lub łuk wewnę trzny

okno  Lub  aż w komunikacie pojawi się „RAD-TL”

prasowe.naciśnij  Lub  aby wybrać miejsce wyświetlania "RAD+TL";

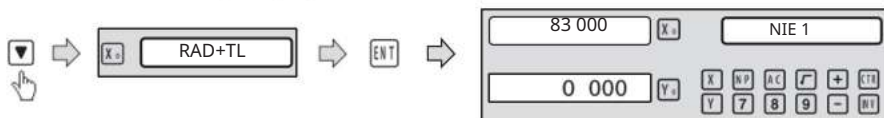
10. Po wprowadzeniu wszystkich parametrów, **machining.**

DRO wyświetli pozycję pierwszego punktu. Wycofaj

osie, aż wyświetlacz wskaże 0,000, Wytnij łuk punkt po punkcie zgodnie z wyświetlaczem. Po zakończeniu pozycji pierwszego

punkt, naciśnij  Lub  aby zmienić punkt położenia.

## ARC Processing

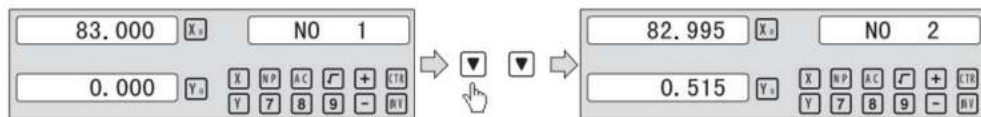

Press  to quit ARC function any time.

## 6.4 przetwarzanie skośne

Istnieją dwa sposoby obróbki miejsc skośnych:

A) na miejscu. b) na miejscu yz, lub Xz;

należy wprowadzić tylko następujące parametry:

Zawiera <u>X</u> y(xz,yz)	ustaw maszynę w miejscu xy,yz,0rxz ·
TO	Kąt nachylenia skośnego
TAM	Średnica narzędzia ·
ST <u>P</u> OT	Pozycja początkowa;
ED <u>C</u> AN	Zakończenie postawiania;

Przykład 1 dla ukośnego miejsca xy:

gdy płaszczyzna obróbki znajduje się na płaszczyźnie xy, jak pokazano na rysunku, kąt nachylenia przedmiotu obrabianego powinien być skalibrowany przed obróbką płaszczyzny skośnej. Dlatego, w tym momencie obróbka płaszczyzny skośnej pełni rolę kalibracji skośności.

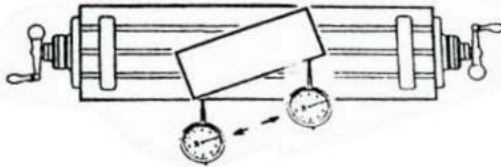

procedura kalibracji skosu

Najpierw umieść obrabiany przedmiot na stole roboczym pod wymaganym kątem skośnym.

- 1) Wprowadź funkcję płaszczyzny ukośnej.
- 2) Wybierz funkcję płaszczyzny XY.
- 3) Wprowadź kąt nachylenia.
- 4) Przesuwaj stół roboczy, aż narzędzie pomiarowe (np. czujnik zegarowy) zainstaluj diodę LED na frezarce, dotknie płaszczyzny kalibracji skośnej, ustaw ją na zero i przesun stół roboczy na dowolną odległość w kierunku osi x.
- 5) Przesun stół roboczy na odległość osi y, aż do wyświetlenia zmienia się na zero.



## Oblique Processing

---

6) Change the angle of the work piece to make the workpiece touch the measuring tool and adjust it to zero.

STEPS:



1. Select place

Press , then the message window display "INCL\_XY" to the Oblique Processing. Press  or  to select place to display "SEL\_XY";

Then press  to in next step;



2. Input the angle of obliquity

The message window display "ANG" , X window displays the formerly preset the angle of obliquity. Press   in turn to input the angle of obliquity .



3. Move the workpiece along the X-Axis until the measuring tool touches the workpiece adjust it to zero, and move the worktable for any distance along the X-Axis.



4. Press , display the value of Y-Axis. Move the workpiece along the Y-Axis, change the angle of workpiece to make the obliquity-calibrating plane touch the measuring tool until it turns to zero. Move the worktable until Y-Axis is displayed as zero.

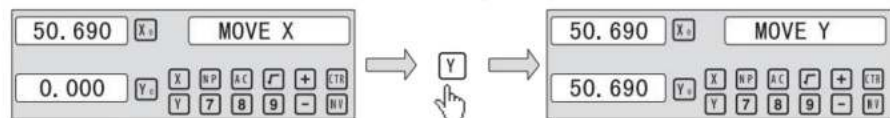

5. Press  to quit oblique function any time.

## Oblique Processing

### Example 2 for the oblique XZ or YZ place:

When the machining plane is on plane XZ or YZ, the function of TOOL inclination can instruct the operator to machine the oblique plane step by step.



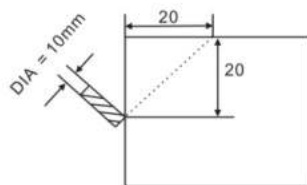
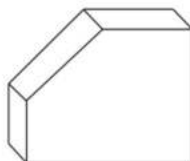

Procedures for using the function of cutter inclination:

When the machining plane is on plane XZ or YZ, first please calibrate the obliquity of the primary spindle nose and set the TOOL:

INCL_XY(XZ,YZ)	INCL_XZ
DIA	10.000
ST_POT	20.000
ED_POT	20.000





#### STEPS:

1. Press , then the message window display “INCL\_XY” to the oblique Processing. Press  or  to select place to display “SEL\_XZ; Then press  to in next step;



2. Input The TOOL Diameter

The message window display “DIA” , X window displays the formerly preset the angle of obliquity. Press   in turn to input the TOOL Diameter of obliquity . OK, then press  to in next step;



3. Input ST\_POT;

The message window display “ST\_POT” , X and Y window displays the formerly preset the stating position of obliquity. Input X= 0, Y = -20.000. OK, then press  to in next step;

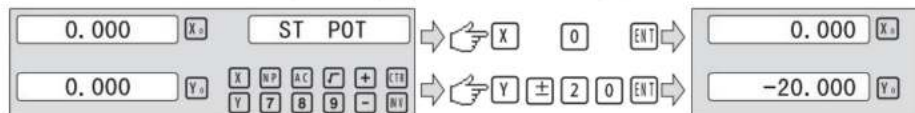



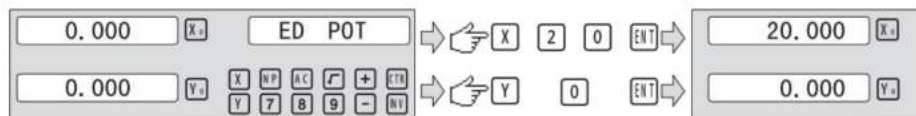

## Oblique Processing

### 4. Input ED\_POT;

The message window display “ED\_POT” , X and Y window displays the formerly preset the starting position of obliquity. Input X= 20.000, Y = 0.000 .



### 5. After input all parameter, press the key for machining.

For 2-axis milling machine table , It is not installed with Z-axis, please press  or  to simulate position of Z-axis. Press  simulate moving to the former process, and press  simulate moving to the next process point.

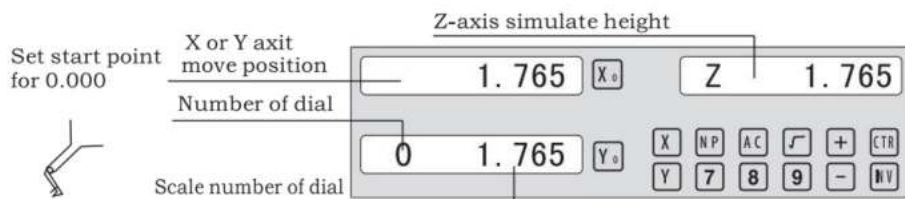

Z-axis simulate height = Number of dial x Z axis Dial + Scale number of dial

Press  to quit **oblique** function any time.

## Slope Processing



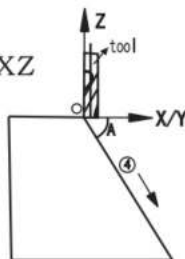

## 6.5 Slope Processing

This function can calculate the position of every processing point automatically in processing slope. Only the following parameters need to be inputted:

XZ, YZ	Set machine place YZ, or XZ
ANG	The inclination angle
Z_STEP	The slope length each time processing



**Example 1 for the Slope XZ place;**

Step 1. Select place

Press , then the message window display “XZ” to the slope Processing. Press  or  to select place to display “SEL\_XY; Then press  to in next step;





Step 2. Input the angle of slope

The message window display “ANG”, X window displays the formerly preset the angle of slope. Press   in turn.



Step 3. Input Z\_step;

The message window display “Z STEP”, X window displays the formerly preset the stating position of slope. Input    in turn.



Step 4: Finishing the ALL processing . Press  to quit slope function any time.

## Chambering Processing

### 6.6 Chambering Processing

1, FLAT\_XY: machine place; 2, DIA:diameter of TOOL; 3, CENTER: center of the chambering ; 4, SIZE: size of the chambering ;

Figure as follow:

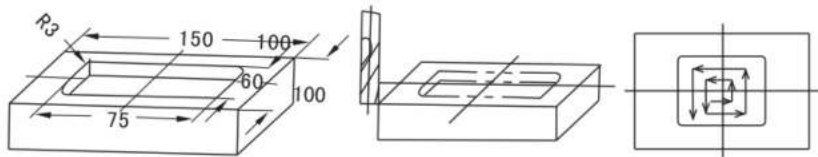

STEPS:

1. Press , then the message window display "FLAT\_XY" to the Chambering Processing.



2. Input DIA of the TOOL;





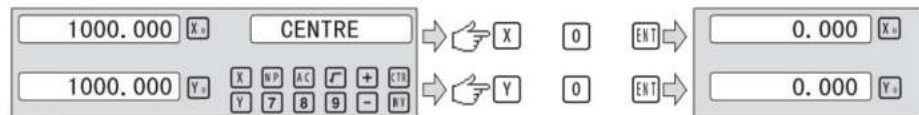

3. Input the center coordinate;

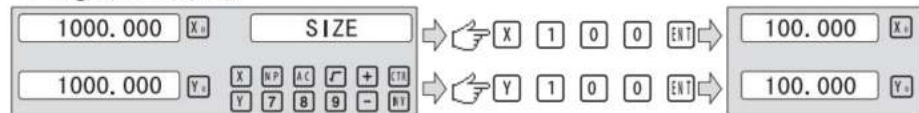

4. Input the size;



5. process Chambering;

Move the machine until the display of the axis is zero, ie, the position of the first point. Machine the first point . Display the next machining point by pressing  or  .On the completion of machining, the right window shows OVER. Press  or  , the system will goto the first position for the next workpiece. Press  to quit the Chambering Function.

## The Tool Diameter Compensation Function

### 6.7 The Tool Diameter Compensation Function

Without TOOL compensation, the operator has to move the TOOL for an additional distance of the diameter of the TOOL along each side when machining the four 150 and 100 sides of a workpiece to finish machining the whole brim. The digital readouts shall automatically compensate when the TOOL compensation function is enable.

Note: the TOOL compensation is made in the direction of X and Yaxis.

Procedures:

- 1). Enter the function of compensating the diameter of the TOOL.
- 2). Select one of the (four) preset machining modes.
- 3). Input the diameter of the TOOL.
- 4). Enter machining.

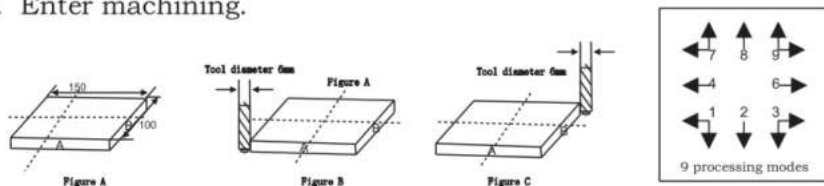

Step1: press  $\frac{D}{1}$  to enter the TOOL compensation Function. then the message window display “TYPE” .Press **9** .



Step 2: input the diameter of the TOOL; Press **1** **0** in turn..



Step 3: Press  $\nabla$  to the machining Mode.

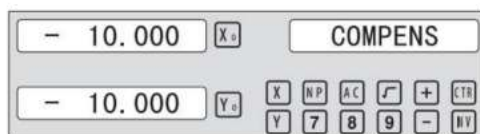

Machining of 2 side planes can be done by moving the TOOL until X-Axis is 150.000 and Y-Axis is 100.000.Press the Key  $\frac{D}{3}$  to quit the Function.

## The Tool Diameter Compensation Function

---

### 6.8 Digital Filter of the Grinding Machine

When machine a work-piece by grinder, the display values quickly due to the vibration of grinder. User can not see display value clearly. Grinder DRO provides display value filter function to disable the quake change of display value.

STEPS:

1. Enter display value filter function.

In normal display state, press **SFT** to simultaneously, enter display value filter function.

2. Exit display value filter function;

Press **SFT** , exit display value filter function;

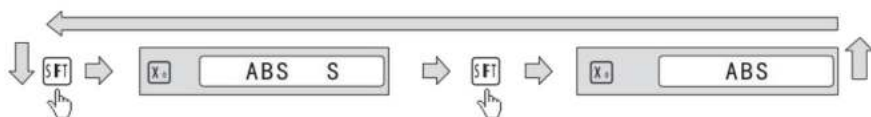

## 6.9 La Funkcja

6.9. 1 200 zestawów bibliotek narzędziowych

Do obróbki różnych części zawsze potrzebne jest inne NARZĘDZIE · Do wygodna obsługa, cyfrowe odczyty La mają funkcję

200 zestawów bibliotek narzędziowych ·

Uwaga: Tylko wtedy, gdy la jest wyposażona w blok ustawiania narzędzi, można używać 200 · zestawów bibliotek narzędzi.

1. ustaw punkt odniesienia TOOL. Po ustawieniu narzędzia, wyzeruj oś x i oś Z, ustaw zero współrzędnych bezwzględnych ·

2. Na podstawie rozmiaru TOOL I i datu TOOL określ położenie NARZĘDZIA względem zera współrzędnej bezwzględnej i narzędzia odniesienia · AS Rysunek 6-1. Względny rozmiar NARZĘDZIA 2 to AS podążający za osią x 25-30=- 5

, Oś Z 20-10=10 ·

3. Zapisz numer narzędzia i jego rozmiar w cyfrowym czytniku ·

4. Numer NARZĘDZIA można wprowadzić losowo, odczyty cyfrowe wyświetli położenie narzędzia do współrzędnej absolutnej zera · Przesuń la aż oś X i oś Z nie wyświetlą zera · 5. Biblioteki narzędzi mogą zapisać 200 zestawów danych narzędzi.

6. Biblioteki TOOL muszą być używane w stanie otwarcia. 200 zestawów rooi Libs można otworzyć poprzez ciągłe naciśnięcie



dziesięć razy

aż do momentu, gdy w prawym okienku zacznie migać napis TL - OTWARTE i pojawi się znak „21” po lewej stronie prawego okna informacyjnego. Znak wskazuje

operator CAN konfiguracja lub zmiana 200 zestawów TOOL Lib s. w sposób ciągły

naciśnięcie klawisza  dziesięć razy spowoduje, że biblioteki narzędziowe 200sets będą powoduje zamknięcie i miganie prawego okna TL - CLOSE i Mark

zniknie · gdy zniknie Mark „21” , 200 zestawów bibliotek TOOL może nie podlegać rewizji

Operacje na danych TOOL i wywołanie TOOL są pokazane następująco: · krok 1: W stanie ABS wprowadź dane 200 zestawów bibliotek TOOL.

otwieranie 200 zestawów bibliotek TOOL poprzez ciągłe naciśnięcie klawisza

 dziesięć razy A. Znak „” pojawi się w lewym oknie prawego okna informacyjnego.

## Lathe Function

krok 2: naciśnij **TOOL** aby UZYSKAĆ dostęp p do stanu wprowadzania. Wprowadź dane roci 1:

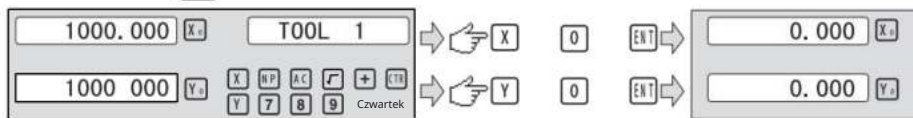

krok 3: Wprowadź dane narzędzia dla TOOL 2:

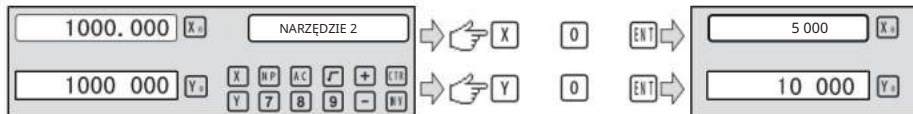

krok 4: naciśnij **TOOL**, aby kontynuować wprowadzanie danych następnego narzędzia. POPRZEC Naciśnięcie numer i klucz, operator może bezpośrednio wprowadzić specjalny kod tooldata. naciśnij **TOOL** dotyka

Po skonfigurowaniu bibliotek TOOL należy używać ich zgodnie z

Po wykonaniu poniższych czynności najpierw zamontuj drugie narzędzie.

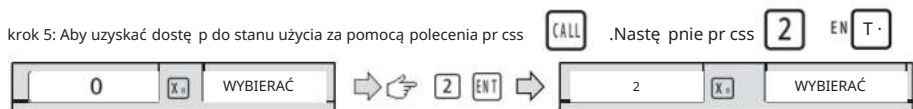

krok G: naciśnij **▲** lub **▼** wybierz rolkę bazową. Następnie naciśnij **1** **IT**



krok 7: naciśnij **CALL** aby wyjść z funkcji;

Notatka:

gdy używane jest narzędzie bazowe, oś CAN nie może zostać wyzerowana w stanie ABS  
gdy inne są używane, oś CAN może być zerowana tylko w stanie INC.

### 6.9.2 Funkcja zwężania

Do toczenia przedmiotu obrabianego ze stożkiem, stożek przedmiotu obrabianego może być mierzonym w przetwarzaniu;

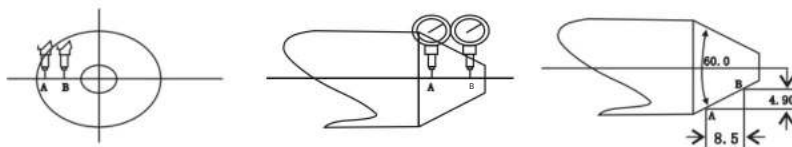

## Lathe Function

### Operations :

Rysunek AS, powierzchnia styku A przedmiotu obrabianego z odczytami dźwigni i resetuje wskazania dźwigni do zera ·

krok 1: naciśnij, a następnie wyświetli okno komunikatu „UMEASU”  
przetwarzanie papieru · Przesuń dźwignię odczytu na powierzchnię B, aż odczyty dźwigni punkt AS następują;



krok 2: naciśnij  $\frac{1}{2}$  aby obliczyć.

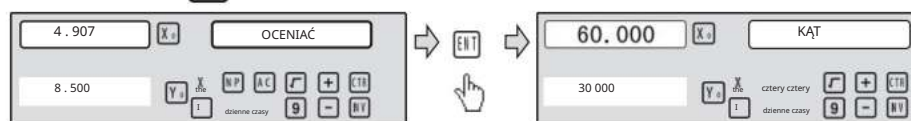

krok 3: naciśnij  $\frac{1}{2}$  aby wyjść z funkcji;

### 6. 9. 3 Funkcja badawczo-rozwojowa

Do tokarek 2-osiowych i 3-osiowych naciśnij  $\frac{1}{2}$ , Tryb wyświetlania osi ofx jest przełączana pomię dzy promieniem i średnicą. gdy os x dla wyświetlanie średnicy, okna  $\frac{1}{2}$  pojawi się po lewej stronie prawej informacyjnego znaku A, ale gdy os X służy do wyświetlania miernika ia, znak „” znika · tylko os x pełni funkcję średnicy/promienia transformation.

### 6. 9. 4 Funkcja Y + Z (dotyczy tylko: 3 osi La the)

Dla 3 osi La, licznika osi y i licznika osi z

Można dodać do wyświetlanego na osi Z poprzez naciśnięcie cie klawisza , następnie naciśnij klawisz CAn aby anulować funkcję y + Z ·

6.10 EDM (specjalna funkcja dostosowywania, jeśli potrzebujesz kupić, proszę skontaktuj się ze sprzedawcą w celu dostosowania)

1 Opis: Funkcja ta jest wykorzystywana do specjalnej obróbki

Obróbka elektroerozyjna (EDM) . gdy ustawiona wartość docelowa EDM

Oś Z jest równa wartości bieżącej, odczyt cyfrowy wyprowadzi

przełącz sygnał sterujący EDM, aby zatrzymać obróbkę głę bokoą.

Ustawienie kierunku osi Z na wyświetlaczu cyfrowym pokazano na rys. 1

Im wię ksza głę bokość, tym wię ksza wartość współrzę dnych osi Z

wyświetla · od rozpoczę cia obróbki głę bokość bę dzie stopniowo się zwię kszać i osi Z.

Zgodnie z ustawionym kierunkiem osi Z, kierunek obróbki jest

dzieli się na obróbkę pozytywną i negatywną · gdy elektroda

opada, a obróbka odbywa się od góry do dołu, cyfrowo

wartość odczytu wzrośnie, co nazywa się obróbką dodatnią (dodatnią).

Ustawienie tego kierunku jest ustawieniem normalnym.

gdy elektroda ASCEnduje się i wykonywana jest obróbka

od dołu do góry, wartość odczytu cyfrowego bę dzie się zmniejszać ·

kierunek obróbki jest kierunkiem ujemnym (ujemnym), który jest również nazywany obróbką negatywna (przedstawiona na rys. 1)

Cyfrowy odczyt posiada również inne funkcje , taki JAK negatywny

fire proof-height. Funkcja ujemnej wysokości ognioodpornej jest rodzajem

inteligentna pozycja śledź sprawdzaj urządzenie ochronne bezpieczeństwa. W procesie obróbki, powierzchnia elektrody wytworzy wę giel

zjawisko akumulacji. Z powodu długiego czasu lub obróbki dobowej

bez dbania o to, podczas generowania akumulacji wę gla i

nikt nie wykonuje czyszczenia, elektroda bę dzie powoli wzrastać wzdłuż

kierunek ujemny · gdy elektroda przekroczy poziom cieczy,

czę sto się zapalają i powodują straty. Ta funkcja jest ustawiona tylko do celu

w tym problemie. podczas ustawiania ujemnej wysokości ognioodpornej i

zwię kszone wysokość elektrody przekracza wysokość mię dzy nią a

głę bokość powierzchni obrabianej (tj. ujemna wysokość ognioodporna), cyfrowa

wyświetlacz odczytu bę dzie migał w celu sprawdzenia poprawności działania; w tym samym czasie wyjście

sygnał automatycznie wyłączy EDM, aby wyeliminować ryzyko pożaru ·

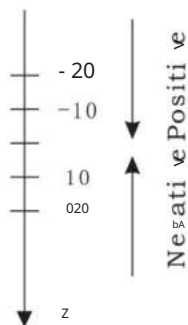

Rysunek 1

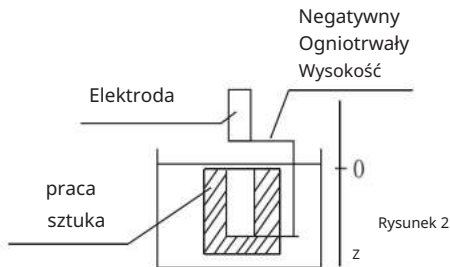

Rysunek 2

## 2. Procedura:

zobacz poniższy przykład szczegółowej obróbki

- 1) Przed obróbką należy najpierw ustawić każdy parametr GŁĘBOKOŚCI (głębokość obróbki); ERRHIGH (ujemna wysokość ognioodporna), obróbka kierunku (DODATNI/UJEMNY); tryb wyjścia (AUTO/STOP) i Tryb wyjścia przełącznika EDM · 2)

Przesuń elektrodę osi głównej osi Z, aby zetknęła się z odniesieniem do przedmiotu obrabianego · wyczyść oś A do zera lub ustaw wartość ·

- 3) Wprowadź obróbkę EDM za pomocą klawisza PR CSS  ·

4) Oś X wyświetli wartość docelową głębokości obróbki. Oś Y wyświetli wartość wyświetlaną, ma być głębokością. (Wartość na osi Y to wartość, na której głębokość obrabianego przedmiotu została obrabiona) Oś Z będzie wyświetlała wartość w czasie rzeczywistym dotyczącą własnego położenia. (Wartość na osi Z to wartość położenia głównej elektrody osiowej osi z.)

5) Rozpocznij obróbkę, wartość wyświetlana na osi Z stopniowo zbliży się do wartości docelowej, wyświetlana na osi Y wartość jest również stopniowo bliska wartości docelowej. Jeśli w tym momencie elektroda jest wielokrotnie przesuwana w górę i w dół, wartość wyświetlana na osi Z będzie się zmieniać, ale wartość wyświetlana na osi Y wartość nie ulegnie zmianie, co zawsze będzie wyświetlać głębokość obróbki **value**.

6) gdy wyświetlana wartość osi Z jest równa ustawionej wartości docelowej, przełącznik osiągnie swoją pozycję i zostanie wyłączony, EDM zatrzyma obróbkę, W zależności od ustawień operatora istnieją dwa rodzaje trybów wyjścia:

## a) Automatic Mode:

it will automatically exit from EDM machining status and recover to the original state before machining;

## b) Stop Mode:

It will always stay at the machining interface after finishing machining, and you should press **EDM** to exit and back to the original state.

**Operation steps:**

**The DEPTH (machining Depth), ERRHIGH (Negative fireproof height), exit Mode, EDM Relay Output Mode and machining direction should be set.**

**STEPS:**

1. Press **EDM** to enter the EDM Function. Press **▲** to input parameters; Press **▼** to enter EDM machining state.

2. Input DEPTH ( machining depth). Press the key **▲** to set the next parameter.



3. input ERRHIGH ( Negative Fireproof Height ) (undefine) .Press the key **▲** to set the next parameter.



4. Set machining direction(Positive or Negative). Press **1** to select Positive direction. Press **0** to select Negative direction. Press the key **▲** to set the next parameter.



## EDM

5. Set exit Mode (AUTO Mode or STOP Mode) Press **0** to select AUTO Mode; Press **1** to select STOP Mode ; Press the key **▲** to set the next parameter.

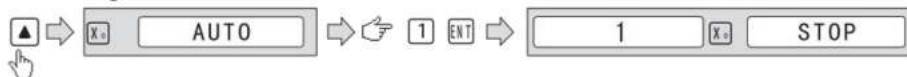

6. Set the Output Mode (Mode 0 or Mode 1); ( undefine ). Press **0** to select Mode 0; Press **1** to select Mode 1.

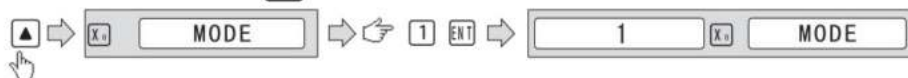

7. Continuously press **▼** to return EDM for machining. press **EDM** to quit the function;

### Example 1: positive direction machining ;

Machining is shown as the model chamber as follows

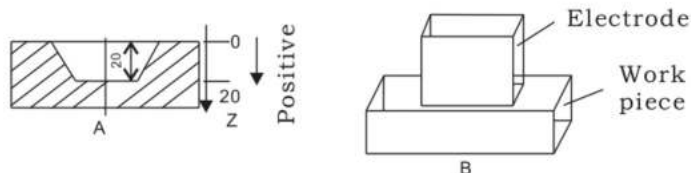

#### STEPS:

1、 Touch one side of the workpiece with the TOOL, then press **Z0** , zero the Z axis.



2、 Press **EDM** , Setting DEPTH for 20.000; press **▼** to EDM for machining;



3、 Starting machining.

## EDM

Machining depth target value	<input type="text" value="20.000"/>	<input type="button" value="X0"/>	<input type="button" value="EDM RUN"/>
Value has been to be depth	<input type="text" value="0.000"/>	<input type="button" value="Y0"/>	
Self-position real time value	<input type="text" value="0.000"/>	<input type="button" value="Z0"/>	

**Example 2: Negative direction machining**

Machining is shown as the model chamber as follows

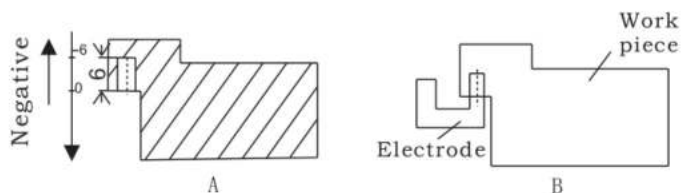

- 1、Touch one side of the workpiece with the TOOL, then press  , zero the Z axis.

<input type="text" value="1000.000"/>	<input type="button" value="Z0"/>	<input type="button" value="↔"/>	<input type="button" value="Z0"/>	<input type="button" value="↔"/>	<input type="text" value="0.000"/>	<input type="button" value="Z0"/>
---------------------------------------	-----------------------------------	----------------------------------	-----------------------------------	----------------------------------	------------------------------------	-----------------------------------

- 2、Press  , Setting DEPTH for -20.000; press  to EDM for machining;

<input type="button" value="EDM"/>	<input type="button" value="→"/>	<input type="button" value="X0"/>	<input type="text" value="DEPTH"/>	<input type="button" value="↔"/>	<input type="button" value="±"/>	<input type="text" value="20"/>	<input type="button" value="ENT"/>	<input type="text" value="-20.000"/>	<input type="button" value="X0"/>	<input type="text" value="DEPTH"/>
------------------------------------	----------------------------------	-----------------------------------	------------------------------------	----------------------------------	----------------------------------	---------------------------------	------------------------------------	--------------------------------------	-----------------------------------	------------------------------------

- 3、Starting machining.

Machining depth target value	<input type="text" value="20.000"/>	<input type="button" value="X0"/>	<input type="button" value="EDM RUN"/>
Value has been to be depth	<input type="text" value="0.000"/>	<input type="button" value="Y0"/>	
Self-position real time value	<input type="text" value="0.000"/>	<input type="button" value="Z0"/>	

**Example 3: PCD Function for EDM**



PCD Function can access the EDM Function . The operator enters PCD Function to input parameters for PCD and enter PCD machining state. At every position for machining, press the key  to access the EDM Function .

podczas wchodzenia do funkcji EDM operator może wprowadzić parametry dla EDM.

Procedura operacji wygląda następująco:

1) Ustaw parametry PCD (ustawienie jest takie samo jak ustawienie wspólne) (PKD)

Po wprowadzeniu wszystkich parametrów i przejściu do stanu obróbki PCD wyświetlona zostanie pozycja pierwszego dołka.

2) naciśnij  aby wprowadzić parametr funkcji EDM (metoda ustawień to ten sam przycisk, co ustawienie wspólne parametru EDM); po wprowadzeniu wszystkich parametrów, naciśnij ciągle, gdy obróbka  aby wejść w stan obróbki EDM. aby jest zakończona, naciśnij, aby wprowadzić  wyjść z funkcji EDM i stan obróbki PCD.

3) W stanie obróbki PCD naciśnij  dla pozycji następnego dołka, Przesuń maszynę do wartości wyświetlanej 0, następnie przciśnij  uzyskać dostęp p

Ponowne uruchomienie

funkcji EDM. 4) Powtórz krok 2 i krok 3 dla następujących punktów obróbki.

## Calculator

### 7 kalkulator

Kalkulator nie tylko umożliwia wykonywanie normalnych obliczeń matematycznych takie jak +, -,  $\times$ , /, zapewnia również trygonometrię do obliczeń metrycznych, takich jak AS GRZECH, Łuk SIN, SAŁATA, Łuk COS, DĘBNIK, Łuk TAN SQRT itd.

Obsługa jest taka sama jak w przypadku kalkulatorów komercyjnych i jest prosta. Wejdź i wyjdź z funkcji kalkulatora

w normalnym trybie wyświetlania: naciśnij R, aby wejść w funkcję kalkulatora.

w trybie wyświetlania kalkulatora: naciśnij R, aby wyjść z funkcji kalkulatora.

Wynik transferu kalkulatora dla wybranego zx wynosi.

Po zakończeniu obliczeń, jeżeli tryb wyświetlania kalkulatora jest ustawiony na tryb 1, użytkownik może:

naciśnij  $X_0$  aby przenieść obliczony wynik na oś tox; następnie pnie x okno, a wyświetli się ta wartość;

naciskać  $Y_0$  aby przenieść obliczony wynik na oś zabawki; następnie pnie okno wyświetli tę wartość;

naciśnij  $Z_0$  aby przenieść obliczony wynik na oś z; następnie pnie z okno, a wyświetli się ta wartość;

Przesyłanie bieżącej wartości wyświetlanej w oknie do kalkulatora.

jeśli kalkulator wyświetla Tryb ustawiony na tryb 1, użytkownik może:

naciskać  $X$  przeniesienie wartości wyświetlanej w oknie X do kalkulatora;

naciskać  $Y$  aby przesłać wartość wyświetlaną w oknie Y w celu obliczenia r;

naciskać  $Z$  aby przesłać wartość wyświetlaną w oknie z do kalkulatora;

## Appendix

## 8 Appendix

## 1. Troubleshooting:

The following are the preliminary solvents for troubleshooting.

If there is still trouble, Please contact out company or agents for help.

Troubles	Possible reasons	Solvents
No display	<ol style="list-style-type: none"> <li>1. Power isn't connected</li> <li>2. Power switch is off.</li> <li>3. The range of power voltage is not right.</li> <li>4. The inner power of Linear Scale is short.</li> </ol>	<ol style="list-style-type: none"> <li>1. Check power wire and connect the power</li> <li>2. Turn on the power switch.</li> <li>3. The range of voltage is in 80--260V</li> <li>4. Unplug the connector of linear scale</li> </ol>
One axis is not counting	<ol style="list-style-type: none"> <li>1. Replace the linear scale of the other axis.</li> <li>2. DRO is in special function</li> </ol>	<ol style="list-style-type: none"> <li>1. If count is normal, the linear scale has trouble; If abnormal, the DRO readouts has trouble.</li> <li>2. Quit the special function.</li> </ol>
Linear scale is not counting	<ol style="list-style-type: none"> <li>1. Reading head is bad for using range exceeds.</li> <li>2. Aluminum chips is in reading head of linear scale.</li> <li>3. The span between the reading head and metal part of linear scale is large.</li> <li>4. The metal parts of linear scale is damage.</li> </ol>	<ol style="list-style-type: none"> <li>1. Repair the linear scale</li> <li>2. Repair the linear scale</li> <li>3. Repair the linear scale</li> <li>4. Repair the linear scale</li> </ol>
Counting is error	<ol style="list-style-type: none"> <li>1. Shell is poor grounding.</li> <li>2. Low precision of machine.</li> <li>3. Speed of machine is too rapid.</li> <li>4. Precision of linear scale is low.</li> <li>5. The resolution of DRO readouts and the linear scale is not match.</li> <li>6. The unit (mm/inch) is not match.</li> <li>7. Setting the linear compensating is not arrest.</li> <li>8. Reading head of the linear scale is damaged.</li> </ol>	<ol style="list-style-type: none"> <li>1. Shell is good grounding.</li> <li>2. Repair the machine.</li> <li>3. Reduce the speed of machine.</li> <li>4. Mount the linear scale again.</li> <li>5. Set the resolution of the DRO again.</li> <li>6. Cover the unit of display mm/inch.</li> <li>7. Reset the linear compensation.</li> <li>8. Repair the linear scale.</li> </ol>
The counting of the linear scale is not accurate	<ol style="list-style-type: none"> <li>1. The mounting of linear scale does not demand the requirement, and the prcision is not adequate.</li> <li>2. The screw is loosen.</li> <li>3. Precision of machine is low.</li> <li>4. The resolution of digital readouts and the linear scale is not match.</li> </ol>	<ol style="list-style-type: none"> <li>1. Mount the linear scale again and level it.</li> <li>2. Lock all fixing screws.</li> <li>3. Repair the machine.</li> <li>4. Reset the resolution of digital readouts.</li> </ol>
Sometimes the linear scale is not counting	<ol style="list-style-type: none"> <li>1. The small car and steel ball is separated.</li> <li>2. The glass of reading head is wearied.</li> <li>3. The glass of reading head of the linear scale has dirt.</li> <li>4. The elasticity of the steel wire is not adequate.</li> </ol>	<ol style="list-style-type: none"> <li>1. Repair the linear scale.</li> <li>2. Repair the linear scale.</li> <li>3. Repair the linear scale.</li> <li>4. Repair the linear scale.</li> </ol>

## Appendix

### 2. Specifications of Digital Readout.

- 1) Supply Voltage range: AC 85 V ~ 230 V; 50 ~ 60 Hz
- 2) Power consumption: 15VA
- 3) Operating temperature: 0°C-- 50°C
- 4) Storage temperature: - 30°C-- 70°C
- 5) Relative humidity: < 90 % ( 25 )
- 6) Max Coordinate number: 3
- 7) Readout allowable input signal: TTL square wave
- 8) Allowable input signal frequency: < 5 M Hz
- 9) Max resolution of digital display length: 0.01 um
- 10) Max resolution of digital display angle: 0.0001 / PULSE

### 3. Instructions

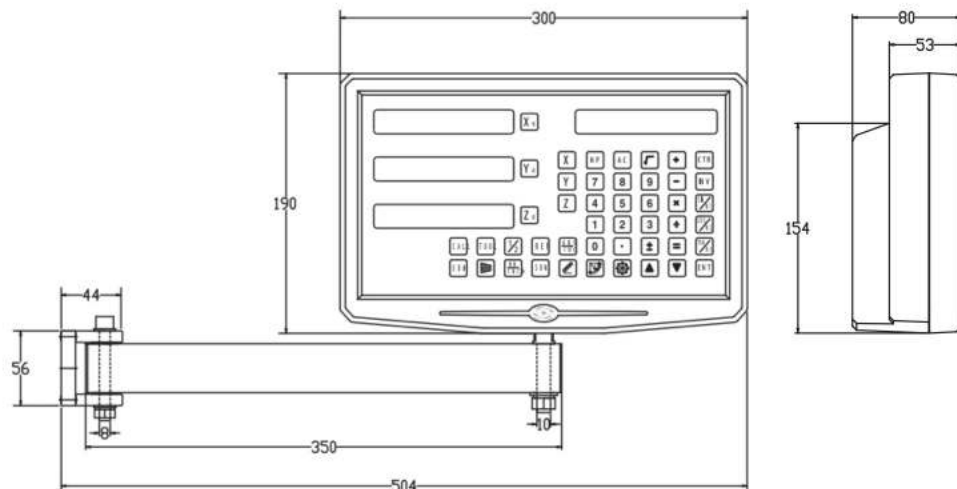

## 4. Examples of character output at the data interface

## 1、 X,Y,Z Axis

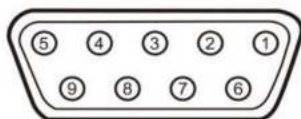

Pin	TTL (Standard)
1	
2	0V
3	
4	
5	
6	A+
7	5V
8	B+
9	R+

Pin	TTL (Standard)
1	5V
2	0V
3	A+
4	B+
5	R+
6	
7	
8	
9	

For your convenience,  
If you buy a digital readout,

The wiring definition of your linear scale must be the same as the 2 definitions in the above diagram to be universal!



## TTL signal Output:

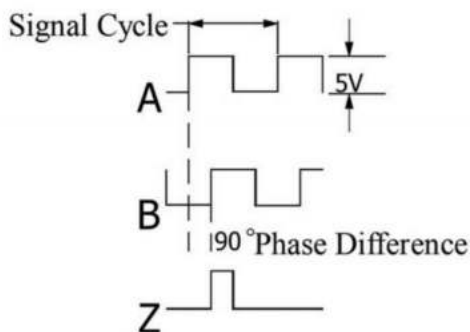

## EIA-422-A signal Output:

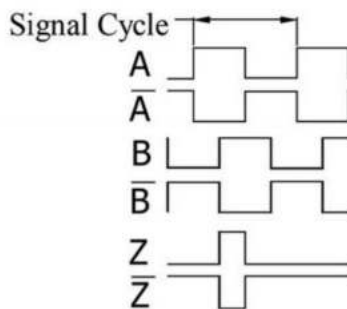

## 1. TECHNICAL PARAMETER

1.1 SCALING DISTANCE: 0.02 MM (50LINES /MM)

1.2 RESOLUTION: 5 $\mu$ M、1 $\mu$ M、0.5 $\mu$ M1.3 PRECISION:  $\pm 3\mu$ M、 $\pm 5\mu$ M、 $\pm 15\mu$ M/M (20 $\pm$ 0.1°C)

1.4 MEASURING RANGE: 30~3000MM

1.5 MOVING SPEED: HIGH-SPEED ENCODER 120 M/MIN (TO BE CUSTOMIZED)

ORDINARY ENCODER 60M/MIN

1.6 POWER SUPPLY: +5V $\pm$ 5%、80MA

1.7 CABLE LENGTH: STANDARD 3M (SPECIAL LENGTH AVAILABLE ACCORDING TO THE USER'S NEEDS)☒

1.8 WORKING TEMPERATURE: 0~45°C

1.9 PIN DESCRIPTION:

1) APPLICABLE TO: 9 PIN SOCKET EIA-422-A SIGNAL OUTPUT.

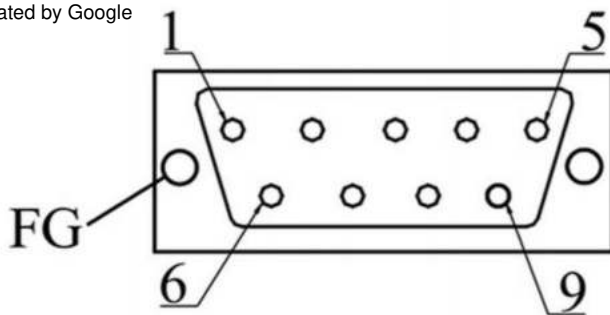

1) Applicable to: 9 pin socket EIA-422-A signal Output.

Pin Position	1	2	3	4	5	6	7	8	9
Signal	$\bar{A}$	$OV$	$\bar{B}$	Empty	$\bar{Z}$	$A$	+5V	$B$	$Z$
Color	Green Black	Black	Orange black	FG	White black	Green	Red	White	Orange

FG: Shield connected to metal casing.

1) Applicable to: 9 pin socket TTL signal Output.

Pin Position	1	2	3	4	5	6	7	8	9
Signal		$OV$		Empty		$A$	+5V	$B$	$Z$
Color		Black		FG		Green	Red	Orange	White

FG: Shield connected to metal casing.

# Skala liniowa

## Rysunki instalacyjne

# Metoda instalacji:

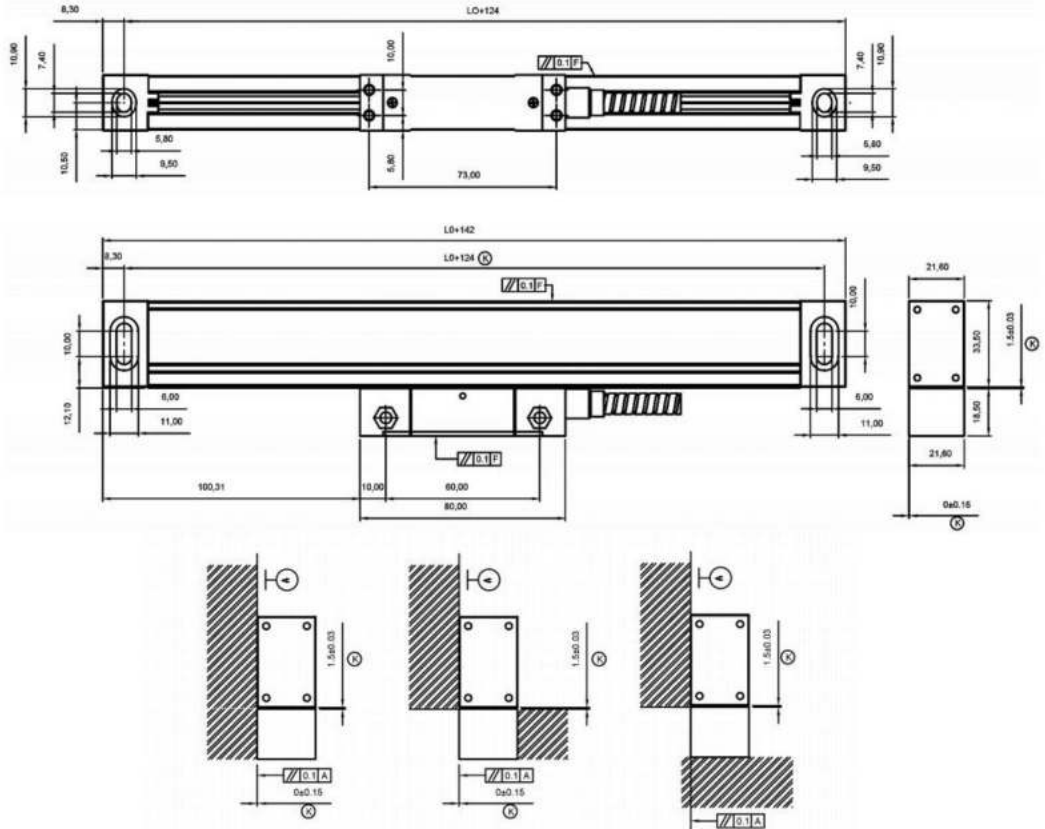

Rozmiar standardowy: (Jednostka: mm)

Model	TO	L1	L2	Model	L0	L1	L2
YE-50	50	174	190	lat-550 550		674	690
YE-100	100	224	240	lat-600	600	724	740
YE-150	150	274	290	YE-650 650		774	790
YE-200 200		324	340	lat-700 700		824	840
YE-250 250		374	390	YE-750	750	874	890
YE-300 300		424	440	YE-800	800	924	940
YE-350 350		474	490	YE-850 850		974	990
YE-400 400		524	540	YE-900	900	1024	1040
YE-450 450		574	590	YE-950 950		1074	1090
YE-500 500		624	640	lat-1000 1000		1124	1140

L0: Efektywna długość pomiarowa enkodera liniowego; L1: Długość enkodera liniowego otwory montażowe; L2: całkowita długość enkodera liniowego

## Konserwacja:

1. Efektywny przesuw enkodera liniowego powinien być dłuższy niż maksymalny przesuwu obrabiarki. Jeśli długość jest niewystarczająca, należy wymienić enkoder liniowy na wię kszy lub dodać blok ograniczający na maszynach. Pozycja końcowa głowicy odczytującej od końca korpusu enkodera liniowego powinna być nie mniejsza niż 10 mm odstę pu, (patrz poniższy schemat).

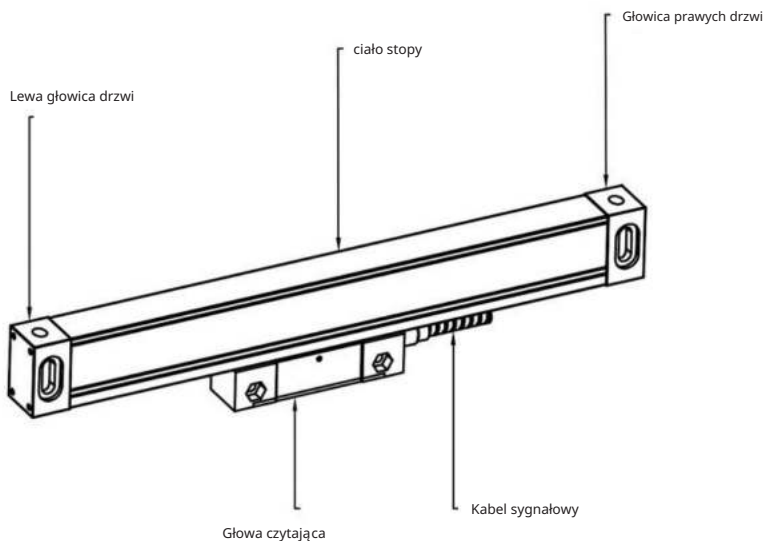

2. W przypadku powierzchni nieobrobionych, z tyłu enkodera liniowego należy umieścić podkładkę lub zastosować samodzielnie wykonaną podkładkę montażową, aby zapewnić stabilność i niezawodność połączenia pomię dzy linałem kratowym a powierzchnią mo
3. Podczas kalibracji równoległości enkodera liniowego za pomocą czujnika zegarowego lub podobnego przyrządu, kąt głowicy bocznej musi mieścić się w granicach  $\pm 30$  stopni. Im mniejszy kąt, tym lepiej.

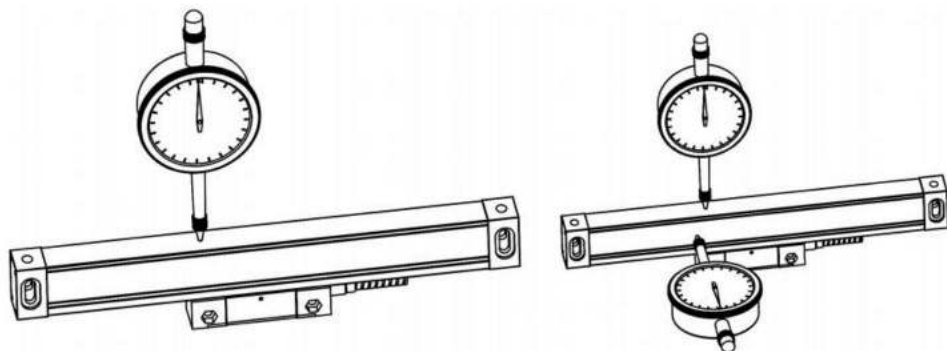

4. Pozycja montażu enkodera liniowego musi być taka, aby nie był narażony na bezpośrednie działanie żelaza, opiłki, olej, woda i kurz (jak pokazano na poniższym rysunku). Długość instalacji długość płyty L powinna być możliwie najkrótsza w możliwych okolicznościach, a należy wziąć pod uwagę sytuację siłową powierzchni montażowej.

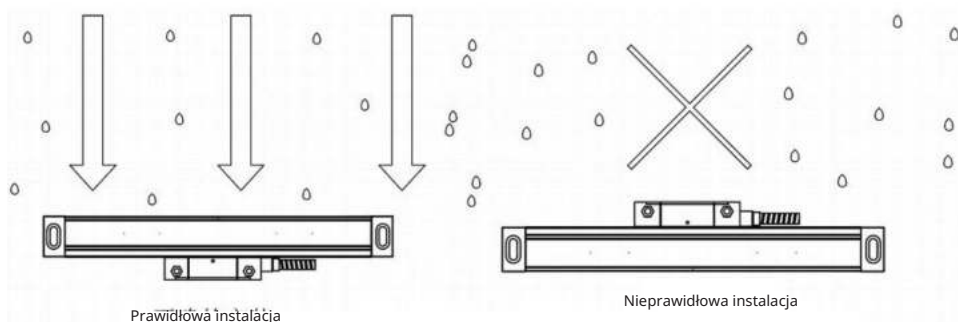

5. Między osłoną przeciwpylową a linijką musi być odstęp  $p$  co najmniej 0,5 mm. Korpus i unikaj kontaktu pokrywy przeciwpylowej z korpusem linijki podczas przesuwając głowicę czytającą (jak poniżej).
6. Głębokość gwintu śruby montażowej musi wynosić co najmniej 6 zębów głębokości blokowania; siła wiązki części, taka jak podtrzymywanie cyfrowej półki licznika wyświetlacza płyty stałej, musi mieć 8 zębów głębokości blokowania; seria YE skali, głębokość gwintu głębokość głębokości blokowania. Takie jak podtrzymywanie wyświetlacza cyfrowego półka miernika stała płyta, musi mieć głębokość blokowania więcej niż 8 zębów; skala serii YE ze śrubami M4 zamontowano powierzchnię montażową, gwintowano po odgratowaniu powierzchni, usunięciu ciu farby i plam. (Poniższy rysunek)

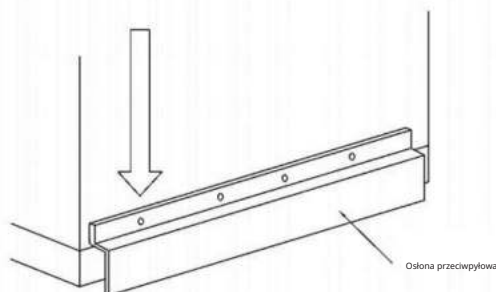
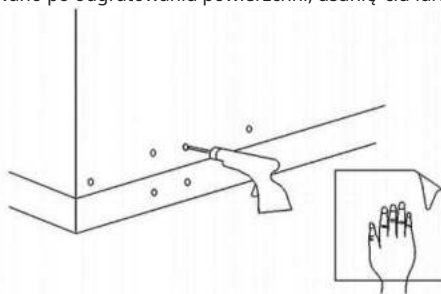

7. Mocowanie linii sygnałowej musi uwzględnić wszystkie istotne odległości ruchome.

Miejsce mocowania należy umieścić możliwie jak najbardziej w samym środku skoku, a nadmiar przewodu sygnałowego zamocować opaską zaciskową.

8. Regulacja wysokości skali musi być długością środka skali, aby wziąć dwa boki punktu symetrii. Dostosuj punkt odniesienia, dowolną skalę niezależnie od kierunku poziomu szkody lub kierunku wysokości, zakres regulacji: dla korpusu skali, do głowicy od korpusu skali w odległości nie więcej niż 20 mm od każdego końca ma pierwszeństwo. Dla głowicy czytającej, między dwiema czworokątnymi powierzchniami odniesienia (następny rysunek)

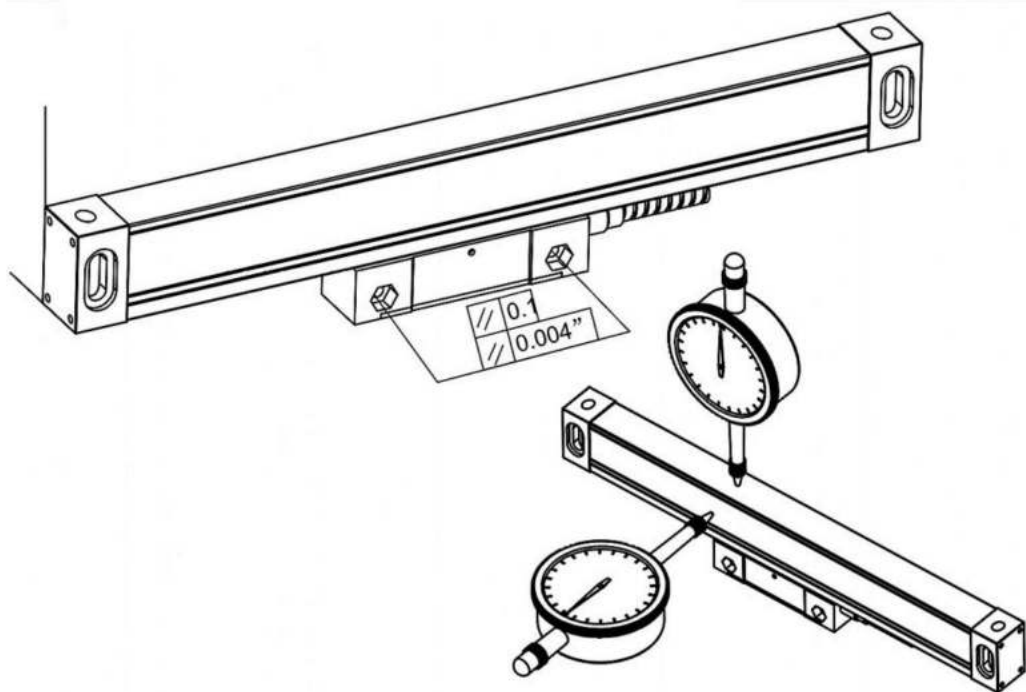

9. Promień gięcia przewodu sygnałowego skali jest większy niż 60 mm.

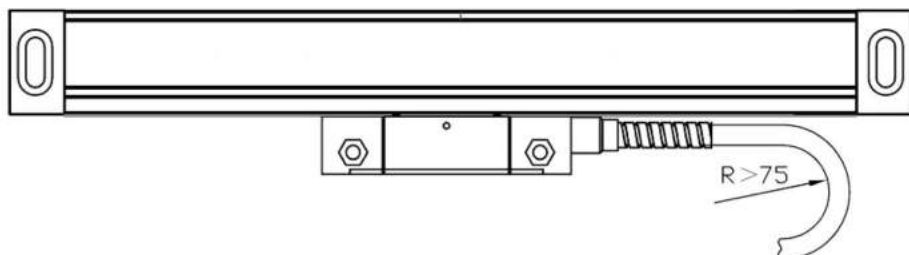

(1) Standardowa powierzchnia podstawy instalacji (rysunek 4.8abc trzy metody instalacji)

1. Powierzchnia montażowa korpusu linijki jest równoległa do powierzchni montażowej głowicy odczytującej, a równoległość między powierzchniami montażowymi wynosi  $<0,1$  mm
2. Powierzchnia montażowa korpusu linijki jest prostopadła do powierzchni montażowej powierzchni głowicy odczytującej, a prostopadłość między powierzchniami instalacyjnymi wynosi  $<0,1$  mm

2) Normy montażu korpusu linijki (rysunek 4.9, rysunek 4.10)

1. Kierunek wysokości względem równoległości prowadnicy maszyny  $<0,1$  mm, maksymalnie nie więcej niż  $0,15$  mm. Pod względem punktu symetrii im mniejszy tym lepiej.

3) Standard instalacji głowicy odczytującej

1. Po zainstalowaniu odstęp między głowicą odczytującą a kierunkiem wysokości korpusu linijki wynosi  $0,8-1,6$  mm; następnie należy wyjąć blok podkładek (rysunek 4.11).

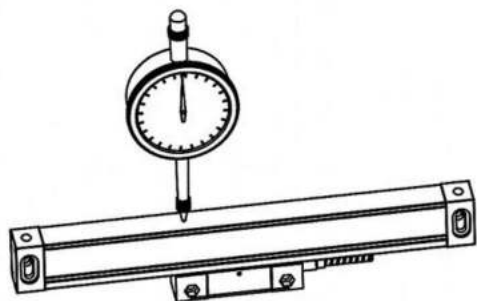

4.9

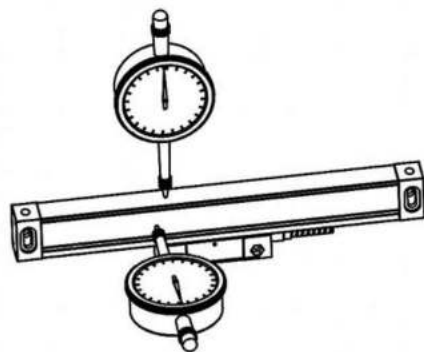

4.10

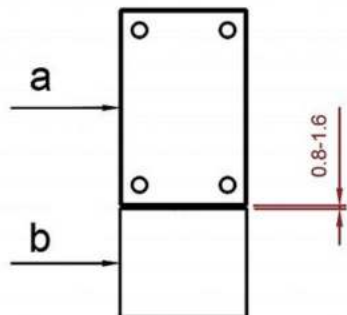

2. Głowica czytająca stroną A i korpus linijki stroną B.  
Niewspółosiowość w kierunku poziomym.  
 $0,25 \pm 0,15$  mm

3. Równoległość głowicy czytającej względem obrabiarki  $<0,10$  mm, maksimum nie może przekroczyć  $0,30$  mm

## Parametr:

<b>Model</b>	SNS-3V-YE102024	SNS-3V-YE161838
<b>Rated voltage:</b>	AC85-230V 50Hz/60Hz	
<b>Resolution</b>	5 $\mu$ m	
<b>Number of axes</b>	3	
<b>Range</b>	10 inches 20 inches 24 inches	16 inches 18 inches 38 inches

Akcesoria standardowe:

<b>Accessories for digital display meters:</b>	<b>Accessories for grating ruler:</b>
<ol style="list-style-type: none"> <li>1. Support rod * 1</li> <li>2. Knife holder plate * 1</li> <li>3. Transparent watch case * 1</li> <li>4. Power cord * 1</li> <li>5. Watch holder * 1</li> <li>6. Butterfly piece * 2</li> <li>7. M8 * 70 screw * 1</li> <li>8. M10 * 55 screw * 1</li> <li>9. Nut M10 * 1</li> <li>10. Nut M8 * 1</li> <li>11. Nut M5 * 1</li> <li>12. Internal hexagonal screw M5 * 20 * 2</li> <li>13. Internal hexagonal screw M5 * 25 * 1</li> <li>14. M4 * hex socket screw * 4</li> <li>15. M5 * 10 machine meter screws * 2</li> <li>16. Washer <math>\phi</math> 10 * 1</li> <li>17. Washer <math>\phi</math> 8 * 1</li> <li>18. Washer <math>\phi</math> 5 * 1</li> <li>19. Rubber washer 20 * 10 * 1 * 1</li> <li>20. Rubber washer 20 * 10 * 0.5 * 1</li> <li>21. Spring washer <math>\phi</math> 10 * 1</li> <li>22. Spring washer <math>\phi</math> 8 * 1</li> <li>23. Spring washer <math>\phi</math> 5 * 1</li> </ol>	<ol style="list-style-type: none"> <li>1. Ruler cover * 3</li> <li>2. L mounting plate * 4</li> <li>3. Plug * 6</li> <li>4. Screw pack * 3 bags</li> </ol> <p>Each bag contains:</p> <p>Internal hexagonal screw M4 * 30 * 4;            Internal hexagonal screw M4 * 12 * 2;            Internal hexagonal screw M4 * 8 * 4;            U-shaped gasket T=0.2mm * 2;            Washer <math>\phi</math> 6 * 2;            Washer <math>\phi</math> 5 * 2;            Washer <math>\phi</math> 4 * 6;            Line card * 2</p>

To urządzenie jest zgodne z częścią 15 przepisów FCC. Jego działanie podlega następującym dwóm warunkom: (1) To urządzenie nie może powodować szkodliwych zakłóceń i (2) to urządzenie musi akceptować wszelkie odbierane zakłócenia, w tym zakłócenia, które mogą powodować niepożądane działanie.

Producent: Shanghaimuxinmuyeyouxiangongsi

Adres: Shuangchenglu 803nong11hao1602A-1609shi, baoshanqu, szanghaj  
200000 CN.

Importowane do AUS: SIHAO PTY LTD, 1 ROKEVA STREETEASTWOOD NSW  
2122 Australia

Importowane do USA: Sanven Technology Ltd., Suite 250, 9166 Anaheim Place,  
Rancho Cucamonga, CA 91730



E-CrossStu GmbH

Mainzer Landstr.69, 60329 Frankfurt nad Menem.



YH CONSULTING LIMITED.

C/O YH Consulting Limited Biuro 147, Centurion House,  
London Road, Staines-upon-Thames, Surrey, TW18 4AX

**VEVOR**®  
TOUGH TOOLS, HALF PRICE

Wsparcie techniczne i certyfikat e-gwarancji  
[www.vevor.com/support](http://www.vevor.com/support)

# VEVOR<sup>®</sup>

## TOUGH TOOLS, HALF PRICE

Technische ondersteuning en E-garantie certificaat

[www.vevor.com/support](http://www.vevor.com/support)

### DRO DISPLAY GEBRUIKERSHANDLEIDING

MODEL: SNS-3V-YE102024 IS NS-3V-YE161838

Wij blijven ons inzetten om u gereedschappen te leveren tegen concurrerende prijzen. "red de helft" , "Halve prijs" of andere soortgelijke uitdrukkingen die wij gebruiken, vertegenwoordigen slechts een schatting van de besparingen die u kunt behalen door bepaalde gereedschappen bij ons te kopen in vergelijking met de belangrijkste topmerken en betekent niet noodzakelijkerwijs dat alle categorieën gereedschappen die wij aanbieden, worden gedekt. U

Wij herinneren u eraan om bij het plaatsen van een bestelling bij ons zorgvuldig te controleren of u: in feite de helft besparen vergeleken met de grote topmerken.

**VEVOR**<sup>®</sup>  
TOUGH TOOLS, HALF PRICE

DRO-SCHERM

MODEL: SNS-3V-YE102024 SNS-3V-YE161838



HULP NODIG? NEEM CONTACT MET ONS OP!

Heeft u vragen over het product? Heeft u technische ondersteuning nodig? Neem dan gerust contact met ons op.

Neem contact met ons op:

Technische ondersteuning en E-garantie certificaat  
[www.vevor.com/support](http://www.vevor.com/support)

Dit is de originele instructie, lees alle instructies in de handleiding zorgvuldig voor gebruik. VEVOR behoudt zich een duidelijke interpretatie van onze gebruikershandleiding voor. Het uiterlijk van het product is onderworpen aan de product dat u hebt ontvangen. Vergeef ons dat we u niet meer op de hoogte stellen als er technologische of software-updates voor ons product zijn.

Beste gebruikers:

Bedankt voor uw aankoop van de multifunctionele digitale uitlezingen .

Digitale uitlezingen worden in een breed scala aan toepassingen gebruikt. Deze omvatten: gereedschapswerktuigen , in invoerassen, meet- en inspectieapparatuur, EDM en meetstations voor verdeelapparaten, instelgereedschappen , productiecontrole. Om te voldoen aan de eisen van deze

Bij veel toepassingen kunnen veel encoders op de digitale uitlezingen worden aangesloten.

Lees alle instructies in de handleiding zorgvuldig door voordat u het product gebruikt en

volg ze strikt op · bewaar de handleiding voor toekomstige referenties .

Veiligheidswaarschuwing:

⚠ Om elektrische schokken of brand, vocht of direct gespoten vloeistof te voorkomen koelvloeistof moet worden vermeden. In geval van rook of bijzondere ruik je de geur van de digitale uitlezing, trek dan de stekker uit het stopcontact onmiddellijk, anders kan er brand of een elektrische schok ontstaan. Probeer in zo'n geval niet om het te repareren, maar neem contact op met het bedrijf of **distributors.**

⚠ Digitale uitlezing is een nauwkeurig meetinstrument dat wordt gebruikt met een optische Lineaire schaal· wanneer het in gebruik is, als de verbinding tussen de Lineaire schaal en de digitale uitlezing zijn kapot of beschadigd extern kunnen er onjuiste meetwaarden ontstaan · Daarom, De gebruiker moet voorzichtig zijn.

⚠ Probeer de digitale uitlezing niet te repareren of te wijzigen, anders kan er een storing optreden. fout of letsel kan optreden. In geval van een abnormale toestand, Neem contact op met het bedrijf of de distributeur.

⚠ Als de optische lineaire weegschaal die met de digitale uitlezing wordt gebruikt, beschadigd is, mag u geen lineaire weegschaal van een ander merk gebruiken. · Omdat de prestaties, specificaties en aansluitingen van de producten van verschillende merken en niet worden aangesloten zonder de instructie van een gespecialiseerde technicus personeel, anders ontstaan er problemen met de digitale uitlezing.

⚠ **With the continuous updating of products, if there are changes or**

Bij wijzigingen in de voorbeeldparameters hebben de willekeurige bestanden voorrang en heeft het bedrijf het uiteindelijke interpretatierecht zonder voorafgaande kennisgeving.

## Contents

---

1.	Illustration of Panel and keyboard .....	4
2.	Caption of the keyboard .....	5
3.	Parameters settings .....	7
3.1	Parameters setup routine entrance .....	7
3.2	Parameters Settings Description .....	7
3.2.1	Setting the Resolution .....	7
3.2.2	Setting Positive Direction for Counter .....	8
3.2.3	Toggle Between R/D Display Mode .....	8
3.2.4	Setting Z axis Dial .....	8
3.2.5	Setting the Rotary Radius of the Workpiece.....	9
3.2.6	Setting the Angle Display Mode .....	9
3.2.7	Setting the Baudrate of RS_232(optional) .....	9
3.2.8	Setting the Absolute Zeroing enable or disable .....	10
3.2.9	Setting the Absolute form the Special Function .....	10
3.2.10	Setting the Calculator display Mode.....	10
3.2.11	display brightness setting .....	10
3.2.12	The linear scale counting frequency setting .....	11
3.2.13	Setting QUIT .....	11
3.2.14	Setting the type of the DRO. ....	11
3.2.15	Signal Interface Type .....	11
3.2.16	Restore Factory Settings: .....	12
3.2.17	Shrinkage Ratio enable or disable.....	12
3.2.18	Setting Compensation Type .....	12
3.2.19	Inch display, set the number of digits after the decimal point...	13
3.2.20	Setting EDM(optional) .....	13
3.2.21	Setting Linearity Compensation. ....	13
3.2.22	Setting the Shrinkage Ratio .....	13
4.	General Operations .....	14
4.1	Zeroing.....	14
4.2	Preset Data to Designated Axis .....	14
4.3	Toggle Display Unit between inch and mm .....	14
4.4	Absolute/Incremental/200 groups SDM .....	15
4.5	1/2 Function .....	15
4.6	Clear All SDM Datum.....	16

## Contents

---

4.7 Sleeping Mode .....	16
4.8 Power Interruption Memory .....	16
4.9 Search the Absolute Reference Point of Scale .....	17
4.10 Non Linear Error Compensation .....	20
5、200 Groups SDM coordinate .....	21
5.1 Zeroing at the Current Point.....	21
5.2 Preset datum of SDM coordinate .....	22
6、Special Function.....	24
6.1 Circumference Holes Processing .....	25
6.2 Linear Holes Processing .....	28
6.3 ARC Processing .....	30
6.4 Oblique Processing .....	39
6.5 Slope Processng.....	43
6.6 Chamber Processing.....	44
6.7 The Tool Diameter Compensation Function .....	45
6.8 Digital Filter of the Grinding Machine .....	46
6.9 Lathe Function .....	47
6.9.1 200 sets TOOL Libs .....	47
6.9.2 Taper Function .....	48
6.9.3 R/D Function .....	49
6.9.4 Y + Z Function ( only applicable to : 3 axes Lathe).....	49
6.10 EDM.....	50
7、Calculator.....	56
8、Appendix .....	57

## Illustration of Panel and keyboard

## THREE AXIS PANEL

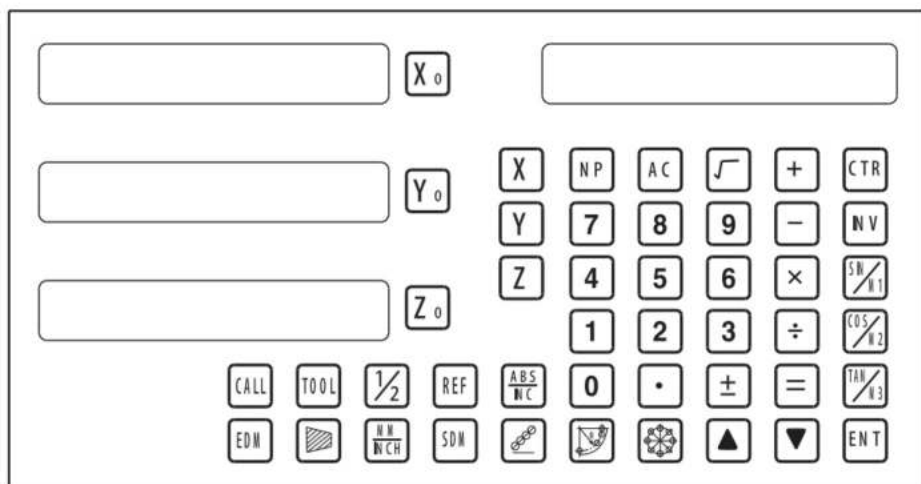



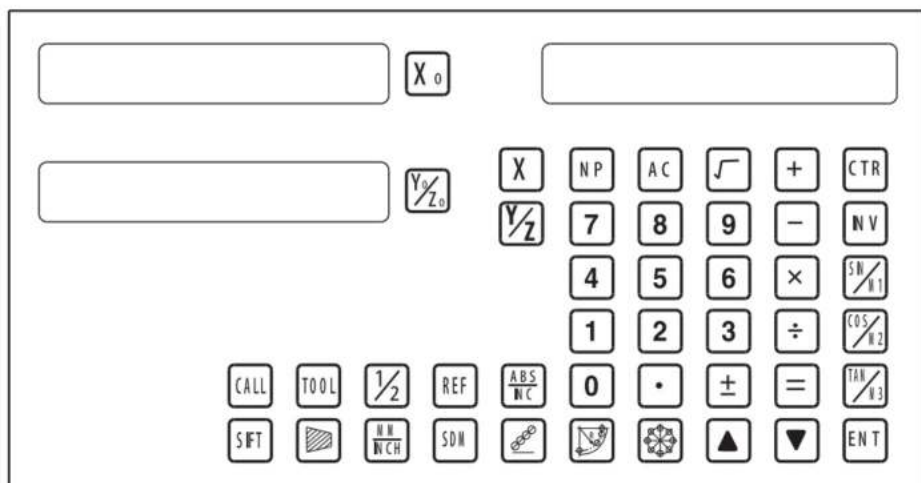









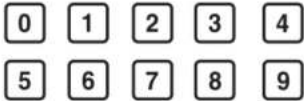



## TWO AXIS PANEL















## Caption of the keyboard

## Keyboard Description

	Keys for axis selection
	Zero select axis
	Enter +/- sign
	Enter decimal point
	Entry keys for numbers
	Operation key (in Calculation function key)
	Enter or quit calculating state
	Cancel incorrect operation
	Calculate inverse trigonometric
	Square root
	Confirm operation
	Toggles between inch and millimeter units.
	Press when ready to identify a reference mark.
	Function keys for 200 sub datum
	ARC cutting function
	holes displayed equally on a circle
	holes displayed equally on a line

## Caption of the keyboard

	Calculate trigonometric or Slope Processing function key
	Calculate trigonometric or rectangular inner chamber processing function key
	Calculate trigonometric or the tool diameter compensation function key
	Toggle between ABS/INC coordinate
	Stroll up or down to select
	Taper measured function key
	Tool library call key
	Opens the tool table.( lathe)
	EDM function key
	Filter display function key
	Half a display value of an axis
	Non Linear Error Compensation function keys

## Parameters settings

## 3. Parameters settings

## 3.1 Parameters setup routine entrance.

Press  $\square \bullet$  to enter initial system and self-check after DRO powers on in 1 second, then Parameters settings display in the Parameters window. press  $\blacktriangle$   $\blacktriangledown$  to select the item you want to change.

If you want to quit initial setting, press  $\blacktriangle$   $\blacktriangledown$  until "QUIT" appears in message window and press  $\square \text{ENT}$ . You can also press  $\square \bullet$  to quit initial setting.

## 3.2 Parameters Settings Description

## 3.2.1 Setting the Resolution

Press  $\blacktriangle$   $\blacktriangledown$  until "RESOLUTE" appears in message window;

When selecting the LINEAR encode, the resolution will be set as follow:

There are 19 types of resolution:

0.01um;0.02um;0.05um;0.10um;0.20um;0.25um;0.50um;1.00um;2.00um;2.50um;5.00um;10.00um;20.00um;25.00um;50.00um;100.00um;200.00um;250.00um;500.00um.

Press  $\square X_0$  to change the resolution for X axis; Press  $\square Y_0$  to change the resolution for Y axis; Press  $\square Z_0$  to change the resolution for Z axis;

Set the resolution 5.00um to 1.00um for X axis:

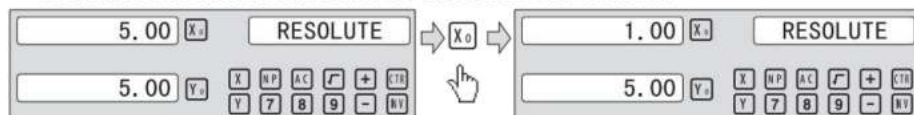

When selecting the rotary encode, the resolution will be set as follow:

Input the rotary encode parameter value .

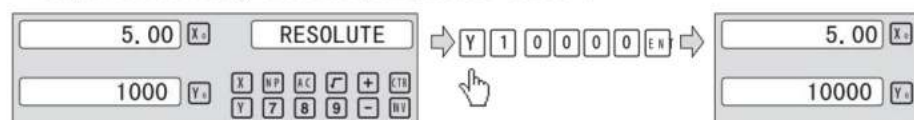

## Parameters settings

## 3.2.2 Setting Positive Direction for Counter

Press  $\blacktriangle$   $\blacktriangledown$  until “DIRECTE” appears in message window.

Direction ‘0’ means the display value will increase when scale moves from right to left and decrease when scale moves from left to right. Direction ‘1’ means the display value will increase when scale moves from left to right and decrease when scale moves from right to left.

Press  $X_0$  to change the Direction for X axis; Press  $Y_0$  to change the Direction for Y axis; Press  $Z_0$  to change the Direction for Z axis; as follow:

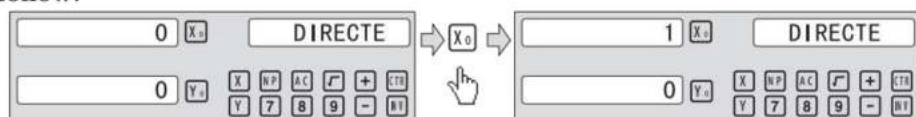

## 3.2.3 Toggle Between R/D Display Mode

Press  $\blacktriangle$   $\blacktriangledown$  until “R OR D” appears in message window. X window, Y window, Z window displays ‘0’ or ‘1’ separately.

‘0’ is mode R, which means the display value equals the actual measurement. ‘1’ is mode D where the display value equals the double actual measurement. Press  $X_0$  to change the R/D for X axis; Press  $Y_0$  to change the R/D for Y axis; Press  $Z_0$  to change the R/D for Z axis; as follow:

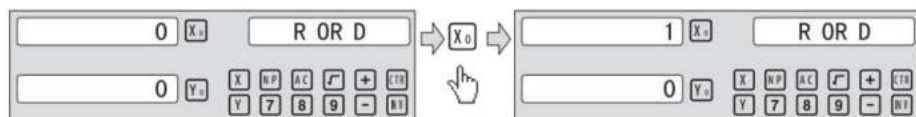

## 3.2.4 Setting Z axis Dial

Press  $\blacktriangle$   $\blacktriangledown$  until “Z DIAL” appears in message window.

Z axis dial should be set if Z axis is emulated for 2 axis milling and only install linear scale for X,Y axis. Z axis dial means the distance the Z axis travels when screw runs a revolution.

## Parameters settings

Set the Z axis Dial 2.5mm as follow ;



### 3.2.5 Setting the Rotary Radius of the Workpiece

Press **▲** **▼** until “RDIUS” appears in message window.

The Rotary radius type is used perimeter to measure angle.

Input the Rotary Radius parameter value 2000mm as follow:

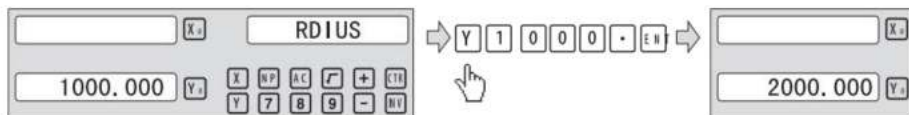

### 3.2.6 Setting the Angle Display Mode

Press **▲** **▼** until “ANG DISP” appears in message window.

Press **X<sub>0</sub>** to change the angle display mode for X axis; Press **Y<sub>0</sub>** to change the angle display mode for Y axis; Press **Z<sub>0</sub>** to change the angle display mode for Z axis; Example for X axis:

“0.0000” means the angle mode is Circulating DD;

“0000.0000” means the angle mode is Incremental DD;

“0.00.00” means the angle mode is Circulating DMS;

“0000.00.00” means the angle mode is Incremental DMS;

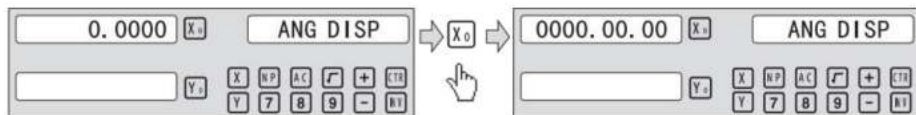

### 3.2.7 Setting the Baudrate of RS\_232 (Special customization function, if you need to buy, please contact the dealer to customize)



Press **▲** **▼** until “BAUDRATE” appears in message window.

Set the Baudrate 115200 as follow ;





## parameterinstellingen

## 3. 2. 8 Instellen van de absolute nulstelling in- of uitschakelen



pers   totdat "ABS\_ZERO" in het berichtenvenster verschijnt.  
de betekent dat de ABS-nulstelling en de vooraf ingestelde gegevens worden uitgevoerd  
inschakelen in de normale weergavestatus -

'1' betekent dat de ABS-nulstelling en de vooraf ingestelde gegevens worden uitgevoerd  
uitschakelen in de normale weergavestatus -

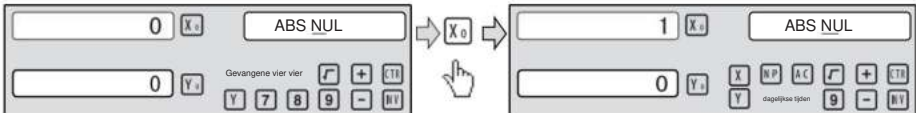
druk om  om de absolute nulstellingsmodus voor de x-as te wijzigen, drukt u op  
 de absolute nulstellingsmodus voor de Y-as te wijzigen, drukt op  naar  
verander de absolute nulmodus voor de Z-as; Voorbeeld voor de x-as -



## 3. 2. 9 het instellen van de Absolute vorm van de speciale Functie



pers   totdat "ABS\_ASST" in het berichtenvenster verschijnt.  
'0' betekent dat alleen de speciale functiepositiewaarde wordt weergegeven in de  
speciale Functiebewerking.

'1' betekent speciale functie positiewaarde + ABS Positiewaarde is  
weergegeven in de speciale Functiebewerking.

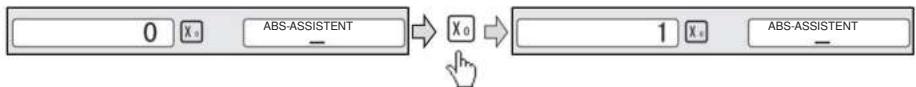
pers  om de absolute modus voor de speciale functie te wijzigen, zal  
als volgt worden ingesteld:



## 3. 2.10 instellen van de Calculator Weergavemodus

pers   totdat "UCCTR\_MODE" verschijnt in bericht W · **indow**  
de de weergavewaarde van de rekenmachine bij de x wind **nde** **disply**;

'1' betekent de weergavewaarde van de rekenmachine in het berichtenvenster op het **disply**;

pers  om de weergavemodus van de rekenmachine te wijzigen, wordt AS ingesteld **follow**;

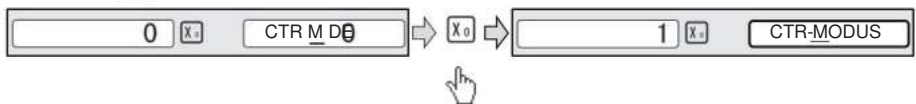

## 3.2.11 Instelling helderheid beeldscherm

Instelling helderheid LED-scherm, de fabrieksinstelling is alleen  
"3", hoe hoger de parameter, hoe helderder de helderheid. Druk op "x0" om  
is het niet aan te raden om de standaardwaarde zelf in te stellen.

## Parameters settings

## 3.2.12 The linear scale counting frequency setting

The factory default setting is only "12", the higher the parameter, the lower the counting frequency, press "X0" to set, it is not recommended that you set the default value yourself.

## 3.2.13 Setting QUIT: Digital display table parameters quit button.

## 3.2.14 Setting the type of the DRO.

The type of the DRO will be display on the right window. then press the key **ENT** to select the correct type. the following system item will be set:

"MILL-3" means the DRO type is 3-axis milling machine table;

"MILL-2" means the DRO type is 2-axis milling machine table;

"LATHE-2" means the DRO type is 2-axis lathe table;

"LATHE-3" means the DRO type is 3-axis lathe table;

"GRIND" means the DRO type is Grind table;

"EDM" means the DRO type is EDM table; (Special customization function, if you need to buy, please contact the dealer to customize)

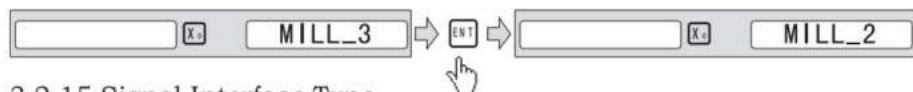

## 3.2.15 Signal Interface Type

Message window displays "SEL AXIS" which indicates the step is to Sensor input signal mode. Press **X0** to change the signal mode for X axis; Press **Y0** to change the signal mode for Y axis; Press **Z0** to change the signal mode for Z axis; Example for X axis:

Press **X0** to scroll through the Rotary encode type, the Linear encode type, the Rotary rdius type.

X window displays the Signal type.

"LInER" means the Signal type is linear encode type ;

"EnCoDE " means the Signal type is Rotary encode type;

"RdIUS" means the Signal type is Rotary rdius type ;

Example: currently in the linear encode type, to toggle to the Rotary encode type;

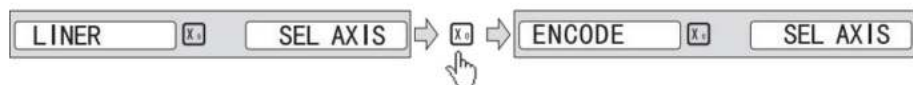

## Parameters settings

## 3.2.16 Restore Factory Settings:

Clear all data except DRO type. DRO will load default setup for parameter. After loading default setup, user must search RI once to enable resuming ABS datum function; otherwise to resume the datum by RI is unable;

Message window displays “ALL CLR”, press **ENT** and message windows display “PASSWORD” indicating the operator to input password; Press 2000 + **ENT** in turn to load default value;

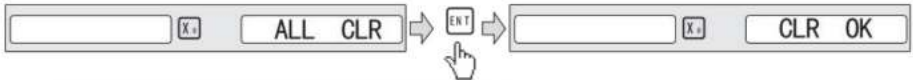

## 3.2.17 Shrinkage Ratio enable or disable.

Message window displays “SRK OFF” to disable Shrinkage rate function. Press **ENT** to enable Shrinkage rate function in Message window displays “SRK ON” :

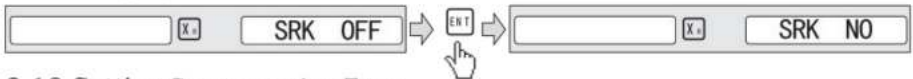

## 3.2.18 Setting Compensation Type

Message window displays “SEL COMP” which indicates the step is to compensation type. Press **X0** to change the compensation type for X axis; Press **Y0** to change the compensation type for Y axis; Press **Z0** to change the compensation type for Z axis; Example for X axis:

Press **X0** to scroll through the not compensation type, the Linear compensation type, the non-linear compensation type.

“no-CO” means the compensation type is not compensation type;

“LinE-CO” means the compensation type is linear compensation type.

“non-LinE” means the compensation type is non-linear linear compensation type;

Example for X axis: currently in the not compensation type, to toggle to the linear compensation type;

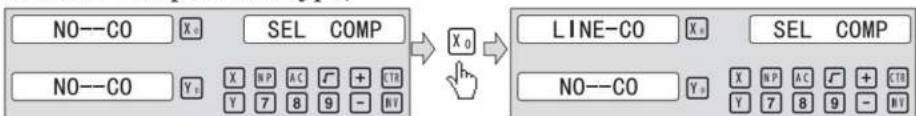

## Parameters settings

## 3.2.19 Inch display, set the number of digits after the decimal point

In the inch display mode, the number of digits after the decimal point is set, the factory default digit is "4", press "X0" to set, can be set according to actual needs.

3.2.20 Setting EDM: it is not recommended that you set the default value yourself, EDM function, Set the relay off on time.

## 3.2.21 Setting Linearity Compensation.

Message window displays "LIN COMP" which indicates the step is to Linearity Compensation. Compensate the linear error to make display value equals to standard value.

The calculation of compensation rectifying coefficient:

$$\text{Coefficient} = \frac{(\text{Measurement} - \text{Standard value}) \times 1000.000}{\text{Standard value}}$$

Example for X axis:

Measurement 200.020mm

Standard value 200.000mm

Rectifying coefficient= (200.020-200) \* 1000 /200 =-0.01mm/m

Input compensation rectifying coefficient 0.01 as follow:

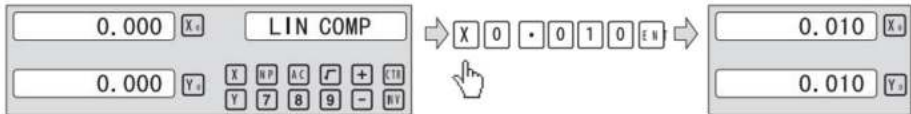

## 3.2.22 Setting the Shrinkage Ratio

Press until "SHRINK" appears in message window;

$$\text{Shrinkage ratio} = \frac{\text{Dimensions of the finished product}}{\text{Dimensions of the working piece}}$$

Set the shrinkage ratio 1.005 as follow;

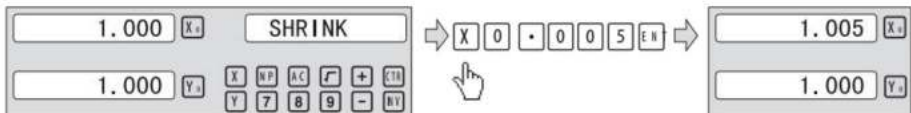







## General Operations

---

### 4、 General Operations;

#### 4.1 Zeroing









Zero the designated axis in normal display state. Zeroing is used to set the current position as datum point as follow;

key		<span style="border: 1px solid black; padding: 2px;">X<sub>0</sub></span>		X axis zero	<table style="width: 100%; border-collapse: collapse;"> <tr> <td style="width: 80%; border: 1px solid gray; padding: 2px;">0.000</td> <td style="width: 20%; border: 1px solid gray; padding: 2px;"><span style="border: 1px solid black; padding: 2px;">X<sub>0</sub></span></td> </tr> <tr> <td style="border: 1px solid gray; padding: 2px;">0.000</td> <td style="border: 1px solid gray; padding: 2px;"><span style="border: 1px solid black; padding: 2px;">Y<sub>0</sub></span></td> </tr> <tr> <td style="border: 1px solid gray; padding: 2px;">0.000</td> <td style="border: 1px solid gray; padding: 2px;"><span style="border: 1px solid black; padding: 2px;">Z<sub>0</sub></span></td> </tr> </table>	0.000	<span style="border: 1px solid black; padding: 2px;">X<sub>0</sub></span>	0.000	<span style="border: 1px solid black; padding: 2px;">Y<sub>0</sub></span>	0.000	<span style="border: 1px solid black; padding: 2px;">Z<sub>0</sub></span>
0.000	<span style="border: 1px solid black; padding: 2px;">X<sub>0</sub></span>										
0.000	<span style="border: 1px solid black; padding: 2px;">Y<sub>0</sub></span>										
0.000	<span style="border: 1px solid black; padding: 2px;">Z<sub>0</sub></span>										
key		<span style="border: 1px solid black; padding: 2px;">Y<sub>0</sub></span>		Y axis zero							
key		<span style="border: 1px solid black; padding: 2px;">Z<sub>0</sub></span>		Z axis zero							

X<sub>0</sub> or Y<sub>0</sub> or Z<sub>0</sub> will be return to the original data before the reset.

#### 4.2 Preset Data to Designated Axis



Preset a value to current position for a designated axis in normal display state.

<table style="width: 100%; border-collapse: collapse;"> <tr><td style="width: 80%; border: 1px solid gray; padding: 2px;">25.400</td><td style="width: 20%; border: 1px solid gray; padding: 2px;"><span style="border: 1px solid black; padding: 2px;">X<sub>0</sub></span></td></tr> <tr><td style="border: 1px solid gray; padding: 2px;">50.800</td><td style="border: 1px solid gray; padding: 2px;"><span style="border: 1px solid black; padding: 2px;">Y<sub>0</sub></span></td></tr> <tr><td style="border: 1px solid gray; padding: 2px;">76.200</td><td style="border: 1px solid gray; padding: 2px;"><span style="border: 1px solid black; padding: 2px;">Z<sub>0</sub></span></td></tr> </table>	25.400	<span style="border: 1px solid black; padding: 2px;">X<sub>0</sub></span>	50.800	<span style="border: 1px solid black; padding: 2px;">Y<sub>0</sub></span>	76.200	<span style="border: 1px solid black; padding: 2px;">Z<sub>0</sub></span>			<span style="border: 1px solid black; padding: 2px;">X</span>	<span style="border: 1px solid black; padding: 2px;">1</span>	<span style="border: 1px solid black; padding: 2px;">8</span>	<span style="border: 1px solid black; padding: 2px;">0</span>	<span style="border: 1px solid black; padding: 2px;">.</span>	<span style="border: 1px solid black; padding: 2px;">0</span>	<span style="border: 1px solid black; padding: 2px;">1</span>	<span style="border: 1px solid black; padding: 2px;">0</span>	<span style="border: 1px solid black; padding: 2px;">ENT</span>		<table style="width: 100%; border-collapse: collapse;"> <tr><td style="width: 80%; border: 1px solid gray; padding: 2px;">180.010</td><td style="width: 20%; border: 1px solid gray; padding: 2px;"><span style="border: 1px solid black; padding: 2px;">X<sub>0</sub></span></td></tr> <tr><td style="border: 1px solid gray; padding: 2px;">586.010</td><td style="border: 1px solid gray; padding: 2px;"><span style="border: 1px solid black; padding: 2px;">Y<sub>0</sub></span></td></tr> <tr><td style="border: 1px solid gray; padding: 2px;">888.660</td><td style="border: 1px solid gray; padding: 2px;"><span style="border: 1px solid black; padding: 2px;">Z<sub>0</sub></span></td></tr> </table>	180.010	<span style="border: 1px solid black; padding: 2px;">X<sub>0</sub></span>	586.010	<span style="border: 1px solid black; padding: 2px;">Y<sub>0</sub></span>	888.660	<span style="border: 1px solid black; padding: 2px;">Z<sub>0</sub></span>
25.400	<span style="border: 1px solid black; padding: 2px;">X<sub>0</sub></span>																								
50.800	<span style="border: 1px solid black; padding: 2px;">Y<sub>0</sub></span>																								
76.200	<span style="border: 1px solid black; padding: 2px;">Z<sub>0</sub></span>																								
180.010	<span style="border: 1px solid black; padding: 2px;">X<sub>0</sub></span>																								
586.010	<span style="border: 1px solid black; padding: 2px;">Y<sub>0</sub></span>																								
888.660	<span style="border: 1px solid black; padding: 2px;">Z<sub>0</sub></span>																								
<table style="width: 100%; border-collapse: collapse;"> <tr><td style="width: 80%; border: 1px solid gray; padding: 2px;">50.800</td><td style="width: 20%; border: 1px solid gray; padding: 2px;"><span style="border: 1px solid black; padding: 2px;">Y<sub>0</sub></span></td></tr> <tr><td style="border: 1px solid gray; padding: 2px;">76.200</td><td style="border: 1px solid gray; padding: 2px;"><span style="border: 1px solid black; padding: 2px;">Z<sub>0</sub></span></td></tr> </table>	50.800	<span style="border: 1px solid black; padding: 2px;">Y<sub>0</sub></span>	76.200	<span style="border: 1px solid black; padding: 2px;">Z<sub>0</sub></span>			<span style="border: 1px solid black; padding: 2px;">Y</span>	<span style="border: 1px solid black; padding: 2px;">5</span>	<span style="border: 1px solid black; padding: 2px;">8</span>	<span style="border: 1px solid black; padding: 2px;">6</span>	<span style="border: 1px solid black; padding: 2px;">.</span>	<span style="border: 1px solid black; padding: 2px;">0</span>	<span style="border: 1px solid black; padding: 2px;">1</span>	<span style="border: 1px solid black; padding: 2px;">0</span>	<span style="border: 1px solid black; padding: 2px;">ENT</span>		<table style="width: 100%; border-collapse: collapse;"> <tr><td style="width: 80%; border: 1px solid gray; padding: 2px;">586.010</td><td style="width: 20%; border: 1px solid gray; padding: 2px;"><span style="border: 1px solid black; padding: 2px;">Y<sub>0</sub></span></td></tr> <tr><td style="border: 1px solid gray; padding: 2px;">888.660</td><td style="border: 1px solid gray; padding: 2px;"><span style="border: 1px solid black; padding: 2px;">Z<sub>0</sub></span></td></tr> </table>	586.010	<span style="border: 1px solid black; padding: 2px;">Y<sub>0</sub></span>	888.660	<span style="border: 1px solid black; padding: 2px;">Z<sub>0</sub></span>				
50.800	<span style="border: 1px solid black; padding: 2px;">Y<sub>0</sub></span>																								
76.200	<span style="border: 1px solid black; padding: 2px;">Z<sub>0</sub></span>																								
586.010	<span style="border: 1px solid black; padding: 2px;">Y<sub>0</sub></span>																								
888.660	<span style="border: 1px solid black; padding: 2px;">Z<sub>0</sub></span>																								
<table style="width: 100%; border-collapse: collapse;"> <tr><td style="width: 80%; border: 1px solid gray; padding: 2px;">76.200</td><td style="width: 20%; border: 1px solid gray; padding: 2px;"><span style="border: 1px solid black; padding: 2px;">Z<sub>0</sub></span></td></tr> </table>	76.200	<span style="border: 1px solid black; padding: 2px;">Z<sub>0</sub></span>			<span style="border: 1px solid black; padding: 2px;">Z</span>	<span style="border: 1px solid black; padding: 2px;">8</span>	<span style="border: 1px solid black; padding: 2px;">8</span>	<span style="border: 1px solid black; padding: 2px;">8</span>	<span style="border: 1px solid black; padding: 2px;">.</span>	<span style="border: 1px solid black; padding: 2px;">6</span>	<span style="border: 1px solid black; padding: 2px;">6</span>	<span style="border: 1px solid black; padding: 2px;">0</span>	<span style="border: 1px solid black; padding: 2px;">ENT</span>		<table style="width: 100%; border-collapse: collapse;"> <tr><td style="width: 80%; border: 1px solid gray; padding: 2px;">888.660</td><td style="width: 20%; border: 1px solid gray; padding: 2px;"><span style="border: 1px solid black; padding: 2px;">Z<sub>0</sub></span></td></tr> </table>	888.660	<span style="border: 1px solid black; padding: 2px;">Z<sub>0</sub></span>								
76.200	<span style="border: 1px solid black; padding: 2px;">Z<sub>0</sub></span>																								
888.660	<span style="border: 1px solid black; padding: 2px;">Z<sub>0</sub></span>																								



#### 4.3 Toggle Display Unit between inch and mm

Length can be displayed either in “mm” (metric) or “inch” (imperial). Display unit can be toggled between mm and inch.

Example: Display value toggle from mm to inch;

<table style="width: 100%; border-collapse: collapse;"> <tr><td style="width: 80%; border: 1px solid gray; padding: 2px;">25.400</td><td style="width: 20%; border: 1px solid gray; padding: 2px;"><span style="border: 1px solid black; padding: 2px;">X<sub>0</sub></span></td></tr> <tr><td style="border: 1px solid gray; padding: 2px;">50.800</td><td style="border: 1px solid gray; padding: 2px;"><span style="border: 1px solid black; padding: 2px;">Y<sub>0</sub></span></td></tr> <tr><td style="border: 1px solid gray; padding: 2px;">76.200</td><td style="border: 1px solid gray; padding: 2px;"><span style="border: 1px solid black; padding: 2px;">Z<sub>0</sub></span></td></tr> </table>	25.400	<span style="border: 1px solid black; padding: 2px;">X<sub>0</sub></span>	50.800	<span style="border: 1px solid black; padding: 2px;">Y<sub>0</sub></span>	76.200	<span style="border: 1px solid black; padding: 2px;">Z<sub>0</sub></span>	mm		<span style="border: 1px solid black; padding: 2px;">mm</span>			inch	<table style="width: 100%; border-collapse: collapse;"> <tr><td style="width: 80%; border: 1px solid gray; padding: 2px;">1.0000</td><td style="width: 20%; border: 1px solid gray; padding: 2px;"><span style="border: 1px solid black; padding: 2px;">X<sub>0</sub></span></td></tr> <tr><td style="border: 1px solid gray; padding: 2px;">2.0000</td><td style="border: 1px solid gray; padding: 2px;"><span style="border: 1px solid black; padding: 2px;">Y<sub>0</sub></span></td></tr> <tr><td style="border: 1px solid gray; padding: 2px;">3.0000</td><td style="border: 1px solid gray; padding: 2px;"><span style="border: 1px solid black; padding: 2px;">Z<sub>0</sub></span></td></tr> </table>	1.0000	<span style="border: 1px solid black; padding: 2px;">X<sub>0</sub></span>	2.0000	<span style="border: 1px solid black; padding: 2px;">Y<sub>0</sub></span>	3.0000	<span style="border: 1px solid black; padding: 2px;">Z<sub>0</sub></span>
25.400	<span style="border: 1px solid black; padding: 2px;">X<sub>0</sub></span>																		
50.800	<span style="border: 1px solid black; padding: 2px;">Y<sub>0</sub></span>																		
76.200	<span style="border: 1px solid black; padding: 2px;">Z<sub>0</sub></span>																		
1.0000	<span style="border: 1px solid black; padding: 2px;">X<sub>0</sub></span>																		
2.0000	<span style="border: 1px solid black; padding: 2px;">Y<sub>0</sub></span>																		
3.0000	<span style="border: 1px solid black; padding: 2px;">Z<sub>0</sub></span>																		

Example: Display value toggle from inch to mm;

<table style="width: 100%; border-collapse: collapse;"> <tr><td style="width: 80%; border: 1px solid gray; padding: 2px;">1.0000</td><td style="width: 20%; border: 1px solid gray; padding: 2px;"><span style="border: 1px solid black; padding: 2px;">X<sub>0</sub></span></td></tr> <tr><td style="border: 1px solid gray; padding: 2px;">2.0000</td><td style="border: 1px solid gray; padding: 2px;"><span style="border: 1px solid black; padding: 2px;">Y<sub>0</sub></span></td></tr> <tr><td style="border: 1px solid gray; padding: 2px;">3.0000</td><td style="border: 1px solid gray; padding: 2px;"><span style="border: 1px solid black; padding: 2px;">Z<sub>0</sub></span></td></tr> </table>	1.0000	<span style="border: 1px solid black; padding: 2px;">X<sub>0</sub></span>	2.0000	<span style="border: 1px solid black; padding: 2px;">Y<sub>0</sub></span>	3.0000	<span style="border: 1px solid black; padding: 2px;">Z<sub>0</sub></span>	inch		<span style="border: 1px solid black; padding: 2px;">mm</span>			mm	<table style="width: 100%; border-collapse: collapse;"> <tr><td style="width: 80%; border: 1px solid gray; padding: 2px;">25.400</td><td style="width: 20%; border: 1px solid gray; padding: 2px;"><span style="border: 1px solid black; padding: 2px;">X<sub>0</sub></span></td></tr> <tr><td style="border: 1px solid gray; padding: 2px;">50.800</td><td style="border: 1px solid gray; padding: 2px;"><span style="border: 1px solid black; padding: 2px;">Y<sub>0</sub></span></td></tr> <tr><td style="border: 1px solid gray; padding: 2px;">76.200</td><td style="border: 1px solid gray; padding: 2px;"><span style="border: 1px solid black; padding: 2px;">Z<sub>0</sub></span></td></tr> </table>	25.400	<span style="border: 1px solid black; padding: 2px;">X<sub>0</sub></span>	50.800	<span style="border: 1px solid black; padding: 2px;">Y<sub>0</sub></span>	76.200	<span style="border: 1px solid black; padding: 2px;">Z<sub>0</sub></span>
1.0000	<span style="border: 1px solid black; padding: 2px;">X<sub>0</sub></span>																		
2.0000	<span style="border: 1px solid black; padding: 2px;">Y<sub>0</sub></span>																		
3.0000	<span style="border: 1px solid black; padding: 2px;">Z<sub>0</sub></span>																		
25.400	<span style="border: 1px solid black; padding: 2px;">X<sub>0</sub></span>																		
50.800	<span style="border: 1px solid black; padding: 2px;">Y<sub>0</sub></span>																		
76.200	<span style="border: 1px solid black; padding: 2px;">Z<sub>0</sub></span>																		

## General Operations

### 4.4 Absolute/Incremental/200 groups SDM

**Function:** The DRO has 3 coordinate display modes: the absolute mode (ABS); the incremental mode (INC) and 200 groups Second Data Memory (SDM) with the range of 00 to 99. Zero point of work-piece is set at the origin point of ABS coordinate. The relative distance between datum of ABS and SDM remains unchanged when ABS datum is changed.

1. Toggle from ABS to INC coordinate;

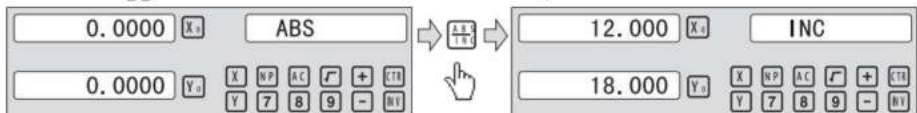

2. Toggle from INC to ABS coordinate;

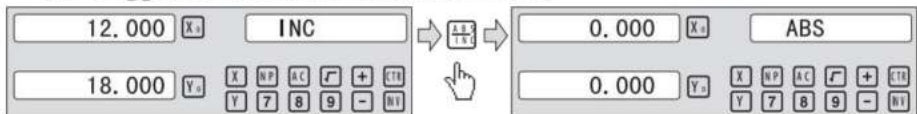

3. Toggle from SMD to ABS coordinate;

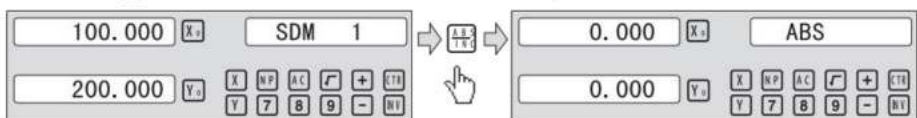

### 4.5 1/2 Function

**Function:** Set the center of work piece as datum by halving the displayed value.



**Example:** Set the center of rectangle as datum as the right figure.

**Steps:**

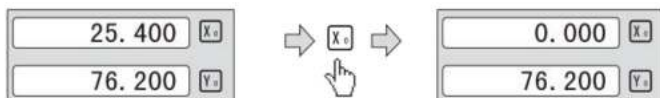
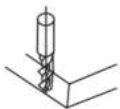
1. Touch one side of the workpiece with the TOOL, then zero the X axis.



2. Breng het GEREEDSCHAP naar de andere kant van het werkstuk en raak het aan.

Druk dan op  +  om op zijn beurt de weergavewaarde van de X-as te bepalen.

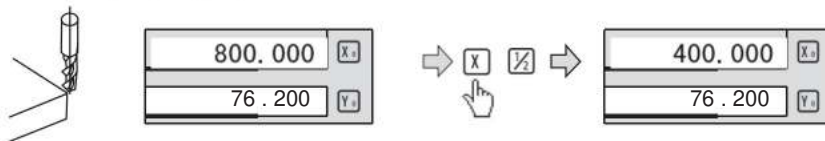

3. Verplaats de rekentafel totdat "0.000" wordt weergegeven op de x-as venster. De positie is het werkstuk' S Center.

4.6 Wis alle SDM-gegevens.

In de AB-modus, om continu op te drukken



tien keer zal ervoor zorgen dat het duidelijk wordt

alle gegevens voor 200 sets SDM. Message-venster geeft USDM weer "CLR".

4.7 Slaapstand

in de niet-ABS-modus, door op de toets te drukken



CAan schakelt alle weergaven uit

en de DRO toegang krijgt tot de slaapstand, en vervolgens op deze toets drukt

zal de DRO weer terugbrengen naar de werkmodus. In de slaapstand

De DRO is nog steeds in werkende staat en registreert daadwerkelijk de TOOL

**movement.**

Voorbeeld: In de niet-ABS-modus kunt u de slaapstand openen door op te drukken

de toets F. In de slaapstand kunt u de toets F indrukken om de



slaapstand.

4.8 Stroomonderbrekingsgeheugen.

Het geheugen wordt gebruikt om de instellingen van de DRO en de machine op te slaan referentiewaarden wanneer POWER is uitgeschakeld.

## 4. 9 zoek het absolute referentiepunt van de schaal

Tijdens het dagelijkse bewerkingsproces komt het vaak voor dat de bewerking kan niet binnen één werkploeg worden voltooid, en daarom DRO moet na het werk worden uitgeschakeld, anders treedt er tijdens het werk een stroomstoring op het bewerkingsproces dat leidt tot het verlies van het werkstukgegevens (werkstuknulpunt), het opnieuw vaststellen van het werkstuknulpunt het gebruik van een kantenzoeker of een andere methode leidt onvermijdelijk tot hogere bewerking met nauwkeurigheid omdat het niet mogelijk is om de werkstuknulpunt exact op de vorige positie. Om de het nauwkeurig herstellen van het werkstuknulpunt en het niet nodig zijn om het werkstuknulpunt opnieuw vast te stellen met behulp van een kantenzoeker of andere methoden, Elke lineaire schaal heeft een repuntlocatie die is uitgerust met ref positie om een geheugenfunctie voor het referentiepunt te bieden.

Het werkprincipe van de ref-datumgeheugenfunctie is als volgt: volgt.

omdat het referentiepunt van de lineaire schaal permanent en vast is, zal het veranderen of verdwijnen nooit wanneer het DRO-systeem wordt uitgeschakeld. Daarom hoeven we alleen de afstand tussen het referentiepunt op te slaan en het werkstuknulpunt (nulpunt) in NIET-vluchtig geheugen. Dan in het geval van een stroomstoring of het uitschakelen van de DRO kunnen wij het probleem verhelpen het werkstuknulpunt (nulpunt) door het display op nul te zetten positie als de opgeslagen afstand vanaf het referentiepunt.

Bij het bewerken van een werkstuk moet een absoluut nulpunt worden ingesteld. Er zijn drie werkingsmodi (REF, AB, LEF, AB):

Voorbeeld: om het werkpunt van de X-as op te slaan

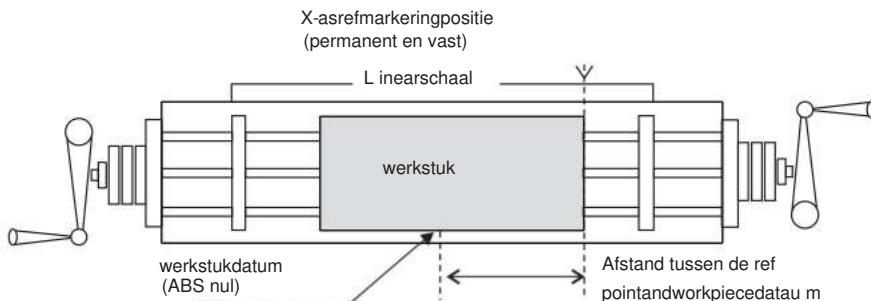

## General Operations

### Example for REF mode :

1、DRO is set in ABS coordinate. Press **REF**, then the message window display “REF” .

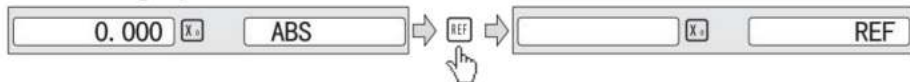

2、Message window displays “REF” , Press **ENT** until “FD\_REF” appears in message window.

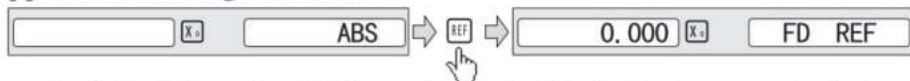

3、Select the axis which need search RI. For instance : select X axis, then press **X** . “X\_REF” is displayed in message window, and X axis window flashes.

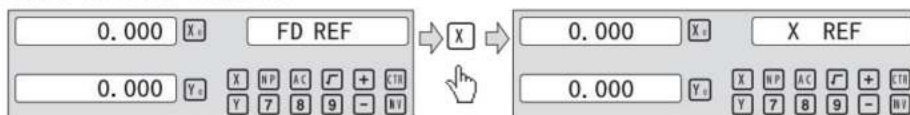

4、Move the machine table .The buzzer sounds when RI is searched, then X window stops flashing and displays the value of the current position .the DRO returns normal display state. Then message window displays “FIND\_X” .

### Example for AB mode :

1、DRO is set in ABS coordinate. Press **REF**, then the message window display “REF” .

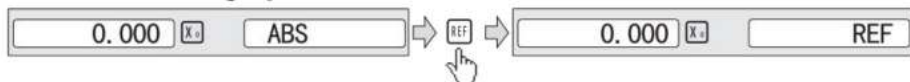

2、Press **▲ ▼**, then the message window display “AB” .



3、Message window displays “AB” , Press **ENT** until “FIND\_AB” appears in message window.

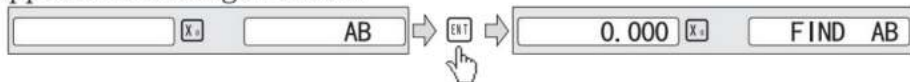

## General Operations

4、 Select the axis which need search RI. For instance : selct X axis, then press **X** . “X\_REF” is displayed in message window, and X axis window flashes.

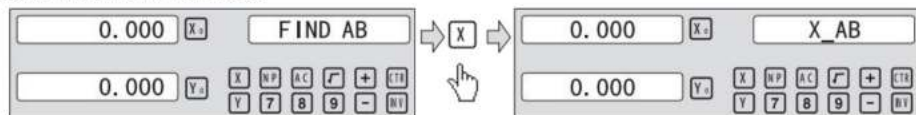

5、 Move the machine table .The buzzer sounds when RI is searched, displays the value of the current position for the absolute datum zero. the DRO returns normal display state. Then message window displays “FIND\_AB” .

### Example for LEF\_AB mode :

1、 DRO is set in ABS coordinate. Press **REF** , then the message window display “REF” .

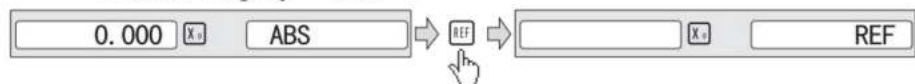

2、 Press **▲** **▼** , then the message window display “AB” .

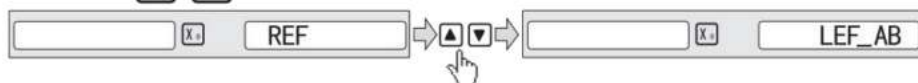

3、 Message window displays “LEF\_AB” , Press **ENT** until “ZERO\_AB” appears in message window.

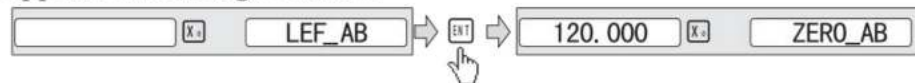

4、 Move the machine table to be set zero position piont. then press **X** , X axis will be zeroing . the current position for the absolute datum zero. the DRO returns normal display state.

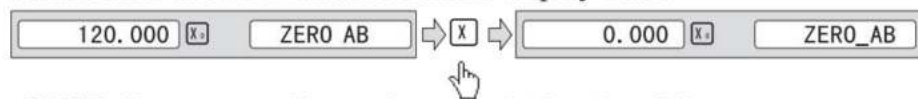

NOTE: Linear range without reference point location of the user

## General Operations

### 4.10 Non Linear Error Compensation

First compensation Type ( Linear or Non-Linear) in parameter setting must be set Non-Linear. Linear scale have a ref point location and find to the Absolute Reference Point will be enable.

Default Non-Linear compensation : 50.

#### Example for Y axis:

Step 1: Search the Absolute Reference Point of Scale;

Step 2: Press **[NP]** , then the message window display “COMP X” .



Step 3: Press **[▲]** **[▼]**, then the message window display “COMP Y”



Step 4: Press **[ENT]**, then the message window display “NUMBER” .

Then input the compensation parameter NUMBER.



Step 5: Press **[▲]** **[▼]**, then message window displays “Y-MSN-1” which indicates the step is to Non Linear Error Compensation.

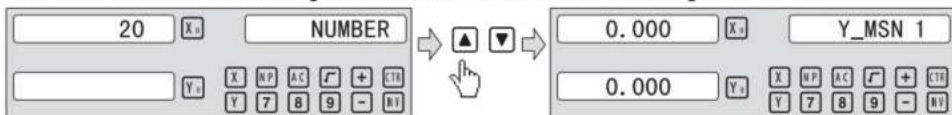

Step 6: Input compensation value .

X window display the value of the measurement value.

Y window display the value of the standard value.

Example for the first compensation point:

Measurement value :68.288mm. Standard value: 68.200mm



Step 7: After input all parameter, the DRO automatically exit.



## 200 Groups SDM coordinate

2、 Set the point sdm1 as the datum of SDM 1. Move the machine worktable to  $x = 60.000$ ,  $y = 45.000$ . Then proess  $X_0$   $Y_0$ .

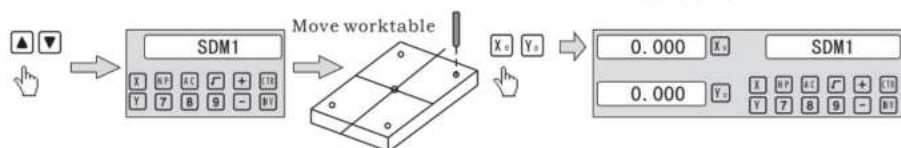

2、 Set the point sdm1 as the datum of SDM 2. Move the machine worktable to  $x = 60.000$ ,  $y = -45.000$ . Then proess  $X_0$   $Y_0$ .

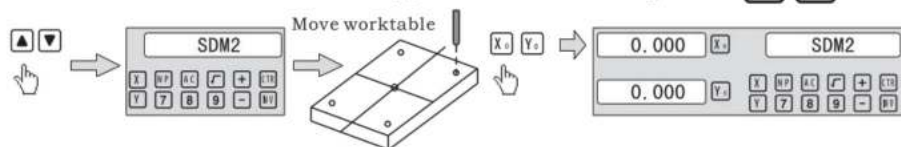

3、 Set the point sdm1 as the datum of SDM 3. Move the machine worktable to  $x = -60.000$ ,  $y = -45.000$ . Then proess  $X_0$   $Y_0$ .

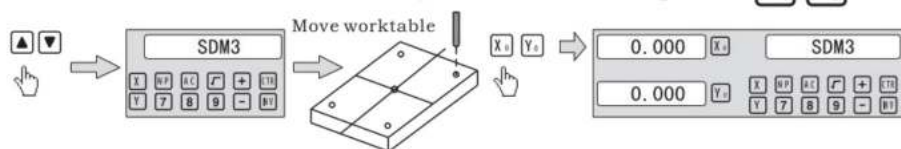

4、 Set the point sdm1 as the datum of SDM 4. Move the machine worktable to  $x = -60.000$ ,  $y = 45.000$ . Then proess  $X_0$   $Y_0$ .

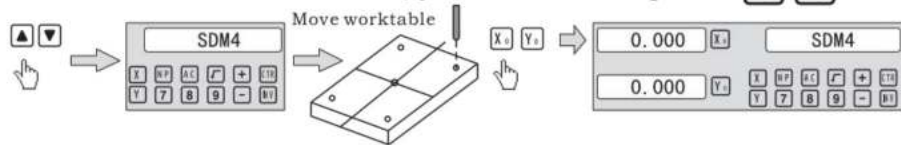

## 5.2 Preset datum of SDM coordinate

There are the same sample as Method 1. First Move the worktable to place the TOOL exactly at the origin of ABS, secondly Enter the ABS Mode as follow.

### Steps:

1、 Move worktable to place the TOOL at the center of the workpiece point O as the datum of ABS. Then zero X axis and Y axis in SDM 1 ; Zero X axis and Y axis in SDM 2 ; Zero X axis and Y axis in SDM 3 ; Zero X axis and Y axis in SDM 4.

## 200 Groups SDM coordinate

2、 Set point sdm1 as the datum of SDM 1. Press  $\blacktriangle$   $\blacktriangledown$ , then the message window display “SDM 1” . Input  $x = 60.000$ ,  $y = 45.000$ .

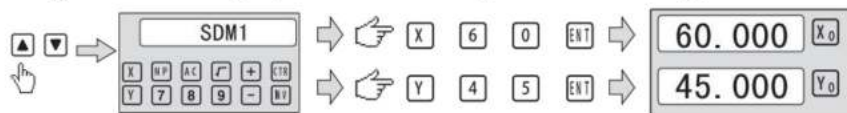

3、 Set point sdm1 as the datum of SDM 2. Press  $\blacktriangle$   $\blacktriangledown$ , then the message window display “SDM 2” . Input  $x = -60.000$ ,  $y = 45.000$ .



4、 Set point sdm1 as the datum of SDM 3. Press  $\blacktriangle$   $\blacktriangledown$ , then the message window display “SDM 3” . Input  $x = -60.000$ ,  $y = -45.000$ .



5、 Set point sdm1 as the datum of SDM 4. Press  $\blacktriangle$   $\blacktriangledown$ , then the message window display “SDM 4” . Input  $x = -60.000$ ,  $y = 45.000$ .

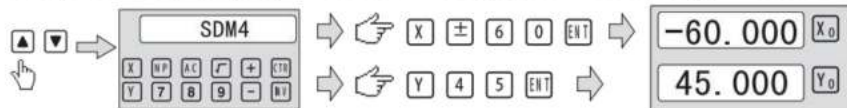

## speciale functie

---

6ÿ speciale functie

## Circumference Holes Processing

### 6.1 Circumference Holes Processing

The Function of PCD Hole positioning on Circumference is used to distribute arc equally, such as boring hole on flange. The right window will show the parameter to be defined when selecting PCD Function.

The Parameters to be defined are:

PCD_XY(XZ,YZ)	Select place
CENTER	Center position
DIA	Diameter of circle
NO_HOLE	Hole number
ST ANG	Starting angle
ED ANG	Ending angle

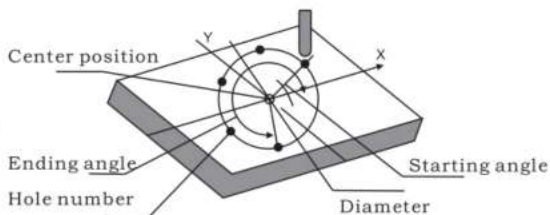

The position of the hole center are calculated automatically after input all parameters. Press or to choose the hole No. and move the machine table until the “0.000” appears in X window , Y window, Z window. It is the position to process a table.

Example for the XY place: Machine hole on circumference as the figure

PCD_XY(XZ,YZ)	XY
CENTER	X=0,000,Y=0.000
DIA	100,000
NO_HOLE	5
ST ANG	30,000
ED ANG	315,000

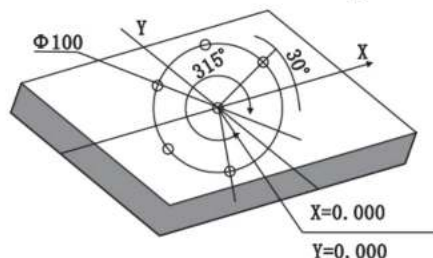

Steps:

1. Set display unit to metric in normal state; Move the machine table until the machine TOOL is aligned with the center of the circle , then zero X axis ,Y axis.

2. Select place.

Press , then the message window display “PCD\_XY” to the Circumference Holes Processing. Press or to select XY place.



## Circumference Holes Processing

## 2. Input center position.

Press **ENT** , then the message window display “CENTER” . X and Y window displays the formerly preset center position. Input X = 0, Y = 0 as follow.

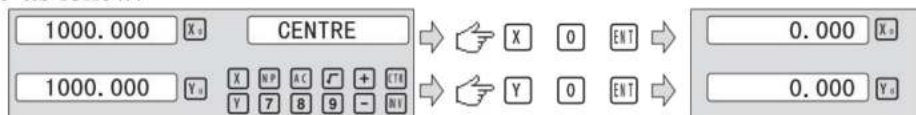

## 4. Input diameter.

Press **▼** until “DIA” appears in the message window. X window displays the formerly preset diameter. Then input the diameter is 100.000.

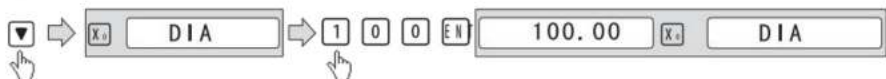

## 5. Input number.

Press **▼** until “NO\_HOLE” appears in the message window. X window displays the formerly preset number. Then press **5** in turn to input number.



## 6. Input starting angle.

Press **▼** until “ST ANG” appears in the message window. X window displays the formerly preset the starting angle. Then press **30** in turn to input the starting angle.



## 7. Input ending angle.

Press **▼** until “ED ANG” appears in the message window. X window displays the formerly preset the ending angle.. Then press **315** in turn to input the ending angle.

## Circumference Holes Processing

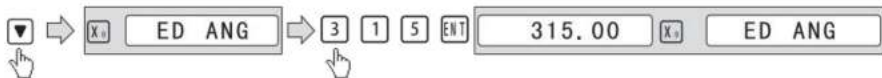

8. Press  until “NO 1” appears in the message window.

It is the position of the first hole to punch where the “0.000” is displayed in X window and Y window by moving the machine table.

After finishing the first hole, press  or  to change holes number.

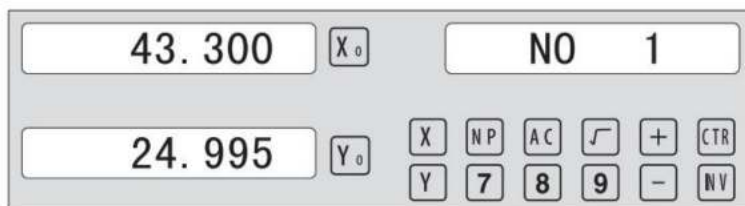

9. After processing all holes, press  to return normal display.

## Linear Holes Processing

### 6.2 Linear Holes Processing

There are two modes to carry out the linear drilling: Length mode and Step mode.

1.LINE S	Step mode
LINE L	Length mode
2.STEP	Step length
LENGTH	Line length
3. ANG	Angle
4. NO.HOLE	Hole number

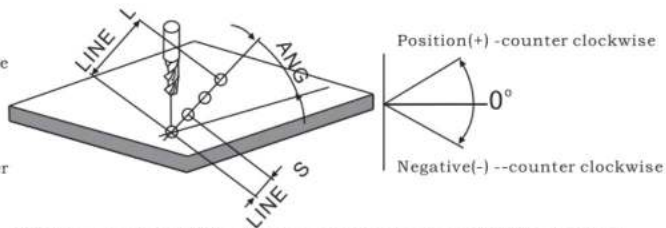

Linear Holes function can simplify the processing multiple holes whose centers are attributed equally on one line.

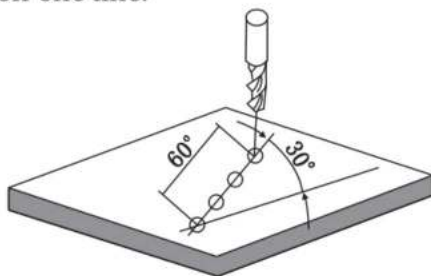

Example :

LINE_L	Length mode
LENGTH	60.000
ANG	30.000
NO.HOLE	4





Steps :

1. Select piece.

Press , then the message window display "LINE\_XY" to the Linear Holes Processing. Press  or  to select XY place.



2. Select Linear Holes mode.

Press , then the message window display "LINE\_S". Press  or  to select "LINE\_L".



3. Input linear length;

Press , then the message window display "LENGTH".

## Linear Holes Processing

X window displays the formerly preset the linear length. Press **6** **0** in turn to input the linear length.



## 4. Input angle;

Message window displays “ANG” which indicates the step is to angle. X window displays the formerly preset the angle. Press **3** **0** in turn to input the angle.



## 5. Input number;

Message window displays “ANG” which indicates the step is to angle. X window displays the formerly preset the number. Press **4** in turn to input the number.



6. Press **▼** until “NO 1” appears in the message window.

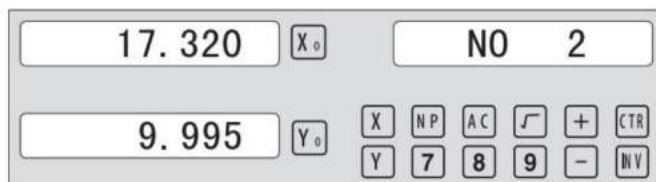

It is the position of the first hole to punch where the “0.000” is displayed in X window and Y window by moving the machine table. After finishing the first hole, press **▲** or **▼** to change holes number.



7. After processing all holes, press **☐** to return normal display.

## 6.3 ARC-verwerking

Voor de ARC-functie zijn TWEE functies beschikbaar: de eenvoudige ARC

Functie en de soepele R-functie · druk op en vervolgens op  om de ARC-functie te openen, pr css  of  voor het selecteren van een soepele ARC-functie of een eenvoudige ARC-functie.

Tijdens de installatie worden normaal gesproken de coördinaten van de machine en de richting van X, Y, Z zijn als volgt. Het werkvlak wordt weergegeven ALS de rechter figuur.

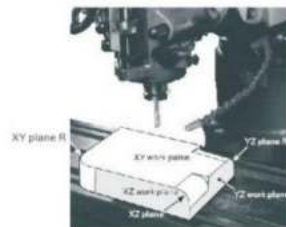
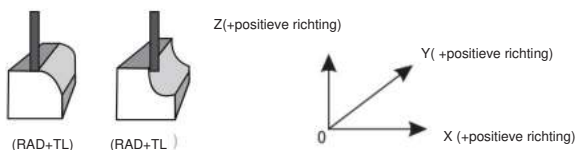

eenvoudige ARC-functie:

wanneer de gladheid niet hoog wordt gevraagd, de EENVOUDIGE BOOG functie wordt normaal gesproken gebruikt voor bewerkingsboog. In de SIMPLE-functie Er worden slechts acht soorten ARC gebruikt voor de machine. De operator hoeft alleen maar Selecteer het type R en voer de parameters van de straal van Arc in MAX CUT en outer Qrc of inner arc. Over het algemeen kan een boog zijn bewerkt door een vlakke sleuf T ze in OOL Of arc TOOL, het verschil tussen verschillende werkvlakken zoals hieronder getoond ·

- |                          |                       |
|--------------------------|-----------------------|
| 1, EENVOUDIG             | eenvoudige verwerking |
| 2, TYPE 1 - 8            | Modus van de ARC.     |
| <b>3, SEL_XY(XZ, YZ)</b> | Selecteer plaats      |
|                          | Boogstraal            |
| 4, RAD                   | Gereedschapsdiameter  |
| 5, TL HEM                | Voerstep              |
| 6y MAXIMALE SNIJDING     | buitenste boog en     |
| 7, RADTL                 | binnenste boog        |
- (alleen voor xy-plaats)

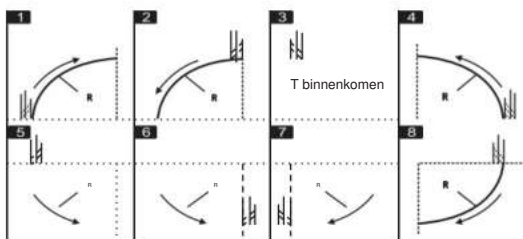

## ARC Processing

---

Smooth ARC function :

Provides maximum flexibility in ARC machining, the ARC sector to be machined by the coordinates of ARC. Very flexible, ARC function can machine virtually all kinds of ARC, ever the intersected ARC. Relatively a bit complicated to operate, operator need to calculate and enter the coordinates of ARC centre, start angle and end angle.

Basic parameter as follow:

1. SMOOTH	Mode of the Smooth ARC processing;
2. SEL_XY(YZ, XZ)	Select place;
3. CENTER	Refer to the position of an center.
4. RAD	Radius of the ARC
5. TL_DIA	Diameter of the TOOL
6. MAX_CUT	Feed step
7. ST_ANG	Starting angle
8. ED_ANG	Ending angle
9. RAD+TL	Outer arc.
RAD-TL	Inner arc.

### Example 1 for the Simple ARC Processing:

Parameters settings as follow:

SIMPLE	Simple mode
TYPE	3
SEL_XY	XY
RAD	80.000
TL_DIA	6.000
MAX_CUT	0.500
RAD+TL	1

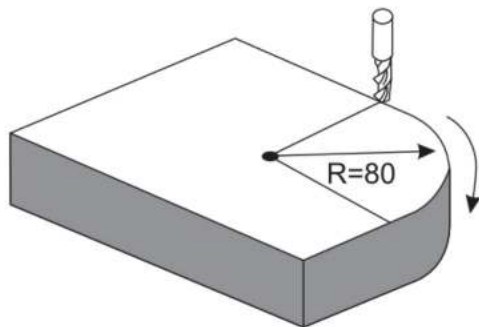

Steps:

1. Select process mode

Press  , then the message window display “SIMPLE” to the ARC Processing. Press  or  to select mode of the simple, The message window display “SIMPLE”

## ARC Processing



2. Input the type:

Press **ENT** until “TYPE” appears in the message window. X-window displays the formerly preset type. Press **3** in turn



3. Select place

Press **ENT** until “SEL\_XY” appears in the message window.

Press **▲** or **▼** to select place to display “SEL\_XY”;



4. Input radius:

Press **ENT** until “RAD” appears in the message window. X-window displays the formerly preset radius of ARC. Press **80** in turn to input the radius.;

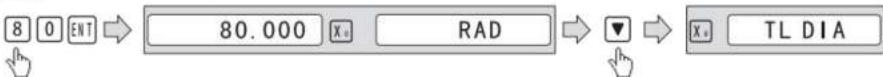

5. Input Diameter of the TOOL

Press **▲** or **▼** until “TL DIA” appears in the message window. X-window displays the formerly preset Diameter of the TOOL. Press **6** in turn to input the Diameter value;



6. Input Feed step (MAX\_CUT);

Press **▲** or **▼** until “MAX\_CUT” appears in the message window. X-window displays the formerly preset MAX\_CUT. Press **0.5** in turn to input the MAX\_CUT value;



## ARC Processing

## 7. Select outer arc or inner arc

Press or until “RAD-TL” appears in the message window. Press or to select place to display “RAD+TL” ;

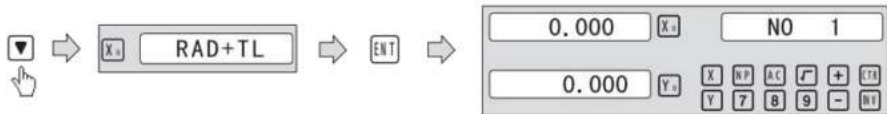

## 8. After inputting all parameters, press the key for machining.

The DRO will display the position of the first point. Retract the axes until the displays read 0.000, Machine the Arc point by point in accordance with the display. After finishing the position of the first point, press or to change position point.

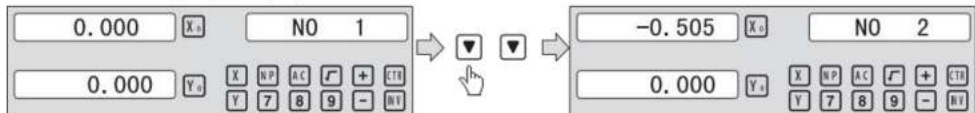

Press to quit R function any time.

**Example 2 for the Simple ARC Processing:**

Parameters settings as follow:

SIMPLE	Simple mode
TYPE	3
SEL_XY	XZ .....
RAD	80.000 .....
TL_DIA	6.000 .....
MAX_CUT	0.500 .....

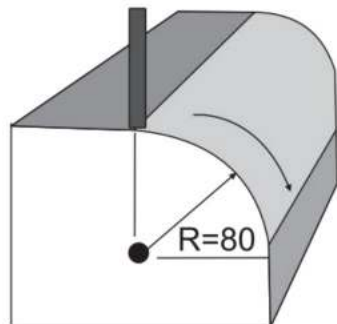

Steps:

1. Press , then the message window display “SIMPLE” to the ARC Processing. Press or to select mode of the simple, The message window display “SIMPLE”

## ARC Processing

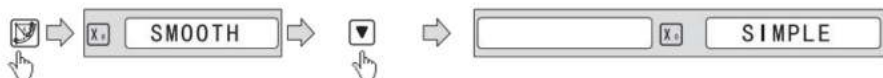

2. Input the type:

Press **ENT** until “TYPE” appears in the message window. X-window displays the formerly preset type. Press **3** in turn



3. Select place

Press **ENT** until “SEL\_XZ” appears in the message window.

Press **▲** or **▼** to select place to display “SEL\_XZ” ;



4. Input radius:

Press **ENT** until “RAD” appears in the message window. X window displays the formerly preset the radius of ARC. Press **80** in turn to input the radius.;



5. Input Diameter of the TOOL

Press **▲** or **▼** until “TL DIA” appears in the message window. X window displays the formerly preset the Diameter of the TOOL. Press **6** in turn to input the Diameter value;



6. Input Feed step (MAX\_CUT);

Press **▲** or **▼** until “MAX\_CUT” appears in the message window. X window displays the formerly preset the MAX\_CUT. Press **0.5** in turn to input the MAX\_CUT value;



## ARC Processing

7. After inputting all parameters, press the key **ENT** for machining.

For 2-axis milling machine table, It is not installed with Z-axis, please press **▲** or **▼** to simulate position of Z-axis. Press **▲** simulate moving to the former process, and press **▼** simulate moving to the next process point.

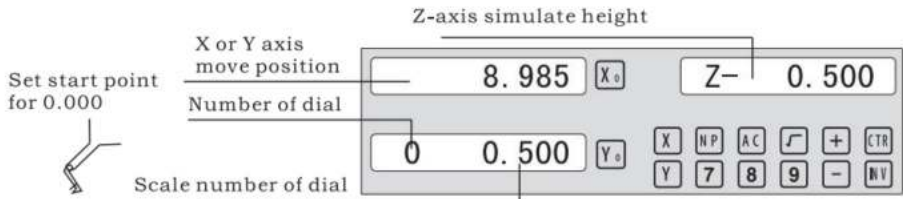

Z-axis simulate height = Number of dial x Z axis Dial + Scale number of dial

Press **▼** to quit R function any time.

### Example 3 for the Smooth ARC function:

Parameters settings as follow:

SMOOTH	Smooth mode
SEL_XY(YZ,XZ)	XY
CENTER	X=0,Y=0
RAD	80.000
TL_DIA	6.000
MAX_CUT	0.500
ST_ANG	0.000
ED_ANG	135.000
RAD+TL	1

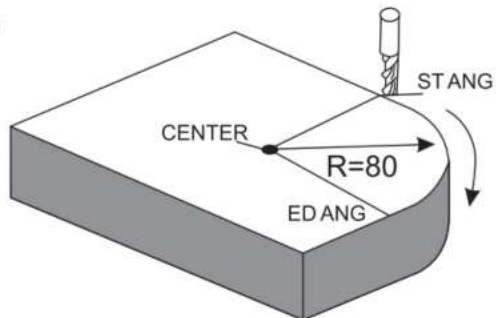

Steps:

1. Press **▼**, then the message window display "SIMPLE" to the ARC Processing. Press **▲** or **▼** to select mode of the simple, The

## ARC Processing

message window display “SMOOTH” ; For 3-axis milling machine table without this step. In second step. Then press **ENT** .

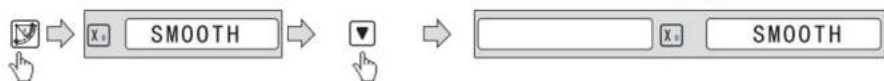

## 2. Select place

Message window display “SEL\_XY” which indicates the select is to place. Press **▲** or **▼** to select place to display “SEL\_XY” ;

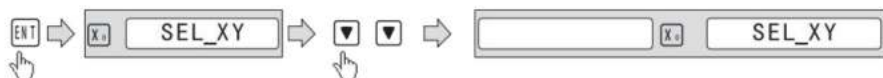

## 3. Input center position.

Press **ENT** , then the message window display “CENTER” . X and Y window displays the formerly preset center position. Input X = 0, Y = 0 as follow.

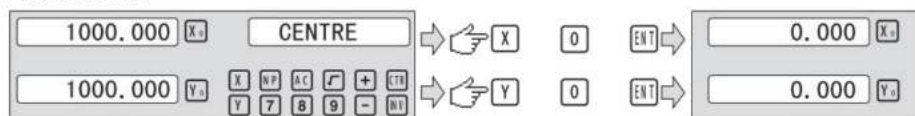

## 4. Input radius:

Press **ENT** until “RAD” appears in the message window. X window displays the formerly preset the radius of ARC. Press **8** **0** in turn to input the radius.;



## 5. Input Diameter of the TOOL

Press **▲** or **▼** until “TL DIA” appears in the message window. X window displays the formerly preset the Diameter of the TOOL. Press **6** in turn to input the Diameter value;



## 6. Invoerfeedstap (MAX\_CUT);

pers  of  totdat UMAX\_CUT app auto's in het bericht

venster. X Venster de spa lys de voorheen vooraf ingestelde de MAX\_CUT. druk op

   om op zijn beurt de MAX CUT-waarde in te voeren;

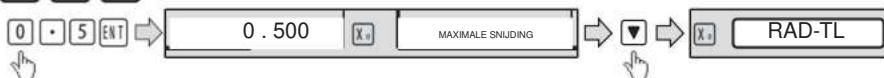

## 7. Invoer starthoek .

pers  totdat "USTANG" in het berichtenvenster verschijnt.x

window de spa lys de voorheen ingestelde beginhoek · Druk vervolgens op

 op zijn beurt de beginhoek invoeren-

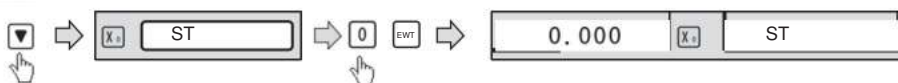

## 8. Invoer eindhoek .

pers  totdat UED ANG" in het berichtenvenster verschijnt. X



venster ispa lys de voorheen vooraf ingestelde eindhoek. Druk vervolgens op 

  op zijn beurt de eindhoek invoeren-



## 9. Selecteer buitenste boog of binnenste boog

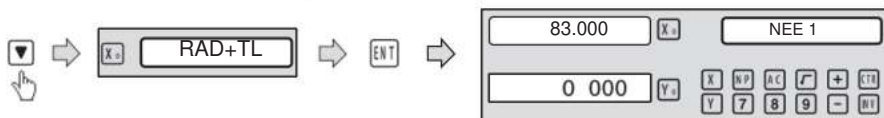

druk  of  totdat "RAD-TL" in het bericht verschijnt

op venster.druk  of  om de plaats te selecteren waar "RAD+TL" moet worden weergegeven;

10. Nadat u alle parameters hebt ingevoerd, **machining.**

De DRO zal de positie van het eerste punt weergeven. Trek de

assen totdat de displays 0.000 aangeven, Bewerk de boog punt voor punt in overeenstemming met de weergave. Na het voltooien van de positie van de eerste

punt,druk  of  om het positiepunt te veranderen.

## ARC Processing

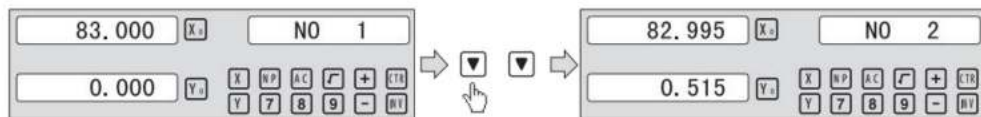

Press  to quit ARC function any time.

#### 6.4 schuine verwerking

Er zijn 2 manieren om de schuine positie te bewerken:

A) op de plaats. b) op de plaats yz, of Xz;

Alleen de volgende parameters hoeven te worden ingevoerd:

INCL Xy(xz,yz)      stel machine plaats xy,yz,0rxz plaats ·

DE                      De hellingshoek van de schuine

DAAR                  De GEREEDSCHAPSdiameter ·

ST POT                Startpositie;

ED KAN                Eindeposting;

Voorbeeld 1 voor de schuine xy-plaats:

wanneer het bewerkingsvlak zich op vlak xy bevindt, zoals het weergegeven onderdeel

Figuur, de schuine hoek van het werkstuk moet worden gekalibreerd

voordat het schuine vlak wordt bewerkt. Daarom , op dit punt de

bewerking van schuine vlakken speelt de rol van het kalibreren van de schuinte ·

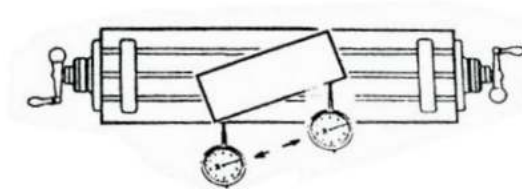

procedure voor het kalibreren van de schuinte

Plaats eerst het werkstuk op de werktafel in de gewenste hoek

van scheefstand ·

- 1) Voer de functie van het schuine vlak in.
- 2) Selecteer de functie van het vlak XY.
- 3) Voer de hellingshoek in

4) Verplaats de werktafel totdat het meetinstrument (zoals een meetklok) geïnstalleerd op de freesmachine raakt het schuinte-kalibratievlak aan, stel het in op nul en verplaats de werktafel over een willekeurige afstand in de richting van de x-as\_

5) Beweeg de werktafel in de afstand van de y-as totdat het display verandert naar nul.



## Oblique Processing

---

6) Change the angle of the work piece to make the workpiece touch the measuring tool and adjust it to zero.

STEPS:



1. Select place

Press , then the message window display "INCL\_XY" to the Oblique Processing. Press  or  to select place to display "SEL\_XY";

Then press  to in next step;



2. Input the angle of obliquity

The message window display "ANG" , X window displays the formerly preset the angle of obliquity. Press   in turn to input the angle of obliquity .



3. Move the workpiece along the X-Axis until the measuring tool touches the workpiece adjust it to zero, and move the worktable for any distance along the X-Axis.



4. Press , display the value of Y-Axis. Move the workpiece along the Y-Axis, change the angle of workpiece to make the obliquity-calibrating plane touch the measuring tool until it turns to zero. Move the worktable until Y-Axis is displayed as zero.

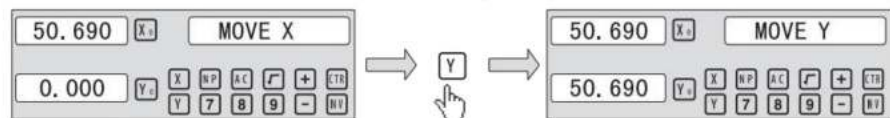

5. Press  to quit oblique function any time.

## Oblique Processing

### Example 2 for the oblique XZ or YZ place:

When the machining plane is on plane XZ or YZ, the function of TOOL inclination can instruct the operator to machine the oblique plane step by step.



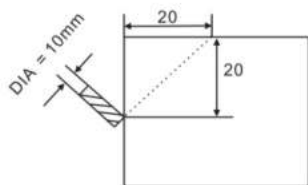
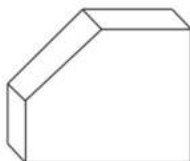

Procedures for using the function of cutter inclination:

When the machining plane is on plane XZ or YZ, first please calibrate the obliquity of the primary spindle nose and set the TOOL:

INCL_XY(XZ,YZ)	INCL_XZ
DIA	10.000
ST_POT	20.000
ED_POT	20.000





#### STEPS:

1. Press , then the message window display “INCL\_XY” to the oblique Processing. Press  or  to select place to display “SEL\_XZ; Then press  to in next step;



2. Input The TOOL Diameter

The message window display “DIA” , X window displays the formerly preset the angle of obliquity. Press   in turn to input the TOOL Diameter of obliquity . OK, then press  to in next step;



3. Input ST\_POT;

The message window display “ST\_POT” , X and Y window displays the formerly preset the stating position of obliquity. Input X= 0, Y = -20.000. OK, then press  to in next step;

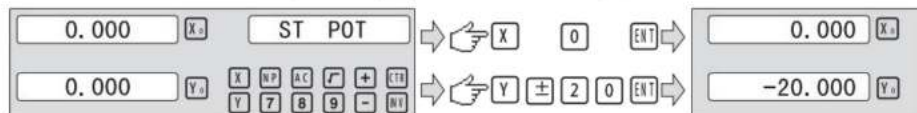



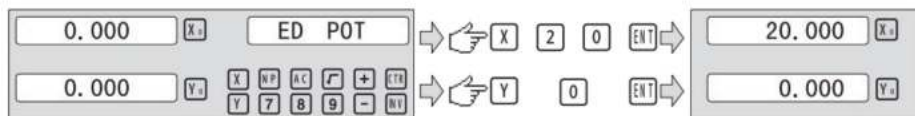

## Oblique Processing

### 4. Input ED\_POT;

The message window display “ED\_POT” , X and Y window displays the formerly preset the starting position of obliquity. Input X= 20.000, Y = 0.000 .



### 5. After input all parameter, press the key for machining.

For 2-axis milling machine table , It is not installed with Z-axis, please press  or  to simulate position of Z-axis. Press  simulate moving to the former process, and press  simulate moving to the next process point.

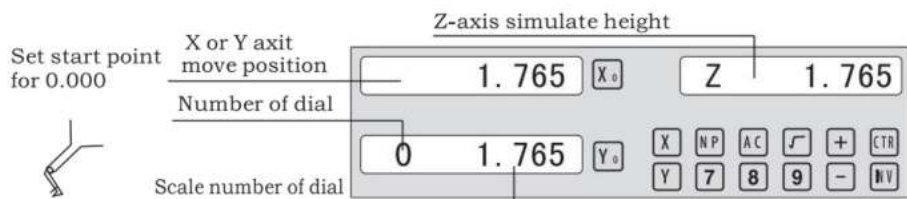

Z-axis simulate height = Number of dial x Z axis Dial + Scale number of dial

Press  to quit **oblique** function any time.

## Slope Processing



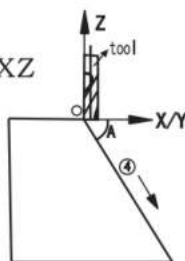

## 6.5 Slope Processing

This function can calculate the position of every processing point automatically in processing slope. Only the following parameters need to be inputted:

XZ, YZ	Set machine place YZ, or XZ
ANG	The inclination angle
Z_STEP	The slope length each time processing



**Example 1 for the Slope XZ place;**

Step 1. Select place

Press , then the message window display "XZ" to the slope Processing. Press  or  to select place to display "SEL\_XY"; Then press  to in next step;





Step 2. Input the angle of slope

The message window display "ANG", X window displays the formerly preset the angle of slope. Press   in turn.



Step 3. Input Z\_step;

The message window display "Z STEP", X window displays the formerly preset the stating position of slope. Input    in turn.



Step 4: Finishing the ALL processing . Press  to quit slope function any time.

## Chambering Processing

### 6.6 Chambering Processing

1,FLAT\_XY: machine place; 2, DIA:diameter of TOOL; 3, CENTER: center of the chambering ; 4, SIZE: size of the chambering ;

Figure as follow:

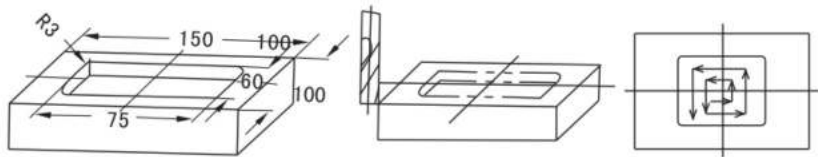

STEPS:

1. Press , then the message window display “FLAT\_XY” to the Chambering Processing.



2. Input DIA of the TOOL;





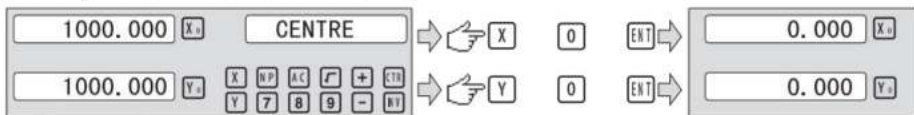

3. Input the center coordinate;

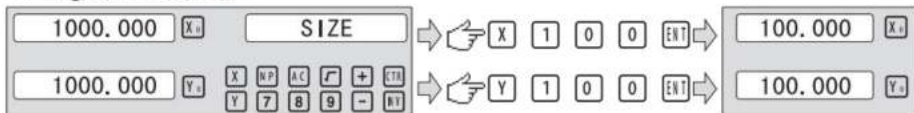

4. Input the size;



5. process Chambering;

Move the machine until the display of the axis is zero,ie, the position of the first point. Machine the first point . Display the next machining point by pressing  or  .On the completion of machining, the right window shows OVER. Press  or , the system will goto the first position for the next workpiece. Press  to quit the Chambering Function.

## The Tool Diameter Compensation Function

### 6.7 The Tool Diameter Compensation Function

Without TOOL compensation, the operator has to move the TOOL for an additional distance of the diameter of the TOOL along each side when machining the four 150 and 100 sides of a workpiece to finish machining the whole brim. The digital readouts shall automatically compensate when the TOOL compensation function is enable.

Note: the TOOL compensation is made in the direction of X and Yaxis.

Procedures:

- 1) . Enter the function of compensating the diameter of the TOOL.
- 2) . Select one of the (four) preset machining modes.
- 3). Input the diameter of the TOOL.
- 4) . Enter machining.

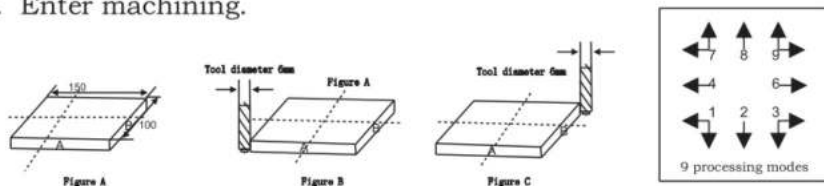

Step1: press  $\frac{D}{1}$  to enter the TOOL compensation Function. then the message window display “TYPE” .Press **9** .



Step 2: input the diameter of the TOOL; Press **1** **0** in turn..



Step 3: Press  $\nabla$  to the machining Mode.

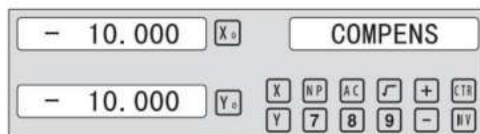

Machining of 2 side planes can be done by moving the TOOL until X-Axis is 150.000 and Y-Axis is 100.000.Press the Key  $\frac{D}{3}$  to quit the Function.

## The Tool Diameter Compensation Function

---

### 6.8 Digital Filter of the Grinding Machine

When machine a work-piece by grinder, the display values quickly due to the vibration of grinder. User can not see display value clearly. Grinder DRO provides display value filter function to disable the quake change of display value.

STEPS:

1. Enter display value filter function.

In normal display state, press **SFT** to simultaneously, enter display value filter function.

2. Exit display value filter function;

Press **SFT** , exit display value filter function;

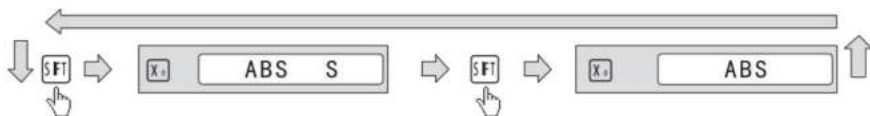

## 6. 9 De functie

### 6.9.1 200 sets TOOL-bibliotheken

Er is altijd een ander GEREEDSCHAP nodig bij het verwerken van verschillende onderdelen · Voor gemakkelijke bediening, de La de digitale uitlezingen hebben de functie van 200 sets TOOL-bibliotheken ·

Let op: alleen als de la is uitgerust met het gereedschapsinstelblok kunnen de 200 sets TOOL , Libs worden gebruikt.

1. stel een datum TOOL in. Na het instellen van het gereedschap, nul x-as en Z-as, de stel nulpunt van absolute coördinaat in ·

2. Bepaal de grootte van TOOL I en datumTOOL, positie van TOOL relatief tot nul van absolute coördinaten en datum tool · AS Afbeelding 6-1. De relatieve grootte van TOOL 2 is AS volgt x-as 25-30=- 5 , Z-as 20-10=10 ·

3. Sla het TOOL-nummer en de grootte op in de digitale uitlezing ·

4. Het aantal TOOLS kan willekeurig worden ingevoerd, de digitale uitlezingen zal de positie van het gereedschap weergeven op absolute coördinaat nul · Verplaatst de totdat de X-as en de Z-as beide nul · 5 weergeven. TOOL Libs kunnen de 200 sets met gegevens van gereedschappen opslaan.

6. De TOOL Libs moeten in de openingsstatus worden gebruikt. De 200 sets rooi Libs kan worden geopend door continu op te drukken  tien keer totdat het rechtervenster TL - OPEN knippert en er een teken "21" wordt weergegeven links van het rechter informatievenster. De Mark geeft de operator CAn de 200 sets TOOL Lib s. continu instellen of herzien

door op de toets te  tien keer zal ervoor zorgen dat de 200 sets TOOL Libs worden gedrukt, sluit het rechterraam en knippert TL - CLOSE en het merkteken verdwijnen · wanneer het merkteken "21" verdwijnt, kunnen de 200 sets TOOL Libs niet herzien worden·

De bewerkingen voor TOOL-gegevens en het aanroepen van TOOL worden ALS volgt weergegeven: stap 1: Voer in de ABS-status de gegevens van de 200 sets TOOL-bibliotheken in.

het openen van de 200 sets TOOL Libs door continu op de toets te drukken

 tien keer A. Mark "" zal verschijnen Oor bij het linker raam van de rechter infovenster.

## Lathe Function

stap 2: druk op **TOOL** om TOEGANG te krijgen tot de invoerstatus. Input rooi 1 data:

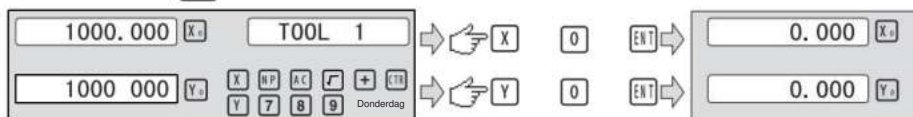

stap 3: invoer TOOL 2-gegevens:

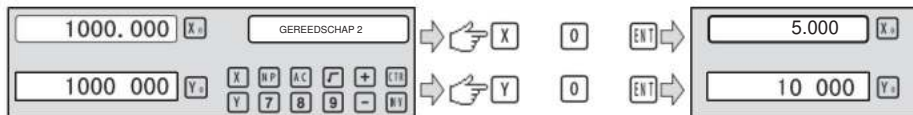

stap 4: druk op om door te gaan met het invoeren van de gegevens van het volgende gereedschap. DOOR op te drukken

nummer en de sleutel de operator kan direct de speciale invoer invoeren

gereedschapsgegevens. druk op **TOOL** raakt

Nadat de TOOL-bibliotheken zijn ingesteld, gebruikt u de TOOL-bibliotheken volgens de volgende handelingen monteer eerst het tweede gereedschap .

stap 5: Toegang krijgen tot de gebruiksstatus via pr css

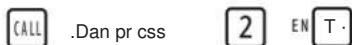

stap G: druk op **▲** of **▼** . Selecteer de basisrol. Druk vervolgens op



stap 7: druk op **CALL** de functie verlaten;

Opmerking:

wanneer het basisgereedschap wordt gebruikt , de as kan niet op nul worden gezet in ABS-status .

wanneer de anderen worden gebruikt , de as kan alleen op nul worden gezet in de INC-status .

### 6 . 9 . 2 Taperfunctie

Voor het draaien van het werkstuk met conus kan de conus van het werkstuk gemeten worden in de verwerking;

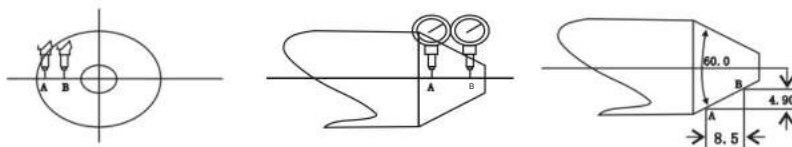

## Lathe Function

### Operations :

AS-figuur, contactvlak A van werkstuk met hendeluitlezingen en reset het hendeluitlezingspunt naar nul ·

stap 1: druk op het  berichtvenster en geef vervolgens "UMEASU" weer  
papierverwerking · Beweeg de hendeluitlezing naar het oppervlak B Totdat de  
hendeluitlezingen punt AS volgen;



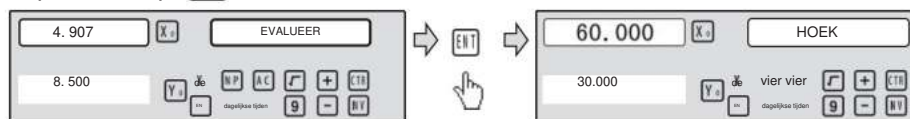

stap 2: druk op  om te berekenen.



stap 3: druk op  de functie verlaten;

### 6 . 9 . 3 R/D-functie

Voor 2-assige draaibank en 3-assige draaibank, druk , De weergavemodus  
of x-as wordt omgeschakeld tussen Radius en Diameter. Wanneer de x-as voor  
weergave van Diameter, Een merk u  zal verschijnen aan de linkerkant van de rechterkant  
informatievenster, maar wanneer X-as voor weergave van ia meter  
" " verdwijnen · alleen de x-as heeft de functie van de diameter/straal  
transformation.

### 6 . 9 . 4 Y + Z-functie (alleen van toepassing op: 3 assen La)

Voor 3 assen La de, de teller van y-as en de teller van z-as

Kan worden toegevoegd aan de weergave in de Z-as door op de toets te drukken ,

druk dan op de toets CAN om de y + Z-functie te annuleren ·

6.10 EDM (speciale aanpassingsfunctie, als u deze moet kopen, neem dan contact met ons op)  
 Neem contact op met de dealer om het aan te passen)

1  $\ddot{y}$  Beschrijving: Deze functie wordt gebruikt voor de speciale bewerking van Elektro-ontladingsbewerking (EDM). Wanneer de ingestelde streefwaarde van EDM Z-as is gelijk aan de huidige waarde, de digitale uitlezing zal de schakelsignaal om EDM te besturen en de dieptebewerking te stoppen.

De instelling van de Z-asrichting van de digitale uitlezing wordt weergegeven in figuur 1. , dwz Hoe dieper de diepte is, hoe groter de coördinaatwaarde van de Z-as displays · sinds het begin van de bewerking zal de diepte geleidelijk dieper worden en Z-as.

De bewerkingsrichting is afhankelijk van de ingestelde Z-asrichting verdeeld in positieve en negatieve bewerking · wanneer de elektrode daalt en de bewerking wordt van boven naar beneden uitgevoerd, de digitale De uitleeswaarde zal toenemen, dit wordt positieve bewerking (positief) genoemd. De instelling van deze richting is de normale instelling.

wanneer de elektrode ASCEnds en de bewerking wordt uitgevoerd van beneden naar boven zal de digitale uitleeswaarde afnemen · De bewerkingsrichting is negatieve richting (negatief), wat ook wel wordt genoemd negatieve bewerking (weergegeven als figuur 1)

De digitale uitlezing heeft ook andere functies , zoals negatief brandwerende hoogte. Negatieve brandwerende hoogtefunctie is een soort intelligente positie volg controle veiligheidsbeschermingsapparaat. In het proces van de bewerking zal het elektrodeoppervlak de koolstof genereren accumulatie fenomeen. Vanwege de lange tijd of dagelijkse-bewerking zonder te zorgen, bij het genereren van de koolstofaccumulatie en niemand maakt de reiniging, de elektrode zal langzaam toenemen langs de negatieve richting · zodra de elektrode het vloeistofniveau overschrijdt, zal deze vaak vlam vatten en verliezen veroorzaken. Deze functie is alleen ingesteld om te richten bij dit probleem. bij het instellen van een negatieve brandwerende hoogte, en de de verhoogde hoogte van de elektrode overschrijdt de hoogte tussen de elektrode en de diepte van het bewerkte oppervlak (d.w.z. negatieve brandwerende hoogte), de digitale het uitleesscherm knippert voor WQring; tegelijkertijd zal de uitvoer signaal schakelt automatisch EDM uit om de kans op brand te elimineren ·

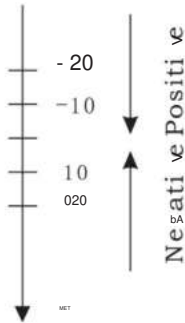

Figuur 1

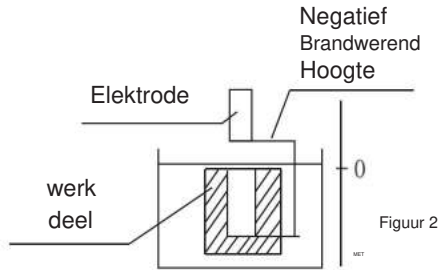

Figuur 2

## 2. Werkwijze:

zie het volgende voorbeeld voor gedetailleerde bewerking

- 1) Stel voor het bewerken eerst elke parameter van DIEPTE in (bewerkingsdiepte); ERRHIGH (negatieve brandwerende hoogte), bewerking richting (POSITIEF / NEGATIEF); uitgangsmodus (AUTO/STOP) en EDM-relaisuitgangsmodus · 2)

Verplaats de hoofdaselektrode van de Z-as zodat deze contact maakt met de werkstukreferentie · A-as op nul zetten of waarde instellen ·

- 3) Voer EDM-bewerking in door de toets pr css te gebruiken  ·

4) De X-as geeft de doelwaarde voor de bewerkingsdiepte weer. De Y-as geeft de doelwaarde voor de bewerkingsdiepte weer.

De weergavewaarde moet diepte zijn. (De waarde op de Y-as is de waarde dat het werkstuk is bewerkt diepte) Z-as zal

weergave van de realtime waarde van de zelfpositie. (De waarde op de Z-as is de positiewaarde van de hoofdaselektrode van de z-as.)

5) begin met bewerken, de weergavewaarde van de Z-as komt geleidelijk dichterbij de doelwaarde, de weergavewaarde van de y-as komt ook geleidelijk dichterbij de streefwaarde. Als de elektrode op dit moment herhaaldelijk omhoog en omlaag gaat, verandert de Z-asweergavewaarde vervolgens, maar de y-asweergave verandert waarde zal niet veranderen, die altijd de bewerkte diepte zal weergeven **value**.

- 6) wanneer de weergavewaarde van de Z-as gelijk is aan de ingestelde doelwaarde,

De schakelaar voor het bereiken van de positie wordt uitgeschakeld, EDM stopt met bewerken, Afhankelijk van de instellingen van de operator zijn er twee soorten exit-modi:

## a) Automatic Mode:

it will automatically exit from EDM machining status and recover to the original state before machining;

## b) Stop Mode:

It will always stay at the machining interface after finishing machining, and you should press **EDM** to exit and back to the original state.

**Operation steps:**

**The DEPTH (machining Depth), ERRHIGH (Negative fireproof height), exit Mode, EDM Relay Output Mode and machining direction should be set.**

**STEPS:**

1. Press **EDM** to enter the EDM Function. Press **▲** to input parameters; Press **▼** to enter EDM machining state.

2. Input DEPTH ( machining depth). Press the key **▲** to set the next parameter.



3. input ERRHIGH ( Negative Fireproof Height ) (undefine) .Press the key **▲** to set the next parameter.



4. Set machining direction(Positive or Negative). Press **1** to select Positive direction. Press **0** to select Negative direction. Press the key **▲** to set the next parameter.



5. Set exit Mode (AUTO Mode or STOP Mode) Press **0** to select AUTO Mode; Press **1** to select STOP Mode ; Press the key **▲** to set the next parameter.

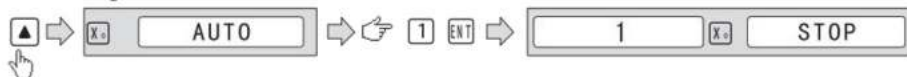

6. Set the Output Mode (Mode 0 or Mode 1); ( undefine ). Press **0** to select Mode 0; Press **1** to select Mode 1.

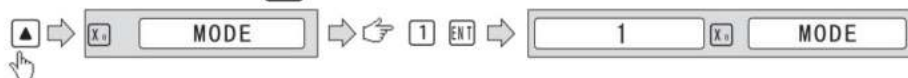

7. Continuously press **▼** to return EDM for machining. press **EDM** to quit the function;

### Example 1: positive direction machining ;

Machining is shown as the model chamber as follows

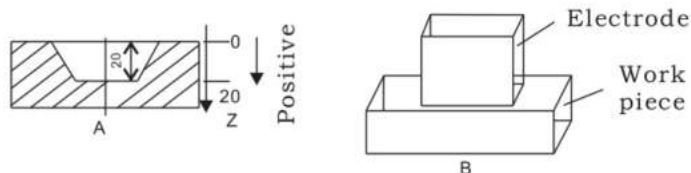

#### STEPS:

1、Touch one side of the workpiece with the TOOL, then press **Z0** , zero the Z axis.



2、 Press **EDM** , Setting DEPTH for 20.000; press **▼** to EDM for machining;



3、 Starting machining.

## EDM

Machining depth target value	<input type="text" value="20.000"/>	<input type="button" value="X0"/>	<input type="button" value="EDM RUN"/>
Value has been to be depth	<input type="text" value="0.000"/>	<input type="button" value="Y0"/>	
Self-position real time value	<input type="text" value="0.000"/>	<input type="button" value="Z0"/>	

**Example 2: Negative direction machining**

Machining is shown as the model chamber as follows

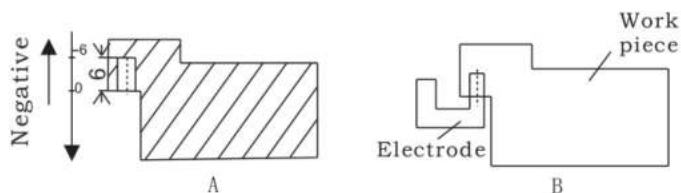

- 1、Touch one side of the workpiece with the TOOL, then press  , zero the Z axis.

<input type="text" value="1000.000"/>	<input type="button" value="Z0"/>	<input type="button" value="↔"/>	<input type="button" value="Z0"/>	<input type="button" value="↔"/>	<input type="text" value="0.000"/>	<input type="button" value="Z0"/>
---------------------------------------	-----------------------------------	----------------------------------	-----------------------------------	----------------------------------	------------------------------------	-----------------------------------

- 2、Press  , Setting DEPTH for -20.000; press  to EDM for machining;

<input type="button" value="EDM"/>	<input type="button" value="→"/>	<input type="button" value="X0"/>	<input type="text" value="DEPTH"/>	<input type="button" value="↔"/>	<input type="button" value="±"/>	<input type="text" value="20"/>	<input type="button" value="ENT"/>	<input type="button" value="→"/>	<input type="text" value="-20.000"/>	<input type="button" value="X0"/>	<input type="text" value="DEPTH"/>
------------------------------------	----------------------------------	-----------------------------------	------------------------------------	----------------------------------	----------------------------------	---------------------------------	------------------------------------	----------------------------------	--------------------------------------	-----------------------------------	------------------------------------

- 3、Starting machining.

Machining depth target value	<input type="text" value="20.000"/>	<input type="button" value="X0"/>	<input type="button" value="EDM RUN"/>
Value has been to be depth	<input type="text" value="0.000"/>	<input type="button" value="Y0"/>	
Self-position real time value	<input type="text" value="0.000"/>	<input type="button" value="Z0"/>	

**Example 3: PCD Function for EDM**

PCD Function can access the EDM Function . The operator enters PCD Function to input parameters for PCD and enter PCD machining state. At every position for machining, press the key  to access the EDM Function .



Bij het invoeren van de EDM-functie kan de operator de parameters invoeren voor EDM .

De bedieningsprocedure is als volgt:

1) PCD-parameters instellen (de instelling is hetzelfde als de algemene instelling van PCD)

Nadat u alle parameters hebt ingevoerd en de PCD-bewerkingsstatus hebt ingevoerd . De positie van het eerste gat wordt weergegeven.

2) Druk op  om de EDM-functieparameter in te voeren (de instelmethode is dezelfde als de algemene instelling van EDM Parameter); na invoer van alle

parameters, drukt u op  om de EDM-bewerkingsstatus in te voeren. Na invoer van alle parameters, drukt u op  om de EDM-functie te verlaten en de EDM-bewerkingsstatus .

3) Druk in de PCD-bewerkingsstatus op  voor de positie van het volgende gat, OVE de machine naar de displaywaarde 0 , dan drukt u op  om toegang te krijgen

EDM-functie opnieuw . 4)

Herhaal stap 2 en stap 3 voor de volgende bewerkingspunten.

## Calculator

### 7 rekenmachine

De rekenmachine biedt niet alleen normale wiskundige berekeningen zoals +, - ,  $\times$  , / , het biedt ook trigonometrie op metrische berekeningen zoals AS

ZONDE , Boog ZONDE , COS , Boog COS , BRUINEN , Boog TAN SQRT enz.

De bediening is hetzelfde als bij commerciële rekenmachines: eenvoudig te gebruiken.

**Functie rekenmachine invoeren en verlaten**

in normale weergavestand: druk op R om de rekenmachinefunctie te openen.

in de weergavestand van de rekenmachine: druk op R om de rekenmachinefunctie te verlaten.

Overdracht van de rekenmachineResultaten van geselecteerde zx is.

Nadat de berekening is voltooid, als de weergavemodus van de rekenmachine is ingesteld op **modus 1** , gebruiker kan:

druk op  $X_0$  om het berekende resultaat naar de x-as over te brengen; dan de x het venster zal deze waarde weergeven;

pers  $Y_0$  om het berekende resultaat speelgoedas over te brengen; dan venster zal deze waarde weergeven;

druk op  $Z_0$  om het berekende resultaat over te brengen naar de z-as; dan de z het venster zal deze waarde weergeven;

**De huidige weergegeven waarde in het venster overbrengen naar de rekenmachine.**

als de rekenmachine de weergavemodus voor **modus 1** heeft ingesteld , gebruiker kan:

pers  $X$  om de weergegeven waarde in het x-venster over te brengen naar de rekenmachine;

pers  $Y$  om de weergegeven waarde in het Y-venster over te brengen om r te berekenen;

pers  $Z$  om de weergegeven waarde in het z-venster over te brengen naar de rekenmachine;

## Appendix

## 8 Appendix

## 1. Troubleshooting:

The following are the preliminary solvents for troubleshooting.

If there is still trouble, Please contact out company or agents for help.

Troubles	Possible reasons	Solvents
No display	<ol style="list-style-type: none"> <li>1. Power isn't connected</li> <li>2. Power switch is off.</li> <li>3. The range of power voltage is not right.</li> <li>4. The inner power of Linear Scale is short.</li> </ol>	<ol style="list-style-type: none"> <li>1. Check power wire and connect the power</li> <li>2. Turn on the power switch.</li> <li>3. The range of voltage is in 80--260V</li> <li>4. Unplug the connector of linear scale</li> </ol>
One axis is not counting	<ol style="list-style-type: none"> <li>1. Replace the linear scale of the other axis.</li> <li>2. DRO is in special function</li> </ol>	<ol style="list-style-type: none"> <li>1. If count is normal, the linear scale has trouble; If abnormal, the DRO readouts has trouble.</li> <li>2. Quit the special function.</li> </ol>
Linear scale is not counting	<ol style="list-style-type: none"> <li>1. Reading head is bad for using range exceeds.</li> <li>2. Aluminum chips is in reading head of linear scale.</li> <li>3. The span between the reading head and metal part of linear scale is large.</li> <li>4. The metal parts of linear scale is damage.</li> </ol>	<ol style="list-style-type: none"> <li>1. Repair the linear scale</li> <li>2. Repair the linear scale</li> <li>3. Repair the linear scale</li> <li>4. Repair the linear scale</li> </ol>
Counting is error	<ol style="list-style-type: none"> <li>1. Shell is poor grounding.</li> <li>2. Low precision of machine.</li> <li>3. Speed of machine is too rapid.</li> <li>4. Precision of linear scale is low.</li> <li>5. The resolution of DRO readouts and the linear scale is not match.</li> <li>6. The unit (mm/inch) is not match.</li> <li>7. Setting the linear compensating is not arrest.</li> <li>8. Reading head of the linear scale is damaged.</li> </ol>	<ol style="list-style-type: none"> <li>1. Shell is good grounding.</li> <li>2. Repair the machine.</li> <li>3. Reduce the speed of machine.</li> <li>4. Mount the linear scale again.</li> <li>5. Set the resolution of the DRO again.</li> <li>6. Cover the unit of display mm/inch.</li> <li>7. Reset the linear compensation.</li> <li>8. Repair the linear scale.</li> </ol>
The counting of the linear scale is not accurate	<ol style="list-style-type: none"> <li>1. The mounting of linear scale does not demand the requirement, and the prcision is not adequate.</li> <li>2. The screw is loosen.</li> <li>3. Precision of machine is low.</li> <li>4. The resolution of digital readouts and the linear scale is not match.</li> </ol>	<ol style="list-style-type: none"> <li>1. Mount the linear scale again and level it.</li> <li>2. Lock all fixing screws.</li> <li>3. Repair the machine.</li> <li>4. Reset the resolution of digital readouts.</li> </ol>
Sometimes the linear scale is not counting	<ol style="list-style-type: none"> <li>1. The small car and steel ball is separated.</li> <li>2. The glass of reading head is wearied.</li> <li>3. The glass of reading head of the linear scale has dirt.</li> <li>4. The elasticity of the steel wire is not adequate.</li> </ol>	<ol style="list-style-type: none"> <li>1. Repair the linear scale.</li> <li>2. Repair the linear scale.</li> <li>3. Repair the linear scale.</li> <li>4. Repair the linear scale.</li> </ol>

## Appendix

### 2. Specifications of Digital Readout.

- 1) Supply Voltage range: AC 85 V ~ 230 V; 50 ~ 60 Hz
- 2) Power consumption: 15VA
- 3) Operating temperature: 0°C-- 50°C
- 4) Storage temperature: - 30°C-- 70°C
- 5) Relative humidity: < 90 % ( 25 )
- 6) Max Coordinate number: 3
- 7) Readout allowable input signal: TTL square wave
- 8) Allowable input signal frequency: < 5 M Hz
- 9) Max resolution of digital display length: 0.01  $\mu$ m
- 10) Max resolution of digital display angle: 0.0001 / PULSE

### 3. Instructions

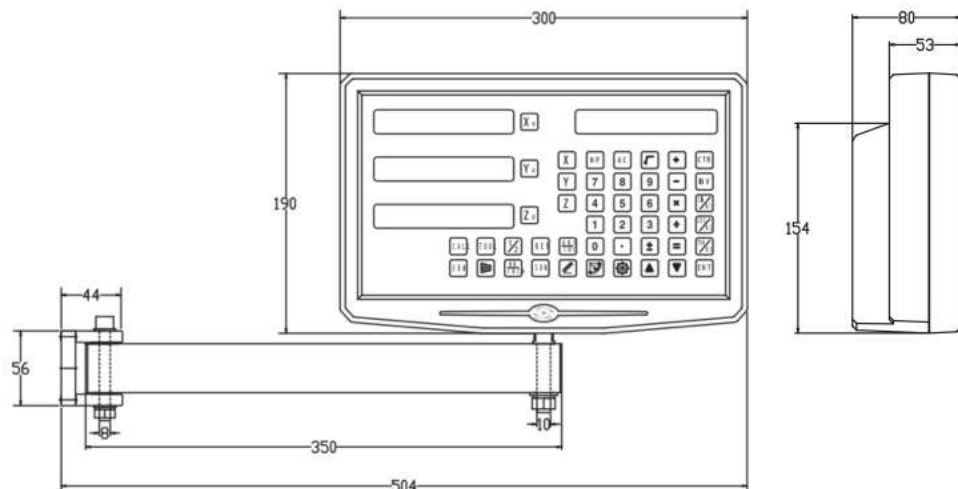

## 4. Examples of character output at the data interface

## 1、 X,Y,Z Axis

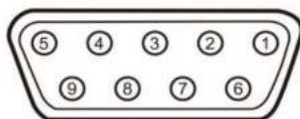

Pin	TTL (Standard)
1	
2	OV
3	
4	
5	
6	A+
7	5V
8	B+
9	R+

Pin	TTL (Standard)
1	5V
2	OV
3	A+
4	B+
5	R+
6	
7	
8	
9	

For your convenience,  
If you buy a digital readout,

The wiring definition of your linear scale must be the same as the 2 definitions in the above diagram to be universal!



## TTL signal Output:

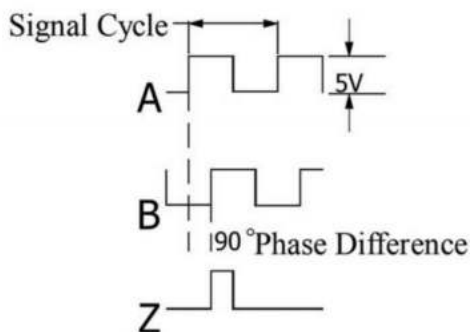

## EIA-422-A signal Output:

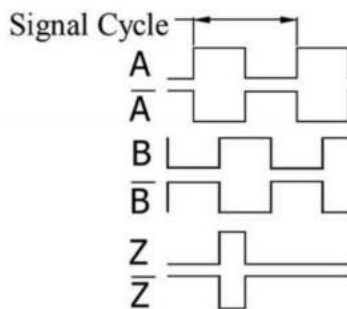

## 1. TECHNICAL PARAMETER

1.1 SCALING DISTANCE: 0.02 MM (50LINES /MM)

1.2 RESOLUTION: 5 $\mu$ M、1 $\mu$ M、0.5 $\mu$ M1.3 PRECISION:  $\pm 3\mu$ M、 $\pm 5\mu$ M、 $\pm 15\mu$ M/M (20 $\pm$ 0.1°C)

1.4 MEASURING RANGE: 30~3000MM

1.5 MOVING SPEED: HIGH-SPEED ENCODER 120 M/MIN (TO BE CUSTOMIZED)

ORDINARY ENCODER 60M/MIN

1.6 POWER SUPPLY: +5V $\pm$ 5%、80MA

1.7 CABLE LENGTH: STANDARD 3M (SPECIAL LENGTH AVAILABLE ACCORDING TO THE USER'S NEEDS)☑

1.8 WORKING TEMPERATURE: 0~45°C

1.9 PIN DESCRIPTION:

1) APPLICABLE TO: 9 PIN SOCKET EIA-422-A SIGNAL OUTPUT.

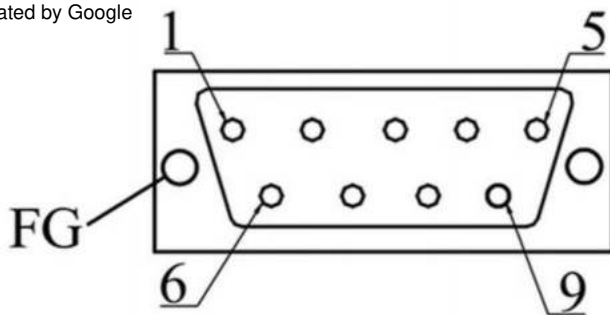

1) Applicable to: 9 pin socket EIA-422-A signal Output.

Pin Position	1	2	3	4	5	6	7	8	9
Signal	$\bar{A}$	$OV$	$\bar{B}$	Empty	$\bar{Z}$	$A$	+5V	$B$	$Z$
Color	Green Black	Black	Orange black	FG	White black	Green	Red	White	Orange

FG: Shield connected to metal casing.

1) Applicable to: 9 pin socket TTL signal Output.

Pin Position	1	2	3	4	5	6	7	8	9
Signal		$OV$		Empty		$A$	+5V	$B$	$Z$
Color		Black		FG		Green	Red	Orange	White

FG: Shield connected to metal casing.

# Lineaire schaal Installatietekeningen

# Installatiemethode:

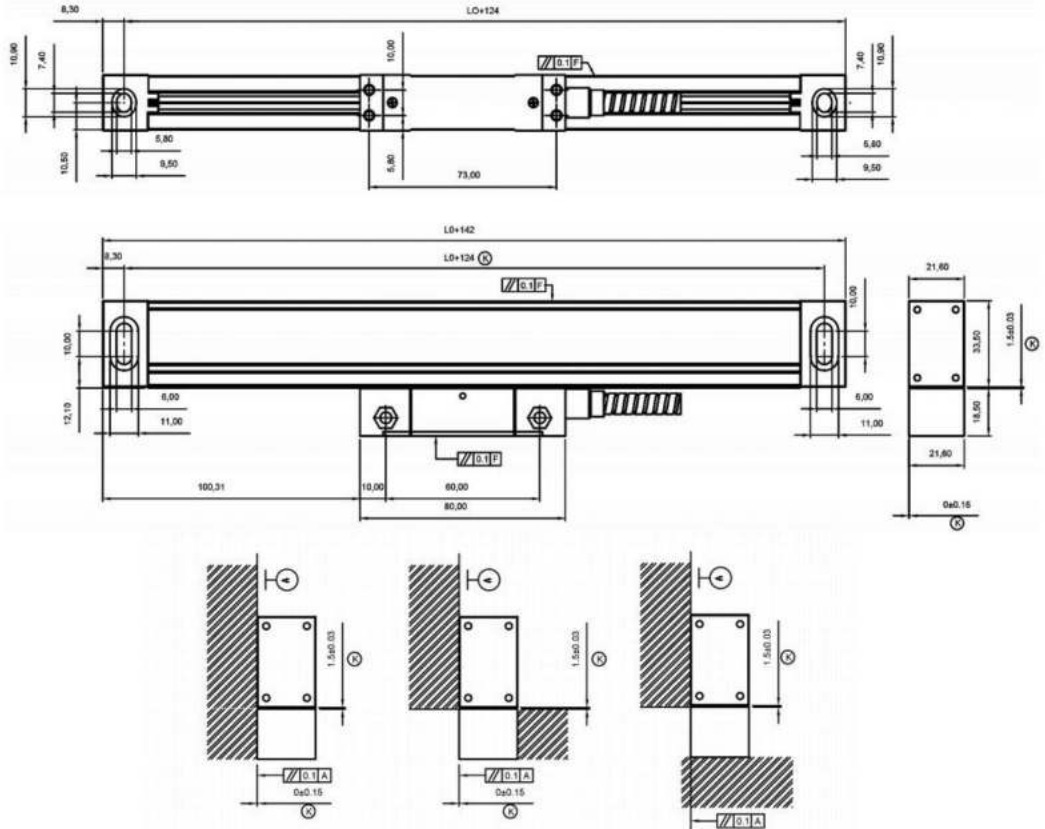

Standaardformaat: (Eenheid: mm)

Model	HET	L1	L2	Model	L0	L1	L2
JAAR-50	50	174	190	JAAR-550 550		674	690
JAAR-100	100	224	240	YE-600	600	724	740
JAAR-150	150	274	290	JA-650 650		774	790
JAAR-200 200		324	340	JAAR-700 700		824	840
JAAR-250 250		374	390	JIJ-750	750	874	890
JAAR-300 300		424	440	YE-800	800	924	940
JAAR-350 350		474	490	JAAR-850 850		974	990
JA-400 400		524	540	JAAR-900	900	1024	1040
JAAR-450 450		574	590	JAAR-950 950		1074	1090
JAAR-500 500		624	640	JAAR-1000 1000		1124	1140

L0: Effectieve meetlengte van de lineaire encoder; L1: Lengte van de lineaire encoder montagegaten; L2: Totale lengte lineaire encoder

## Onderhoud:

1. De effectieve slag van de lineaire encoder moet langer zijn dan de maximale slag. slag van de machinetool. Als de lengte niet voldoende is, vervang dan de lineaire encoder door een grotere slag of voeg een limietblok toe aan de machines. De eindpositie van de leeskop vanaf het einde van de lineaire encoderbehuizing moet niet minder dan 10 mm ruimte zijn (zie het volgende diagram).

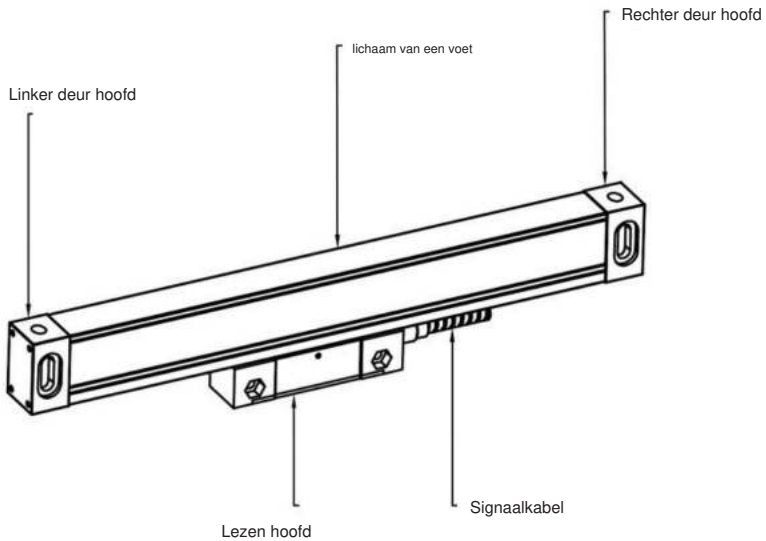

2. Voor elk niet-bewerkt oppervlak moet een vulstuk op de achterkant van de lineaire encoder worden geplaatst of moet een door de gebruiker gemaakte installatievulstuk worden gebruikt om de stabiliteit en betrouwbaarheid van de verbinding tussen de roosterliniaal en het montageoppervlak te garanderen.
3. Wanneer u een meetklok of een soortgelijk instrument gebruikt om de paralleliteit van de lineaire encoder te kalibreren, moet de hoek van de zijkop binnen  $\pm 30$  graden liggen. Hoe kleiner de hoek, hoe beter.

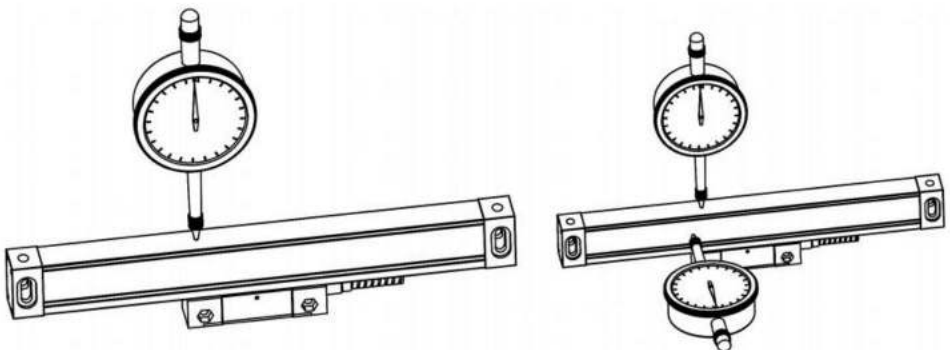

4. De installatiepositie van de lineaire encoder moet directe impact van ijzer vermijden  
vijsel, olie, water en stof (zoals weergegeven in de onderstaande afbeelding). De installatielengte  
van de L-plaat moet zo kort mogelijk zijn onder mogelijke omstandigheden, en  
Er moet rekening worden gehouden met de krachtsituatie van het montageoppervlak.

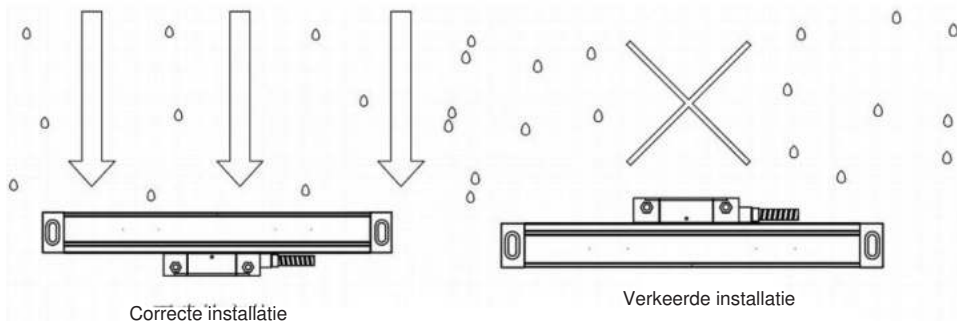

5. Er moet een opening van 0,5 mm of meer zijn tussen de stofkap en de liniaal  
lichaam, en vermijd contact tussen de stofkap en het liniaallichaam wanneer  
door de leeskop te verplaatsen (zoals hieronder).
6. Installatieschroefdraaddiepte, moet minimaal 6 tanden vergrendelingsdiepte hebben;  
kracht groter deel, zoals het ondersteunen van de digitale display meter plank vaste plaat, moet 8 tanden  
van vergrendeling diepte hebben; YE serie van schaal, de diepte van de draad  
diepte van de vergrendelingsdiepte. Zoals het ondersteunen van de digitale displaymeterplank vast  
plaat, moet meer dan 8 tanden vergrendelingsdiepte hebben; YE-serie schaal Met M4-schroeven  
geïnstalleerd montageoppervlak tikken na oppervlakte ontbramen, schilderen, beitsen verwijderen.  
(De volgende afbeelding)

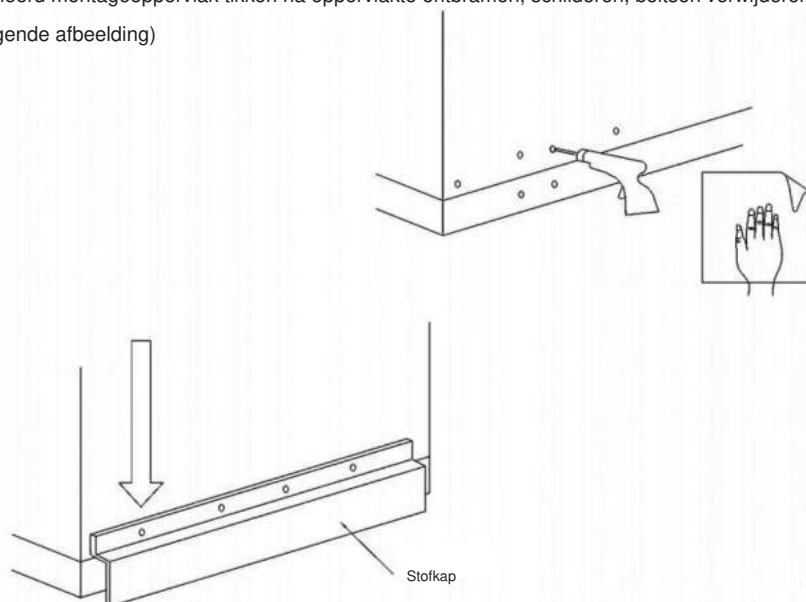

7. Bij het bevestigen van de signaallijn moet rekening worden gehouden met alle relevante bewegingsafstanden.  
De bevestigingspositie wordt zo ver mogelijk in het midden van de slag geplaatst en de overtollige signaallijn wordt met een kabelbinder vastgezet.
8. De aanpassing van het schaalhoogteniveau moet de lengte van het schaalcentrum zijn om de twee zijden van het symmetriepunt te nemen. Pas het referentiepunt aan, elke schaal, ongeacht de schoolniveaurichting of hoogterichting, het aanpassingsbereik: voor het schaallichaam, tot de kop van het schaallichaam op een afstand van niet meer dan 20 mm van elk uiteinde zal prevaleren. Voor de leeskop, tussen de twee vierhoekige referentieoppervlakken (de volgende afbeelding)

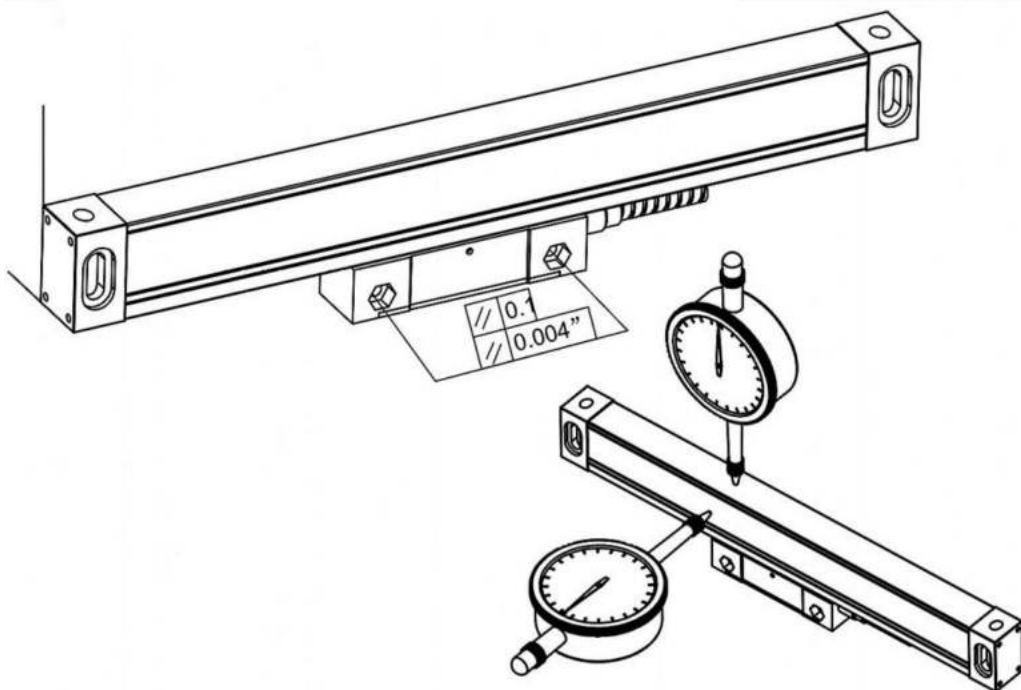

9. De buigradius van de signaallijn van de weegschaal is groter dan 60 mm.

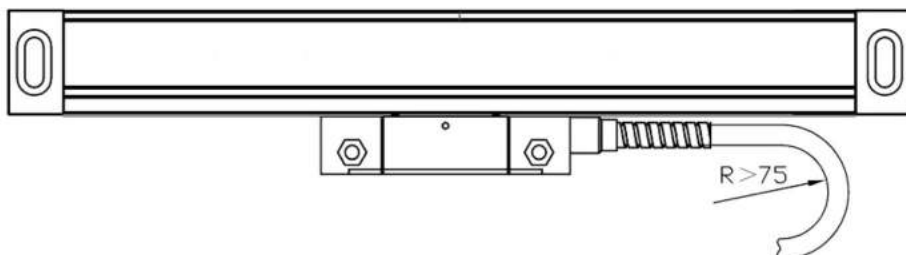

(1) Installatiebasisoppervlaktestandaard (Figuur 4.8abc drie installatiemethoden)

1. Het installatieoppervlak van het liniaallichaam is evenwijdig aan het installatieoppervlak van de leeskop en de parallelleiteit tussen de installatieoppervlakken is  $<0,1$  mm

2. Het installatieoppervlak van het liniaallichaam staat loodrecht op de installatieoppervlak van de leeskop, en de loodrechtetheit tussen de installatieoppervlakken is  $<0,1$  mm

2) Installatienormen voor het liniaallichaam (Figuur 4.9, Figuur 4.10)

1. Hoogterichting ten opzichte van de machinegeleider, parallelleiteit  $<0,1$  mm, maximaal niet meer dan  $0,15$  mm. Wat betreft het symmetriepunt geldt: hoe kleiner, hoe beter.

3) Standaard van leeskopinstallatie

1. De speling tussen de leeskop en de hoogterichting van het liniaallichaam bedraagt na installatie  $0,8$  mm -  $1,6$  mm en trek vervolgens het padblok terug (Figuur 4.11)

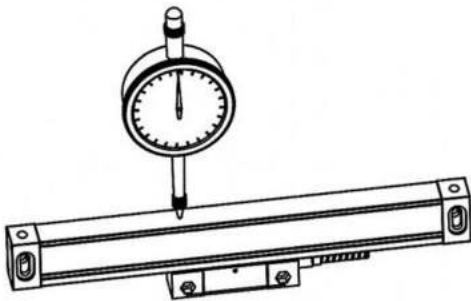

4.9

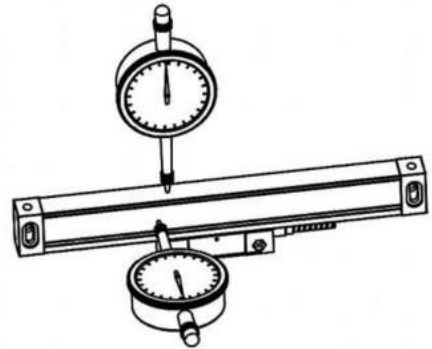

4.10

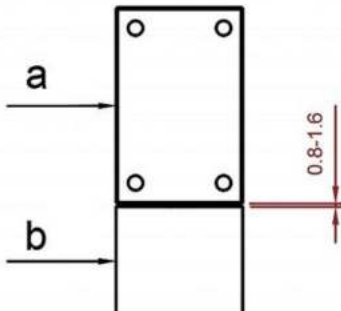

2. Lees de kop aan de A-kant en de liniaal aan de B-kant.  
Verkeerde uitlijning in horizontale richting.  
 $0,25 \pm 0,15$  mm

3. Parallelleiteit van de leeskop ten opzichte van  
machinereedschap  $<0,10$  mm, maximaal mag niet  
groter zijn dan  $0,30$  mm

**Parameter:**

<b>Model</b>	SNS-3V-YE102024	SNS-3V-YE161838
<b>Rated voltage:</b>	AC85-230V 50Hz/60Hz	
<b>Resolution</b>	5 $\mu$ m	
<b>Number of axes</b>	3	
<b>Range</b>	10 inches 20 inches 24 inches	16 inches 18 inches 38 inches

**Standaard accessoires:**

<b>Accessories for digital display meters:</b>	<b>Accessories for grating ruler:</b>
<ol style="list-style-type: none"> <li>1. Support rod * 1</li> <li>2. Knife holder plate * 1</li> <li>3. Transparent watch case * 1</li> <li>4. Power cord * 1</li> <li>5. Watch holder * 1</li> <li>6. Butterfly piece * 2</li> <li>7. M8 * 70 screw * 1</li> <li>8. M10 * 55 screw * 1</li> <li>9. Nut M10 * 1</li> <li>10. Nut M8 * 1</li> <li>11. Nut M5 * 1</li> <li>12. Internal hexagonal screw M5 * 20 * 2</li> <li>13. Internal hexagonal screw M5 * 25 * 1</li> <li>14. M4 * hex socket screw * 4</li> <li>15. M5 * 10 machine meter screws * 2</li> <li>16. Washer <math>\phi</math> 10 * 1</li> <li>17. Washer <math>\phi</math> 8 * 1</li> <li>18. Washer <math>\phi</math> 5 * 1</li> <li>19. Rubber washer 20 * 10 * 1 * 1</li> <li>20. Rubber washer 20 * 10 * 0.5 * 1</li> <li>21. Spring washer <math>\phi</math> 10 * 1</li> <li>22. Spring washer <math>\phi</math> 8 * 1</li> <li>23. Spring washer <math>\phi</math> 5 * 1</li> </ol>	<ol style="list-style-type: none"> <li>1. Ruler cover * 3</li> <li>2. L mounting plate * 4</li> <li>3. Plug * 6</li> <li>4. Screw pack * 3 bags</li> </ol> <p>Each bag contains:</p> <p>Internal hexagonal screw M4 * 30 * 4;  Internal hexagonal screw M4 * 12 * 2;  Internal hexagonal screw M4 * 8 * 4;  U-shaped gasket T=0.2mm * 2;  Washer <math>\phi</math> 6 * 2;  Washer <math>\phi</math> 5 * 2;  Washer <math>\phi</math> 4 * 6;  Line card * 2</p>

Dit apparaat voldoet aan Deel 15 van de FCC-regels. De werking is onderworpen aan de volgende twee voorwaarden: (1) Dit apparaat mag geen schadelijke interferentie veroorzaken, en (2) dit apparaat moet alle ontvangen interferentie accepteren, inclusief interferentie die ongewenste werking kan veroorzaken.

**Fabrikant:** Shanghai muxinmuyeyouxiangongsi

**Adres:** Shuangchenglu 803nong11hao1602A-1609shi, baoshanqu, shanghai  
200000 CN.

**Geïmporteerd naar AUS:** SIHAO PTY LTD, 1 ROKEVA STREET EASTWOOD NSW  
2122 Australië

**Geïmporteerd naar de VS:** Sanven Technology Ltd., Suite 250, 9166 Anaheim  
Place, Rancho Cucamonga, CA 91730



E-CrossStu GmbH  
Mainzer Landstr.69, 60329 Frankfurt am Main.



YH CONSULTING LIMITED.  
C/O YH Consulting Limited Kantoor 147, Centurion House,  
Londen Road, Staines-upon-Thames, Surrey, TW18 4AX

**VEVOR**®  
TOUGH TOOLS, HALF PRICE

Technische ondersteuning en e-garantiecertificaat  
[www.vevor.com/support](http://www.vevor.com/support)

# VEVOR<sup>®</sup>

## TOUGH TOOLS, HALF PRICE

Teknisk support och E-garanticertifikat

[www.vevor.se/support](http://www.vevor.se/support)

## DRO DISPLAY ANVÄNDARHANDBOK

MODELL: SNS-3V-YE102024 ÄR NS-3V-YE161838

vi fortsätter att vara engagerade i att ge dig verktyg till konkurrenskraftiga priser. "rädda hälften", "Halva priset" eller andra liknande uttryck som används av oss representerar endast en uppskattning av besparingar du kan dra nytta av att köpa vissa verktyg hos oss jämfört med de större toppmärken och betyder inte nödvändigtvis att täcka alla kategorier av verktyg som erbjuds av oss. Du påminns vänligen om att kontrollera noggrant när du gör en beställning hos oss om du gör det faktiskt spara hälften i jämförelse med de främsta stora varumärkena.

**VEVOR**<sup>®</sup>  
TOUGH TOOLS, HALF PRICE

DRO DISPLAY

MODELL: SNS-3V-YE102024 SNS-3V-YE161838



### BEHÖVER HJÄLP? KONTAKTA OSS!

Har du produktfrågor? Behöver du teknisk support? Du får gärna kontakta oss:

Teknisk support och E-garanticertifikat [Www.vevor.se/support](http://www.vevor.se/support)

Detta är den ursprungliga instruktionen, läs alla manualer noggrant innan användning. VEVOR reserverar sig för en tydlig tolkning av vår användarmanual. Produktens utseende ska vara beroende av produkt du fått. ursäkta oss att vi inte kommer att informera dig igen om det finns någon teknik eller mjukvaruuppdateringar på vår produkt.

Kära användare:

Tack för att du köpte digitala avläsningar i multifunktionsserien ·

Digitala avläsningar används i en mängd olika applikationer. Dessa inkluderar verktygsmaskiner , i foderyxor, mät- och inspektionsutrustning, EDM, och mätstationer för uppdelningsapparater, inställningsverktyg , produktionskontroll. För att uppfylla kraven i dessa applikationer kan många kodare anslutas till de digitala avläsningarna. Läs noga alla instruktionerna i bruksanvisningen före användning och följ dem strikt · spara manualen för framtida referenser ·

säkerhetsuppmärksamhet:

⌘ TILL Förhindra elektriska stötar eller brand, fukt eller direkt sprutning kylvätska måste undvikas. I händelse av rök eller konstigt luktar från den digitala avläsningen, dra ur nätkontakten omedelbart, annars kan brand eller elektriska stötar orsakas. I ett sådant fall, försök inte reparera det, kontakta företaget eller **distributors.**

⌘ Digital avläsning är en exakt måtenhet som används med en optik Linjär skala· när den används, om kopplingen mellan

Linjär skala och den digitala avläsningen är trasig eller skadad externt kan felaktiga mätvärden uppstå · Därför, användaren bör vara försiktig.

⌘ Försök inte att reparera eller modifiera den digitala avläsningen, annars kan fel, fel eller skada kan uppstå. I händelse av något onormalt tillstånd, vänligen kontakta företaget eller distributören.

⌘ Om den optiska linjära vågen som används med den digitala avläsningen är skadad, använd inte en linjär väg av annat märke · Eftersom prestanda, specifikation och anslutning av produkter från olika och CAn

inte anslutas utan instruktion av specialiserad teknik personal, annars uppstår problem med den digitala avläsningen.

⌘ **With the continuous updating of products, if there are changes or** ändringar av urvalsparametrarna ska de slumpmässiga filerna ha företräde och företaget har den slutliga tolkningsrätten utan förvarning.

## Contents

---

1.	Illustration of Panel and keyboard .....	4
2.	Caption of the keyboard .....	5
3.	Parameters settings .....	7
3.1	Parameters setup routine entrance .....	7
3.2	Parameters Settings Description .....	7
3.2.1	Setting the Resolution .....	7
3.2.2	Setting Positive Direction for Counter .....	8
3.2.3	Toggle Between R/D Display Mode .....	8
3.2.4	Setting Z axis Dial .....	8
3.2.5	Setting the Rotary Radius of the Workpiece.....	9
3.2.6	Setting the Angle Display Mode .....	9
3.2.7	Setting the Baudrate of RS_232(optional) .....	9
3.2.8	Setting the Absolute Zeroing enable or disable .....	10
3.2.9	Setting the Absolute form the Special Function .....	10
3.2.10	Setting the Calculator display Mode.....	10
3.2.11	display brightness setting .....	10
3.2.12	The linear scale counting frequency setting .....	11
3.2.13	Setting QUIT .....	11
3.2.14	Setting the type of the DRO. ....	11
3.2.15	Signal Interface Type .....	11
3.2.16	Restore Factory Settings: .....	12
3.2.17	Shrinkage Ratio enable or disable.....	12
3.2.18	Setting Compensation Type .....	12
3.2.19	Inch display, set the number of digits after the decimal point...	13
3.2.20	Setting EDM(optional) .....	13
3.2.21	Setting Linearity Compensation. ....	13
3.2.22	Setting the Shrinkage Ratio .....	13
4.	General Operations .....	14
4.1	Zeroing.....	14
4.2	Preset Data to Designated Axis .....	14
4.3	Toggle Display Unit between inch and mm .....	14
4.4	Absolute/Incremental/200 groups SDM .....	15
4.5	1/2 Function .....	15
4.6	Clear All SDM Datum.....	16

## Contents

---

4.7 Sleeping Mode .....	16
4.8 Power Interruption Memory .....	16
4.9 Search the Absolute Reference Point of Scale .....	17
4.10 Non Linear Error Compensation .....	20
5、200 Groups SDM coordinate .....	21
5.1 Zeroing at the Current Point.....	21
5.2 Preset datum of SDM coordinate .....	22
6、Special Function.....	24
6.1 Circumference Holes Processing .....	25
6.2 Linear Holes Processing .....	28
6.3 ARC Processing .....	30
6.4 Oblique Processing .....	39
6.5 Slope Processng.....	43
6.6 Chamber Processing.....	44
6.7 The Tool Diameter Compensation Function .....	45
6.8 Digital Filter of the Grinding Machine .....	46
6.9 Lathe Function .....	47
6.9.1 200 sets TOOL Libs .....	47
6.9.2 Taper Function .....	48
6.9.3 R/D Function .....	49
6.9.4 Y + Z Function ( only applicable to : 3 axes Lathe).....	49
6.10 EDM.....	50
7、Calculator.....	56
8、Appendix .....	57

## Illustration of Panel and keyboard

## THREE AXIS PANEL

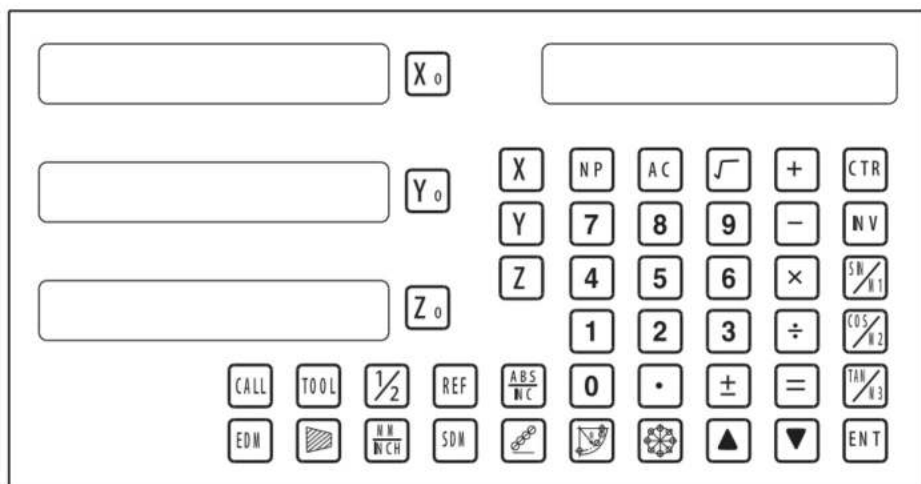



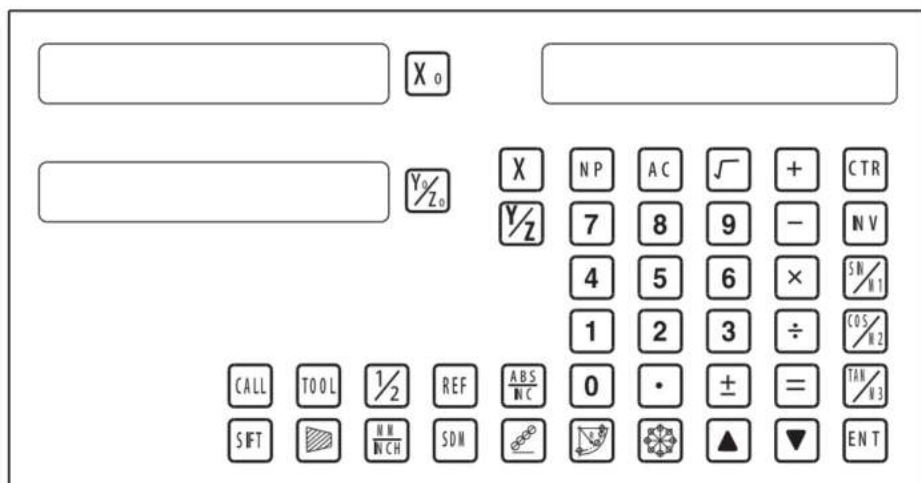









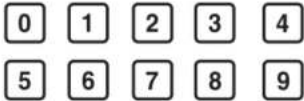



## TWO AXIS PANEL















## Caption of the keyboard

## Keyboard Description

	Keys for axis selection
	Zero select axis
	Enter +/- sign
	Enter decimal point
	Entry keys for numbers
	Operation key (in Calculation function key)
	Enter or quit calculating state
	Cancel incorrect operation
	Calculate inverse trigonometric
	Square root
	Confirm operation
	Toggles between inch and millimeter units.
	Press when ready to identify a reference mark.
	Function keys for 200 sub datum
	ARC cutting function
	holes displayed equally on a circle
	holes displayed equally on a line

## Caption of the keyboard



	Calculate trigonometric or Slope Processing function key
	Calculate trigonometric or rectangular inner chamber processing function key
	Calculate trigonometric or the tool diameter compensation function key
	Toggle between ABS/INC coordinate
	Stroll up or down to select
	Taper measured function key
	Tool library call key
	Opens the tool table.( lathe)
	EDM function key
	Filter display function key
	Half a display value of an axis
	Non Linear Error Compensation function keys





## Parameters settings

---

### 3. Parameters settings

#### 3.1 Parameters setup routine entrance.

Press  to enter initial system and self-check after DRO powers on in 1 second, then Parameters settings display in the Parameters window. Press   to select the item you want to change.

If you want to quit initial setting, press   until "QUIT" appears in message window and press . You can also press  to quit initial setting.

#### 3.2 Parameters Settings Description



##### 3.2.1 Setting the Resolution

Press   until "RESOLUTE" appears in message window;

When selecting the LINEAR encode, the resolution will be set as follow:

There are 19 types of resolution:

0.01um;0.02um;0.05um;0.10um;0.20um;0.25um;0.50um;1.00um;  
2.00um;2.50um;5.00um;10.00um;20.00um;25.00um;50.00um;  
100.00um;200.00um;250.00um;500.00um.

Press  to change the resolution for X axis; Press  to change the resolution for Y axis; Press  to change the resolution for Z axis;

Set the resolution 5.00um to 1.00um for X axis:

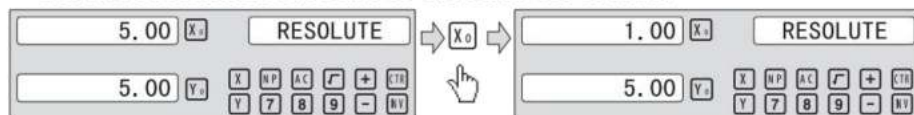

When selecting the rotary encode, the resolution will be set as follow:

Input the rotary encode parameter value .

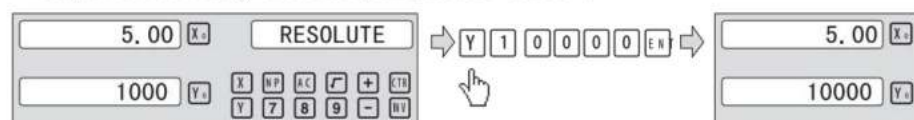

## Parameters settings

## 3.2.2 Setting Positive Direction for Counter

Press  $\blacktriangle$   $\blacktriangledown$  until “DIRECTE” appears in message window.

Direction ‘0’ means the display value will increase when scale moves from right to left and decrease when scale moves from left to right. Direction ‘1’ means the display value will increase when scale moves from left to right and decrease when scale moves from right to left.

Press  $X_0$  to change the Direction for X axis; Press  $Y_0$  to change the Direction for Y axis; Press  $Z_0$  to change the Direction for Z axis; as follow:

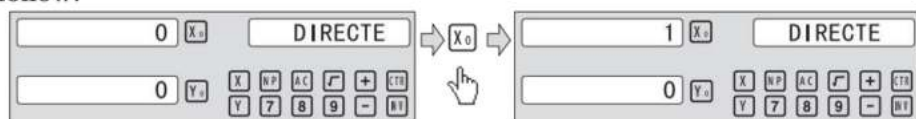

## 3.2.3 Toggle Between R/D Display Mode

Press  $\blacktriangle$   $\blacktriangledown$  until “R OR D” appears in message window. X window, Y window, Z window displays ‘0’ or ‘1’ separately.

‘0’ is mode R, which means the display value equals the actual measurement. ‘1’ is mode D where the display value equals the double actual measurement. Press  $X_0$  to change the R/D for X axis; Press  $Y_0$  to change the R/D for Y axis; Press  $Z_0$  to change the R/D for Z axis; as follow:

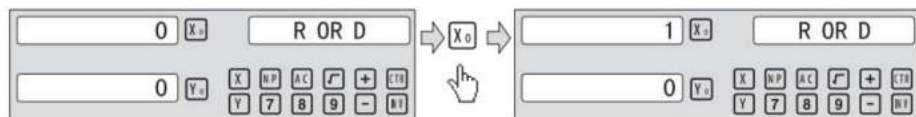

## 3.2.4 Setting Z axis Dial

Press  $\blacktriangle$   $\blacktriangledown$  until “Z DIAL” appears in message window.

Z axis dial should be set if Z axis is emulated for 2 axis milling and only install linear scale for X,Y axis. Z axis dial means the distance the Z axis travels when screw runs a revolution.

## Parameters settings

Set the Z axis Dial 2.5mm as follow ;



### 3.2.5 Setting the Rotary Radius of the Workpiece

Press **▲** **▼** until “RDIUS” appears in message window.

The Rotary radius type is used perimeter to measure angle.

Input the Rotary Radius parameter value 2000mm as follow:

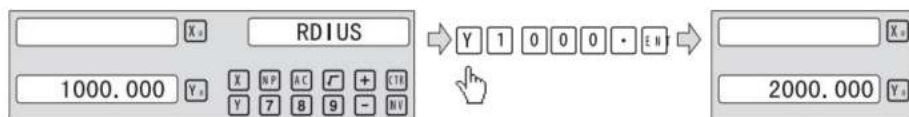

### 3.2.6 Setting the Angle Display Mode

Press **▲** **▼** until “ANG DISP” appears in message window.

Press **X0** to change the angle display mode for X axis; Press **Y0** to change the angle display mode for Y axis; Press **Z0** to change the angle display mode for Z axis; Example for X axis:

“0.0000” means the angle mode is Circulating DD;

“0000.0000” means the angle mode is Incremental DD;

“0.00.00” means the angle mode is Circulating DMS;

“0000.00.00” means the angle mode is Incremental DMS;

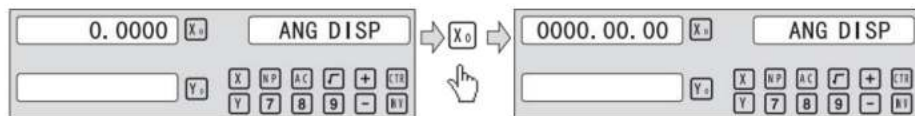

### 3.2.7 Setting the Baudrate of RS\_232 (Special customization function, if you need to buy, please contact the dealer to customize)

Press **▲** **▼** until “BAUDRATE” appears in message window.

Set the Baudrate 115200 as follow ;

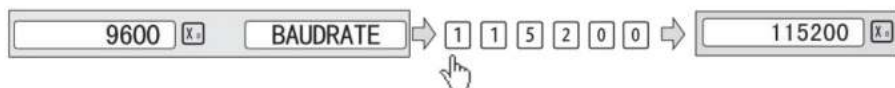

## 3.2.8 aktivera eller inaktivera absolut nollställning

trycka   tills "ABS NOLL" visas i meddelandefönstret.

de betyder att ABS-nollställning och förinställda data kommer att vara aktivera i normalt displayläge.

'1' betyder att ABS-nollställning och förinställda data kommer att vara inaktivera i normalt displayläge.

tryck för  för att ändra det absoluta nollställningsläget för axelaxeln, tryck på

 att ändra absolut nollställningsläge för Y-axeln, tryck  till

ändra det absoluta nollställningsläget för Z-axeln; Exempel för x-axeln.

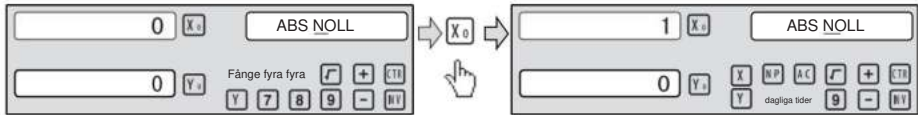

## 3.2.9 ställa in Absolut från specialfunktionen

trycka   tills "ABS ASST" visas i meddelandefönstret.

'0' betyder att endast specialfunktionspositionsvärde visas i specialfunktion drift.

'1' betyder specialfunktionspositionsvärde + ABS Positionsvärdet är visas i den speciella funktionsfunktionen.

trycka  för att ändra det absoluta läget för specialfunktionen

ställas in enligt följande:

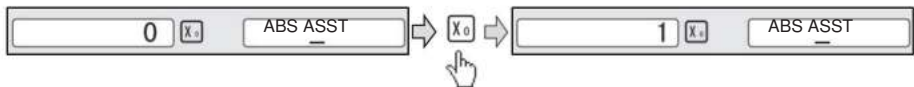

## 3.2.10 ställa in Calculator visningsläge

trycka   tills "UCCTR MODE" visas i meddelandet W . indow

de disply;

'1' visningsvärde vid meddelandefönstret i displayen;

trycka  för att ändra räknarens visningsläge ställs in AS follow;

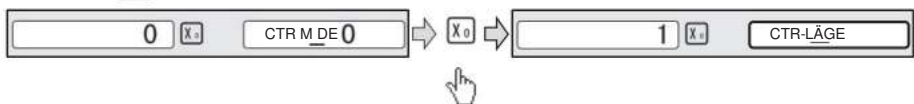

## 3.2.11 inställning av displayens ljusstyrka

LED-skärmens ljusstyrka, fabriksinställningen är endast "3", ju högre parameter, desto ljusare ljusstyrka. tryck "x0" för att set, det rekommenderas inte att du ställer in standardvärdet själv.

## Parameters settings

---

### 3.2.12 The linear scale counting frequency setting

The factory default setting is only "12", the higher the parameter, the lower the counting frequency, press "X0" to set, it is not recommended that you set the default value yourself.

### 3.2.13 Setting QUIT: Digital display table parameters quit button.

### 3.2.14 Setting the type of the DRO.

The type of the DRO will be display on the right window. then press the key **ENT** to select the correct type. the following system item will be set:

“MILL-3” means the DRO type is 3-axis milling machine table;

“MILL-2” means the DRO type is 2-axis milling machine table;

“LATHE-2” means the DRO type is 2-axis lathe table;

“LATHE-3” means the DRO type is 3-axis lathe table;

“GRIND” means the DRO type is Grind table;

“EDM” means the DRO type is EDM table; (Special customization function, if you need to buy, please contact the dealer to customize)

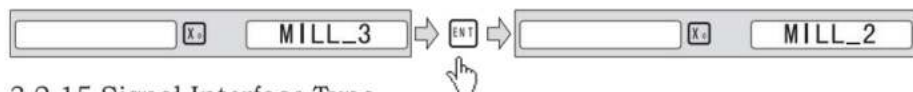

### 3.2.15 Signal Interface Type

Message window displays “SEL AXIS” which indicates the step is to Sensor input signal mode. Press **X0** to change the signal mode for X axis; Press **Y0** to change the signal mode for Y axis; Press **Z0** to change the signal mode for Z axis; Example for X axis:

Press **X0** to scroll through the Rotary encode type, the Linear encode type, the Rotary rdius type.

X window displays the Signal type.

“LInER” means the Signal type is linear encode type ;

“EnCoDE” means the Signal type is Rotary encode type;

“RdIUS” means the Signal type is Rotary rdius type ;

Example: currently in the linear encode type, to toggle to the Rotary encode type;

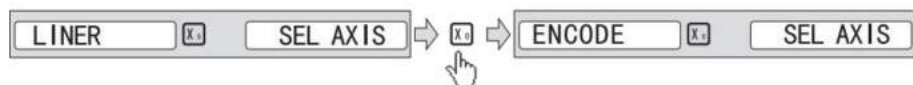

## Parameters settings

## 3.2.16 Restore Factory Settings:

Clear all data except DRO type. DRO will load default setup for parameter. After loading default setup, user must search RI once to enable resuming ABS datum function; otherwise to resume the datum by RI is unable;

Message window displays “ALL CLR”, press **ENT** and message windows display “PASSWORD” indicating the operator to input password; Press 2000 + **ENT** in turn to load default value;

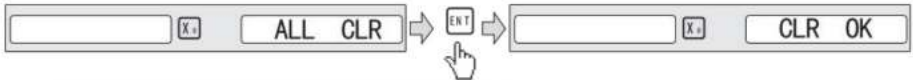

## 3.2.17 Shrinkage Ratio enable or disable.

Message window displays “SRK OFF” to disable Shrinkage rate function. Press **ENT** to enable Shrinkage rate function in Message window displays “SRK ON” :

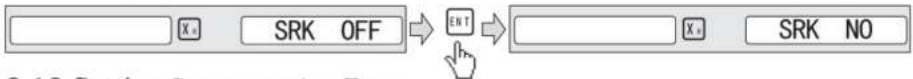

## 3.2.18 Setting Compensation Type

Message window displays “SEL COMP” which indicates the step is to compensation type. Press **X0** to change the compensation type for X axis; Press **Y0** to change the compensation type for Y axis; Press **Z0** to change the compensation type for Z axis; Example for X axis:

Press **X0** to scroll through the not compensation type, the Linear compensation type, the non-linear compensation type.

“no-CO” means the compensation type is not compensation type;

“LinE-CO” means the compensation type is linear compensation type.

“non-LinE” means the compensation type is non-linear linear compensation type;

Example for X axis: currently in the not compensation type, to toggle to the linear compensation type;

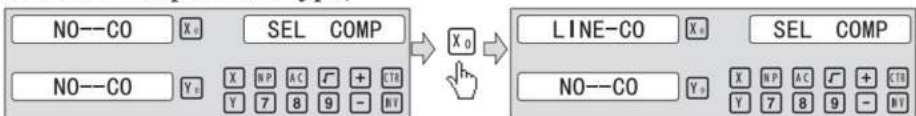

## Parameters settings

## 3.2.19 Inch display, set the number of digits after the decimal point

In the inch display mode, the number of digits after the decimal point is set, the factory default digit is "4", press "X0" to set, can be set according to actual needs.

3.2.20 Setting EDM: it is not recommended that you set the default value yourself, EDM function, Set the relay off on time.

## 3.2.21 Setting Linearity Compensation.

Message window displays "LIN COMP" which indicates the step is to Linearity Compensation. Compensate the linear error to make display value equals to standard value.

The calculation of compensation rectifying coefficient:

$$\text{Coefficient} = \frac{(\text{Measurement} - \text{Standard value}) \times 1000.000}{\text{Standard value}}$$

Example for X axis:

Measurement 200.020mm

Standard value 200.000mm

Rectifying coefficient= (200.020-200) \* 1000 /200 =-0.01mm/m

Input compensation rectifying coefficient 0.01 as follow:

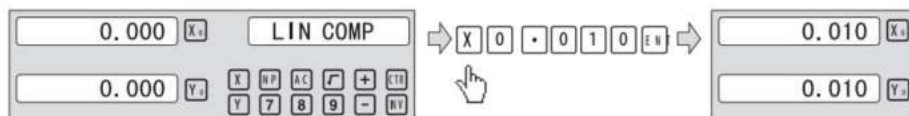

## 3.2.22 Setting the Shrinkage Ratio

Press until "SHRINK" appears in message window;

$$\text{Shrinkage ratio} = \frac{\text{Dimensions of the finished product}}{\text{Dimensions of the working piece}}$$

Set the shrinkage ratio 1.005 as follow;

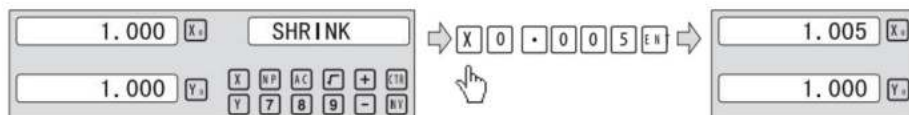



## General Operations

---

### 4、 General Operations;

#### 4.1 Zeroing



Zero the designated axis in normal display state. Zeroing is used to set the current position as datum point as follow;

key		$X_0$	$\Rightarrow$	X axis zero	<table style="width: 100%; border-collapse: collapse;"> <tr> <td style="border: 1px solid gray; padding: 2px;">0.000</td> <td style="border: 1px solid gray; padding: 2px;"><math>X_0</math></td> </tr> <tr> <td style="border: 1px solid gray; padding: 2px;">0.000</td> <td style="border: 1px solid gray; padding: 2px;"><math>Y_0</math></td> </tr> <tr> <td style="border: 1px solid gray; padding: 2px;">0.000</td> <td style="border: 1px solid gray; padding: 2px;"><math>Z_0</math></td> </tr> </table>	0.000	$X_0$	0.000	$Y_0$	0.000	$Z_0$
0.000	$X_0$										
0.000	$Y_0$										
0.000	$Z_0$										
key		$Y_0$	$\Rightarrow$	Y axis zero							
key		$Z_0$	$\Rightarrow$	Z axis zero							

$X_0$  or  $Y_0$  or  $Z_0$  will be return to the original data before the reset.

#### 4.2 Preset Data to Designated Axis



Preset a value to current position for a designated axis in normal display state.

25.400	$X_0$	$\Rightarrow$		X	1	8	0	.	0	1	0	ENT	$\Rightarrow$	180.010	$X_0$
50.800	$Y_0$	$\Rightarrow$		Y	5	8	6	.	0	1	0	ENT	$\Rightarrow$	586.010	$Y_0$
76.200	$Z_0$	$\Rightarrow$		Z	8	8	8	.	6	6	0	ENT	$\Rightarrow$	888.660	$Z_0$



#### 4.3 Toggle Display Unit between inch and mm

Length can be displayed either in “mm” (metric) or “inch” (imperial). Display unit can be toggled between mm and inch.

Example: Display value toggle from mm to inch;

25.400	$X_0$	$\Rightarrow$	mm	$\Rightarrow$		$\Rightarrow$	inch	1.0000	$X_0$
50.800	$Y_0$							2.0000	$Y_0$
76.200	$Z_0$				3.0000			$Z_0$	

Example: Display value toggle from inch to mm;

1.0000	$X_0$	$\Rightarrow$	inch	$\Rightarrow$		$\Rightarrow$	mm	25.400	$X_0$
2.0000	$Y_0$							50.800	$Y_0$
3.0000	$Z_0$				76.200			$Z_0$	

## General Operations

### 4.4 Absolute/Incremental/200 groups SDM

**Function:** The DRO has 3 coordinate display modes: the absolute mode (ABS); the incremental mode (INC) and 200 groups Second Data Memory (SDM) with the range of 00 to 99. Zero point of work-piece is set at the origin point of ABS coordinate. The relative distance between datum of ABS and SDM remains unchanged when ABS datum is changed.

1. Toggle from ABS to INC coordinate;

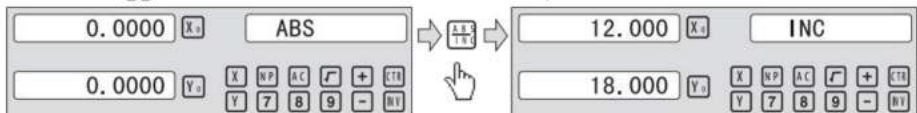

2. Toggle from INC to ABS coordinate;

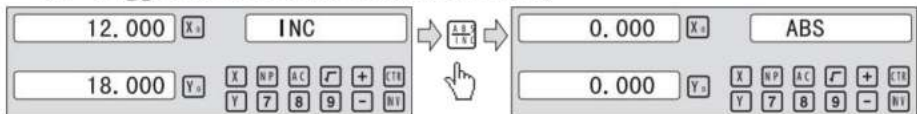

3. Toggle from SMD to ABS coordinate;

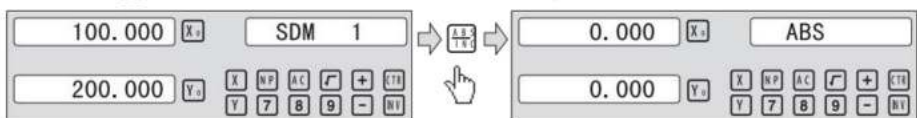

### 4.5 1/2 Function

**Function:** Set the center of work piece as datum by halving the displayed value.

**Example:** Set the center of rectangle as datum as the right figure.

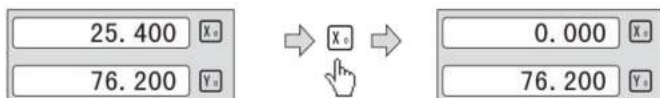
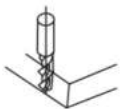

**Steps:**

1. Touch one side of the workpiece with the TOOL, then zero the X axis.



## Allmän verksamhet

2. Ta VERKTYGET till motsatt sida av arbetsstycket och rör vid det.

Tryck sedan på  +  i sin tur för att värdera X-axelns visningsvärde.

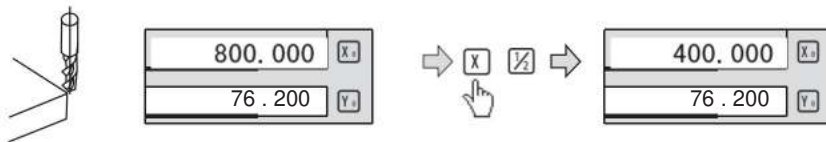

3. Flytta bearbetningstabellen tills "0.000" visas i x-axeln  
fönster. Positionen är arbetsstyckets centrum.



4. 6 radera alla SDM-datum.

I ABS-läge, för att kontinuerligt trycka på  tio gånger kommer att orsaka att rensa  
alla datum för 200 uppsättningar SDM. Message-fönstret visar USDM  
CLR".

4. 7 sovläge

i inte ABS-läge, tryck på knappen  KAN stänga av all display

och DRO:n går in i viloläget och trycker sedan på denna tangent  
igen kommer DRO att återgå till arbetsläget. I den sovande  
Läge DRO är fortfarande i arbetsläge och registrerar faktiskt VERKTYGET  
**movement.**

Exempel: I inte ABS-läge, för att komma åt sleepin8-läget genom att trycka på  
nyckeln F.  läge, tryck på knappen F för att avsluta   
sovläge.

4. 8 strömavbrottsminne.

Minnet används för att lagra inställningarna för DRO och maskinen  
referensvärden när POWER är avstängd.

## 4.9 Sök i skalans A bsoutreferenspunkt

Under den dagliga bearbetningsprocessen är det mycket vanligt att bearbetning kan inte slutföras inom ett arbetsskift, och därmed DRO måste stängas av efter arbetet, eller strömbrott inträffar under bearbetningsprocessen som leder till förlorat arbetsstyckesdatum (arbetsstyckets nollposition), återställande av arbetsstyckets nollpunkt att använda kantsökare eller annan metod är oundvikligen inducera högre bearbetning med noggrannhet eftersom det inte är möjligt att återupprätta arbetsstyckets utgångspunkt exakt vid föregående position återställning av arbetsstyckets datum vry exakt och inget behov av att återställa arbetsstyckets datum med hjälp av kantavkännare eller andra metoder, varje linjär skala har en refpoint position som är utrustad med ref position för att tillhandahålla referenspunktsminnesfunktion.

Arbetsprincipen för referensdatumminnesfunktionen är som följer.

eftersom refpunkten för linjär skala är permanent och fixerad kommer den att göra det ändras eller försvinner aldrig när DRO-systemet är avstängt. Därför behöver vi helt enkelt lagra avståndet mellan refpunkten och arbetsstyckets nollpunkt (nollposition) i EJ flyktigt minne. Därefter om strömbrottet eller DRO stängs av kan vi återhämta oss arbetsstyckets nollpunkt (nollposition) genom att förinställa displayens nollpunkt position som lagrat avstånd från refpunkten .

En absolut utgångspunkt bör ställas in när ett arbetsstycke bearbetas. Det finns tre lägen (REF, AB, LEF, AB):

Exempel: lagra X-axelns arbetsdatum.

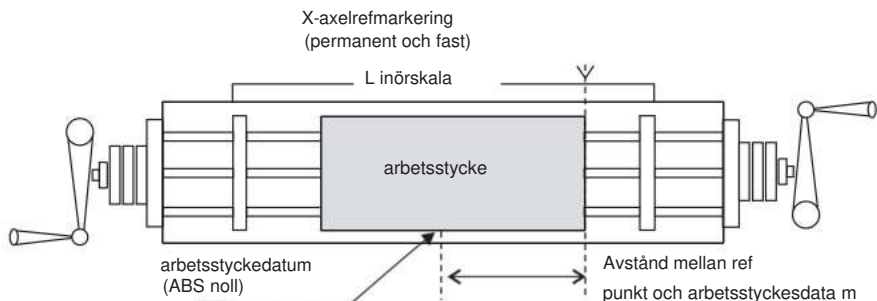

## General Operations

### Example for REF mode :

1、 DRO is set in ABS coordinate. Press **REF** , then the message window display “REF” .

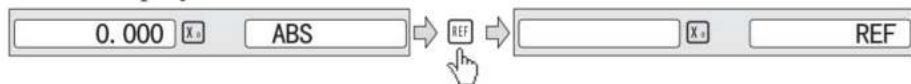

2、 Message window displays “REF” , Press **ENT** until “FD\_REF” appears in message window.



3、 Select the axis which need search RI. For instance : select X axis, then press **X** . “X\_REF” is displayed in message window, and X axis window flashes.

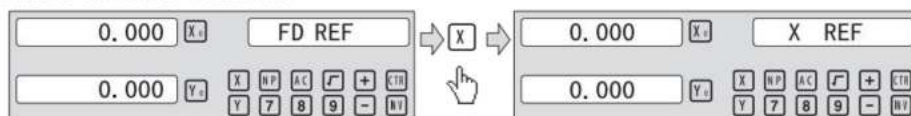

4、 Move the machine table .The buzzer sounds when RI is searched, then X window stops flashing and displays the value of the current position .the DRO returns normal display state. Then message window displays “FIND\_X” .

### Example for AB mode :

1、 DRO is set in ABS coordinate. Press **REF** , then the message window display “REF” .

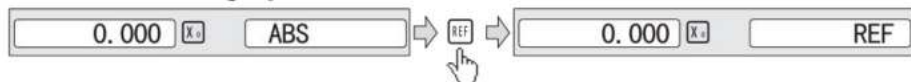

2、 Press **▲** **▼** , then the message window display “AB” .



3、 Message window displays “AB” , Press **ENT** until “FIND\_AB” appears in message window.

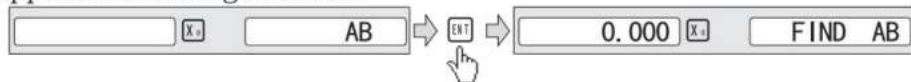

## General Operations

4、 Select the axis which need search RI. For instance : selct X axis, then press **X** . “X\_REF” is displayed in message window, and X axis window flashes.

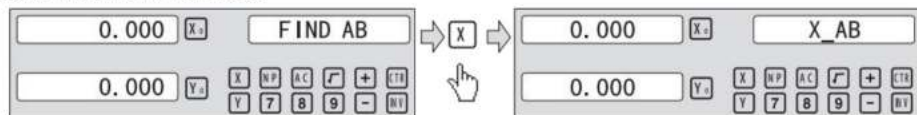

5、 Move the machine table .The buzzer sounds when RI is searched, displays the value of the current position for the absolute datum zero. the DRO returns normal display state. Then message window displays “FIND\_AB” .

### Example for LEF\_AB mode :

1、 DRO is set in ABS coordinate. Press **REF** , then the message window display “REF” .

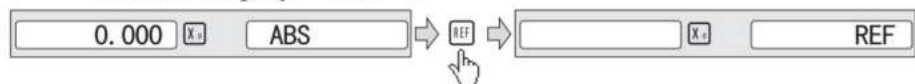

2、 Press **▲** **▼** , then the message window display “AB” .

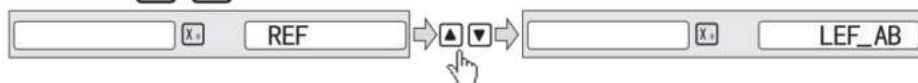

3、 Message window displays “LEF\_AB” , Press **ENT** until “ZERO\_AB” appears in message window.

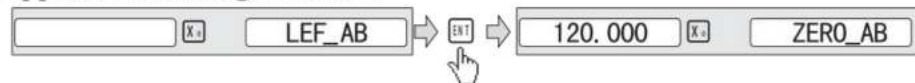

4、 Move the machine table to be set zero position piont. then press **X** , X axis will be zeroing . the current position for the absolute datum zero. the DRO returns normal display state.

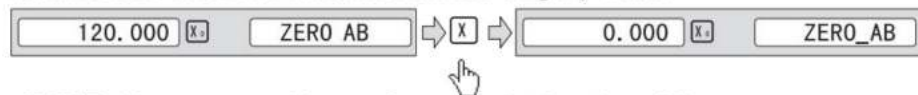

NOTE: Linear range without reference point location of the user

## General Operations

### 4.10 Non Linear Error Compensation

First compensation Type ( Linear or Non-Linear) in parameter setting must be set Non-Linear. Linear scale have a ref point location and find to the Absolute Reference Point will be enable.

Default Non-Linear compensation : 50.

#### Example for Y axis:

Step 1: Search the Absolute Reference Point of Scale;

Step 2: Press **[NP]** , then the message window display “COMP X” .



Step 3: Press **[▲]** **[▼]**, then the message window display “COMP Y”



Step 4: Press **[ENT]**, then the message window display “NUMBER” .

Then input the compensation parameter NUMBER.



Step 5: Press **[▲]** **[▼]**, then message window displays “Y-MSN-1” which indicates the step is to Non Linear Error Compensation.

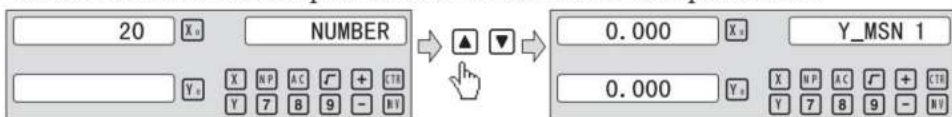

Step 6: Input compensation value .

X window display the value of the measurement value.

Y window display the value of the standard value.

Example for the first compensation point:

Measurement value :68.288mm. Standard value: 68.200mm



Step 7: After input all parameter, the DRO automatically exit.



2、 Set the point sdm1 as the datum of SDM 1. Move the machine worktable to  $x = 60.000$ ,  $y = 45.000$ . Then proess  $X_0$   $Y_0$ .

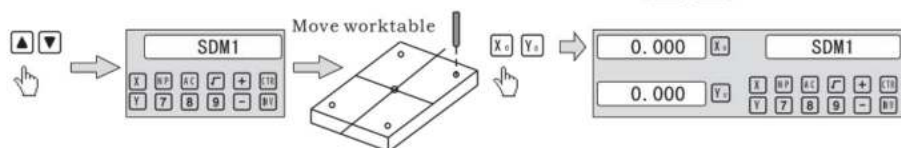

2、 Set the point sdm1 as the datum of SDM 2. Move the machine worktable to  $x = 60.000$ ,  $y = -45.000$ . Then proess  $X_0$   $Y_0$ .

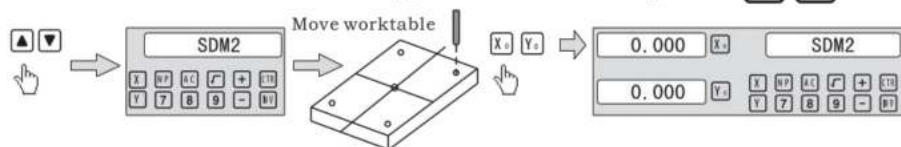

3、 Set the point sdm1 as the datum of SDM 3. Move the machine worktable to  $x = -60.000$ ,  $y = -45.000$ . Then proess  $X_0$   $Y_0$ .

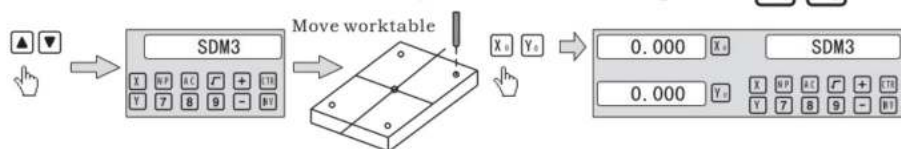

4、 Set the point sdm1 as the datum of SDM 4. Move the machine worktable to  $x = -60.000$ ,  $y = 45.000$ . Then proess  $X_0$   $Y_0$ .

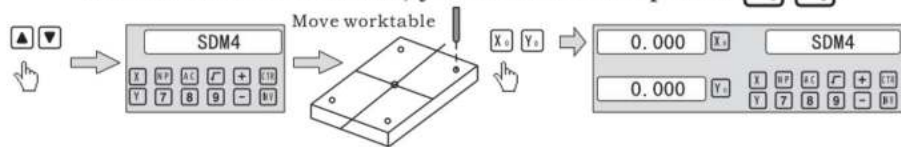

## 5.2 Preset datum of SDM coordinate

There are the same sample as Method 1. First Move the worktable to place the TOOL exactly at the origin of ABS, secondly Enter the ABS Mode as follow.

### Steps:

1、 Move worktable to place the TOOL at the center of the workpiece point O as the datum of ABS. Then zero X axis and Y axis in SDM 1 ; Zero X axis and Y axis in SDM 2 ; Zero X axis and Y axis in SDM 3 ; Zero X axis and Y axis in SDM 4.

## 200 Groups SDM coordinate

2、 Set point sdm1 as the datum of SDM 1. Press  $\blacktriangle$   $\blacktriangledown$ , then the message window display “SDM 1” . Input  $x = 60.000$ ,  $y = 45.000$ .

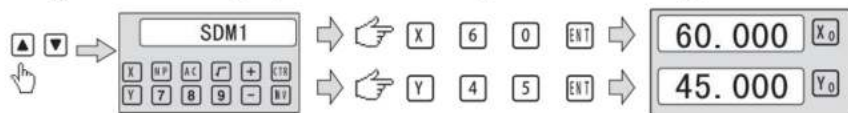

3、 Set point sdm1 as the datum of SDM 2. Press  $\blacktriangle$   $\blacktriangledown$ , then the message window display “SDM 2” . Input  $x = -60.000$ ,  $y = 45.000$ .



4、 Set point sdm1 as the datum of SDM 3. Press  $\blacktriangle$   $\blacktriangledown$ , then the message window display “SDM 3” . Input  $x = -60.000$ ,  $y = -45.000$ .

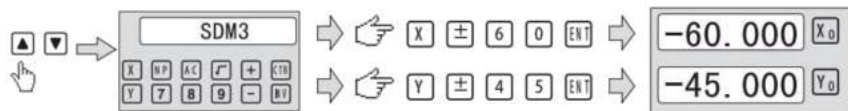

5、 Set point sdm1 as the datum of SDM 4. Press  $\blacktriangle$   $\blacktriangledown$ , then the message window display “SDM 4” . Input  $x = -60.000$ ,  $y = 45.000$ .

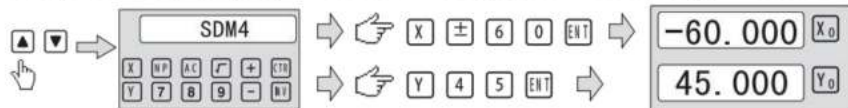

## 6, specialfunktion

## Circumference Holes Processing

### 6.1 Circumference Holes Processing

The Function of PCD Hole positioning on Circumference is used to distribute arc equally, such as boring hole on flange. The right window will show the parameter to be defined when selecting PCD Function.

The Parameters to be defined are:

PCD_XY(XZ,YZ)	Select place
CENTER	Center position
DIA	Diameter of circle
NO_HOLE	Hole number
ST ANG	Starting angle
ED ANG	Ending angle

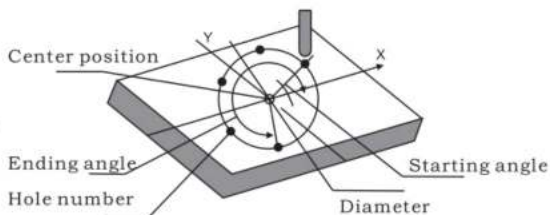

The position of the hole center are calculated automatically after input all parameters. Press or to choose the hole No. and move the machine table until the “0.000” appears in X window , Y window, Z window. It is the position to process a table.

Example for the XY place: Machine hole on circumference as the figure

PCD_XY(XZ,YZ)	XY
CENTER	X=0,000,Y=0.000
DIA	100,000
NO_HOLE	5
ST ANG	30,000
ED ANG	315,000

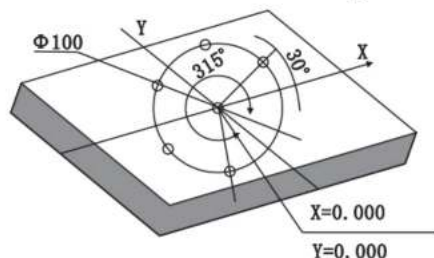

Steps:

1. Set display unit to metric in normal state; Move the machine table until the machine TOOL is aligned with the center of the circle , then zero X axis ,Y axis.

2. Select place.

Press , then the message window display “PCD\_XY” to the Circumference Holes Processing. Press or to select XY place.



## Circumference Holes Processing

## 2. Input center position.

Press **ENT**, then the message window display “CENTER”. X and Y window displays the formerly preset center position. Input X = 0, Y = 0 as follow.

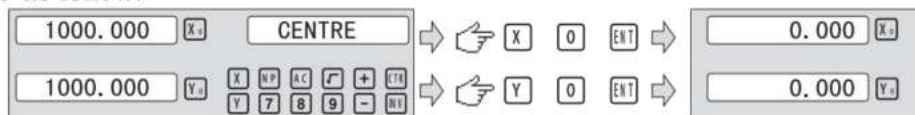

## 4. Input diameter.

Press **▼** until “DIA” appears in the message window. X window displays the formerly preset diameter. Then input the diameter is 100.000.

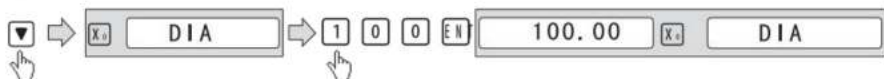

## 5. Input number.

Press **▼** until “NO\_HOLE” appears in the message window. X window displays the formerly preset number. Then press **5** in turn to input number.



## 6. Input starting angle.

Press **▼** until “ST ANG” appears in the message window. X window displays the formerly preset the starting angle. Then press **30** in turn to input the starting angle.



## 7. Input ending angle.

Press **▼** until “ED ANG” appears in the message window. X window displays the formerly preset the ending angle.. Then press **315** in turn to input the ending angle.

## Circumference Holes Processing

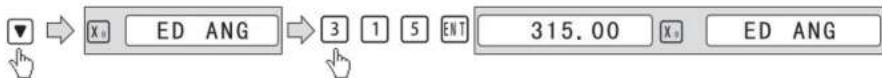

8. Press  until “NO 1” appears in the message window.

It is the position of the first hole to punch where the “0.000” is displayed in X window and Y window by moving the machine table.

After finishing the first hole, press  or  to change holes number.

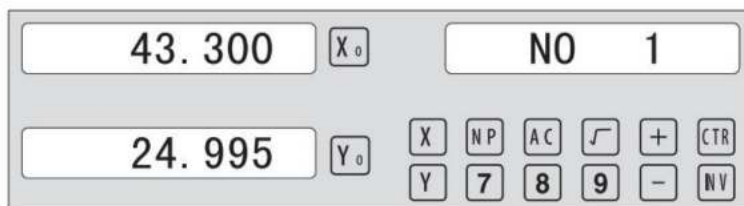

9. After processing all holes, press  to return normal display.

## Linear Holes Processing

### 6.2 Linear Holes Processing

There are two modes to carry out the linear drilling: Length mode and Step mode.

1.LINE S	Step mode
LINE L	Length mode
2.STEP	Step length
LENGTH	Line length
3. ANG	Angle
4. NO.HOLE	Hole number

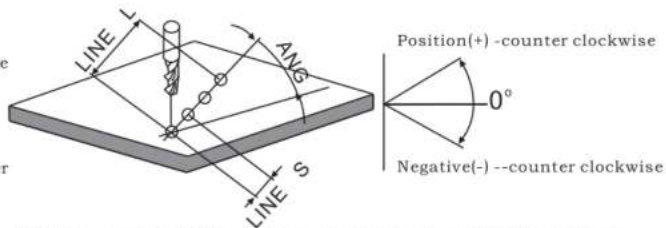

Linear Holes function can simplify the processing multiple holes whose centers are attributed equally on one line.

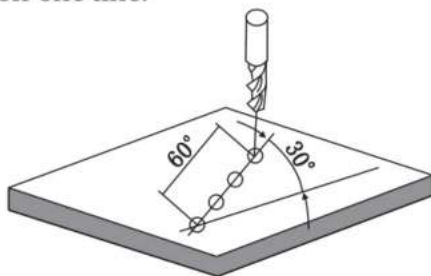

Example :

LINE_L	Length mode
LENGTH	60.000
ANG	30.000
NO.HOLE	4





Steps :

1. Select piece.

Press , then the message window display "LINE\_XY" to the Linear Holes Processing. Press  or  to select XY place.



2. Select Linear Holes mode.

Press , then the message window display "LINE\_S". Press  or  to select "LINE\_L".



3. Input linear length;

Press , then the message window display "LENGTH".

## Linear Holes Processing

X window displays the formerly preset the linear length. Press **6** **0** in turn to input the linear length.



## 4. Input angle;

Message window displays “ANG” which indicates the step is to angle. X window displays the formerly preset the angle. Press **3** **0** in turn to input the angle.

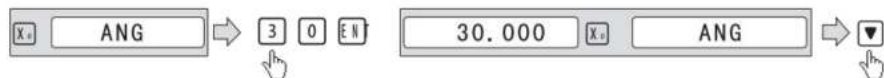

## 5. Input number;

Message window displays “ANG” which indicates the step is to angle. X window displays the formerly preset the number. Press **4** in turn to input the number.



6. Press **▼** until “NO 1” appears in the message window.

It is the position of the first hole to punch where the “0.000” is displayed in X window and Y window by moving the machine table. After finishing the first hole, press **▲** or **▼** to change holes number.

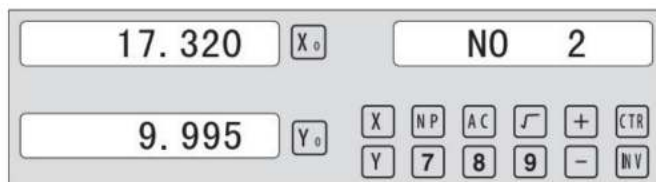

7. After processing all holes, press **☒** to return normal display.

## 6.3 ARC-bearbetning

TVÅ funktioner är tillgängliga för ARC-funktionen: den enkla ARC

Funktion och den mjuka R-funktionen - tryck sedan på pr css



för att gå in i ARC-funktionen,



eller



för att välja smidig ARC-funktion eller enkel

ARC-funktion.

Under installationen, normalt koordinaten för maskinen och den riktning X, Y , Z är enligt följande. Arbetsplanet visas SOM

höger figur.

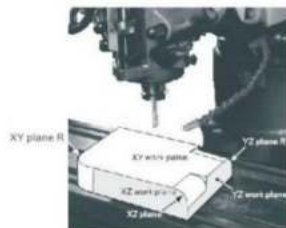
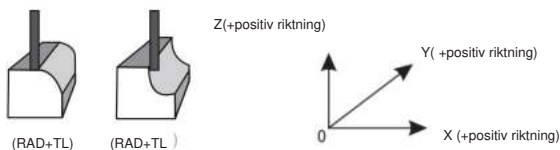

enkel ARC-funktion:

när jämnheten inte är mycket efterfrågad, SIMPLE ARC

funktionen används normalt för bearbetning av ljusbåge. I SIMPLE-funktionen

det finns bara åtta typer av ARC Används för att bearbeta. Operatören bara

välj typ av R och mata in parametrarna för bågens radie

MAX CUT och yttre Rrc eller inner rbåge. I allmänhet kan en båge vara

bearbetade av en plan slits T dem i olika OOL Eller arc TOOL, skillnaden mellan arbetsplan enligt bilden enligt följande .

- |                   |                             |
|-------------------|-----------------------------|
| 1 , ENKEL         | enkel bearbetning           |
| 2 , TYP 1 - 8     | Läge för ARC.               |
| 3, SEL_XY(XZ, YZ) | välj plats<br>Bågradie      |
| 4 , RAD           | Verktygsdiameter            |
| 5, TL HONOM       |                             |
| 6y MAX SNITT      | Matningssteg                |
| 7y RAD TL _       | yttre båge och<br>inre båge |

(endast för xy plats)

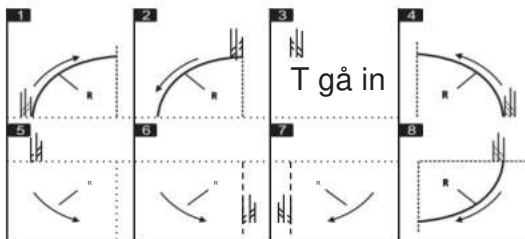

**Smooth ARC function :**

Provides maximum flexibility in ARC machining, the ARC sector to be machined by the coordinates of ARC. Very flexible, ARC function can machine virtually all kinds of ARC, ever the intersected ARC. Relatively a bit complicated to operate, operator need to calculate and enter the coordinates of ARC centre, start angle and end angle.

Basic parameter as follow:

1. SMOOTH	Mode of the Smooth ARC processing;
2. SEL_XY(YZ, XZ)	Select place;
3. CENTER	Refer to the position of an center.
4. RAD	Radius of the ARC
5. TL_DIA	Diameter of the TOOL
6. MAX_CUT	Feed step
7. ST_ANG	Starting angle
8. ED_ANG	Ending angle
9. RAD+TL	Outer arc.
RAD-TL	Inner arc.

**Example 1 for the Simple ARC Processing:**

Parameters settings as follow:

SIMPLE	Simple mode
TYPE	3
SEL_XY	XY
RAD	80.000
TL_DIA	6.000
MAX_CUT	0.500
RAD+TL	1

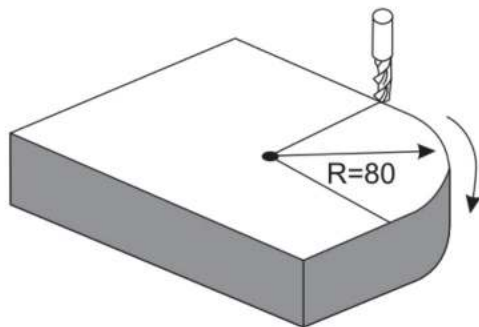
**Steps:**

1. Select process mode

Press  , then the message window display “SIMPLE” to the ARC Processing. Press  or  to select mode of the simple, The message window display “SIMPLE”

## ARC Processing



2. Input the type:

Press **ENT** until “TYPE” appears in the message window. X-window displays the formerly preset type. Press **3** in turn



3. Select place

Press **ENT** until “SEL\_XY” appears in the message window.

Press **▲** or **▼** to select place to display “SEL\_XY”;



4. Input radius:

Press **ENT** until “RAD” appears in the message window. X-window displays the formerly preset radius of ARC. Press **80** in turn to input the radius.;



5. Input Diameter of the TOOL

Press **▲** or **▼** until “TL DIA” appears in the message window. X-window displays the formerly preset Diameter of the TOOL. Press **6** in turn to input the Diameter value;



6. Input Feed step (MAX\_CUT);

Press **▲** or **▼** until “MAX\_CUT” appears in the message window. X-window displays the formerly preset MAX\_CUT. Press **0.5** in turn to input the MAX\_CUT value;



## ARC Processing

## 7. Select outer arc or inner arc

Press or until “RAD-TL” appears in the message window. Press or to select place to display “RAD+TL” ;

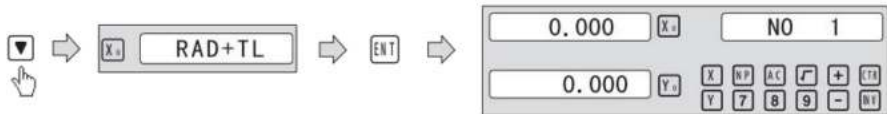

## 8. After inputting all parameters, press the key for machining.

The DRO will display the position of the first point. Retract the axes until the displays read 0.000, Machine the Arc point by point in accordance with the display. After finishing the position of the first point, press or to change position point.

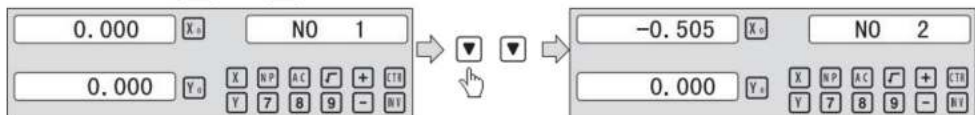

Press to quit R function any time.

**Example 2 for the Simple ARC Processing:**

Parameters settings as follow:

SIMPLE	Simple mode
TYPE	3
SEL_XY	XZ .....
RAD	80.000 .....
TL_DIA	6.000 .....
MAX_CUT	0.500 .....

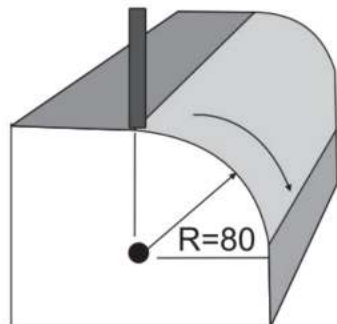

Steps:

1. Press , then the message window display “SIMPLE” to the ARC Processing. Press or to select mode of the simple, The message window display “SIMPLE”

## ARC Processing



2. Input the type:

Press **ENT** until “TYPE” appears in the message window. X-window displays the formerly preset type. Press **3** in turn



3. Select place

Press **ENT** until “SEL\_XZ” appears in the message window.

Press **▲** or **▼** to select place to display “SEL\_XZ” ;



4. Input radius:

Press **ENT** until “RAD” appears in the message window. X window displays the formerly preset the radius of ARC. Press **80** in turn to input the radius.;



5. Input Diameter of the TOOL

Press **▲** or **▼** until “TL DIA” appears in the message window. X window displays the formerly preset the Diameter of the TOOL. Press **6** in turn to input the Diameter value;



6. Input Feed step (MAX\_CUT);

Press **▲** or **▼** until “MAX\_CUT” appears in the message window. X window displays the formerly preset the MAX\_CUT. Press **0.5** in turn to input the MAX\_CUT value;



## ARC Processing

7. After inputting all parameters, press the key **ENT** for machining.

For 2-axis milling machine table, It is not installed with Z-axis, please press **▲** or **▼** to simulate position of Z-axis. Press **▲** simulate moving to the former process, and press **▼** simulate moving to the next process point.

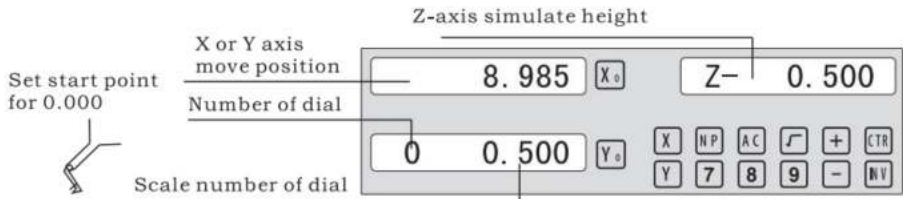

Z-axis simulate height = Number of dial x Z axis Dial + Scale number of dial

Press **▼** to quit R function any time.

### Example 3 for the Smooth ARC function:

Parameters settings as follow:

SMOOTH	Smooth mode
SEL_XY(YZ,XZ)	XY
CENTER	X=0,Y=0
RAD	80.000
TL_DIA	6.000
MAX_CUT	0.500
ST_ANG	0.000
ED_ANG	135.000
RAD+TL	1

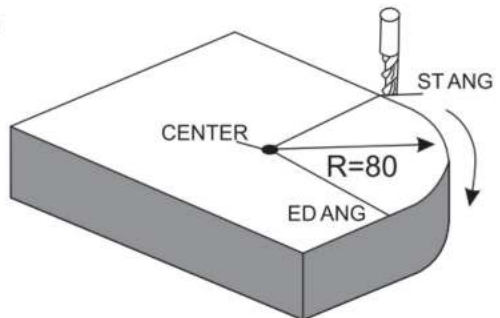

Steps:

1. Press **▼**, then the message window display "SIMPLE" to the ARC Processing. Press **▲** or **▼** to select mode of the simple, The

## ARC Processing

message window display “SMOOTH” ; For 3-axis milling machine table without this step. In second step. Then press **ENT** .



### 2. Select place

Message window display “SEL\_XY” which indicates the select is to place. Press **▲** or **▼** to select place to display “SEL\_XY” ;

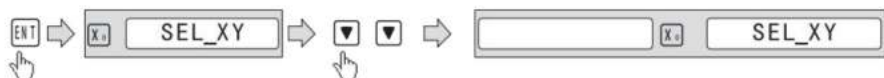

### 3. Input center position.

Press **ENT** , then the message window display “CENTER” . X and Y window displays the formerly preset center position. Input X = 0, Y = 0 as follow.

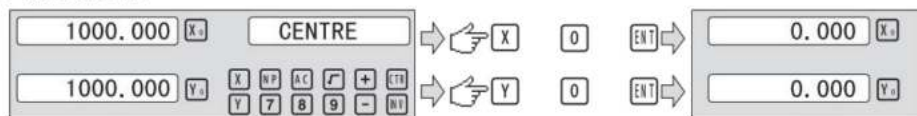

### 4. Input radius:

Press **ENT** until “RAD” appears in the message window. X window displays the formerly preset the radius of ARC. Press **8** **0** in turn to input the radius.;



### 5. Input Diameter of the TOOL

Press **▲** or **▼** until “TL DIA” appears in the message window. X window displays the formerly preset the Diameter of the TOOL. Press **6** in turn to input the Diameter value;





## BÅGE Processing

## 6. Inmatningssteg (MAX\_CUT);

trycka  eller  tills UMAX CUT app bilar i meddelandet

fönster. X Window de spa lyser den tidigare förinställda MAX\_CUT. trycka

   i sin tur att mata in MAX CUT-värdet; \_

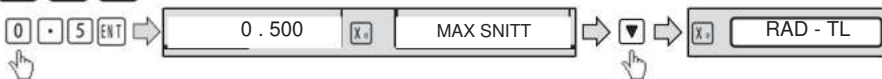

## 7. Ingångs startvinkel .

trycka  tills USTANG" visas i meddelandefönstret. x

window de spa lyser den tidigare förinställda startvinkeln . Tryck sedan

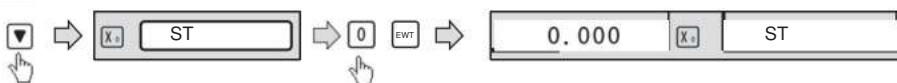

 i sin tur för att mata in startvinkeln-



## 8. Ingångsslutvinkel .

trycka  tills UED ANG" visas i meddelandefönstret. X

fönstret visar den tidigare förinställda slutvinkeln. Tryck sedan på 1

  i sin tur för att mata in endin8-vinkeln-



## 9. välj yttre båge eller inre båge

tryck  eller  tills "RAD-TL" visas i meddelandet

fönster. tryck  eller  för att välja plats för att visa "RAD+TL" ;

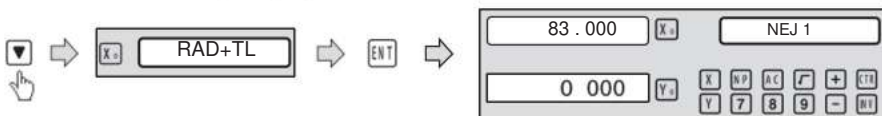

## 10. Efter att ha matat in alla parametrar,

**machining.**

DRO kommer att visa positionen för den första punkten. Dra tillbaka

axlar tills displayerna visar 0.000, Bearbeta bågen punkt för punkt in

i enlighet med displayen. Efter att ha avslutat positionen för den första

peka, tryck  eller  för att ändra positionspunkt.

## ARC Processing

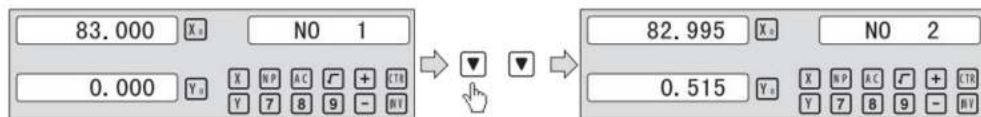

Press  to quit ARC function any time.

## 6 . 4 sned bearbetning

Det finns två tillgängliga sätt att bearbeta en sned plats:

A). på platsen. b). på platsen yz, eller Xz;

endast följande parametrar behöver matas in:

INKL Xy(xz,yz) ställ in maskinplats xy,yz,0rxz plats ·

DE Lutningsvinkeln för den sneda·

DET VERKTYGSdiametern ·

ST POT Startposition;

ED KAN Slutpostering;

Exempel 1 för den sneda xyplace:

när bearbetningsplanet är i plan xy som den del som visas i

Figur, arbetsstyckets snedvinkel ska kalibreras

innan det sneda planet bearbetas. Därför

, vid denna tidpunkt

bearbetning av snedplan spelar rollen att kalibrera snedställningen ·

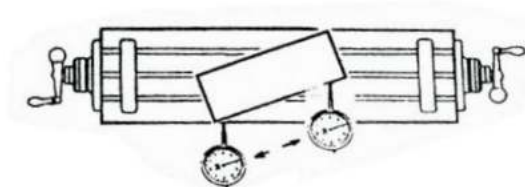

förfarande för att kalibrera snedställningen

Placera först arbetsstycket på arbetsbordet enligt önskad vinkel av snedhet ·

1) Ange funktionen för snedplan. 2) välj

funktionen för planet XY.

3) Mata in snedvinkeln·

4) Flytta arbetsbordet tills mätverktyget (som en mätklocka)

installerad på fräsmaskinen vidrör det sneda kalibreringsplanet, justera det till noll och flytta arbetsbordet för valfritt avstånd i

riktning på x-axeln. \_



5) Flytta arbetsbordet i avståndet från y-axeln tills displayen visas blir noll.

## Oblique Processing

6) Change the angle of the work piece to make the workpiece touch the measuring tool and adjust it to zero.

STEPS:



1. Select place

Press , then the message window display "INCL\_XY" to the Oblique Processing. Press  or  to select place to display "SEL\_XY";

Then press  to in next step;



2. Input the angle of obliquity

The message window display "ANG" , X window displays the formerly preset the angle of obliquity. Press   in turn to input the angle of obliquity .



3. Move the workpiece along the X-Axis until the measuring tool touches the workpiece adjust it to zero, and move the worktable for any distance along the X-Axis.



4. Press , display the value of Y-Axis. Move the workpiece along the Y-Axis, change the angle of workpiece to make the obliquity-calibrating plane touch the measuring tool until it turns to zero. Move the worktable until Y-Axis is displayed as zero.

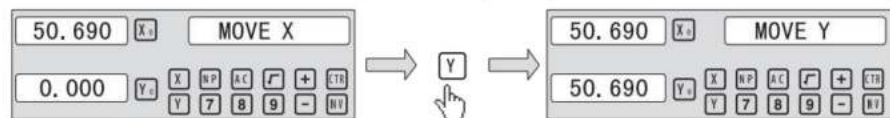

5. Press  to quit oblique function any time.

## Oblique Processing

### Example 2 for the oblique XZ or YZ place:

When the machining plane is on plane XZ or YZ, the function of TOOL inclination can instruct the operator to machine the oblique plane step by step.



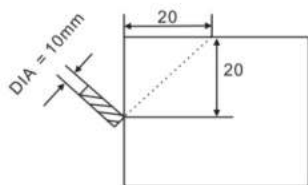
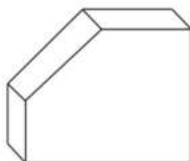

Procedures for using the function of cutter inclination:

When the machining plane is on plane XZ or YZ, first please calibrate the obliquity of the primary spindle nose and set the TOOL:

INCL_XY(XZ,YZ)	INCL_XZ
DIA	10.000
ST_POT	20.000
ED_POT	20.000





#### STEPS:

1. Press , then the message window display “INCL\_XY” to the oblique Processing. Press  or  to select place to display “SEL\_XZ; Then press  to in next step;



2. Input The TOOL Diameter

The message window display “DIA” , X window displays the formerly preset the angle of obliquity. Press   in turn to input the TOOL Diameter of obliquity . OK, then press  to in next step;



3. Input ST\_POT;

The message window display “ST\_POT” , X and Y window displays the formerly preset the stating position of obliquity. Input X= 0, Y = -20.000. OK, then press  to in next step;

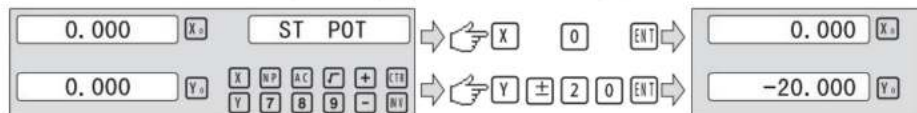



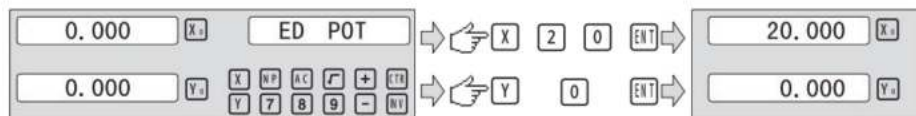

## Oblique Processing

### 4. Input ED\_POT;

The message window display “ED\_POT” , X and Y window displays the formerly preset the starting position of obliquity. Input X= 20.000, Y = 0.000 .



### 5. After input all parameter, press the key for machining.

For 2-axis milling machine table , It is not installed with Z-axis, please press  or  to simulate position of Z-axis. Press  simulate moving to the former process, and press  simulate moving to the next process point.

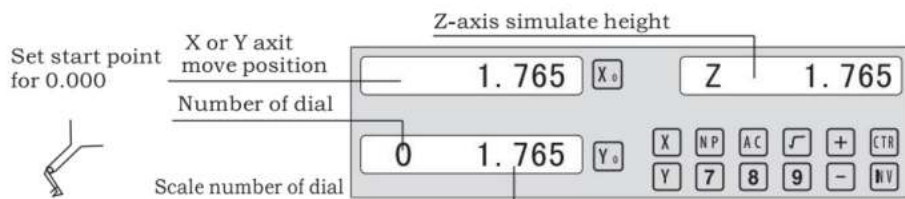

Z-axis simulate height = Number of dial x Z axis Dial + Scale number of dial

Press  to quit **oblique** function any time.

## Slope Processing



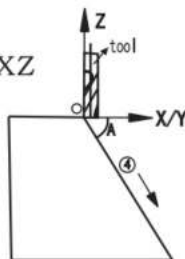

## 6.5 Slope Processing

This function can calculate the position of every processing point automatically in processing slope. Only the following parameters need to be inputted:

XZ, YZ	Set machine place YZ, or XZ
ANG	The inclination angle
Z_STEP	The slope length each time processing



**Example 1 for the Slope XZ place;**

Step 1. Select place

Press , then the message window display “XZ” to the slope Processing. Press  or  to select place to display “SEL\_XY; Then press  to in next step;





Step 2. Input the angle of slope

The message window display “ANG”, X window displays the formerly preset the angle of slope. Press   in turn.



Step 3. Input Z\_step;

The message window display “Z STEP”, X window displays the formerly preset the stating position of slope. Input    in turn.



Step 4:Finishing the ALL processing . Press  to quit slope function any time.

## Chambering Processing

### 6.6 Chambering Processing

1,FLAT\_XY: machine place; 2, DIA:diameter of TOOL; 3, CENTER: center of the chambering ; 4, SIZE: size of the chambering ;

Figure as follow:

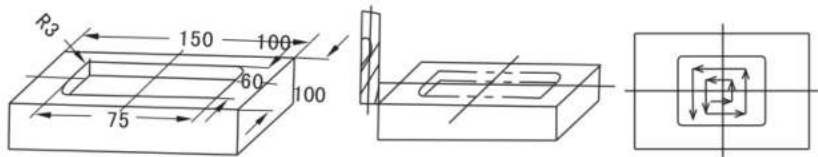

STEPS:

1. Press , then the message window display “FLAT\_XY” to the Chambering Processing.



2. Input DIA of the TOOL;





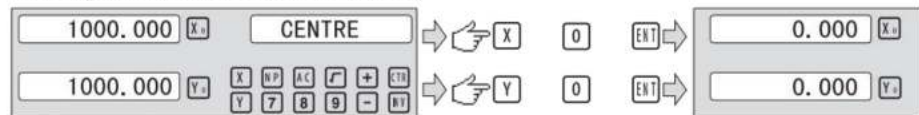

3. Input the center coordinate;

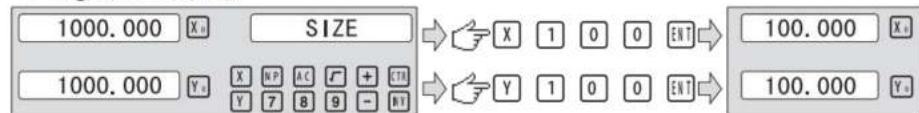

4. Input the size;



5. process Chambering;

Move the machine until the display of the axis is zero,ie, the position of the first point. Machine the first point . Display the next machining point by pressing  or  .On the completion of machining, the right window shows OVER. Press  or , the system will goto the first position for the next workpiece. Press  to quit the Chambering Function.

## The Tool Diameter Compensation Function

### 6.7 The Tool Diameter Compensation Function

Without TOOL compensation, the operator has to move the TOOL for an additional distance of the diameter of the TOOL along each side when machining the four 150 and 100 sides of a workpiece to finish machining the whole brim. The digital readouts shall automatically compensate when the TOOL compensation function is enable.

Note: the TOOL compensation is made in the direction of X and Yaxis.

Procedures:

- 1). Enter the function of compensating the diameter of the TOOL.
- 2). Select one of the (four) preset machining modes.
- 3). Input the diameter of the TOOL.
- 4). Enter machining.

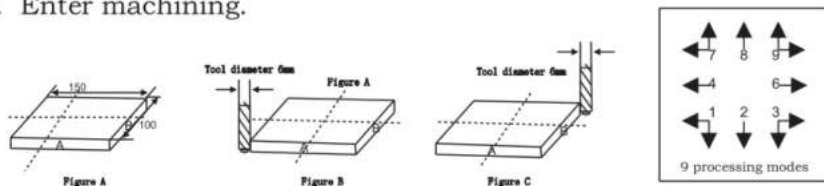

Step1: press  $\frac{D_m}{13}$  to enter the TOOL compensation Function. then the message window display “TYPE” .Press **9** .



Step 2: input the diameter of the TOOL; Press **1** **0** in turn..



Step 3: Press  $\nabla$  to the machining Mode.

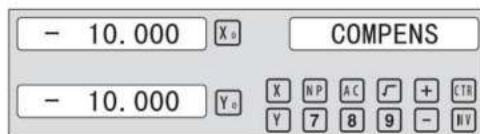

Machining of 2 side planes can be done by moving the TOOL until X-Axis is 150.000 and Y-Axis is 100.000.Press the Key  $\frac{D_m}{13}$  to quit the Function.

## The Tool Diameter Compensation Function

---

### 6.8 Digital Filter of the Grinding Machine

When machine a work-piece by grinder, the display values quickly due to the vibration of grinder. User can not see display value clearly. Grinder DRO provides display value filter function to disable the quake change of display value.

STEPS:

1. Enter display value filter function.

In normal display state, press **SFT** to simultaneously, enter display value filter function.

2. Exit display value filter function;

Press **SFT** , exit display value filter function;

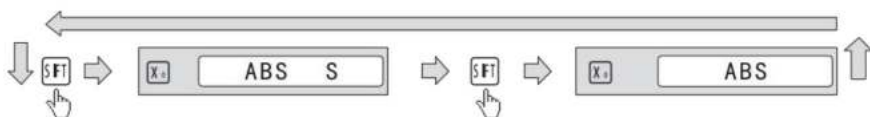

## 6.9 La funktionen

### 6.9.1 200 set VERKTYG Libs

Den behöver alltid olika VERKTYG vid bearbetning av olika delar. För bekväm drift, La de digitala avläsningarna har funktionen av 200 set VERKTYG Libs.

Obs: endast när la the är utrustad med verktygsinställningsblocket kan de 200 seten TOOL Libs, användas.

1. ställ in ett datum VERKTYG. Efter verktygsinställning, noll x-axel och Z-axel, den sätt noll för absolut koordinat.

2. Beroende på storleken på TOOL I och datumTOOL, bestämt position för VERKTYG i förhållande till nollpunkten för absoluta koordinat- och nollpunktsverktyget. AS Figur 6-1. Den relativa storleken på VERKTYG 2 är enligt x-axeln 25-30= 5, Z-axel 20-10=10.

3. spara VERKTYG-numret och storleken i digital avläsning.

4. Antalet VERKTYG Kan matas in slumpmässigt, de digitala avläsningarna kommer att visa verktygets position till absolut koordinat noll. Flytta la the tills X-axeln och Z-axeln båda visar noll. 5. TOOL Libs kan spara de 200 uppsättningarna av verktygsdata.

6. TOOL Libs måste användas i öppningsläge. De 200 seten rooi Libs KAN öppnas genom att kontinuerligt trycka på  tio gånger tills det högra fönstret blinkar TL - OPEN och en markering "21" visas vid till vänster om det högra informationsfönstret. Märket indikerar

operatör KAN ställa in eller revidera de 200 uppsättningarna VERKTYG Lib s. kontinuerligt genom att trycka på  tio gånger kommer att göra att 200 sets TOOL Libs blir knappen stängd och det högra fönstret blinkar TL - CLOSE och markeringen försvinner. när markeringen "21" försvinner kan de 200 uppsättningarna TOOL Libs inte revideras.

Operationerna för TOOL-data och anrop av TOOL visas enligt följande. steg 1: I ABS-tillstånd, mata in data för de 200 uppsättningarna TOOL Libs. TILL öppna 200 sets TOOL Libs genom att kontinuerligt trycka på knappen  tio gånger. A. Markera "" kommer att visas i det vänstra fönstret till höger infofönster.

## Lathe Function

steg 2: tryck **TOOL** för att komma åt inmatningsläget. Mata in rooi 1-data:

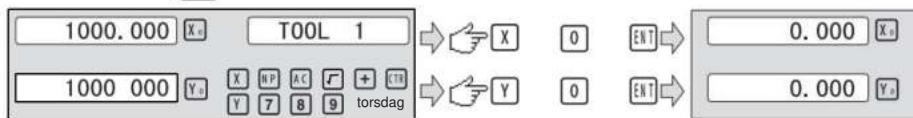

steg 3: Mata in TOOL 2-data:

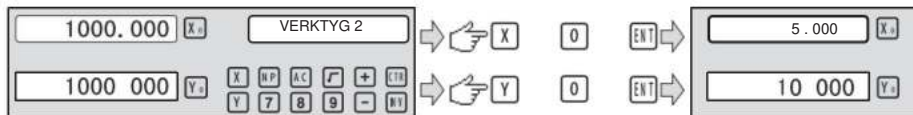

steg 4: tryck på **TOOL** för att fortsätta att mata in data för nästa verktyg. GENOM att trycka nummer och nyckeln operatören kan mata in specialen direkt verktygsdata. trycka **TOOL** berör

Efter att TOOL libs har ställts in · använd TOOL libs enligt efter operationer montera först det andra verktyget ·

steg 5: För att komma åt användningstillståndet med pr css **CALL** . Sedan pr css **2** **ENT** **T** .



steg G: tryck **▲** eller **▼** · välj basvalet. Tryck sedan på **1** **OCH T** .



steg 7: tryck **CALL** för att avsluta funktionen;

Notera:

- när basverktyget används , axeln kan inte nollställas i ABS-tillstånd ·
- när de andra används , axeln kan endast nollställas i INC-tillstånd ·

### 6 . 9 . 2 Taper Funktion

För svarvning av arbetsstycket med kona kan arbetsstyckets kon mätas i bearbetning;

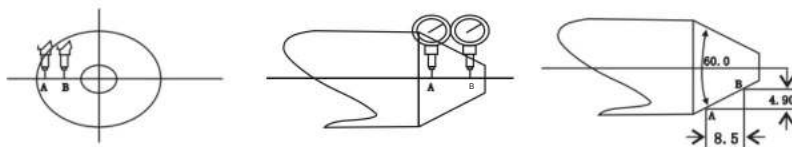

## Lathe Function

### Operations :

AS-figur, kontaktyta A Av arbetsstycke med spakavläsningar och återställer spakens avläsningar till noll .

steg 1: tryck sedan på  på meddelandefönstret visa "UMEASU" till pappersbearbetning . Flytta spakens avläsning till ytan B Tills spakavläsningar punkt SOM följer;



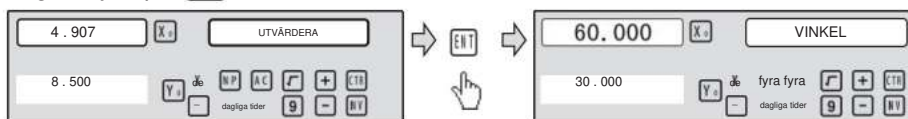

steg 2: tryck på  för att beräkna.



steg 3: tryck  för att avsluta funktionen;

### 6 . 9 . 3 R/D-funktion

För 2 x svarvar och 3 axlar svarv, tryck  , Visningsläget ofx-axeln växlas mellan Radie och Diameter. när x-axeln för visning av Diameter, A mark u  kommer att visas till vänster om höger informationsfönster, men när X-axeln för visning av ia meter  , märket " " försvinner . endast x-axeln har funktionen av diametern /radien transformation.

### 6 . 9 . 4 Y + Z Funktion (gäller endast: 3 axlar La the)

För 3 axlar La, räknaren på axeln och räknaren på z-axeln

Kan läggas till som visas i Z-axeln genom att trycka på knappen  , tryck sedan på knappen KAN avbryta y + Z-funktionen .

6.10 EDM (särskild anpassningsfunktion, om du behöver köpa, tack kontakta återförsäljaren för att anpassa)

1. Beskrivning: Denna funktion används för specialbearbetning av Elektrourladdningsbearbetning (EDM). När det inställda målvärdet för EDM Z-axeln är lika med det aktuella värdet, den digitala avläsningen kommer att mata ut switchsignal för att styra EDM för att stoppa djupbearbetningen.

Inställningen av Z-axelns riktning för den digitala avläsningen visas som Fig. 1, dvs. Ju djupare djupet är, desto stort är Z-axelns koordinatvärde visas sedan start av bearbetning kommer djupet gradvis att fördjupas och Z-axeln.

Enligt den inställda Z-axelns riktning är bearbetningsriktningen uppdelad i positiv och negativ bearbetning. När elektroden sjunker och bearbetningen utförs från upp till ner, det digitala avläsningsvärdet kommer att öka, vilket kallas positiv bearbetning (positiv). Inställningen av denna riktning är den normala inställningen.

När elektroden ASCEnds och bearbetningen utförs från ner till upp kommer det digitala avläsningsvärdet att minska. Den bearbetningsriktning är negativ riktning (negativ), vilket också kallas negativ bearbetning (visas som fig. 1)

Digital Readout har även andra funktioner, sådan AS negativ brandsäker höjd. Negativ brandsäker höjd funktion är ett slags intelligent position följ kontroll säkerhetsskyddsanordning. I processen vid bearbetning kommer elektrodytan att generera kolet ackumuleringsfenomen. På grund av den långa eller dagliga bearbetningen utan att tendera, när man genererar kolansamlingen och ingen gör rengöringen, elektroden kommer långsamt att öka längs med negativ riktning. När elektroden överstiger vätskenivån kommer den att göra det tar ofta eld och orsakar förluster. Denna funktion är bara inställd på mål vid detta problem. vid inställning av negativ brandsäker höjd, och den ökad höjd på elektroden överstiger höjden mellan den och djup av bearbetad yta (dvs. negativ brandsäker höjd), den digitala avläsningsdisplayen blinkar för WQring; samtidigt utgången signalen stängs automatiskt av EDM för att eliminera brandrisken.

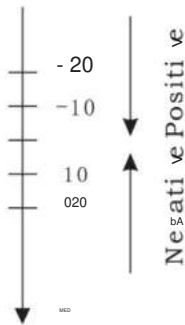

Figur 1

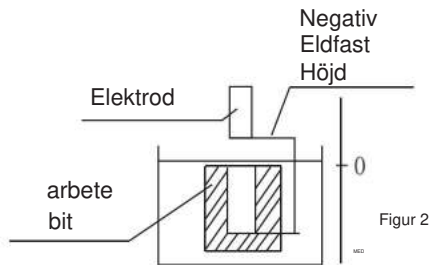

Figur 2

## 2 . procedur:

se följande exempel för detaljerad bearbetning

1) Före bearbetning, ställ först in varje parameter för DEPTH (bearbetningsdjup); ERRHIGH( negativ brandsäker höjd), bearbetning riktning (POSITIV / NEGATIV) ; utgångsläge (AUTO/STOPP) och EDM-reläutgångsläge · 2) Flytta

huvudaxelektroden på Z-axeln så att den kommer i kontakt med arbetsstyckesreferens · nollställ A-axeln eller ställ in värdet ·

3) Ange EDM-bearbetning genom att trycka på knappen .

4) X-axeln visar bearbetningsdjupets målvärde· Y-axeln kommer visningsvärdet har varit att vara djup. (Värdet på Y-axeln är värde att arbetsstycket har bearbetats djup) Z-axeln kommer visa självpositionsvärde i realtid. (Värdet på Z-axeln är positionsvärdet för huvudaxelektroden på z-axeln.)

5) starta bearbetningen, Z-axelns visningsvärde är gradvis nära

målvärde, andy-axelns visningsvärde är också gradvis nära

målvärde. Om vid denna tidpunkt elektroden upprepas upp och ner, kommer Z-axelns visningsvärde att ändras senare, men y-axelns visning

värdet kommer inte att ändras, vilket alltid visar det bearbetade djupet

**value.**

6) när Z-axelns visningsvärde är lika med det inställda målvärdet

omkopplaren för att nå positionen kommer att stängas av, EDM kommer att stoppa bearbetningen,

Enligt operatörsinställningen · Det finns två typer av utgångslägen:

## a) Automatic Mode:

it will automatically exit from EDM machining status and recover to the original state before machining;

## b) Stop Mode:

It will always stay at the machining interface after finishing machining, and you should press **EDM** to exit and back to the original state.

**Operation steps:**

**The DEPTH (machining Depth), ERRHIGH (Negative fireproof height), exit Mode, EDM Relay Output Mode and machining direction should be set.**

**STEPS:**

1. Press **EDM** to enter the EDM Function. Press **▲** to input parameters; Press **▼** to enter EDM machining state.

2. Input DEPTH ( machining depth). Press the key **▲** to set the next parameter.



3. input ERRHIGH ( Negative Fireproof Height ) (undefine) .Press the key **▲** to set the next parameter.



4. Set machining direction(Positive or Negative). Press **1** to select Positive direction. Press **0** to select Negative direction. Press the key **▲** to set the next parameter.



5. Set exit Mode (AUTO Mode or STOP Mode) Press **0** to select AUTO Mode; Press **1** to select STOP Mode ; Press the key **▲** to set the next parameter.

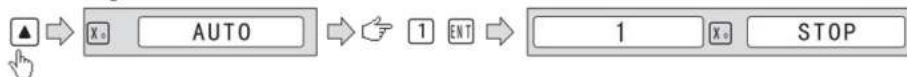

6. Set the Output Mode (Mode 0 or Mode 1); ( undefine ). Press **0** to select Mode 0; Press **1** to select Mode 1.

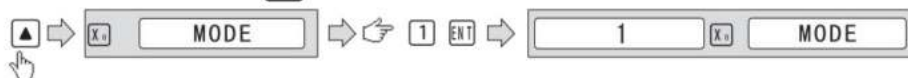

7. Continuously press **▼** to return EDM for machining. press **EDM** to quit the function;

### Example 1: positive direction machining ;

Machining is shown as the model chamber as follows

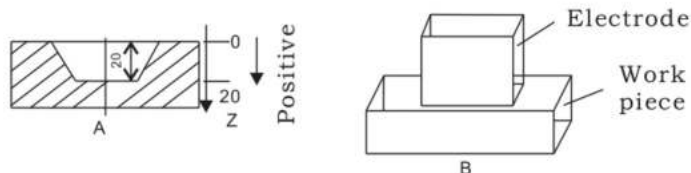

#### STEPS:

1、Touch one side of the workpiece with the TOOL, then press **Z0** , zero the Z axis.



2、 Press **EDM** , Setting DEPTH for 20.000; press **▼** to EDM for machining;



3、 Starting machining.

## EDM

Machining depth target value	<input type="text" value="20.000"/>	<input type="button" value="X0"/>	<input type="button" value="EDM RUN"/>
Value has been to be depth	<input type="text" value="0.000"/>	<input type="button" value="Y0"/>	
Self-position real time value	<input type="text" value="0.000"/>	<input type="button" value="Z0"/>	

**Example 2: Negative direction machining**

Machining is shown as the model chamber as follows

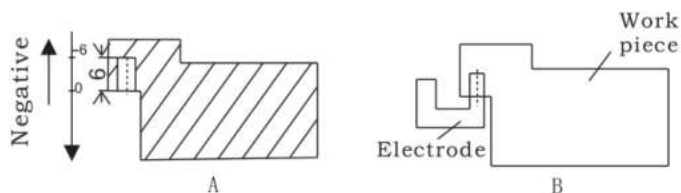

1. Touch one side of the workpiece with the TOOL, then press  , zero the Z axis.

<input type="text" value="1000.000"/>	<input type="button" value="Z0"/>	<input type="button" value="↔"/>	<input type="button" value="Z0"/>	<input type="button" value="↔"/>	<input type="text" value="0.000"/>	<input type="button" value="Z0"/>
---------------------------------------	-----------------------------------	----------------------------------	-----------------------------------	----------------------------------	------------------------------------	-----------------------------------

2. Press  , Setting DEPTH for -20.000; press  to EDM for machining;

<input type="button" value="EDM"/>	<input type="button" value="→"/>	<input type="button" value="X0"/>	<input type="text" value="DEPTH"/>	<input type="button" value="↔"/>	<input type="button" value="±"/>	<input type="text" value="20"/>	<input type="button" value="0"/>	<input type="button" value="ENT"/>	<input type="text" value="-20.000"/>	<input type="button" value="X0"/>	<input type="text" value="DEPTH"/>
------------------------------------	----------------------------------	-----------------------------------	------------------------------------	----------------------------------	----------------------------------	---------------------------------	----------------------------------	------------------------------------	--------------------------------------	-----------------------------------	------------------------------------

3. Starting machining.

Machining depth target value	<input type="text" value="20.000"/>	<input type="button" value="X0"/>	<input type="button" value="EDM RUN"/>
Value has been to be depth	<input type="text" value="0.000"/>	<input type="button" value="Y0"/>	
Self-position real time value	<input type="text" value="0.000"/>	<input type="button" value="Z0"/>	

**Example 3: PCD Function for EDM**

PCD Function can access the EDM Function . The operator enters PCD Function to input parameters for PCD and enter PCD machining state. At every position for machining, press the key  to access the EDM Function .

när EDM-funktionen går in, KAN operatören mata in parametrarna för EDM .

Operationsproceduren är som följer:

1) ställ in PCD-parametrar (inställningen är densamma som den vanliga inställningen av PCD)

Efter inmatning av alla parametrar och ange PCD-bearbetningstillstånd . Den positionen för det första hålet visas.

2) tryck på  för att ange parametern EDM Function (inställningsmetoden är samma som den vanliga inställningen för EDM-parametern); efter inmatning alla

parametrar , tryck kontinuerligt när  för att gå in i EDM-bearbetningstillstånd. bearbetningen är klar, tryck på enter PCD-  för att avsluta EDM-funktionen och bearbetningstillstånd .

3 )I PCD-bearbetningstillstånd, tryck  för positionen för nästa hål, ÖVER maskinen till visningsvärdet 0 , sedan pr css  att komma åt EDM-funktion igen . 4)

Upprepa steg 2 och steg 3 för följande bearbetningspunkter.

## Calculator

### 7 kalkylator

Kalkylatorn ger inte bara normala matematiska beräkningar som +, -,  $\times$ , /, det ger också trig på metriska beräkningar såsom AS SYND, Arc SIN, COS, Arc COS, SOLBRÄNNNA, Arc TAN SQRT etc.

Operationerna är desamma som de kommersiella miniräknare, lätta att använda. Gå in i och avsluta kalkylatorns funktion

i normalt displayläge: tryck på R för att gå in i kalkylatorfunktionen.

i räknarens visningsläge: tryck på R för att avsluta räknarfunktionen.

ÖverföringkalkulatorResultat vald zx är.

Efter att beräkningen är klar, om räknarens visningsläge är inställt för läge 1, användaren kan:

tryck på  $X_0$  att överföra den beräknade resultatet to x-axeln; sedan x-fönster för att visa detta värde;

trycka  $Y_0$  att överföra det beräknade resultatet leksaksaxeln; då de-fönstret kommer att visa detta värde;

tryck på  $Z_0$  att överföra det beräknade resultatet till z-axis; sedan z-fönster för att visa detta värde;

Överför det aktuella visningsvärdet i fönstret till kalkylatorn.

om räknaren visar Läge inställt för läge 1, användaren kan:

trycka  $X$  att överföra visningsvärdet i x-fönster till kalkylator;

trycka  $Y$  för att överföra visningsvärdet i Y Window för att beräkna r;

trycka  $Z$  för att överföra visningsvärdet i z-fönstret till räknaren;

## Appendix

## 8 Appendix

## 1. Troubleshooting:

The following are the preliminary solvents for troubleshooting.

If there is still trouble, Please contact out company or agents for help.

Troubles	Possible reasons	Solvents
No display	<ol style="list-style-type: none"> <li>1. Power isn't connected</li> <li>2. Power switch is off.</li> <li>3. The range of power voltage is not right.</li> <li>4. The inner power of Linear Scale is short.</li> </ol>	<ol style="list-style-type: none"> <li>1. Check power wire and connect the power</li> <li>2. Turn on the power switch.</li> <li>3. The range of voltage is in 80--260V</li> <li>4. Unplug the connector of linear scale</li> </ol>
One axis is not counting	<ol style="list-style-type: none"> <li>1. Replace the linear scale of the other axis.</li> <li>2. DRO is in special function</li> </ol>	<ol style="list-style-type: none"> <li>1. If count is normal, the linear scale has trouble; If abnormal, the DRO readouts has trouble.</li> <li>2. Quit the special function.</li> </ol>
Linear scale is not counting	<ol style="list-style-type: none"> <li>1. Reading head is bad for using range exceeds.</li> <li>2. Aluminum chips is in reading head of linear scale.</li> <li>3. The span between the reading head and metal part of linear scale is large.</li> <li>4. The metal parts of linear scale is damage.</li> </ol>	<ol style="list-style-type: none"> <li>1. Repair the linear scale</li> <li>2. Repair the linear scale</li> <li>3. Repair the linear scale</li> <li>4. Repair the linear scale</li> </ol>
Counting is error	<ol style="list-style-type: none"> <li>1. Shell is poor grounding.</li> <li>2. Low precision of machine.</li> <li>3. Speed of machine is too rapid.</li> <li>4. Precision of linear scale is low.</li> <li>5. The resolution of DRO readouts and the linear scale is not match.</li> <li>6. The unit (mm/inch) is not match.</li> <li>7. Setting the linear compensating is not arrest.</li> <li>8. Reading head of the linear scale is damaged.</li> </ol>	<ol style="list-style-type: none"> <li>1. Shell is good grounding.</li> <li>2. Repair the machine.</li> <li>3. Reduce the speed of machine.</li> <li>4. Mount the linear scale again.</li> <li>5. Set the resolution of the DRO again.</li> <li>6. Cover the unit of display mm/inch.</li> <li>7. Reset the linear compensation.</li> <li>8. Repair the linear scale.</li> </ol>
The counting of the linear scale is not accurate	<ol style="list-style-type: none"> <li>1. The mounting of linear scale does not demand the requirement, and the prcision is not adequate.</li> <li>2. The screw is loosen.</li> <li>3. Precision of machine is low.</li> <li>4. The resolution of digital readouts and the linear scale is not match.</li> </ol>	<ol style="list-style-type: none"> <li>1. Mount the linear scale again and level it.</li> <li>2. Lock all fixing screws.</li> <li>3. Repair the machine.</li> <li>4. Reset the resolution of digital readouts.</li> </ol>
Sometimes the linear scale is not counting	<ol style="list-style-type: none"> <li>1. The small car and steel ball is separated.</li> <li>2. The glass of reading head is wearied.</li> <li>3. The glass of reading head of the linear scale has dirt.</li> <li>4. The elasticity of the steel wire is not adequate.</li> </ol>	<ol style="list-style-type: none"> <li>1. Repair the linear scale.</li> <li>2. Repair the linear scale.</li> <li>3. Repair the linear scale.</li> <li>4. Repair the linear scale.</li> </ol>

## Appendix

### 2. Specifications of Digital Readout.

- 1) Supply Voltage range: AC 85 V ~ 230 V; 50 ~ 60 Hz
- 2) Power consumption: 15VA
- 3) Operating temperature: 0°C-- 50°C
- 4) Storage temperature: - 30°C-- 70°C
- 5) Relative humidity: < 90 % ( 25 )
- 6) Max Coordinate number: 3
- 7) Readout allowable input signal: TTL square wave
- 8) Allowable input signal frequency: < 5 M Hz
- 9) Max resolution of digital display length: 0.01 um
- 10) Max resolution of digital display angle: 0.0001 / PULSE

### 3. Instructions

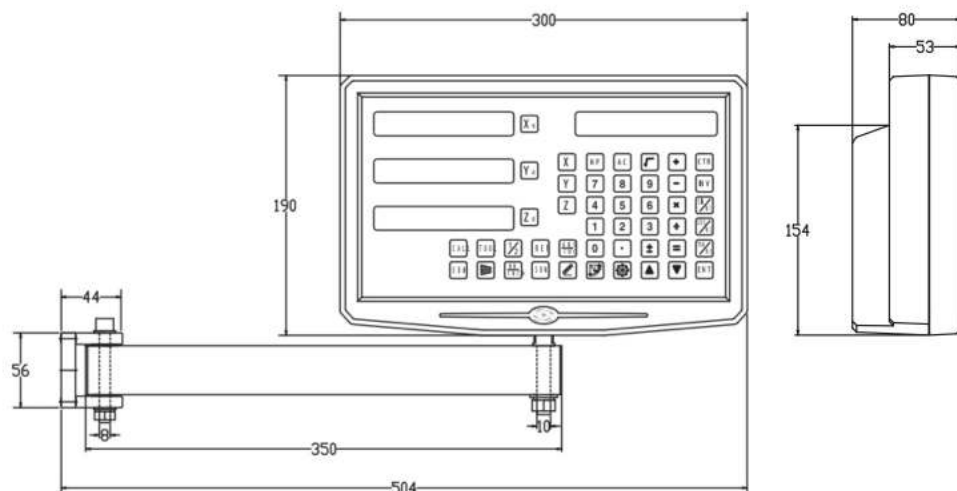

## 4. Examples of character output at the data interface

## 1、 X,Y,Z Axis

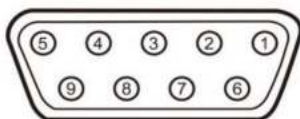

Pin	TTL (Standard)
1	
2	0V
3	
4	
5	
6	A+
7	5V
8	B+
9	R+

Pin	TTL (Standard)
1	5V
2	0V
3	A+
4	B+
5	R+
6	
7	
8	
9	

For your convenience,  
If you buy a digital readout,

The wiring definition of your linear scale must be the same as the 2 definitions in the above diagram to be universal!



## TTL signal Output:

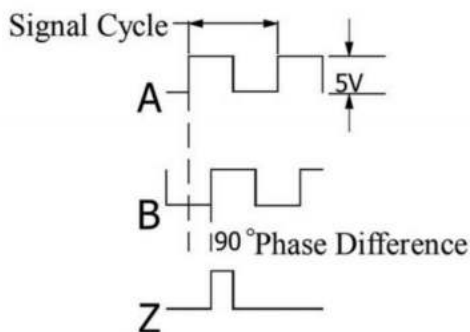

## EIA-422-A signal Output:

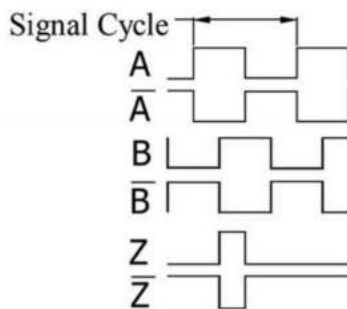

## 1. TECHNICAL PARAMETER

1.1 SCALING DISTANCE: 0.02 MM (50LINES /MM)

1.2 RESOLUTION: 5 $\mu$ M、1 $\mu$ M、0.5 $\mu$ M1.3 PRECISION:  $\pm 3\mu$ M、 $\pm 5\mu$ M、 $\pm 15\mu$ M/M (20 $\pm$ 0.1°C)

1.4 MEASURING RANGE: 30~3000MM

1.5 MOVING SPEED: HIGH-SPEED ENCODER 120 M/MIN (TO BE CUSTOMIZED)

ORDINARY ENCODER 60M/MIN

1.6 POWER SUPPLY: +5V $\pm$ 5%、80MA

1.7 CABLE LENGTH: STANDARD 3M (SPECIAL LENGTH AVAILABLE ACCORDING TO THE USER'S NEEDS)☒

1.8 WORKING TEMPERATURE: 0~45°C

1.9 PIN DESCRIPTION:

1) APPLICABLE TO: 9 PIN SOCKET EIA-422-A SIGNAL OUTPUT.

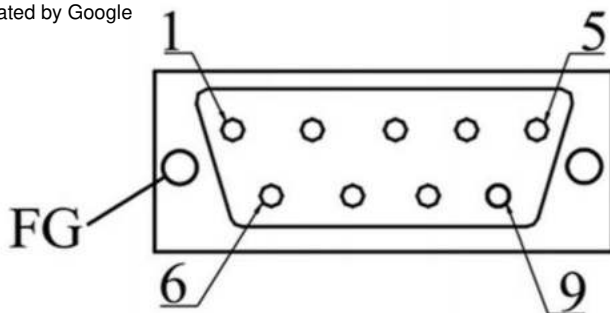

1) Applicable to: 9 pin socket EIA-422-A signal Output.

Pin Position	1	2	3	4	5	6	7	8	9
Signal	$\bar{A}$	$OV$	$\bar{B}$	Empty	$\bar{Z}$	$A$	+5V	$B$	$Z$
Color	Green Black	Black	Orange black	FG	White black	Green	Red	White	Orange

FG: Shield connected to metal casing.

1) Applicable to: 9 pin socket TTL signal Output.

Pin Position	1	2	3	4	5	6	7	8	9
Signal		$OV$		Empty		$A$	+5V	$B$	$Z$
Color		Black		FG		Green	Red	Orange	White

FG: Shield connected to metal casing.

# Linjär skala

## Installationsritningar

# Installationsmetod:

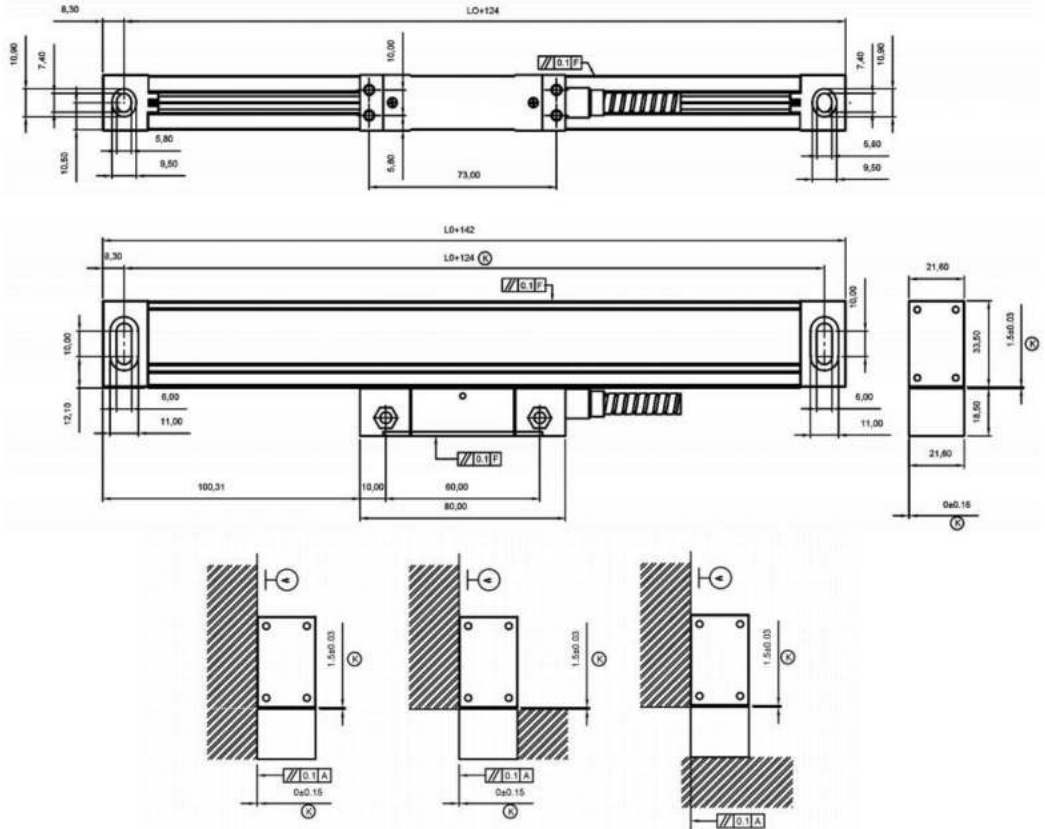

Standardstorlek: (Enhet:mm)

Modell	DET	L1	L2	Modell	L0	L1	L2
YE-50	50	174	190	YE-550 550		674	690
YE-100	100	224	240	YE-600	600	724	740
YE-150	150	274	290	YE-650 650		774	790
YE-200 200		324	340	YE-700 700		824	840
YE-250 250		374	390	YE-750	750	874	890
YE-300 300		424	440	YE-800	800	924	940
YE-350 350		474	490	YE-850 850		974	990
YE-400 400		524	540	YE-900	900	1024	1040
YE-450 450		574	590	YE-950 950		1074	1090
YE-500 500		624	640	YE-1000 1000		1124	1140

L0: Effektiv mätlängd för linjärgivaren; L1: Längd på linjär givare monteringshål; L2: Linjär givare total längd

## Underhåll:

1. Den effektiva rörelsen för linjärgivaren bör vara längre än max rörelse av verktygsmaskinen. Om längden inte räcker, byt ut den linjära pulsgivaren med ett större slag eller lägg till ett gränsblock på maskinerna. Låshuvudets ändposition från änden av den linjära givarens kropp bör inte vara mindre än 10 mm utrymme, (se följande diagram).

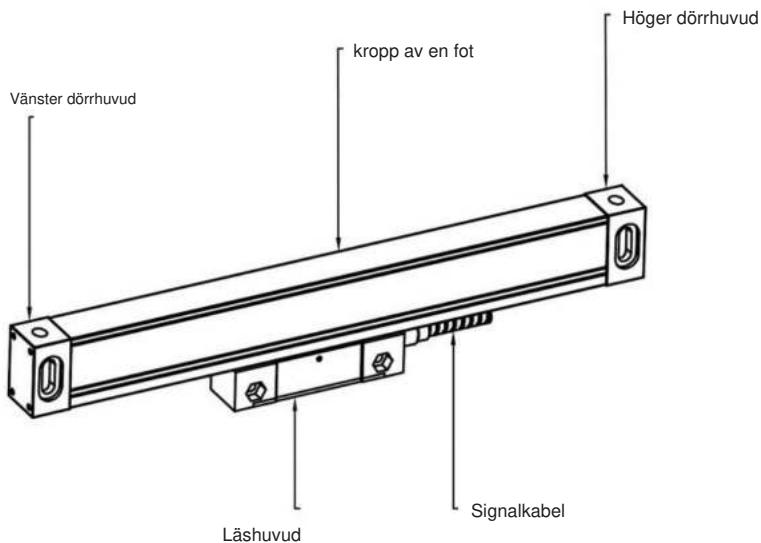

2. För alla icke-bearbetade ytor måste ett mellanlägg placeras på baksidan av den linjära omkodaren eller så måste ett användartillverkat installationsunderlägg användas för att säkerställa stabiliteten och tillförlitligheten hos anslutningen mellan gallerlinjal och monteringsyta.
3. När du använder en mätklocka eller liknande instrument för att kalibrera parallelliteten hos den linjära kodaren, måste vinkeln på sidohuvudet vara inom  $\pm 30$  grader, och ju mindre vinkeln är, desto bättre.

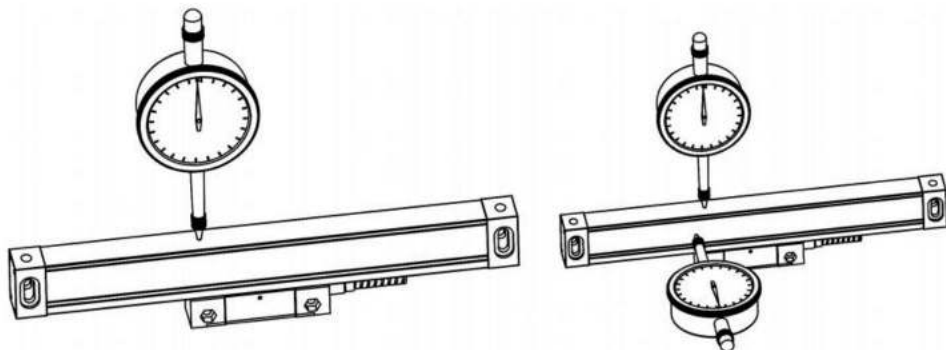

4. Installationspositionen för linjärgivaren måste undvika direkta stötar från järn fil, olja, vatten och damm (som visas i bilden nedan). Installationslängden av L-plattan bör vara så kort som möjligt under möjliga omständigheter, och monteringsytans kraftsituation måste beaktas.

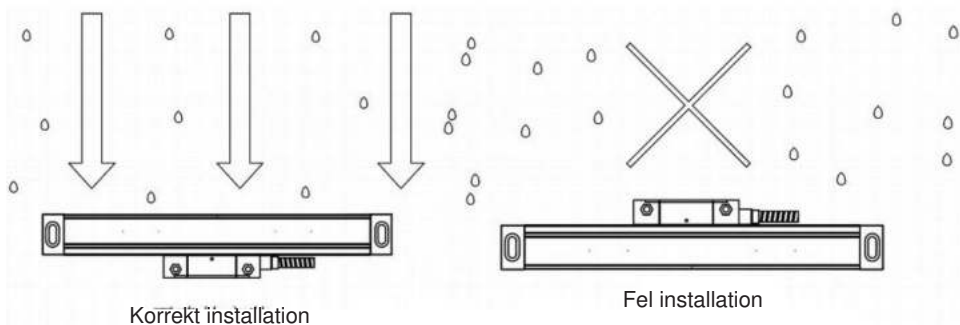

5. Det måste finnas ett mellanrum på 0,5 mm eller mer mellan dammskyddet och linjalens kropp, och undvik kontakt mellan dammskyddet och linjalens kropp när flytta läshuvudet (enligt nedan).

6. Installationsskruvens gängdjup, minst måste ha 6 tänder med låsdyb; kraft större del, såsom att stödja den digitala displayen mätare hyllan fast platta, måste ha 8 tänder låsningdjup; YE serie av skala, djupet av tråden djupet på låsdyb. Som att stödja den digitala displayen mätare hyllan fast platta, måste ha mer än 8 tänder låsdyb; YE serieskala Med M4 skruvar monterad monteringsyta gängning efter ytgradning, färg, fläckborttagning. (Följande bild)

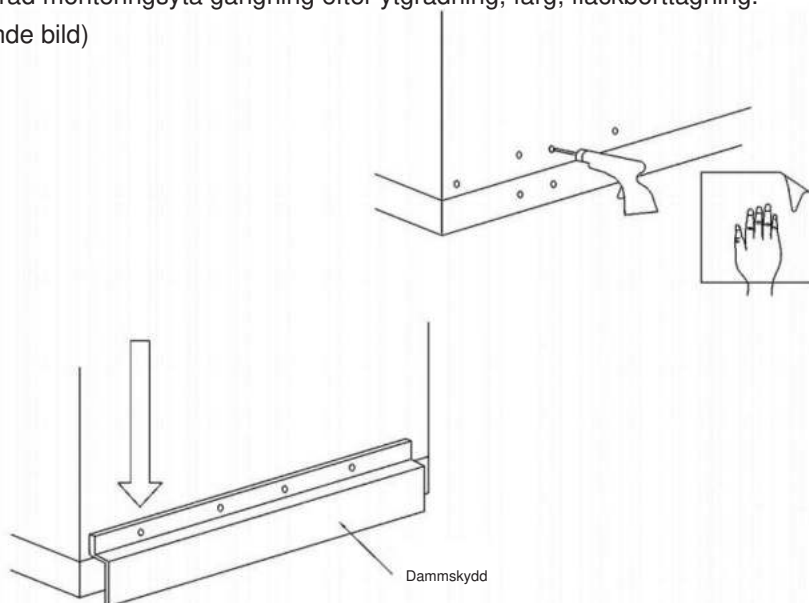

7. Fixeringen av signalledningen måste ta hänsyn till alla relevanta rörelseavstånd.  
Fixeringsposition så långt som möjligt placerad i mitten av slaget, och överskottssignalledningen fixeras med en wire tie.
8. Justering av skalans höjdnivå måste vara längden på skalans centrum för att ta de två sidorna av symmetripunkten. Justera referenspunkten, vilken skala som helst oavsett skolnivåns riktning eller höjdriktning, justeringsområde: för skalan kropp, till huvudet från vågkroppen på ett avstånd av högst 20 mm från varje ände ska råda. För läshuvudet, mellan de två fyrsidiga referensytorna (följande bild)

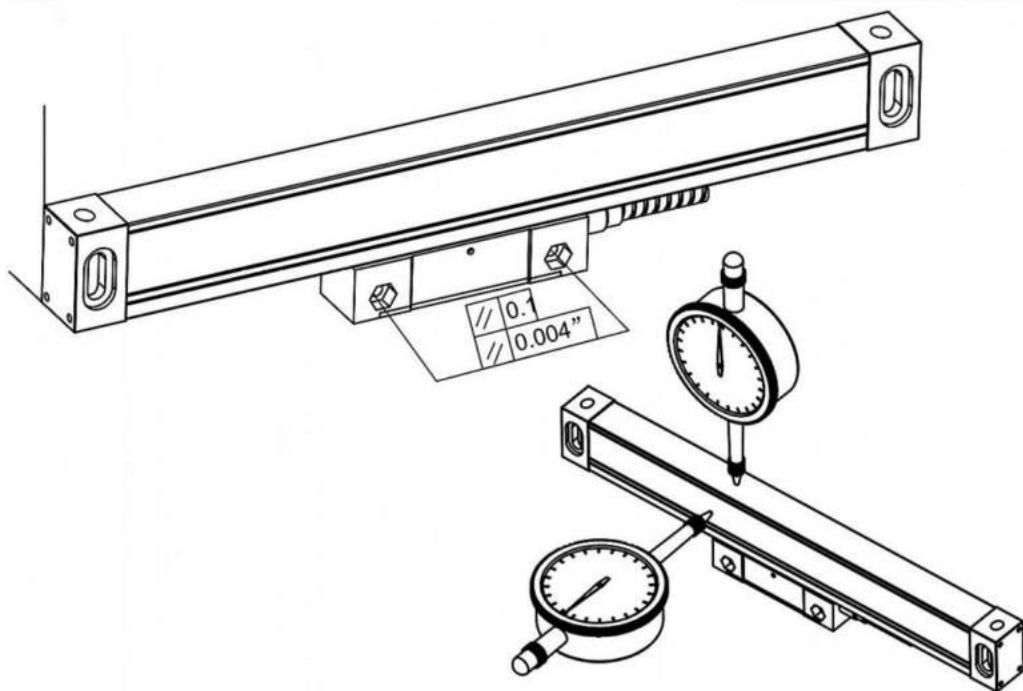

9. Böjningsradien för vågens signallinje är större än 60 mm.

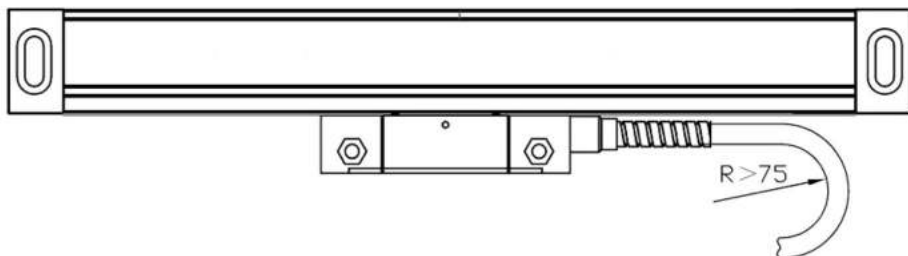

(1) Ytstandard för installationsbas (Figur 4.8abc tre installationsmetoder)

1. Linjalkroppens installationsyta är parallell med läshuvudets installationsyta och parallelliteten mellan installationsytorna är  $<0,1$  mm

2. Linjalkroppens installationsyta är vinkelrät mot installationen läshuvudets yta, och vinkelrätheten mellan installationsytorna är  $<0,1$  mm

2) Installationsstandarder för linjalkropp (Figur 4.9, Figur 4.10)

1. Höjdriktning i förhållande till maskinstyrningens parallellitet  $<0,1$  mm, max inte mer än 0,15 mm När det gäller symmetripunkten, ju mindre desto bättre.

3) Standard för installation av läshuvud

1. Spelet mellan läshuvudet och linjalkroppens höjdriktning är 0,8 mm-1,6 mm efter installation, och dra sedan tillbaka dynblocket (Figur 4.11)

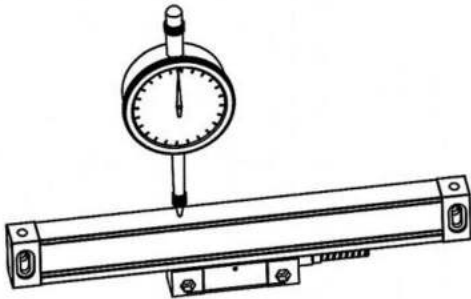

4.9

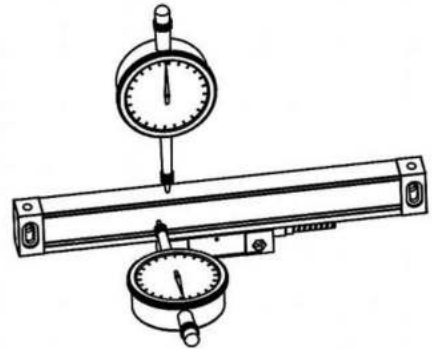

4.10

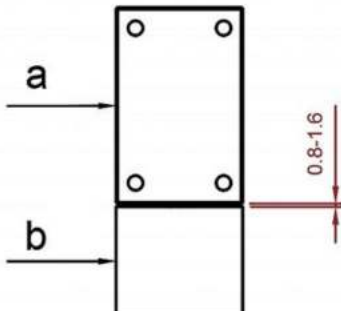

2. Läshuvud a sida och linjalkropp B sida.

Felinriktning i horisontell riktning.

$0,25 \pm 0,15$  mm

3. Parallellism av läshuvud i förhållande till

verktygsmaskin  $<0,10$  mm, maximalt får inte överstiga 0,30 mm

**Parameter:**

<b>Modle</b>	SNS-3V-YE102024	SNS-3V-YE161838
<b>Rated voltage:</b>	AC85-230V 50Hz/60Hz	
<b>Resolution</b>	5 $\mu$ m	
<b>Number of axes</b>	3	
<b>Range</b>	10 inches 20 inches 24 inches	16 inches 18 inches 38 inches

**Standardtillbehör:**

<b>Accessories for digital display meters:</b>	<b>Accessories for grating ruler:</b>
<ol style="list-style-type: none"> <li>1. Support rod * 1</li> <li>2. Knife holder plate * 1</li> <li>3. Transparent watch case * 1</li> <li>4. Power cord * 1</li> <li>5. Watch holder * 1</li> <li>6. Butterfly piece * 2</li> <li>7. M8 * 70 screw * 1</li> <li>8. M10 * 55 screw * 1</li> <li>9. Nut M10 * 1</li> <li>10. Nut M8 * 1</li> <li>11. Nut M5 * 1</li> <li>12. Internal hexagonal screw M5 * 20 * 2</li> <li>13. Internal hexagonal screw M5 * 25 * 1</li> <li>14. M4 * hex socket screw * 4</li> <li>15. M5 * 10 machine meter screws * 2</li> <li>16. Washer <math>\phi</math> 10 * 1</li> <li>17. Washer <math>\phi</math> 8 * 1</li> <li>18. Washer <math>\phi</math> 5 * 1</li> <li>19. Rubber washer 20 * 10 * 1 * 1</li> <li>20. Rubber washer 20 * 10 * 0.5 * 1</li> <li>21. Spring washer <math>\phi</math> 10 * 1</li> <li>22. Spring washer <math>\phi</math> 8 * 1</li> <li>23. Spring washer <math>\phi</math> 5 * 1</li> </ol>	<ol style="list-style-type: none"> <li>1. Ruler cover * 3</li> <li>2. L mounting plate * 4</li> <li>3. Plug * 6</li> <li>4. Screw pack * 3 bags</li> </ol> <p>Each bag contains:</p> <p>Internal hexagonal screw M4 * 30 * 4;  Internal hexagonal screw M4 * 12 * 2;  Internal hexagonal screw M4 * 8 * 4;  U-shaped gasket T=0.2mm * 2;  Washer <math>\phi</math> 6 * 2;  Washer <math>\phi</math> 5 * 2;  Washer <math>\phi</math> 4 * 6;  Line card * 2</p>

Denna enhet uppfyller del 15 av FCC-reglerna. Driften är föremål för följande två villkor: (1) Den här enheten får inte orsaka skadliga störningar och (2) den här enheten måste acceptera alla mottagna störningar, inklusive störningar som kan orsaka oönskad funktion.

**Tillverkare:** Shanghaimuxinmuyeyouxiangongsi

**Adress:** Shuangchenglu 803nong11hao1602A-1609shi, baoshanqu,  
shanghai 200000 CN.

**Importerad till AUS:** SIHAO PTY LTD, 1 ROKEVA STREETEASTWOOD NSW  
2122 Australien

**Importerad till USA:** Sanven Technology Ltd., Suite 250, 9166 Anaheim Place,  
Rancho Cucamonga, CA 91730



E-CrossStu GmbH

Mainzer Landstr.69, 60329 Frankfurt am Main.



YH CONSULTING LIMITED.

C/O YH Consulting Limited Office 147, Centurion House,  
London Road, Staines-upon-Thames, Surrey, TW18 4AX

**VEVOR**<sup>®</sup>  
TOUGH TOOLS, HALF PRICE

Teknisk support och e-garanticertifikat  
[www.vevor.com/support](http://www.vevor.com/support)