

SHARE3DCAM S30 SE

User Manual V1.0

2026.04

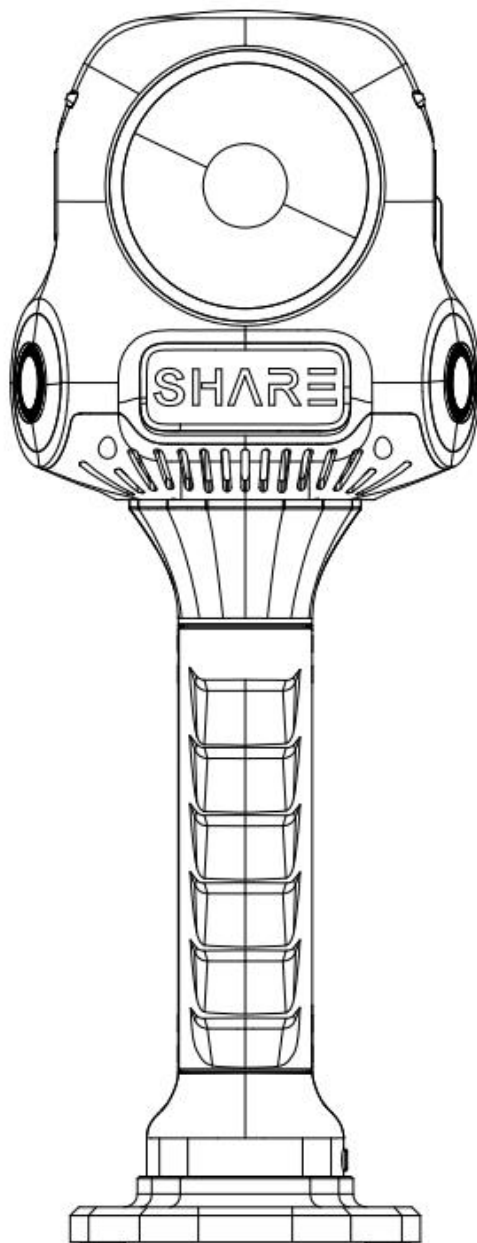

SHARE3DCAM LIMITED

Disclaimer and Warning

The copyright of this document and all other collateral documents belong to SHARE3DCAM LIMITED (abbreviated as “SHARE3DCAM ”). SHARE3DCAM has the final interpretation right of this document and all other collateral documents.

By using SHARE3DCAM products, user agree to SHARE3DCAM 's relevant disclaimer terms

SHARE3DCAM has right to update, modify or terminate the content of this document without prior notice. For update information, visit website “www.SHARE3DCAM.com” and click on the product page for this product.

This product is not a toy. Do not allow people under the age of 18 to touch or use the SHARE3DCAM S30 PRO handheld LiDAR device .

Do not modify or disassemble the SHARE3DCAM S30 PRO handheld LiDAR device. The user shall bear full responsibility for any product malfunctions, safety incidents, or economic losses resulting from self-disassembly, modification, or alteration of the product.

Please read and understand the operating documents and precautions carefully before installing, setting up and using this product, and understand user's legal rights, responsibilities and safety instructions; otherwise, SHARE3DCAM has the right to exempt itself from any responsibility and incidental liability for safety issues and property losses caused by failure to accurately

understand the product safety use rules. Before using the product, users have promised to be responsible for their own actions and all consequences arising therefrom.

The user agrees to use this product for legitimate purposes and accepts these terms and all applicable laws and regulations established by national authorities pertaining to this product.

To the maximum extent permitted by law, in no case shall SHARE3DCAM be liable for any indirect, consequential, punitive, incidental, special or punitive damages, including liability for losses suffered due to user's purchase, use or inability to use this product (even if SHARE3DCAM has been informed of the possibility of such loss).

Please use this product in compliance with the relevant national laws and regulations on drones and related products. SHARE3DCAM does not assume any responsibility for any consequences of using this product in violation of relevant national laws and regulations, including but not limited to legal disputes, civil liability, criminal liability, economic losses, etc.

Catalog

1 Product Overview	1
1.1 Product Introduction.....	1
1.2 Features	1
1.3 In the Box	2
1.4 Product Parameter.....	3
2 Installation	6
2.1 Device Components	6
2.2 Installation	6
2.3 Disassembly.....	8
2.4 Charge	9
3 Scanning Operation	10
3.1 Power On	12
3.2 Device Starting Up.....	13
3.3 Device Connect Mobile APP.....	13
3.4 Start Scanning	16
3.5 Parameter Setting	16
3.6 New Project.....	17
3.7 Control Point Collection	20

3.8 Data Collection	22
3.9 Data Saving.....	24
3.10 Power Off	25
4 SHARE Capture Data Manager.....	26
4.1 Data Storage.....	26
4.2 Local	28
4.3 Review Data	29
5 SHARE PointClouds Studio	30
5.1 Software Configuration Requirements	30
5.2 Data Processing.....	31
6 Device Maintenance	34
6.1 Precaution.....	34
7 After Sales.....	36
7.1 Shipment	36
7.2 After-sales Service.....	37

1 Product Overview

1.1 Product Introduction

SHARE3DCAM S30 SE is a handheld 3D LiDAR scanner designed and developed by SHARE3DCAM. It integrates high-precision LiDAR, surveying and mapping wide-angle camera. It deeply integrates LiDAR and image, and cooperates with self-developed point cloud algorithm. Single person operation can obtain accurate color point cloud data by scanning with a SHARE3DCAM S30 SE, which complete spatial mapping in a short time. Whether they are architectural designers, construction workers or surveying professionals, they can quickly obtain real-scene 3D information by using SHARE3DCAM S30 SE.

1.2 Features

- * Supports real-time calculation and post-processing calculation, and adds color to point clouds in real time. The appearance of color point cloud is industry-leading.
- * The point cloud thickness is within 1 cm, and relative accuracy can reach 1 cm.

- * Two 1/2-inch ultra-wide-angle cameras with electronic shutter, totaling 16 megapixels.
- * The quick-release structure of the battery makes the installation more secure. Easy and quick to operate
- * Standard “SHARE Capture” APP, real-time feedback on data collection status, real-time preview of color point cloud.
- * Standard SHARE PointClouds Studio software can generate color point clouds with one-click and the results could be generated in a variety of common formats.
- * Standard magnetic mobile phone holder, mobile phones could be more firmly adsorbed and more convenient to use.
- * Connect to WiFi with one-click encryption via Bluetooth, making the WiFi connection more stable.

1.3 In the Box

Item	Main Unit	Grip Battery	Charger	Position Plate	Card Reader
QTY	1PC	1 PC	1 PC	1 PC	1 PC
Item	Wipe Cloth	Warranty Card	User Manual	Data Cable	Phone Holder
QTY	1PC	1 PC	1 PC	1 PC	1 PC

1.4 Product Parameter

SHARE3DCAM S30 SE Parameter		
Basics	Weight	Main Unit: 870g Grip Battery: 390g Overall: 1260g
	Protection Class	IP5X
	Working Temperature	-20°C~+50°C
	Storage Temperature	-20°C~+60°C
	WIFI	WIFI 6, Support 2.4G/5G 802.11 a/b/g/n/ac/ax Wi-Fi 2.4G: 2.400 ~ 2.4835 GHz 5G: 5.15 ~ 5.25GHz~ 5.725 ~ 5.85GHz
	WIFI Distance	20 m
	Bluetooth	Support
	Overall Dimensions	107*118*274mm
	Main Unit	107*118*112mm

	Dimensions	
	Storage Capacity	256 G(Support memory expansion)
	Supply Voltage	20 V
	Working Power	< 30 W
	Interface	TF Card / Type-C/Battery Handle Interface
	Processor Performance	8-core 64-bit processor, clock speed 2.4 GHz
LiDAR	LiDAR Class	Class 1 / 905 nm
	Point Cloud Number	1152000 points/s
	Point Cloud Frequency	10 Hz (Typical Value)
	Scanning Range	0.1 ~ 60 m; 40 m @ 10% reflectivity
	LiDAR FOV	Horizontal 95°; Vertical 360°
	LiDAR Installation	Horizontal forward
Camera	Sensor Size	7.504*5.659mm; 1/2 inch
	Pixel Size	1.6μm*1.6μm
	Image Size	2832*2832

	Effective Pixels	Single lens 8 million
	Shutter Type	Electronic shutter
	Aperture	Fixed F2.25
	Focal Length	1.4 mm
	Lens FOV	200°
Battery& Software	Battery Capacity	45.36wh (3150mAh)
	Supply Voltage	14.4V
	Working Time	100min
	Charging Port	TYPE-C
	Charging Power	PD 30W
	Charging Time	120min
	Point Cloud Thickness	≤ 1cm
	Relative Accuracy	≤ 1cm
	Absolute Accuracy	≤ 5cm

2 Installation

2.1 Device Components

The SHARE3DCAM S30 SE device is divided into two parts, main body and the grip (Includes battery and positioning board). The handle serves to power the main unit and support it during scanning; the main body includes LiDAR, lens, storage module, etc.

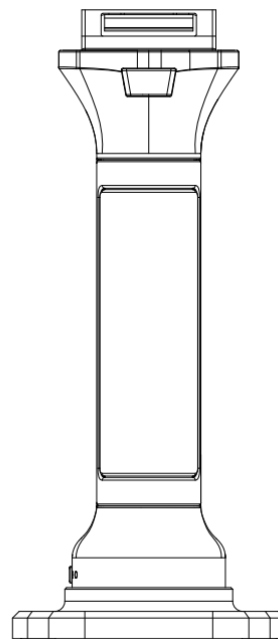
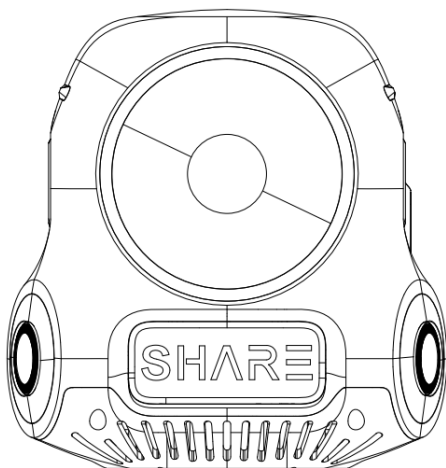

2.2 Installation

2.2.1 Install Position Plate

Align the handle buttons with the rear end of the positioning plate. Insert the bottom of the handle into the positioning

plate's retaining slot. Align the screw holes at the bottom of the grip with the 1/4 foot screws at the bottom of the positioning plate. Turn the screws to the clockwise until they are tightened. Shake slightly to confirm that the grip and position plate are secure. In order to facilitate users to measure control points, an acrylic cross transparent hole is set at the front end of the positioning plate.

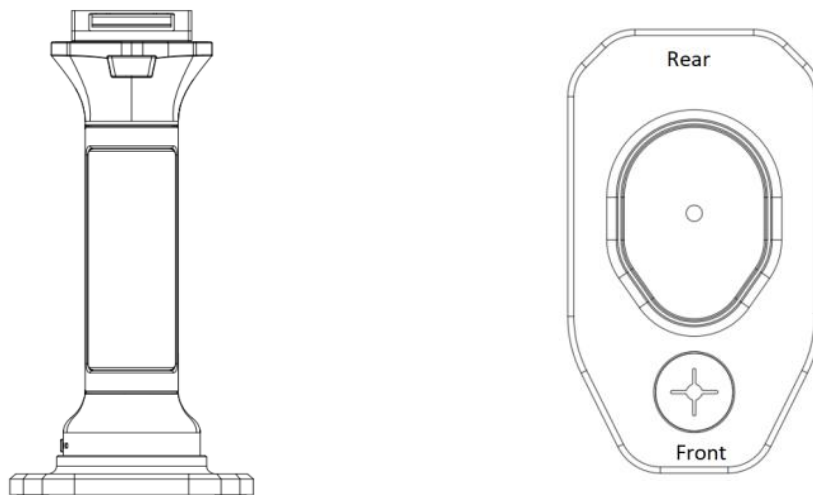

2.2.2 Install Scanner Module

Align power interface on the top of the grip battery with the power interface on the bottom of the scanner, with the magnetic ring of the scanner facing user. Gently press down on the scanner and insert it directly. A click sound indicates installation is complete. The battery grip's unlock button will eject completely once installation is complete.

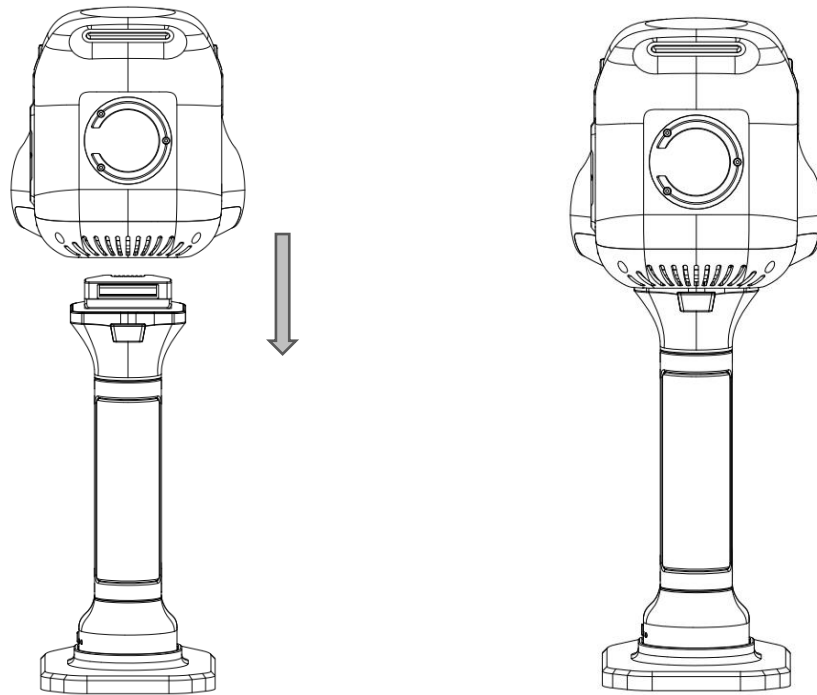

2.3 Disassembly

2.3.1 Main Unit Disassembly

Hold the handle with your left hand and the scanner with your right hand. Press the unlock button on the handle, hold the button down, and pull the scanner upward. At this time, be careful not to use excessive force to avoid bumping the device.

2.3.2 Positioning Plate Disassembly

First, make sure the grip battery and scanner have been disassembled, then pull up the 1/4 foot screws pull ring at the bottom of the positioning plate and rotate it counterclockwise

until the positioning plate and grip battery can be easily separated. This completes the disassembly.

2.4 Charge

When charging the device, it is necessary to remove the scanning module from the entire device. Take out the charging device provided in the box and insert it into the TYPE-C charging port at the bottom of the grip. Wait until the power indicator lights light up one by one, which indicates that the grip battery is charging. To protect battery life and ensure safe use, please charge the handle battery within a temperature range of 0°C to 45°C.

2.5 Check battery level

In the off state, briefly press the battery button to check the number of indicator lights that turn on. Different numbers of lights indicate different remaining battery levels. The correspondence between the number of indicator lights and battery level is shown in the table below:

Light Number	Power
Red	15%
1	15%-25%
2	25%-50%
3	50%-75%
4	75%-100%

3 Scanning Operation

When starting the scan, use the SHARE Capture App to control and monitor the device. Through this app, user can control the device to new scanning project, start scanning, end scanning, manage data, check device status and do other operations.

There is an indicator light above the scanner, which can check the working status.

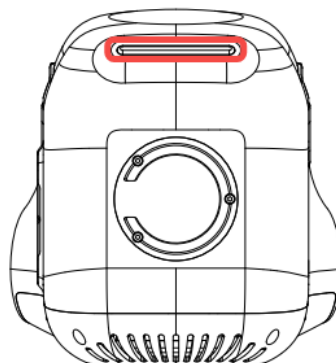

The color and corresponding status of the indicator light are as shown in the table below.

Device Status	Left	Right	Display
POST	-	-	chaser lights
Booting	-	-	rapid blue flash
Boot Completed	-	-	solid blue light
Firmware Upgrading	-	-	solid yellow light
Data Saving	-	-	slow yellow flash
Powering off	-	-	rapid yellow flash
Device Abnormality	-	-	solid red light
Starting Operation	-	-	rapid green flash
Scanning	-	-	slow green flash (Breathing Light)

The light strips on both sides of the device display when synchronously powered on.

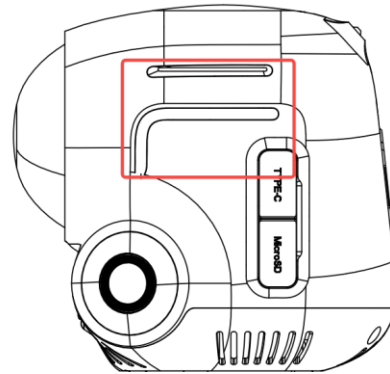
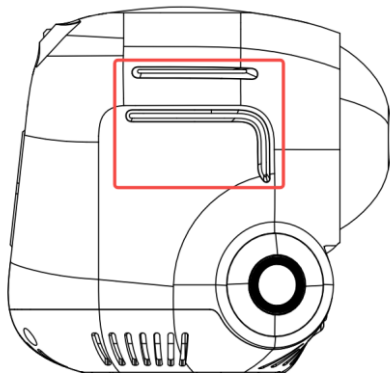

Status indication for light strips on both sides of the device:

Device Status	Light strip display
POST&Booting	Start: Light blue - Blue-white gradient - Red-white gradient - Red; End: Timed refresh
The device has been successfully powered on and is in idle state (no operation).	Front: Light blue - Blue-white gradient - Red-white gradient - Red; Back: Breathing Light
Equipment in operation	White light, steady on

3.1 Power On

Briefly press and then hold the button at the bottom of the battery. The battery indicator lights will turn on sequentially from the first to the fourth light, indicating that the device is powered on. The handle powers the device when it is turned on. When the main body is powered on, the battery indicator displays the remaining charge in real time. As the battery drains, the number of indicator lights decreases sequentially. When the battery is critically low, the first indicator light turns red.

3.2 Device Starting Up

After turning on SHARE3DCAM S30 SE, wait for about a minute for the device to start up in order to prepare for subsequent scanning. A steady blue light indicates that the device has successfully started.

3.3 Device Connect Mobile APP

Find the “SHARE Capture” app on the official website and install it. Enter the main interface of the software, enter your account and password to log in, or register and then log in.

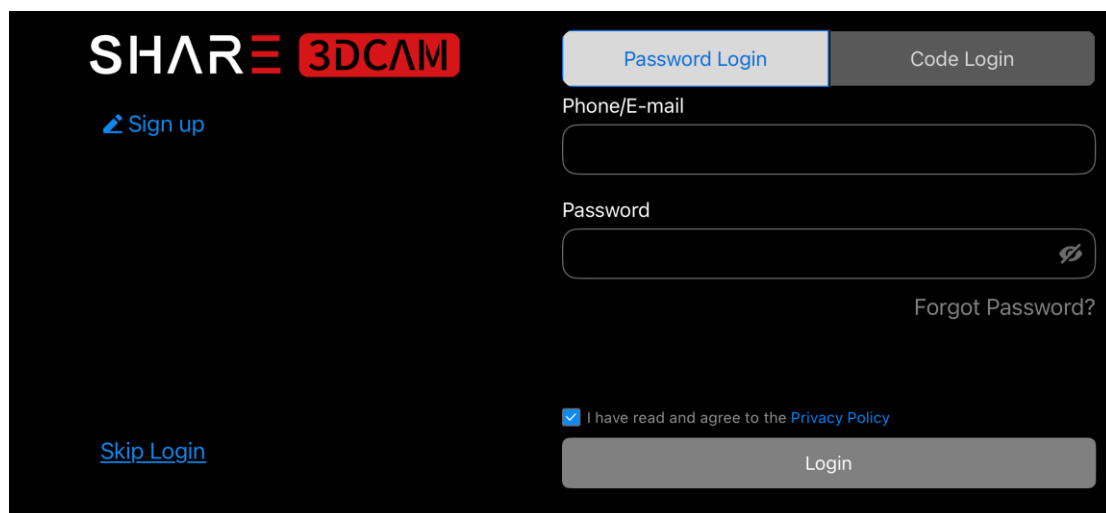

The screenshot shows the login interface for the SHARE3DCAM mobile application. At the top left is the logo 'SHARE 3DCAM' with 'SHARE' in white and '3DCAM' in white on a red background. Below the logo is a blue link 'Sign up'. In the bottom left corner is a blue link 'Skip Login'. The main area has two tabs: 'Password Login' (active) and 'Code Login'. Below the tabs are two input fields: 'Phone/E-mail' and 'Password'. The password field has a small icon on the right. Below the password field is a link 'Forgot Password?'. At the bottom, there is a checkbox with a blue checkmark and the text 'I have read and agree to the Privacy Policy', followed by a large grey 'Login' button.

3.3.1 First Time Connecting to the APP

Enter the main interface of the app. As shown in the figure below, it means that the device is not connected.

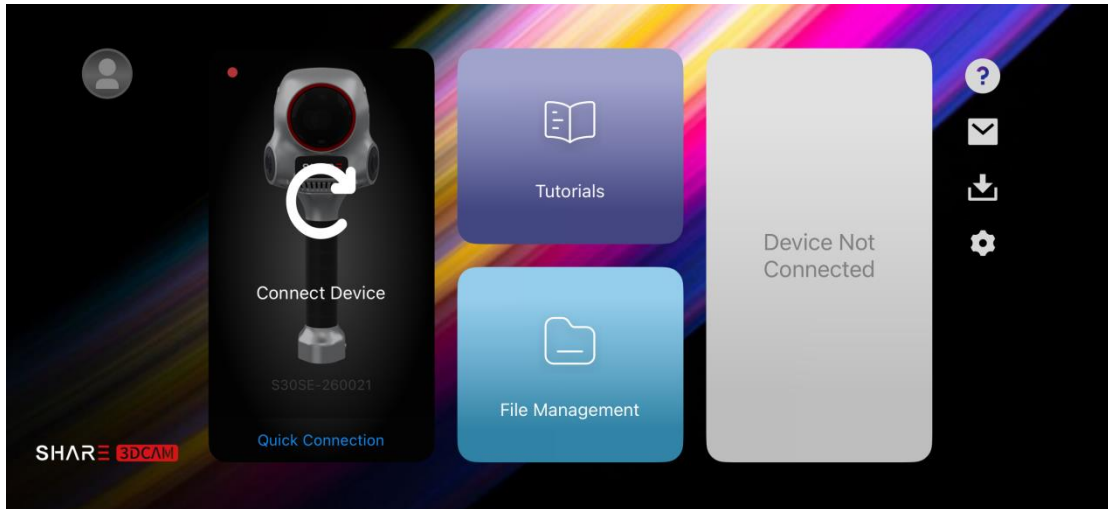

Tap “Connect Device,” then select the corresponding device SN in the pop-up device search bar and tap Connect.

(Note: When connecting a device for the first time, ensure both Wi-Fi and Bluetooth are enabled on your phone.)

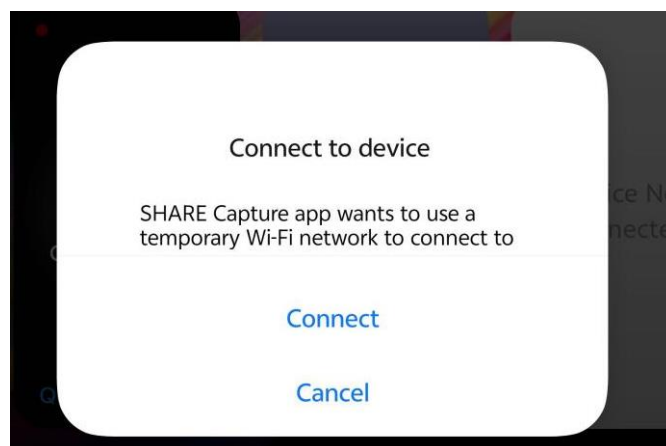
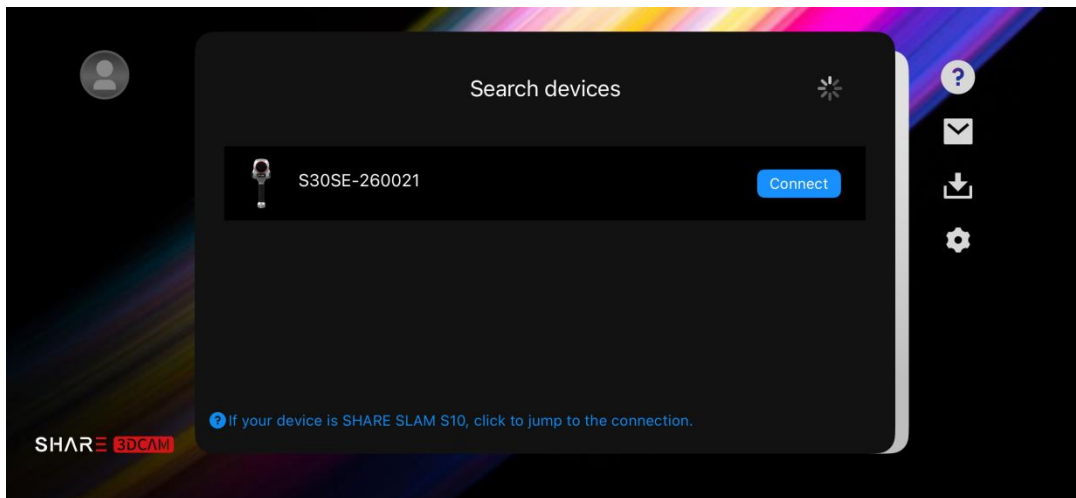

The app will then enter device connection mode. Upon successful connection, the screen will display the connected device model: SHARE3DCAM S30 SE, along with the current health status of the connected device. As shown below:

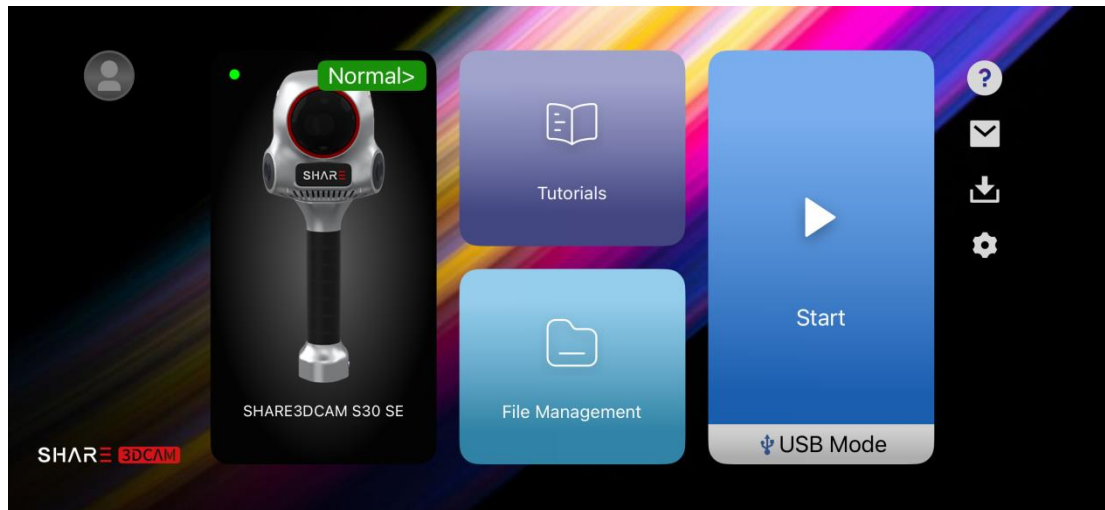

3.3.2 Device Repeatedly Connects to APP

After the device is connected to the app for the first time, the app will record the device's WIFI information. When the device needs to connect to the app next time, just click "Quick Connection" and the app will automatically connect to the device with the last SN, without having to repeatedly select the device model and SN.

Note: The device that can be repeatedly connected can only be the device that was disconnected last time.

3.4 Start Scanning

After the device is connected, click "Start " to enter the scanning interface. Users can set relevant parameters such as point cloud display, RTK, and device lighting according to their own needs before starting scanning.

3.5 Parameter Setting

3.5.1 Point Cloud Display Settings

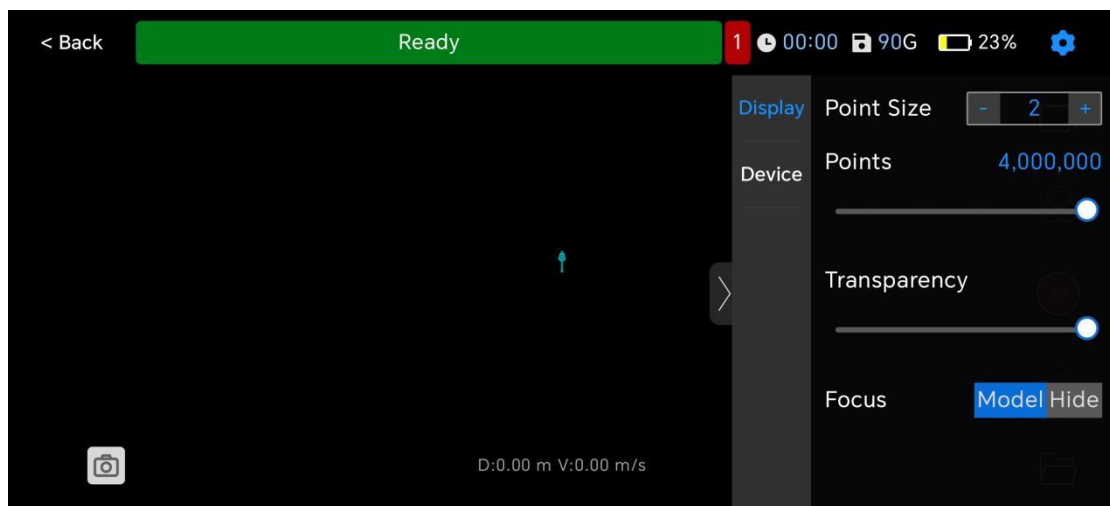

Click the setting button in the upper right corner of the APP interface to set point cloud display .

Display	Point Size	Range 1-10
	Point Number	The maximum value can be set to 4 million
	Transparency	0-100 Transparency

	Focus	Users can switch handheld device Model or Hide, Can display the current device location
--	-------	---

3.5.2 Device Settings

By toggling the lighting switch on the device, you can control the illumination of the light strips on both sides of the device.

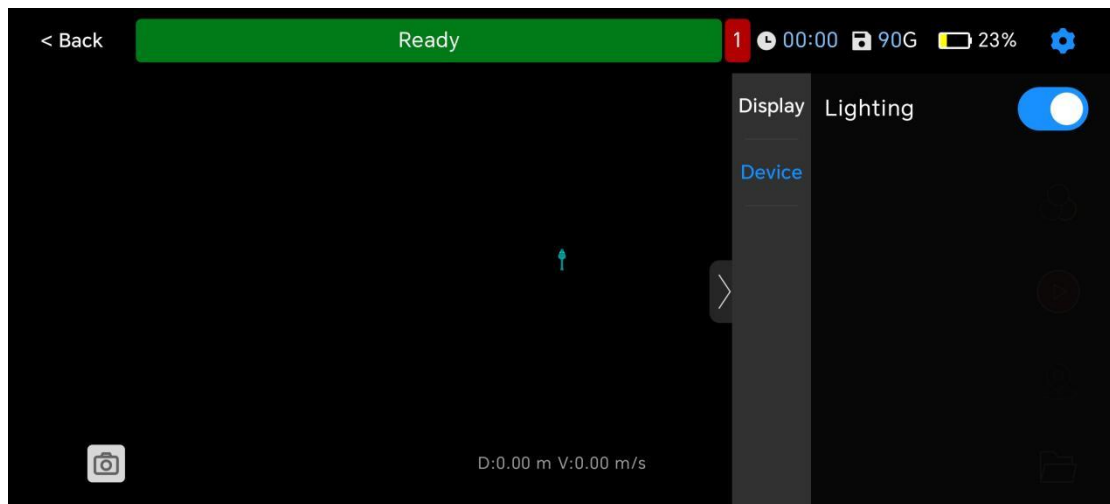

3.6 New Project

When the device status shows "Ready", user can click the "Start" button on the right to start the project. A pop-up window will appear. On the left side of the pop-up window is "Pre-Work Inspection", which includes HMS(Health Management System), RTK status, battery status, and storage left. On the right side of the pop-up window is "Create New

Project". It includes two acquisition modes: point cloud and Gaussian. Before starting the operation, user can set the project name and the camera shooting time interval. The Gaussian sampling mode does not allow for setting the time interval. Click "Next" and the device will start working.

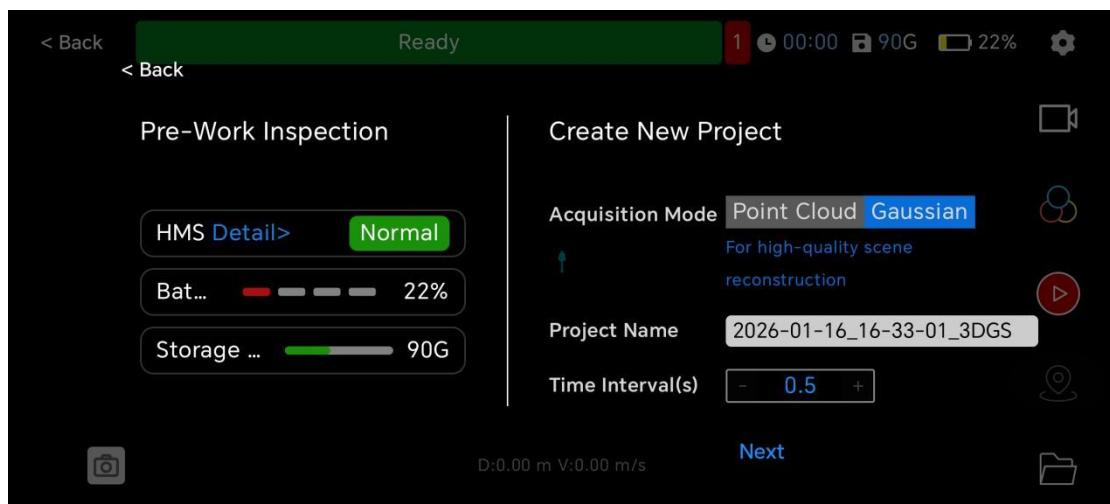
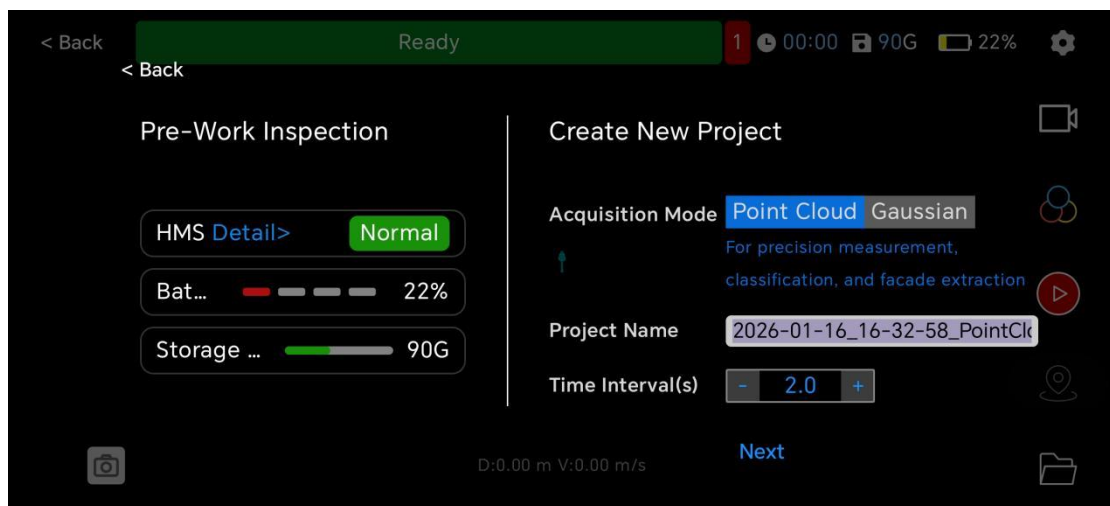

3.6.1 HMS(Health Management System)

Before creating a new project, user can view the details of the HMS. Click on the "Detail" to see the status of each part. It is

divided into 6 major parts, including the MCS (main control system), Main Camera, LiDAR System, Battery System, and Storage System.

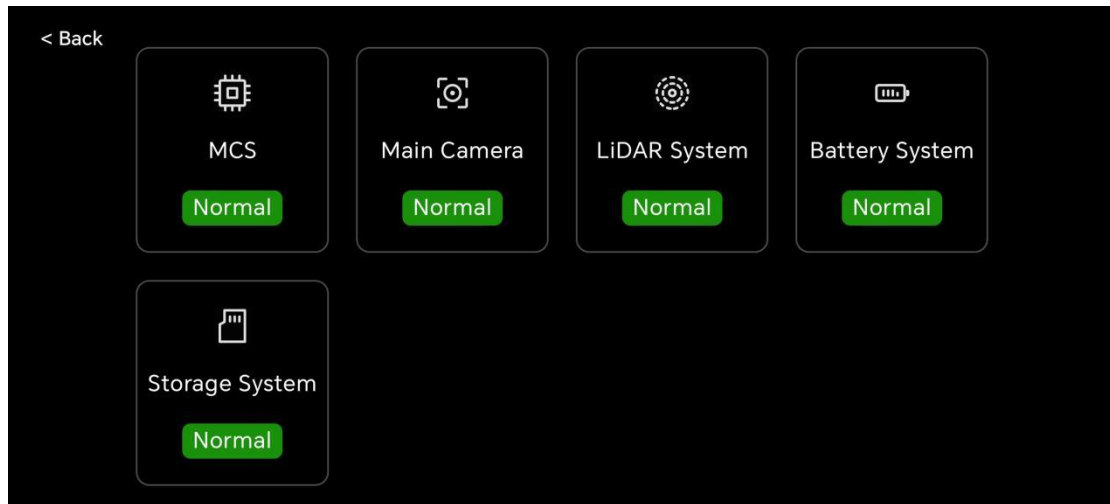

Click the "MCS" to view it, and the following interface will pop up. The left side shows each module and its corresponding status, and the right side shows the relevant information of the corresponding module. If user switch to other modules on this page, the information on the right side will also be updated accordingly.

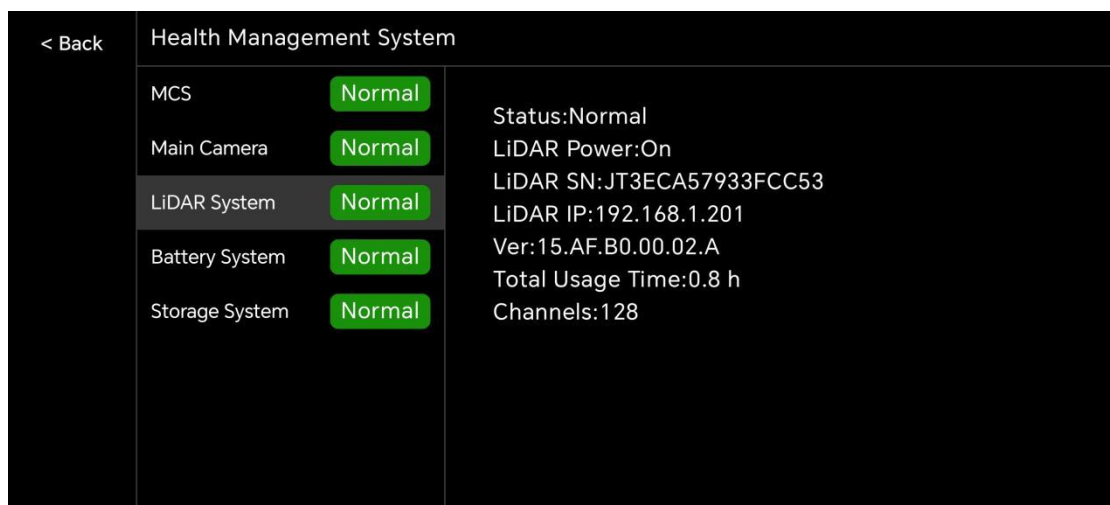

3.7 Control Point Collection

When starting the project, user can click  button on the right side of the interface to add or delete control points. After the control points participate in the point cloud processing, the point cloud results can be converted into the coordinate system of the control points.

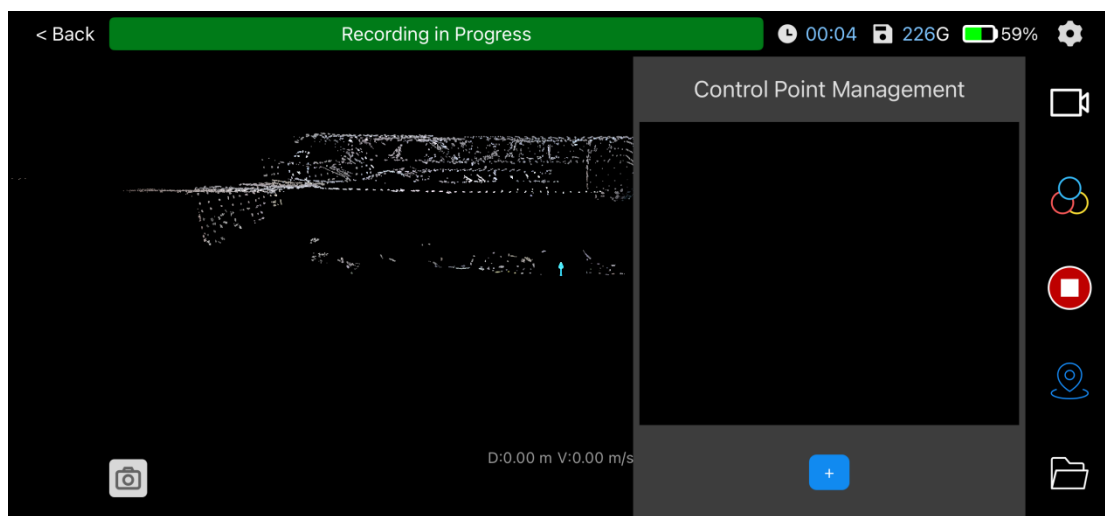

When collecting control points, user needs to align the center of the acrylic plate of the positioning plate with the control point position, and then click “Add Control Point”. Keep the device stable and complete the collection according to system prompts.

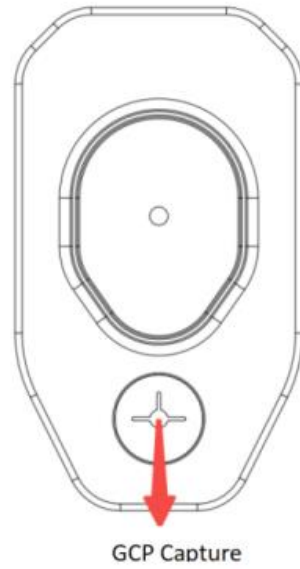

For the collected control points, users can overwrite or delete them according to their needs.

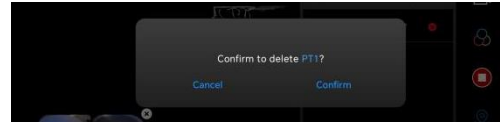
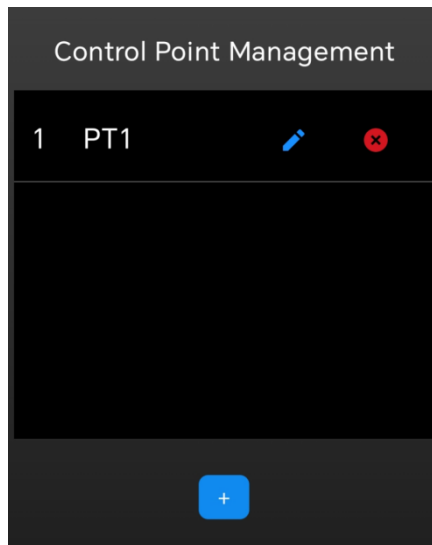

3.8 Data Collection

When the device status shows "Ready", the scanning operation can begin. The APP displays the reconstructed three-dimensional space point cloud information and collection trajectory in real time, and user can manually view the spatial three-dimensional color point cloud.

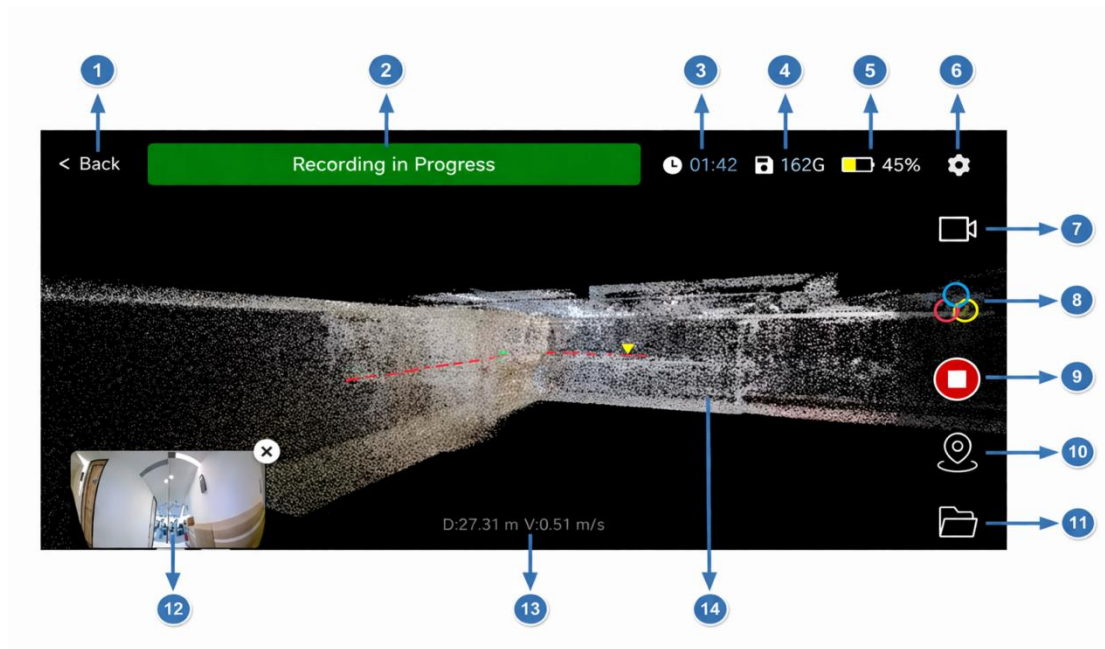

The operation interface function description is as follows:

- ① Back : Click to return to the main interface of the software;
- ② Status Description: Prompts the current status of the project;
- ③ Working Time: Prompts the working time of the current project;
- ④ Remaining Storage Space: Prompts the memory card remaining space;
- ⑤ Power: Device power description;
- ⑥ Setting: Project parameter setting, click to set relevant parameters;
- ⑦ Roaming Mode: Switch roaming modes, including free roaming and third-person;

- ⑧ Point Cloud Mode: Switch the display mode of point cloud in the three-dimensional scene, supports three modes: color point cloud, intensity coloring and elevation gradient;
- ⑨ ON/OFF: Control the start and end of project;
- ⑩ Control Point Management: Operations such as adding, deleting and covering control points of the project;
- 11 File Management: Jump to the file management page, where user can manage, delete, view and do other operations on local (save in mobile) or device project data;
- 12 Image: View image information taken by the device;
- 13 Cumulative distance/travel speed: Displays the accumulated length of data collected in the current project and the current travel speed;
- 14 Three-dimensional Scene: Display point cloud and trajectory lines, and can be manually operated to view details.

3.9 Data Saving

To end the scan, click the red button on the right side of the screen. After clicking the button, a message saying “Saved successfully” will appear in about 15 seconds. To continue scanning, please wait for the message to appear and wait for 1

minute after the message appears before performing the next scan.

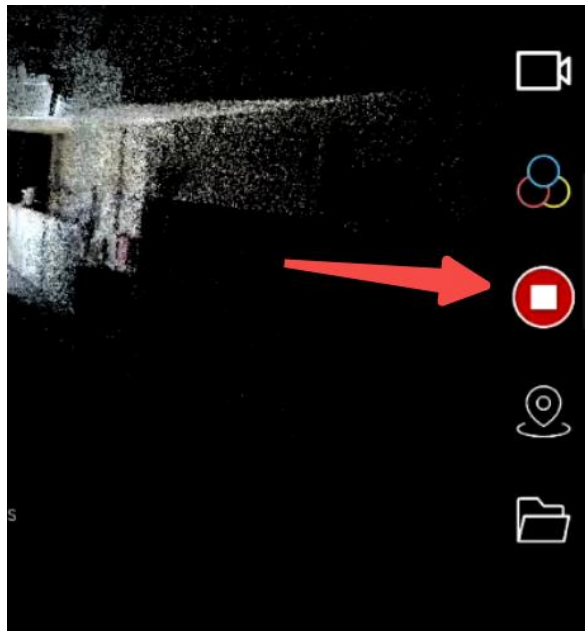

3.10 Power Off

First, make sure that the device has completed collecting data and saved it, which means the device is in a stopped working state. Short press and long press the power button on the grip battery. After about 5 seconds, the indicator light goes out, which means the device has been turned off.

4 SHARE Capture Data Manager

SHARE Capture provides various functions for data management. Users can upload, download, rename, delete and operate other functions of files through the "File Management" page. If users download data from the device to their mobile phones, they can view the data on their mobile phones.

4.1 Data Storage

Please note that although user can view the entire process of scanning data on mobile phone, after each project is done, the project data is saved in the TF card of SHARE3DCAM S30 SE. So user can find data which just scanned in the " File Management" by clicking "Device" option. The default file name is the time when scanning started.

The default preview cover is the first image when recording is started. It is recommended to use the "Rename" function to change each project to a name specified by user, so that the file can be found again later easily. The function buttons in the upper right corner are "Download", "Delete" and "Sort" from left to right. The "Sort" menu can help user sort the project by

name or size. Please note that once deleted, project data cannot be retrieved.

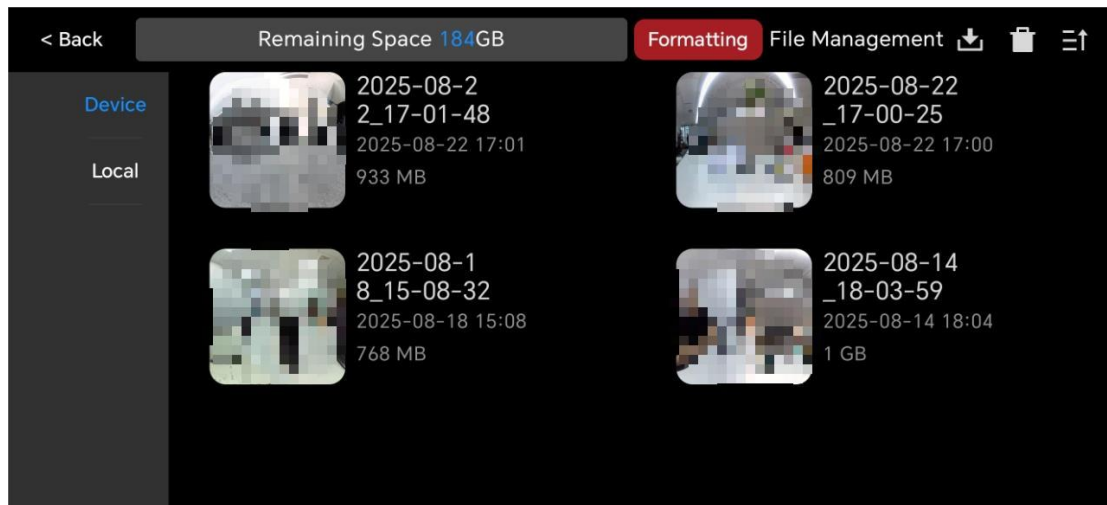

4.1.1 File Operation and Log Upload

Select a file and press 1-2 seconds to download, rename, upload logs, delete, etc. If user needs to upload the log of the corresponding project, user can click “Logs Upload” and describe the issue and the phenomenon that occurred during scanning to SHARE3DCAM.

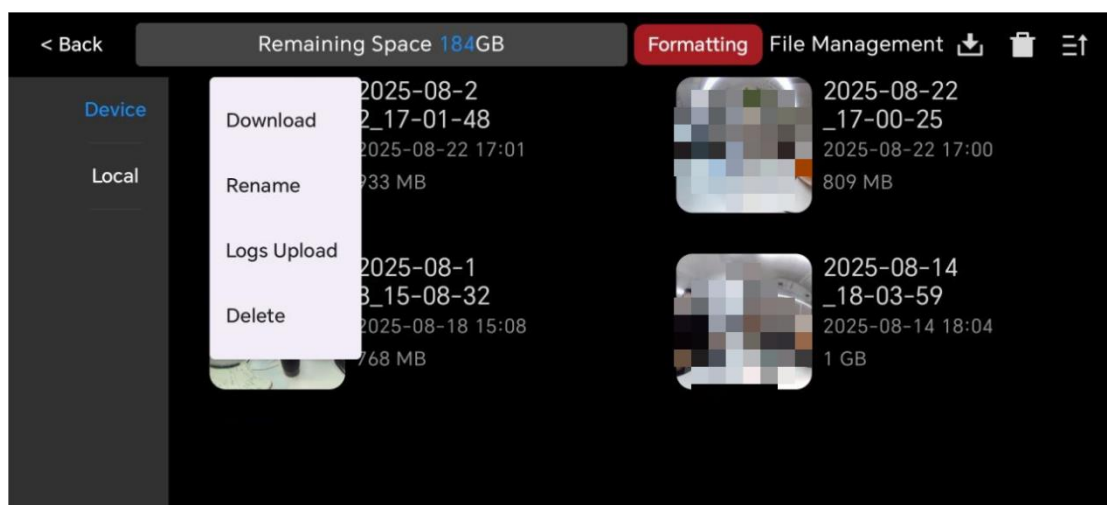

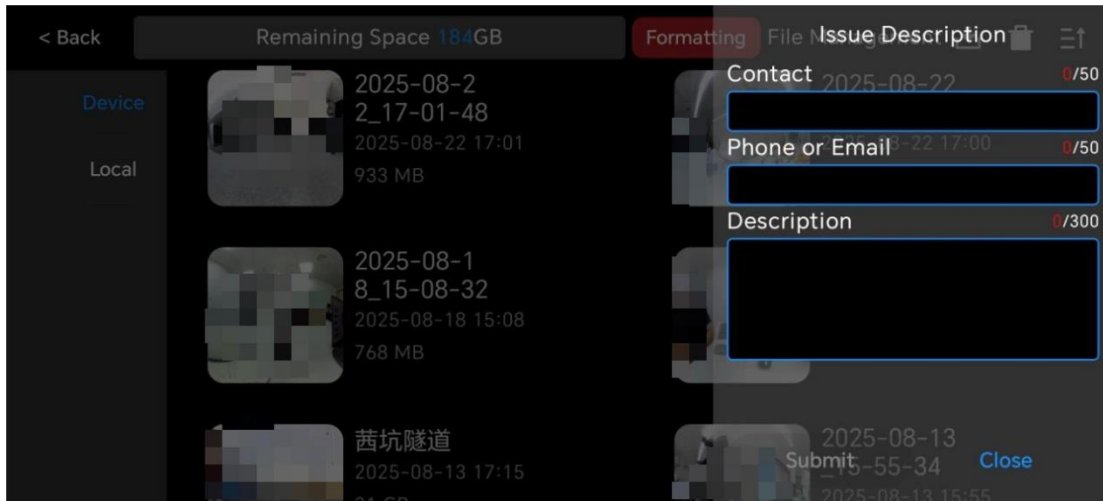

Fill in the relevant information in the "Issue Description" window and click the "Submit" button to upload the log file corresponding to the project.

Note: Only supports uploading SHARE3DCAM S30 SE device log files.

4.2 Local

If user wants to download the scanned project data to user's mobile phone, user can first click on the file user wants to download on the "Device" page, click "Download". Once the transfer reaches 100%, user can find the downloaded file in "Local" later.

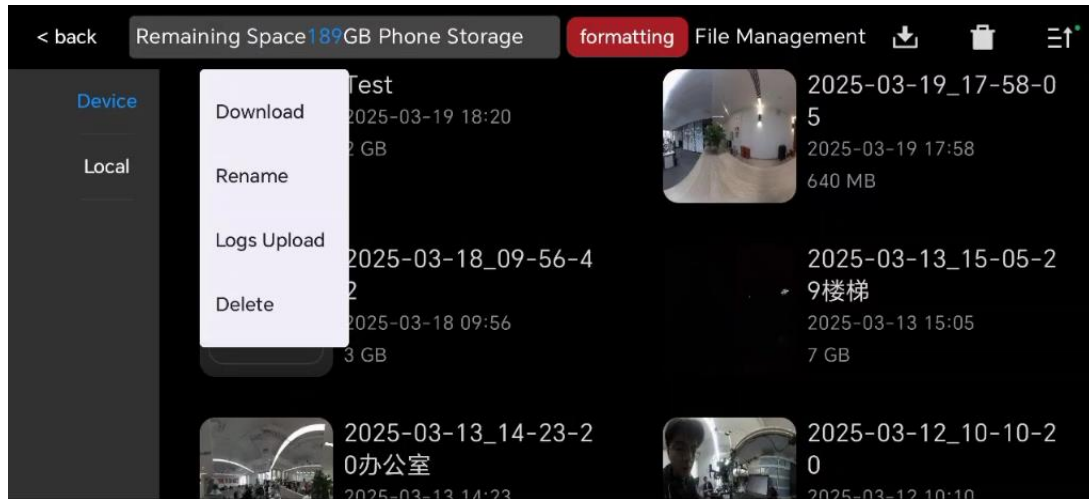

From the "Local" interface user can control movement to view the scanned area. Please note that due to the limited computing power of mobile phones, the point clouds seen in "Review" are thinned out point cloud data and are only used to help user check the area user have traveled. If user needs to see a better complete effect, user needs to post-process data in SHARE PointClouds Studio.

4.3 Review Data

Switch to "Local" file management, click on the corresponding project, and in the "Review" interface, user can rotate/zoom and pan point cloud.



5 SHARE PointClouds Studio

SHARE PointClouds Studio software is a data processing tool software designed for the SSHARE3DCAM handheld series of products. The software provides functions such as original data analysis, 3D point cloud viewing, and measurement analysis.

When matched with handheld LiDAR device, it can completely cover the entire process of data collection, data processing and data analysis, and fully supports the application of 3D LiDAR point cloud.

5.1 Software Configuration Requirements

To ensure that the software uses smoothly, the recommended configuration is as follows:

CPU	Intel® Core™ i7-10700H@2.90 GHz(Or equivalent performance processor to AMD)
GPU	GeForce RTX2060 4GB
RAM	32GB
Hard Drive Capacity	64G capacity available
Operating System	Windows 10 and above series

5.2 Data Processing

Remove TF card from device, insert it into the card reader, connect it to the computer to read the data, and copy project file (such as 2025-08-26_xxx) to the computer local disk.

Open the SHARE PointClouds Studio software, select the files to be copied from your computer, and click “OK” to begin data processing.

Set the project name, storage path, and raw data, click the “confirm” button to create the project, and enter the "Point Cloud Mapping" process for the project.

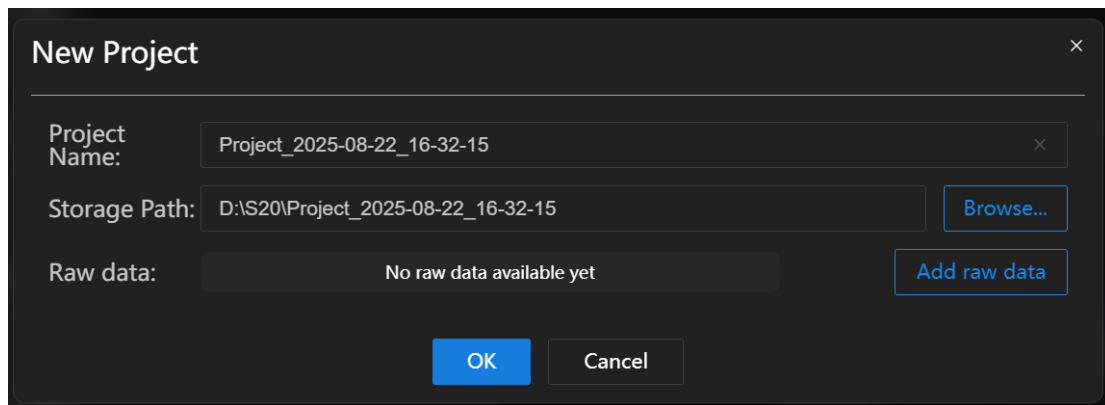

Add the original data and set the mapping parameters. After the settings are completed, click "Start the calculation" to perform the "Point Cloud Mapping" process for the project.

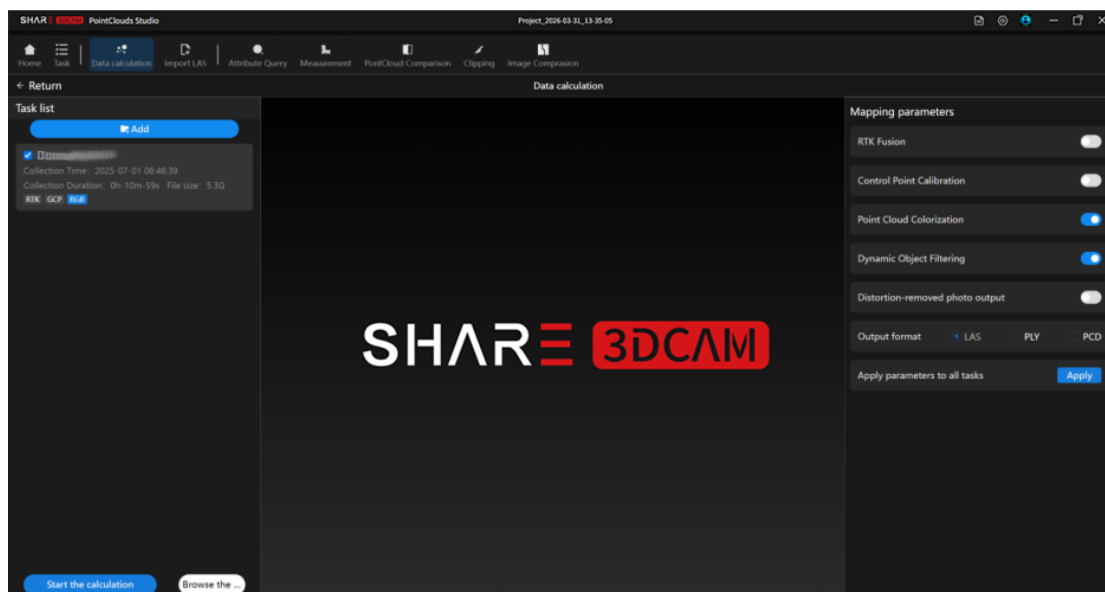

The software automatically pops up the "Task " pop-up window to view the progress of the point cloud mapping of the project.

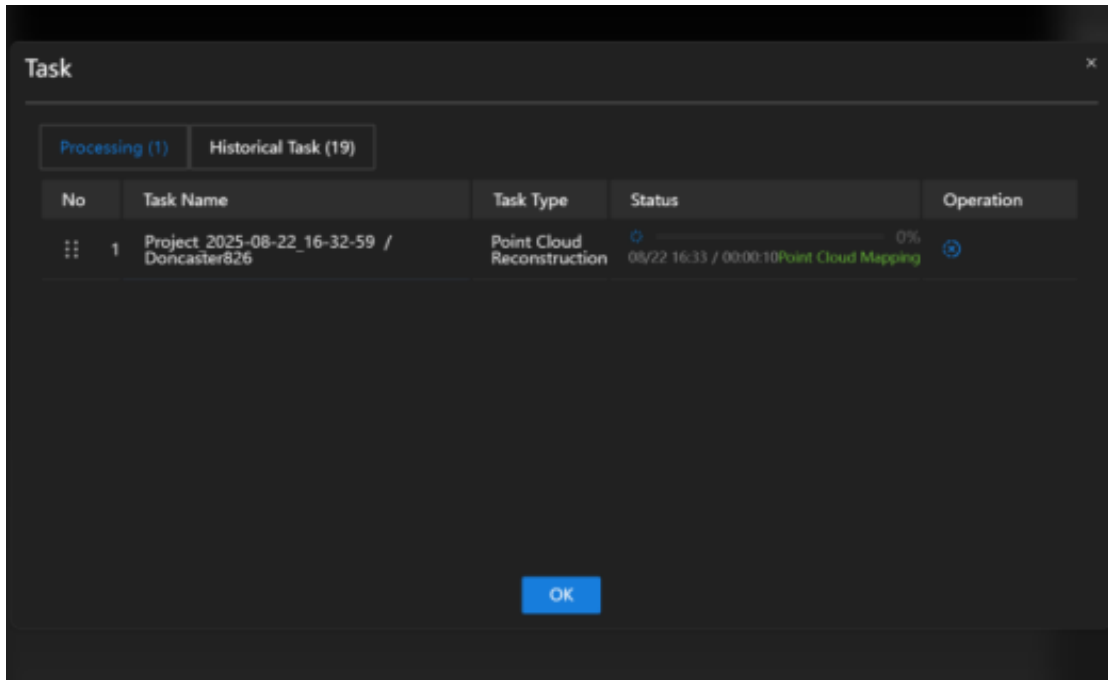

After the processing is completed, the status of the corresponding project is displayed as "Success".

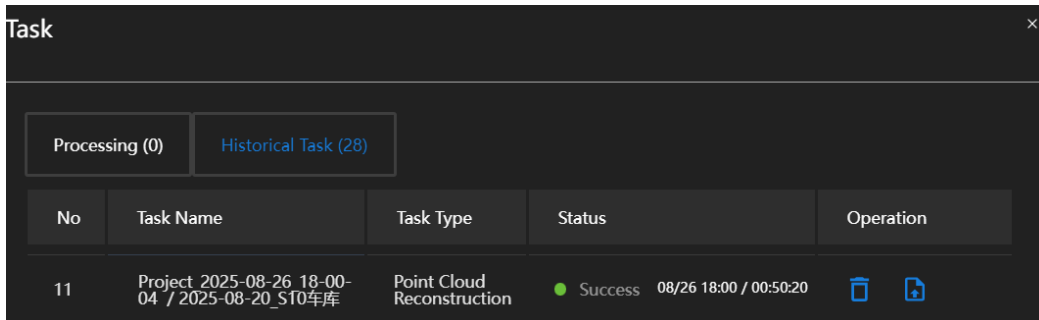

**SHARE3DCAM S30 SE
Instruction Manual**

Please scan the QR code on the right for detailed product operation instructions, including detailed software operation instructions.

6 Device Maintenance

Do not disassemble the device without permission.

Handheld LiDAR device checking and debugging have been completed before delivery. Please do not alter or dismantle the device by yourself. The consequences caused by users' unauthorized modification of the camera shall be borne by users. If user needs to design or modify the camera to install and load, please contact SHARE3DCAM technical support staff.

6.1 Precaution

1. Please store the handheld LiDAR device in a dry and ventilated place at normal temperature to avoid lens fogging caused by excessive humidity. The recommended storage environment temperature is from -20°C to 60°C . If the lens fogs up, water vapor will dissipate automatically after the handheld LiDAR Device is turned on and heat up for a period of time.

2. Avoid storing the handheld LiDAR device in a place of strong vibration and strong magnetic.
3. Avoid bringing the equipment directly from cold places to warm places to prevent moisture condensation.
4. Do not place the handheld LiDAR device in strong light for a long time.
5. Avoid scratching the lens & LiDAR surface coating by hand or hard objects.
6. Keep the handheld LiDAR device interface clean and dry.
7. When cleaning the lens, please use a soft and dry cleaning cloth to wipe. Please do not use a cleaner containing organic solvents such as thinner or gasoline to clean the UV lens.
8. Do not use unstable power supply or power supply that exceeds the voltage range of the handheld LiDAR device.
9. Do not turn on or turn off the camera frequently. Please wait for more than 60s at the interval of continuous power on or off, otherwise it will affect the life of the camera mechanism..
10. The handheld LiDAR device is kind of a precise equipment, please keep it stored in the shipping box during transportation process.

11. When the device is not in use for extended periods, it is recommended to perform regular maintenance on the battery to prevent damage caused by prolonged storage.

7 After Sales

7.1 Shipment

All equipment delivered by SHARE3DCAM shall be packed in accordance with the standard protective measures for packaging and transportation. Such packaging shall meet the requirements according to the specific properties of the equipment for long-distance transportation, moisture resistance, shock resistance, rust prevention, etc. to ensure that the equipment could be arrived safely at the place of delivery.

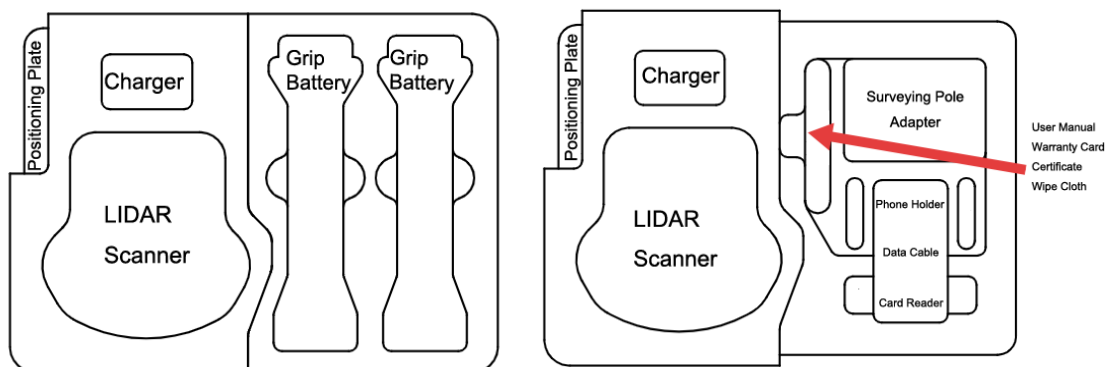

Shipping Box Content

The lining of the handheld LiDAR device shipping box adopts a two-layer design. The left side of the lining is fixed with the main unit and charger. The upper layer on the right side of the lining can hold two grip battery , and the lower layer can hold accessories such as mobile phone holder, card readers, data cables, surveying adapter, manual, etc. The shipping box is manufactured using industrial-grade box manufacturing techniques, with a folding snap-on lid and a convenient and durable handle design, providing high structural strength and durability. Keep the cover of the shipping box upward, and do not place it upside down. Avoid severe vibration and turbulence during transportation.

7.2 After-sales Service

- 1) Hardware warranty terms: 1 year warranty since delivery.

During the warranty period, Party B shall only undertake the delivery, maintenance and quality guarantee of Party A's goods within the territory of the People's Republic of China.

- 2) Warranty service: Regulations on after-sales service of

SHARE3DCAM

- 3) Party A: Buyer of Products Party B: SHARE3DCAM LIMITED

- 4) The after-sales service content shall refer to the after-sales service regulations of SHARE3DCAM.
- 5) During the warranty period, Party B will provide Party A with regular technical support free of charge, and bear the related costs of repair and replacement caused by product quality problems. Devices with below conditions will be out of warranty even if within warranty time: water damaged, for damage caused by non-quality problems, Party B will provide repairing service and charge to Party A. The warranty label shall not be opened, torn or destroyed privately, otherwise the warranty will be invalid.
- 6) If user have any questions, please contact SHARE3DCAM LIMITED
- 7) After-sales service and technical support tel: +86-755-23216686 (working days 9:00-18:00 Beijing time)

SHARE 3DCAM



Official Website



LinkedIn



YouTube



Facebook

If you have any questions about the product Please contact us via below email: technical.support@shareuavtec.com

SHARE3DCAM LIMITED

FCC Warning:

This equipment has been tested and found to comply with the limits for a Class B digital device, pursuant to part 15 of the FCC Rules. These limits are designed to provide reasonable protection against harmful interference in a residential installation. This equipment generates, uses and can radiate radio frequency energy and, if not installed and used in accordance with the instructions, may cause harmful interference to radio communications. However, there is no guarantee that interference will not occur in a particular installation. If this equipment does cause harmful interference to radio or television reception, which can be determined by turning the equipment off and on, the user is encouraged to try to correct the interference by one or more of the following measures:

- Reorient or relocate the receiving antenna.
- Increase the separation between the equipment and receiver.
- Connect the equipment into an outlet on a circuit different from that to which the receiver is connected.
- Consult the dealer or an experienced radio/TV technician for help.

Caution: Any changes or modifications to this device not explicitly approved by manufacturer could void your authority to operate this equipment.

This device complies with part 15 of the FCC Rules. Operation is subject to the following two conditions:

(1) This device may not cause harmful interference, and (2) this device must accept any interference received, including interference that may cause undesired operation.

This equipment complies with FCC radiation exposure limits set forth for an uncontrolled environment. This equipment should be installed and operated with minimum distance 20cm between the radiator and your body.