

TOWER®

over 100 YEARS of quality

T920002

Care & Use Instructions

PLEASE READ CAREFULLY



4 LITRE

ONE-TOUCH ULTIMA PRESSURE COOKER
STAINLESS STEEL

1. USER SAFETY INFORMATION

For your safety, please read and understand all the instructions before using your pressure cooker. Keep these instructions for your future reference.

1. The pressure cooker must be used by a responsible adult. Use and store it out of reach of children.
2. Do not leave the pressure cooker unattended while it's under pressure. You don't have to stand over it, but keep an eye on it.
3. Do not let children near the pressure cooker when in use. Close supervision is needed when the pressure cooker is used where there are children or pets around. Do not allow children to use the pressure cooker.
4. Do not place the pressure cooker in a heated oven.
5. Extreme caution must be used when moving the pressure cooker containing hot liquids or when it is at pressure. Do not touch hot surfaces. Use the handles or oven gloves when handling the pressure cooker.
6. Do not use the pressure cooker for a purpose other than its intended use. This pressure cooker is intended for domestic use only and is not designed for commercial use. The manufacturer accepts no liability if the appliance is used for commercial purposes or in a manner which does not comply with the instructions in this manual.
7. The pressure cooker heats and cooks food under pressure. Inappropriate use of the pressure cooker may result in a scalding injury. To avoid injury, ensure that the cooker is closed correctly and securely before applying heat. See details in the instructions.
8. When the food is at boiling temperature, and when the pressure is decreasing rapidly, steam and boiling liquid can escape from the pressure cooker. Take care of the ejected steam. Do not position the pressure cooker and the decompression window in close proximity to other people or yourself so as to prevent injury from escaping steam.
9. Never force open the pressure cooker until all the internal pressure has been completely and safely released. Strictly follow the instructions.
10. Never use your pressure cooker without adding a liquid that will give off steam when boiled i.e. water, wine, stock, beer, cider, etc, or letting it boil dry, as these will cause severe damage to the pressure cooker. Use at least 300ml (1/2pt) of liquid. This will give you up to 15 minutes cooking. When cooking for more than 15 minutes, increase the amount of water by 150ml (1/4pt) for each additional 15 minute period or part period.
11. Do not fill the cooker beyond 2/3 of its capacity. When cooking foodstuffs which expand during cooking, such as rice or dehydrated vegetables, do not fill the cooker to more than 1/3 or half of its capacity depending on the foodstuffs. See min and max fill guide in the instructions.
12. Use the appropriate heat source(s) according to the instructions for use. Only use the pressure cooker on a heat source with a stable position.

1. USER SAFETY INFORMATION

13. After cooking meat with a skin (e.g. ox tongue) which may swell under the effect of pressure, do not prick the skin while the skin is swollen, you may be scalded by escaping water/steam.
14. When cooking any doughy food, gently shake the pressure cooker before opening the lid to avoid food being ejected when you open it. Don't cook dumplings in the pressure cooker with the lid on. The dough will rise and may block the safety devices. Cook the food without dumplings for the recommended time, release the steam, remove the lid, then add the dumplings and cook them without the lid.
15. You may use boil-able plastic containers capable of withstanding 130°C (266°F) with the pressure cooker. Don't fit them with lids, they may blow off as the contents expand.
16. Tie down greaseproof or foil coverings or they may block the safety devices.
17. Before each use, check that the valves and sealing ring are not obstructed and in good condition. See the instructions for use.
18. Never use the pressure cooker in its pressurized mode for deep or shallow frying of food.
19. Do not tamper with any of the safety systems beyond the maintenance instructions specified in the instructions for use.
20. Only use authentic manufacturer's spare parts in accordance with the relevant model. In particular, use a body and a lid from the same manufacturer indicated as being compatible.
21. If the pressure cooker functions abnormally i.e. it has been dropped or show signs of damage, stop using it.
22. **KEEP THESE INSTRUCTIONS.**

CONTENTS

User safety Information	2-3
1. Specifications	5-6
1.1 Components, accessories and spare parts	5
1.2 Technical information	6
1.3 Suitable hob types for cooking	6
2. Using your pressure cooker – step by step guide	7-14
2.1 Benefits of using a pressure cooker	7
2.2 Before the first use	8
2.3 Filling your pressure cooker and steam cooking preparation	9-10
2.4 Selecting the cooking pressure	11
2.5 How to set the timer and change the battery	12
2.6 Starting to cook	12-13
2.7 At the end of cooking – steam release	14
2.8 Opening the pressure cooker	14
3. Basic rules of pressure cooking	15
4. Cleaning, maintenance and storage	15-17
5. Troubleshooting and disposal of the product	18-20
6. Cooking times and sample recipes	20-24
7. Warranty information	25
8. Your Receipt	26
9. Notes	27

1. SPECIFICATIONS

1.1 Components, accessories and spare parts

This box contains:

Pressure Cooker, 60-Minute Timer, 20cm Stainless Steel Steamer Basket, Steamer Wire Stand, Sealing Ring and Instruction Manual



Structure of your pressure cooker:

- | | |
|--------------------------------------------------|----------------------------------|
| 1. Pressure cooker lid | 7. Side handles |
| 2. 60 minute removable timer | 8. Food guard under the lid |
| 3. Twist lock/unlock handle | 9. Steamer basket |
| 4. Black pressure regulator & steam release pipe | 10. Steamer stand/trivet |
| 5. Decompression window | 11. Lid clamp |
| 6. Sealing ring/gasket | 12. Red pressure indicator valve |

Spare parts (not included, available to order via website/customer service should you require replacements)

Part No.	Description	Part No.	Description
TS1006	22cm sealing ring grey	TS3001	60mins digital timer
TS2012	Black pressure regulator	TS2014	Food guard
TS2013	Red pressure indicator valve		

1. SPECIFICATIONS

1.2 Technical Information

Model No:	T920002
Diameter:	22cm
Capacity:	4 Litre
1 Pressure Setting:	80kPa 11.6lb
Material:	Stainless steel 18/8 body and lid, encapsulated steel base for even heat distribution, phenolic handles
Featuring:	Unique twist lock/unlock lid handle Inner MIN and MAX markings 60-minute digital timer
Suitable Hob Types:	Ceramic / Electric / Gas / Halogen / Induction / Radiant / Sealed and solid plates
Factory Information:	Zhejiang Suntrue Cookware Co., Ltd.
Standard:	EN12778

1.3 Suitable hob types for cooking

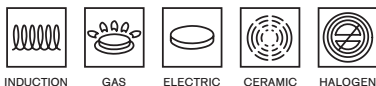

The Tower Pressure Cooker can be used on all types of hob, including gas and electric, with a power rating of less than 2KW.

When using an electric hob, ensure that the hob has a diameter as close as possible to that of the cooker. NEVER use a hob that is too large for the cooker base. Also ensure the pressure cooker is only used on a heat source with a stable position.

When using a gas hob, always ensure that the flames DO NOT encroach upon the sides of the cooker but remain beneath it. DO NOT place or attempt to heat the pressure cooker in a heated oven.

Always thoroughly clean and dry the base of the pressure cooker before placing on the hob.

When using your pressure cooker on ceramic style hobs such as halogen, lift and place your pressure cooker rather than dragging it across the hob surface, to minimise damage to both your hob and pressure cooker.

2. USING YOUR PRESSURE COOKER – STEP BY STEP GUIDE

Healthier and tastier food;
use less time and save energy

What foods?

A wide variety of meals, side dishes and deserts can be cooked using a pressure cooker.

- Beans, rice and pulses
- Joints of meat, poultry
- Pasta dishes
- Soups
- Steamed puddings
- Steamed vegetables
- Stews and casseroles
- And many more



2.1 Benefits of using a pressure cooker

Creates healthier and tastier foods; uses less time and save energy.

Healthier:

Retains more nutrients, vitamins and minerals. Vegetables retain their textures and flavour; meats stay tender, juicy and succulent.

Efficient:

Pressure cookers cook food up to 70% faster than conventional cooking techniques, saving you time and energy bills.

Versatile:

Less washing up is required as only one cooking pot is used and the pressure cooker lid eliminates splashes and boil overs.



2. USING YOUR PRESSURE COOKER – STEP BY STEP GUIDE

2.2 Before the first use

Before using your pressure cooker for the first time, it is recommended that all labels, packaging and accessories are removed. Retain the instruction manual. Pull the food guard off the tripod. Clean the pressure cooker following the cleaning instruction in this manual. Take care when cleaning around the tripod, the edges might be sharp.

To open the pressure cooker, use the twist lock/unlock handle, follow the arrows on the handle and turn the handle clockwise, a click sound indicates the lid is open. Lift the lid off of the cooker body.

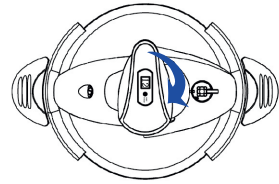

Before washing the pressure cooker, set the timer aside, do not let the timer come in contact with water, lift out the sealing ring from under the rim of the lid and take out the black pressure regulator. Wash all with a non-abrasive, mild detergent solution and rinse and dry thoroughly.

Ensure the sealing ring, food guard and the black pressure regulator are re-fitted correctly.

To remove any new product smell, fill the pressure cooker 2/3 full with water (add a tablespoon of fresh lemon juice or vinegar to the water to prevent discolouration after).

To close the lid, rest the lid on the cooker body, press it down slightly to make sure it's directly on top of the cooker body. Turn the lock/unlock handle anti-clockwise, a click sound indicates the two lid clamps are in place and the lid is closed correctly.

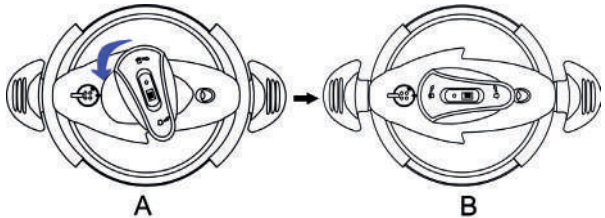

Align the small black dot of the black pressure regulator with the ● cooking position and heat for 15 minutes. Allow to cool (make sure the internal pressure has been completely released and the red indicator valve has dropped) and then empty the heated water. Rinse and dry. Your pressure cooker is now ready to use.

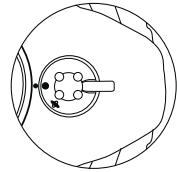

Safety checks before each use

- Lift the lid off the pressure cooker and keep the lid lock/unlock handle in the closed position. Take the black pressure regulator off the lid and carefully pull the food guard off the tripod. Hold it up to the light and make sure the black regulator, steam release pipe and the indicator valve are free of blockages.
- Turn the lid over, and check that the red pressure indicator valve moves freely.
- Remove the sealing ring, and gently stretch it all directions then replace it under the lid groove.
- Turn the lid the right way up and refit it on to the cooker body.

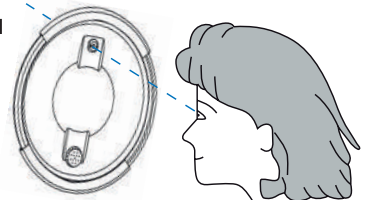

2. USING YOUR PRESSURE COOKER – STEP BY STEP GUIDE

2.3 Filling your pressure cooker and steam cooking preparation

Before filling your pressure cooker with your favourite ingredients, please read and follow the below minimum and maximum fill levels.



Minimum Fill Level

Liquid	Cooking Time
300ml or 1/2 pint	For the first 15 minutes of cooking
150ml or 1/4 pint	For each additional 15 minutes or part of 15 minutes

Note: Please ensure the above is strictly followed to avoid the risk of boiling dry.

Maximum Fill Level

Fill Level	Types Of Foods
Do not exceed 2/3 of the volume	Solid meat and vegetables which do not expand or foam when cooked.
Do not exceed 1/2 of the volume	Dried vegetables, soup, stews, etc, which need room for the food to expand without blocking the steam pipe.
Do not exceed 1/3 of the volume	Rice, cereal, pearl barley, oatmeal or other cereals, pulses which expands quite a lot when cooked, will need extra room.
Do not cook these foods in the pressure cooker.	Foods such as macaroni, noodles and spaghetti etc, that produce large amount of foam during cooking are not suitable for pressure cooking, as they may block the steam pipe. We do not recommend these to be cooked using a pressure cooker.
	Food with skins - Always pierce the skins before cooking.

Note: The above is only a general guide. Please check your recipes for any exceptions to these rules.

Steam cooking

The steam basket should be placed on top of the steamer stand in the pressure cooker to allow the steam to circulate freely in and around the food. At least 750ml or 1 and ¼ pint of water should be used for steam cooking. The water level must not exceed the level of the steamer stand otherwise the food will be immersed in the water instead of cooking in steam.

Some heatproof containers may be used in the pressure cooker i.e. metal, enamel, glass, earthenware or boil-able plastic. Do not use any containers that are cracked. Containers should easily fit into the cooker and must not come to within 2.5cm (1") of the top of the cooker body. Caution: Always use oven gloves when handling any hot containers.

Pre-steaming

Some recipes, such as Christmas pudding, require pre-steaming before being brought to cooking temperature. Pre-steaming can be carried out in a closed pressure cooker, over a medium heat with the pressure regulator left off.

Make sure there is enough water in the pressure cooker to cover the pre-steaming and the normal cooking time. Once steaming begins, the heat should be turned down as low as possible in order to reduce the amount of steam that escapes and the amount of water that is consumed. Once pre-steaming is complete, check that there is still sufficient water remaining to complete the cooking stage. If in doubt, remove the lid and check the water level before moving from pre-steaming to pressure cooking. The lid should be locked into position, the pressure regulator fitted and the heat turned up to bring the pressure cooker up to cooking pressure.



2. USING YOUR PRESSURE COOKER – STEP BY STEP GUIDE

2.4 Selecting the cooking pressure

This pressure cooker has one black pressure regulator with one cooking pressure 80kpa/11.6lb. Ensure the small black dot on the regulator is directing at the cooking or steam release position.

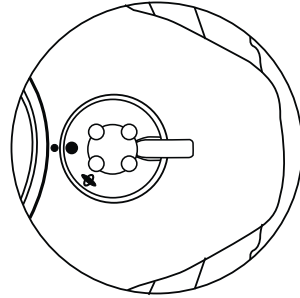

Icon	Feature
●	Cooking position
☰	Steam release position

Steam release:

At the end of cooking, if your recipe requires quick release of the pressure, lift the regulator up slightly and gently move over to the steam release position. Please handle with care as the hot steam will be released quickly.

Caution:

When moving the regulator from the cooking position to the steam release position, do not completely pull the regulator out and reposition it as it will cause scalding injury due to the internal pressure is at its highest level and the hot steam/liquid will be ejected from the steam release pipe.

If liquid starts ejecting from the steam release pipe while releasing the steam, the food may not be suitable for quick release. Turn the regulator back to the cooking position and let the pressure cooker cool naturally.



2. USING YOUR PRESSURE COOKER – STEP BY STEP GUIDE

2.5 How to set the timer

The timer can be removed from the lock/unlock handle and replaced after. To set the timer, press the blue button on the timer. The number '00' will be displayed. Then press the button the required number of times – i.e. if you need 10 minutes, press the button 10 times.

The digital clock will then start counting down and, when it reaches "00" the alarm will sound. To stop the alarm, press the blue button. After a few seconds, the numbers will disappear.

If you wish to stop the time counting down, press and hold down the blue button for a few seconds; the numbers "00" will be displayed and then the screen will go clear.

Changing the battery in the timer: If the battery needs changing, use a 1Op coin to open the cap of the timer located at the bottom of the timer. Remove the old battery by using a non-metal stick to shake it out. Carefully insert the new battery (This pressure cooker is supplied with 2 spare type AG13 batteries.) and ensure the side with battery model number on is facing outwards. Replace the lid and use the coin to tighten the battery into position. Press the blue button on the timer to check if it is now working. You should see the number "00". Insert the timer into the slot of the lock/unlock handle.

2.6 Start to cook

Turn the hob to the highest setting in order to get the pressure cooker to the required cooking pressure as quickly as possible. When using a gas hob, ensure the flame is under the pressure cooker and does not encroach upon the sides.

Note: Some steam will escape from the red pressure indicator valve after the pressure cooker has been heating. This is normal and will cease once the red pressure indicator valve has risen. It's now not possible to open the lid until the pressure has been safely released at the end of cooking.

The time for the pressure cooker to reach the required cooking pressure varies depending on the amount of food being cooked and the temperature of the food when the cooking commences.

Once the required cooking pressure has been reached:

- a. The red pressure indicating valve will rise.
- b. Excess steam will escape intermittently from the pressure regulator, emitting a hissing sound as it does so.



2. USING YOUR PRESSURE COOKER – STEP BY STEP GUIDE

At this point the heat should be turned down to the lowest possible level and you can start timing the cooking process.

If the heat is too high, there will be a constant loud hissing sound. If the heat is too low, there is little or no noise. You may need to adjust the heat level during cooking to maintain constant pressure. If the pressure indicator drops down during cooking, increase the heat slightly and extend the cooking time.

Cooking time:

The cooking time begins directly as the heat is turned down, once the red pressure indicator valve rises and the pressure cooker begins to hiss to release excess steam. Once the cooking time has finished, the hob should be turned off and the pressure cooker allowed to cool.



Caution:

- a. Do not leave the pressure cooker unattended during cooking.
- b. Do not touch the metal surfaces of the pressure cooker during cooking as they will be very hot. Always use oven gloves and hold the pressure cooker by both handles, keeping the pressure cooker level.
- c. Keep the pressure cooker away from children and pets.
- d. Never remove the pressure regulator until all the pressure has been released.

2. USING YOUR PRESSURE COOKER – STEP BY STEP GUIDE

2.7 At the end of cooking – Steam release

When the cooking time indicated in the recipe has finished, turn off the heat and release the steam either quickly or slowly as indicated in the recipe or according to the type of food cooked.

Quickly: For stews, vegetables and fish dishes.

Turn the pressure regulator to the steam release position. Take great care as hot steam is released through the regulator. Make sure there is nothing in the way of where the steam will travel to.

Slowly: For recipes containing rice or pasta, egg custards, puddings, dried vegetables, pulses and stocks. This is the natural cooling, preferred method.

Using oven gloves and gripping the handles, carefully move the pressure cooker on to a level, heat-resistant surface and leave it to stand until the pressure has reduced and the red pressure indicator valve has lowered. This process normally takes about 15 minutes (depending on the amount of food being cooked, it may vary slightly) to cool at room temperature.

Before opening the pressure cooker lid:

- a. Wait until the steam inside the cooker has completely released;
- b. The red pressure indicator valve has dropped down;
- c. The pressure regulator has been removed to safely open the lid.

Caution: The pressure cooker will require a gentle shake to disperse any air bubbles or residual pressure prior to opening the lid after cooking certain foods, such as rice or soup. Always wait for the pressure to completely reduce before shaking.

2.8 Opening the pressure cooker

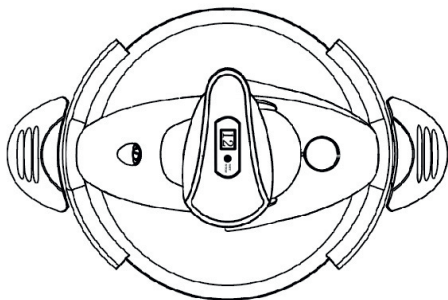

To open the pressure cooker, use the twist lock/unlock handle, follow the arrows on the handle and turn the handle clockwise, a click sound indicates the lid is open. Hold the side handle with one hand and lift the lid off with another.

Note: Remove food from the pressure cooker as soon as possible after cooking.

Do not leave food in the cooker for a long period of time as this may discolour the interior.

3. BASIC RULES OF PRESSURE COOKING

Strictly follow the minimum and maximum fill levels in this manual. Check in recipes for any exceptions to this rule such as Christmas puddings, pulses and steamed puddings, as extra liquid is required.

Always use a liquid that will give off steam when boiled i.e. water, wine, stock, beer, cider, etc. All pressure cooking requires liquid. Never just use oil or melted fat only.

Pressure cooking times vary accordingly to the thickness and size of the food and not the weight. For example, half a kilo of potatoes cut into quarters takes 7 minutes to cook. Half a kilo of potatoes cut in half takes 10 minutes.

Never cook dumplings with the lid securely closed as they could rise and block the safety devices. Cook the stew and at the end of the cooking time, release the steam and add the dumplings to the pressure cooker. Cook gently for about 10-15 minutes without the lid on.

Cooking containers and coverings must be able to withstand temperatures of 130°C (266°F). Do not use plastic lids as they prevent steam from being in contact with the mixture. Coverings on containers i.e. foil, must be securely tied otherwise they could block the safety devices.

The cooker body can be used without the lid for pre-frying foods i.e. to brown and seal meat. Always remove the cooker from the heat source and allow to cool slightly before adding the liquid, otherwise the liquid could evaporate off and leave insufficient for pressure cooking.

When pressure cooking times are short, such as for vegetables and fruit, accurate timing is essential to avoid overcooking.

If adapting a conventional recipe for pressure cooking, a general guide is to calculate one-third of the conventional cooking time. For example, if the usual cooking time is one and a half hours, the pressure cooking time is half an hour.

Calculate the amount of liquid required according to the pressure cooking time and type of food. This model of pressure cooker operates at 80kPa. The cooking times in pressure cooker recipe books suggesting using higher pressure may require less cooking time than these models. These recipes can be adjusted for use in your pressure cooker by increasing the cooking time and altering the quantity of liquid used accordingly.

4. CLEANING, MAINTENANCE AND STORAGE

Cleaning your pressure cooker

After every use, the pressure cooker should be carefully cleaned and thoroughly dried before putting away. The pressure cooker is not suitable for storing food when not in use. Salted and acidic food will mark the interior.

Only the cooker body is dishwasher safe. Do not put any other parts of the pressure cooker in a dishwasher. We recommend this pressure cooker to be hand washed by using a mild detergent and warm water. Dry immediately and thoroughly.

To avoid damaging the surface of the pressure cooker, do not use implements or cleaning materials made from metals, hard materials or abrasives.

To remove stubborn food residuals on the inner walls of the pressure cooker, use a suitable cleaning solution mixed with warm water and leave to soak until softened and ready to be cleaned.

Do not leave the exterior of the pressure cooker to soak in water as this will damage the exterior finish.

4. CLEANING, MAINTENANCE AND STORAGE

To clean the lid, remove and wash the sealing ring and regulator. Rinse the lid under running warm water. Do not immerse the lid in water. Check all the safety devices are clean and dry.

Make sure the steam release pipe is clear. If it's blocked, turn the lid upside down and use a 2mm diameter needle or skewer to clear the blockage and rinse under a tap.

If the inside of the pressure cooker body becomes discoloured due to hard or chalky water, or cooking ingredients i.e. salt and oil, any white spots or discolouration on the inner walls and base of the pressure cooker can be removed by wiping with fresh lemon juice, then rinse and dry immediately and thoroughly.

To prevent discolouration, add a tablespoon of lemon juice or vinegar to the water when steaming foods i.e. Christmas pudding, steamed puddings and vegetables.

Maintenance

After each use, check whether the following parts need maintenance. Do not attempt to dismantle any other parts of the pressure cooker other than those mentioned. Available replacements parts are listed in the product specification section.

The body and lid

Check before each use if the body and the lid are in good condition. If they show any signs of fatigue or damages, stop using the pressure cooker.

Occasionally, use a suitable stainless steel polish and soft cloth to maintain the original shine of the exterior. Do not immerse the lid in water. Rinse the lid under running warm water.

The sealing ring

We recommend that the sealing ring be replaced every one or two years, depending upon the amount of use.

Do not use substitute sealing ring otherwise your guarantee will be invalidated. You can order your replacement sealing ring for this model from the Tower website or by calling our customer helpline.

Wash the sealing ring after each use in warm water and detergent to remove any debris from both the seal and the groove in which it sits. The sealing ring lifts out and is put back by easing in place under the rim of the lid.

Note: If the pressure cooker is not used for a long period of time, the sealing ring may need replacing as it can harden and then will not form an air-tight seal. Replace the seal immediately if it is damaged or has changed shape.

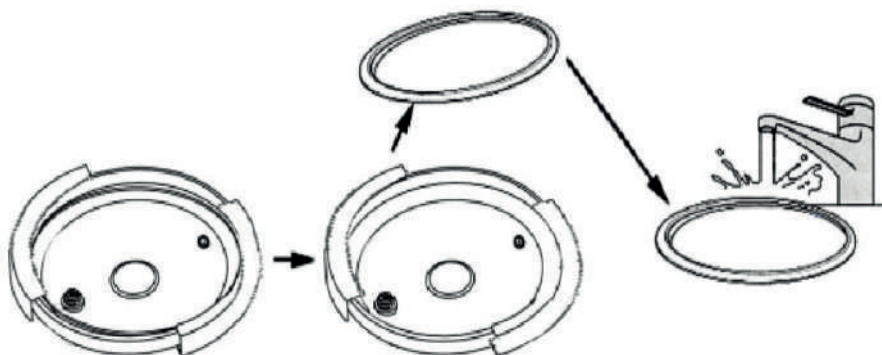

4. CLEANING, MAINTENANCE AND STORAGE

The pressure regulator

The pressure regulator must be cleaned after each use. After lifting the pressure regulator off the lid, clean and rinse the pressure regulator under running water.

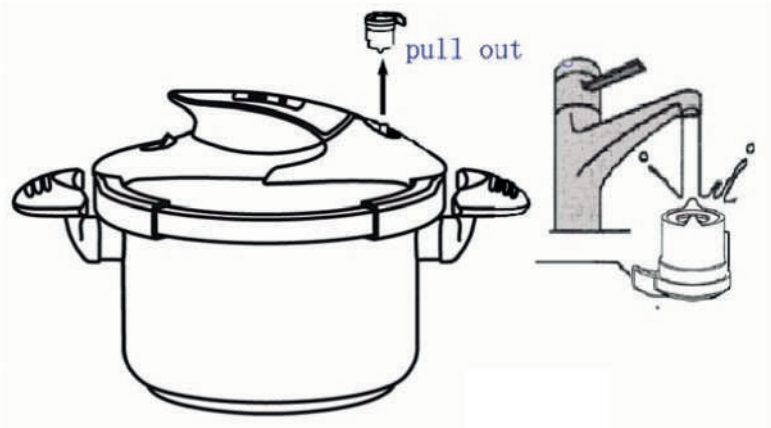

The steam release pipe

The pipe is under the pressure regulator. Remove the pressure regulator by lifting upwards. Check before each use that the pipe is not blocked. Hold it up to the light and make sure that the pipe is clean and free of food debris.

Clean with a needle or skewer, especially after cooking foods which produce scum (puddings, rice, lentils, etc). Check that the hole at the base of the pipe is clean.

Red pressure indicator valve

Keep the lid lock/unlock handle in the closed position. Turn the lid over, and check that the red pressure indicator valve moves freely.

Food guard

Pull the food guard off the tripod for cleaning. Use soft dish cloth to clean the areas around the tripod. Take care when cleaning the tripod, the edges of the tripod may be sharp. Thoroughly dry or air dry the food guard and tripod area before refitting. When refitting the food guard, it may require you push the food guard down the tripod quite hard to ensure it's fitted in place. If it's fitted correctly, the edge of food guard should flush with the lid to prevent debris from getting into the steam pipe.

Storage



Please make sure all parts are thoroughly dried before storage. To avoid damage to the sealing ring, do not store your pressure cooker with the cover fitted in place; instead, place the cover upside down, with the seal uppermost and store the pressure cooker in a cool, dry place away from direct sunlight.

5. TROUBLESHOOTING

If your pressure cooker is not performing as it should, turn off the heat source immediately, taking special care to protect your hands and yourself.

Do not move the pressure cooker. Leave it to cool naturally and wait until all the pressure has been released completely, then open the lid safely and examine and take appropriate actions.

The table below details some common problems and how to solve them.

Problem	Cause	Solution
The pressure cooker does not come to pressure. The red pressure indicator valve is not rising.	The heat is too low.	Increase the heat.
	No liquid.	Add liquid.
	The pressure regulator is incorrectly positioned.	Reposition the regulator and close it correctly.
	The pressure cooker lid is closed incorrectly.	Check the lid and close it correctly.
	The steam release pipe is blocked.	Check and clean the steam pipe.
	The sealing ring needs changing.	Replace the sealing ring.
Steam escapes from under the cover. 	The lid is closed incorrectly.	Check if the lid is fitted correctly in place.
	The sealing ring is not fitted correctly.	Clean the sealing ring and refit.
	The sealing ring is dirty.	Clean the sealing ring, the rim of the cooker body and the rim of the cover.
	The sealing ring is old or damaged.	Replace the sealing ring.
	The lid is damaged or dented or faulty.	Dispose the product if it has reached its end of life or refer to the warranty.
Steam and liquid suddenly escape from the pressure regulator or from under the lid.	The pressure cooker safety devices have operated or the pressure regulator is blocked.	Turn off the heat and allow the pressure cooker to cool and the pressure to reduce. Open the lid and clean the pressure regulator.
	The pressure cooker safety devices have operated.	The sealing ring has been activated and has started decompressing the excess pressure. Check if the steam pipe is blocked.
Steam and liquid leaks from the red pressure indicator valve. 	Steam release pipe may be blocked.	Turn off the heat and allow the pressure cooker to cool and pressure to reduce. Open the lid and clean the steam release pipe.
	Red pressure indicator valve has become faulty.	Replace the red pressure indicator valve.

5. TROUBLESHOOTING CONT.

Problem	Cause	Solution
<p>The sealing ring/gasket is suddenly forced out from the decompression window and steam starts emitting from the cooker.</p> 	<p>The safety function of the sealing ring/gasket is working and other parts of the pressure cookers may need to be checked.</p>	<p>Wait till the pressure cooker cools down. Check and clean any other parts of the pressure cooker free from blockage or check if any parts need replacing.</p>
	<p>Sealing ring/gasket may be old or damaged.</p>	<p>Replace the sealing ring.</p>
<p>The lid can not be opened.</p>	<p>There is still pressure inside the pressure cooker.</p>	<p>Release the pressure correctly and completely. Do not force open the lid.</p>
	<p>Due to high temperature, the sealing ring might have melted.</p>	<p>The lid can then only be removed by a qualified technician (This is not covered by the warranty).</p>
<p>The pressure cooker was heated without any liquid by error.</p>	<p>Misuse of the product.</p>	<p>Have the product checked over by a qualified technician to determine if it's safe to continue using the product as it may be damaged. This is not covered by the warranty. Otherwise dispose of the product as it has reached its end of life.</p>
<p>The lid will not lock to the cooker body.</p>	<p>The lid and the body are not aligned correctly.</p>	<p>Check that the lid is sitting directly above the cooker body, press the lid down slight, then twist the lock/unlock handle to lock the lid in position.</p>
<p>The food is not cooked.</p>	<p>Heat was too low causing loss of pressure.</p>	<p>Adjust the heat to maintain a constant pressure and extend the cooking time.</p>
	<p>Loss of pressure.</p>	<p>The sealing ring needs refitting, cleaning or changing.</p>
	<p>Required cooking time was not achieved.</p>	<p>Check your recipes for the correct cooking time.</p>
<p>The food is burnt.</p>	<p>Incorrect cooking time.</p>	<p>Clean the burnt food and check the pressure cooker for any signs of damage. Check and follow the correct cooking time.</p>
	<p>Heat was too high.</p>	<p>Liquid has been evaporated too fast and the food was left with insufficient liquid. Higher heat doesn't mean the food will be cooked faster, it only wastes energy. Reduce the heat to maintain constant pressure.</p>
	<p>Not enough liquid.</p>	<p>Check the instructions for guidance.</p>

Note: If you continue having issues with your pressure cooker or would like some advice of how to use the product, please contact a member of our customer service team. They would be happy to help you. The details of the customer service team can be found at the back of this manual.

Disposal of the product

Please visit www.recycle-more.co.uk or www.recyclenow.co.uk for access to information about the recycling of non-electrical items.

Please arrange to take this appliance to your local Civic Amenity site for recycling, once it has reached the end of its life.

6. COOKING TIMES AND SAMPLE RECIPES

The cooking time begins directly as the heat is turned down, once the red pressure indicator valve rises and the pressure cooker begins to hiss to release excess steam. Once the cooking time has finished, the hob should be turned off and the pressure cooker allowed to cool. Cooking times are determined by the size of the pieces of food. It's best to cut different foods to a uniform size if they are going to be cooked together. If necessary, cooking may be interrupted, pressure released, and foods with shorter cooking times added later.

Use these cooking times purely as a guide. Check food is cooked through before serving. If in doubt, increase the cooking time.

Cook meat, poultry, and any derivatives (mince, burgers, etc.) until the juices run clear.

Cook fish until the flesh is opaque throughout.

When cooking pre-packed foods, follow any guidelines on the package or label.

Soup – 4 to 6 minutes



Rice – 6 to 15 minutes



Fish – 3 to 8 minutes



Beef – 12 to 15 minutes (per 450g/lb)



Fruit – 2 to 5 minutes



Poultry – 5 to 8 minutes (per 450g/lb)



6. COOKING TIMES AND SAMPLE RECIPES

Food	Cooking Times (Minutes)
------	-------------------------

Soup

Chicken	6
Fish	5
Leek and potato	5
Onion	4
Vegetable	5

Vegetables

Carrots	6
Leeks	4
Potatoes	6
Runner beans	6

Fish & Shellfish

Lobster	8
Crab	5-8
Steaks and fillets	3-4
Whole fish	4 min per 450g/lb
Skate wings	4

Fruit

Apple slices	4
Blackcurrants	2-5
Damsons	4
Gooseberries	4
Peaches/pears	3-4
Raspberries	2-5
Rhubarb	4

Dried Fruit

Apricots / Peaches	3-4
Apples / Figs	4-5
Pears / Prunes	4-5

Food	Cooking Times (Minutes)
------	-------------------------

Rice

Long grain	6
Brown, long grain	12-15

Veal

Breast	12 min per 450g/lb
Knuckle	12 min per 450g/lb
Loin	10 min per 450g/lb
Shoulder	12 min per 450g/lb

Beef

Topside	12-15 min per 450g/lb
Brisket	15 min per 450g/lb
Silverside	12 min per 450g/lb

Pork

Shoulder	12 min per 450g/lb
Loin	12 min per 450g/lb

Lamb

Breast	12 min per 450g/lb
Shoulder	13 min per 450g/lb
Best end	10 min per 450g/lb

Poultry

Poussin (whole)	5-7
Chicken (whole)	5mins per 450g/lb
Partridge (whole)	8
Pheasant (whole)	8

Note: Please make sure any frozen food is completely defrosted before the cooking commences.

6. COOKING TIMES AND SAMPLE RECIPES

Beef Stew

Cooking Instructions

1. Heat the oil in the bottom of the pressure cooker over medium high heat. Add the onion and beef, and cook until browned on the outside.
2. Stir in the stock, water, carrots and salt, close the lid, and secure the pressure regulator. Heat until you start to hear sizzling, then reduce the heat to medium, and set your timer for 20 minutes.
3. Meanwhile, place the potatoes in a saucepan with enough water to cover. Bring to the boil, and cook until tender, about 10 minutes. Drain. This whole process should take about the same amount of time as the rest of the stew.
4. When the 20 minutes are up, release the pressure from the cooker according to the manufacturer's instructions.
5. Remove the lid, and place the pot over medium heat. Bring to the boil. Stir the cornflour into a small amount of cold water until dissolved. Stir this into the stew, and cook for a few minutes. Add the potatoes to the stew, or place them in serving dishes, and ladle the stew over them.

Ingredients

1 tablespoon olive oil
1 small onion, diced
1 kg beef stewing meat, cubed
225ml beef stock
225ml water
5 carrots, peeled and diced
1 dessert-spoon salt, or to taste
8 medium baking potatoes, peeled and diced
1 dessert-spoon cornflour

Prep time

15 MINUTES

Serves

8

Ready in

35 MINUTES

Cooking time

10 MINUTES

Food Allergies

Important Note: Some of these recipes may contain nuts and/or other allergens. Please be careful when making any of our sample recipes that you are NOT allergic to any of the ingredients. For more information on allergies, please visit the Food Standards Agency's website at: www.food.gov.uk

More pressure cooker recipes and recipe books can be found online and in local book stores and retailers.

6. COOKING TIMES AND SAMPLE RECIPES

Leek and Hazelnut Risotto

Cooking Instructions

1. In a medium sized pot, bring the stock to the boil. Peel the carrots and cut them into little cubes. Cut the leeks in half lengthways, wash them under running water, get rid of the dark green part and then cut them into little (2mm) pieces.
2. Put the pressure cooker on medium heat and melt 1 knob of butter. Brown the leeks, carrots and the rosemary sprig. Pour half of the white wine and let it simmer. (Keep the other half for later to pour over the rice.)
3. When the wine has evaporated, add the rice, mixing it so that the butter is absorbed, and then pour the rest of the wine over the rice. Let the wine evaporate again. Add the salt and the boiling stock to the rice, stir and close the pressure cooker straight away.
4. Put the pressure cooker to the highest heat level and bring it to pressure. Depending on the model, you can turn off the cooker when it gets to pressure or lower the heat. Calculate about 4 minutes from when the pressure cooker comes to pressure.
5. While the rice is cooking, toast the hazelnuts in a dry frying pan on medium heat for a few minutes until they are golden, stirring constantly.
6. After 4 minutes in the pressure cooker, remove it from the heat, relieve the pressure by letting the steam escape. Pay attention while doing this because some liquid can come out of the valve.
7. Open the pressure cooker, stir the risotto and check to see if it needs more salt. Add the other knob of butter and stir, letting it cream the risotto before serving. Serve the risotto with a generous sprinkling of Parmesan cheese and the toasted nuts.

Ingredients

850ml hot meat or vegetable stock
 2 baby carrots
 2 to 3 small leeks
 1 knob of butter
 1 rosemary sprig
 225ml dry white wine
 400g Carnaroli, Arborio or Vialone Nano rice
 1 teaspoon salt (or less if the stock is already salty)
 1 handful of hazelnuts, roughly chopped with a grinder
 1 knob of butter
 Grated Parmesan cheese, to serve

Prep time

10 MINUTES

Serves

4

Ready in

25 MINUTES

Cooking time

15 MINUTES

6. COOKING TIMES AND SAMPLE RECIPES

Chocolate Pudding

Cooking Instructions

1. Butter a 1.2 litre pudding basin. Cream the butter with the sugar until light and fluffy. Beat the eggs in a separate bowl and add gradually. Add the vanilla extract and mix in.
2. Meanwhile, heat at least 5cm water in your pressure cooker with a steamer insert or an improvised steamer rack in place.
3. Sift the flour and cocoa into the mixture. Gently fold, adding the chocolate. Add a tablespoon of water until the mixture is soft enough to drop from the spoon.
4. Pour the mixture into your prepared basin, filling only three-quarters to allow room to rise.
5. Take a double square of greaseproof paper, large enough to hang over the rim of the basin by a few centimetres, and fold a pleat into it. Butter the underside and secure the paper with a long piece of string under the rim. Loop the string over the basin and tie on the opposite side to make a handle.
6. Put the basin into the steamer, cover the pressure cooker without clamping the cover closed and steam for 15 minutes. This is essential to allow the sponge to rise.
7. Now clamp on the cover. Bring up to full pressure, turn the heat down to medium and cook for 25 minutes.
8. Turn off the heat and release the pressure immediately. Remove the basin using the handle. Run a knife around the inside of the basin and turn out on to a plate. Serve with double cream or crème fraîche.

Ingredients

Butter 100g, plus a little extra
Golden caster sugar 100g
Eggs 2
Vanilla extract 1 tsp
Self-raising flour 100g
Cocoa powder 1 tbsp
Grated dark chocolate 2 tbsps

Prep time

15 MINUTES

Serves

4-6

Ready in

35 MINUTES

Cooking time

20 MINUTES

7. WARRANTY



We hope that you will enjoy your Tower pressure cooker for many years.

As a thank you for purchasing one of our fantastic products, we are offering you 10 years peace of mind.

To receive your 10 year guarantee, simply register your product online by visiting www.towerhousewares.co.uk



This product is guaranteed for 12 months from the date of original purchase.

The main body and lid are guaranteed for the extended free warranty subject to registration. The spares and accessories are guaranteed for 1 year with proof of purchase.

If any defect arises due to faulty materials of workmanship, the faulty products must be returned to the place of purchase.

Refund or replacement is at the discretion of the retailer.

Extended warranty only valid with proof of purchase. Proof of purchase and the registration certificate must be kept for the entirety of the guarantee.

The Following Conditions Apply:

- The product must be returned to the retailer with proof of purchase.
- The product must be installed and used in accordance with the instructions contained in this instruction guide.
- It must be used only for domestic purposes.
- It does not cover wear and tear, damage, misuse or consumable parts.
- Tower has limited liability for incidental or consequential loss or damage.

This guarantee is valid in the UK and Eire Only.

The standard one year guarantee is only extended to the maximum available for each particular product upon registration of the product within 28 days of purchase. If you do not register the product with us within the 28 day period, your product is guaranteed for 1 year only.

To validate your extended warranty, please visit www.towerhousewares.co.uk and register with us online. Alternatively, call our customer registration line on +44 (0)333 220 6066.

Please note that length of extended warranty offered is dependent on product type and that each qualifying product needs to be registered individually in order to extend its warranty past the standard 1 year.

8. YOUR RECEIPT

Affix your store receipt to this page for safe keeping.

Should you have a problem with your product, or need any help, please contact our Service Department on **+44 (0) 333 220 6066**

AFFIX
RECEIPT
HERE

9. NOTES



TOWER®

over 100 YEARS of quality

THANK YOU

We hope you enjoy your product for many years. As a thank you for purchasing one of our fantastic products, we are offering you an extra 9 years peace of mind.

To receive your extra 9 years guarantee, register your product online by visiting:

www.towerhousewares.co.uk

Should you have a problem with your product, or need any spare parts, please contact our Service Department on:

+44 (0)333 220 6066

Your warranty becomes void should you decide to use non Tower spare parts. Spare parts can also be purchased from www.towerhousewares.co.uk
