



# COMMERCIAL FREEZER/REFRIGERATOR GLASS DOOR REFRIGERATOR

## TABLE OF CONTENTS

- Product Registration..... 2
- Important Safety Instructions..... 2
- Electrical Information..... 3
- Installation and Setup..... 3-4
- Appliance Start-up..... 5
- Features..... 5
- Routine Maintenance..... 6
- Energy Conservation Measures..... 7
- Troubleshooting Guide..... 8-9
- Wiring Diagram..... 10
- Warranty..... 11



# Product Registration

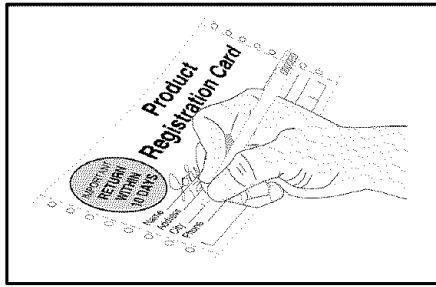

These instructions include information which is intended to assure the operator of correct installation, operation and service. Before attempting installation, adjustment or maintenance, be certain of the following:

- That you have read and fully understand the instructions.
- That you have all the tools required and are trained to use them.
- That you have met all installation and usage restrictions and are familiar with the functions and operations of the unit.
- That you follow all instructions exactly as given.

All the fittings, measurements, recommendations and procedures are significant. Substitutions and approximations must be avoided. Improper handling, maintenance, installation and adjustment, or service attempted by anyone other than a qualified technician, may void the future warranty claims and cause damage to the unit and/or result in injury to the operator and/or bystanders.

## Record your Model and Serial Numbers

Record the model number and serial number of this appliance in the space provided below (the serial plate is located inside the cabinet compartment).

Model No. \_\_\_\_\_  
Serial No. \_\_\_\_\_  
Installation Date \_\_\_\_\_  
Invoice Date \_\_\_\_\_  
Start-up Date \_\_\_\_\_  
Telephone for Service \_\_\_\_\_

## Register Your Product

The self-addressed **PRODUCT REGISTRATION CARD** (shown above) should be filled in completely, signed and returned to the address provided.

# Important Safety Instructions

Read all instructions before using this appliance

## **WARNING** For Your Safety

Do not store or use gasoline or other flammable vapors and liquids in the vicinity of this unit or any other appliance. Read product labels for flammability and other warnings.

## **WARNING** Child Safety

- Destroy carton, plastic bags, and any exterior wrapping material immediately after the appliance is unpacked. Children should never use these items for play. Cartons covered with rugs, bedspreads, plastic sheets or stretch wrap may become airtight chambers and can quickly cause suffocation.
- A child might suffocate if he crawls into the appliance to hide or play. Remove the door/lid of the appliance when not in use, even if you plan to discard the appliance. Many communities have laws requiring you to take this safety precaution.

## Proper Disposal of Appliance

### **WARNING** Risk of Child Entrapment

Child entrapment and suffocation are not problems of the past. Junked or abandoned refrigerators or freezers are still dangerous – even if they will sit for “just a few days”. If you are getting rid of your old refrigerator or freezer, please follow the instructions below to help prevent accidents:

- Remove the door.
- Leave shelves in place so children may not easily climb inside.
- Have the refrigerant removed by a qualified technician.

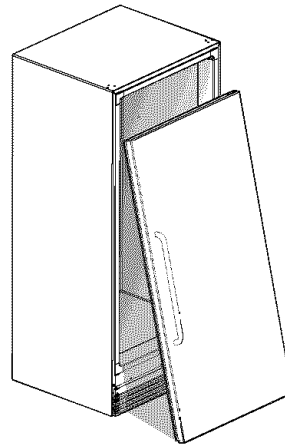

## **⚠ WARNING** Electrical Information

These guidelines must be followed to ensure that safety mechanisms in the design of this appliance will operate properly.

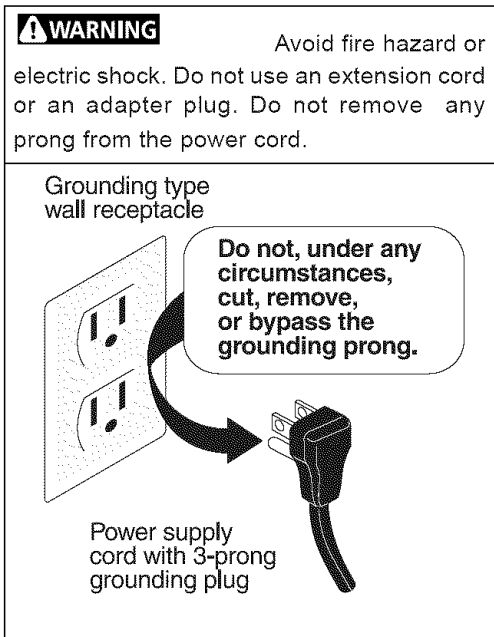

- Refer to the serial plate for correct electrical rating. The power cord of the appliance is equipped with a three-prong grounding plug for protection against shock hazards. It must be plugged directly into its own properly grounded three-prong receptacle, protected with a 15 amp time delay fuse or circuit breaker. The receptacle must be installed in accordance with the local codes and ordinances. Consult a qualified electrician. Receptacles with Ground Fault Circuit Interrupters (GFCI) are **NOT RECOMMENDED**. **DO NOT USE AN EXTENSION CORD OR AN ADAPTER PLUG.**
- If the voltage varies by 10 percent or more, appliance performance may be affected. Operating the appliance with insufficient power can damage the motor. Such damage is not covered under the warranty. If you suspect your voltage is high or low, consult your power company for testing.
- To prevent the appliance from being turned off accidentally, do not plug the unit into an outlet controlled by a wall switch or pull cord.
- **DO NOT** pinch, knot, or bend the power cord in any manner.

## **⚠ WARNING** Other Precautions

- **NEVER** unplug the appliance by pulling on the power cord. Always grip the plug firmly and pull straight out from the receptacle.
- To avoid electrical shock, unplug the appliance before cleaning.

**NOTE:** Turning the control to "OFF" turns off the compressor but does not disconnect power to other electrical components.

## Installation and Setup

### Inspection for Damage

Inspect the underside of the cabinet and packaging for damage such as a fork truck can cause. If hidden damage is found after uncrating, immediately call the delivery carrier and request an inspection. Retain all packaging and crating materials until the inspection is complete.

### Uncrating and Set-up

- Remove carton and all loose parts from inside of the unit.
- Tip the unit onto its back with the help of one assistant. Lay the unit gently to rest on blocks to avoid damaging the condensate drain hose, and the plastic raceway that covers the evaporator tubing on the back of the cabinet.
- Remove and discard the two (2) wood skids from the bottom and the four (4) screws (see the Fig. 1).
- Remove the bottom door hinge and screw on the lower left hand side of the cabinet used to support the glass door during shipping using a 3/8 socket wrench (see Fig. 2).
- Remove the package containing the casters from the unit. This package will contain the following items:
  - Two (2) caster rail supports (A)
  - Two (2) spacer plates (B)
  - Eight (8) carriage bolts (C)
  - Four (4) bolts (D)
  - Four (4) washers (E)
  - Eight (8) locking nuts (F)
  - Two (2) swivel casters (G)
  - Two (2) fixed casters with brakes (H)

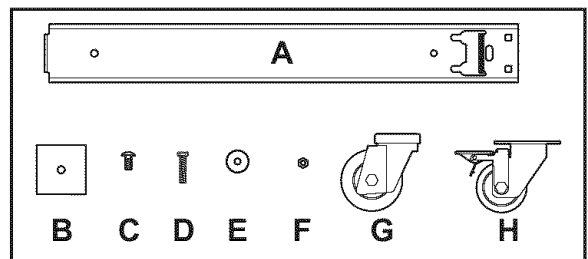

Figure 1

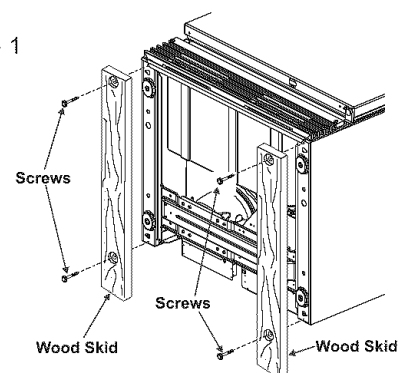
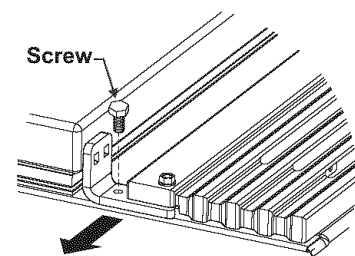

Figure 2



## Front Fixed Caster Installation

- Put two (2) carriage bolts through the rear (non-brake) side of the fixed caster and hold the carriage bolts loosely in place by threading several turns each on the locking nuts. Do not tighten the bolts yet.
- Hold the caster in position, insert the carriage bolt heads into the slots near the front of the caster rail and slide the caster back.
- Insert the two (2) front carriage bolts thru the top side of the caster rail and then thru the front holes on the caster. Attach locking nuts to each.
- Tighten all locking nuts securely using a ½ inch end wrench or socket wrench (see Fig. 3).
- Repeat the same procedure for the other fixed caster.

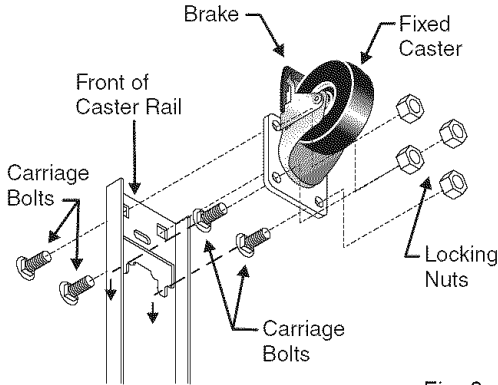

Fig. 3

## Rear Swivel Caster Installation

- Place a washer on a long bolt and then feed the bolt through the hole in the swivel caster.
- Next, insert the caster bolt through the hole on the metal spacer and then thru the rear hole of the caster rail (see Fig. 4).

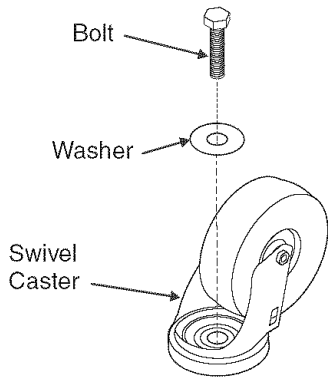

Fig. 4

## Caster Rail Installation

- Holding the swivel caster in place, align the caster rail assembly with the right hand bottom side of the unit.
- Thread the caster bolt into the hole in the bottom-most foot pad on the base rail.
- Tighten the bolt securely using a ½ inch end wrench or socket wrench (see Fig. 5).
- Repeat the same procedure on the left hand side with the other swivel caster and caster rail assembly. Fig. 6

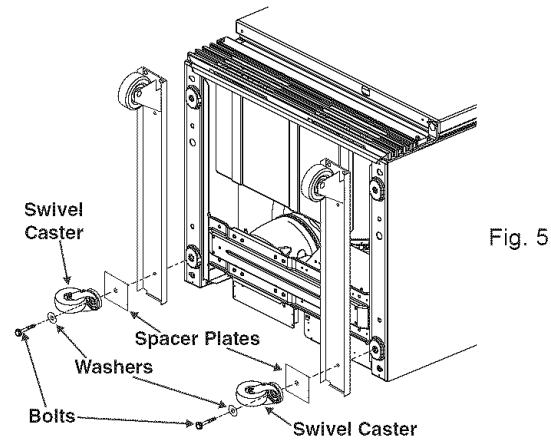

Fig. 5

- Place a washer onto a long bolt and slide bolt through the hole located just behind the fixed caster at the front of the caster rail.
- Align bolt with the hole in the front foot of the right hand base rail. Thread bolt into the hole and tighten securely using a ½ inch end wrench or socket wrench (see Fig. 6).
- Repeat the same procedure for the left hand caster rail assembly. After installation, tip the unit up with the help of an assistant.

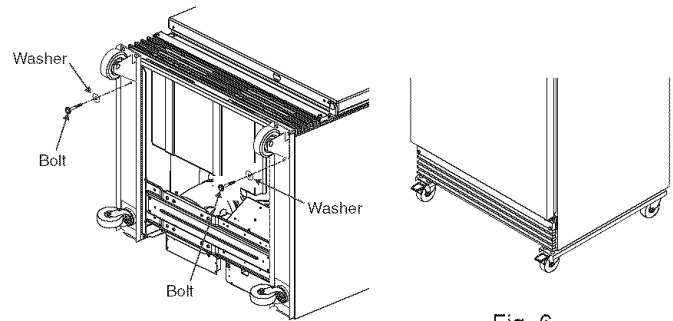

Fig. 6

## Appliance Placement

Leave a one (1) inch space on all sides and the back of the cabinet for ease of installation, proper air circulation and electrical connections. **DO NOT block the front grill on the lower front of your appliance.** Sufficient air circulation is essential for the proper operation of your appliance. Choose a place that is near a grounded electrical outlet. For the most efficient operation, the appliance should be located where surrounding temperatures will not drop below 40°F (5°C) or exceed 110°F (43°C). Additional compressor heaters are not recommended.

## Insulation

The insulated space on this cabinet is sealed to maintain peak efficiency. DO NOT drill holes in the cabinet. Holes drilled in the cabinet may destroy that seal and damage electrical wiring located in the insulated space. It may also pierce and damage the sealed refrigeration system in the insulated space.

**DAMAGED ELECTRICAL WIRING OR WET INSULATION CAUSED BY DRILLING WILL VOID THE WARRANTY.**

## Appliance Start-up

Once the appliance has been located in its permanent location and the proper power and grounding has been provided, the following items must be checked or completed:

### Cool Down Period

For safe food storage, allow 24 hours for the appliance to cool down completely before loading with food. The appliance will run continuously for the first several hours. Do not place any food in the appliance until after the first 24 hours of operation.

### Thermostat Setting

The appliance is shipped from the factory with the thermostat set at about the mid-point of the operating range. Adjustments colder or warmer can be made after the appliance has been running for at least 8 hours. Allow at least 8 hours for temperature stabilization before re-adjusting the thermostat.

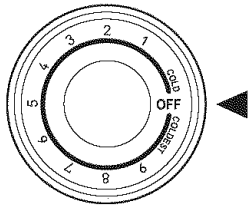

### Defrost Setting

The appliance is designed to defrost automatically every 12 hours. To set the time of defrost, wait until the desired time to defrost. With the notch on the timer knob aligned with the line on the bracket (Fig. A), turn the defrost timer knob clockwise slowly. The timer will click several times, then once loudly, at which point the defrost cycle begins. The timer knob will advance through the defrost cycle, then click loudly at the end of the cycle (Fig. B). The appliance will defrost automatically every 12 hours after the first defrost cycle.

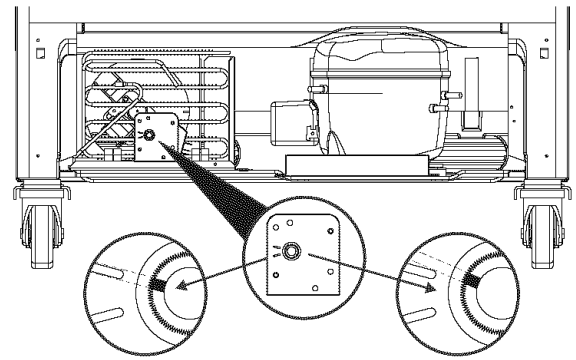

Fig. A  
Position of knob before turning clockwise to start defrost cycle (First click)

Fig. B  
Position of knob at end of defrost cycle (Second click)

## Features

### NSF and FDA Approved Adjustable Shelving

This appliance is provided with NSF and FDA approved heavy duty epoxy powder coated adjustable shelves. The one with the wires that are angled on the front and back goes on the floor of the cabinet. The others are placed in the adjustable stainless steel shelf supports that clip into the shelf support strips on each side of the interior. Make sure to place the shallow shelf in the upper-most position.

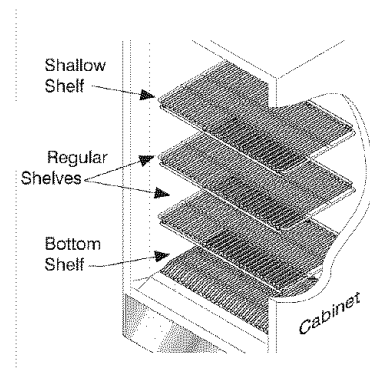

### Front Fixed and Rear Swivel Casters

This appliance comes with two (2) front fixed casters with brakes and two (2) rear swivel casters. The casters allow the appliance to be moved with ease and then locked in position at its desired location.

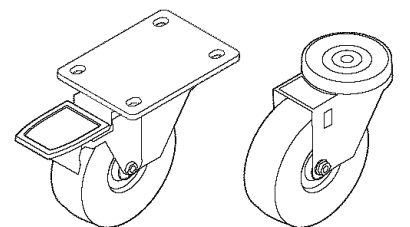

Fixed Caster

Swivel Caster

## Adjustable Temperature Control

The adjustable cold control is located on the top left side of the evaporator housing inside the unit. "5" is the medium (recommended) setting and "9" is the coldest setting.

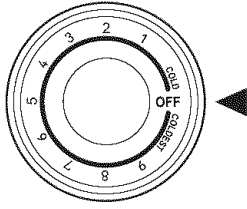

## NSF Certified Temperature Gauge

This appliance is equipped with an NSF certified temperature gauge to display cabinet internal temperature. The temperature gauge is located on the top right side of the evaporator housing inside the unit.

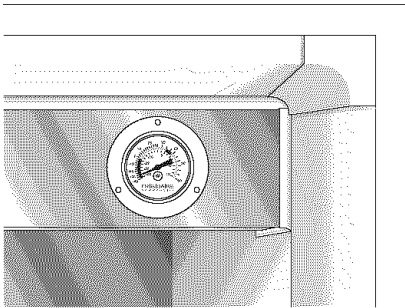

## Fluorescent Lamp (Glass Door Models)

The Glass Door Refrigerator is equipped with a 17 watt fluorescent lamp. A ballast – lamp mismatch may result in poor or no lighting.

If the lamp fails, replace with a lamp of the same type and wattage. Also, replace a lamp that flickers continuously. This could damage the ballast.

Turning the light off, when not in use, will save energy. However, frequent ON-OFF cycling will reduce the lamp life.

Use only NSF certified lamp which can be ordered from your Frigidaire Commercial Service Center by calling 1-866-738-1640.

## Interior Light (Stainless Steel Door Models)

The Stainless Steel Door models are equipped with a 40 watt bulb that lights up when the door is opened. If the bulb goes bad, replace with bulb of the same type and wattage. This is a special bulb with a shatterproof coating. Use only an NSF certified bulb of the same type and wattage which can be ordered from your Frigidaire Commercial Service Center by calling 1-866-738-1640.

## Other Features

- NSF Certified top mounted evaporator.
- 2 ½ thick urethane foam cabinet insulation.
- Torsion spring door closer (Glass Door models).
- Stainless steel evaporator housing.
- Removable stainless steel drain cover.
- Heavy duty front grill.
- Heavy duty commercially rated electrical harness.
- Heavy duty removable stainless steel shelf supports.

## Routine Maintenance

### Cleaning the Interior

Be sure to turn the temperature control to "OFF" and unplug the electrical cord. Wash the inside surface of the storage area with warm water and baking soda solution (about one tablespoon of baking soda per quart of warm water). Rinse thoroughly with clean, warm water and wipe dry.

### Cleaning the Exterior

Wipe the cabinet exterior occasionally with a cloth dampened in mild detergent and water. Rinse and wipe dry with a soft cloth. Do not use razor blades or other sharp instruments that can scratch the appliance surface when removing adhesive labels. Any glue left from the tape can be removed with a mixture of warm water and mild detergent or touch the residue with the sticky side of tape already removed. **DO NOT REMOVE THE SERIAL PLATE.**

### Condensate Pan

Some models have a condensate pan in a fixed position located behind the toe grill. This must not be removed from under the cabinet. If the pan is removed, condensate will drop onto the floor.

## POWER FAILURE

**DO NOT** open the appliance lid unnecessarily if the appliance is off for several hours.

If a power failure occurs, pack seven or eight pounds of dry ice into the appliance every 24 hours. Look in the Yellow Pages under "Dry Ice", "Dairies", or "Ice Cream Manufacturers" for local dry ice suppliers. Always wear gloves and use caution when handling dry ice.

## Energy Conservation Measures

This appliance is designed for efficiency with heavy foam insulation. However, there are things that the user can do to maintain the appliance in operating condition.

- Do not operate the appliance any colder than necessary to maintain safe, product storage temperatures.
- Make sure the appliance is located to prevent direct exposure to sunlight, air ducts, etc.
- Keep the door closed except for normal use. Inspect the door often to see that it self-closes and the gaskets are in good condition.
- Do not overstock the product in the cabinet because it will block the normal air flow.
- Have at least annual inspections by a qualified service company to see that the refrigerant charge is correct.
- This appliance operates more efficiently in a cooler ambient than in a hot ambient. Try to maintain an ambient below 80°F (27°C) and 65% RH (Relative Humidity) for maximum efficiency.

### Periods of Non-use and Moving Tips

Leave the appliance operating during periods of non-use of less than three (3) weeks.

#### Long Periods of Non-use

If the appliance will not be used for several months:

- Remove all food and unplug the power cord.
- Clean and dry the interior thoroughly.
- Leave the appliance door open slightly, blocking it open if necessary, to prevent odor and mold growth.

#### Moving

When moving the appliance, follow these guidelines to prevent damage:

- Disconnect the power cord plug from the wall outlet.
- Remove foods, then defrost, and clean the appliance.
- Secure all loose items such as base panel, baskets, and shelves by taping them securely in place to prevent damage.
- In the moving vehicle, secure appliance in an upright position to prevent movement. Also, protect outside of appliance with a blanket or similar item.

<b>TROUBLESHOOTING GUIDE</b>		
	Before calling for service, review this list. It may save you time and expense. This list includes common occurrences that are not the result of defective workmanship or materials in this appliance.	
<b>PROBLEM</b>	<b>CAUSE</b>	<b>CORRECTION</b>
<b>APPLIANCE OPERATION</b>		
Appliance does not run.	* Appliance is plugged into a circuit that has a ground fault	* Use another circuit. If you are unsure about the outlet, have it checked by a certified technician.
	* Temperature control is in the "OFF" position.	* See Thermostat Setting.
	* Appliance may not be plugged in, or plug may be loose.	* Ensure plug is tightly pushed into outlet.
	* House fuse blown or tripped circuit breaker.	* Check/replace fuse with a 15 amp time delay fuse. Reset circuit breaker.
	* Power outage	* Check house lights. Call local Electric Company.
Appliance runs too much or too long.	* Room or outside weather is hot.	* It's normal for the appliance to work harder under these conditions.
	* Appliance has recently been disconnected for a period of time.	* It takes 24 hours for the appliance to cool down completely.
	* Large amount of warm or hot food have been stored recently.	* Warm food will cause appliance to run more until the desired temperature is reached.
	* Door is opened too frequently or kept open too long.	* Warm air entering the appliance causes it to run more. Open the door less often.
	* Appliance door may be slightly	* See "Door Problems".
	* Temperature control is set too low.	* Turn control knob to a warmer setting. Allow several hours for the temperature to stabilize.
	* Appliance gaskets are dirty, worn, cracked or poorly fitted.	* Clean or change gasket. Leaks in the lid seal will cause appliance to run longer in order to maintain desired temperature.
Interior appliance temperature is too cold.	* Temperature control is set too low.	* Turn control knob to a warmer setting. Allow several hours for the temperature to stabilize.
Interior appliance temperature is too warm.	* Temperature control is set too warm.	* Turn control knob to a colder setting. Allow several hours for the temperature to stabilize.
	* Door is opened too frequently or kept open too long.	* Warm air entering the appliance causes it to run more. Open the door less often.
	* Appliance door may be slightly	* See "Door Problems".
	* Large amount of warm or hot food have been stored recently.	* Wait until the appliance has had a chance to reach its selected temperature.
	* Appliance has recently been disconnected for a period of time.	* appliance requires 24 hours to cool down completely.
Appliance external surface temperature is warm.	* The external appliance walls can be as much as 30°F warmer than room temperature.	* This is normal while the compressor works to transfer heat from inside the appliance cabinet.
<b>SOUND AND NOISE</b>		
Louder sound levels whenever appliance is on.	* Modern appliances have increased storage capacity and more stable temperatures. They require heavy duty compressors.	* This is normal. When the surrounding noise level is low, you might hear the compressor running while it cools the interior.
Louder sound levels when compressor comes on.	* Appliance operates at higher pressures during the start of the ON cycle.	* This is normal. Sound will level off or disappear as appliance continues to run.
Popping or cracking sound when compressor comes on.	* Metal parts undergo expansion and contraction, as in hot water pipes.	* This is normal. Sound will level off or disappear as appliance continues to run.

<b>PROBLEM</b>	<b>CAUSE</b>	<b>CORRECTION</b>
<b><i>SOUND AND NOISE (Cont.)</i></b>		
Bubbling or gurgling sound	* Refrigerant (used to cool appliance) is circulating	* This is normal.
Vibrating or rattling noise.	* Appliance is not level. It rocks on the floor when it is moved	* Level the appliance by putting wood or metal shims under part of the appliance.
	* Floor is uneven or weak.	* Ensure floor can adequately support appliance. Level the appliance by putting wood or metal shims under part of the appliance.
	* appliance is touching the wall.	* Re-level appliance or move appliance slightly.
<b><i>WATER / MOISTURE / FROST INSIDE APPLIANCE</i></b>		
Moisture forms on inside appliance walls.	* Weather is hot and humid, which increases internal rate of frost build-up.	* This is normal.
	* Door is slightly open.	* See "Door Problems".
	* Door is kept open too long or is opened too frequently.	* Open the door less often.
<b><i>ODOR IN APPLIANCE</i></b>		
Odors in appliance.	* Interior needs to be cleaned.	* Clean interior with sponge, warm water, and baking soda.
	* Foods with strong odors are in the appliance.	* Cover the food tightly.
<b><i>DOOR PROBLEMS</i></b>		
Door will not close.	* Appliance is not level. It rocks on the floor when it is moved slightly.	* Level the appliance by putting wood or metal shims under part of the appliance.
	* Floor is uneven or weak.	* Ensure floor can adequately support appliance. Level the appliance by putting wood or metal shims under part of the appliance.
<b><i>LIGHTING PROBLEMS</i></b>		
Light bulb is not on.	* The fluorescent lamp or light bulb is burned out.	* See "Fluorescent Lamp" or "Interior Light" on Features Section.
	* No electric current is reaching the appliance.	* See "appliance Does Not Run".

# IMPORTANT SAFETY NOTICE

The information provided herein is designed to assist qualified repair personnel only. Untrained persons should not attempt to make repairs due to the possibility of electrical shock. Disconnect the power cord before servicing.

## ELECTRICAL CIRCUIT

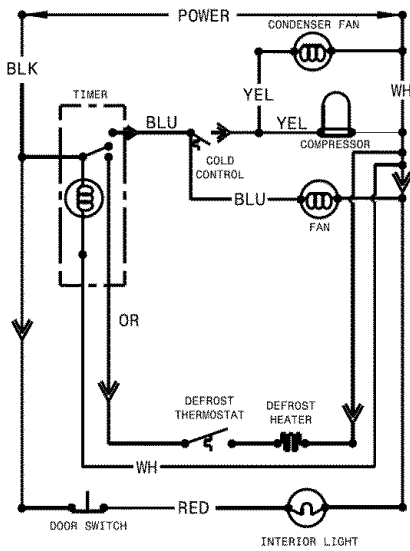

**STAINLESS STEEL DOOR REFRIGERATOR**

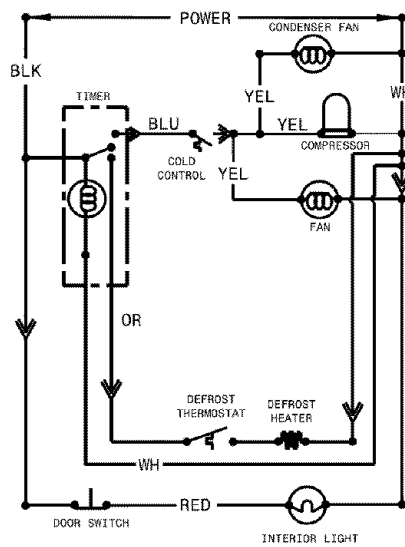

**STAINLESS STEEL DOOR FREEZER**

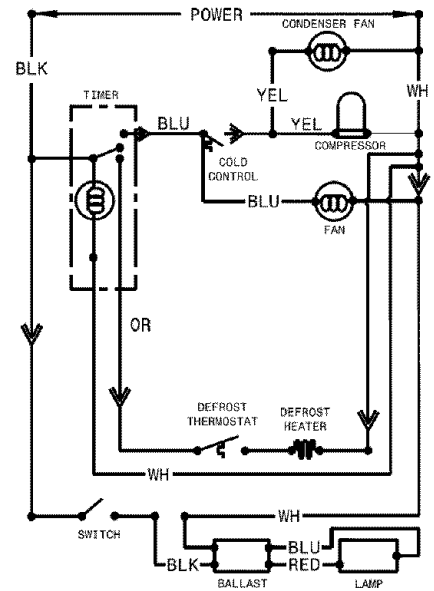

**GLASS DOOR REFRIGERATOR**

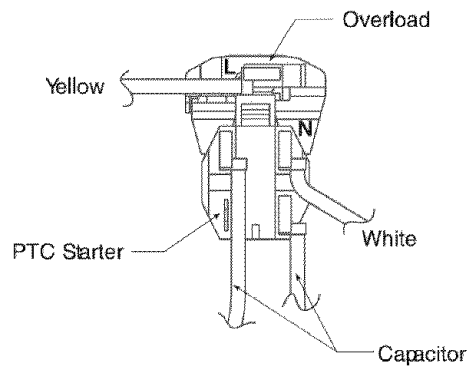
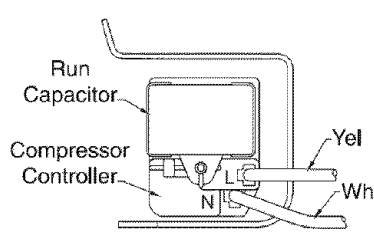

## IMPORTANT

**IF ANY GREEN GROUNDING WIRES ARE REMOVED DURING SERVICING, THEY MUST BE RETURNED TO THEIR ORIGINAL POSITION AND PROPERLY SECURED.**

# Commercial Appliance Warranty Information

Your appliance is covered by a one year limited warranty. For one year from your original date of purchase, Electrolux will pay all costs for repairing or replacing any parts of this appliance that prove to be defective in materials or workmanship when such appliance is installed, used and maintained in accordance with the provided instructions.

**Exclusions      This warranty does not cover the following:**

1. All labor costs on commercial laundry products.
2. Payment acceptance devices for commercial laundry products.
3. Products with original serial numbers that have been removed, altered or cannot be readily determined.
4. Normal wear and tear and gradual deterioration.
5. Product that has been transferred from its original owner to another party or removed outside the USA or Canada.
6. Rust on the interior or exterior of the unit.
7. Products purchased "as-is".
8. Food loss due to any refrigerator or freezer failures.
9. Damage caused at any time during shipment.
10. Service calls which do not involve malfunction or defects in materials or workmanship, or for appliances used other than in accordance with the provided instructions.
11. Service calls to correct the installation of your appliance or to instruct you how to use your appliance.
12. Expenses for making the appliance accessible for servicing, such as removal of trim, cupboards, shelves, etc., which are not a part of the appliance when it is shipped from the factory.
13. Service calls to replace appliance light bulbs, air filters, water filters, other consumables, or knobs, handles, or other cosmetic parts.
14. Surcharges including, but not limited to, any after hour, weekend, or holiday service calls, tolls, ferry trip charges, or mileage expense for service calls to remote areas, including the state of Alaska.
15. Damages to the finish of appliance and/or location that are incurred during installation, including but not limited to floors, cabinets, walls, etc.
16. Damages caused by: services performed by unauthorized service companies; use of parts other than genuine Electrolux parts or parts obtained from persons other than authorized service companies; or external causes such as abuse, misuse, inadequate power supply, accidents, fires, or acts of God.
17. Labor costs after ninety (90) days from your original date of purchase incurred for product repair or replacement as provided herein for appliances operated by a concessionaire or vendor in a trailer or other motorized vehicle or at varying locations.

**DISCLAIMER OF IMPLIED WARRANTIES; LIMITATION OF REMEDIES**

CUSTOMER'S SOLE AND EXCLUSIVE REMEDY UNDER THIS LIMITED WARRANTY SHALL BE PRODUCT REPAIR OR REPLACEMENT AS PROVIDED HEREIN. CLAIMS BASED ON IMPLIED WARRANTIES, INCLUDING WARRANTIES OF MERCHANTABILITY OR FITNESS FOR A PARTICULAR PURPOSE, ARE LIMITED TO ONE YEAR OR THE SHORTEST PERIOD ALLOWED BY LAW, BUT NOT LESS THAN ONE YEAR. ELECTROLUX SHALL NOT BE LIABLE FOR CONSEQUENTIAL OR INCIDENTAL DAMAGES SUCH AS PROPERTY DAMAGE AND INCIDENTAL EXPENSES RESULTING FROM ANY BREACH OF THIS WRITTEN LIMITED WARRANTY OR ANY IMPLIED WARRANTY. SOME STATES AND PROVINCES DO NOT ALLOW THE EXCLUSION OR LIMITATION OF INCIDENTAL OR CONSEQUENTIAL DAMAGES, OR LIMITATIONS ON THE DURATION OF IMPLIED WARRANTIES, SO THESE LIMITATIONS OR EXCLUSIONS MAY NOT APPLY TO YOU. THIS WRITTEN WARRANTY GIVES YOU SPECIFIC LEGAL RIGHTS. YOU MAY ALSO HAVE OTHER RIGHTS THAT VARY FROM STATE TO STATE.

**If You Need Service**

Keep your receipt, delivery slip, or some other appropriate payment record to establish the warranty period should service be required. If service is performed, it is in your best interest to obtain and keep all receipts. Service under this warranty must be obtained by contacting Electrolux at the addresses or phone numbers below.

This warranty only applies in the USA and Canada. In the USA, your appliance is warranted by Electrolux Major Appliances North America, a division of Electrolux Home Products, Inc. In Canada, your appliance is warranted by Electrolux Canada Corp. Electrolux authorizes no person to change or add to any obligations under this warranty. Obligations for service and parts under this warranty must be performed by Electrolux or an authorized service company. Product features or specifications as described or illustrated are subject to change without notice.

**USA**  
**1.866.738.1640**  
Electrolux Major Appliances  
North America  
P.O. Box 212378  
Augusta, GA 30907



**Canada**  
**1.866.738.1640**  
Electrolux Canada Corp.  
5855 Terry Fox Way  
Mississauga, Ontario, Canada  
L5V 3E4

