

SEARS

owner's manual

Model
C950-52935-1

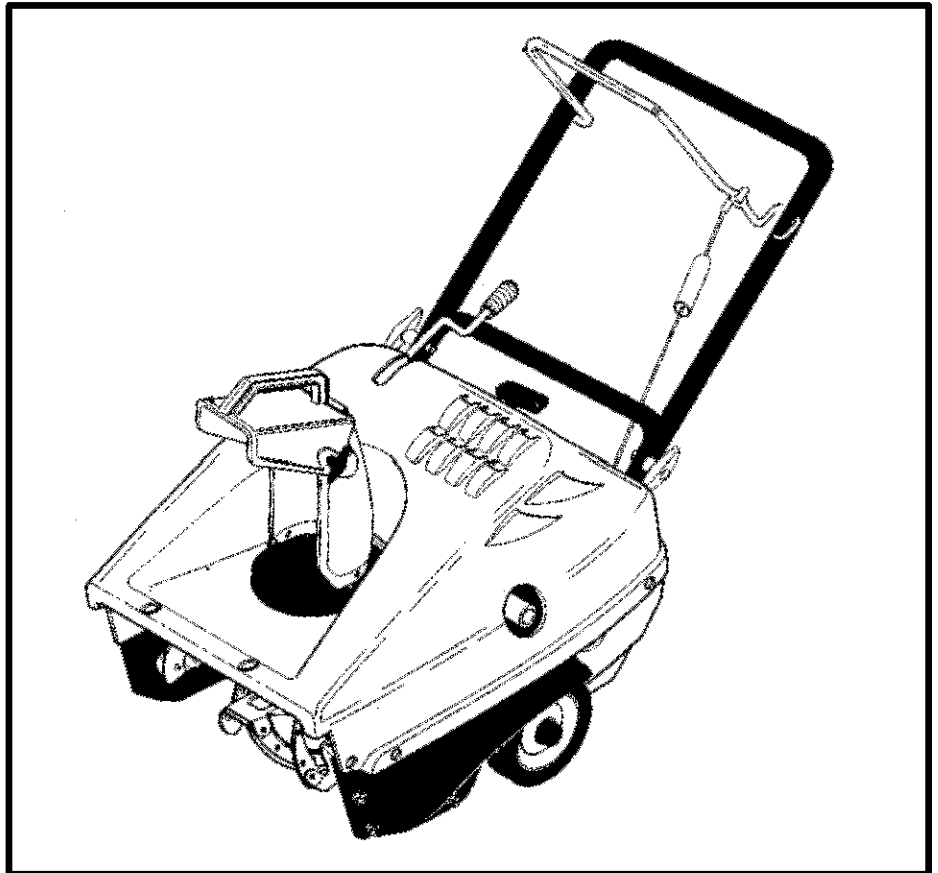

CRAFTSMAN

5.0 Horsepower
21 Inch Single Stage
Auger Propelled
Electric Start
SNOW THROWER

CAUTION:

You must read and understand this owner's manual before operating unit.

Serial No. _____

- Assembly
- Operation
- Customer Responsibilities
- Service and Adjustment
- Repair Parts

RULES FOR SAFE OPERATION

IMPORTANT



WARNING: Always disconnect the spark plug wire and place it where it cannot make contact with spark plug to prevent accidental starting during: Preparation, Maintenance, or Storage of your snow blower.



SAFE OPERATION PRACTICES FOR WALK-BEHIND SNOW BLOWER DO NOT OPERATE THIS EQUIPMENT BEFORE READING THIS MANUAL



WARNING:



Engine Exhaust, some of its constituents, and certain vehicle components contain or emit chemicals known to the State of California to cause cancer and birth defects or other reproductive harm.

Battery posts, terminals and related accessories contain lead and lead compounds, chemicals known to the State of California to cause cancer and birth defects or other reproductive harm. WASH HANDS AFTER HANDLING.

TRAINING

1. Read the operating and service instruction manual carefully. Be thoroughly familiar with the controls and the proper use of the equipment. Know how to stop the unit and disengage the controls quickly.
2. Never allow children to operate the equipment. Never allow adults to operate the equipment without proper instruction.
3. Keep the area of operation clear of all persons, particularly small children and pets.
4. Exercise caution to avoid slipping or falling especially when operating in reverse.

PREPARATION

1. Thoroughly inspect the area where the equipment is to be used and remove all doormats, sleds, boards, wires, and other foreign objects.
2. Disengage all clutches before starting the engine.
3. Do not operate the equipment without wearing adequate winter outer garments. Wear footwear that will improve footing on slippery surfaces.
4. Handle fuel with care; it is highly flammable.
 - (a) Use an approved fuel container.
 - (b) Never add fuel to a running engine or hot engine.

(c) Fill fuel tank outdoors with extreme care. Never fill fuel tank indoors.

(d) Replace gasoline cap securely and wipe up spilled fuel.

5. For all units with electric starting motors use electric starting extension cords certified CSA/UL. Use only with a receptacle that has been installed in accordance with local inspection authorities.
6. Adjust the auger housing height to clear gravel or crushed rock surface.
7. Under no circumstances should any adjustments be made while the engine is running (except when specifically recommended by manufacturer).
8. Let engine and machine adjust to outdoor temperatures before starting to clear snow.
9. Always wear safety glasses or eye shields during operation or while performing an adjustment or repair to protect eyes from foreign objects that may be thrown from the machine.

OPERATION



1. Do not put hands or feet near or under rotating parts. Keep clear of the discharge opening at all times.
2. Exercise extreme caution when operating on or crossing gravel drives, walks or roads. Stay alert for hidden hazards or traffic.
3. Never discharge snow onto public roads or near moving traffic.
4. After striking a foreign object, stop the engine, remove the wire from the spark plug, thoroughly inspect snow blower for any damage, and repair the damage before re-starting and operating the snow blower.
5. If the unit should start to vibrate abnormally, stop the engine and check immediately for the cause. Vibration is generally a warning of trouble.
6. Stop the engine and remove spark plug wire whenever you leave the operating position, before unclogging the auger/impeller housing or discharge chute and when making any repairs, adjustments, or inspections.
7. When cleaning, repairing, or inspecting, make certain the auger/impeller and all moving parts have stopped and all controls are disengaged. Disconnect the spark plug wire and keep the wire away from the spark plug to prevent accidental starting.

RULES FOR SAFE OPERATION

8. Take all possible precautions when leaving the snow blower unattended. Disengage the auger/ impeller, shift to neutral, stop engine, and remove key.
9. Do not run the engine indoors, except when starting the engine and for transporting the snow blower in or out of the building. Ensure the outside doors are open; exhaust fumes are dangerous.
10. Do not clear snow across the face of slopes. Exercise extreme caution when changing direction on slopes. Do not attempt to clear steep slopes.
11. Never operate the snow blower without proper guards, plates or other safety protective devices in place.
12. Never operate the snow blower near enclosures, automobiles, window wells, drop-offs, and the like without proper adjustment of the snow discharge angle. Keep children and pets away.
13. Do not overload the machine capacity by attempting to clear snow at too fast a rate.
14. Never operate the machine at high transport speeds on slippery surfaces. Look behind and use care when backing up.
15. Never direct discharge at bystanders or allow anyone in front of the unit.
16. Disengage power to the collector/impeller when snow blower is transported or not in use.
17. Use only attachments and accessories approved by the manufacturer of the snow blower (such as wheel weights, counterweights, cabs, and the like).
18. Never operate the snow blower without good visibility or light. Always be sure of your footing and keep a firm hold on the handles.
19. Do not over-reach. Keep proper footing and balance at all times.
20. Do not attempt to use snow blower on a roof.

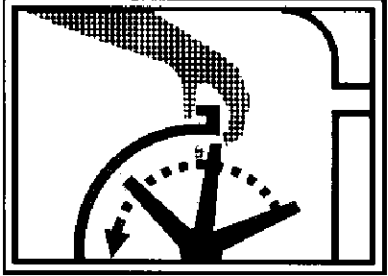

MAINTENANCE AND STORAGE

1. Check shear bolts and other bolts at frequent intervals for proper tightness to be sure the equipment is in safe working condition.
2. Never store the machine with fuel in the tank inside a building where ignition sources are present such as hot water and space heaters, clothes dryers, and the like. Allow the engine to cool before storing in any enclosure.
3. Always refer to operator's guide instructions for important details if the snow blower is to be stored for an extended period.
4. Maintain or replace safety and instruction labels, as necessary.
5. Run the machine 2 minutes with auger clutch lever engaged after blowing snow to prevent freeze-up of the auger/impeller.



WARNING: Do not use hands to unclog discharge chute.

- Stop engine/motor before removing debris.
- Do not walk in front of running machine.
- Do not discharge at bystanders.
- Keep people and pets a safe distance from the machine.
- Before leaving machine, shut off engine/ motor and remove key.



WARNING: Avoid injury from rotating auger— keep hands, feet, and clothing away.

OWNER'S INFORMATION

DATE PURCHASED: _____
MODEL NO: _____
SERIAL NO: _____
STORE WHERE PURCHASED: _____
ADDRESS: _____
CITY: _____ PROVINCE: _____
TELEPHONE : _____

Record this information about your unit so that you will be able to provide it in case of loss or theft.

Horse Power	5 HP
Gasoline Capacity	1.62 quarts (1.53 litre)
Fuel/Oil Mix Ratio	40:1 (3.2 ounces of air-cooled 2-cycle engine oil specified for 40:1 ratio per 1 gallon gasoline)
Spark Plug	Champion RJC8Y Gap 0.030 in.

MAINTENANCE AGREEMENT

The Craftsman Warranty, plus a Maintenance Agreement, provide maximum value for Sears products. Contact your nearest Sears store for details.

CUSTOMER RESPONSIBILITIES

Read and observe the safety rules.

Follow a regular schedule in maintaining, caring for and using your snow blower.

Follow the instructions under "Customer Responsibilities" and "Storage" sections of this owner's manual.

WHEELED SNOW BLOWER

LIMITED TWO (2) YEAR WARRANTY ON CRAFTSMAN SNOW BLOWER

For two (2) years from date of purchase, Sears Canada Inc. will repair or replace free of charge, at Sears option, parts which are defective as a result of material or workmanship.

COMMERCIAL OR RENTAL USE:

Warranty on snow blower will be 90 days from date of purchase if used for commercial or rental purposes.

THIS WARRANTY DOES NOT COVER:

1. Pre-delivery set-up.
2. Expendable items which become worn during normal use, such as belts, spark plugs, filter, shear pins as well as damages to the engine resulting from operating the snow blower with insufficient oil.
3. Tire replacement or repair caused by punctures from outside objects, such as nails, thorns, stumps or glass.
4. In home service.

Warranty service is available by returning the Craftsman snow blower to the nearest Sears Service Centre/Department in Canada. This warranty applies only while this product is in use in Canada.

This warranty is in addition to any statutory warranty and does NOT exclude or limit legal rights you may have but shall run concurrently with applicable provincial legislation. Furthermore, some provinces do not allow limitations on how long an implied warranty will last so the above limitations may not apply to you.

SEARS CANADA INC., TORONTO, ONTARIO M5B 2B8

TABLE OF CONTENTS

RULES FOR SAFE OPERATION	2
OWNER'S INFORMATION	4
ASSEMBLY	6
PARTS BAGS CONTENTS:	6
TOOLS REQUIRED FOR ASSEMBLY	6
HOW TO REMOVE FROM THE CARTON	6
HOW TO ASSEMBLE THE HANDLE	6
N CHECKLIST	6
OPERATION	7
ENGINE AND SNOW THROWER OPERATING CONTROLS	7
SNOW BLOWER OPERATION	8
HOW TO STOP THE SNOW THROWER	8
TO CONTROL SNOW DISCHARGE	8
HOW TO THROW SNOW	8
HOW TO MOVE FORWARD	8
SERVICE RECOMMENDATIONS	12
CUSTOMER RESPONSIBILITIES	13
HOW TO REMOVE THE TOP COVER	13
HOW TO REMOVE THE BELT COVER	13
ADJUSTMENT/REPAIR	14
HOW TO ADJUST THE CHUTE CRANK	14
HOW TO ADJUST THE AUGER CONTROL CABLE	14
HOW TO SET THE DRIVE BELT TENSION	15
HOW TO SET REPLACE THE DRIVE BELT	15
HOW TO REPLACE THE AUGER	16
HOW TO ADJUST THE CARBURETOR	17
HOW TO ADJUST OR REPLACE THE SPARK PLUG	17
STORAGE	18
TROUBLE SHOOTING CHART	19



ASSEMBLY

PARTS BAGS CONTENTS:

- 1 – 3.2 ounces Craftsman 2-cycle oil
- 1 – Owner's Manual
- 1 – Starter Cord

TOOLS REQUIRED FOR ASSEMBLY

- 1-Knife



WARNING: Always wear safety glasses or eye shields while assembling snowblower.

Figure 1 shows the snow thrower in the operating position.

References to the right or left hand side of the snow thrower are from the viewpoint of the operator's position behind the unit.

HOW TO REMOVE FROM THE CARTON

1. Locate and remove container of Craftsman 2-cycle oil.
2. Locate all parts packed separately and remove from the carton.
3. Remove and discard the packing material from around the snow thrower.
4. Cut down all four corners of the carton and lay the panels flat.
5. Hold onto the lower handle and pull the snow thrower off the carton.

CAUTION: DO NOT back over cables.

6. Remove the packing material from the handle assembly.

HOW TO ASSEMBLE THE HANDLE

1. Loosen the **knobs** on each side of the **handle** (Figure 1).
2. Raise the upper **handle** to the operating position. Hold the upper **handle** apart to prevent scratching the lower handle.

NOTE: Make sure the cables are not caught between the upper and lower handle.

3. Tighten the **knobs**.

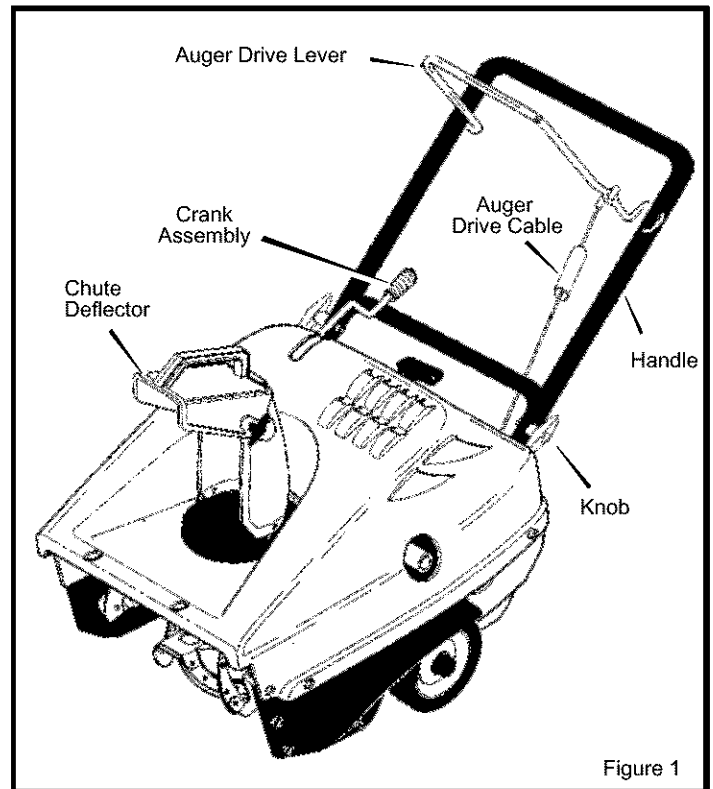

Figure 1

✓ CHECKLIST

Before you operate your new snow thrower, to ensure that you receive the best performance and satisfaction from this quality product, please review the following checklist:

- ✓ All assembly instructions have been completed.
- ✓ The discharge chute rotates freely.
- ✓ No remaining loose parts in carton.

While learning how to use your snow thrower, pay extra attention to the following important items:

- ✓ Make sure the fuel tank is filled with the correct mixture (40:1 ratio) of gasoline and oil.
- ✓ Become familiar with the location of all controls and understand their function.
- ✓ Before starting the engine, make sure all controls operate correctly.

OPERATION

KNOW YOUR SNOW THROWER

READ THIS OWNER'S MANUAL AND SAFETY RULES BEFORE OPERATING YOUR SNOW THROWER. Compare the illustrations with your SNOW THROWER to familiarize yourself with the location of various controls and adjustments. Save this manual for future reference.

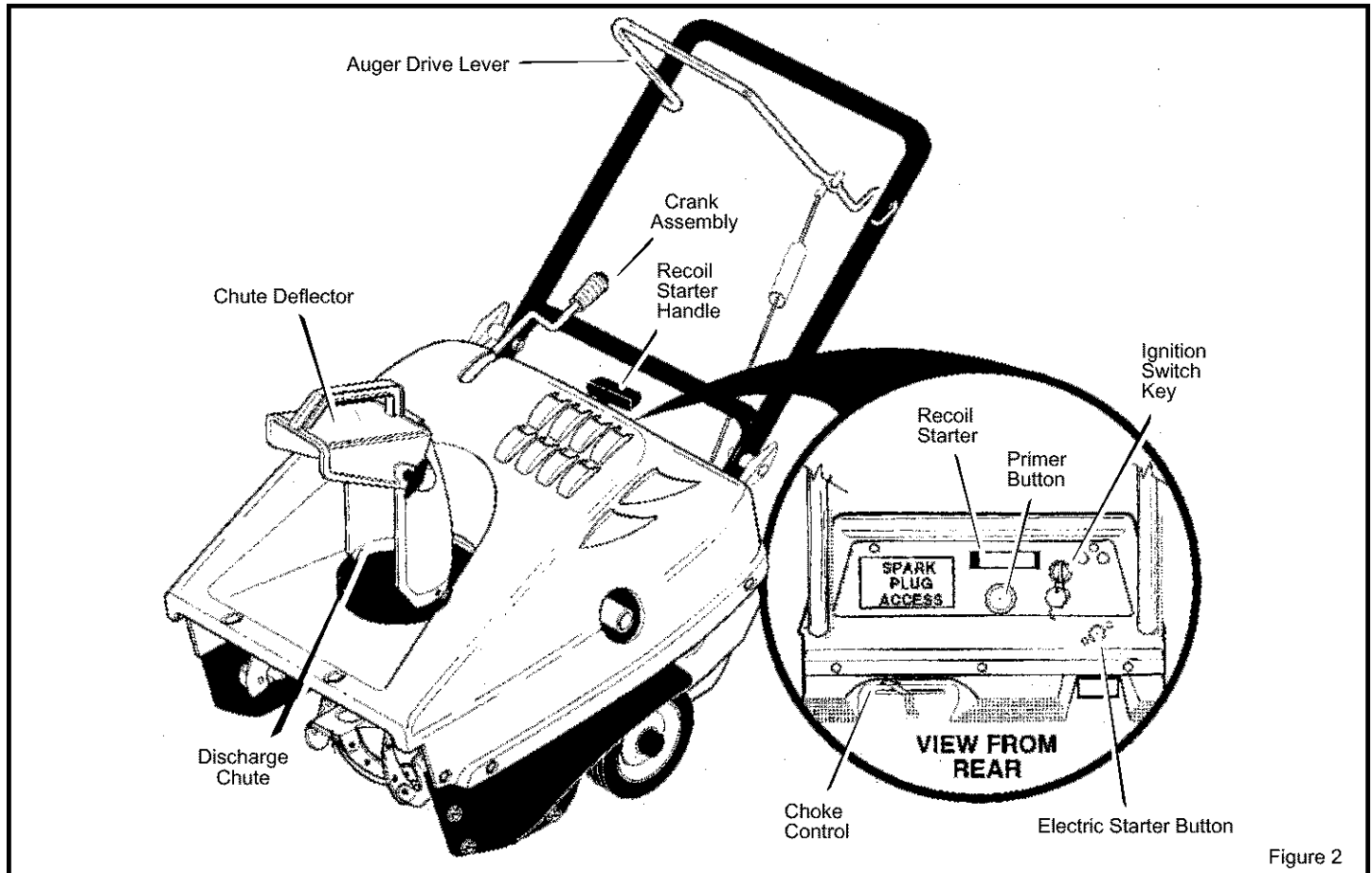

Figure 2

ENGINE AND SNOW THROWER OPERATING CONTROLS

The engine operating controls and their functions are as follows:

Auger Drive Lever – Starts and stops the auger.

Crank Assembly – Changes the direction of snow throwing through the discharge chute.

Chute Deflector – Changes the distance the snow is thrown.

Discharge Chute – Changes the direction the snow is thrown.

Ignition Switch Key – Must be inserted and turned to the ON position to start the engine.

Recoil Starter Handle – Starts the engine manually.

Electric Starter Button – Use to start the engine when using the 120V electric starter.

Choke Control – Used to start a cold engine.

Primer Button – Injects fuel directly into the carburetor manifold for fast starts in cold weather.

Spark Plug Access Panel – Aides in the removal of the spark plug.

OPERATION



The operation of any snow blower can result in foreign objects being thrown into the eyes, which can result in severe eye damage. Always wear safety glasses or eye shields before beginning snow blower operation. We recommend standard safety glasses or Wide Vision Safety Mask for over spectacles.

SNOW BLOWER OPERATION

The most effective use of the snow blower will be established by experience, taking into consideration the terrain, wind conditions and building location which will determine the direction of the discharge chute.

NOTE: Do not discharge snow toward a building as hidden objects could be thrown with sufficient force to cause damage.



WARNING: Read Owner's Manual before operating machine. This machine can be dangerous if used carelessly.

Never operate the snow blower without all guards, covers, and shields in place.

Never direct discharge toward windows or allow bystanders near machine while engine is running.

Stop the engine whenever leaving the operating position.

Disconnect spark plug before unclogging the impeller housing or the discharge chute and before making repairs or adjustments.

When leaving the machine, remove the ignition key.

To reduce the risk of fire, keep the machine clean and free from spilled gas, oil and debris.

HOW TO STOP THE SNOW THROWER

1. To stop throwing snow, release the **auger drive lever**. (See Figure 4).

HOW TO THROW SNOW

1. Engage the **auger drive lever**. (See Figure 4).
2. To stop throwing snow, release the **auger drive lever**.

HOW TO MOVE FORWARD

3. Hold the **auger drive lever** against the **handle** (See Figure 4). The auger will begin rotating.
4. To go forward, raise the **handle** to allow the **rubber auger blades** to contact the ground. Maintain a firm hold on the **handle** as the snow thrower starts to move forward. Guide the snow thrower by moving the **handle** either left or right. Do not attempt to push the snow thrower.
5. To stop, release the **auger drive lever**.

NOTE: If the snow thrower continues to slowly move forward, see "How To Adjust The Auger Control Cable" in the Service And Adjustment Section.

2. To stop the engine, move the **ignition key** to the OFF position.

TO CONTROL SNOW DISCHARGE

1. Turn the **chute control rod** to set the direction of the snow throwing.
2. Loosen the **wing knob** on the chute deflector and move the deflector to set the distance. Move the deflector (**Up**) for more distance, (**Down**) for less distance. Then tighten the **wing knob** (See Figure 3).

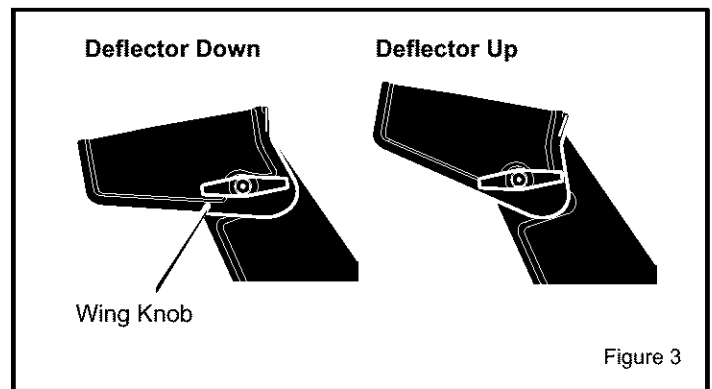

Figure 3

NOTE: If the auger continues to rotate, see "How To Adjust The Auger Control Cable" in the Service and Adjustments section.

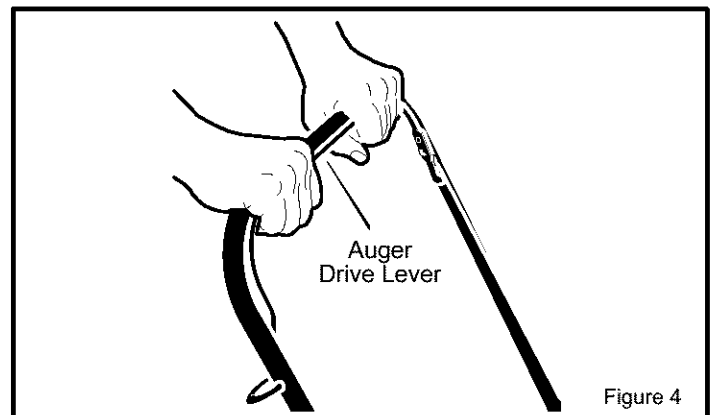

Figure 4

OPERATION

BEFORE STARTING THE ENGINE

WARNING: Experiences indicates that alcohol blended fuels (called gasohol or those using ethanol or methanol) can attract moisture which leads to separation and formation of acids during storage. Acidic gas can damage the fuel system of an engine while in storage.

NOTE: To avoid engine problems, the fuel system must be emptied before storage for 30 days or longer. Start the engine and let it run until the fuel lines and carburetor are empty. Use the carburetor bowl drain to empty residual gasoline from the float chamber. Use fresh fuel next season. See the Storage section in this manual for additional information.

Never use engine or carburetor cleaner products in the fuel tank or permanent damage can occur.

HOW TO MIX THE FUEL MIXTURE

The two cycle engine, used on this snow thrower, requires a mixture of gasoline and oil for lubrication of the bearings and other moving parts. The correct fuel mixture ratio is 40:1 (3.2 oz. oil per one gallon of gas – see the Fuel Mixture Chart). Gasoline and oil must be pre-mixed in a clean gasoline container. Always use fresh, clean, unleaded gasoline.

FUEL MIXTURE CHART (mixture 40:1)

U.S.		IMPERIAL		SI. (Metric)	
GAS	OIL	GAS	OIL	GAS	OIL
1 Gal.	3.2 oz.	1 Gal.	3.7 oz.	4 liter	100 ML

Mix gasoline and oil as follows:

1. Pour one (1) U.S. quart of fresh, clean, unleaded automotive gasoline into a one gallon size gasoline container.
2. Add 3.2 ounces of clean, high quality, two-cycle oil to the gasoline container.

IMPORTANT: Do not use outboard motor oil or multi-viscosity oils, such as 10W-30 or 10W-40.

3. Install the fuel cap onto the gasoline container. Vigorously shake the gasoline container to mix the oil with the gasoline.
4. Add an additional three (3) U.S. quarts of gasoline to the gallon container. Again shake the gasoline container.

WARNING: Gasoline is flammable. Always use caution when handling or storing gasoline. Do not fill fuel tank while snow thrower is running, when it is hot, or when snow thrower is in an enclosed area.

Keep away from open flame or an electrical spark and do not smoke while filling the fuel tank.

Never fill the tank completely. Fill the tank to within 1/4"–1/2" from the top to provide space for expansion of fuel.

Always fill fuel tank outdoors and use a funnel or spout to prevent spilling.

Make sure to wipe up any spilled fuel before starting the engine.

Store gasoline in a clean, approved container and keep the cap in place on the container.

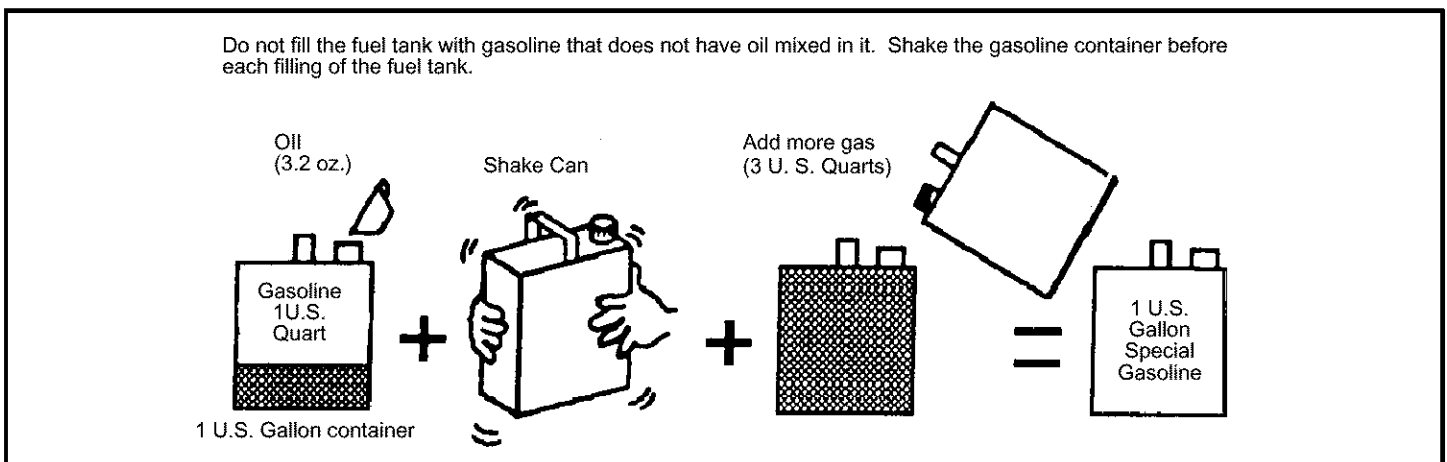

OPERATION

BEFORE STARTING THE ENGINE

1. Before you service or start the engine, familiarize yourself with the snow thrower. Be sure you understand the function and location of all controls.
2. Be sure that all fasteners are tight.
3. Before starting the engine, make sure all controls operate correctly.

HOW TO STOP THE ENGINE

To stop the engine, move the ignition key to the stop position.

HOW TO START THE ENGINE

The engine is equipped with a 120 volt AC electric starter and also a recoil starter. Before starting the engine, make certain that you have read the following information.

 **The starter is equipped with a three-wire power cord and plug and is designed to operate on 120 volt A.C. household current. The power cord must be properly grounded at all times to avoid the possibility of electrical shock which can injure the operator. Carefully follow all instructions in the "How To Start The Engine" section. Make sure that your house wiring is a three-wire grounded system. If you are not sure, ask a licensed electrician. If your house wire system is not a three-wire grounded system, do not use this electric starter under any conditions. If your system is grounded but a three-hole grounded receptacle is not available to start the engine, have a three-hole grounded receptacle installed by a licensed electrician. To connect a 120 volt A.C. power cord, always connect the power cord to the switch box on the engine first. Then, plug the other end into the three-hole grounded receptacle. When disconnecting the power cord, always unplug the end from the three-hole grounded receptacle first.**

HOW TO START A COLD ENGINE

1. Fill the fuel tank with a fresh, clean fuel mixture. See "How To Mix The Fuel Mixture".
2. Move the choke control to FULL position.
3. Make sure the **auger drive lever** is in the disengaged (released) position.
4. Insert the **ignition key** and turn to the ON position.
5. Move the **choke control** to the full choke position.
6. **(Electric Start)** Connect the power cord to the **switch box** located on the engine.
7. **(Electric Start)** Plug the other end of the power cord into a three-hole, grounded 120 VOLT, A.C. receptacle. (See the WARNING in this section).
8. Push the **primer button** while covering the vent hole as follows: Remove finger from primer button between primes.

- Do not prime if temperature above 50° F (10° C).
 - Push twice if temperature is 50° F (10° C) to 15°F (-10° C).
 - Push four times if temperature is below 15° F (-10° C).
 - Push five time if temperature is below 0° F (-18° C).
9. **(Electric Start)** Push on the **electric start button** until the engine starts. Do not crank for more than 10 seconds at a time. The electric starter is thermally protected. If the electric starter overheates, it will automatically stop and can only be restarted when it has cooled to a safe temperature. A wait of about 5 to 10 minutes is required to allow the electric starter to cool.
 10. **(Recoil Start)** Rapidly pull the **recoil starter handle**. Do not allow the **recoil starter handle** to snap back. Slowly return the **recoil starter handle**.
 11. If the engine does not start in 5 or 6 tries, See the "Trouble Shooting Chart" Instructions.
 12. **(Electric Start)** When the engine starts, release the **electric start button**.
 13. **(Electric Start)** First disconnect the power cord from the three-hole receptacle. Then, disconnect the power cord from the **switch box**.
 14. As the engine warms up, move the **choke control** to 1/2 choke position. When the engine runs smoothly, move the **choke control** to the off position.

NOTE: Allow the engine to warm up for several minutes before blowing snow in temperatures below 0°F.

WARM START

If restarting a warm engine after a short shutdown, leave choke at "OFF" and do not push the primer button. If the engine fails to start, follow the Cold Start instructions.

 **WARNING: Never run engine indoors or in enclosed, poorly ventilated areas. Engine exhaust contains CARBON MONOXIDE, AN ODORLESS AND DEADLY GAS. Keep hands, feet, hair and loose clothing away from any moving parts on engine and snow thrower.**

The temperature of muffler and nearby areas may exceed 150°F. Avoid these areas.

DO NOT allow children or young teenagers to operate or be near snow thrower while it is operating.

 **WARNING: Do not attempt to remove any item that may become lodged in auger without taking the following precautions:**

- Release auger drive lever.
- Move the ignition lever to the stop position to stop the engine.
- Disconnect spark plug wire.
- Do not place your hands in the auger or discharge chute. Use a pry bar.

OPERATION

SNOW THROWING TIPS

1. When the handle is raised, the auger blades will engage the ground and the snow thrower will move forward. When the auger drive lever is released, the auger blades will stop. If the blades do not stop, see "How To Adjust The Auger Drive Cable" in the Service And Adjustment section.
2. Most efficient snow throwing is accomplished when the snow is removed immediately after it falls.
3. For complete snow removal, slightly overlap each previous path.
4. Whenever possible, discharge the snow down wind.
5. The distance the snow will be discharged can be adjusted by moving the discharge chute deflector. Raise the deflector for more distance or lower the deflector for less distance.
6. In windy conditions, lower the chute deflector to direct the discharged snow close to the ground where it is less likely to blow into unwanted areas.
7. For safety and to prevent damage to the snow thrower, keep the area to be cleared free of stones, toys and other foreign objects.
8. Do not use the auger propelling feature when clearing gravel or crushed rock driveways. Move the handle down to slightly raise the auger.
9. The forward speed of the snow thrower is dependent on the depth and weight of the snow. Experience will establish the most effective method of using the snow thrower under different conditions.
10. After each snow throwing job, allow the engine to run for a few minutes. The snow and accumulated ice will melt off the engine.
11. Clean the snow thrower after each use.
12. Remove ice, snow and debris from the entire snow thrower. Flush with water to remove all salt or other chemicals. Wipe snow thrower dry.

DRY AND AVERAGE SNOW

1. Snow up to eight inches deep can be removed rapidly and easily by walking at a moderate rate. For snow or drifts of a greater depth, slow your pace to allow the discharge chute to dispose of the snow as rapidly as the auger receives the snow.
2. Plan to have the snow discharged in the direction the wind is blowing.

WET PACKED SNOW

Move slowly into wet, packed snow. If the wet, packed snow causes the auger to slow down or the discharge chute begins to clog, back off and begin a series of short back and forth jabs into the snow. These short back and forth jabs, four to six inches, will "belch" the snow from the chute.

SNOW BANKS AND DRIFTS

In snow of greater depth than the unit, use the same "jabbing" technique described above. Turn the discharge chute away from the snow bank. More time will be required to remove snow of this type than level snow.

SERVICE RECOMMENDATIONS

SERVICE RECOMMENDATIONS									
PROCEDURE		FIRST 2 HOUR	BEFORE EACH USE	OFTEN	EVERY 5 HOURS	EVERY 10 HOURS	EVERY 25 HOURS	BEGINNING EACH SEASON	BEFORE STORAGE
S N O W B L O W E R	Tighten all screws and nuts	√		√				√	
	Lubricate Chute Control Flange	√							√
	Check Auger Drive Cable Adjustment (See Cable Adjustment)							√	
	Check Drive Belt								√
E N G I N E	Spark Plug, Check						√	√	
	Fuel, Drain								√

The warranty on this snow blower does not cover items that have been subjected to operator abuse or negligence. To receive full value from the warranty, operator must maintain snow blower as instructed in this manual. The following **Service Recommendations** is supplied to assist operator to properly maintain snow blower. This is a check list only. Adjustment referred to will be found in Adjustments/Repairs section of this manual.

AFTER EACH USE

1. Check for any loose or damaged parts.
2. Tighten any loose fasteners.
3. Check and maintain the auger.
4. After each use, remove all snow and slush off the snow blower to prevent freezing of auger or controls.
5. Check controls to make sure they are functioning properly.
6. If any parts are worn or damaged, replace immediately.

LUBRICATION

Before Storage

1. Remove the **top cover**. See "How To Remove The Top Cover".
2. Lubricate the **chute control flange**. Apply a clinging type of grease such as Lubriplate.

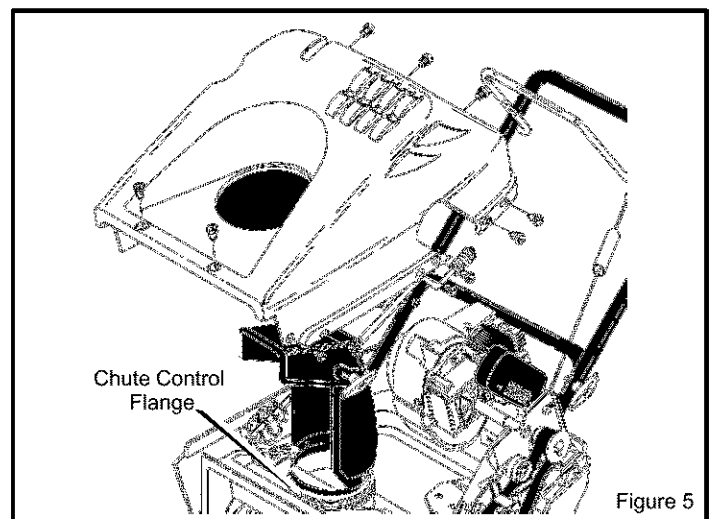
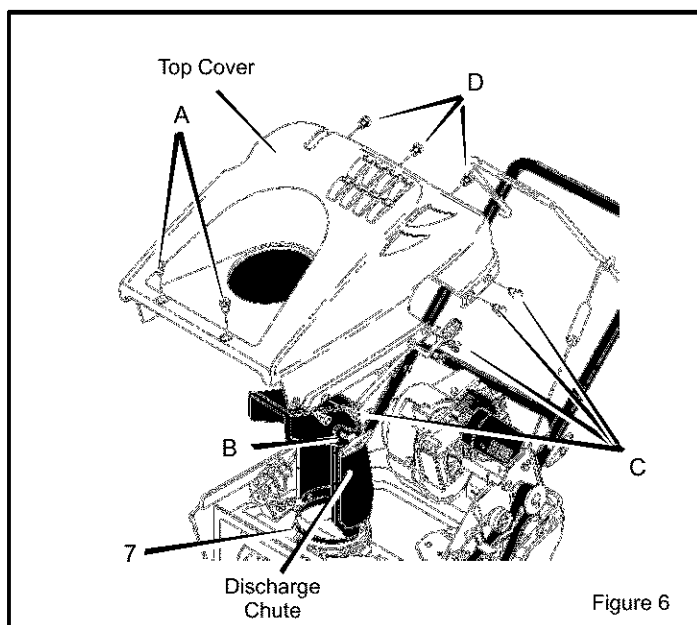

Figure 5

CUSTOMER RESPONSIBILITIES

HOW TO REMOVE THE TOP COVER

1. Remove the **discharge chute**.
2. Remove the fuel cap.
3. Remove the two **bolts and nuts (A)** from the front of the **top cover**.
4. Remove the two **bolts (B)** from the left and right side of the **top cover**.
5. Remove the eight **screws (C)** on the left and right side of the **top cover**.
6. Remove the three **screws (D)** from the top portion of the control panel.
7. Carefully pull the rear of the **top cover** up and over the gas tank.
8. To install the **top cover**, reverse the above steps.



HOW TO REMOVE THE BELT COVER

1. If equipped, remove the **heat shield** from the rear of the **belt cover**.
2. Remove the **bolts and nuts (A)** that hold the **belt cover** to the auger housing.
3. If the top cover has not been removed, then remove the **screws (B)** that attach the **belt cover** to the **top cover**.
4. Remove **screw (C)** that holds the **belt cover** to the **bottom cover**.
5. To remove, hold the bottom portion of the **belt cover** and pull down and out.
6. To install the **belt cover**, reverse the above steps.

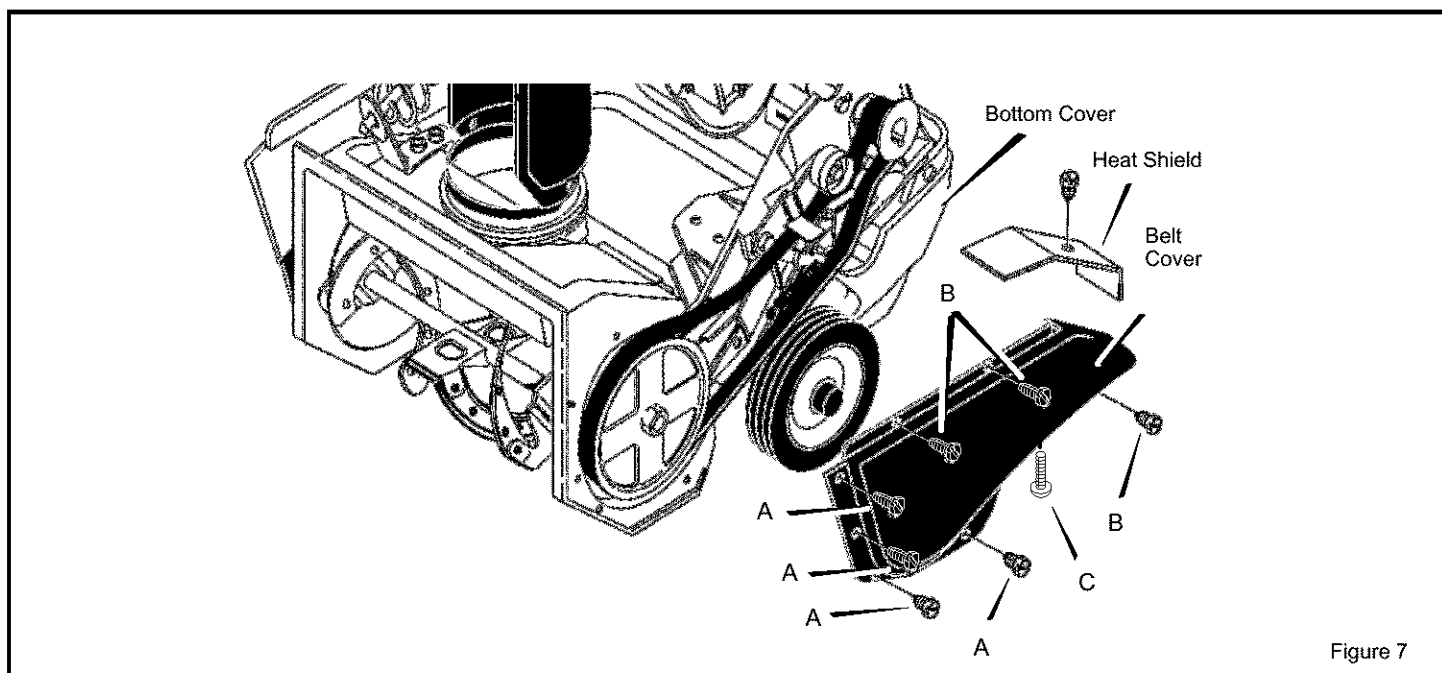

ADJUSTMENT/REPAIR



WARNING: To prevent accidental starting when making any adjustments or repairs, always disconnect the spark plug wire and place it where it cannot make contact with the spark plug.

HOW TO ADJUST THE CHUTE CRANK

If the chute crank will not rotate fully to the left or right, adjust as follows.

1. Remove the top cover. See "How To Remove The Top Cover".
2. Loosen the nuts.
3. Move the **crank adjusting bracket** to allow **1/8 inch (3mm) clearance** between the notch in the **flange** and the outer diameter of the **worm gear**.
4. Tighten the nuts.

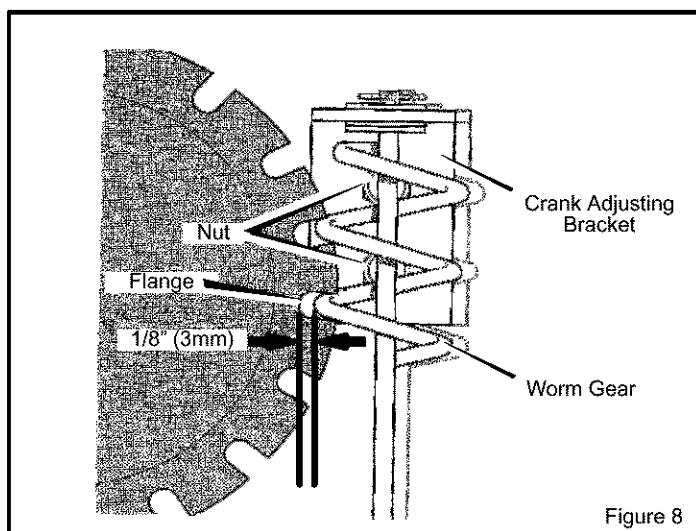

Figure 8

HOW TO ADJUST THE AUGER CONTROL CABLE

The auger control cable is adjusted at the factory. During normal use, the auger control cable can become stretched and the auger drive lever will not properly engage or disengage the auger.

1. Remove the "Z" hook from the **auger drive lever** (Figure 9).
2. Slide the **cable boot** off the **cable adjustment bracket** (Figure 10).
3. Push the bottom of the **auger control cable** through the **cable adjustment bracket** until the "Z" hook can be removed.
4. Remove the "Z" hook from the **cable adjustment bracket**. Move the "Z" hook down to the next adjustment hole.
5. Pull the **auger control cable** up through the **cable adjustment bracket**.
6. Put the **cable boot** over the **cable adjustment bracket**.
7. Install the "Z" hook to the **auger drive lever**.
8. To check the adjustment, start the snow thrower. Make sure the auger does not rotate when the auger drive lever is released.

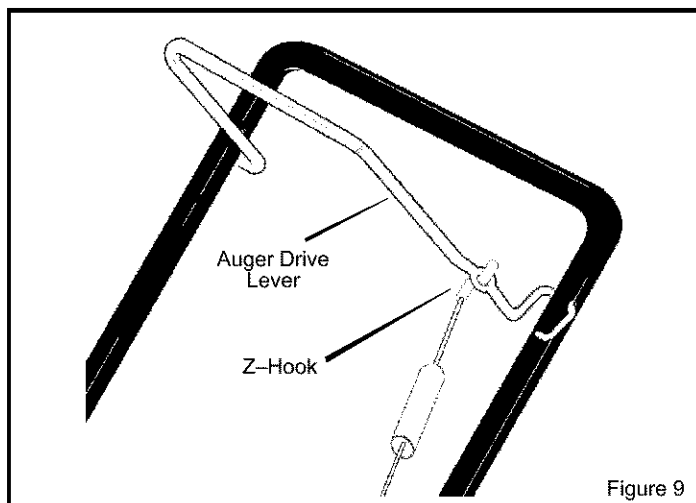

Figure 9

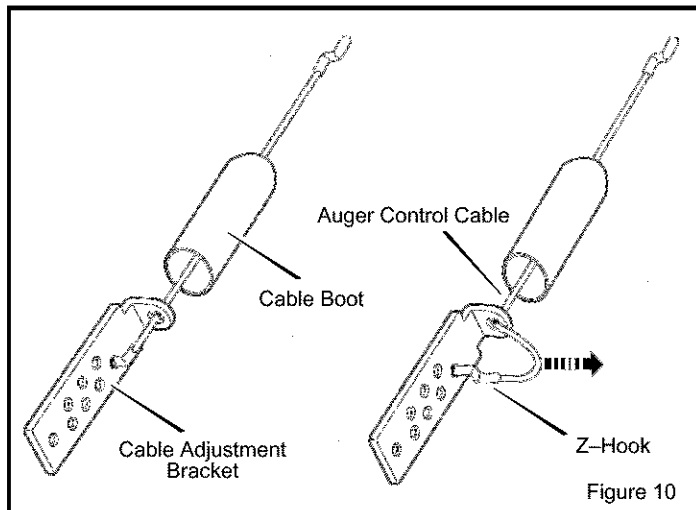

Figure 10

ADJUSTMENT/REPAIR

HOW TO SET THE DRIVE BELT TENSION

The tension of the drive is set at the factory. If the distance of the discharged snow decreases, then set the drive belt tension as follows:

1. Disconnect the wire from the spark plug.
2. Remove the belt cover. See "How To Remove The Belt Cover".
3. Loosen, do not remove, the **nut** on the **idler pulley**. (See Figure 11).
4. Move the **idler pulley** to the bottom of the slot in the idler arm.
5. Tighten the **nut** on the **idler pulley**.
6. Connect the wire to the spark plug.

NOTE: If the idler pulley is already in the bottom position, replace the belt.

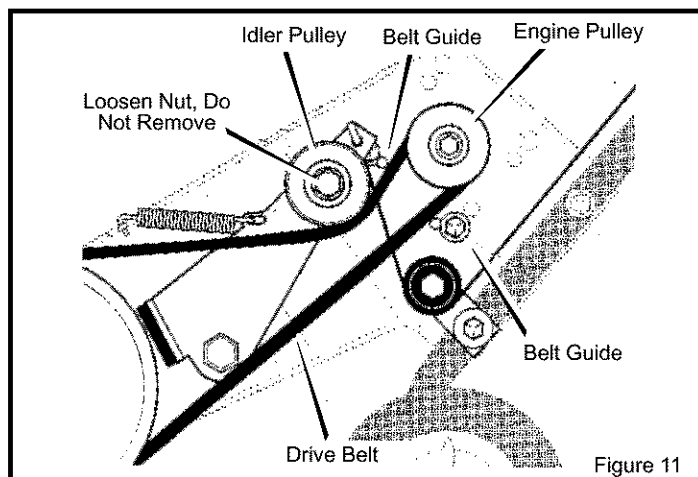

HOW TO REPLACE THE DRIVE BELT

The drive belt is of special construction and must be replaced with original factory replacement belt available from your nearest Sears authorized service center.

1. Remove the belt cover. See "How To Remove The Belt Cover".
2. Remove the **drive belt** from the **idler pulley** (Figure 12).
3. Remove the **drive belt** from the **engine pulley**. Be careful. Do not bend the belt guides.
4. Remove the **drive belt** from the **auger pulley**.

5. To install the new **drive belt**, reverse the above steps.
6. Make sure the **drive belt** is seated properly on the pulleys.
7. Set the belt guide to $3/32$ " clearance as shown in Figure 13.

NOTE: When the auger control lever is engaged, the belt guide must be $3/32$ " from the drive belt.

8. Install belt cover. See "How To Remove The Belt Cover".

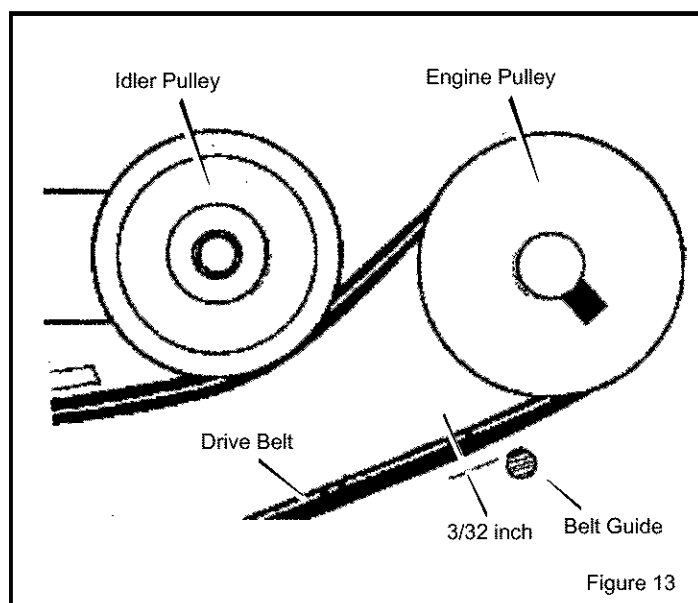
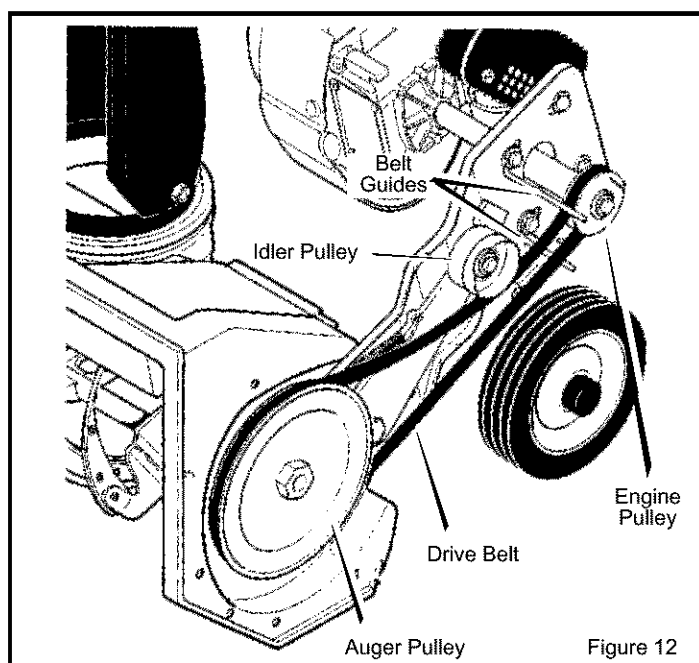

ADJUSTMENT/REPAIR

HOW TO REPLACE THE AUGER

1. Remove the belt cover. See "How To Remove The Belt Cover".
2. Remove the drive belt. See "How To Replace The Drive Belt".
3. Remove the **auger pulley** from the auger shaft (threads are left hand; turn clockwise to remove). (See Figure 14).
4. To keep the auger from rotating, set a 2"x4" piece of wood on the center paddle to secure auger.
5. Remove the fasteners from the **bearing assembly**. Remove the **bearing assembly** from the **auger housing**.
6. Slide the **auger** out of the bearing assembly on the right side of the snow thrower.
7. Tip the **auger** enough to allow the **auger** to slide out of the **auger housing**.
8. To install **auger**, reverse the above steps.

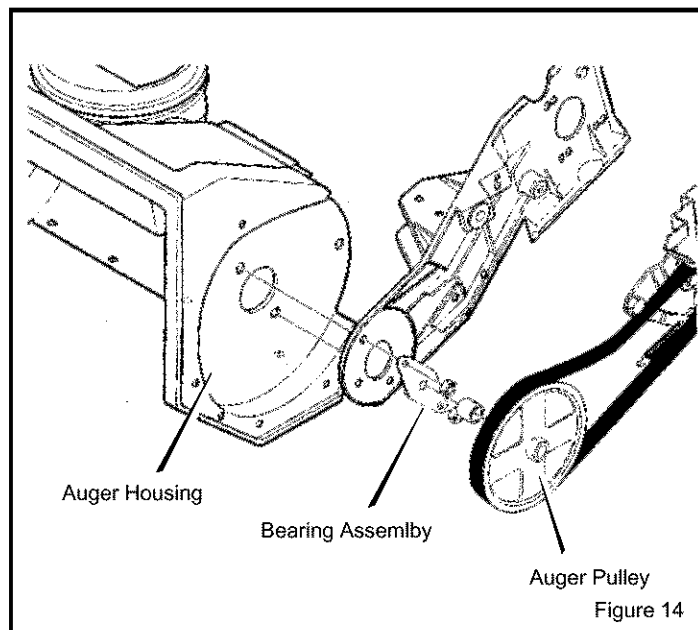

ADJUSTMENT/REPAIR

TO ADJUST THE CARBURETOR

The carburetor is not adjustable. Engine performance should not be affected at altitudes up to 7,000 feet. For operation at higher elevations, contact your nearest Sears Store.

IMPORTANT: Never tamper with the engine governor, which is factory set for proper engine speed. Over-speeding the engine above the factory high speed setting can be dangerous. If the engine-governed high speed needs an adjustment, contact an authorized Sears Service Center. They have the proper equipment and experience to make any necessary adjustments.

TO ADJUST OR REPLACE THE SPARK PLUG

Check the **spark plug** every twenty-five (25) hours. Replace the **spark plug** if the electrodes are pitted or burned or if the porcelain is cracked.

The spark plug is housed in the engine compartment under the top cover and cannot be seen under normal conditions.

1. Open the spark plug **access door** on the control panel (Figure 15).
2. The spark plug and wire are now visible.
3. Remove the spark plug wire.
4. Clean the area around the spark plug base to prevent dirt from entering the engine when the spark plug is removed.
5. Remove the spark plug.
6. Check the spark plug. If the spark plug is cracked, fouled or dirty, it must be replaced .
7. Set the gap between the electrodes of the new spark plug at 0.030 inch (Figure 16).
8. Install the spark plug in the cylinder head and firmly tighten. Recommended torque is 18 to 20 foot pounds.

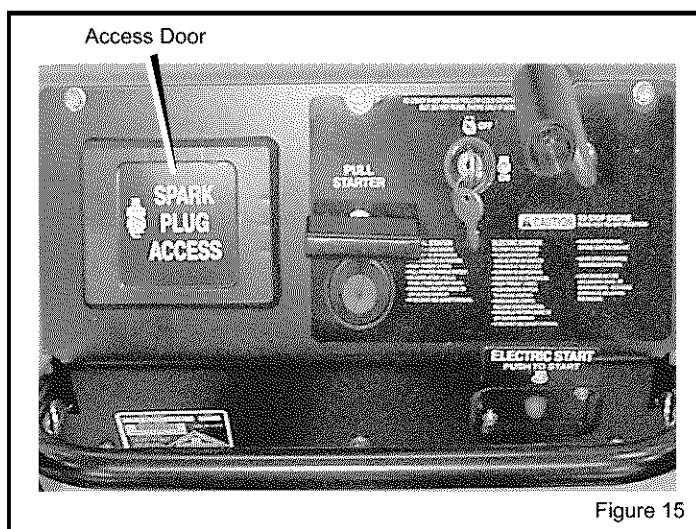

Figure 15

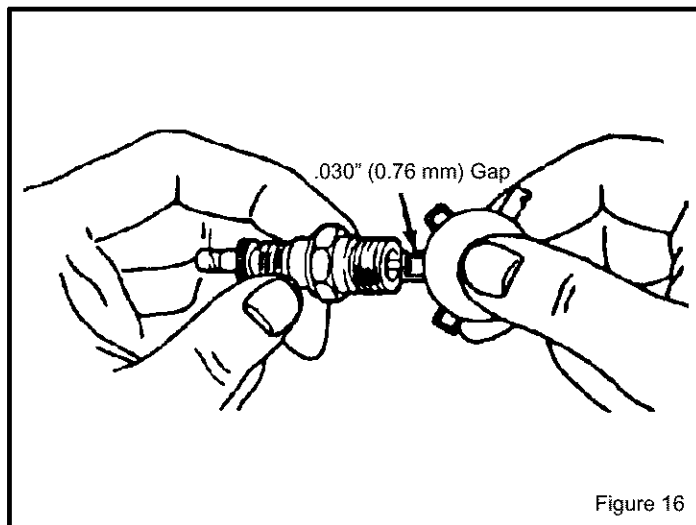

Figure 16

STORAGE

OFF SEASON STORAGE



WARNING: Never store the engine, with fuel in the tank, indoors or in a poor ventilated enclosure where fuel fumes could reach an open flame, spark or pilot light as on a furnace, water heater, clothes dryer, etc.

Handle gasoline carefully. It is highly flammable and careless use could result in serious fire damage to your person and /or property.

Drain fuel into approved containers outdoors, away from open flame.

If the snow blower is to be stored for thirty (30) days or more at the end of the snow season, the following steps are recommended to prepare your snow blower for storage.

NOTE: Gasoline must be removed or treated to prevent gum deposits from forming in the tank, filter, hose, and carburetor during storage.

1. To remove gasoline, run engine until tank is empty and engine stops. Then drain remaining gasoline from carburetor by pressing upward on bowl drain located on the bottom of carburetor (see Figure 17).



WARNING: Drain gasoline outdoors, away from fire or flame.

If you do not want to remove gasoline use the fuel stabilizer supplied with unit. Add fuel stabilizer to any gasoline left in the tank to minimize gum deposits and acids. If the tank is almost empty, mix stabilizer with fresh gasoline in a separate container and add some to the tank. ALWAYS FOLLOW INSTRUCTIONS ON STABILIZER CONTAINER. THEN RUN ENGINE AT LEAST 10 MINUTES AFTER STABILIZER IS ADDED TO ALLOW MIXTURE TO REACH CARBURETOR. STORE SNOW BLOWER IN SAFE PLACE.

2. You can help keep your engine in good operating condition by changing oil before storage.

3. Lubricating the piston/cylinder area. This can be done by first removing the spark plug and squirting clean engine oil into the spark plug hole. Then cover the spark plug hole with a rag to absorb oil spray. Next, rotate the engine by pulling the starter two or three times. Finally, reinstall spark plug and attach spark plug wire.
4. Thoroughly clean the snow blower.
5. Lubricate all lubrication points (see Lubrication, see Customer Responsibilities).
6. Insure that all nuts, bolts, and screws are securely fastened. Inspect all visible moving parts for damage, breakage, and wear. Replace if necessary.
7. Touch up all rusted or chipped paint surfaces; sand lightly before painting.
8. Cover the bare metal parts of the blower housing auger, and the impeller with rust preventative.
9. If possible, store your snow blower indoors and cover it to give protection from dust and dirt.
10. If the machine must be stored outdoors, block up the snow blower and insure the entire machine is off the ground. Cover the snow blower with a heavy tarpaulin.

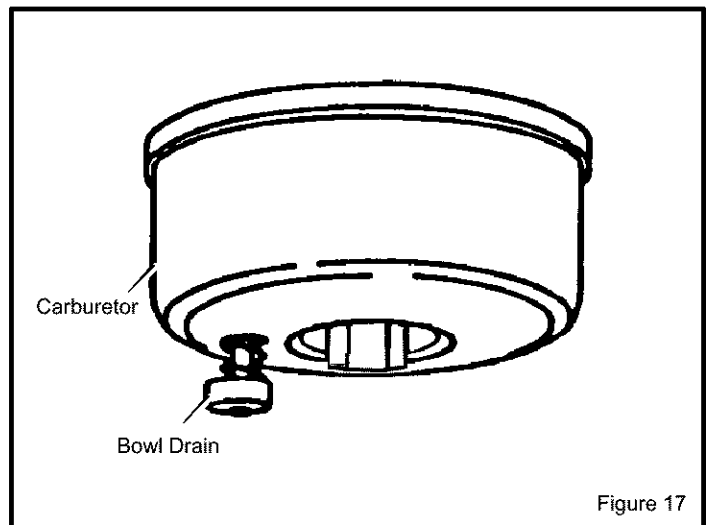

Figure 17

TROUBLE SHOOTING CHART

PROBLEM	LOOK FOR	REMEDY
Difficult starting	Defective spark plug.	Replace defective spark plug.
Engine runs erratically	Blocked fuel line.	Clean fuel line.
	Empty gas tank.	Check fuel supply,
	Stale gasoline.	Add fresh gasoline.
	Water or dirt in fuel system.	Remove carburetor bowl to drain fuel tank. Refill with fresh fuel. CAUTION: Do not remove carburetor bowl when the engine is hot.
Engine stalls	Unit running on CHOKE.	Set choke lever to RUN position.
Loss of power	Gas cap vent hole is plugged.	Remove ice and snow from cap. Be sure vent hole is clear.
Excessive vibration	Loose parts or damaged impeller.	Stop engine immediately and remove spark plug wire. Tighten all bolts and make all necessary repairs. If vibration continues, have the unit serviced by a competent repairman.
Unit fails to propel itself	Drive belt loose or damaged.	Replace drive belt. Refer to Drive Belt Replacement in Adjustments/Repairs section of this manual.
	Incorrect adjustment of traction drive cable.	Adjust traction drive cable. Refer to Cable Adjustment in Adjustments/Repairs section of this manual.
Unit fails to discharge snow	Auger drive belt loose or damaged.	Replace or adjust auger drive belt. Refer to Drive Belt Replacement and Drive Belt Adjustment in Adjustments/Repairs section of this manual.
	Auger control cable not adjusted correctly.	Adjust auger control cable. Refer to Cable Adjustment in Adjustments/Repairs section of this manual.
	Discharge chute clogged.	Stop engine immediately and disconnect spark plug wire. Refer to the first Warning in Snow blower Operation in Operation section of this manual. Clean discharge chute and inside of auger housing.
	Foreign object lodged in auger.	Stop engine immediately and disconnect spark plug wire. Remove object from auger housing.

Identifying Your Snowthrower

Your new Snow blower has two (2) identifying numbers: (1) unit model number: (2) unit serial number. The two preceding numbers are required to insure that the proper replacement parts are obtained when required. If you have any questions concerning parts, service, or technical data, contact your nearest Sears Service Department.

For complete warranty information refer to the warranty in the Owner's Information section of this manual.

CRAFTSMAN 21" SNOW BLOWER C950-52935-1
CRAFTSMAN 21" CHASSE-NEIGE C950-52935-1

REPAIR PARTS
PIÈCES DE RECHANGE
ENGINE / MOTEUR

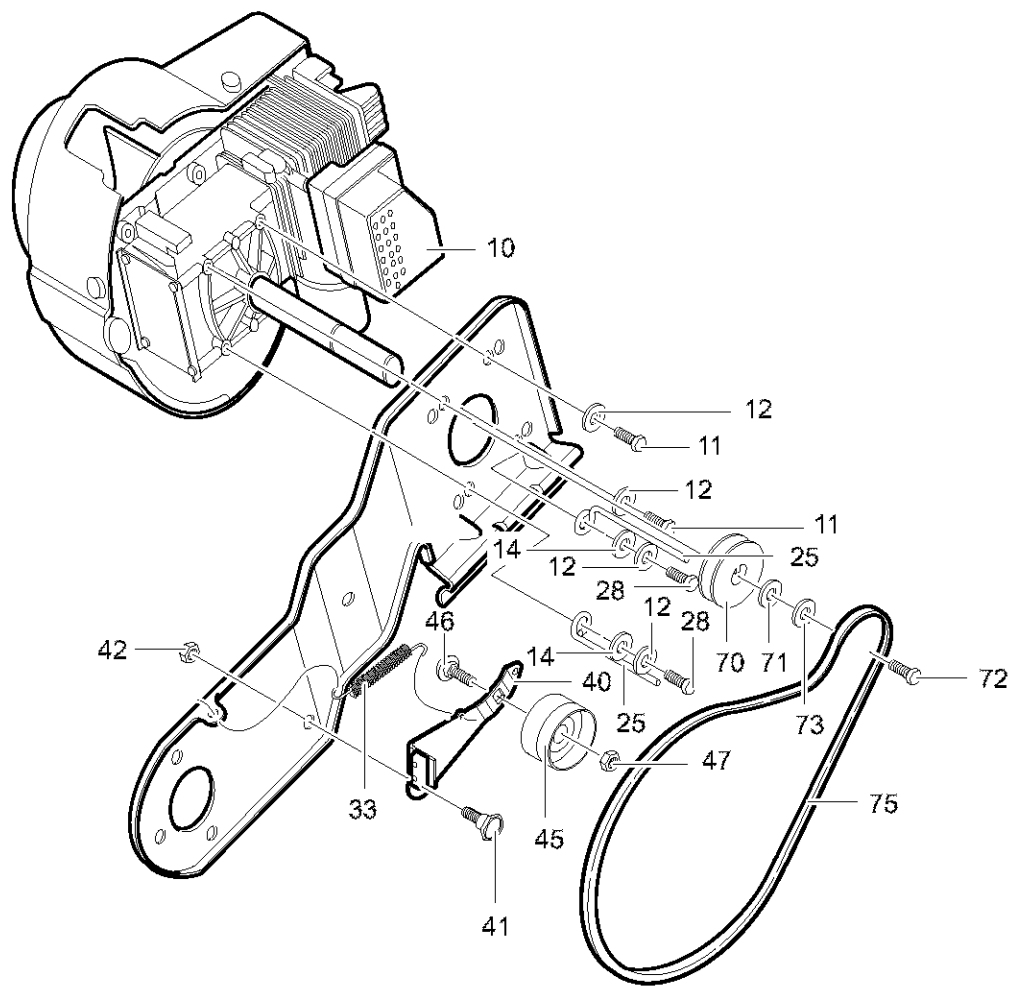

342481

Key No. N° sur le schéma	Description	Description	Part No. N° de pièce
10	(SEE ENGINE MANUAL)	(VOIR MANUEL DU MOTEUR)	ENGINE
11	SCREW, 5/16-18 X.75	VIS, 5/16-18 X0,75	180077
12	WASHER	RONDELLE	120838
14	FLATWASHER	RONDELLE PLATE	71071
25	BELT GUIDE	GUIDE DE COURROIE	313440
28	SCREW, 5/16-18X1.00	VIS, 5/16-18X1,00	710312
33	SPRING, IDLER BRAKE	RESSORT, FREIN DE POULIE	165x146
40	IDLER ARM	BRAS DE POULIE DE TENSION	1501013
41	BOLT	BOULON	333594
42	NUT	ÉCROU	71391
45	PULLEY, IDLER	POULIE DE TENSION	48924
46	BOLT	BOULON	45892
47	NUT	ÉCROU	590
70	PULLEY	POULIE	338849
71	WASHER	RONDELLE	25840
72	SCREW, 5/16-24X.75	VIS, 5/16-24X0,75	181595
73	WASHER	RONDELLE	120838
75	BELT	COURROIE	760928
—	BOOK, INSTRUCTION	LIVRE, INSTRUCTIONS	F-001155M

CRAFTSMAN 21" SNOW BLOWER C950-52935-1
CRAFTSMAN 21" CHASSE-NEIGE C950-52935-1

REPAIR PARTS
PIÈCES DE RECHANGE
FRAME COMPONENTS / BÂTI

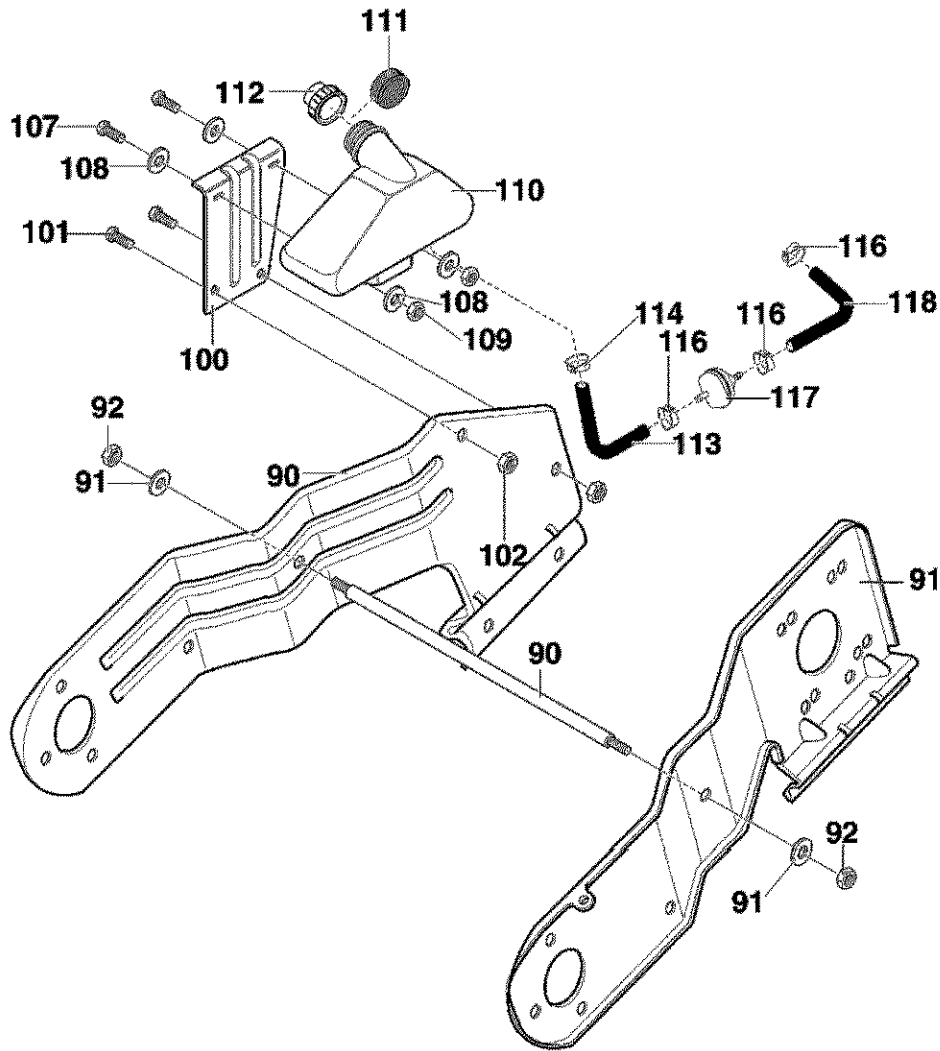

342434

Key No.
N° sur le
schéma

Description

80	FRAME, RIGHT
81	FRAME, LEFT
90	ROD, SUPPORT
91	WASHER
92	NUT, 3/8-16
100	BRACKET, GAS TANK
101	SCREW, 1/4-20X.75
102	NUT, 1/4-20
107	SCREW, 1/4-20X.75
108	WASHER, FLAT
109	NUT, 1/420
110	TANK, FUEL
111	RING, FUEL TANK
112	CAP, GAS
113	TUBING, 8 IN.
114	CLAMP, HOSE SCREW
116	CLAMP, HOSE
117	FILTER IN LINE
118	TUBING, 6 IN.

Description

BÂTI DROIT
BÂTI GAUCHE
TRINGLE DE SUPPORT
RONDELLE
ÉCROU, 3/8-16
SUPPORT, RÉSERVOIR ESSENCE
VIS, 1/4-20X0,75
ÉCROU, 1/4-20
VIS, 1/4-20X0,75
RONDELLE PLATE
ÉCROU, 1/4-20
RÉSERVOIR ESSENCE
JOINT, RÉSERVOIR ESSENCE
BOUCHON DU RÉSERVOIR
TUBE, 8 PO.
PINCE, VIS DU TUBE
PINCE, TUBE
FILTRE DE TUBE
TUBE, 6 PO.

Part No.
N° de pièce

760272-853
760271-853
760168
71083
71044
333749-853
180020
782585
302628
71087
73826
333739
762224
340300
323363
47345
323387
56679
335906



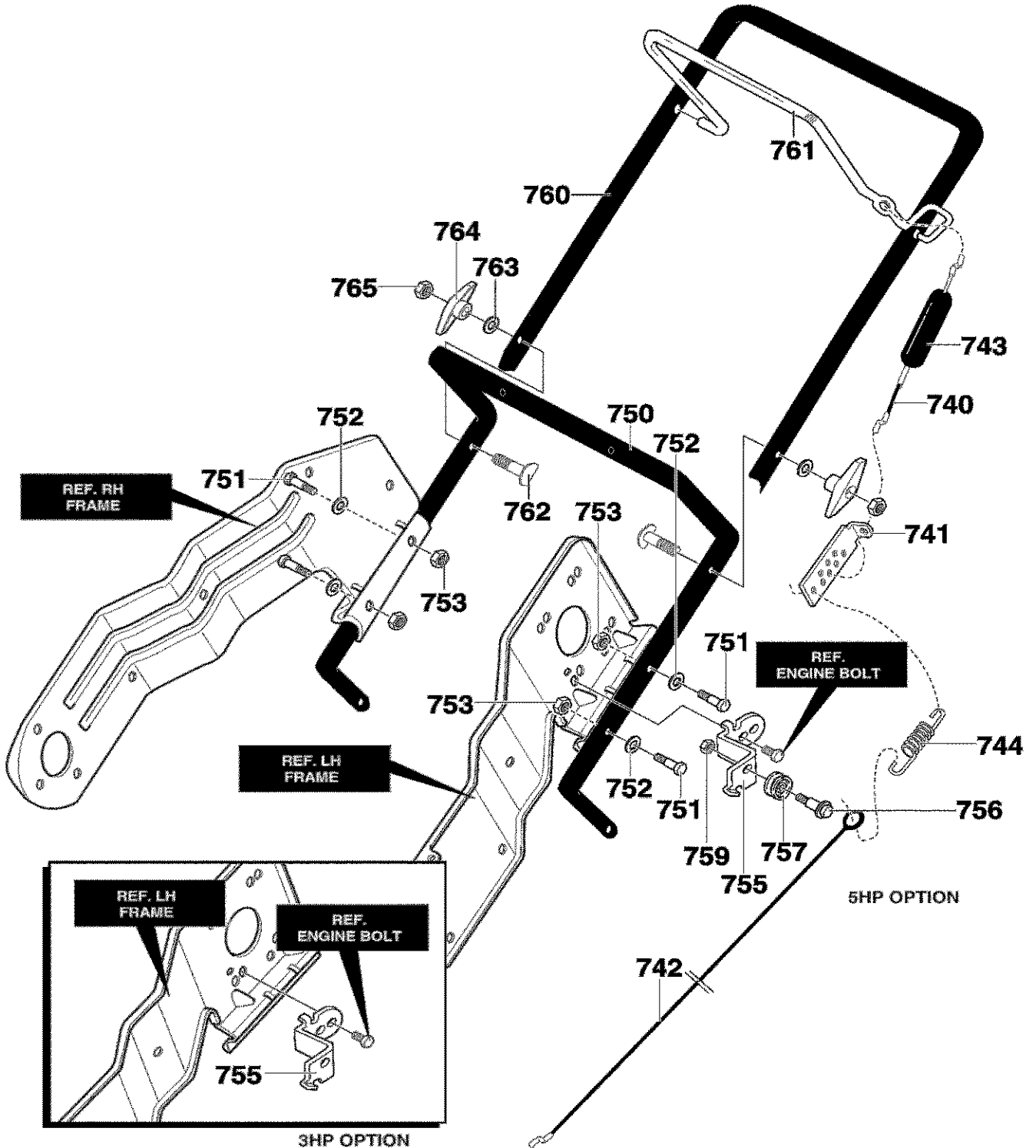

342436



CRAFTSMAN 21" SNOW BLOWER C950-52935-1
CRAFTSMAN 21" CHASSE-NEIGE C950-52935-1

REPAIR PARTS
PIÈCES DE RECHANGE
HANDLE / POIGNÉE

Key No. N° sur le schéma	Description	Description	Part No. N° de pièce
740	CABLE, UPPER	CÂBLE SUPÉRIEUR	760774
741	BRACKET, CABLE ADJ	SUPPORT, RÉGLAGE DU CÂBLE	313441
742	CABLE LOWER CONTROL	CÂBLE, CONTRÔLE NIVEAU INFÉRIEUR	760773
743	BOOT, CLUTCH SPRING	CAPUCHON, RESSORT D'EMBRAYAGE	308146
744	SPRING	RESSORT	165x146
750	HANDLE LOWER	PARTIE INFÉRIEURE DU GUIDON	333909-853
751	SCREW, 1/4-20X1.25	VIS, 1/4-20X1.25	313674
752	WASHER, FLAT	RONDELLE PLATE	71067
753	NUT, 1/4-20	ÉCROU, 1/4-20	782585
755	BRACKET, CABLE	ATTACHE-CÂBLE	761486-853
756	BOLT	BOULON	712234
757	PULLEY	POULIE	39298
759	NUT, 1/4-20	ÉCROU, 1/4-20	782585
760	HANDLE, UPPER	PARTIE SUPÉRIEURE DU GUIDON	333919-853
761	BAIL, CONTROL	MANCHE DE CONTRÔLE	333954-853
762	BOLT, 5/16-18X2.00	BOULON, 5/16-18X2,00	337584
763	WASHER, FORM	RONDELLE, FORM	311936
764	KNOB,T	POIGNÉE EN T	57171
765	NUT, 5/16-18	ÉCROU, 5/16-18	71037



CRAFTSMAN 21" SNOW BLOWER C950-52935-1
CRAFTSMAN 21" CHASSE-NEIGE C950-52935-1

REPAIR PARTS
PIÈCES DE RECHANGE
AUGER HOUSING / VIS SANS FIN

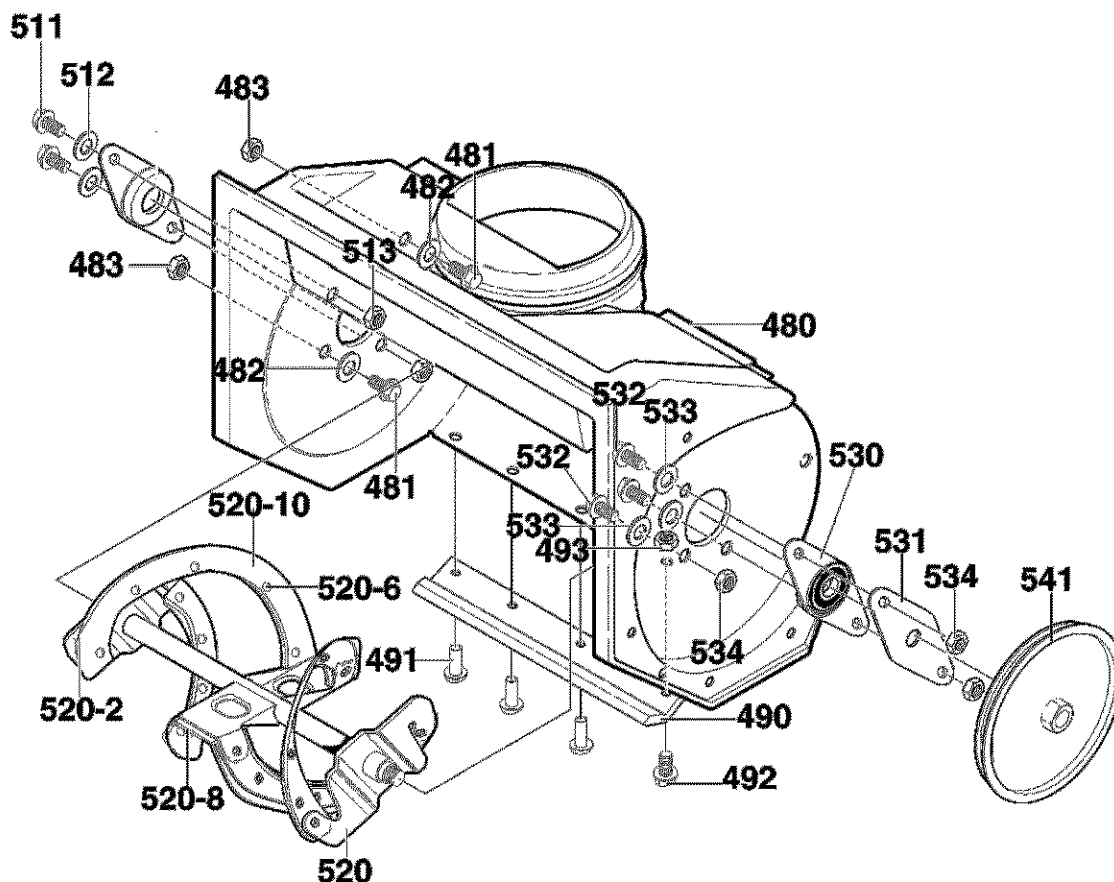

342439

Key No.
N° sur le
schéma

Key No. N° sur le schéma	Description
480	HOUSING, ASSY
481	SCREW, 1/4-20X.75
482	WASHER
483	NUT, 1/4-20
490	BLADE, SCRAPER
491	RIVET
492	SCREW, 1/4-20X.75
493	NUT, 1/4-20
510	BEARING, FLANGE
511	SCREW, 1/4-20X1.00
512	WASHER, FLAT
513	NUT, 1/4-20
520	AUGER, ASSY
520-2	BLADE, AUGER
520-6	RIVET
520-8	BLADE, CENTER
520-10	AUGER & BLADE SUPPORT
530	BEARING & PLATE ASSEMBLY
531	PLATE, RETAINER
532	SCREW, 1/4-20X.63
533	WASHER, FLAT
534	NUT, 1/4-20 REGHEXCTRLK
541	PULLEY, V3L 6.00

Description

Description	Part No. N° de pièce
CARTER	340091
VIS, 1/4-20X0.75	302628
RONDELLE	71067
ÉCROU, 1/4-20	73826
LAME, RACLEUR	55323
RIVET	577707
VIS, 1/4-20X0.75	302628
ÉCROU, 1/4-20	302635
PALIER À BRIDE	577023
VIS, 1/4-20X1.00	710263
RONDELLE PLATE	71067
ÉCROU, 1/4-20	302635
VIS SANS FIN	327072
LAME DE FRAISE	302565
RIVET	49838
LAME CENTRALE	335992
VIS SANS FIN & SUPPORT DE LAME	307049
ROULEMENT ET PLAQUE	583459
PLAQUE DE FIXATION	334287
VIS, 1/4-20X0.63	579052
RONDELLE PLATE	71067
ÉCROU, 1/4-20 REGHEXCTRLK	73826
POULIE, V3L 6.00	338965

CRAFTSMAN 21" SNOW BLOWER C950-52935-1
CRAFTSMAN 21" CHASSE-NEIGE C950-52935-1

REPAIR PARTS
PIÈCES DE RECHANGE

DISCHARGE CHUTE / DÉFLECTEUR DE GOULOTTE

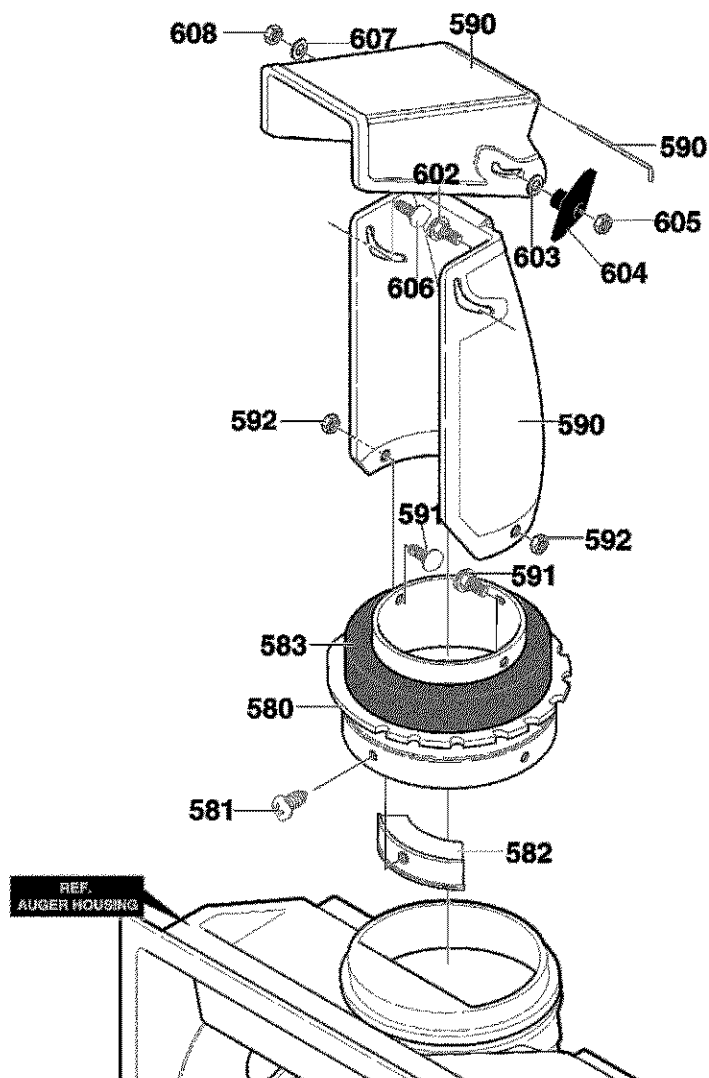

337341

Key No. N° sur le schéma	Description	Description	Part No. N° de pièce
580	RING, CHUTE	SEGMENT, DÉFLECTEUR	333859
581	SCREW, #10X.50	VIS, #10X0,50	711752
582	GUIDE, CHUTE	GUIDE DE DÉFLECTEUR	577021
583	DONUT FOAM	RONDELLE MOUSSE	762173
590	CHUTE ASSY.	DÉFLECTEUR	762222
591	SCREW 1/4-20X.50	VIS, 1/4-20X0,50	313686
592	NUT, 1/4-20	ÉCROU, 1/4-20	302635
602	BOLT, 5/16-18X1.25	BOULON, 5/16-18X1,25	302843
603	WASHER, FLAT	RONDELLE PLATE	71071
604	KNOB, T	POIGNÉE EN T	57171
605	NUT, 5/16-18	ÉCROU, 5/16-18	71037
606	SCREW, 5/16-18X.75	VIS, 5/16-18X0,75	578088
607	WASHER, FLAT	RONDELLE PLATE	71071
608	NUT, 5/16-18	ÉCROU, 5/16-18	71391

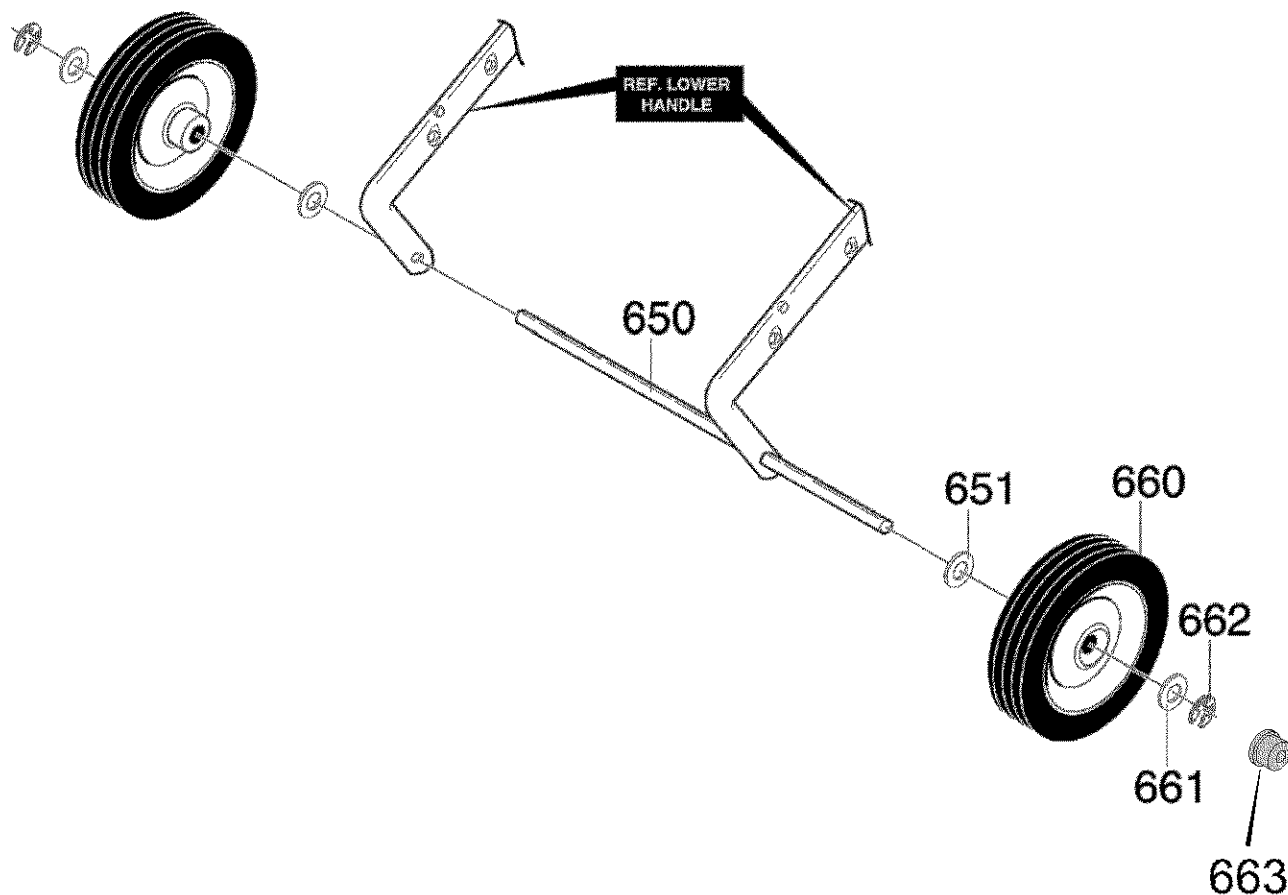

335418

Key No. N° sur le schéma	Description	Description	Part No. N° de pièce
650	AXLE SHAFT	ESSIEU	313678
651	WASHER, FLAT	RONDELLE PLATE	583409
660	TIRE & RIM	PNEU ET JANTE	760713
661	WASHER, FLAT	RONDELLE PLATE	583409
662	RING, RET E	RONDELLE DE FIXATION EN E	577598
663	CAP, HUB	ENJOLIVEUR DE MOYEU	577037

CRAFTSMAN 21" SNOW BLOWER C950-52935-1
CRAFTSMAN 21" CHASSE-NEIGE C950-52935-1

REPAIR PARTS
PIÈCES DE RECHANGE
ELECTRIC STARTER / ELECTRIQUE

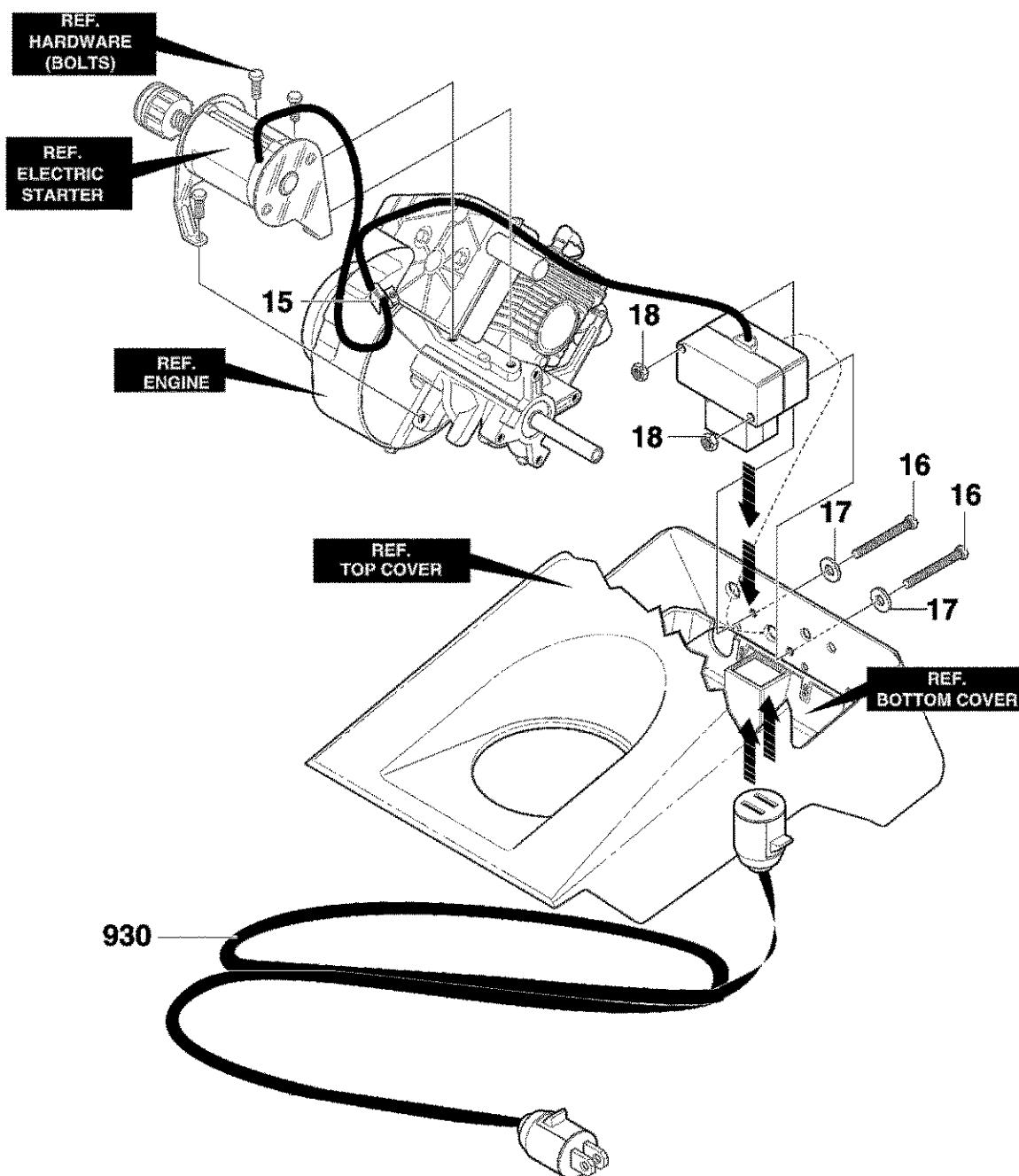

313974

Key No. N° sur le schéma	Description	Description	Part No. N° de pièce
15	RETAINER	FIXATION	57569
16	SCREW	VIS	311633
17	WASHER, FLAT	RONDELLE PLATE	414106
18	NUT	ÉCROU	271163
930	CORD EXTENSION	RALLONGE	56023
		27	

CRAFTSMAN 21" SNOW BLOWER C950-52935-1
CRAFTSMAN 21" CHASSE-NEIGE C950-52935-1

REPAIR PARTS
PIÈCES DE RECHANGE
CHUTE ROD / GOULOTTE TIGE

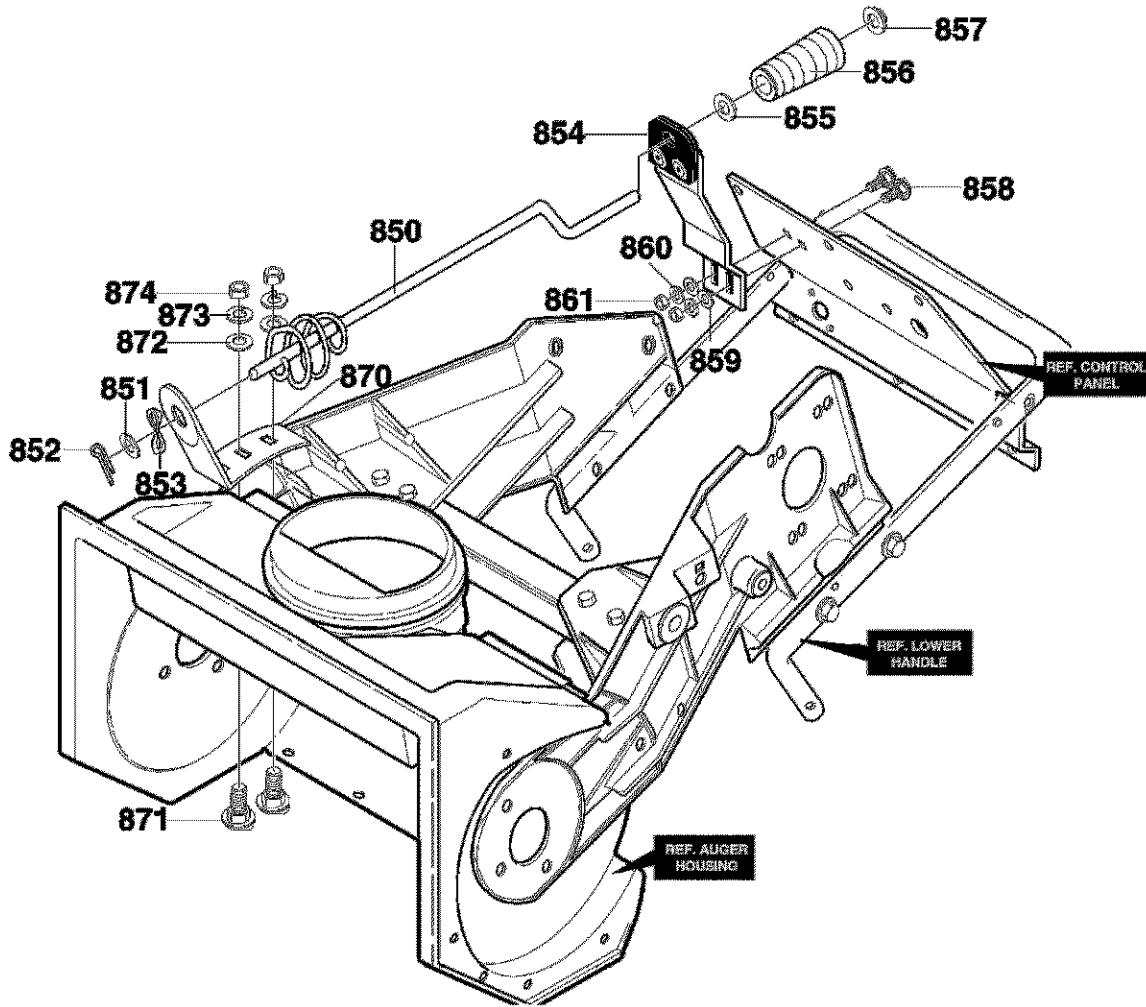

334313

Key No.
N° sur le
schéma

Description

Description

Part No.
N° de pièce

850	ROD, CHUTE	TIGE DU DÉFLECTEUR	337941
851	WASHER, FLAT	RONDELLE PLATE	71072
852	PIN, COTTER	GOUILLE FENDUE	71082
853	WASHER CURVED	RONDELLE COURBÉE	313431
854	ASSEMBLY, CHUTE CRANK	MANIVELLE DU DÉFLECTEUR	335264
855	WASHER, FLAT	RONDELLE PLATE	71072
856	KNOB, SLEEVE	POIGNÉE	57082
857	NUT, PUSH	ÉCROU RAPIDE	331532
858	BOLT, 1/4-20X.63	BOULON, 1/4-20X0,63	3809
859	WASHER, FLAT	RONDELLE PLATE	120393
860	WASHER	RONDELLE	71060
861	NUT, 1/4-20	ÉCROU, 1/4-20	71034
870	BRACKET, CHUTE	SUPPORT DU DÉFLECTEUR	333946-853
871	BOLT, 5/16-18X.75	BOULON, 5/16-18X0,75	340720
872	WASHER, FLAT	RONDELLE PLATE	71071
873	WASHER	RONDELLE	71060
874	NUT, 5/16-18	ÉCROU, 5/16-18	71037
		28	

CRAFTSMAN 21" SNOW BLOWER C950-52935-1
CRAFTSMAN 21" CHASSE-NEIGE C950-52935-1

REPAIR PARTS
PIÈCES DE RECHANGE

TOP COVER ASSEMBLY / CARTER SUPÉRIEUR

Key No. N° sur le schéma	Description	Description	Part No. N° de pièce
120	COVER, BOTTOM	CARTER VENTRAL	340097
121	SCREW, 1/4-14X .75	VIS, 1/4-14X 0,75	313685
122	PANEL, ACCESS	PANNEAU, ACCÈS	761538
124	NUT, 1/4-10 SPEED	ÉCROU, 1/4-10 SPEED	578109
125	PANEL, CONTROL	PANNEAU DE COMMANDES	761539-853
126	SCREW, 1/4-20X1.25	VIS, 1/4-20X1.25	313674
127	WASHER, FLAT	RONDELLE PLATE	71067
128	NUT, 1/4-20	ÉCROU, 1/4-20	762585
130	GROMMET	OEILLET	57587
131	KNOB	POIGNÉE	333643
140	SWITCH, IGNITION	CONTACT DU DÉMARREUR	56992
141	WASHER	RONDELLE	313683
142	NUT, 5/8-32	ÉCROU, 5/8-32	300193
143	2 KEYS & RING	2 CLÉS & PORTE-CLÉ	49643
145	PRIMER BULB	BOUTON D'AMORÇAGE	54601
146	HOSE, PRIMER	TUYAU DE L'AMORCEUR	335507
147	NUT, 1/4-20	ÉCROU, 1/4-20	271172
150	COVER, BELT	CARTER DE COURROIE	340089
151	SCREW, 10-24X .50	VIS, 10-24X 0,50	12342
152	NUT, #10-24	ÉCROU, #10-24	312300
157	SCREW, 1/4-14X .75	VIS, 1/4-14X 0,75	313685
159	NUT, 1/4-10 SPEED	ÉCROU, 1/4-10 SPEED	578109
170	COVER, TOP	CARTER SUPÉRIEUR	340098
171	SCREW, 10-24X .50	VIS, 10-24X 0,50	12342
172	NUT, #10-24	ÉCROU, #10-24	312300
173	SCREW, 1/4-14X .75	VIS, 1/4-14X 0,75	313685
176	NUT, 1/4-10 SPEED	ÉCROU, 1/4-10 SPEED	578109
181	SCREW, 1/4-14X .75	VIS, 1/4-14X 0,75	313685
182	NUT, 1/4-10 SPEED	ÉCROU, 1/4-10 SPEED	578109



TECUMSEH 5 HP 2 CYCLE ENGINE HSK850-8330C

REPAIR PARTS

MOTEUR 5 HP 2 TEMPS TECUMSEH HSK850-8330C PIÈCES DE RECHANGE

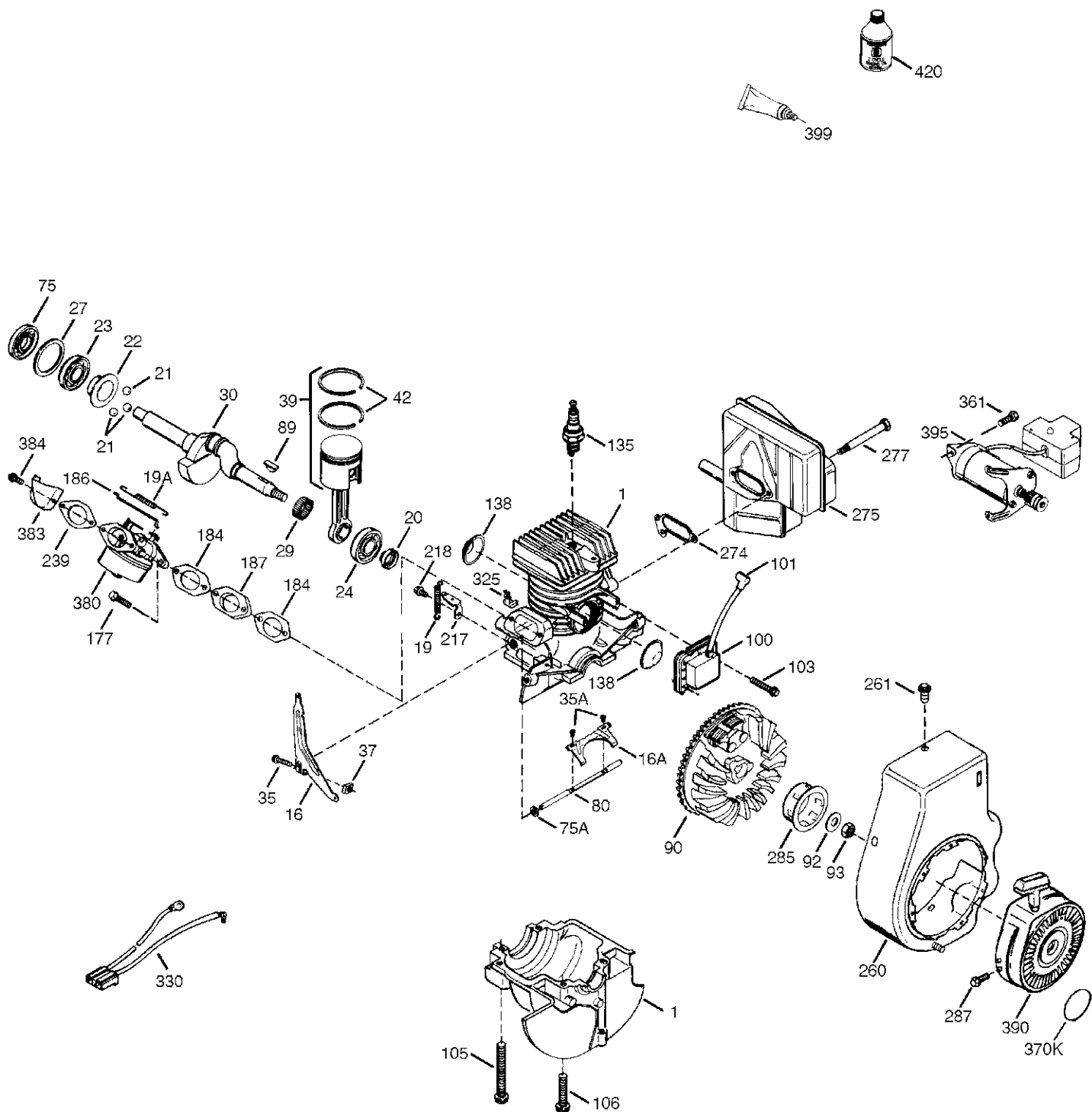

TECUMSEH 5 HP 2 CYCLE ENGINE HSK850-8330C REPAIR PARTS

MOTEUR 5 HP 2 TEMPS TECUMSEH HSK850-8330C PIÈCES DE RECHANGE

Key No. N° sur le schéma	Description	Description	Part No. N° de pièce
	RPM High 3700 to 4000	Régime maximal : 3700 à 4000 tr/min	
1	Cylinder Ass'y. (Incl. 75A, 105, 106, & 138)	Cylindre (comprend ref. 75A, 105, 106, & 138)	250296A
16	Governor Lever	Levier du régulateur	490317
16A	Governor Lever	Levier du régulateur	490304
19	Extension Spring	Ressort d'extension	570721
19A	Throttle Link Spring	Ressort de la tige du papillon	490318
20	Oil Seal	Joint à lèvres	510340
21	Ball Bearing	Roulement à billes	570673
22	Slide Ring	Segment coulissant	510338
23	Ball Bearing	Roulement à billes	530158
24	Ball Bearing	Roulement à billes	530161
27	Bearing Retainer	Capuchon de retenue de roulement	530159
29	Bearing Strip (31 Needles)	Manchon de roulement (31 aiguilles)	530164
30	Crankshaft	Vilebrequin	290627
35	Screw, 10-32 x 3/4"	Vis, 10-32 x 3/4 po.	29826
35A	Screw, 4-40 x 1/4"	Vis, 4-40 x 1/4 po.	650506
37	Lock Nut, 10-32	Écrou de blocage 10-32	29216
39	Piston & Rod Ass'y. (Incl. 29 & 42)	Piston et bielle (comprend ref. 29 & 42)	310277B
42	Ring Set	Segments	310278
75	Oil Seal	Joint à lèvres	510339
75A	Oil Seal	Joint à lèvres	510337
80	Governor Shaft	Arbre du régulateur	490305
89	Flywheel Key	Clavette du volant	611191
90	Flywheel	Volant	611192
92	Belleville Washer	Rondelle Belleville	650815
93	Flywheel Nut	Écrou du volant	650816
100	Solid State Ignition	Module d'allumage	34443B
101	Spark Plug Cover	Capuchon de bougie	610118
103	Screw, Torx T-15, 10-24 x 15/16"	Vis, Torx T-15, 10-24 x 15/16po.	651007
105	Screw, 5/16-18 x 2-3/16"	Vis, 5/16-18 x 2-3/16po.	650892
106	Screw, 5/16-18 x 1-5/8"	Vis, 5/16-18 x 1-5/8po.	650891
135	Resistor Spark Plug (RCJ8Y)	Bougie antiparasite (RCJ8Y)	611049
138	Port Cover	Couvercle d'orifice du cylindre	570683
177	Screw, 5/32 Allen, 1/4-20 x 1"	Vis, 5/32 Allen, 1/4-20 x 1po.	650959
184	Carburetor Gasket	Joint du carburateur	510326A
186	Governor Link	Tige du régulateur	490319
187	Spacer	Entretoise	570438A
217	Control Lever	Levier de commande du régime	570667A
218	Screw, 8-32 x 1/2"	Vis, 8-32 x 1/2po.	650847
239	Air Cleaner Gasket	Joint de l'épurateur d'air	35815
260	Blower Housing	Boîtier de soufflante	350460
261	Screw, 5/16-18 x 5/8"	Vis, 5/16-18 x 5/8po.	650894
274	Exhaust Gasket	Joint d'échappement	510343A
275	Muffler	Silencieux	390325
277	Screw, 5/16-18 x 3-13/64"	Vis, 5/16-18 x 3-13/64po.	650893
285	Starter Cup	Moyeu du démarreur	34449A
287	Screw, 8-32 x 21/64"	Vis, 8-32 x 21/64po.	650926
325	Wire Clip	Attache fil	29443
330	Wire Harness	Faisceau de câbles	611158
361	Screw, Torx T-30, 1/4-20 x 1/2"	Vis, Torx T-30, 1/4-20 x 1/2po.	30063
370K	Starter Decal	Autocollant, démarreur	36695
380	Carburetor (Incl. 184)	Carburateur (Incl. 184)	640088
383	Spit Cup	Coupelle de purge	570695
384	Screw, Torx T-25, 10-32 x 3/8"	Vis, Torx T-25, 10-32 x 3/8po.	650229
390	Rewind Starter	Démarreur à corde	590743
395	Electric Starter Motor (110 Volt)	Moteur de démarreur électrique	590670
399	Gasket Eliminator (Loctite 515)	Éliminateur de joint (Loctite 515)	510334
420	2-Cycle Oil (8 oz.)	Huile 2 temps (8 oz.)	730227A

* Indicates Parts Included in Gasket Set, Ref. No. 400

* Pièces incluses dans le lot de joints, réf. 400.

TECUMSEH 5 HP 2 CYCLE ENGINE HSK850-8330C

REPAIR PARTS

MOTEUR 5 HP 2 TEMPS TECUMSEH HSK850-8330C PIÈCES DE RECHANGE

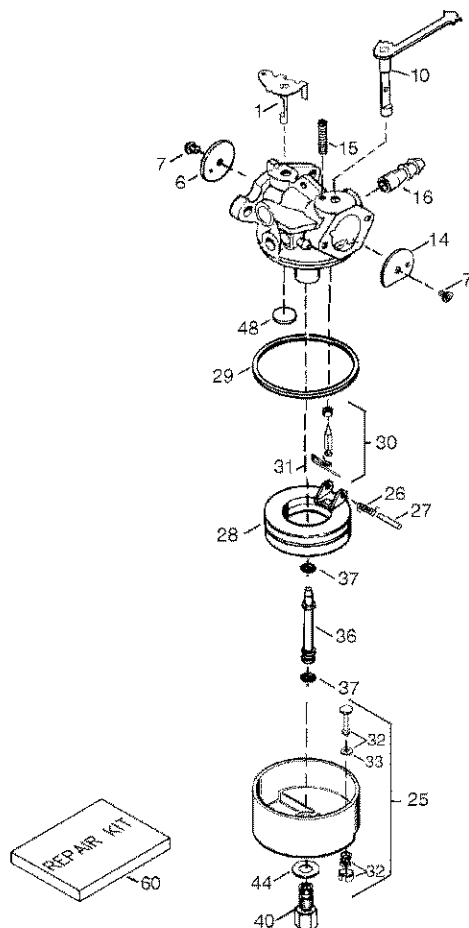

Key No.
N° sur le
schéma

Description

Description

Part No.
N° de pièce

0	Carburetor (Incl. 184 of Engine Parts List)	Carbureteur (comprend ref. 184 de la liste de pièces du moteur)	640088
1	Throttle Shaft & Lever Assembly	Axe et levier du papillon	632538
6	Throttle Shutter	Cache du papillon	631621
7	Shutter Screw	Vis de cache	650506
10	Choke Shaft & Lever Assembly	Axe et levier du volet de départ	632734
14	Choke Shutter	Cache du volet de départ	631815
15	Choke Positioning Spring	Ressort de butée du volet de départ	630735
16	Fuel Fitting	Raccord carburant	632164
25	Float Bowl Assembly (Incl. 32 & 33)	Joint torique cuve (comprend 32 & 33)	631951
26	Float Dampening Spring	Ressort de mouillage du flotteur	632386
27	Float Shaft	Axe du flotteur	631024
28	Float	Flotteur	632019
29	Float Bowl "O" Ring	Joint torique cuve du flotteur	631028
30	Inlet Needle, Seat & Clip (Incl. 31)	Pointeau, siège et arrêt (comprend 31)	631021
31	Spring Clip	Pince à ressort	631022
32	Bowl Drain Assembly	Vis de vidange cuve	27136A
33	Drain Plunger Gasket	Joint de la vis de vidange	27554
36	Main Nozzle Tube	Tube de l'injecteur principal	640080
37	"O" Ring, Main Nozzle Tube	Joint torique, Tube de l'injecteur principal	632547
40	High Speed Bowl Nut	Écrou cuve grande vitesse	640089
44	Bowl Nut Washer	Rondelle d'écrou cuve	27110A
48	Welch Plug, Atmospheric Vent	Pastille d'obturation, mise à l'air libre	631027
60	Repair kit (Incl. Items Marked PK in Notes)	Kit de réparation (comprend les articles marqués "PK" dans les Remarques)	632760

TECUMSEH 5 HP 2 CYCLE ENGINE HSK850-8330C

REPAIR PARTS

MOTEUR 5 HP 2 TEMPS TECUMSEH HSK850-8330C PIÈCES DE RECHANGE

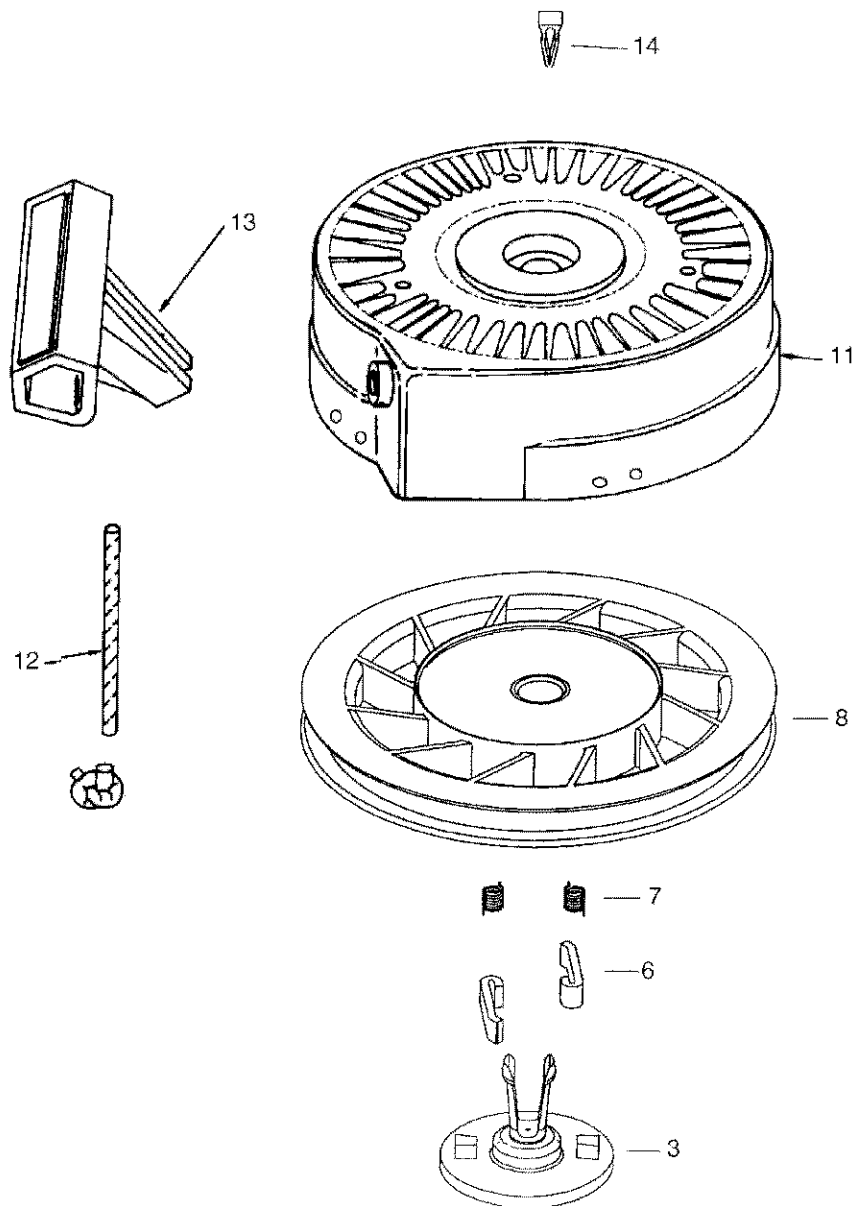

Key No.
N° sur le
schéma

Description

Description

Part No.
N° de pièce

0 Rewind Starter

Démarrateur à corde

590743

3 Retainer

Fixation

590740

6 Starter Dog

Doigt de démarreur

590616

7 Dog Spring

Ressort de doigt

590617

8 Pulley & Rewind Spring Ass'y

Poulie et ressort de rappel

590645A

11 Starter Housing Ass'y

Boîtier du démarreur

590643

12 Starter Rope (Length 98" x 9/64" dia.)

Corde de démarreur (longueur 98po. x diamètre 9/64po)

590535

13 Starter Handle

Poignée de démarreur

590701

14 Spring Clip

Pince à ressort

590760

NOTES



SEARS

*owner's
manual*

**Model
C950-52935-1**

**SINGLE STAGE
SNOW BLOWER**

CRAFTSMAN

**SERVICE
is at
YOUR
SERVICE**

Serial No. _____

Model and Serial Number may be found on the number plate on the rear of the Snow blower. You should record both Model and Serial Number and keep in a safe place for future reference.

HOW TO ORDER REPAIR PARTS

Each SNOW BLOWER has its own MODEL NUMBER Each ENGINE has its own MODEL NUMBER.

The MODEL NUMBER for the ENGINE will be found on the BLOWER HOUSING.

Always mention the MODEL NUMBERS when requesting service or Repair Parts for your SNOW BLOWER.

All parts list herein may be ordered through SEARS CANADA INC. RETAIL OR CATALOG STORES AND SERVICE CENTERS. If the parts you need are not stocked locally, your order will be electronically transmitted to a SEARS Parts Distribution Center for expedited handling.

When ordering parts by mail, selling prices will be furnished on request or parts will be shipped at prevailing prices and you will be billed accordingly.

WHEN ORDERING REPAIR PARTS, ALWAYS GIVE THE FOLLOWING INFORMATION:

1. PART NUMBER
2. PART DESCRIPTION
3. MODEL NUMBER
4. NAME OF THE ITEM-SNOW BLOWER
5. ENGINE MODEL NUMBER

Your Sears Merchandise takes on added value when you discover that Sears has Service Units throughout the Country Each is staffed by Sears-Trained, Professional technicians using Sears approved methods.

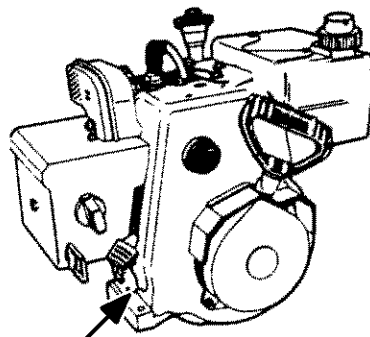

ENGINE MODEL DECAL

BLOWER MODEL DECAL

