

ASSEMBLY

IMPORTANT: This mower is shipped without gasoline or oil in the engine. Be certain to service engine with gasoline and oil as instructed in the Operation section of the Engine Manual before starting or operating your mower.

NOTE: Reference to right and left hand side of the Lawn Mower is observed from the operating position.

Unpacking

OPENING CARTON

1. Cut each corner of the carton vertically from top to bottom.
2. Remove all loose parts:
 - Grass Catcher (if equipped)
 - Engine Oil
3. Remove loose packing material.

REMOVING MOWER FROM CARTON

1. Lift mower from the rear to detach it from underlying carton material and roll mower out of carton.
2. Check carton thoroughly for any other loose parts.
3. Remove any packing material which may be between upper and lower handles.

Mower Assembly

Perform the following procedures to assemble and set up the mower:

• Handle Assembly

- Pull-Out Handle. See page 7.
- Folding Handle. See page 8.
- Vertical Storage Handle. See page 9.
- Recoil Starter Rope Handle Assembly
- Attaching the Grass Catcher (if equipped)
- Attaching Side Discharge Chute or Side Discharge Blower (if equipped)
- Electric Start Set-Up (If Equipped)

NOTE: If necessary, refer to the procedures in the Adjustments Section after assembling the mower.

Handle Assembly

PULL-OUT HANDLE

1. Remove knobs or wing nuts (a) and carriage bolts (b) from the handle or if equipped with the EZ-lock handle (c), proceed to STEP 2 (Figure 1).

NOTE: The EZ-Fold handle release levers are shipped in the unlocked position.

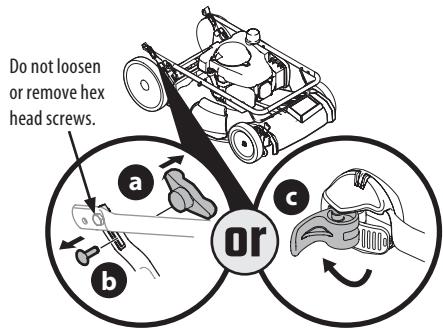

Figure 1

2. Remove T-bolts (d) from the handle brackets (Figure 2).
3. While stabilizing mower so it doesn't move, pivot upper handle (e) up (Figure 2). Do not crimp blade or drive control cables while lifting the handle up.

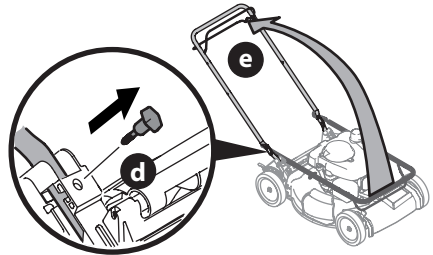

Figure 2

4. Pull upward on the handle (e) (Figure 3) until holes in lower handle (f) line up with holes in handle brackets (g) (Figure 3 Inset, Deck Cutaway).

NOTE: When pulling upward on handle, do not pull handle all the way out of the handle brackets.

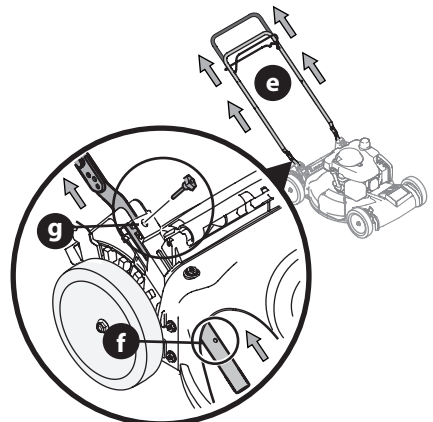

Figure 3

ASSEMBLY

5. Reattach knobs or wing nuts (a) and carriage bolts (b) removed in STEP 2 into lower holes of the handle or lock the EZ-fold handle release levers (c) (Figure 4).

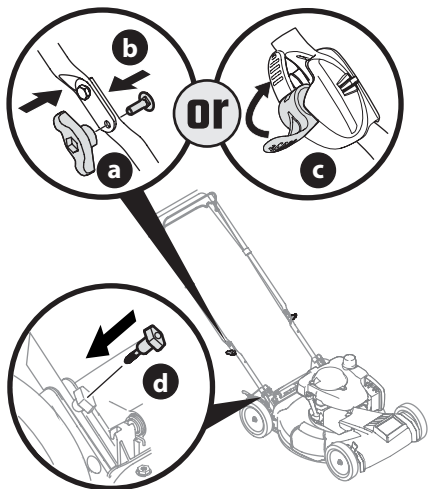

Figure 4

IMPORTANT: When locking the EZ-fold handle release lever (c) ensure the position indicator (h) aligns with one of three handle positions (i) (Figure 5).

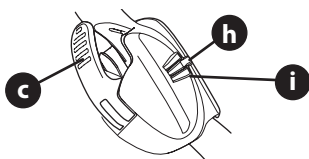

Figure 5

6. Insert the T-bolts (d) removed in STEP 4 through the handle brackets and lower handle (Figure 4) and tighten securely to secure the handle in place.

FOLDING HANDLE

1. Remove knobs or wing nuts (a) and carriage bolts (b) from the handle or if equipped with the EZ-lock handle (c), proceed to STEP 2 (Figure 6).

NOTE: The EZ-Fold handle release levers are shipped in the unlocked position.

Do not loosen or remove hex head screws.

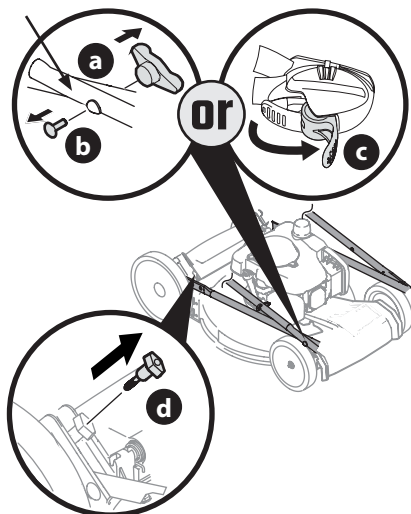

Figure 6

2. Remove the T-bolts (d) from the handle brackets (Figure 6).
3. While stabilizing mower so it doesn't move, gently lift and pivot the upper handle into the operating position (Figure 7). Make certain the lower handle is seated securely into the handle brackets. Do not crimp blade or drive control cables while lifting the handle up.

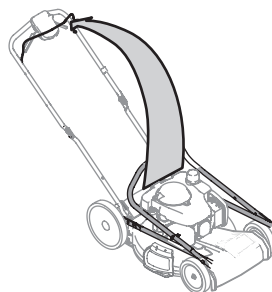

Figure 7

ASSEMBLY

- Reattach knobs or wing nuts (a) and carriage bolts (b) removed in STEP 2 into lower holes of the handle or lock the EZ-fold handle release levers (c) (Figure 8).

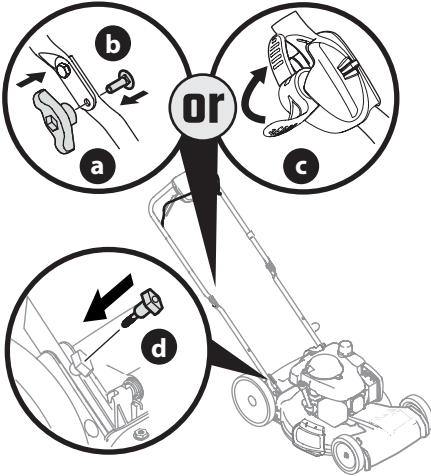

Figure 8

IMPORTANT: When locking the EZ-fold handle release lever (c) ensure the position indicator (e) aligns with one of three handle positions (f) (Figure 9).

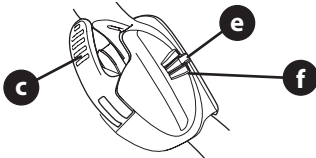

Figure 9

- Using the T-bolts (d) removed in STEP 2, secure the lower handle to the handle brackets (Figure 8) and tighten securely to secure the handle in place.

VERTICAL STORAGE HANDLE

- Remove the four carriage bolts and nuts from the lower handles (Figure 10).

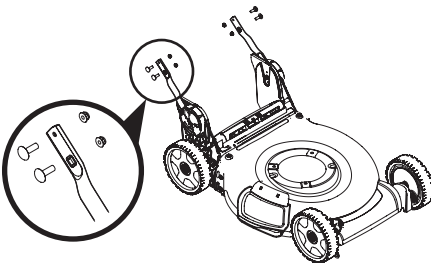

Figure 10

- Unlock the two handle release levers. See inset, Figure 11.

- Ensure the lower handles are folded forward towards the front of the mower.

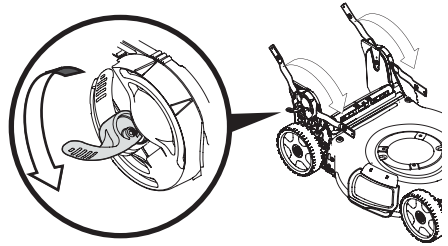

Figure 11

- Using the four carriage bolts and nuts removed in STEP 2, secure the upper handle to the lower handle. Tighten hardware securely to secure the handle in place (Figure 12).

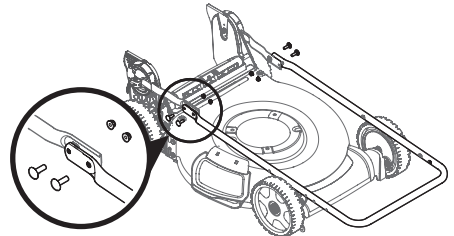

Figure 12

- While stabilizing mower so it doesn't move, lift the upper handle up (a) (Figure 13). Do not crimp blade or drive control cables while lifting the handle up.
- When lifting the upper handle ensure the position indicator (b) aligns with one of three handle positions (c). See inset, Figure 13.
- Lock the two handle release levers. See inset, Figure 13.
- Ensure all hardware is securely tightened.

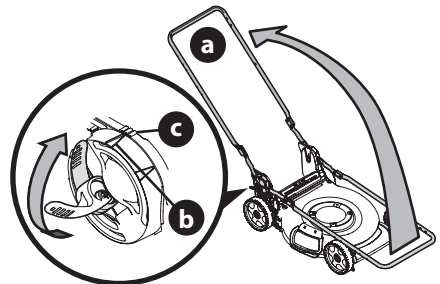

Figure 13

Recoil Starter Rope Handle Assembly

NOTE: The rope guide is attached to the right side of the upper handle. Loosen the knob securing the rope guide (Figure 14).

NOTE: Vertical Storage Mowers Only: The recoil starter rope is equipped with a rope stop clamp to prevent the starter rope being pulled into the engine. Do not remove the rope stop clamp.

1. Hold blade control against upper handle.
2. Slowly pull recoil starter rope handle from engine and slip starter rope into the rope guide.
3. Tighten rope guide knob.

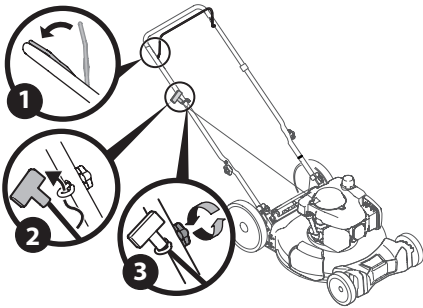

Figure 14

NOTE: On select units, use the two cable clips provided to secure blade control and drive cables to lower handle (Figure 15).

IMPORTANT: To reduce wear and allow for proper operation, make sure to leave some slack in the upper portion of the cables.

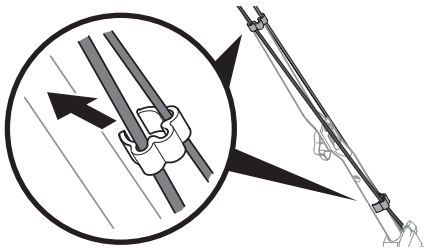

Figure 15

Attaching the Grass Catcher (If Equipped)

1. Perform the following to assemble the grass catcher (Figure 16).

NOTE: Before assembling the grass catcher, ensure the grass bag is turned right side out, with the warning label showing on the outside.

- a. Place bag over frame so that its black plastic side is at the bottom.
- b. Slip plastic channels (a) of grass bag over the frame (b).

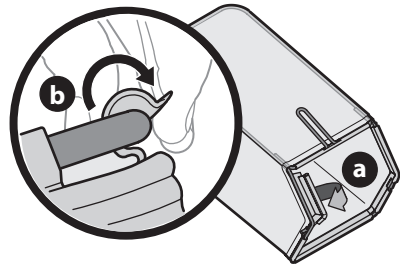

Figure 16

2. Follow steps below to attach grass catcher (Figure 17):
 - a. Lift rear discharge door (a).
 - b. Remove the rear mulch plug (b) (if equipped).
 - c. Place grass catcher into the slots in the handle brackets (c). Lower the discharge door so that it rests on the grass catcher.

NOTE: To remove grass catcher, lift rear discharge door on the mower. Lift grass catcher up and off the slots in the handle brackets. Reinstall the rear mulch plug (if equipped). Release rear discharge door to allow it to close rear opening of mower.

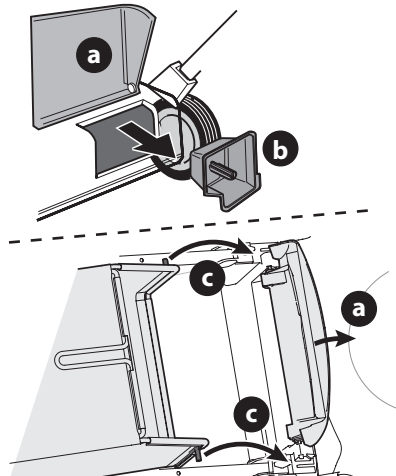

Figure 17

Attaching Side Discharge Chute or Side Discharge Blower (If Equipped)

The mower is shipped as a mulcher. To convert to side discharge or side discharge blower, ensure the grass catcher is removed, the rear mulch plug is installed (if equipped) and the rear discharge door is closed.

1. Lift the mulch plug (Figure 18).
2. Slide the two hooks of the side discharge chute (a) or side discharge blower (b) under the mulch plug hinge pin. Lower the mulch plug.

IMPORTANT: Do not remove side mulch plug at any time.

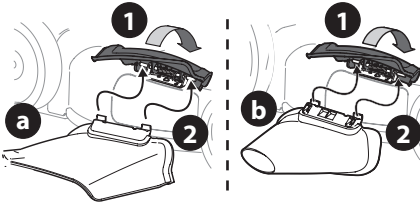

Figure 18

NOTE: Some side discharge chutes include a clip to secure the discharge chute to the handle. If equipped, the side discharge chute can be secured to the handle when not in use (Figure 19).

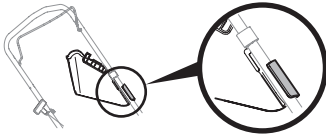

Figure 19

Electric Start Set-Up (If Equipped)

NOTE: Mowers equipped with electric start will use either a lead acid battery in an enclosed battery box (see Electric Starter Battery Box) or a removable lithium ion battery pack (See Installing/Removing Battery Pack).

ELECTRIC STARTER BATTERY BOX (IF EQUIPPED)

NOTE: Remove cable tie (a) from around battery box. Cable tie is used for shipping only (Figure 20).

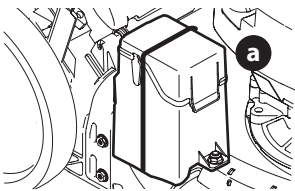

Figure 20

INSTALLING/REMOVING BATTERY PACK (IF EQUIPPED)

NOTE: To ensure maximum performance and life of lithium-ion battery packs, charge the battery fully before first use.

WARNING

Read all safety warnings, instructions, and cautionary markings for the battery pack, charger and product. Failure to follow the warnings and instructions may result in electric shock, fire and/or serious injury.

IMPORTANT: Refer to instructional manual supplied with battery charger for charging, maintenance and battery disposal instructions.

Installing The Battery Pack (Figure 21):

1. Lift the battery box cover.
2. Insert the battery pack into the battery box. An audible "click" will be heard when the battery is properly connected.
3. Close the battery box cover.

Removing The Battery Pack (Figure 21):

1. Lift the battery box cover.
2. Press the battery pack release button.
3. Pull the battery pack from the battery box.
4. Close the battery box cover.

Installing Battery Pack

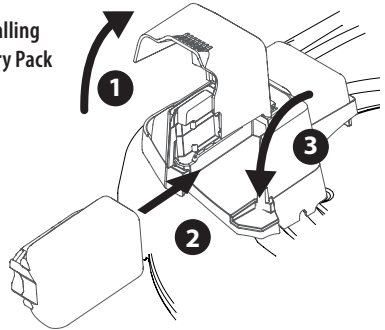

Removing Battery Pack

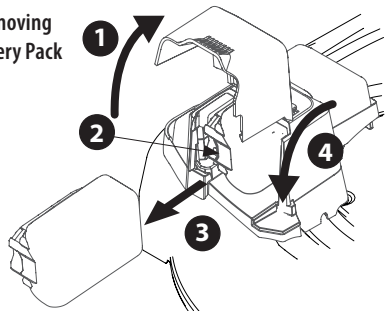

Figure 21