

Owner's Manual

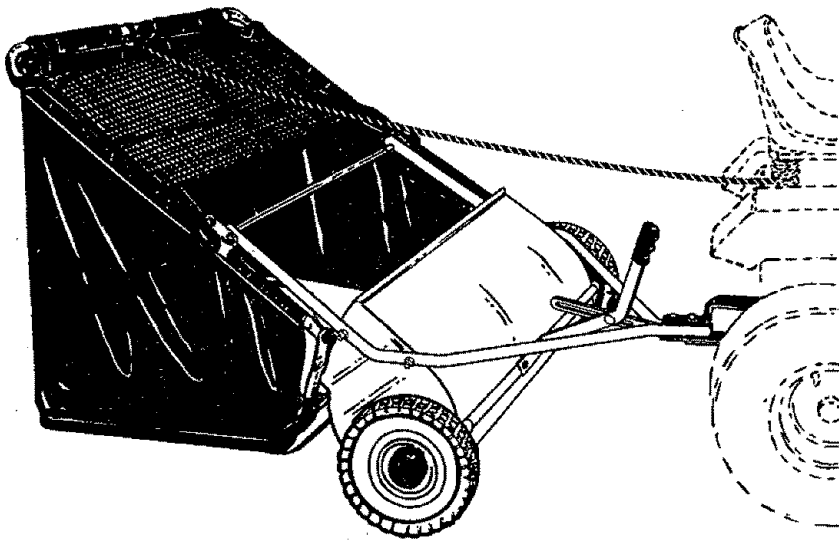

42" HIGH PERFORMANCE LAWNSWEEPER

Model No. 486.24211



CAUTION:

Before using this product, read this manual and follow all Safety Rules and Operating Instructions.

- Safety
- Assembly
- Operation
- Maintenance
- Parts

IMPORTANT - READ THIS FIRST!!!

For Missing Parts or Assembly Questions
Please Call 217-728-8388

Mon.-Fri. 7 am - 5 pm CST.

FAX 217-728-2032 or e-mail info@agri-fab.com

Missing parts will be sent UPS in 24 hours directly to your home.

Sears, Roebuck and Co., Hoffman Estates, IL 60179 U.S.A.
www.sears.com/craftsman

PRINTED IN U.S.A.

FORM NO. 46821 (REV. 8/01)

TABLE OF CONTENTS

| | | | |
|------------------------------------|----|--------------------------------|------------|
| Safety Rules..... | 2 | Maintenance Schedule..... | 12 |
| Full Size Hardware Chart..... | 3 | Storage..... | 12 |
| Carton Contents..... | 4 | Service and Adjustments..... | 13 |
| Sweeper Assembly Instructions..... | 5 | Troubleshooting..... | 13 |
| Hopper Assembly Instructions..... | 7 | Repair Parts Illustration..... | 14 |
| Know Your Sweeper..... | 11 | Repair Parts List..... | 15 |
| How To Use Your Sweeper..... | 11 | Parts Ordering/Service..... | Back Cover |

WARRANTY

LIMITED TWO YEAR WARRANTY ON CRAFTSMAN LAWSWEEPER

For two years from the date of purchase, when this Lawnsweeper is maintained and lubricated according to the operating and maintenance instructions in the owner's manual, Sears will repair free of charge any defect in material or workmanship.

This warranty does not cover repairs necessary because of operator abuse or negligence, including the failure to maintain the equipment according to instructions contained in the owner's manual; and Lawnsweeper used for commercial or rental purposes.

WARRANTY SERVICE IS AVAILABLE BY CONTACTING THE NEAREST SEARS SERVICE CENTER/DEPARTMENT IN THE UNITED STATES.

This warranty applies only while this product is in the United States.

This warranty gives you specific legal rights, and you may also have other rights which vary from state to state. Sears, Roebuck and Co. D/817WA, Hoffman Estates, Chicago, IL 60179



SAFETY



Any power equipment can cause injury if operated improperly or if the user does not understand how to operate the equipment. Exercise caution at all times, when using power equipment.

1. Read the vehicle and sweeper owners manuals and know how to operate your vehicle and sweeper before using this sweeper attachment. Always instruct other users before they operate the sweeper.
2. Do not permit children to operate sweeper.
3. Do not permit anyone to ride on sweeper.
4. Never attach the hopper rope to any part of your body or clothing! Never hold onto the rope while towing the sweeper! Attach the rope to the towing vehicle to keep it away from wheels and rotating parts.
5. Operate the sweeper at reduced speed on rough terrain, near ditches and on hillsides to prevent loss of control.
6. Vehicle braking and stability may be affected with the attachment of this sweeper. Do not fill sweeper to maximum capacity without checking the capability of the towing vehicle to safely pull and stop with the sweeper attached. **Stay off of steep slopes.**
7. Stop and inspect vehicle and sweeper for damage after striking an object. Repair any damage before continuing operation.
8. Keep sweeper away from fire. Excessive heat can damage the brushes and hopper bag and could cause the bag and its contents to burn.
9. Before storing the sweeper, always empty the hopper bag to avoid spontaneous combustion.
10. Follow maintenance and lubrication instructions as outlined in the maintenance section of this manual.



Look for this symbol to point out important safety precautions. It means--**Attention!! Become alert!!** Your safety is involved.

The model and serial numbers will be found on a decal attached to the lawnsweeper.

You should record both the serial number and the date of purchase and keep in a safe place for future reference.

MODEL NUMBER: 486.24211

SERIAL NUMBER: _____

DATE OF PURCHASE: _____

HARDWARE PACKAGE CONTENTS

SHOWN FULL SIZE

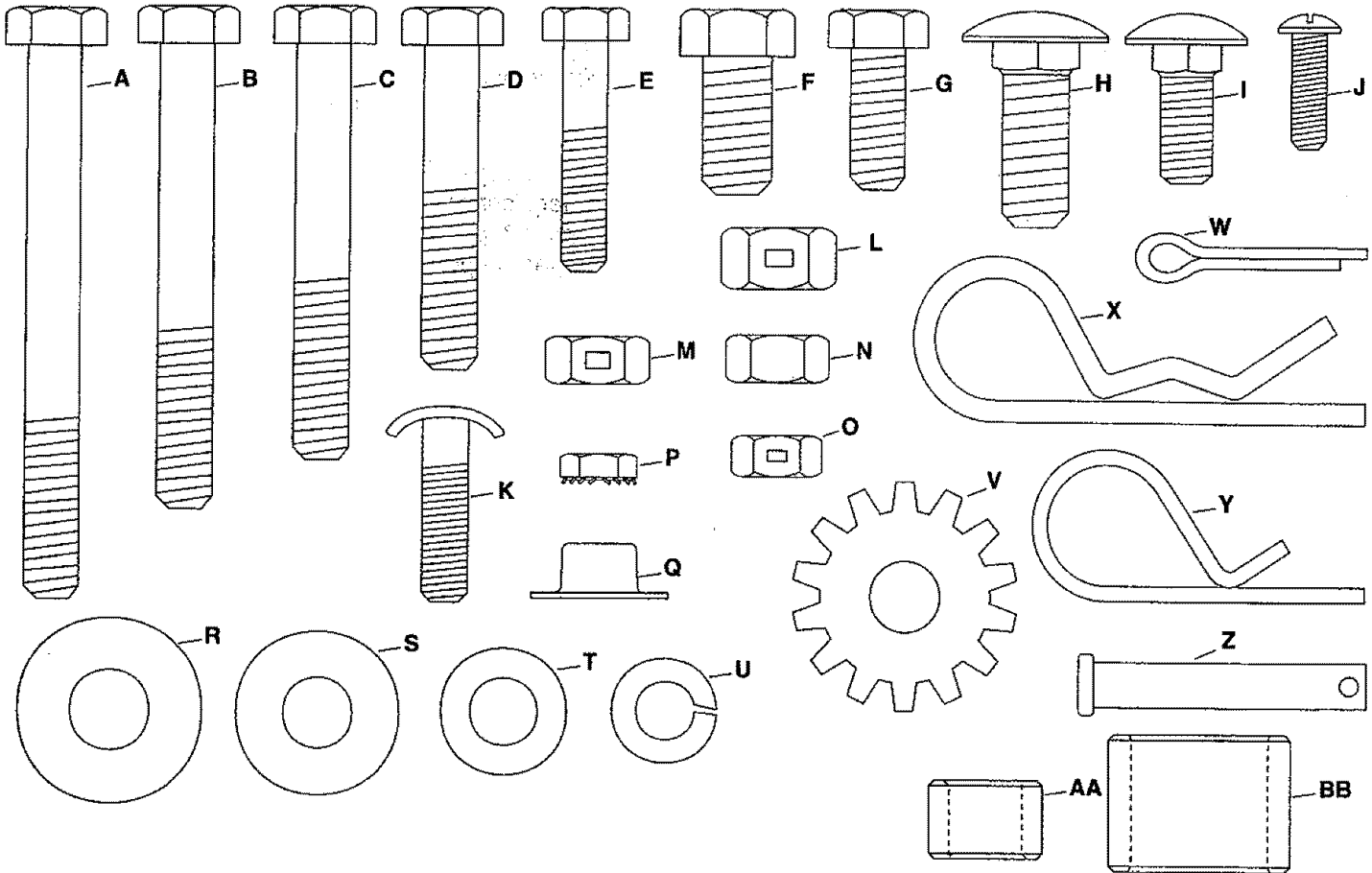

NOT SHOWN FULL SIZE

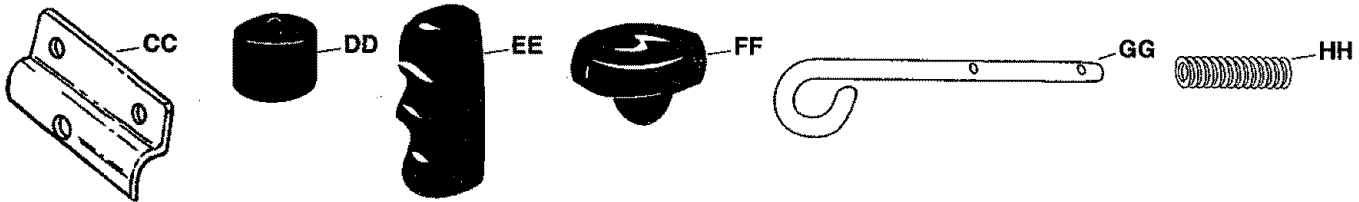

| REF. | QTY. | DESCRIPTION | REF. | QTY. | DESCRIPTION |
|------|------|-----------------------------------|------|------|-----------------------------|
| A | 2 | Hex Bolt, 5/16-18 x 3" Lg. | R | 1 | Flat Washer, 3/8" |
| B | 1 | Hex Bolt, 5/16-18 x 2-1/2" Lg. | S | 1 | Flat Washer, 5/16" Standard |
| C | 1 | Hex Bolt, 5/16-18 x 2-1/4" Lg. | T | 2 | Flat Washer, 5/16" (Small) |
| D | 4 | Hex Bolt, 5/16-18 x 1-3/4" Lg. | U | 6 | Lock Washer, 5/16" |
| E | 2 | Hex Bolt, 1/4-20 x 1-1/4" Lg. | V | 1 | Washer, Tooth Lock 5/16" |
| F | 2 | Hex Bolt, 3/8-16 x 3/4" Lg. | W | 1 | Cotter Pin, 1/8" x 3/4" |
| G | 4 | Hex Bolt, 5/16-18 x 3/4" Lg. | X | 1 | Hairpin Cotter, 1/8" |
| H | 1 | Carriage Bolt, 3/8-16 x 1" Lg. | Y | 2 | Hairpin Cotter, 3/32" |
| I | 1 | Carriage Bolt, 5/16-18 x 3/4" Lg. | Z | 2 | Clevis Pin, 1/4" x 1-1/2" |
| J | 6 | Slotted Screw, #10-32 x 5/8" Lg. | AA | 1 | Spacer Bushing, |
| K | 2 | Curved Head Bolt, 1/4-20 x 1" Lg. | BB | 2 | Hitch Spacer, 3/4" |
| L | 3 | Hex Lock Nut, 3/8" | CC | 4 | Hopper Mount Clamp |
| M | 8 | Hex Lock Nut, 5/16" | DD | 2 | Vinyl Cap |
| N | 4 | Hex Nut (Plain), 5/16" | EE | 1 | Grip |
| O | 4 | Hex Lock Nut, 1/4" | FF | 1 | Knob, Plastic |
| P | 6 | Hex Lock Nut, #10-32 | GG | 1 | Hitch Pin |
| Q | 2 | Palnut, 3/8" | HH | 1 | Spring |

ASSEMBLY

CARTON CONTENTS (Loose Parts in Carton)

1. Sweeper Housing Assembly
2. Bag Arm Tube (2)
3. Hitch Tube, L.H. (Left Hand)
4. Hitch Bracket
5. Hitch Bracket (Straight)
6. Hitch Pin Bracket
7. Height Adjustment Strap
8. Height Adjustment Handle
9. Hitch Tube, R.H. (Right Hand)
10. Rope
11. Hopper Bag
12. Windscreen
13. Upper Hopper Tube, R.H.
14. Upper Hopper Tube, L.H.
15. Lower Hopper Tube, R.H.
16. Lower Hopper Tube, L.H.
17. Hopper Bag Pivot Rod
18. Hopper Support Rod (2)
19. Bag Retaining Strap
20. Bag Frame Strap

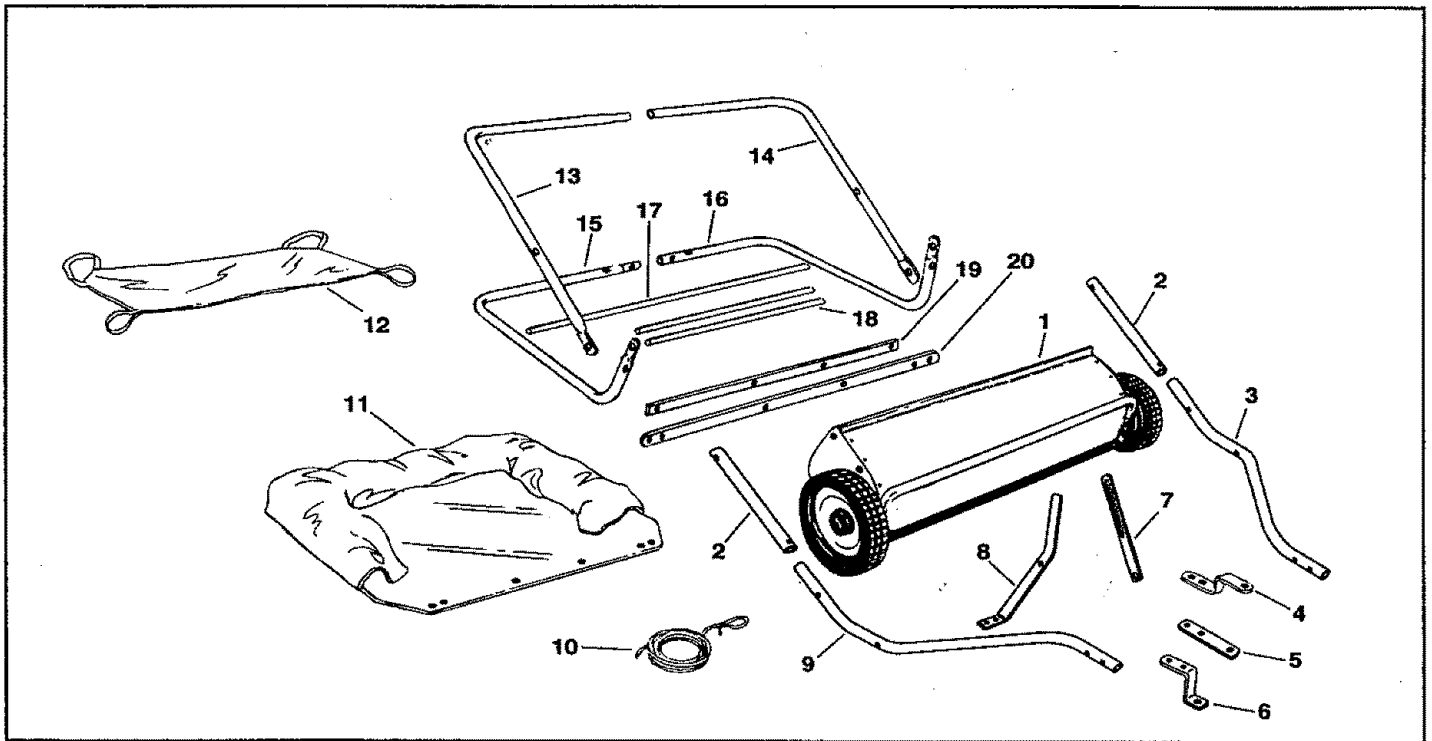

CARTON CONTENTS

REMOVAL OF PARTS FROM CARTON

- Remove the sweeper, the loose parts and the hardware package from the carton. Lay out the parts and hardware as shown on pages 3 and 4.

TOOLS REQUIRED FOR ASSEMBLY

- (1) Pliers
- (1) Screwdriver
- (1) Hammer
- (1) Adjustable Wrench
- (1) 9/16" Open End or Box End Wrench
- (1) 7/16" Open End or Box End Wrench
- (1) 1/2" Open End or Box End Wrench
- (1) 3/8" Open End or Box End Wrench

ASSEMBLY OF SWEEPER

Note: Right hand (R.H.) and left hand (L.H.) are determined from the operators position while seated on the tractor.

- Cut off the plastic tie holding the height adjustment tube in place. See figure 1.
- Assemble the R.H. and L.H. hitch tubes to the sweeper housing using four 5/16" x 1-3/4" hex bolts, 5/16" lock washers and 5/16" hex nuts. **Do not tighten yet.** See figure 1.

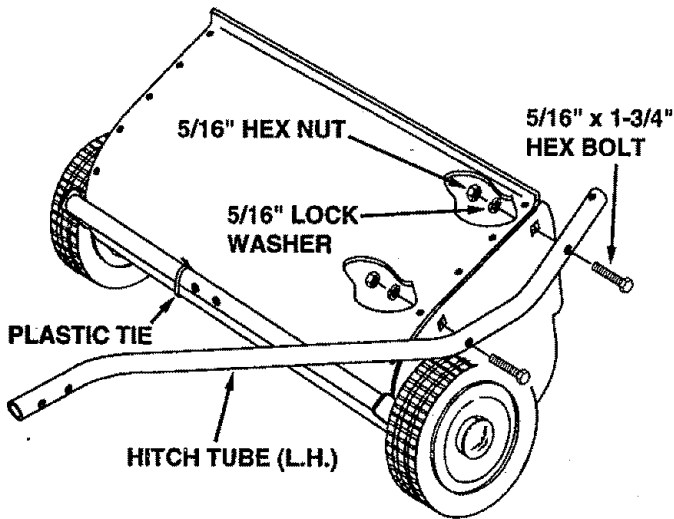

FIGURE 1

- Place the spacer bushing into the hole in the height adjustment strap. Place the strap with bushing between the hitch tubes, aligned with the rear hole. Fasten the hitch tubes together, with the strap and bushing between them, using two 5/16" x 3" hex bolts, 5/16" flat washers (smaller), 5/16" lock washers and 5/16" hex lock nuts. **Do not tighten yet.** See figure 2.

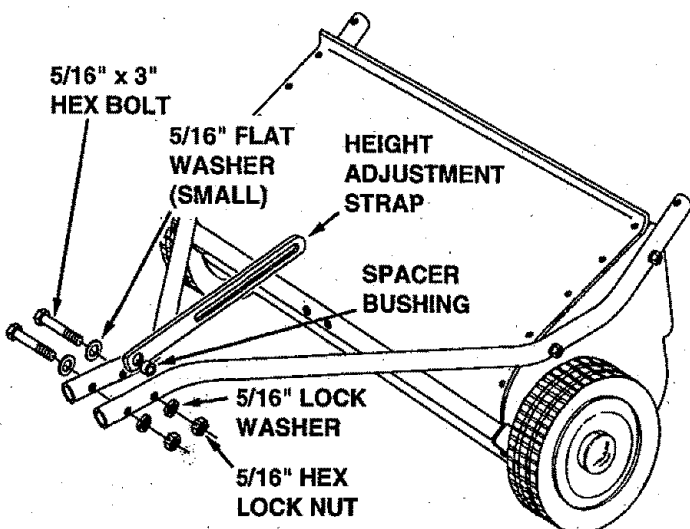

FIGURE 2

- Assemble the hitch pin bracket, the spring and the 3/8" flat washer onto the hitch pin. Secure them onto the hitch pin with a 1/8" x 3/4" cotter pin placed into the middle hole in the hitch pin. Spread ends of cotter pin around hitch pin. See figure 3.
- Assemble the hitch pin bracket to the straight hitch bracket using a 3/8" x 1" carriage bolt and a 3/8" hex lock nut. Align the brackets and **tighten**. See figure 3.

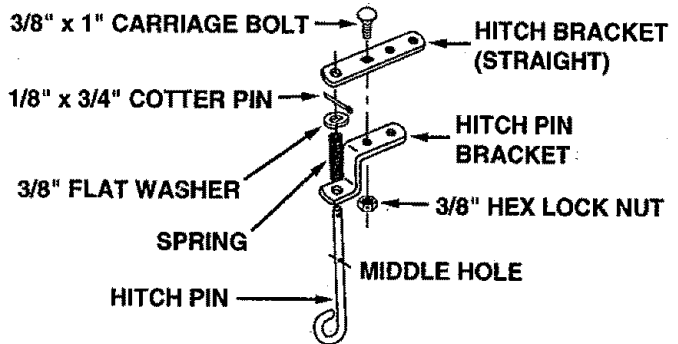

FIGURE 3

If your tractor hitch has 10" to 13" ground clearance use the instructions below to assemble the sweeper hitch brackets. If your tractor hitch has less than 10" ground clearance, go to page 6.

- Place the bent hitch bracket on top of the hitch tubes and place the straight hitch bracket with hitch pin underneath the hitch tubes. Fasten together using a 5/16" x 2-1/2" hex bolt (front), a 5/16" x 2-1/4" hex bolt (rear) and two 5/16" hex lock nuts as shown in figure 4. The bolts should straddle the front hitch tube bolt. **Do not tighten yet.**
- At this time **tighten** the four bolts fastening the hitch tubes to the sweeper housing. Next, **tighten** the two bolts fastening the hitch tubes together. Finally, **tighten** the two bolts fastening the hitch brackets to the hitch tubes.
- Assemble the two 3/4" spacers onto the hitch pin and secure the pin with the 1/8" hairpin cotter. See figure 4.

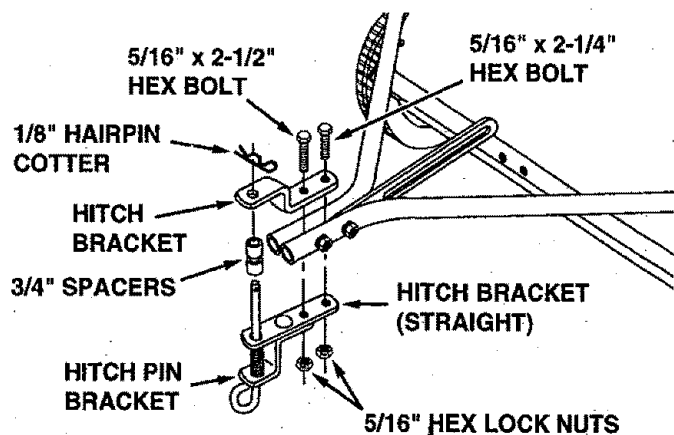

FIGURE 4

If your tractor hitch has 8" to 10" ground clearance, use the instructions below to assemble the sweeper hitch brackets. If your tractor hitch has more than 10" ground clearance, refer back to page 5 for the assembly of the sweeper hitch brackets.

- Place the bent hitch bracket underneath the hitch tubes and place the straight hitch bracket with hitch pin on top of the hitch tubes. Fasten together using a 5/16" x 2-1/2" hex bolt (front), a 5/16" x 2-1/4" hex bolt (rear) and two 5/16" hex lock nuts as shown in figure 5. The bolts should straddle the front hitch tube bolt. **Do not tighten yet.**
- At this time **tighten** the four bolts fastening the hitch tubes to the sweeper housing. Next, **tighten** the two bolts fastening the hitch tubes together. Finally, **tighten** the two bolts fastening the hitch brackets to the hitch tubes.
- Assemble the two 3/4" spacers onto the hitch pin and secure the pin with the 1/8" hairpin cotter. See figure 5.

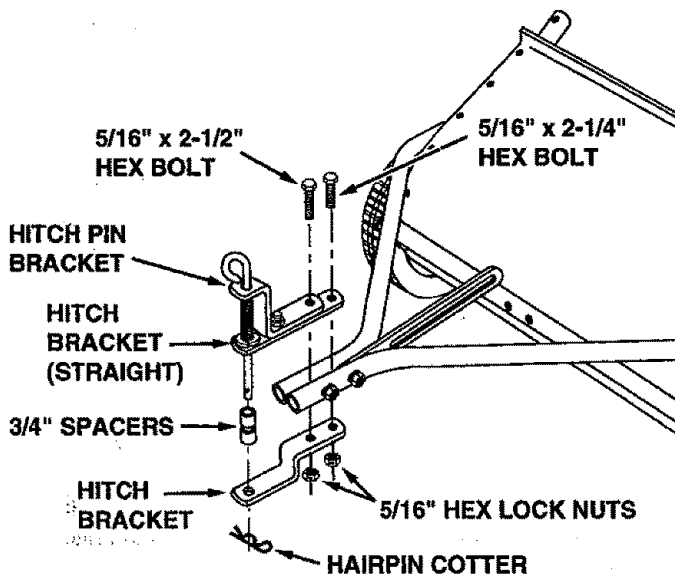

FIGURE 5

- Assemble the height adjustment handle to the height adjustment tube using the curved bolts, washers and nuts which come pre-assembled to the tube. Tighten the height adjustment handle so that the height adjustment strap is aligned with the outside of the handle. See figure 6.
- Assemble the grip onto the end of the height adjustment handle as shown in figure 6.

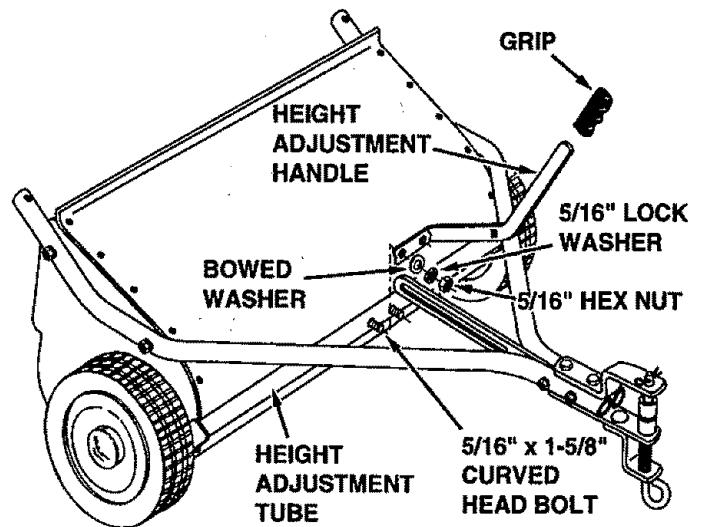

FIGURE 6

- Place the 5/16" tooth-lock washer between the height adjustment handle and the height adjustment strap. Insert the 5/16" x 3/4" carriage bolt through the handle, the tooth-lock washer and the strap. Assemble the 5/16" standard flat washer and the plastic knob onto the end of the bolt and tighten. See figure 7.

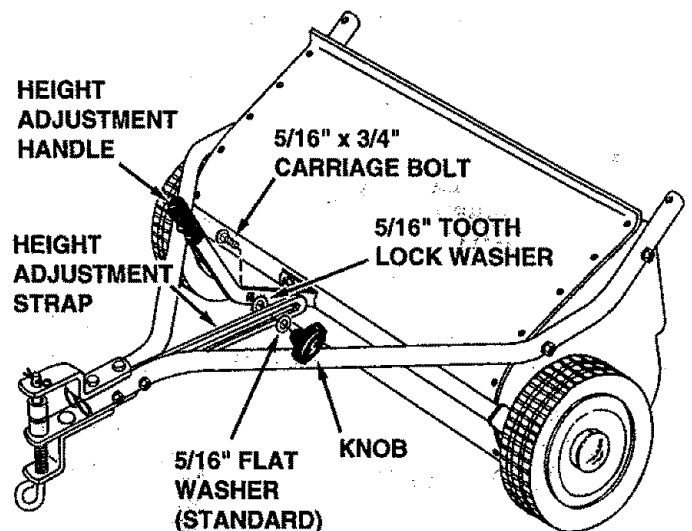

FIGURE 7

ASSEMBLY OF HOPPER BAG

- Insert the left hand upper hopper tube through the stitched flaps of the hopper bag, **starting at the center cut out** in the top of the bag. See figures 8, 9 and 10. Repeat for the right hand upper hopper tube.

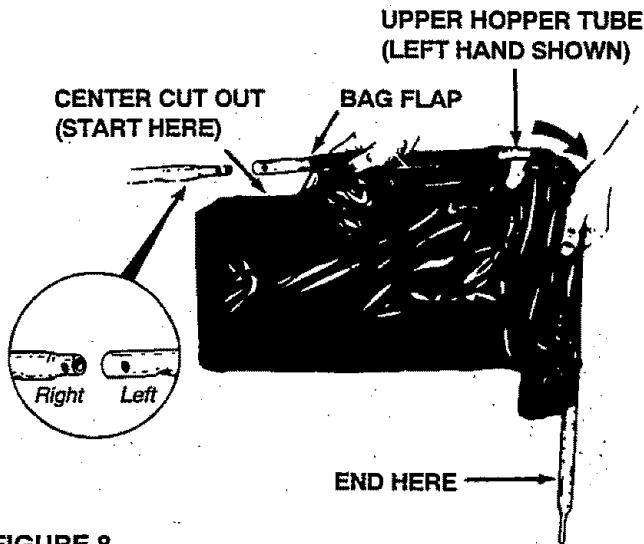

FIGURE 8

- Slide the two upper hopper tubes together and line up the center holes as shown in figure 9.

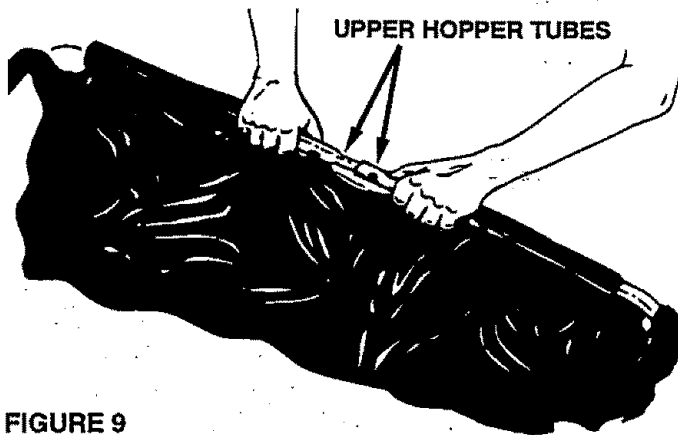

FIGURE 9

- Fasten the upper hopper tubes together using a 1/4" x 1" curved head bolt and a 1/4" hex lock nut. See figure 10.

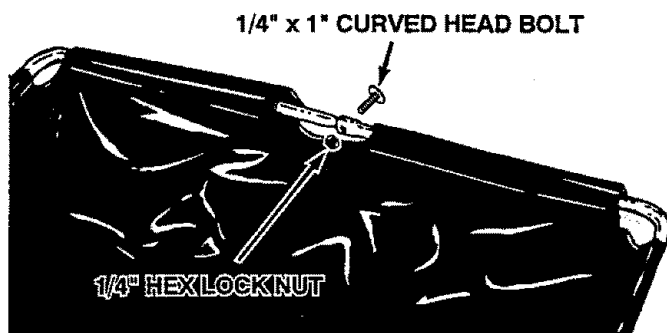

FIGURE 10

- Assemble the two lower hopper tubes together using a 1/4" x 1" curved head bolt and a 1/4" hex lock nut. See figure 11.

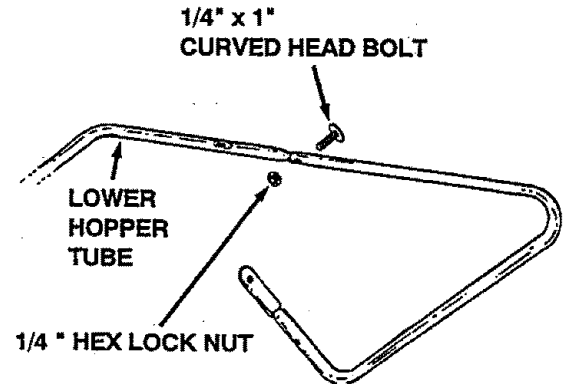

FIGURE 11

- Place the assembled lower hopper tubes into the bottom of the hopper bag as shown in figure 12.
- Assemble the ends of the upper and lower hopper tubes together using two 3/8" x 3/4" hex bolts (on the inside) and two 3/8" hex lock nuts (on the outside). Tighten to allow bag to pivot freely. See figure 12.

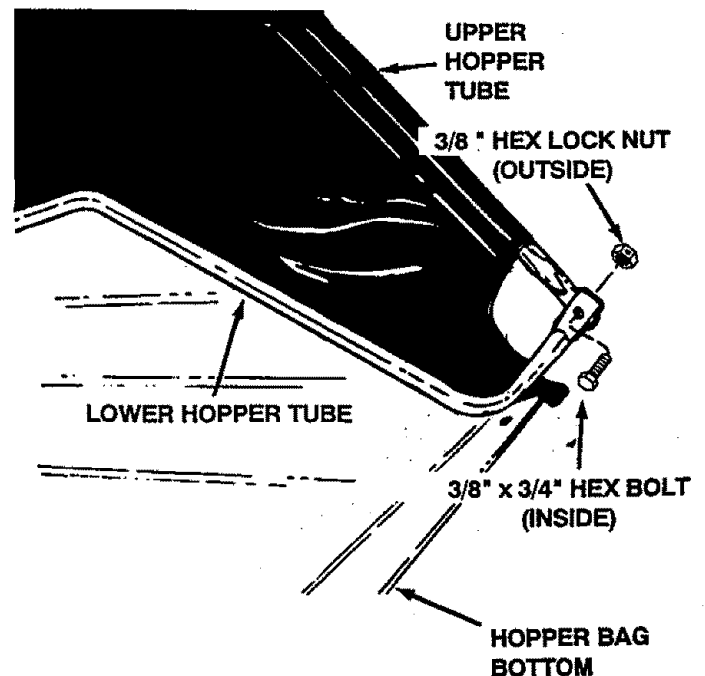

FIGURE 12

- Assemble the bag retainer and the bag frame strap to the front edge of the bag bottom. Place the bag retainer on top and the bag frame strap underneath the bag bottom. Fasten together using six #10 x 5/8" slotted screws and #10-32 hex lock nuts. See figure 13.

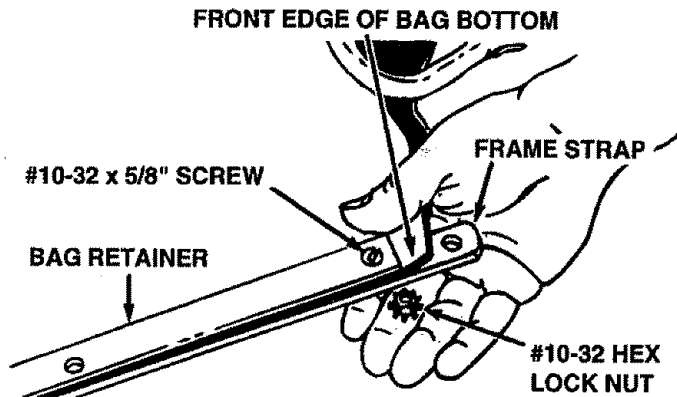

FIGURE 13

- Assemble the frame strap to the lower hopper tube using two 1/4" x 1-1/4" hex bolts and 1/4" hex lock nuts. See figure 14.

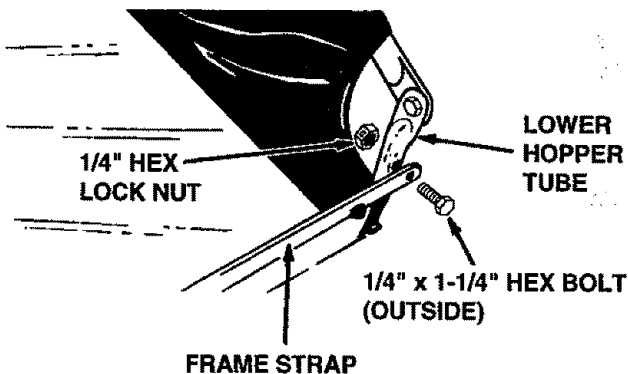

FIGURE 14

- Secure the bag corners over the lower hopper tube by snapping the flap to the bag bottom on both sides. See figure 15.

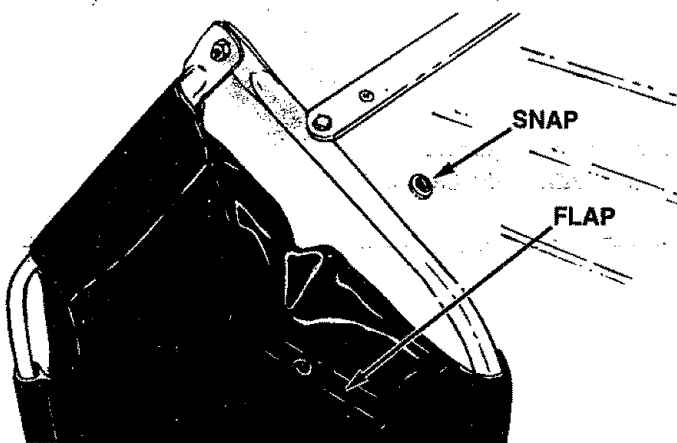

FIGURE 15

IMPORTANT: Do not over bend the support rods during the following step. Over bending will cause the spring steel rods to loose supporting tension.

- Assemble the two hopper support rods as shown in figure 16. Place end of rod into hole in upper hopper tube and bend rod just enough to fit bottom end of rod into hole in bottom hopper tube.

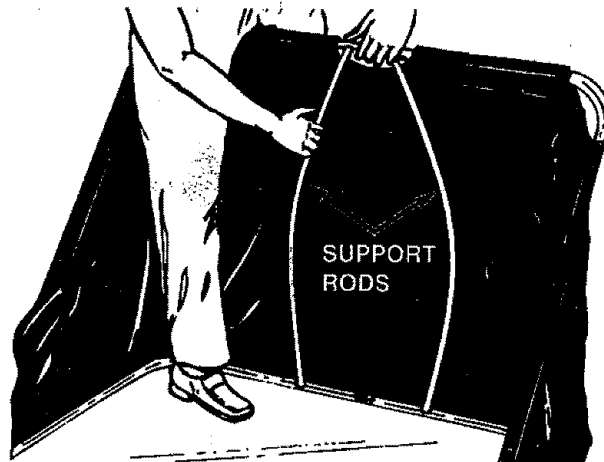

FIGURE 16

- Locate (by touch) the hole in each upper hopper tube, approximately midway along the side of the bag. Pierce holes through the stitched bag flaps, aligned with the holes in both hopper tubes. See figure 17.

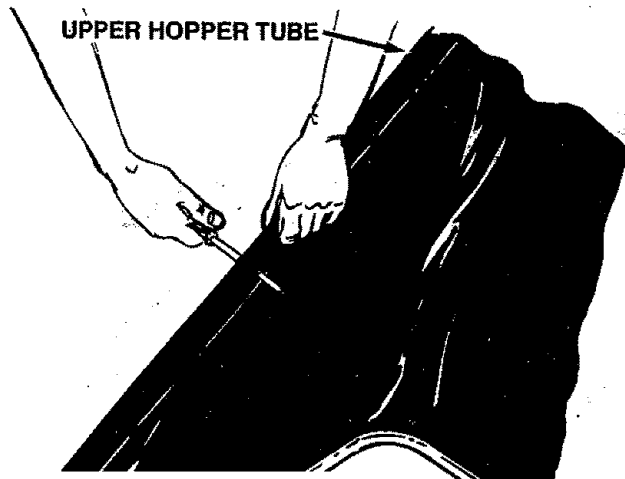

FIGURE 17

- Assemble a vinyl cap onto each bag arm tube as shown in figure 18.

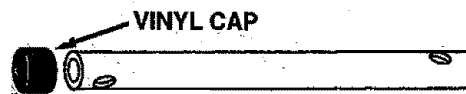

FIGURE 18

- Slide the hopper bag pivot rod through the side of an upper hopper tube where the hole was pierced. Assemble onto the rod a mounting clamp, two bag arm tubes and another mounting clamp as shown in figure 19. Push the rod on through the upper hopper tube on the opposite side of the bag.

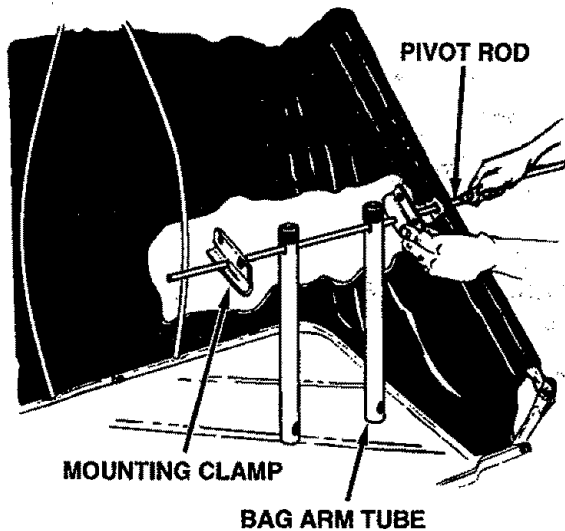

FIGURE 19

- Assemble the two remaining hopper mount clamps onto the pivot rod on the outside of the bag. Fasten them to the inside clamps using four 5/16" x 3/4" hex bolts and 5/16" hex lock nuts. Tighten securely. See figure 20.
- Assemble two palnuts by lightly tapping them onto the ends of the pivot rod with a hammer. See figure 20.

HINT: To ease assembly of the palnuts, place the bag on its side on a hard surface. With the bottom end of the pivot rod against the surface, tap a palnut onto the top end of the rod. Repeat for other end of rod.

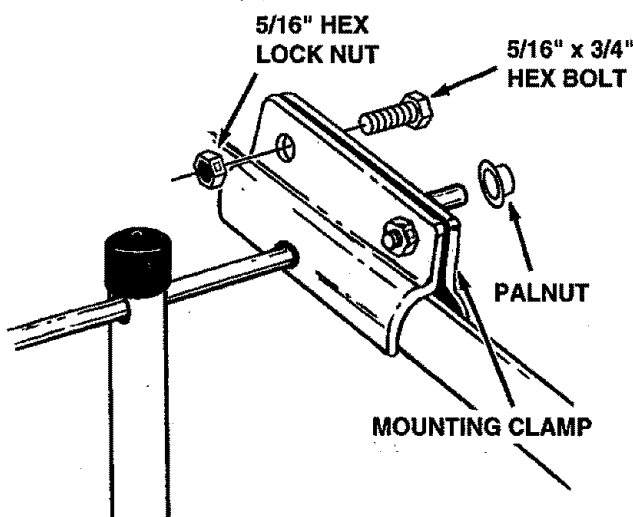

FIGURE 20

- Secure the rope to the top center of the hopper bag frame as shown in figure 21.

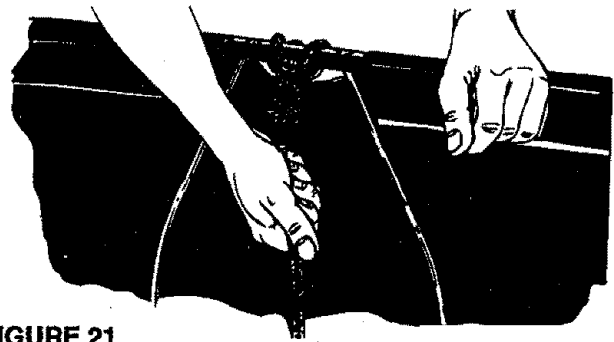

FIGURE 21

- Assemble the wind screen to the hopper bag frame by hooking the bag's top corner loops over the upper hopper tube and then pulling the bag's bottom loops down over the ends of the pivot rod. See figure 22.

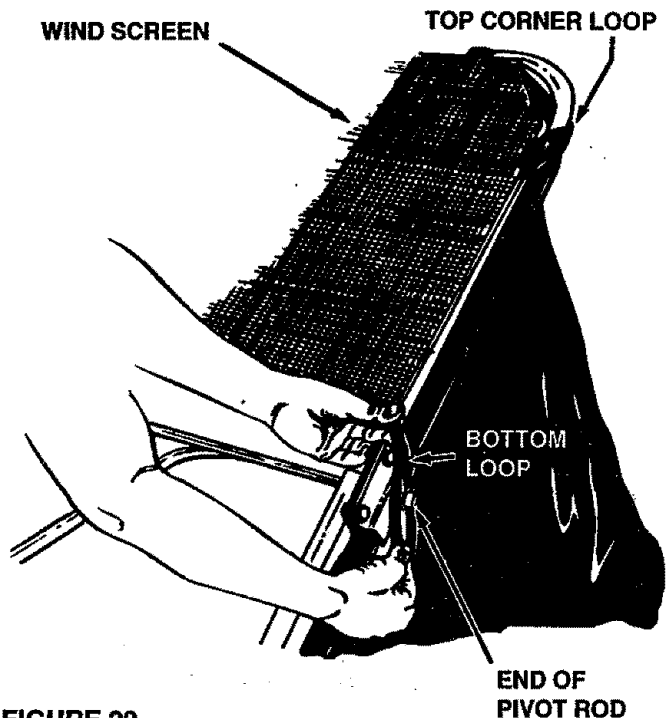

FIGURE 22

- To assemble the hopper bag to the sweeper, slide the ends of the bag arm tubes into the ends of the hitch tubes and secure with two 1/4" x 1-1/2" clevis pins and 3/32" hairpin cotters. See figure 23.

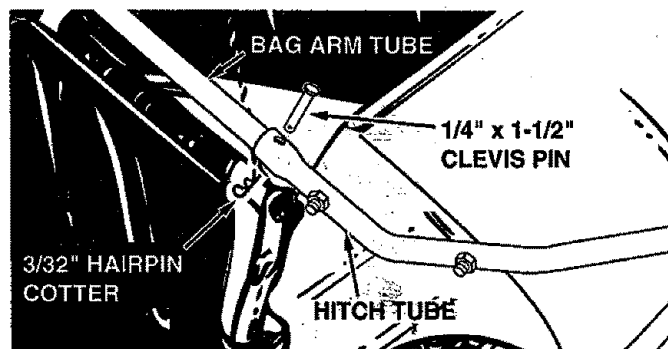

FIGURE 23

ATTACHING SWEEPER HITCH TO TRACTOR

- Place the tractor and sweeper on a flat level surface.
- Set the sweeper height adjustment handle to about the middle of its adjustment range.
- Attach the sweeper hitch to the tractor hitch, arranging the 3/4" spacers in one of six possible combinations as shown in GROUP A and GROUP B diagrams below.

IMPORTANT: To obtain the best performance from your sweeper, arrange the spacers so that the sweeper bag is approximately level with the ground and approximately 5" to 7" off the ground as shown in figure 24.

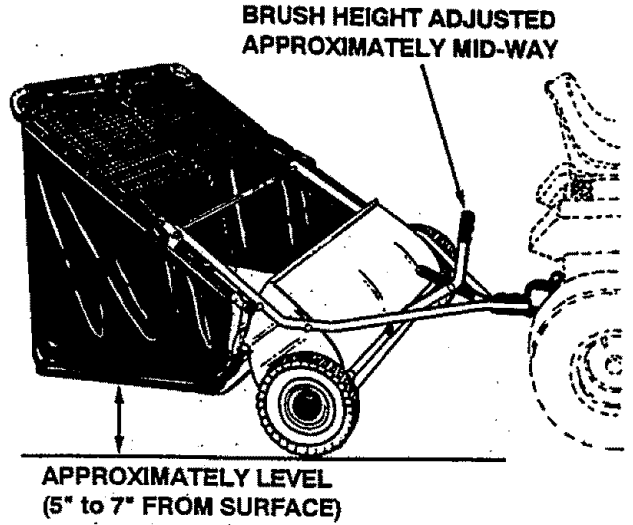
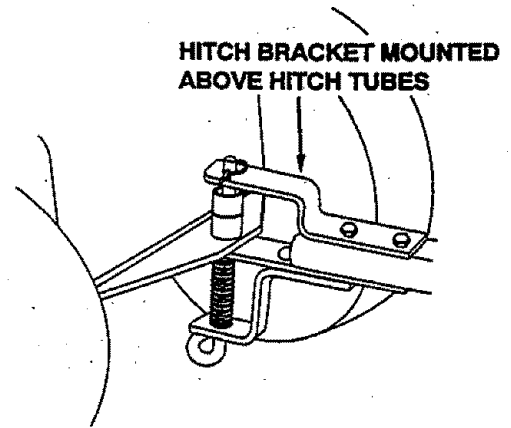
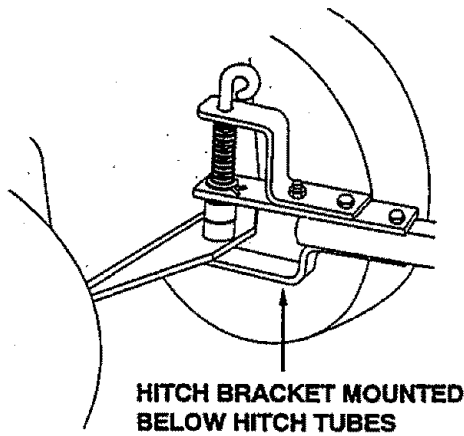

FIGURE 24

GROUP "A" - For vehicles with hitches having 8" to 10" ground clearance.

GROUP "B" - For vehicles with hitches having 10" to 13" ground clearance.



BLACK LINE IS TRACTOR HITCH

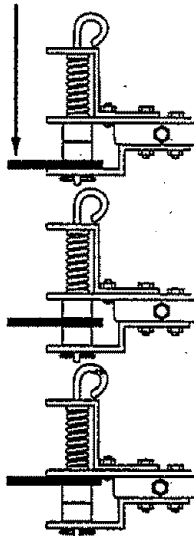

BLACK LINE IS TRACTOR HITCH

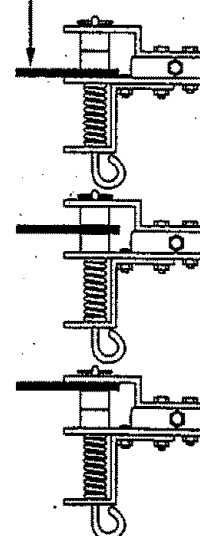

OPERATION

KNOW YOUR SWEEPER

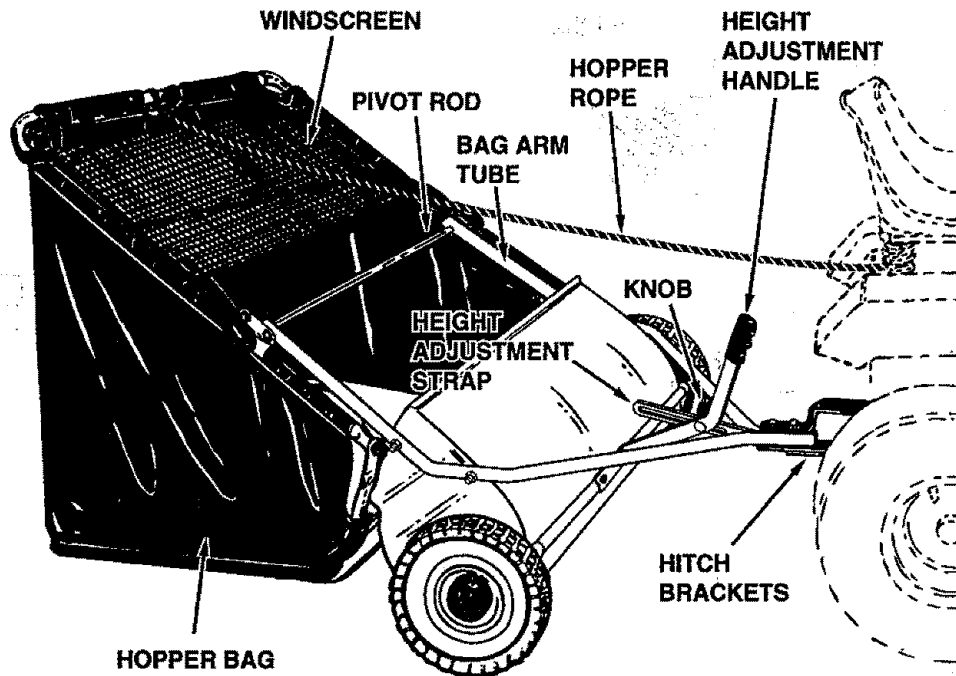

| | |
|--------------------------|---|
| Hopper Bag | Collects grass clippings, leaves and debris. |
| Hopper Rope | Permits dumping of hopper bag from driver's seat. |
| Windscreen | Helps prevent collected material from being blown out of hopper bag. |
| Bag Arm Tubes | Connects the hopper bag to the sweeper housing. |
| Pivot Rod | Allows hopper bag to tilt forward to dump material. |
| Height Adjustment Handle | Adjusts the operating height of the sweeper. |
| Height Adjustment Strap | Holds the height adjustment handle in position when locked. |
| Knob | Locks the height adjustment handle to the height adjustment strap. |
| Hitch Bracket | Connects the sweeper to the towing vehicle. Adjusts for various height tractor hitches. |

HOW TO USE YOUR SWEEPER

BRUSH HEIGHT ADJUSTMENT

- To adjust your sweeper brushes to the best operating height, loosen the adjustment knob and push down on the height adjustment lever to raise the brush, or push up on the lever to lower the brush. See figure 24. Best adjustment is when the brush setting is 1/2" down into the grass. Always mow the grass to an even height before sweeping.

SWEEPING SPEED

- Try a starting speed of approximately 3 m.p.h. (third gear on most tractors). Depending on the conditions, may be necessary to adjust the sweeping speed in order to achieve best results.

DUMPING OF SWEEPER

- Your sweeper can be dumped easily without getting off of the rider or tractor. Simply pull the rope forward to dump the hopper. Always empty hopper after each use.



CAUTION: Never attach the hopper rope to any part of your body or clothing! Never hold onto the rope while towing the sweeper! Attach the rope to the towing vehicle to keep it away from wheels and rotating parts.



CAUTION: Keep sweeper away from fire. Excessive heat can damage the brushes and hopper bag and could cause the bag and its contents to burn.

MAINTENANCE

CUSTOMER RESPONSIBILITIES

- Read and follow the maintenance schedule and the procedures listed in the maintenance section.

| MAINTENANCE SCHEDULE Fill in dates as you complete regular service. | Service Dates | | | | | | | | | | | |
|--|-----------------|----------------|--------------|--------------|----------------|-----------------|--|--|--|--|--|--|
| | Before each use | After each use | Twice a year | Every season | Before storage | Every two years | | | | | | |
| Check for loose fasteners | X | | | | | | | | | | | |
| Check for worn or damaged parts | X | | X | | | | | | | | | |
| Lubricate brush shaft bearings | | X | | | | | | | | | | |
| Lubricate wheel bearings | | | X | | | | | | | | | |
| Clean Sweeper | | X | | X | | | | | | | | |
| Clean/Lubricate chain and sprockets | | | | | X | | | | | | | |

SCHEDULED MAINTENANCE

- Clean the sweeper after each use. Inspect for worn or damaged parts, such as brushes and wheels.
- Lubricate the brush shaft bearing twice a year with a few drops of light weight oil. See figure 25.

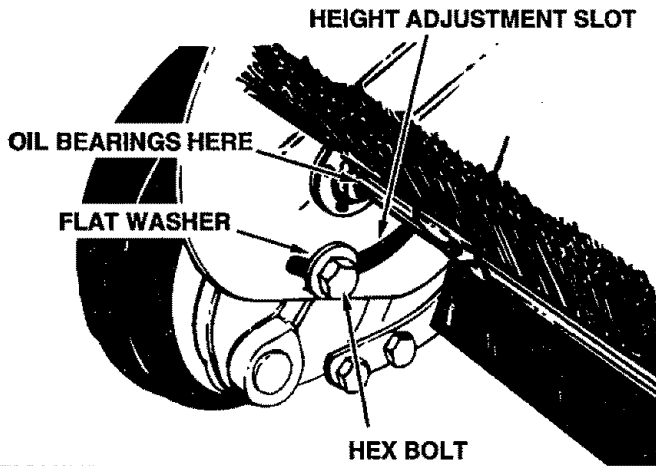

FIGURE 25

- Every two years, remove the wheels and clean the sprockets, chains and gears found inside the wheel housing. After cleaning, lubricate with an even coat of light grease. To remove the wheel, pop off the hub cap using a screwdriver and remove the lock nut and flat washer. See figure 26.

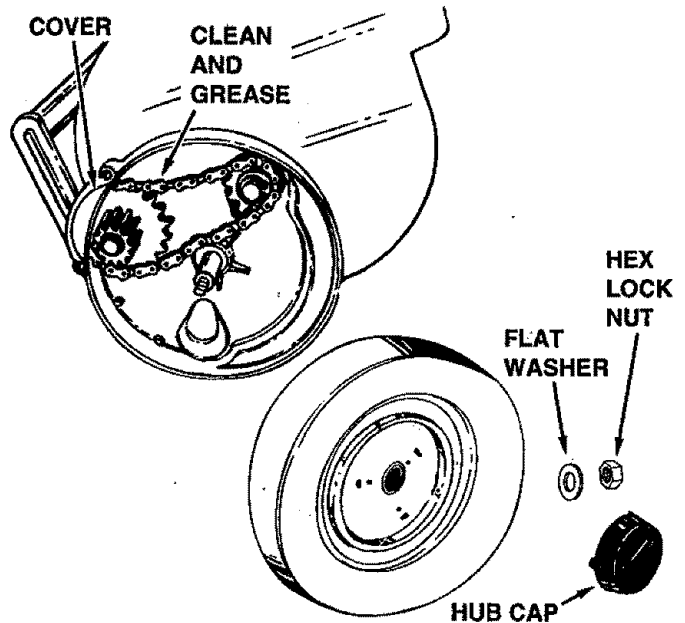

FIGURE 26

CLEANING

- Clean sweeper housing with a soft brush or cloth.
- Clean debris from hopper bag with a brush or broom.
- Remove any material which has wrapped around brushes or ends of brush shaft.

STORAGE



CAUTION: Before storing the sweeper, always empty the hopper bag to avoid spontaneous combustion.

- Clean the sweeper and hopper bag thoroughly to help prevent rust and mildew.
- To collapse the hopper bag for storage, remove the two hopper support rods from the rear of the hopper.
- Store in a dry area.

SERVICE AND ADJUSTMENTS

BRUSH REPLACEMENT

NOTE: Brush replacement should be done one brush at a time.

- Remove the hopper bag from the sweeper.
- Loosen the hex bolts and lock nuts on two single brush retainers which clamp one brush to the double brush retainers. **Do Not loosen** or remove the bolts which fasten the double brush retainers to the brush shaft. See figure 27.
- Slide the brush out of the retainers, noting on which side of the brush the bristles overlap. See figure 27.
- Install new brush, making sure the bristles overlap on the same side of the brush as before. See figure 27.

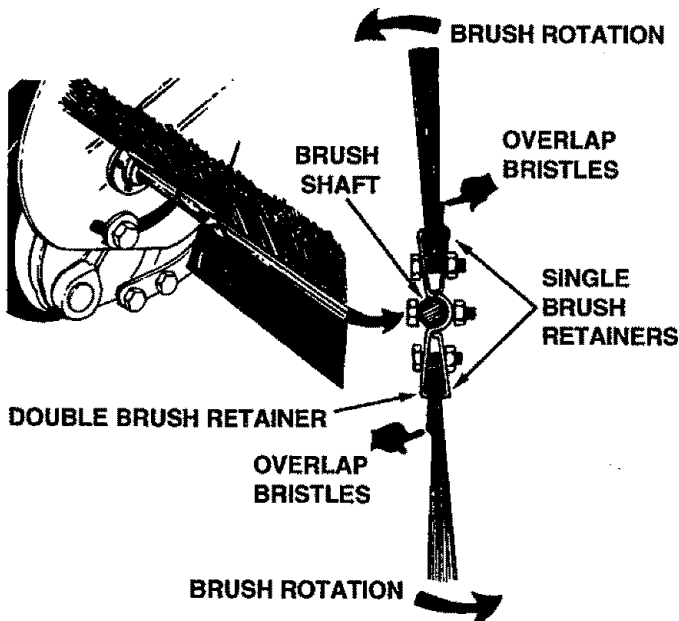

FIGURE 27

SPROCKET, CHAIN AND PAWL SERVICE

IMPORTANT: Do not remove both wheels at the same time to avoid mixing of parts. (The R.H. and L.H. ratchet sprockets are not interchangeable.) **Make notes** on the position of washers and snap rings during disassembly.

- Remove the dust cover by removing the two rivets which fasten it to the wheel housing. (It is not necessary to remove the dust cover if you are only cleaning and lubricating the chain and sprockets.)
- Remove the retaining rings and washers which hold the sprockets onto the shafts.
- Remove the chain and both sprockets, holding them in position and sliding them off both of the shafts. (Look for the drive pin, which may fall out of the brush shaft when the ratchet sprocket is removed.) See figure 28.
- To reassemble, insert the drive pin through the hole at the end of the brush shaft. Make sure the pin slides back and forth easily in the shaft.
- Lightly grease both shafts and the chain, and fill the ratchet sprocket with grease. Assemble the chain with both sprockets back onto the shafts.
- Lightly grease the axle and then reassemble the wheel. The brushes should rotate **only** during forward rotation of the wheel. If the brushes are driven (rotated) by both forward and reverse rotation of the wheel, the drive pin is jamming in the ratchet gear. Disassemble and clean and lubricate the drive pin and ratchet gear.

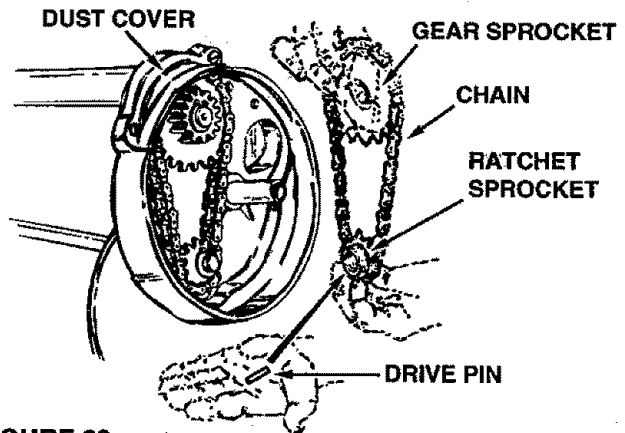

FIGURE 28

TROUBLESHOOTING

Wheels skid when sweeping.

- | | |
|--|---|
| <ul style="list-style-type: none"> ● Brushes set too low. ● Brushes are jammed ● Wheels are jammed. | <ul style="list-style-type: none"> ● Adjust height till brushes are 1/2" down into grass. ● Stop sweeper. Remove obstruction. ● Remove one wheel at a time to check for obstruction or damage. Refer to Service and Adjustments section. |
|--|---|

PARTS

REPAIR PARTS FOR MODEL 486.24211 - 42" HIGH PERFORMANCE LAWSWEEPER

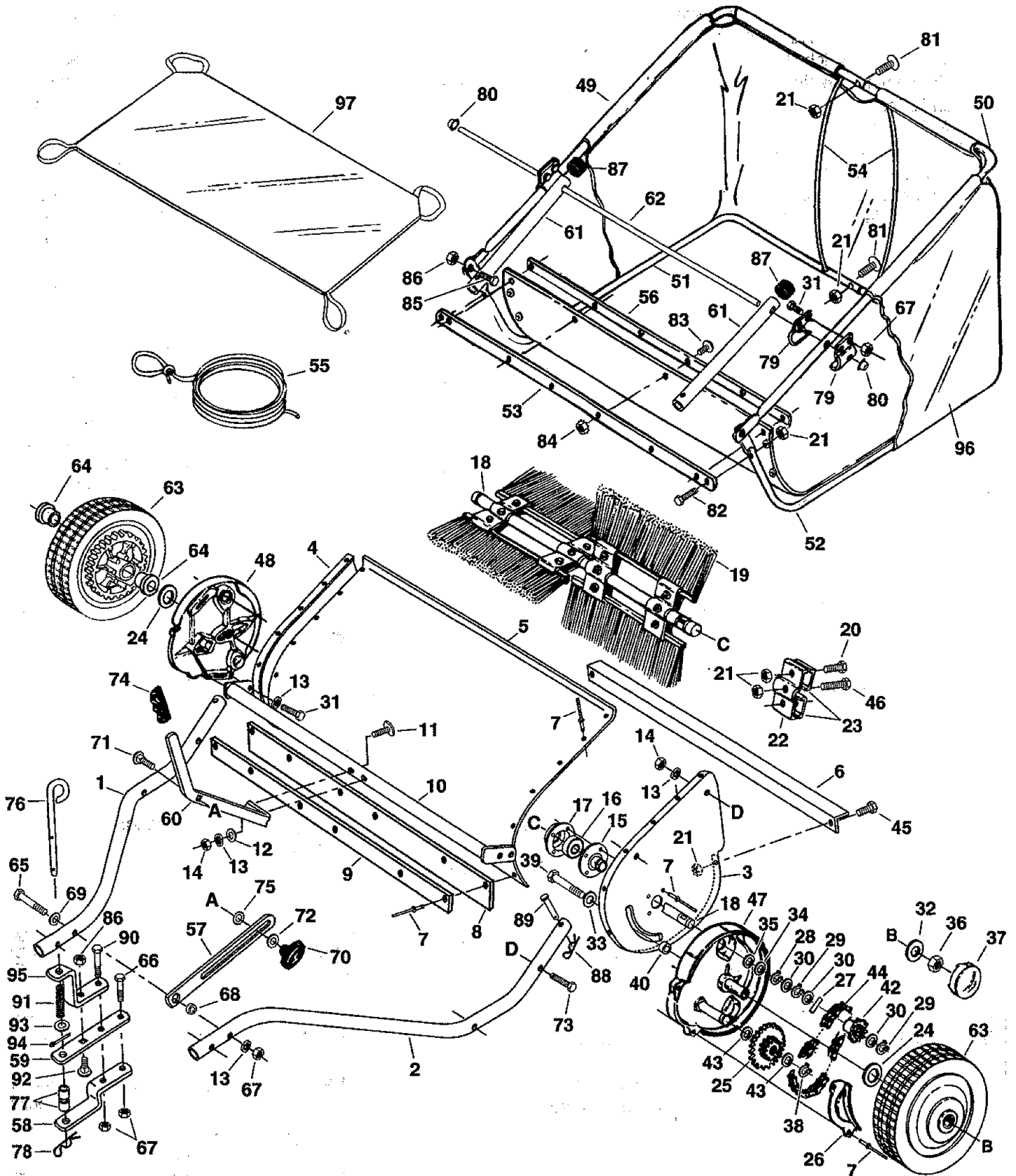

REPAIR PARTS LIST FOR MODEL 486.24211 - 42" HIGH PERFORMANCE LAWSWEEPER

| REF. NO. | PART NO. | QTY. | DESCRIPTION | REF. NO. | PART NO. | QTY. | DESCRIPTION |
|----------|----------|------|-------------------------------------|----------|-----------|------|-------------------------------------|
| 1 | 46776 | 1 | Hitch Tube, R.H. | 50 | 46735 | 1 | Tube, Upper Hopper Frame L.H. |
| 2 | 46777 | 1 | Hitch Tube, L.H. | 51 | 46732 | 1 | Tube, Lower Hopper Frame R.H. |
| 3 | 24195 | 1 | End Plate, L.H. | 52 | 46733 | 1 | Tube, Lower Hopper Frame L.H. |
| 4 | 24196 | 1 | End Plate, R.H. | 53 | 24189 | 1 | Strap, Bag Frame |
| 5 | 24184 | 1 | Wrapper | 54 | 43938 | 2 | Rod, Hopper Support 34" |
| 6 | 24185 | 1 | Brace, Rear Support | 55 | 43737 | 1 | Hopper Rope |
| 7 | C-9M5732 | 30 | Rivet, Pop | 56 | 24190 | 1 | Retainer, Bag |
| 8 | 46778 | 1 | Skirt, 42" | 57 | 24191 | 1 | Strap, Height Adjustment |
| 9 | 24186 | 1 | Retainer, Skirt | 58 | 23687 | 1 | Bracket, Hitch |
| 10 | 63468 | 1 | Height Adjustment Tube Ass'y. | 59 | 24192 | 1 | Bracket, Hitch (Straight) |
| 11 | 44947 | 2 | Bolt, Cvd. Hd. 5/16-18 x 1-5/8" Lg. | 60 | 24193 | 1 | Handle, Height Adjustment |
| 12 | 44695 | 2 | Washer, Bowed 1" x .32" x .06" | 61 | 46781 | 2 | Tube, Bag Arm |
| 13 | 43086 | 12 | Lock Washer, 5/16" | 62 | 46823 | 1 | Rod, Hopper Bag Pivot |
| 14 | 43083 | 6 | Nut, Hex 5/16-18 Thread | 63 | 44985 | 2 | Wheel & Tire Ass'y. (with bearings) |
| 15 | 62489 | 2 | Brush Bushing Ass'y. | 64 | 45088 | 4 | Wheel Bearing |
| 16 | 44232 | 2 | Ball Bearing | 65 | 46782 | 2 | Bolt, Hex 5/16-18 x 3" Lg. |
| 17 | 1629-56 | 2 | Retainer, Dust Cover | 66 | 43224 | 1 | Bolt, Hex 5/16-18 x 2-1/4" Lg. |
| 18 | 24198 | 1 | Brush Shaft | 67 | 43064 | 8 | Nut, Hex Lock 5/16-18 Thread |
| 19 | 46780 | 4 | Brush, 42" | 68 | 46847 | 1 | Bushing, Spacer |
| 20 | 43012 | 8 | Bolt, Hex 1/4-20 x 3/4" Lg. | 69 | R19111116 | 2 | Washer, Flat (5/16) 11/32" x 11/16" |
| 21 | 43013 | 18 | Nut, Hex Lock 1/4-20 Thread | 70 | 43720 | 1 | Knob, Wing 5/16-18 Thread |
| 22 | 23580 | 4 | Retainer, Brush (Double) | 71 | 43080 | 1 | Bolt, Carriage 5/16-18 x 3/4" Lg. |
| 23 | 23581 | 8 | Retainer, Brush (Single) | 72 | 43081 | 1 | Washer, Flat 5/16" Std. Wrt. |
| 24 | 44008 | 2 | Washer, Flat 1-1/8" x .78" x .025" | 73 | 43084 | 4 | Bolt, Hex 5/16-18 x 1-3/4" Lg. |
| 25 | 62490 | 2 | Sprocket / Gear | 74 | 43943 | 1 | Grip, Height Adjust |
| 26 | 23573 | 2 | Dust Cover | 75 | 44732 | 1 | Washer, Tooth Lock 5/16" |
| 27 | 47046 | 2 | Dowel Pin (Drive) | 76 | 46816 | 1 | Pin, Hitch |
| 28 | 43655 | 2 | Ring, Retaining 3/4" | 77 | 23368 | 2 | Tube, Hitch Spacer |
| 29 | 1650-21 | 4 | Ring, Retaining .594" | 78 | 43343 | 1 | Hairpin Cotter, 1/8" #4 |
| 30 | 44007 | 6 | Washer, Shim 1-1/8" x .594" x .025" | 79 | 23331 | 4 | Clamp, Hopper Mount |
| 31 | 43182 | 8 | Bolt, Hex 5/16-18 x 3/4" Lg. | 80 | 44917 | 2 | Palnut, 3/8" |
| 32 | 141 | 2 | Washer, Flat 1-1/2" x .375" x .062" | 81 | 43978 | 2 | Bolt, Cvd. Hd. 1/4-20 x 1" Lg. |
| 33 | 43070 | 2 | Washer, 3/8" Std. Wrt. | 82 | 1509-90 | 2 | Bolt, Hex 1/4-20 x 1-1/4" Lg. |
| 34 | 1540-31 | 2 | Washer, Flat .78" x 1.25" x .06" | 83 | 43346 | 6 | Bolt, Sl. Tr. Hd. #10-32 x 5/8" Lg. |
| 35 | 1540-107 | 2 | Washer, Flat .78" x 1.25" x .031" | 84 | 43662 | 6 | Nut, Hex Lock #10-32 SEMS |
| 36 | 1038 | 2 | Nut, Hex Lock 3/8-24 Thread | 85 | 43407 | 2 | Bolt, Hex 3/8-16 x 3/4" Lg. |
| 37 | 2674-32 | 2 | Hub Cap | 86 | 43082 | 3 | Nut, Hex Lock 3/8-16 Thread |
| 38 | 43894 | 2 | Ring, Retaining 1/2" | 87 | 44481 | 2 | Cap, Vinyl |
| 39 | 43932 | 2 | Bolt, Hex 3/8-24 x 3-1/2" Lg. | 88 | 43055 | 2 | Hairpin Cotter, 3/32" #3 |
| 40 | 23400 | 2 | Bushing, Spacer | 89 | 46867 | 2 | Pin, Clevis 1/4" x 1-1/2" Lg. |
| 41 | 43890 | 1 | Sprocket, Ratchet R.H. (not shown) | 90 | 44292 | 1 | Bolt, Hex 5/16-18 x 2-1/2" Lg. |
| 42 | 43889 | 1 | Sprocket, Ratchet L.H. | 91 | 44230 | 1 | Spring, Hitch Pin |
| 43 | 44137 | 4 | Washer, 1/2" x 1" x .02" | 92 | 43350 | 1 | Bolt, Carr. 3/8-16 x 1" Lg. |
| 44 | 44542 | 2 | Chain, Roller | 93 | 43070 | 1 | Washer, 3/8" Std. Wrt. |
| 45 | 43175 | 2 | Bolt, Hex 1/4-20 x 1/2" Lg. | 94 | 142 | 1 | Pin, Cotter 1/8" x 3/4" Lg. |
| 46 | 43661 | 4 | Bolt, Hex 1/4-20 x 1" Lg. | 95 | 23684 | 1 | Bracket, Hitch Pin |
| 47 | 62791 | 1 | Housing, Wheel Drive Ass'y. L.H. | 96 | 46819 | 1 | Hopper Bag |
| 48 | 62792 | 1 | Housing, Wheel Drive Ass'y. R.H. | 97 | 46739 | 1 | Wind Screen |
| 49 | 46734 | 1 | Tube, Upper Hopper Frame R.H. | | 46821 | 1 | Owners Manual |

Get it fixed, at your home or ours!

For repair of major brand appliances **in your own home...**
no matter who made it, no matter who sold it!

1-800-4-MY-HOMESM Anytime, day or night
(1-800-469-4663)

www.sears.com

To bring in products such as vacuums, lawn equipment and electronics
for repair, call for the location of your nearest **Sears Parts & Repair Center.**

1-800-488-1222 Anytime, day or night

www.sears.com

For the replacement parts, accessories and owner's manuals
that you need to do-it-yourself, call **Sears PartsDirectSM!**

1-800-366-PART 6 a.m. – 11 p.m. CST,
(1-800-366-7278) 7 days a week

www.sears.com/partsdirect

To purchase or inquire about a Sears Service Agreement:

1-800-827-6655

7 a.m. – 5 p.m. CST, Mon. – Sat.

Para pedir servicio de reparación a domicilio,
y para ordenar piezas con entrega a domicilio:

1-888-SU-HOGARSM
(1-888-784-6427)

Au Canada pour service en français:

1-877-LE-FOYERSM
(1-877-533-6937)

SEARS
HomeCentralSM