

Sunbeam

Planetary Mixmaster®

Bench Mixer

Instruction Booklet
MX7900

Please read these instructions carefully
and retain for future reference.



Contents

Sunbeam's Safety Precautions	2
Features of your Planetary Mixmaster®	3
Using your Planetary Mixmaster®	5
Safety Mechanisms	8
Mixing Guide	9
Oven Temperature Guide	10
Care and Cleaning	11
Troubleshooting Guide	12
Making a Successful Dough	13
Recipes	16

Important instructions – retain for future use.

تأكد من تفهم احتياطات السلامة المذكورة اعلاه

請務必理解上述的安全預防措施。

Assurez-vous que les précautions ci-dessus relatives à la sécurité sont bien comprises

Versichern Sie sich, dass die obenstehenden Sicherheitsmaßnahmen Verstanden werden

Βεβαιώστε πως οι παραπάνω προφυλάξεις ασφαλείας γίνονται κατανοητές

Pastikan bahwa tindakan-tindakan keselamatan seperti di atas dimengerti anda

Accertatevi che le suddette norme di sicurezza siano comprese a dovere

上記の注意事項をよくお読みになり、安全を御確認ください

Уверете се дека погоре споменатите мерки на претпазливост се добро разбрани

Asegúrese de que las precauciones de seguridad precedentes sean bien comprendidas

کاری بکنید کہ احتیاطهای بالا حتماً درک بشوند

ต้องแน่ใจว่า ข้อควรระวังเรื่องความปลอดภัยข้างต้น เป็นที่เข้าใจกันดี

Yukarda belirtilen güvenlik önlemlerinin anlaşıldığından emin olunuz

Xin kiểm chắc rằng những biện pháp làm an toàn kể trên được hiểu rõ

Sunbeam's Safety Precautions

SAFETY PRECAUTIONS FOR YOUR SUNBEAM PLANETARY MIXMASTER® BENCH MIXER.

- Never remove Scrapemaster™ beater, whisk or dough hook when the appliance is in operation.
- Ensure fingers are kept well away from moving Scrapemaster™ beater, whisk or dough hook.
- Ensure that the bowl is secured and locked onto the base of the Planetary Mixmaster® Bench Mixer before commencing mixing.
- Do not unlock or remove the mixing bowl from the base of the Planetary Mixmaster® Bench Mixer

whilst in use.

- Never tilt back the head of the Planetary Mixmaster® Bench Mixer whilst the appliance is in operation.
- When using extremely heavy loads the appliance should not be operated for more than 3 minutes. This does not apply to the recipes detailed in this booklet.
- Ensure long hair is tied back and young children are not near the bowl.

Sunbeam are very safety conscious when designing and manufacturing consumer products, but it is essential that the product user also exercise care when using an electrical appliance. Listed below are precautions which are essential for the safe use of an electrical appliance:

- Read carefully and save all the instructions provided with an appliance.
- Always turn the power off at the power outlet before you insert or remove a plug. Remove by grasping the plug - do not pull on the cord.
- Turn the power off and remove the plug when the appliance is not in use and before cleaning.
- Do not use your appliance with an extension cord unless this cord has been checked and tested by a qualified technician or service person.
- Always use your appliance from a power outlet of the voltage (A.C. only) marked on the appliance.
- This appliance is not intended for use by young children or infirm persons unless they have been adequately supervised by a responsible adult to ensure that they can use the appliance safely.
- Young children should be supervised to ensure that they do not play with the appliance.
- Never leave an appliance unattended while in use.

- Do not use an appliance for any purpose other than its intended use.
- Do not place an appliance on or near a hot gas flame, electric element or on a heated oven. Do not place on top of any other appliance.
- Do not let the power cord of an appliance hang over the edge of a table or bench top or touch any hot surface.
- Do not operate any electrical appliance with a damaged cord or after the appliance has been damaged in any manner. If damage is suspected, return the appliance to the nearest Sunbeam Appointed Service Centre for examination, repair or adjustment.
- For additional protection, Sunbeam recommend the use of a residual current device (RCD) with a tripping current not exceeding 30mA in the electrical circuit supplying power to your appliances.
- Do not immerse the appliance in water or any other liquid unless recommended.
- This appliance is intended to be used in household and similar applications such as: staff kitchen areas in shops, offices and other working environments; farm houses; by clients in hotels, motels and other residential type environments; bed and breakfast type environments.

If you have any concerns regarding the performance and use of your appliance, please visit www.sunbeam.com.au or contact the Sunbeam Consumer Service Line.

Ensure the above safety precautions are understood.

Features of your Planetary Mixmaster[®] Bench Mixer

800W motor

Powerful motor achieves thorough mixing results.

Planetary mixing action

Enables the mixing attachment (Scrapemaster™ spatula beater, whisk or dough hook) to rotate whilst travelling around the inside of the bowl, and reach all areas of the bowl ensuring ingredients are completely mixed.

Stainless steel mixing bowl

The 4.5L litre mixing bowl is ideal for mixing large or small quantities of ingredients. It features a handle for ease of use.

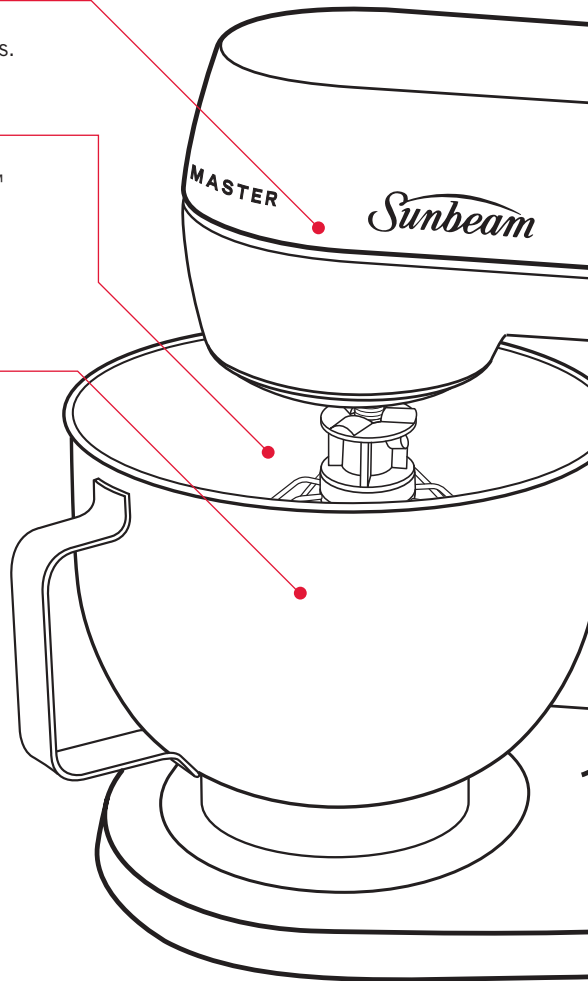

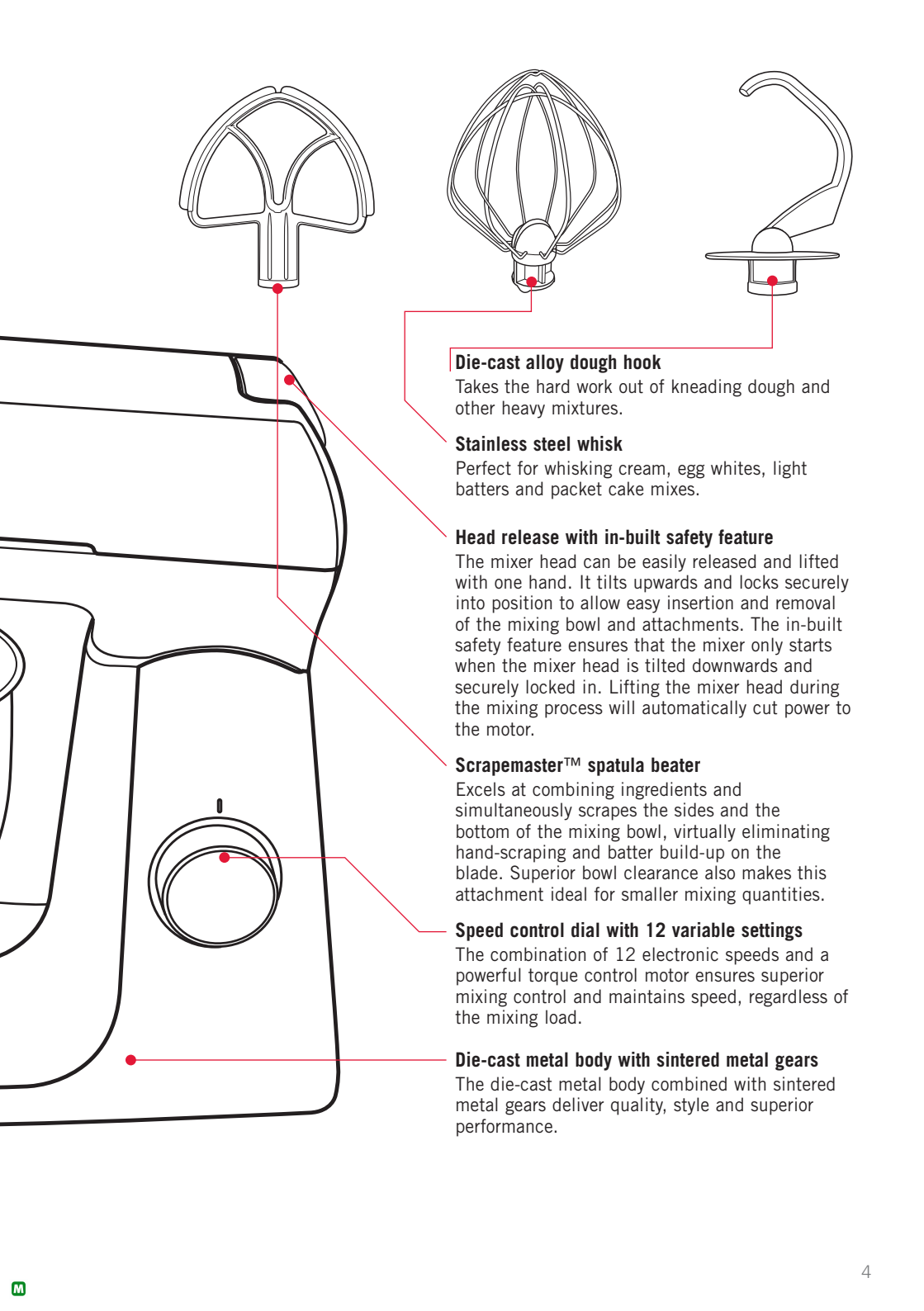

Die-cast alloy dough hook

Takes the hard work out of kneading dough and other heavy mixtures.

Stainless steel whisk

Perfect for whisking cream, egg whites, light batters and packet cake mixes.

Head release with in-built safety feature

The mixer head can be easily released and lifted with one hand. It tilts upwards and locks securely into position to allow easy insertion and removal of the mixing bowl and attachments. The in-built safety feature ensures that the mixer only starts when the mixer head is tilted downwards and securely locked in. Lifting the mixer head during the mixing process will automatically cut power to the motor.

Scrapemaster™ spatula beater

Excels at combining ingredients and simultaneously scrapes the sides and the bottom of the mixing bowl, virtually eliminating hand-scraping and batter build-up on the blade. Superior bowl clearance also makes this attachment ideal for smaller mixing quantities.

Speed control dial with 12 variable settings

The combination of 12 electronic speeds and a powerful torque control motor ensures superior mixing control and maintains speed, regardless of the mixing load.

Die-cast metal body with sintered metal gears

The die-cast metal body combined with sintered metal gears deliver quality, style and superior performance.

Using your Planetary Mixmaster® Bench Mixer

Before using your Planetary Mixmaster® Bench Mixer

Before using your Planetary Mixmaster® Bench Mixer for the first time, remove any packaging material and promotional labels or tags. Please also remove the plastic plug pin cover before using the mixer. It is recommended to wash the mixing bowl, Scrapemaster™ spatula beater, whisk and dough hook in warm soapy water with a soft cloth. Rinse and dry thoroughly.

Set-up

Before assembling your Planetary Mixmaster® Bench Mixer, be sure the power cord is unplugged from the power outlet. Position the mixer on a level, dry surface such as a bench top.

1. Press the 'head release' button, located at the rear of the mixer head. This will release the mixer head out of its locked position. Ease the mixer head backwards until it locks into its tilt position (Fig. 1).

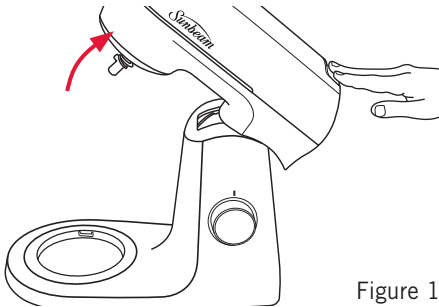

Figure 1

2. Select the desired attachment depending on the mixing task to be performed:



– Scrapemaster™ spatula beater for smaller amounts of mixture or creaming butter and sugar heavy cake mixes. Also great for folding ingredients



– Whisk for whisking cream, egg whites, light batters and packet cake mixes.



– Dough hook for kneading dough and other heavy mixtures.

3. Attach the selected mixing attachment onto the mixing shaft, aligning the groove in the top of the attachment such that it keys into the locking pin on the shaft. Push the attachment upwards over the locking pin and turn clockwise until securely locked in. (Fig 2).

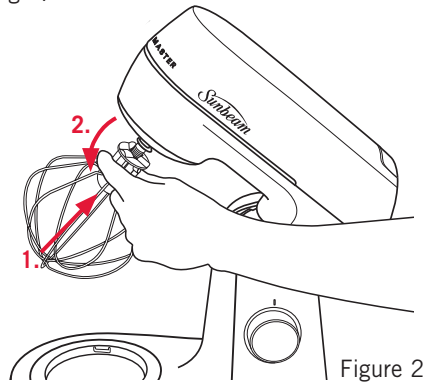

Figure 2

Note: Be sure the attachment is locked firmly in place.

Using your Planetary Mixmaster® Bench Mixer continued

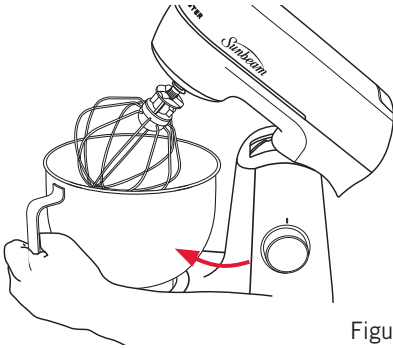

Figure 3

4. Place the bowl on the base with the handle facing you. Then gently rotate the bowl in a clockwise direction until it locks into position (Fig 3). The bowl should feel firm with no movement.

5. Press the 'head release' button to un-lock it from its position and ease the mixer head down (Fig. 4).



Figure 4

Using your Planetary Mixmaster® Bench Mixer

1. Position the mixer on a level, dry surface such as a bench top. Ensure the mixing bowl is in place and the desired attachment is inserted.
2. Plug the power cord into a 230/240 Volt AC power outlet.
3. Release the mixer head out of its locked position and ease it backwards and upwards until it locks into its tilt position. Add ingredients to the mixing bowl. (Fig. 1, page 5)
Then, un-lock the mixer head and lower it forward into the mixing bowl. (Fig. 4)
4. Turn the speed control dial clockwise to commence mixing (Fig. 5).



Figure 5

Using your Planetary Mixmaster® Bench Mixer continued

6. When mixing is complete, turn the speed control dial anti-clockwise to the '0' position (Fig. 6) and unplug the cord from the power outlet.



Figure 6

7. Press the 'head release' button and ease the mixer head back until it is locked into the tilt back position (see Fig. 1. page 5).
8. To remove the particular mixing attachment, push it upwards, turn it anti-clockwise, then pull it downwards (Fig. 7).

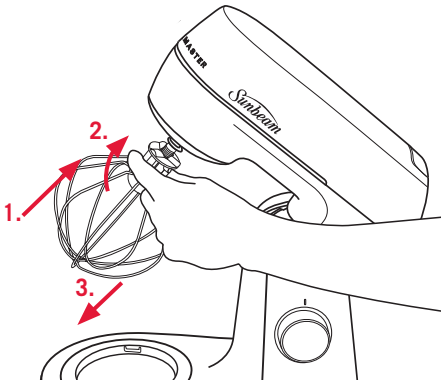

Figure 7

Safety Mechanisms

Thermo cut-off – temperature overload

The mixer is equipped with a self-resetting safety device which safeguards against overheating the motor with excessive loads. If overheating occurs, the mixer will automatically activate the overheating protection device and switch itself off. The mixer will beep and the screen will flash continuously. Switch the mixer off and unplug it from the power point. Release the mixer head and tilt it back until it is locked into the tilt back position. Let the mixer rest for 30 min.

Electronic protection cut-out

If the mixing load is too heavy for the selected speed and prevents the attachment from rotating, the mixer will cut-out to prevent damage to the unit. Unplug the mixer and remove some of the mixture from the bowl, working in batches.

Mixer head safety mechanism

The mixer head must be locked down or the motor will not operate. If the mixer head is tilted upwards during operation, the mixer will automatically stop. This is a safety mechanism to avoid injury.

Mixing Guide

Please keep in mind that the various mixing tasks and related speeds, listed in the table below, may vary slightly from recipe to recipe. Please refer to it regularly as you develop your understanding of how different ingredients interact when mixing.

SPEED SETTING RANGE	MIXING TASK
LOW 1-4	FOLDING & KNEADING Combining or initial mixing of ingredients Folding Kneading – doughs (pastry, bread, scones, etc.)
MEDIUM 5-7	LIGHT MIXING Kneading – heavy doughs Beating – sugar and butter, cake mixes
HIGH 8-10	CREAMING & BEATING Whisking – light batters Beating – heavy batters/icing
VERY HIGH 11-12	WHIPPING & AERATING Whisking – egg whites/cream

NOTES:

For most recipes, it is better to begin your mixing on a slower speed until the ingredients begin combining, then move to the appropriate speed range for the particular task.

Generally, there is not one set speed for an entire recipe. You will need to change the speed of the mixer depending on what stage of the recipe you are working on. This is communicated in the recipe section.

When mixing larger quantities you may need to increase the mixer speed due to the amount of mixing required and the larger load on the machine.

When building up a recipe that requires the addition of dry ingredients, such as flour, slow the speed down whilst these ingredients are being added to avoid a snow storm effect. Once the additional ingredients begin combining then slowly increase to the appropriate speed for the particular mixing task.

Oven Temperature Guide

For your information, the following temperature settings are included as a guide.

DESCRIPTION OF OVEN TEMPERATURES	Degrees Celcius °C	Degrees Farenheit °F	Gas Mark
Very Slow	120	250	½
Slow	140-150	300	1-2
Moderately Slow	160	325	3
Moderate	180	350	4
Moderately hot	200	400	6
Hot	220	425	8
Very Hot	240	475	9

Note: If using fan forced ovens be sure to turn the temperature down by 20°C.
Also check recipes at the back of this booklet.

Care and Cleaning

Before cleaning your Sunbeam Planetary Mixmaster®, ensure that the power is turned off at the power outlet, then remove the plug. Wipe over the outside area of the Planetary Mixmaster® including the head and base, with a dampened cloth and polish with a soft dry cloth.

Wipe any excess food particles from the power cord.

Sunbeam recommends to wash the mixing bowl, Scrapemaster™ spatula beater, whisk and dough hook in warm soapy water and wipe dry – use a brush if necessary to remove any sticky food particles.

All plastic components deteriorate through prolonged dishwasher use. However, parts of your Planetary Mixmaster® are tolerant to dishwasher use. These include the stainless steel mixing bowl, Scrapemaster™ spatula beater, whisk and dough hook.

Note: Place only on the top rack of the dishwasher.

Stainless steel whisk

After washing the stainless steel whisk, the outer wire may have moved out of position and become misaligned (see Figure 8). Please clip the outer wire back into position (see Figure 9).

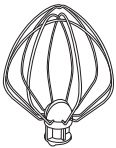

Figure 8

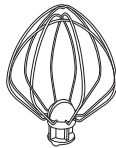

Figure 9

Maintenance Service

Your Sunbeam Planetary Mixmaster® should be regularly checked. After approximately four years of domestic use, the grease in the gear compartment should be examined. We suggest at that time you send the mixer to your nearest Sunbeam Appliance Service Centre to ensure efficient, correct servicing.

Storage

Keep your Sunbeam Planetary Mixmaster® Bench Mixer in a convenient position on your kitchen bench ready for use at all times. Place the Scrapemaster™ spatula beater, whisk and dough hook in the mixing bowl as storage of these attachments in a drawer with other kitchen equipment may cause damage.

Note: Never wind the power cord around the mixer after use as the warmth from the motor may cause damage to the power cord. For added convenience the unused cord length can easily be pushed into the base of the mixer for storage.

Troubleshooting Guide

Problem	Possible Cause	What to do
Motor will not start.	Motor is over-heated. Mixer head is not locked down properly.	Unplug and allow motor to cool, (the mixer head should be cool to touch). Move mixture in mixing bowl to the side of the attachment, to allow the attachment to go all the way into the bowl.
Motor is over-heated.	Use of a high speed for a long time. Mixture too heavy. Mixing quantity too large.	Unplug and allow motor to cool, (the mixer head should be cool to touch). Try mixing in batches.
Mixer head does not lock down properly.	Thick mixture is preventing the attachment from going all the way down into the bowl.	Move mixture in mixing bowl to the side of the attachment, to allow the attachment to go all the way into the bowl.
Attachment is hitting the bowl.	Attachment is not inserted correctly. Mixing bowl is not locked into the base properly.	Remove the attachment and try inserting again. Refer to the instructions in this booklet if needed. Lock bowl into position. Refer to the instructions in this booklet if needed.
Mixer is moving on the benchtop.	Chosen speed is too high for the mixture. Mixture caught up in the attachment. Flour or spills on bench top.	Lower the speed or mix in batches. Scrape down the attachment and continue mixing. Clean and dry benchtop as well as the mixer base.

Making a Successful Dough

Measuring Ingredients

Careful and correct measurement of all ingredients is essential for recipe success (particularly when baking). Australian Standard Metric cup and spoon measures are used in all recipes in the book. All cup and spoon measurements should be level.

- One metric tablespoon is equal to 20mls.
- One metric teaspoon is equal to 5mls.
- One liquid cup measurement is equal to 250mls.
- All eggs used in our recipes are extra large (59g) eggs, unless otherwise specified.

The following are some hints on measuring ingredients.

When measuring wet ingredients, always use a measuring jug or if measuring small quantities, use a standard metric measuring spoon. Place the measuring jug on a level surface and check the measurement at eye level.

When measuring dry ingredients, always use a standard metric measuring cup or standard metric measuring spoon. Shake gently to ensure there are no air pockets and level the surface with a knife or metal spatula. Never tap the cup on the bench or pack in the ingredients (unless specified); this will give an inaccurate measurement.

Note: crush any lumps, particularly in bicarbonate of soda or sugar before measuring.

When measuring other ingredients, always weigh in grams using metric scales. To ensure an accurate reading, always remember to “tare” the scales back to zero with the empty container before adding any food.

Tips for substituting Ingredients

- Unsalted butter is best for cake baking, however it can be substituted with salted butter or margarine if necessary. Margarine may slightly alter the texture of the final result.
- Self raising flour = plain flour + baking powder (1 cup self raising flour = 1 cup plain flour + 2 teaspoons baking powder)
- 1 cup plain flour + 1 teaspoon baking powder = $\frac{1}{2}$ cup plain flour + $\frac{1}{2}$ cup self raising flour
- When substituting wheat flour with gluten free flour, the best results are usually achieved in recipes that have a small amount of flour.
- Commercial baking powders can contain wheat starch. If you are allergic to wheat, you can make your own. Baking powder = 1 teaspoon bicarbonate of soda + 2 teaspoons cream of tartar
- Icing sugar mixture can contain wheat starch (this prevents it going lumpy). If you have a gluten intolerance, pure icing sugar can be used instead.
- Sultanas can be substituted with equal measure of another dried fruit (best if they are chopped to size).
- Golden syrup can be substituted with equal measure of treacle or molasses
- 1 cup buttermilk = 1 cup fresh milk + 2 teaspoons vinegar or lemon juice.
- Milk can be substituted with soy milk. It can sometimes also be replaced with fruit juice acting as the liquid component.
- 7g dry yeast (1 sachet) = 15g compressed yeast

Making a Successful Dough continued

Preparing the dough

1. Insert dough hook (refer to page 6). Place the dry ingredients into the bowl and lock the bowl onto the base.
2. Turn the speed dial to low speed (1-4), and gradually add the liquid ingredients (including the pre-prepared yeast mixture) to the bowl. When the ingredients start to form a ball, stop the mixer and use a rubber or plastic spatula to scrape down the sides of the bowl if necessary.
3. Knead on low speed (1-4) (depending on the amount of dough) until smooth and elastic; for about 5-8 minutes.
4. Transfer dough to a large, well greased mixing bowl. Cover the bowl with a light cloth or plastic wrap and place it in a warm, draft-free area until the dough doubles in size.
5. Plunge fist into the centre of the risen dough to punch out excess air. Fold outer edges into the centre and turn dough out onto a lightly floured surface. Cut and shape dough to form buns, rolls or freeform loaves and place on prepared baking trays. Alternatively, place dough into prepared bread tins. For pizza dough, it is now ready to be rolled, topped and baked.
6. For the final rising of the bread dough, cover the shaped dough with a light cloth and place in a warm, draft-free area until doubled in size again. Glaze and bake.

Tips

To add interest to breads.

- Brush dough with a little milk and sprinkle loaves or buns with poppy, caraway or sesame seeds before baking.
- Sprinkle loaves with shredded cheese during the last few minutes of baking.
- Drizzle cooled, sweet tea rings or buns with icing, or dust with icing sugar before serving.

Glazes

Glazes may be brushed over the dough before, during or after baking.

For a shiny crust, brush with cream or evaporated milk before baking; or with warm sieved apricot jam after baking.

For a glossy crust, brush with beaten egg white before baking.

For a matt finish, brush with melted butter or margarine after baking.

Making a Successful Dough continued

Questions & Answers:

Q. My mixture seems a little dry and crumbly.

Do I need to add more water?

A. Some flour tends to absorb or want more moisture/liquid, especially on warm or humid days. Add more water, a drop at a time, until a smooth ball/dough is reached.

Q. I added too much water and my dough is very sticky, what can I do?

A. If the dough is smooth without lumps, add a little flour at a time and knead the dough until it is smooth, soft to the touch and bounces back when pressed with the tip of your finger. Dough should not be sticky to touch.

Q. My yeast did not bubble or foam, why?

A. The yeast may be dead or inactive, in which case you will need to replace it. This occurs when the liquid added or the standing position was too hot or too cold. It can also be because the yeast is out of date. If the yeast does not foam, your dough will not rise.

Q. My dough did not rise, why?

A. If the yeast fermented properly, you may just need to place the bowl in a warmer position. Covering the bowl with plastic wrap, and ensuring the area is draft free may help. In winter, your dough will take longer to rise.

Recipes

Choc-Hazelnut Pancakes

Makes: 8-10

4 cups plain flour

3 $\frac{3}{4}$ cups buttermilk

$\frac{3}{4}$ cup caster sugar

3 eggs

Butter, for frying

Hazelnut spread and roasted hazelnuts, to serve

1. Place the flour, buttermilk, sugar and eggs in the Stainless Steel Mixing Bowl. Using the whisk mix on low speed (1-4) until combined. Increase to medium speed (5-7) and mix until smooth.
2. Melt butter in a large frypan over medium heat. Spoon $\frac{1}{4}$ cup of batter into the pan and cook until bubbles begin to appear on the surface. Flip pancake and cook for a minute. Repeat with remaining batter.
3. Serve pancakes with hazelnut spread and roasted hazelnuts.

Honey, Cranberry and Pistachio Nougat

Makes: approximately 24 pieces

2 sheets edible rice paper

2 $\frac{1}{2}$ cups caster sugar

$\frac{1}{2}$ cup honey

$\frac{1}{3}$ cup water

500g liquid glucose

2 egg whites

1 $\frac{1}{2}$ cups pistachios, toasted

$\frac{1}{2}$ cup dried cranberries

1. Lightly grease a 20cm square cake pan. Line base of the pan with 1 sheet of rice paper, trimming to fit.
2. Combine sugar, honey, water and glucose in a medium saucepan. Stir over medium heat until sugar dissolves. Bring to boil, do not stir after this point. Using a candy thermometer cook until mixture reaches 140°C. Immediately remove from heat.
3. Place egg whites in the Stainless Steel Mixing Bowl. Using the whisk whip egg whites on very high speed (11-12) until stiff peaks form. Reduce to medium speed (5-7) and slowly add the sugar syrup in a thin, steady stream. Once all the sugar syrup has been added continue beating for a further minute. Add the pistachios and cranberries.
4. Quickly spoon into prepared pan. Top with the remaining sheet of rice paper and gently press to flatten.
5. Set aside to cool at room temperature for 6 hours or until set. Remove from pan and cut into small squares to serve.

TIP: A spoon dipped in hot water will help spread the nougat.

Recipes continued

Coconut Marshmallows

Makes: approximately 16 pieces

- 1 cup cold water
- 1/3 cup powdered gelatine
- 4 cups caster sugar
- 2 cups hot water
- 2 teaspoons lemon juice
- 2 cups shredded coconut, lightly toasted

1. Combine cold water and gelatine. Set aside.
2. Combine sugar and hot water in a medium saucepan over medium heat. Stir constantly until all sugar granules have dissolved. Bring to the boil. Add gelatine and simmer uncovered for 20 minutes. Cool to room temperature.
3. Transfer sugar mixture to the Stainless Steel Mixing Bowl. Add lemon juice. Using the whisk beat on low speed (1-4) gradually increasing to very high speed (12) over 15 minutes. Mixture should be very thick and hold its shape.
4. Rinse a 20cm x 30cm lamington pan with cold water, do not dry. Spread marshmallow mixture into pan. Sprinkle with enough coconut to cover the surface. Set aside to cool at room temperature for 3 hours or until set. Cut marshmallow into squares. Toss in coconut before serving.

Apple Tea Cake

Serves: 8-10

- 125g butter, room temperature
- 1/2 cup brown sugar
- 1 teaspoon vanilla extract
- 2 eggs
- 1 1/2 cups plain flour
- 1/3 cup milk
- 2 green apples, peeled, cored, thinly sliced
- 2 teaspoons raw sugar
- 1/2 teaspoon ground cinnamon
- 1/4 cup apricot jam, warmed

1. Preheat oven to 160C. Grease and line a 22cm spring form cake pan with baking paper.
2. Place butter, sugar and vanilla in the Stainless Steel Mixing Bowl. Using the scraper beater mix on medium speed (5-7) until light and creamy. Add eggs making sure to beat well after each addition.
3. Reduce to low speed (1-4) and add flour and milk, mixing until combined. Pour into prepared pan.
4. Arrange apples over cake batter. Sprinkle with raw sugar and cinnamon. Bake for 50 minutes. Remove from oven, brush with warm jam and bake for a further 10 minutes or until cooked when tested. Remove from pan. Place on wire rack to cool.

Recipes continued

Molten Dulce de Leche Cakes

Dulce de Leche is South American caramel that can be purchased in most large supermarkets.

Serves: 6

2 egg yolks

1 egg

1 ½ cups dulce de leche*

¼ cup plain flour

Vanilla ice-cream, to serve

1. Preheat oven to 220C. Grease and flour 6 x 1 cup ramekins. Place on baking tray.
2. Place egg yolks and egg in the Stainless Steel Mixing Bowl. Using the whisk whip on very high speed (11-12) until light and pale.
3. Reduce to medium speed (5-7). Add dulce de leche whisking until combined. Fold through flour.
4. Divide mixture evenly between ramekins. Bake for 10-12 minutes or until golden but jiggle when shaken. Run knife around edge of ramekin and invert onto plate or bowl. Serve warm with vanilla ice-cream.

* Can be substituted for caramel condensed milk.

Pear and Chocolate Cake

Serves: 8-10

150g butter, chopped

150g dark chocolate, chopped

5 eggs, separated

1 cup caster sugar

⅓ cup crème fraîche

½ cup almond meal

¾ cup cocoa powder

400g can pears in syrup, drained, rinsed

1. Preheat oven to 180C. Grease and line a 23cm spring form cake pan with baking paper.
2. Place a large heatproof bowl over a saucepan of simmering water. Melt butter and chocolate until smooth.
3. Place egg whites in the Stainless Steel Mixing Bowl. Using the whisk whip egg whites on very high speed (11-12) until stiff peaks form. Set aside.
4. Place egg yolks in the Stainless Steel Mixing Bowl. Using the whisk whip egg yolks and sugar on very high speed (11-12) until light and pale.
5. Reduce to high speed (8-10) and slowly add chocolate mixture and crème fraîche. Sift over almond meal and cocoa powder, mixing on low speed (1-4) until just combined.
6. Fold through egg whites in three batches. Gently pour into prepared pan. Arrange pears over mixture. Bake for 40 minutes or until firm and cooked when tested. Allow to cool in pan for 10 minutes. Place on wire rack to cool.

Recipes continued

White Chocolate Layered Butter Cake

Serves: 8-10

185g butter, room temperature

1 $\frac{3}{4}$ cups caster sugar

1 $\frac{1}{2}$ teaspoons vanilla extract

4 eggs

1 $\frac{1}{2}$ cups plain flour

$\frac{3}{4}$ cup self-rising flour

$\frac{3}{4}$ cup milk

$\frac{3}{4}$ teaspoon baking soda

1. Preheat oven to 160°C. Grease and line a 23cm cake pan with baking paper.
2. Place butter, sugar and vanilla in the Stainless Steel Mixing Bowl. Using the scraper beater beat on medium speed (5-7) until light and creamy. Add eggs one at a time, making sure to beat well after each addition.
3. Add flours, milk and baking soda. Mix on low speed (1-2) until just combined.
4. Pour into prepared pan. Bake for about 1 $\frac{1}{2}$ hours or until cooked when tested. Stand in pan for 5 minutes. Place on wire rack to cool.
5. When cool, split cake horizontally into 3 even sized disks. Layer and cover with white chocolate ganache.

White Chocolate Ganache

Makes: 2 $\frac{1}{2}$ cups

1 cup thickened cream

600g white chocolate, chopped

1. Bring cream to boil in a medium saucepan and immediately remove from heat.
2. Place chocolate in cream. Stir until smooth. Cover and refrigerate, stirring occasionally until spreadable consistency.

Recipes continued

Chocolate Chocoholic Cake

Serves: 10-12

185g butter, room temperature

2 ¼ cups caster sugar

1 ½ cups water

¼ cup cocoa powder

¾ teaspoon baking soda

2 ¼ cups self-rising flour

3 eggs

1. Preheat oven to 180°C. Grease and line a 22cm cake pan with baking paper.
2. Combine butter, sugar, water, cocoa and baking soda in a large saucepan. Stir over medium heat without boiling until sugar has dissolved and butter is melted. Bring to boil then reduce heat to low. Simmer uncovered for 4 minutes. Allow to cool.
3. Pour sugar mixture and flour into the Stainless Steel Mixing Bowl. Using the scraper beater beat on low speed (1-4) until combined.
4. Increase to medium speed (5-7). Add eggs one at a time, making sure to beat well between after addition.
5. Pour into prepared pan. Bake for about 1 hour or until cooked when tested. Stand in pan for 5 minutes. Place on wire rack to cool. Top with rich fudge frosting.

Rich Fudge Frosting

Makes: 2 cups

180g butter, chopped

1 cup caster sugar

⅔ cup water

3 cups icing sugar

½ cup cocoa powder

1. Combine butter, sugar and water in a small saucepan. Stir over low heat, without boiling, until sugar dissolves.
2. Place icing sugar and cocoa powder in the Stainless Steel Mixing Bowl. Using the scraper beater on low speed (1-4) mix until combined. Add butter mixture and mix until smooth.
3. Cover and refrigerate for 20 minutes or until frosting is cool and thickens. Beat with a wooden spoon until spreadable.

Recipes continued

Almond Meringue Cake with Mascarpone Cream

Serves: 6-8

6 egg whites

1 ½ cups caster sugar

½ cup almond meal

250g tub mascarpone cream

220g dark chocolate, melted

1. Preheat oven to 160C. Line 3 baking trays with baking paper and draw a 20cm circle on each piece of baking paper.
2. Place egg whites in the Stainless Steel Mixing Bowl. Using the whisk whip on very high speed(11-12) while gradually adding sugar until stiff peaks form. Add almond meal mixing until well combined.
3. Divide mixture into three batches and spread evenly over circles marked on baking paper. Bake for 40 minutes or until crisp. Allow to cool in oven.
4. Place mascarpone in the Stainless Steel Mixing Bowl. Using the scraper beater mix on medium speed (5-7) mix until smooth. Gradually add melted chocolate and mix until well combined.
5. Sandwich meringues together with chocolate mascarpone cream. Serve.

Sour Cream Lemon Cake

Serves: 10-12

250g butter, room temperature

2 ½ cups caster sugar

6 eggs

1 cup sour cream

¼ cup lemon juice

2 tablespoons lemon zest

3 cups plain flour

½ teaspoon baking powder

½ teaspoon salt

1. Preheat oven to 180C. Grease and line a 24cm cake pan with baking paper.
2. Place butter and sugar in the Stainless Steel Mixing Bowl. Using the scraper beater mix on medium speed (5-7) beat until light and creamy. Add eggs one at a time, making sure to beat well after each addition.
3. Reduce to low speed (1-4) add sour cream, lemon juice and zest. Sift over flour, baking powder and salt. Gently fold mixture until well combined.
4. Pour into prepared pan. Bake for 1 hour and 20 minutes or until cooked when tested. Allow cake to cool in the pan for 15 minutes. Place on wire rack to cool.
5. Once cake has cooled, cover with lemon buttercream icing.

Recipes continued

Lemon Buttercream Icing

Makes: 2 cups

250g butter, room temperature

4 cups icing sugar

2 tablespoons lemon juice

2 tablespoons lemon zest

½ teaspoon salt

1. Place butter and icing sugar in the Stainless Steel Mixing Bowl. Using the scraper beater mix on medium speed (5-7) gradually increasing to high speed (9-10). Mix until light and fluffy.
2. Add lemon juice, zest and salt. Mix until combined.

Sour Cherry Crumb Cake

Serves: 10-12

Topping:

80g butter, chopped

¾ cup plain flour

¼ cup brown sugar

¼ cup caster sugar

¼ teaspoon ground cinnamon

Cake:

160g butter, room temperature

¾ cup caster sugar

1 teaspoon vanilla extract

2 eggs

1 ½ cups plain flour

¼ cup buttermilk

1 teaspoon baking powder

700g jar poached cherries, drained

1. Preheat oven to 180C. Grease and line a 20cm square slice pan with baking paper.
2. Topping: In a large bowl combine butter, flour, sugars and cinnamon. Rub with fingers until a chunky crumb has formed. Set aside.
3. Cake: Place butter, sugar and vanilla in the Stainless Steel Mixing Bowl. Using the scraper beater on medium speed (5-7) mix until light and creamy. Add eggs one at a time, making sure to beat well after each addition.
4. Reduce to low speed (1-4). Add flour, buttermilk and baking powder. Continue to mix on low speed (1-4) until combined.
5. Pour into prepared pan. Cover with cherries. Sprinkle crumb mixture over top of cake. Bake for 1 hour or until cooked when tested. Place on wire rack to cool.

Recipes continued

Flourless Orange Syrup Cake

Serves: 8-10

3 small oranges

3 eggs

1 cup caster sugar

3 cups almond meal

1 teaspoon baking powder

Syrup:

$\frac{2}{3}$ cup caster sugar

$\frac{1}{2}$ cup orange juice

1 tablespoon orange zest

1. Preheat oven to 170C. Grease and line a 22cm spring form cake pan with baking paper.
2. Place oranges in a medium saucepan and cover with water. Place over medium heat and bring to a simmer until oranges are tender, about 30-40 minutes. Drain and allow to cool. Roughly chop oranges, discarding the seeds.
3. Using a food processor process oranges until smooth.
4. Place eggs and sugar in the Stainless Steel Mixing Bowl. Using the whisk whip on high speed (8-10) until eggs are pale and have doubled in size.
5. Add remaining ingredients to the bowl. Reduce to low speed (1-4) and whisk until just combined.
6. Pour into prepared pan. Bake for 1 hour or until cooked when tested. Place on wire rack to cool.
7. Syrup: Place sugar, juice and zest in a medium sauce pan and bring to a simmer. Stir constantly until sugar has dissolved and the syrup has thickened. Drizzle over cake. Serve.

Lemon Melting Moments

Makes: 12 approximately

250g butter, room temperature

$\frac{1}{2}$ cup icing sugar

1 teaspoon vanilla extract

2 cups plain flour

$\frac{1}{2}$ cup custard powder

2 teaspoons lemon zest

Filling:

80g butter, room temperature

1 $\frac{1}{4}$ cups icing sugar

1 tablespoon lemon zest

2 teaspoons lemon juice

1. Preheat oven to 160C. Grease and line 2 baking trays with baking paper.
2. Place butter, sugar and vanilla in the Stainless Steel Mixing Bowl. Using the scraper beater mix on medium speed (5-7) until light and creamy.
3. Add remaining ingredients. Reduce to low speed (1-4) mixing until well combined.
4. Roll mixture into tablespoon sized balls. Place on prepared trays and gently press down with a back of a fork. Bake for 15-20 minutes or until cooked. Place on wire rack to cool.
5. Filling: Place all ingredients in the Stainless Steel Mixing Bowl. Using the scraper beater on high speed (8-10) mix until light and fluffy.
6. Once the cookies are fully cooled sandwich together with icing. Serve.

Recipes continued

Easy Chocolate Cookies

Makes: 30 approximately

170g butter, room temperature

1 ¼ cups caster sugar

1 egg

1 ½ cups plain flour

¾ cup cocoa powder

1 ¼ teaspoons baking powder

250g dark chocolate chips

1 teaspoon salt

1. Preheat oven to 180C. Grease and line two baking trays with baking paper.
2. Place butter and sugar in the Stainless Steel Mixing Bowl. Using the scraper beater mix on medium speed (5-7) until light and creamy. Add egg and mix until well combined.
3. Sift flour, cocoa powder and baking powder into the bowl.
4. Reduce to low speed (1-4) and mix until ingredients are well combined. Stir through chocolate chips and salt.
5. Roll mixture into tablespoon sized balls. Place on prepared trays and gently press down. Bake for 12-15 minutes or until cooked. Place on wire rack to cool.

White Chocolate Caramel Cookies

Makes: 30 approximately

125g butter, room temperature

½ cup brown sugar

1 tablespoon golden syrup

1 tablespoon milk

2 cups plain flour

2 teaspoons baking powder

250g white chocolate chips



1. Preheat oven to 180C. Grease and line two baking trays with baking paper.
2. Place butter and sugar in the Stainless Steel Mixing Bowl. Using the scraper beater mix on medium speed (5-7) until light and creamy. Add golden syrup and milk mixing until combined.
3. Add remaining ingredients. Reduce to low speed (1-4) mixing until well combined.
4. Roll mixture into tablespoon sized balls. Place on prepared trays and gently press down with the back of a fork. Bake for 15 minutes or until cooked. Place on wire rack to cool.

Recipes continued

Golden Syrup Walnut Scrolls

Makes: 12 each

- 100g butter, chopped
- 2 ¼ cups self-rising flour
- 1 tablespoon caster sugar
- ⅔ cup milk
- 1 egg
- 1 cup walnuts, chopped
- ½ cup slivered almonds
- ⅓ cup brown sugar
- 1 teaspoon ground cinnamon
- ¼ cup golden syrup

1. Preheat oven to 200°C. Lightly grease a 19cm x 29cm slice pan.
2. Place flour, sugar and half  the butter in the Stainless Steel Mixing Bowl. Using the scraper beater on low speed (1-4) mix until well combined. Add milk and egg.
3. Using the dough hook knead on low speed (1-4) until a sticky dough has formed.
4. Turn dough out onto a floured work surface and roll into a 30 x 40cm rectangle.
5. Sprinkle with walnuts, almonds, brown sugar and cinnamon. Dot with remaining butter. Roll dough tightly lengthways to form a loaf  trim ends and cut into 12 pieces.
6. Place cut side down in prepared pan. Bake for 25 minutes or until cooked. Place on wire rack to cool. Drizzle with golden syrup. Serve.

Golden Syrup Walnut S

Serves: 6-8

- 200g pitted dates, chopped
 - ⅓ cup boiling water
 - 1 ½ teaspoons baking powder
 - 125g butter, room temperature
 - 1 cup brown sugar
 - 2 eggs
 - 1 ½ cups plain flour
 - ¼ cup milk
1. Preheat oven to 180°C. Grease and line a 20cm cake pan with baking paper.
 2. Place the dates, water and baking powder in a small bowl. Set aside for 10 minutes.
 3. Place butter and sugar in the Stainless Steel Mixing Bowl. Using the scraper beater on medium speed (5-7) mix until light and creamy. Add eggs one at a time, making sure to beat well after each addition.
 4. Add flour, milk and date mixture. Reduce to low speed (1-4) mixing until well combined.
 5. Pour into prepared pan. Bake for 40 minutes or until cooked when tested. Serve warm with toffee sauce.

Toffee Sauce

Makes: 2 ¼ cups

- 200g butter, chopped
 - 1 cup thickened cream
 - 1 cup firmly packed brown sugar
1. Place all ingredients in a small saucepan. Stir over medium heat until melted and combined. Simmer for 3 minutes. Pour over sticky date pudding.

TIP: This sauce is also great over vanilla ice-cream.

Recipes continued

Cheese Biscuits

Makes: 40 approximately

250g butter, room temperature

1 cup grated parmesan cheese

1 cup grated Swiss cheese

4 eggs

2 ½ cups plain flour

1 teaspoon cayenne pepper

1 tablespoon rock salt

1. Preheat oven to 180C. Grease and line two baking trays with baking paper.
2. Place butter and cheeses in the Stainless Steel Mixing Bowl. Using the scraper beater on medium speed (5-7) mix until well combined. Add eggs one at a time, making sure to beat well after each addition.
3. Reduce to low speed (1-4) .Add flour and cayenne pepper mixing until well combined.
4. Use a rolling pin; roll out dough until ½ cm thick. With a 4cm cutter cut dough and place onto prepared trays. Sprinkle with rock salt.
5. Bake for 10 minutes or until cooked. Place on wire rack to cool.

Corn Biscuits

Makes: 8 approximately

500g frozen corn kernels, defrosted

2 eggs

1 red chilli, finely chopped

1 red onion, finely chopped

¾ cup plain flour

2 tablespoons freshly chopped coriander leaves

1 teaspoon baking soda

Salt and freshly ground black pepper, to taste
Butter, for cooking

1. Place all ingredients in the Stainless Steel Mixing Bowl. Using the scraper beater on low speed (1-4) mix until just incorporated. Season to taste with salt and pepper.
2. Melt butter in a large frypan over medium heat. Add ¼ cup of batter to pan and cook for 2 minutes on each side or until cooked. Serve hot.

Recipes continued

Fetta and Spinach Scrolls

Makes: 12 each

- 2 cups self-raising flour
- 1 tablespoon caster sugar
- 50g butter, chopped
- $\frac{3}{4}$ cup milk
- 1 egg
- 250g frozen spinach, thawed
- 1 cup pizza cheese
- 100g feta cheese, crumbled

1. Preheat oven to 200°C. Lightly grease a 19cm x 29cm slice pan.
2. Place flour, sugar and half on the butter in the Stainless Steel Mixing Bowl. Using the scraper beater on low speed (1-4) mix until well combined. Add milk and egg.
3. Using the dough hook knead on low speed (1-4) until a sticky dough has formed.
4. Turn dough out onto a clean, floured work surface and roll into a 30 x 40cm rectangle.
5. Sprinkle with spinach and cheeses. Dot with remaining butter. Roll dough tightly lengthways to form a long. Trim ends and cut into 12 pieces.
6. Place cut side down in prepared pan. Bake for 25 minutes or until cooked when tested. Place on wire rack to cool.

Cheesy Garlic Bread

Makes: 1 loaf

- 1 $\frac{1}{4}$ cups warm water
- 1 tablespoon caster sugar
- 2 teaspoons dry yeast
- 3 $\frac{1}{2}$ cups plain flour
- 2 tablespoons olive oil
- 1 teaspoon salt
- 3 cloves garlic, crushed
- 30g butter, room temperature
- 1 cup grated cheddar cheese
- $\frac{1}{2}$ cup grated parmesan cheese

1. Lightly coat a baking tray with flour.
2. In a small bowl combine water, sugar and yeast. Set aside until mixture begins to foam.
3. Place flour, oil, salt and yeast mixture in the Stainless Steel Mixing Bowl. Using the dough hook on low speed (1-2) knead for 5 minutes or until dough is soft and silky.
4. Add garlic, butter and cheeses to the dough and knead on low speed (1-2) for 2 minutes.
5. Roll into a log. Place on prepared baking tray and cover. Place in a warm area for 40 minutes or until doubled in size.
6. Preheat oven to 180C. Bake dough for 30 minutes or until golden brown and cooked when tested. Place on wire rack to cool.

Recipes continued

Rosemary, Olive and Sea Salt Focaccia Bread

Makes: 2 loaves

- 1 cup warm water
 - 1 tablespoon caster sugar
 - 2 teaspoons dry yeast
 - 3 ½ cups plain flour
 - ½ cup olive oil
 - 2 teaspoons salt
 - ⅓ cup kalamata olives
 - 2 tablespoons fresh rosemary leaves
 - 1 tablespoon sea salt
1. In a small bowl combine water, sugar and yeast. Set aside until mixture begins to foam.
 2. Place flour, half of the olive oil, salt and yeast mixture in the Stainless Steel Mixing Bowl. Using the dough hook knead on low speed (1-2) for 2 minutes or until dough forms a ball. Continue to knead for a further 8 minutes.
 3. Place dough in a lightly greased bowl, cover. Place in a warm area for 40 minutes or until doubled in size.
 4. Preheat oven to 180C. Grease and line two baking trays with baking paper.
 5. Punch down dough. Cut dough in half. On a lightly floured surface roll dough into a 20cm circle. Place on prepared trays.
 6. Press finger tips into the dough to form indents. Pour over remaining oil and scatter with olives, rosemary and sea salt. Bake for 30 minutes or until golden and cooked when tested. Serve warm or cold.

Basic Pizza Dough

Makes: 2 large pizzas

- 1 ¼ cups warm water
 - 2 teaspoons dry yeast
 - 1 teaspoon caster sugar
 - 2 cups plain flour
 - 2 tablespoons olive oil
 - ½ teaspoon salt
1. Combine the water, yeast and sugar in a jug. Set aside until mixture begins to foam.
 2. Place flour, oil, salt and yeast mixture in the Stainless Steel Mixing Bowl. Using the dough hook knead on low speed (1-2) for 2 minutes or mixture forms a ball. Continue to knead on low speed (1-2) for a further 8 minutes.
 3. Place dough in a lightly greased bowl, cover. Place in a warm area for 40 minutes or until doubled in size.
 4. Punch down dough. Cut dough in half.
 5. Take one piece of dough and roll on a lightly floured surface into a rough round. Place on a lightly greased pizza tray and stretch the dough to fit the tray. Repeat with remaining dough. Cover; allow to stand for 20-30 minutes. Top as desired.
- TIP: if you prefer a thick pizza crust, use this dough quantity to make 1 pizza.

Recipes continued

Supreme Pizza

Makes: 2 large pizzas

1 quantity basic pizza dough

¼ cup pizza sauce

2 cups pizza cheese

¼ cup chopped fresh basil

¼ cup pitted kalamata olives

1 small red capsicum, thinly sliced

½ red onion, thinly sliced

100g button mushrooms, thinly sliced

100g shaved ham, torn

Salt and freshly ground black pepper, to taste

1. Prepare basic pizza dough according to recipe.
2. Preheat oven to 180C.
3. Spread pizza sauce over bases. Sprinkle with half of the cheese. Top with remaining ingredients and sprinkle with remaining cheese.
4. Cook pizza for about 15 minutes or until bases are golden and cheese has melted. Season to taste with salt and pepper. Serve.

12 Month Replacement Guarantee

In the unlikely event that this appliance develops any malfunction within 12 months of purchase (3 months commercial use) due to faulty materials or manufacture, we will replace it for you free of charge.

Should you experience any difficulties with your appliance, please phone our customer service line for advice on 1300 881 861 in Australia, or 0800 786 232 in New Zealand. Alternatively, you can send a written claim to Sunbeam at the address listed below. On receipt of your claim, Sunbeam will seek to resolve your difficulties or, if the appliance is defective, advise you on how to obtain a replacement or refund.

Your Sunbeam 12 Month Replacement Guarantee naturally does not cover misuse or negligent handling and normal wear and tear.

Similarly your 12 Month Replacement Guarantee does not cover freight or any other costs incurred in making a claim. Please retain your receipt as proof of purchase.

The benefits given to you by this guarantee are in addition to your other rights and remedies under any laws which relate to the appliance.

Our goods come with guarantees that cannot be excluded under the Australian Consumer Law and under the New Zealand Consumer Guarantees Act.

In Australia you are entitled to a replacement or refund for a major failure and for compensation for any other reasonably foreseeable loss or damage. You are also entitled to have the goods repaired or replaced if the goods fail to be of acceptable quality and the failure does not amount to a major failure.

Should your appliance require repair or service after the guarantee period, contact your nearest Sunbeam service centre.

For a complete list of Sunbeam's authorised service centres visit our website or call:

Australia

www.sunbeam.com.au

1300 881 861

Units 5 & 6, 13 Lord Street
Botany NSW 2019 Australia

New Zealand

www.sunbeam.co.nz

0800 786 232

26 Vestey Drive, Mt Wellington
Auckland, New Zealand

Need help with your appliance?

Contact our customer service team or visit our website for information and tips on getting the most from your appliance.

In Australia

Visit www.sunbeam.com.au

Or call 1300 881 861

In New Zealand

Visit www.sunbeam.co.nz

Or call 0800 786 232

 is a registered trademark.

'Mixmaster' is a registered trademark of Sunbeam Corporation.

Made in China.

Due to minor changes in design or otherwise, the product may differ from the one shown in this leaflet.

© Copyright. Sunbeam Corporation Limited 2011.

ABN 45 000 006 771

Units 5 & 6, 13 Lord Street
Botany NSW 2019 Australia

Unit 3, Building D
26 Vestey Drive
Mt Wellington Auckland
New Zealand

Sunbeam Corporation is a division of GUD Holdings Ltd.