

 **MAXX COLD**
X-series

Front Breathing Undercounter Refrigerator
Service, Installation and Care Manual



MXCR27U-FBHC

IMPORTANT INFORMATION
READ BEFORE USE
PLEASE SAVE THESE INSTRUCTIONS!

CONTENTS

RECEIVING & INSPECTING EQUIPMENT 2

SAFETY WARNINGS 3

INSTALLATION 5

OPERATION 6

MAINTENANCE 8

SPECIFICATIONS & PARTS LISTING 10

WIRING DIAGRAMS 11

All rights reserved. Reproduction without written permission is prohibited.

SERIAL NUMBER INFORMATION

The serial number of all self-contained refrigerators and freezers is located inside the unit on the left hand side near the top on the wall.

Always have the serial number of your unit available when calling for parts or service.

You must also have a copy of your proof of purchase receipt or invoice, if you did not fill out and submit your warranty information card.

Failure to have submitted this data or share a photo copy showing ownership and purchase of this appliance may void it’s warranty coverage. This manual covers standard units only.

RECEIVING AND INSPECTING THE EQUIPMENT

Even though most equipment is shipped crated, care should be taken during unloading so the equipment is not damaged while being moved into the building.

1. Visually inspect the exterior of the package and skid or container. Any damage should be noted and reported to the delivering carrier immediately.
2. If damaged, open and inspect the contents with the carrier.
3. In the event that the exterior is not damaged, yet upon opening, there is concealed damage to the equipment, notify the carrier. Notification should be made verbally as well as in written form.
4. Request an inspection by the shipping company of the damaged equipment. This should be done within 10 days from receipt of the equipment. Failure to file in a timely fashion will preclude any financial reimbursement due to any freight damage as well as a possibly voiding the warranty.
5. Be certain to check the compressor compartment housing and visually inspect the refrigeration package. Be sure lines are secure and base is still intact.
6. Freight carriers can supply the necessary damage forms upon request.
7. Retain all crating material until an inspection has been made or waived.
8. After any claim has been processed, be sure to dispose of the packing material in an appropriate manner that meets any local code requirements and regulations as well as those of the trash/disposal carrier.

COMMERCIAL REFRIGERATOR SAFETY

Your safety and the safety of others are very important.

We have provided many important safety messages in this manual and on your appliance. Always read and obey all safety messages.

Our product instructions will be uploaded on our company official website.



This is the Safety Alert Symbol. This symbol alerts you to potential hazards that can kill or injure you and others. All safety messages will follow the Safety Alert Symbol and either the words "DANGER", "WARNING" or "CAUTION".



Danger means that failure to heed this safety statement may result in severe personal injury or death.



Warning means that failure to heed this safety statement may result in extensive product damage, serious personal injury, or death.



Caution means that failure to heed this safety statement may result in minor or moderate personal injury, or property or equipment damage.

All safety messages will alert you to what the potential hazard is, tell you how to reduce the chance of injury or damage to the unit and surroundings to let you know what can happen if the instructions aren't followed.

If the supply cord is damaged, it must be replaced by the manufacturer, its service agent or similarly qualified persons in order to avoid a shock, short or fire hazard.

This appliance is not intended for use by persons (including children) with reduced physical, sensory or mental capabilities, or lack of experience and knowledge, unless they have been given supervision or instruction concerning use of the appliance by a person responsible for their safety.

This equipment is for intended for commercial use and has satisfied North America Food Service application standards regarding sanitizing safety and energy usage.

This appliance operation is quite basic with successful field application where teenagers and persons with reduced physical sensory or mental capabilities or lack of experience and knowledge have successfully stocked, cleaned and monitored the unit in operation once they have been given supervision or instruction concerning use of the appliance in a safe way and understand the hazards involved.

Keep the appliance and its cord out of reach of small children and when or if unit is removed from service and disposed of be sure to disconnect and remove the door.

Do not store explosive substances such as aerosol cans with a flammable propellant in or near this appliance.

The appliance insulation may have been blown with a flammable gas like C5H10 based upon regulations in force at the time the unit was manufactured. Disposal of the appliance must comply with all local and federal regulations.

The key for appliance electric box should be safe kept by qualified persons in order to avoid a hazard



WARNING: RISK OF FIRE DUE TO FLAMMABLE MATERIALS

WARNING: Keep ventilation openings, in the appliance enclosure or in the built-in structure, clear of obstruction.

WARNING: Do not use mechanical devices or other means to accelerate the defrosting process, other than those recommended by the manufacturer.

WARNING: Do not damage the refrigerant circuit.

WARNING: Do not use electrical appliances inside the food storage compartments of the appliance, unless they are of the type recommended by the manufacturer.

Handling, moving, and use of the refrigerator or freezer to avoid either damaging the refrigerant tubing, or increasing the risk of a leak

Caution: Risk of Fire or Explosion due to the Flammable Refrigerant (R290) used for this appliance to satisfy Federal and local codes, ordinances and regulations.

Follow Handling Instructions Carefully in Compliance with all prevailing regulations that pertain to your location and this style of appliance.

Component parts shall be replaced with like components and that servicing shall be done by factory authorized service personnel, so as to minimize the risk of possible ignition due to incorrect parts or improper service.

CAUTION: Risk of Fire or Explosion Due to Puncture of Refrigerant Tubing; Follow Handling Instructions Carefully. Flammable Refrigerant Used

DANGER: Risk of child entrapment. Before you throw away your old refrigerator or freezer:

Take off the doors but leave the shelves in place so that children may not easily climb inside.

INSTALLATION

Location

Units represented in this manual are intended for indoor use only. Be sure the location chosen has a floor strong enough to support the total weight of the cabinet and contents. A fully loaded unit can weigh as much as 1500 pounds. Reinforce the floor as necessary to provide for maximum loading. For the most efficient refrigeration, be sure to provide good air circulation inside and out.



Do not block the rear wall louvers. At least 2" clearance is needed for proper air circulation and temperature regulation.

Inside cabinet

Do not pack the units so full that air cannot circulate. Obstructions to this air flow can cause evaporator coil freeze ups and loss of temperature or overflow of water from the evaporator drain pan. The shelves may have a rear turn up on them to help ensure that proper air movement/circulation will occur. However, bags and other items can still be located to the far rear of the cabinet and obstruct the needed air flow. Air is brought into the evaporator coil with fans. Prevent obstruction to allow the outlet or inlet of air flow.

Outside cabinet

Be sure that the unit has access to ample air. Avoid hot corners and locations near stoves and ovens. It is recommended that the unit be installed no closer than 2" from its rear wall. The ambient conditions should be less than 65% humidity with an ambient temperature between 65° and 80°F.

Leveling

A level cabinet looks better and will perform better because the doors will line up with the frames properly. Use a level to make sure the unit is level from front to back and side to side. Units supplied with legs will have adjustable bullet feet to make the necessary adjustments. If the unit is supplied with casters, no adjustments other than shimming them, are available. Ensure the floor where the unit is to be located is level. It is acceptable for the unit to slope up to ¼" down from the front to rear, which may help any condensate caused by the refrigeration system to be properly eliminated.

Stabilizing

All models are supplied with casters for your convenience. It is very important, however, that the cabinet be installed in a stable condition with the front wheels locked while in use. Should it become necessary to lay the unit on its side or back for any reason, allow at least 24 hours before start-up to allow compressor oil to flow back to place. Failure to meet this requirement can cause compressor failure and unit damage.



NOTE

Unit repairs will not be subject to standard unit warranties if due to improper installation or stocking procedures.

Electrical connection

Refer to the amperage data on page 5, the serial tag, your local code or the National Electrical Code to be sure the unit is connected to the proper power source.



DANGER

The unit should be turned OFF and disconnected from the power source whenever performing service, maintenance functions or cleaning the refrigerated area.

OPERATION



Do not throw items into the storage area. Failure to heed these recommendations could result in damage to the interior of the cabinet.

Refrigerated cabinets

Temperature range for the internal cabinets is 35° to 40°F for all undercounter refrigerators.

Continual frequent opening and closing of the appliance door may prevent the unit's ability to maintain optimum refrigeration temperature.

Proper programming or set up of the unit automatic defrost cycle will keep the evaporator from becoming frozen and allow the fans to properly circulate cooling air throughout the storage compartment.

Defrosting:

The factory default setting should be such that every 6 hours, the unit will turn off so the evaporator coil can defrost. The controller now displays the defrost symbol. When the coil temperature reaches the terminal temperature or after 20 minutes of defrost, the unit will turn on.

SOLID-STATE THERMOSTAT DESCRIPTIONS

FRONT PANEL COMMANDS



SET: To display target set point; in programming mode it selects a parameter or confirm an operation.



To start a manual defrost.



In programming mode it browses the parameter codes or increases the displayed value.



In programming mode it browses the parameter codes or decreases the displayed value.

KEY COMBINATIONS

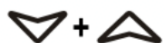

To lock or unlock the keyboard.







To enter in programming mode.



To return to room temperature display.

1.1 Function of LEDS



LED	MODE	SIGNIFICANCE
	On	Compressor enabled
	Flashing	Anti short cycle delay enabled (AC parameter)
	On	Defrost in progress
	Flashing	Dripping in progress
	On	Fans output enabled
	Flashing	Fans delay after defrost
	On	Measurement unit
	Flashing	Programming mode
	On	Measurement unit
	Flashing	Programming mode

MAIN FUNCTIONS



2.1 HOW TO SEE THE SETPOINT

1. Push and immediately release the **SET** key: the display will show the set point value. 
2. Push and immediately release the **SET** key or wait for 5 seconds to display the sensor value again.



2.2 HOW TO CHANGE THE SETPOINT

1. Push the **SET** key for more than 2 seconds to change the set point value.
2. The value of the set point will be displayed and the °C or °F LED starts blinking.
3. To change the set value push the  or  key within 10s.
4. To set new point value, push the SET key again or wait 10s.
- 5.

2.3 HOW TO START A MANUAL DEFFROST

Push the  key for more than 2 seconds and a manual defrost will start 

2.4 HOW TO LOCK THE KEYBOARD

1. Hold the  and  keys for more than 3s.
2. The “OFF” message will be displayed and the keyboard will be locked.
3. If a key is pressed more than 3s the ”OFF” message will be displayed.



2.5 HOW TO UNLOCK THE KEYBOARD

Hold the  and  keys together for more than 3s, until the “ON” message is displayed.

ALARM SIGNALS

ALARM RECOVERY

Probe alarms P1” and “P2” start some seconds after the fault in the related probe; they automatically stop some seconds after the probe restarts normal operation. Check connections before replacing the probe. Temperature alarms “HA” and “LA” automatically stop as soon as the temperature returns to normal values. Alarms “EA” and “CA” (with iF=bL) recover as soon as the digital input is disabled.

Mess.	Cause	Outputs
"P1"	Room probe failure	Compressor output according to "Cy" e "Cn"
"P2"	Evaporator probe failure	Defrost end is timed
"HA"	Maximum temperature alarm	Outputs unchanged
"LA"	Minimum temperature alarm	Outputs unchanged
"EA"	External alarm	Outputs unchanged
"CA"	Serious external alarm	All outputs OFF
"dA"	Door Open	Compressor and fans restarts

MAINTENANCE



The power switch must be turned OFF and the unit disconnected from the power source whenever performing service, maintenance functions or cleaning the refrigerated area.

Refrigerators and Freezers

The interior and exterior can be cleaned using a mild detergent and warm water. If this isn't sufficient, use a nonabrasive liquid cleaner, preferably one intended for use as a stainless steel cleaner and polisher. When cleaning the exterior, always rub with the "grain" of the stainless steel to avoid marring the finish.

Do not use an abrasive cleaner because it will scratch the stainless steel and plastic and can damage the breaker strips and gaskets. Always use a soft cloth or microfiber towel to apply cleaner and to dry the unit. Use of a stiff brush or pad can damage the protective chromium oxide layer on the surface.

Cleaning the Condenser Coil

The condenser coil requires regular cleaning. Cleaning is recommended every 90 days. In some instances, you may find that there is a large amount of debris and dust or grease accumulated prior to the 90 day time frame. In these cases the condenser coil should be cleaned every 30 days.

If the build up on the coil consists of only light dust and debris, the condenser coil can be cleaned with a simple brush. Heavier dust build-up may require a vacuum or even compressed air to blow through the condenser coil.

If heavy grease is present, there are de-greasing agents available for refrigeration use and specifically for the condenser coils. The condenser coil may require cleaning with the de-greasing agent and then blown

Failure to maintain a clean condenser coil can initially cause high temperatures and excessive run times. Continuous operation with dirty or clogged condenser coils can result in compressor failures. Neglecting the condenser coil cleaning procedures will void any warranties associated with the compressor or cost to replace the compressor.



Never use a high pressure water wash for this cleaning procedure as water can damage the electrical components located near or at the condenser coil.

In order to maintain proper refrigeration performance, the condenser fins must be cleaned of dust, dirt and grease regularly. It is recommended that this be done at least every three months. If conditions are such that the condenser is totally blocked in three months, the frequency of cleaning should be increased. Clean the condenser with a vacuum cleaner or stiff brush. If extremely dirty, a commercial-grade condenser cleaner may be required.

Stainless Steel Care and Cleaning

To prevent discoloration of rust on stainless steel, several important steps need to be taken. First, we need to understand the properties of stainless steel. Stainless steel is at least 70% iron which will rust. It also contains at least 12% chromium which forms an invisible passive film over the steels surface which acts as a shield against corrosion. As long as the protective layer is intact, the metal resists rusting. If the film is broken or contaminated, outside elements can begin to breakdown the steel and begin to form rust or discoloration. The use of chlorinated cleaners and hard water could result in staining and/or pitting of the stainless surface.



NEVER USE STEEL PADS, WIRE BRUSHES OR SCRAPERS, OR EXPOSE THE SURFACE TO HARSH CLEANERS, HARD WATER, ACIDS OR CORROSIVE LIQUIDS

Cleaning solutions need to be mild detergent/soap or non-chloride based. Any cleaner containing chlorides will damage the protective film of the stainless steel. Chlorides are commonly found in hard water, salts, and household and industrial cleaners. If cleaners containing chlorides are used, be sure to rinse and dry thoroughly.

Routine cleaning of stainless steel can be done with soap and water. Extreme stains or grease should be cleaned with a non-abrasive cleaner and plastic scrub pad. It is always good to rub with the grain of the steel. There are also stainless steel cleaners available which can restore and preserve the finish of the steels protective layer.

Early signs of stainless steel breakdown can consist of small pits and cracks. If this has begun, clean thoroughly and start to apply stainless steel cleaners in attempt to restore the passivity of the steel. CitriSurf is a compound that will passivate the protective chromium oxide surface if it has been penetrated and restore the luster to the stainless surface.



Never use an acid based cleaning solution! Many food products have an acidic content which can deteriorate the finish. Be sure to clean all stainless steel surfaces.

MAINTENANCE (cont.)

Gasket Maintenance

Gaskets require regular cleaning to prevent mold and mildew build up and also to keep the elasticity of the gasket. Gasket cleaning can be done with the use of warm soapy water. Avoid full strength cleaning products on gaskets as this can cause them to become brittle and prevent proper seals. Do not use sharp tools or knives to scrape or clean the gasket which could possibly tear the gasket and rip the bellows.

Gaskets can easily be replaced and don't require the use of tools or authorized service technicians. The gaskets are "Dart" style and can be pulled out of the groove in the door and replaced by pressing the new one back into place. It is recommended to help hold the gasket in place that every 10" (260mm) a dab of gasket adhesive be applied to help the slot retain the gasket in place.

Doors/Hinges

Over time and with heavy use, door hinges may become loose. If the door is beginning to sag, tighten the screws that mount the hinge brackets to the frame of the unit. If the doors are loose or sagging this can cause the hinge to pull out of the frame which may damage to both the doors and the door hinges.

Drain Maintenance

Each unit has a drain located inside the unit which removes the condensation from the evaporator coil and evaporates it into an external condensate evaporator pan. Each drain can become loose or disconnected from moving or bumping the drain. If you notice excessive water accumulation on the inside of the unit, be sure the drain tube is connected from the evaporator housing to the condensate evaporator drain pan. If water starts to collect underneath the unit, you may want to check the condensate evaporator drain tube to be sure it is still located inside the drain pan. The leveling of the unit is important as the units are designed to drain properly when on a level surface. If your floor is not level this can also cause drain problems. Be sure all drain lines are free of obstructions because this may cause water to back up and overflow the drain pans.

TROUBLESHOOTING

Fault	Probable Cause	Action
Compressor is Not Running	Fuse blown or circuit breaker tripped	Replace fuse or reset circuit breaker.
	Power cord unplugged	Plug in power cord
	Thermostat set too high	Set thermostat to lower temperature
Cabinet Temperature is too Warm	Thermostat is set too high	Set thermostat to lower temperature.
	Airflow is blocked	Re-arrange stored products to allow for proper air flow. Make sure there is at least 1 ½ inches clearance from fan louvered panel
	Low refrigerant levels	Contact a service technician to check refrigerant levels
	Door is slightly ajar	Make sure door is completely closed.
Condensation is Collecting on the Cabinet and/or Floor	Gasket is not sealing properly	Clean, repair, or replace the gasket as necessary

SPECIFICATION & PARTS LIST

UNDERCOUNTER & WORKTOP REFRIGERATORS								
MODEL#	V/Hz/Ph	AMPS	STORAGE CAPACITY (Nominal/ Actual) Cu-ft	COMPRESSOR RATED HP	SHELF CAPACITY Sq-ft	COOLING RATE BTU	CHARGE OZ	NEMA PLUG
MXCR27U-FBHC	115/60/1	1.5	6.5 / 5.0	3/8	14	2800	2.47	5-15P

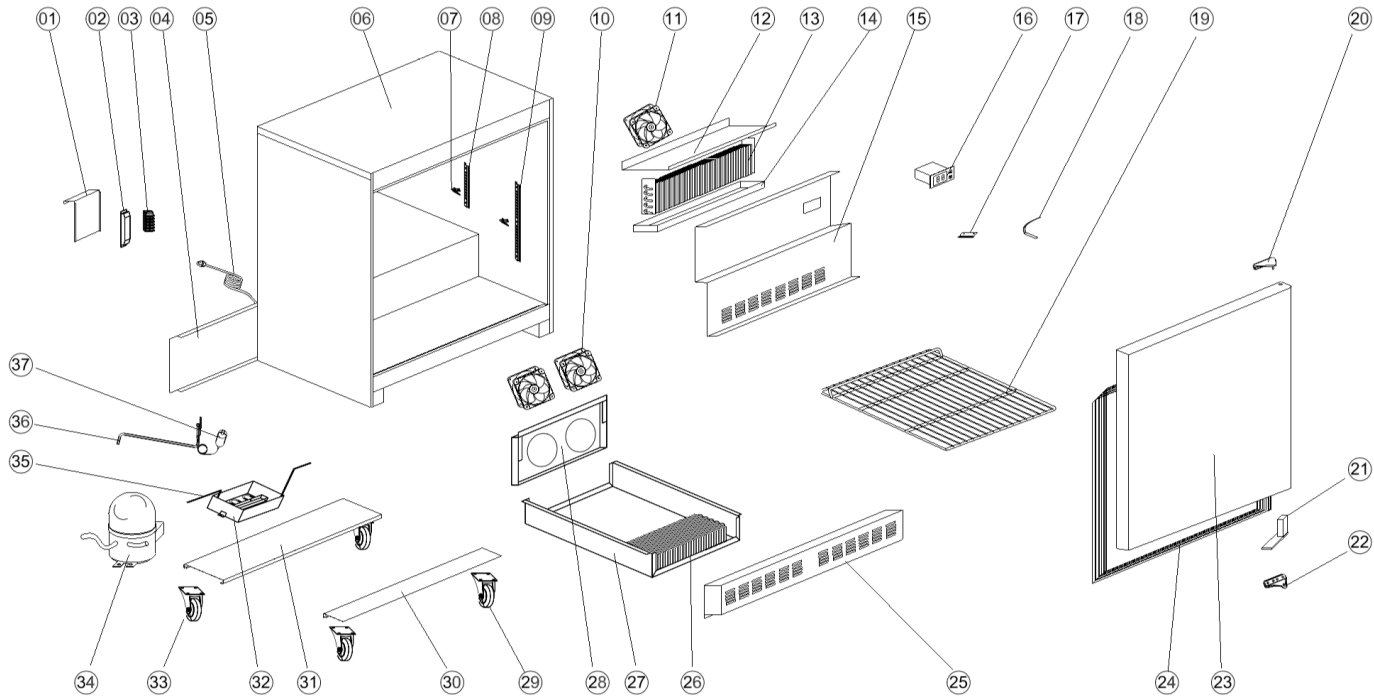

Number	Description	Number	Description
1	CONNECTOR SUPPORT	20	UP HINGE
2	POWER SUPPLY	21	DOOR SPRING HINGE
3	CABLE CONNECTOR	22	DOWN HINGE
4	BACK BOARD	23	DOOR
5	PLUG	24	GASKET
6	BODY	25	FRONT PANEL
7	K SHAPE CLIP	26	CONDENSER
8	SHELF SUPPORT B	27	CONDENSER BOX
9	SHELF SUPPORT A	28	CONDENSER FAN SUPPORT
10	CONDENSER FAN	29	BRAKE WHEEL
11	EVAPORATOR FAN	30	FRONT SUPPORT OF UNIT BOARD
12	CIRCLE FAN SUPPORT	31	UNITE BOARD
13	EVAPORATOR	32	WATER BOX
14	EVAPORATOR WATER PAN	33	NORMAL WHEEL
15	EVAPORATOR COVER	34	COMPRESSOR
16	THERMOSTAT	35	EVAPORATE PIPE
17	SENSOR FIXED CLIP	36	SUCTION PIPE
18	SENSOR	37	FILTER DRIER
19	SHELF		

WIRING DIAGRAMS

MODEL: MXCR27U-FBHC

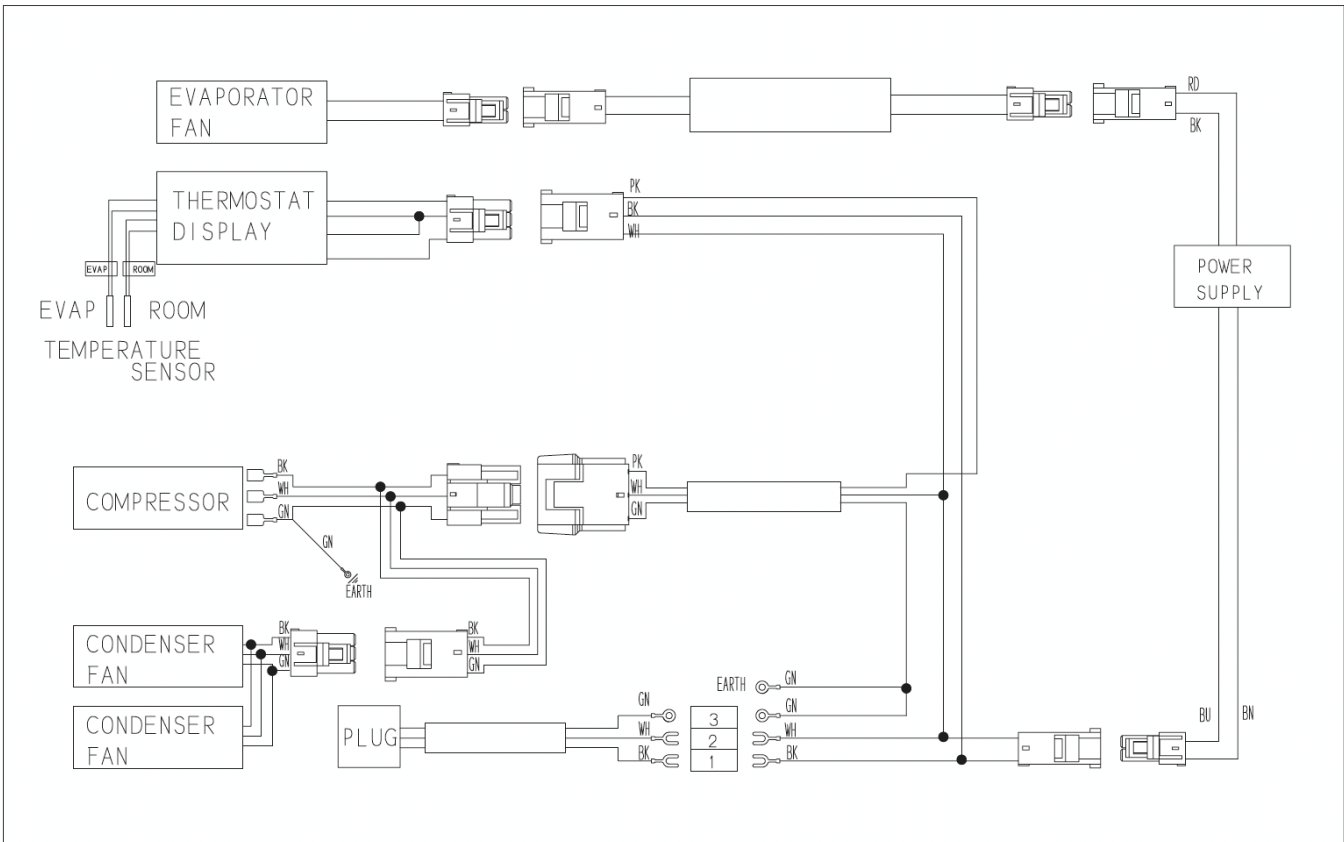
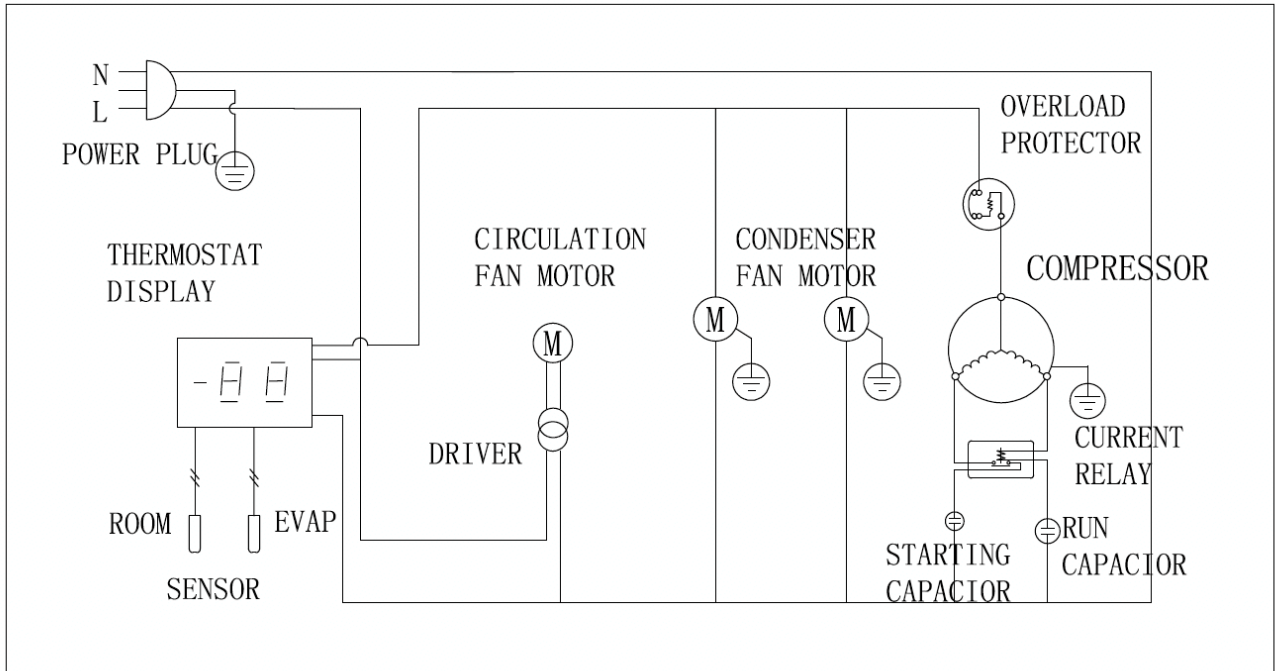



MAXX COLD
X-series

3355 Enterprise Ave., Suite 160 - Ft. Lauderdale, FL 33331
T: (954) 832-3724 - F: (954) 202-7337
www.maximumfoodservice.com