

# Hot Water Pressure Washer

**Model:** HPW40H / HPW40HT / HPW40HBT  
HPW40K / HPW40KT / HPW40KBT  
HPW40D / HPW40DT / HPW40DBT



## Operator's Manual

**MechMaxx**

[www.mechmaxx.com](http://www.mechmaxx.com)



---

**CATALOGUE**

---

<b>INTRODUCTION</b> .....	<b>2</b>
<b>IMPORTANT SAFETY WARNINGS</b> .....	<b>3</b>
<b>REFERENCE GUIDE</b> .....	<b>5</b>
<b>SPECIFICATIONS</b> .....	<b>6</b>
<b>COMPONENT IDENTIFICATION</b> .....	<b>10</b>
<b>OPERATING INSTRUCTIONS</b> .....	<b>15</b>
<b>CHEMICAL APPLICATION</b> .....	<b>20</b>
<b>STORAGE &amp; WINTERIZING</b> .....	<b>20</b>
<b>GENERAL MAINTENANCE</b> .....	<b>21</b>
<b>MAINTENANCE CHECKLIST</b> .....	<b>22</b>
<b>QUICK DIAGNOSTICS AND SOLUTIONS GUIDE</b> .....	<b>24</b>
<b>SERVICE MANUAL</b> .....	<b>27</b>
<b>WIRING DIAGRAMS</b> .....	<b>39</b>
<b>PARTS DIAGRAMS</b> .....	<b>41</b>
<b>PARTS LIST</b> .....	<b>43</b>
<b>PUMP DIAGRAMS</b> .....	<b>45</b>
<b>PARTS LIST</b> .....	<b>46</b>
<b>PUMP DIAGRAMS</b> .....	<b>48</b>
<b>PARTS LIST</b> .....	<b>49</b>

---

## INTRODUCTION

---

### **Thank You for Choosing Our Product**

Thank you for selecting a high-quality product. We are pleased to welcome you among the many satisfied owners of our cleaning machines. Years of engineering and innovation have gone into the development of these exceptional products, using only top-quality components and materials throughout. Each machine is carefully tested and inspected before leaving our facility to ensure reliable performance for years to come.

### **Maximizing Your Investment**

To continue receiving optimal performance, it's important to remember that this machine represents a significant investment. With proper care and maintenance, it will return that investment many times over. Like all mechanical equipment, your machine requires proper operation and upkeep, as outlined in this manual, to ensure a long and trouble-free life.

### **Expertly Designed and Tested**

This manual has been prepared under the guidance of our engineering and service technicians. With years of experience in designing, manufacturing, installing, and servicing our equipment, they have condensed their knowledge into this document. They understand what information is needed to help you achieve the best performance from your pressure washer. Please read the manual carefully.

### **Important Information and Safety Notices**

This manual contains specific information for your pressure washer as well as for similar models. Please review any additional manuals that have been included with your system, and be sure to follow all additional operating instructions and safety notices. These are tailored to the high-quality components used in your machine and are a critical part of the operating and maintenance procedures.

### **Our Commitment to You**

Our goal is for you to be completely satisfied with the performance, quality, and service of our product. Should you need to replace this machine in the future, we hope you will give us the opportunity to continue supplying equipment to your company.

### **Important Reminders**

- **Read the manuals carefully before using the machine.**
- **Examine the machine and crate carefully for any shipping damage or missing parts.**
- **Report any shortages or damage claims promptly to the freight carrier or dealer.**

## IMPORTANT SAFETY WARNINGS

The safe operation of our pressure washing systems is the top priority. This can only be achieved by carefully following the operation and maintenance instructions provided in this manual and any other accompanying documents.

This manual contains essential information about safety hazards, proper operation, and maintenance procedures related to the equipment. It should always remain with the machine, even if the machine is resold.

**ALL CAUTIONS AND SAFETY WARNINGS MUST BE FOLLOWED** to prevent injury or damage to the equipment.

**THIS EQUIPMENT SHOULD ONLY BE USED BY TRAINED OPERATORS** and must always be monitored during operation.



### Read the Owner's Manual Thoroughly.

Failure to follow instructions could cause malfunction of the machine and result in death, serious bodily injury and/or property damage.



### Use Protective Gear.

High pressure spray can cause paint chips or other particles to become airborne and fly at high speeds. Use protective eyewear and clothing when operating. This machine exceeds 85db. Appropriate ear protection must be worn.



### Beware of Gun Back Pressure.

Be extremely careful when using a ladder, scaffolding or any other relatively unstable location. The cleaning area should have adequate slopes and drainage to reduce the possibility of a fall due to slippery surfaces.



### Risk of Explosion.

Operate only where open flame or torch is permitted. Flammable liquids can create fumes which can ignite, causing property damage or severe injury.



### Trigger Gun Kicks Back.

Hold with both hands firmly during start up and operation. Use only designed gripping areas. Make sure all quick coupler fittings are properly secured before operating pressure washer.



### Risk of Electrocution.

Do not direct spray on or into electrical installations of any kind. All electrically powered equipment must be grounded at all times. Make sure machine is disconnected from power source before servicing.



### Risk of Injection and Laceration.

Keep Clear of Nozzle. High pressure spray can cause serious injuries. Never point pressurized spray at any person or animal. Handle the spray assembly with care. Always keep operating area clear of other people.



### Risk of Fire.

Do not add fuel when the machine is operating or still hot. Never use gasoline, crankcase draining, waste oil or oil containing gasoline, solvents or alcohol in your burner fuel tank. The minimum distant to any combustible materials is 12 inches.



**Risk of Chemical Exposure.**

Use of acids, insecticides, toxic/corrosive chemicals, or any flammable solvent with this machine could result in serious injury or death.



**Do Not Touch Hot Surfaces.**

Outlet fittings/coil/engine/muffler/burner/components may be very hot and cause burns. Do not touch directly when using.



**Protect from Freezing.**

Keep your machine from freezing. Failure to protect your machine from freezing may cause damage and personal injuries may occur as a result.

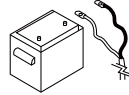

**Risk of Injury.**

For machines with a 12 V Burner, must disconnect battery ground terminal before servicing.

**⚠ DANGER ⚠**

**FOR OUTDOOR USE ONLY!** Using this machine indoors can kill you in minutes. Engine exhaust and burner exhaust contain carbon monoxide. This is a poison you cannot see or smell which can cause poisoning or death.

<p>Never use inside any building, garage of structure, even if doors and windows are open.</p>	<p>Only use outside and far away from windows, vents, and doors.</p>
--	--

FOR OUTDOOR USE ONLY! Using this machine indoors can kill you in minutes.

Engine exhaust and burner exhaust contain carbon monoxide. This is a poison you cannot see or smell which can cause poisoning or death.

**Never run the pump dry** (without water or oil) or allow the pump to operate with the trigger gun released for more than 2 minutes. Continuous operation when idle may cause pump damage.

**Protect high-pressure hoses** from sharp objects and vehicles. Always inspect hoses for damage before use to avoid serious injury.

**Do not allow acids, caustic substances, or abrasive fluids** to pass through the pump.

**Do not overextend or stand on unstable supports.** Always maintain good footing and balance.

**Do not operate the machine when fatigued** or under the influence of alcohol, prescription medications, or drugs.

**Some maintenance procedures require a certified technician** (indicated throughout this manual). Do not attempt these repairs unless you are qualified.



---

## REFERENCE GUIDE

---

**PSI (Pounds per Square Inch):**

Pressure washers are designed and rated to operate at a specific PSI. Operating at pressures exceeding the maximum rating could result in damage to the unit and/or **SEVERE PERSONAL INJURY**.

**GPM (Gallons per Minute):**

The orifice on the pressure wand assembly is selected to deliver the maximum GPM for your machine.

**BTU (British Thermal Unit):**

It represents the amount of work or energy required to increase the temperature of one pound of water by one degree Fahrenheit.

**Pressure Wand Assembly:**

This refers to the gun, wand, and nozzle.

**Pump:**

The pump moves water through the system and delivers it to the pressure wand assembly.

**Unloader Valve:**

A valve located at the head of the pump that unloads water back into the bypass when the trigger gun is released. It also reduces the load on the pump when the gun is off.

**Chemical Injection System:**

Mixes cleaners or cleaning solvents with the water to improve cleaning effectiveness.

**Pump Oil:**

The oil used to lubricate the pump's operation. **Use SAE 85W/90 Non-Detergent Oil.**

**Engine Oil:**

Gasoline engines require appropriate lubricant. **Use SAE 10W/30 Detergent Oil.**

**Burner Assembly:**

A device used to change fuel into heat energy. The burner heats the water in hot water pressure washers. It is located under the coil and may be powered by furnace oil or diesel fuel.

**Maximum Working Pressure:**

The water heater coils are designed to operate safely at the normal working pressure. Each machine is equipped with a safety pressure relief valve to prevent over-pressurization of the high-pressure system. This is a critical safety device and must not be tampered with.

**Temperature Control:**

The water heater is equipped with a temperature control that shuts down the burner if the outlet temperature becomes excessive due to insufficient water flow through the heater coil.

**12-Volt DC Battery (if equipped):**

The 12-volt battery powers the engine's electrical starting system. Once the engine starts, the system charges the battery and operates the burner. Regular replacement of the 12-volt battery is necessary to maintain consistent performance.

## SPECIFICATIONS

Model	HPW40H	HPW40HT	HPW40HBT
<b>Specifications</b>			
<b>Machine Type</b>	Portable with 13" Pneumatic Tires	Truck Skid Mount with 175 gal Water Tank	Truck Skid Mount with 245 gal Water Tank
<b>Pressure Range</b>	3500-4000 PSI		
<b>Flow Rate</b>	4.0 GPM		
<b>BTU Per Hour</b>	350,700 BTU		
<b>Max Temperature</b>	200°F (93°C)		
<b>Igniter</b>	12V		
<b>Burner Fuel</b>	5 US gal (19L) Diesel		
<b>Drive</b>	Direct		
<b>Engine</b>			
<b>Engine Model</b>	HONDA GX390		
<b>Engine Type</b>	Single Cylinder, 4 Stroke, Air-Cooled, OHV		
<b>Displacement</b>	389 cc; 11.7 HP		
<b>Start Type</b>	Electric Start (battery included)		
<b>Engine Fuel</b>	Clean, fresh, unleaded gasoline		
<b>Engine Oil</b>	SAE 10W-30		
<b>Pump</b>			
<b>Pump Type</b>	Triplex Plunger Pump / Oil Bath Crankcase		
<b>Pump Oil</b>	SAE 85W/90 Non Detergent		
<b>Standard Accessories</b>			
<b>Hose</b>	3/8" x 50' High Pressure Hose		
<b>Nozzles</b>	0°, 15°, 25°, 40° and Chemical		
<b>Spry Gun &amp; Wand</b>	36° Spry Gun & Wand Assembly		
<b>Hose Reel</b>	Included		
<b>Siphon Tube</b>	Included		
<b>LED Work Lights</b>	Not Included	Included	Included

Model	HPW40K	HPW40KT	HPW40KBT
<b>Specifications</b>			
<b>Machine Type</b>	Portable with 13" Pneumatic Tires	Truck Skid Mount with 175 gal Water Tank	Truck Skid Mount with 245 gal Water Tank
<b>Pressure Range</b>	3500-4000 PSI		
<b>Flow Rate</b>	4.0 GPM		
<b>BTU Per Hour</b>	350,700 BTU		
<b>Max Temperature</b>	200°F (93°C)		
<b>Igniter</b>	12V		
<b>Burner Fuel</b>	5 US gal (19L) Diesel		
<b>Drive</b>	Direct		
<b>Engine</b>			
<b>Engine Model</b>	KOHLER CH440		
<b>Engine Type</b>	Single Cylinder, 4 Stroke, Air-Cooled, OHV		
<b>Displacement</b>	429 cc; 14 HP		
<b>Start Type</b>	Electric Start (battery included)		
<b>Engine Fuel</b>	Clean, fresh, unleaded gasoline		
<b>Engine Oil</b>	SAE 10W-30		
<b>Pump</b>			
<b>Pump Type</b>	Triplex Plunger Pump / Oil Bath Crankcase		
<b>Pump Oil</b>	SAE 85W/90 Non Detergent		
<b>Standard Accessories</b>			
<b>Hose</b>	3/8" x 50' High Pressure Hose		
<b>Nozzles</b>	0°, 15°, 25°, 40° and Chemical		
<b>Spry Gun &amp; Wand</b>	36" Spry Gun & Wand Assembly		
<b>Hose Reel</b>	Included		
<b>Siphon Tube</b>	Included		
<b>LED Work Lights</b>	Not Included	Included	Included



Model	HPW40D	HPW40DT	HPW40DBT
<b>Specifications</b>			
<b>Machine Type</b>	Portable with 13" Pneumatic Tires	Truck Skid Mount with 175 gal Water Tank	Truck Skid Mount with 245 gal Water Tank
<b>Pressure Range</b>	3500-4000 PSI		
<b>Flow Rate</b>	4.0 GPM		
<b>BTU Per Hour</b>	350,700 BTU		
<b>Max Temperature</b>	200°F (93°C)		
<b>Igniter</b>	12V		
<b>Burner Fuel</b>	5 US gal (19L) Diesel		
<b>Drive</b>	Direct		
<b>Engine</b>			
<b>Engine Model</b>	ZONSEN GB460		
<b>Engine Type</b>	Single Cylinder, 4 Stroke, Air-Cooled, OHV		
<b>Displacement</b>	459 cc; 15 HP		
<b>Start Type</b>	Electric Start (battery included)		
<b>Engine Fuel</b>	Clean, fresh, unleaded gasoline		
<b>Engine Oil</b>	SAE 10W-30		
<b>Pump</b>			
<b>Pump Type</b>	Triplex Plunger Pump / Oil Bath Crankcase		
<b>Pump Oil</b>	SAE 85W/90 Non Detergent		
<b>Standard Accessories</b>			
<b>Hose</b>	3/8" x 50' High Pressure Hose		
<b>Nozzles</b>	0°, 15°, 25°, 40° and Chemical		
<b>Spry Gun &amp; Wand</b>	36" Spry Gun & Wand Assembly		
<b>Hose Reel</b>	Included		
<b>Siphon Tube</b>	Included		
<b>LED Work Lights</b>	Not Included	Included	Included



**⚠ WARNING ⚠**



**Read the Owner's Manual Thoroughly.** Failure to follow instructions could cause malfunction of the machine and result in death, serious bodily injury and/or property damage.



**Use Protective Gear.** High pressure spray can cause paint chips or other particles to become airborne and fly at high speeds. Use protective eyewear and clothing when operating. This machine exceeds 85db. Appropriate ear protection must be worn.



**Beware of Gun Back Pressure.** Be extremely careful when using a ladder, scaffolding or any other relatively unstable location. The cleaning area should have adequate slopes and drainage to reduce the possibility of a fall due to slippery surfaces.



**Trigger Gun Kicks Back.** Hold with both hands firmly during start up and operation. Use only designed gripping areas. Make sure all quick coupler fittings are properly secured before operating pressure washer.



**Risk of Explosion.** Operate only where open flame or torch is permitted. Flammable liquids can create fumes which can ignite, causing property damage or severe injury.



**Risk of Electrocution.** Do not direct spray on or into electrical installations of any kind. All electrically powered equipment must be grounded at all times. Make sure machine is disconnected from power source before servicing.



**Risk of Injection and Laceration.** Keep Clear of Nozzle. High pressure spray can cause serious injuries. Never point pressurized spray at any person or animal. Handle the spray assembly with care. Always keep operating area clear of other people.



**Risk of Fire.** Do not add fuel when the machine is operating or still hot. Never use gasoline, crankcase draining, waste oil or oil containing gasoline, solvents or alcohol in your burner fuel tank. The minimum distance to any combustible materials is 12 inches.



**Risk of Chemical Exposure.** Use of acids, insecticides, toxic/corrosive chemicals, or any flammable solvent with this machine could result in serious injury or death.



**Do Not Touch Hot Surfaces.** Outlet fittings/coil/engine/muller/burner-components may be very hot and cause burns. Do not touch directly when using.

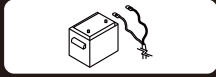

**Risk of Injury.** For machines with a 12 V Burner, must disconnect battery ground terminal before servicing.



**Protect from Freezing.** Keep your machine from freezing. Failure to protect your machine from freezing may cause damage and personal injuries may occur as a result.

**⚠ DANGER ⚠**

**FOR OUTDOOR USE ONLY!** Using this machine indoors can kill you in minutes. Engine exhaust and burner exhaust contain carbon monoxide. This is a poison you cannot see or smell which can cause poisoning or death.

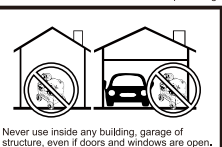

Never use inside any building, garage of structure, even if doors and windows are open.

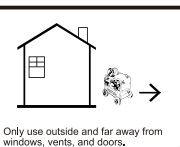

Only use outside and far away from windows, vents, and doors.

**⚠ WARNING ⚠**

USE **DIESEL** OR **FUEL OIL** ONLY  
(DO NOT USE KEROSENE,  
DO NOT OVERFILL)

OIL TANK CAPACITY: **5 US Gal**

**NOTE HOT TEMPERATURE**

**⚠ CAUTION ⚠**

**SAE 85W-90 non-detergent oil**

1/2

Operating the pump with low or no oil will cause permanent damage. Ensure the pump oil level reaches halfway up the sight glass. **CHECK OIL BEFORE EVERY USE!**

Running the pump with **NO WATER** or **DRY RUNNING** will cause permanent damage and void warranty. **CHECK WATER BEFORE EVERY USE!**

The white plug is for shipping only. Before first use, replace it with the grey vented plug.

**⚠ READ THE PRODUCT MANUALS CAREFULLY BEFORE USING THE MACHINE**

1. This machine **DOES NOT COME WITH OIL AND GASOLINE** in the engine. Before starting, fill the engine with both oil and gasoline. Refer to the engine manual for details.
2. Use **ONLY CLEAN DIESEL FUEL** when filling the diesel tank. Dirty or contaminated fuel can clog the fuel nozzle, cause black smoke, and potentially damage the machine.
3. Connect the battery before start the engine. Start the engine, warm it up, then set to **NO CHOKE** and **FULL THROTTLE**, or black smoke may occur.

**⚠ READ THE PRODUCT MANUALS CAREFULLY BEFORE USING THE MACHINE**

4. Before using the pump, replace the white plug with **THE GREY PLUG** provided in the accessory kit. And check that the **PUMP OIL LEVEL** reaches halfway up the sight glass.
5. Empty **THE DIRTY WATER** in the coil so clean water can come through.
6. The pump is factory-set to the proper pressure. **DO NOT ATTEMPT TO ADJUST IT** — doing so may damage the pump and result in pressure loss.
7. If the machine encounters any issues, please **CONTACT US FOR SUPPORT**. Damage caused by unauthorized repairs will void the warranty.

**WATER OUTLET**

**WATER INLET**



## COMPONENT IDENTIFICATION

This section provides an overview of the key components of your pressure washer. Familiarizing yourself with these parts will help ensure proper operation, maintenance, and troubleshooting.

### HPW40H / HPW40K / HPW40D



### HPW40HT / HPW40KT / HPW40DT

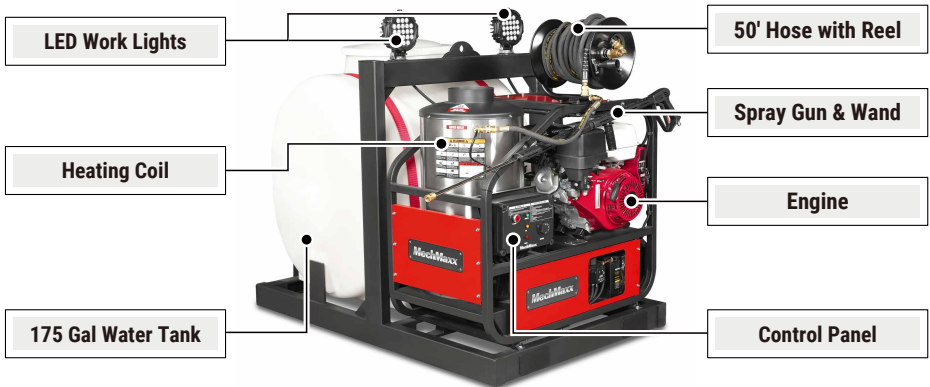

**HPW40HBT / HPW40KBT / HPW40DBT**

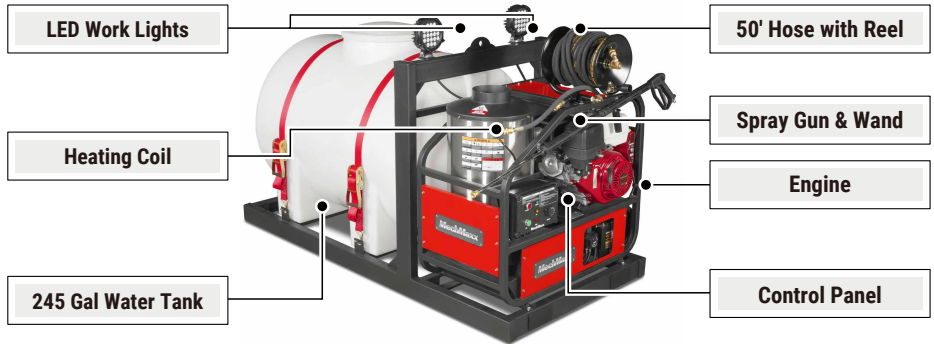

**High Pressure Pump Assembly**

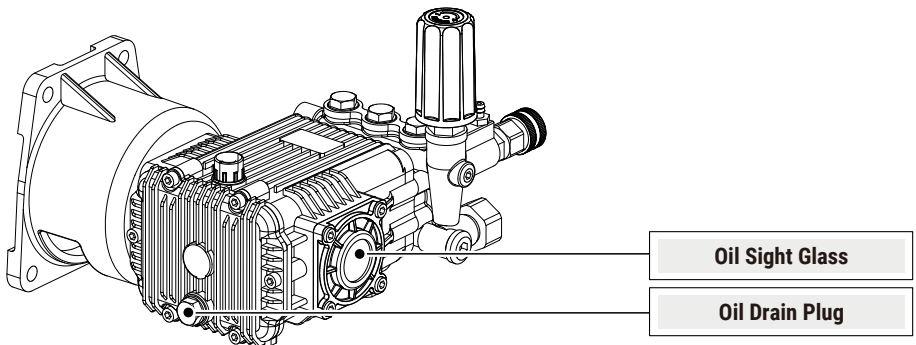
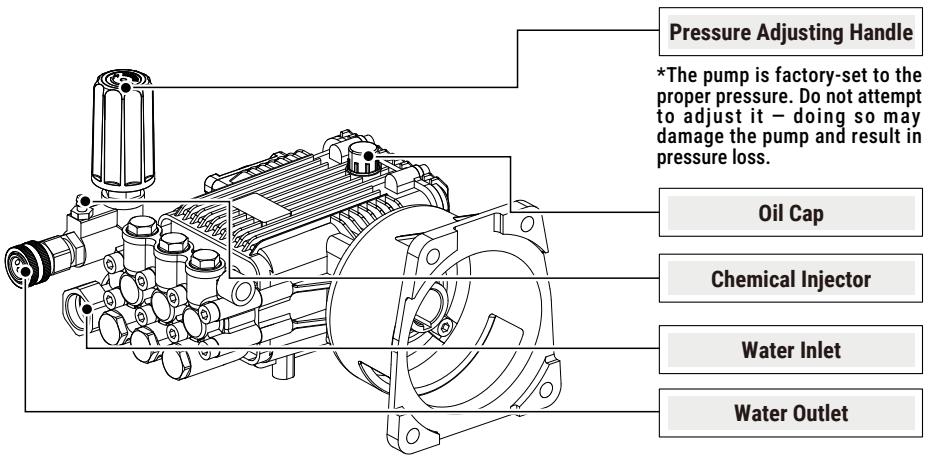

### Spray Gun & Wand Assembly

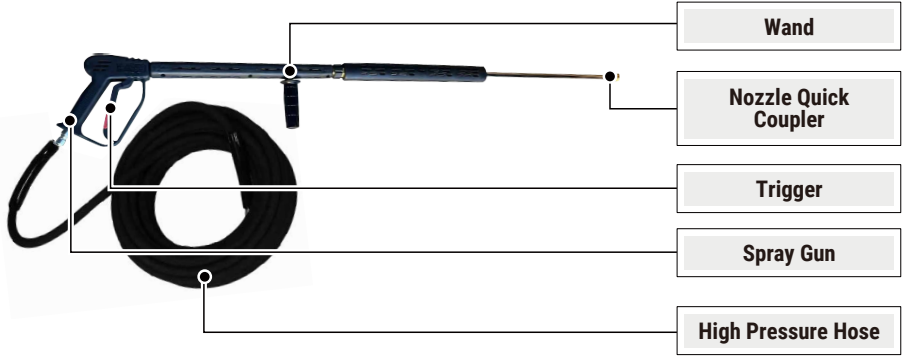

### Nozzles

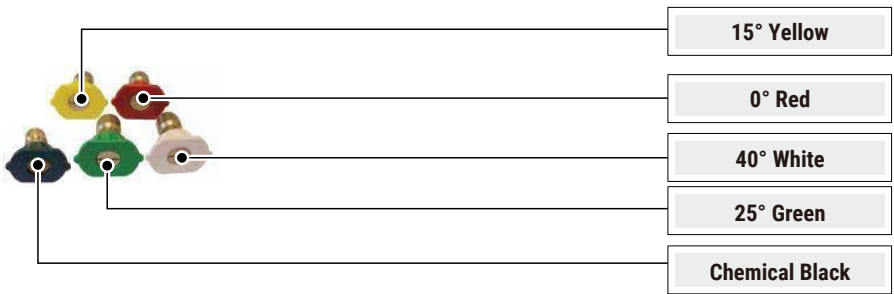

## Electrical Control Center:

### Important Note:

This high pressure washer is a hot and cold machine. If you do not use hot water, do not operate the electrical control center

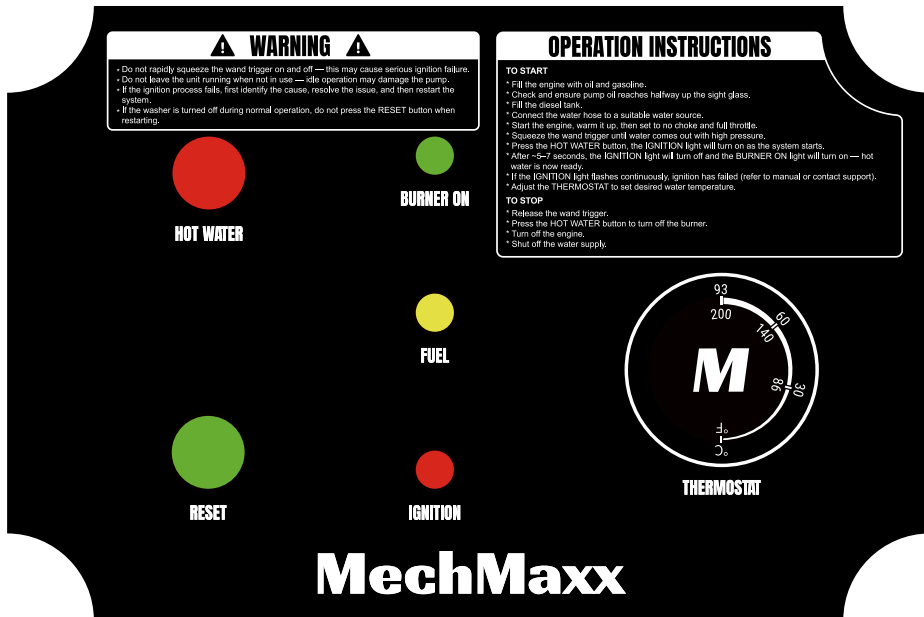

**OPERATION INSTRUCTIONS**

**TO START**

- Fill the engine with oil and gasoline.
- Check and ensure pump oil reaches halfway up the sight glass.
- Fill the diesel tank.
- Connect the water hose to a suitable water source.
- Start the engine, warm it up, then set to no choke and full throttle.
- Squeeze the wand trigger and water comes out with high pressure.
- Press the HOT WATER button, the IGNITION light will turn on as the system starts.
- After ~5~7 seconds, the IGNITION light will turn off and the BURNER ON light will turn on — hot water is now ready.
- If the IGNITION light flashes continuously, ignition has failed (refer to manual or contact support).
- Adjust the THERMOSTAT to set desired water temperature.

**TO STOP**

- Release the wand trigger.
- Press the HOT WATER button to turn off the burner.
- Turn off the engine.
- Shut off the water supply.

## Switch:

### 1. HOT WATER: Hot Water Button Switch

-To use hot water for cleaning, press the hot water button. This switch has a self-locking function. Press once to turn on, and press again to turn off.

### 2. RESET: Reset Button Switch

-If the washer was turned off during normal operation, there is no need to press the RESET button when starting the machine again.

-If the machine fails to ignite, or ignites but does not produce a flame successfully, the IGNITION light will start flashing. Troubleshoot to resolve the issue. Once the problem is fixed, press the RESET button for about 3 seconds until the light stops flashing before restarting the machine.

### Important Note:

To avoid accidental incorrect operation during troubleshooting, the electrical control center is designed with a memory function. The machine can only start working properly after the RESET button is pressed following successful troubleshooting.

### 3. THERMOSTAT: Temperature Control Switch

-This switch controls the water temperature.



## **Indicator Lights:**

### **1. BURNER ON**

-When the machine ignites and successfully produces a flame, the combustion chamber is working properly, and the BURNER ON light will turn green.

### **2. FUEL**

-If the diesel fuel is low, the FUEL light will turn yellow.

### **3. IGNITION**

When you start the engine:

-If you do not need hot water, do not turn on the HOT WATER switch. Simply pull and hold the trigger to get high-pressure water.

-If you need hot water, turn on the HOT WATER switch. Then, pull and hold the trigger on the wand until you feel high-pressure water. The IGNITION light will turn on, indicating that the ignition process has started. Once ignition is successful and the flame is on, the burner will stop automatically.

-If the IGNITION light starts flashing, it means ignition has failed or the flame has gone out. In this case, stop the machine immediately and proceed with troubleshooting.

## OPERATING INSTRUCTIONS

### 1. Pre-Start Maintenance Inspection

Before operating the machine, perform a pre-start maintenance inspection on all applicable systems. This is essential for the safe, effective, and efficient operation of the pressure washer. You will achieve optimal performance only if these instructions and inspections are followed. Any indication that the pressure washing system was not operated or maintained according to these instructions may void the manufacturer's warranty.

**Location:**

-Ensure the machine is installed in an area with sufficient air ventilation to support the combustion of oil in the burner.

**Controls:**

-Verify that all controls are turned to the off position.

**Electrical Components:**

-Visually inspect all electrical components to ensure they are in good condition and show no signs of exposure, breakage, or splicing.

**Hoses, Nozzles, and Guns:**

-Visually inspect all hoses, nozzles, and guns to ensure they are in good condition.

If replacements are necessary, they must be rated to withstand the machine's operating pressure and temperatures.

### 2. Battery Connections (Battery Included with the Machine)

The pressure washer is equipped with a 12-volt standard battery. Follow these steps for connecting and disconnecting the battery:

**-Connecting Sequence**

Connect the red cable to the positive (+) terminal of the battery.

Then, connect the black cable to the negative (-) terminal of the battery. **(The black cable is pre-installed on the negative terminal)**

**-Disconnecting Sequence**

First, disconnect the black cable from the negative (-) terminal of the battery.

Next, disconnect the red cable from the positive (+) terminal of the battery.

**WARNING:** Always disconnect the black, negative (-) battery cable first and connect it last.

**WARNING:** Always wear eye protection and protective clothing when handling batteries.

**WARNING:** Never smoke or work near sparks or other ignition sources.

**WARNING:** Never touch both battery terminals simultaneously with your hand or any non-insulated tools.

**WARNING:** If battery acid contacts skin or clothing, immediately flush with water and neutralize with baking soda. If it enters the eye, immediately flush the eye with running cold water for at least 15 minutes and seek immediate medical attention.

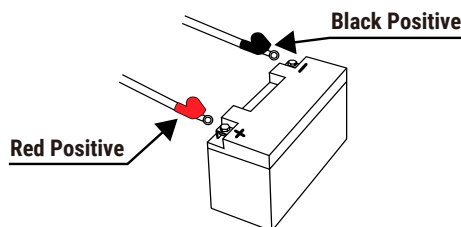



**7. Install Hose Reel and Connect High-Pressure Water Hose**

- Use a high-pressure hose to connect the hot water outlet to the hose reel.
- Install the 50' high-pressure hose onto the hose reel, then attach the hose (with a quick coupler) to the spray gun.
- Ensure that all quick disconnect connections are tightly locked. To confirm they are secure, apply a sharp pull on the hose.

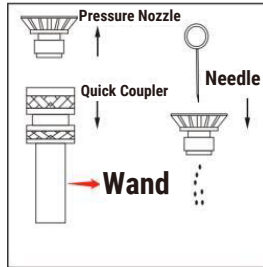
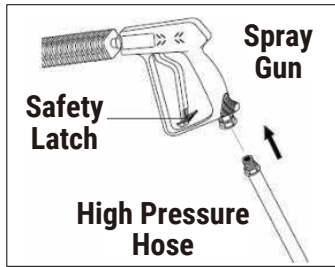

**8. Attach Wand Nozzle Specific to Task Requirements**

- Quick Coupling Operation:
- Pull back the sleeve on the quick coupler.
- Insert the male end into the nozzle quick coupler.
- Release the sleeve and confirm the connection by pulling on the nozzle.

**9. Attach Water Source to Pump Water Inlet**

- The water source must be connected using a high-quality, standard garden-type hose (minimum 5/8" ID).
- Connect the fitting of the hose to the pump inlet fitting. Ensure that the inlet screen/filter is intact and properly fitted.
- Turn on the water source. **The water supply must be sufficient, and the pressure must be between 20–60 PSI to ensure proper and safe operation.**
- If using a well water supply, ensure that the water level does not fall more than 10 feet below the pump.
- Ensure water is flowing from the nozzle when the trigger gun is pulled to deplete the system of air.

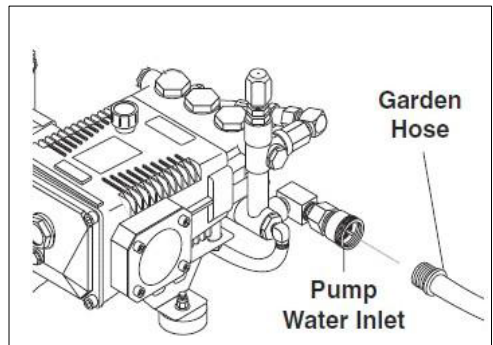
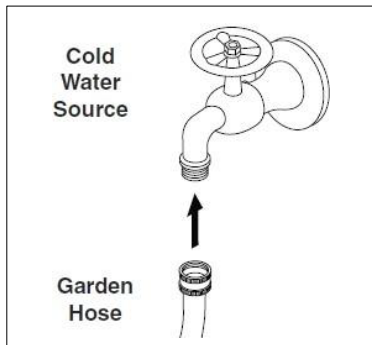

**10. Start Gas Engine**

- Refer to the instructions in the engine manual for proper startup procedures. **Ensure the engine exhaust is not directed toward any flammable materials to prevent fire hazards.**



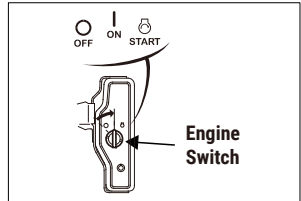
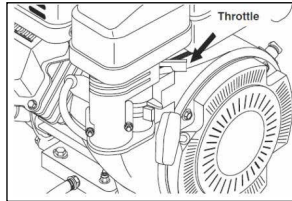
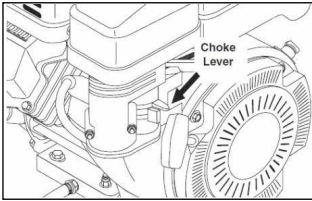

## 11. Burner Operation

-Ensure water is flowing through the water heater coil before turning on the HOT WATER switch. Set the thermostat to the desired temperature. The burner will ignite and continue to operate as long as there is sufficient water flow to satisfy both the pressure switch and the temperature control.

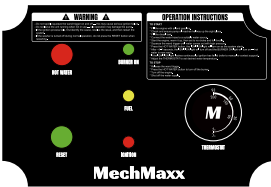

### Warning: If You Experience Ignition Failure

Do not attempt to restart the burner! Excess fuel and vapors may have accumulated, and the combustion chamber could be hot. The unit must cool down before any attempt to restart the burner can be made.

### Warning: Condensation on Coil

When cold water is being pumped through the heater coil and the burner is firing, condensation may form on the coil and drip into the burner compartment. This is especially noticeable on cold, humid days, and may give the false appearance of a leaking coil. A leaking coil or system will be evident if the pump keeps cycling with the trigger released. The pump head pressure should read 0.

### Electrically Operated Burners

-These models generate 12V from the gasoline engine to provide the necessary power for the burner. The power supply must be adequate for your specific unit. Check the data plate for your machine's specific requirements.

## 12. Pressure Adjustment

-The pressure regulator (unloader valve) is located on the pump. It controls the pressure generated by the pressure washer.

The pump is factory-set to the proper pressure. Do not attempt to adjust it — doing so may damage the pump and result in pressure loss.



### 13. Start Cleaning Operation

-You are now ready to begin cleaning. Pull the trigger on the pressure wand assembly to start the cleaning process. To stop the pressurized water, release the trigger. Do not leave the unit running when not in use to prevent unnecessary wear and damage.

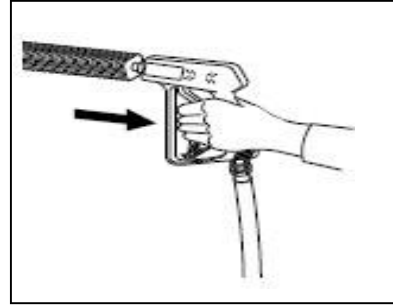
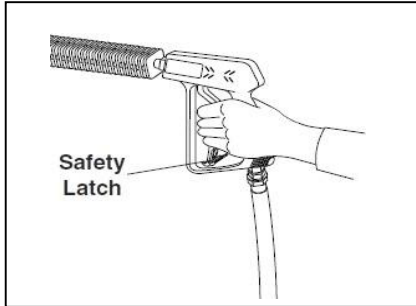

### 14. To Stop Burner Operation

-Press the HOT WATER switch again to turn off the burner. Run the pump for two minutes with the trigger gun pulled to allow the coil to cool down. Squeeze and release the trigger a second time to relieve pressure from the pump system.

### 15. Prior to Storage

-Inspect the pressure washer for any damage or required maintenance. If your machine will be exposed to cold weather, refer to the winterization instructions for the pump and coil found in this manual. If possible, do not leave the unit outside in harsh weather conditions.

### 16. Warning: Pump Damage

-Do not leave the unit running when not in use. Continuous operation when idle may cause pump damage.

---

## CHEMICAL APPLICATION

---

### Downstream Chemical Injection: Standard (Direct Drive Units) High Pressure Soap

#### NOTE:

**Do not remove the backflow preventer, as chemicals may flow back into the potable water source. For standard chemical injection, ensure the black nozzle is properly fitted at the end of the wand. The chemical injector will not function if the nozzle is not in place.**

#### 1. Chemical Preparation

-Select a detergent or chemical that best suits your cleaning task. Prepare the chemical dilution according to the manufacturer's instructions. Adjust the volume of chemical being used at the valve located on the chemical injector.

#### 2. Insert the Intake Hose

-Insert the intake hose (located on the chemical injector at the pump) into the chemical being used.

#### 3. Fit the Nozzle

-For standard units, fit the black nozzle onto the wand. For dual wand systems, turn the adjustment knob on and adjust it to the required flow rate. For high-pressure soap systems, the black nozzle is not needed—use one of the other wand nozzles.

#### 4. Apply Chemical

-To apply the chemical, engage the trigger on the pressure wand assembly. Turn the chemical injector's nipple to adjust the flow. For high-pressure soap systems, open the ball valve and engage the trigger.

#### 5. Chemical Application

-The chemical will now be applied through the pressure wand assembly. It will take 5–15 seconds for the chemical to travel to the spray nozzle. Adjust the chemical volume as needed at the chemical injector.

#### 6. Best Practices for Chemical Application

-For best results, apply the chemical from bottom to top, allowing proper penetration time before rinsing. Do not allow the chemical to dry on the surface. Rinse from bottom to top, then top to bottom to ensure thorough removal.

---

## STORAGE & WINTERIZING

---

**Procedure for Storing the Pressure Washing Unit in Freezing Temperatures.** The following procedure must be used when storing the pressure washer in temperatures below freezing:

#### 1. Drain the System

-All water must be drained or blown out using compressed air. Connect a short piece of male-fitted ½" garden hose to the female inlet on the pump.

#### 2. Prepare Anti-Freeze Solution

-Place the open end of the hose into a wide-mouthed container filled with full-strength, winter-rated windshield washer fluid or anti-freeze rated for a minimum of -40°C.

#### 3. Connect the Pressure Wand Assembly

-Attach the pressure wand assembly to the system.

#### 4. Run the System

-Start the engine and engage the trigger on the pressure gun. Operate the system until the fluid running through the system matches the color of the windshield washer fluid. Your machine is now prepared for cold weather storage.

#### 5. Disconnect and Final Steps

-Disconnect the fluid supply and blow out the system with compressed air. Cap the end of the hose to seal it.

---

## GENERAL MAINTENANCE

---

### Burner Maintenance

**NOTE: Burner repairs must only be performed by authorized and trained professionals.**

#### Oil Filter Cartridge

-Replace the oil filter cartridge every year to prevent fuel contamination and clogging of the fuel pump and nozzle.

#### Nozzle Replacement

-The nozzle should be replaced at least once a year or more frequently (e.g., twice a year) if the machine is used daily or if poor combustion is observed.

#### Final Burner Adjustments

-Fuel Pressure Adjustment: Adjust the fuel pressure to control the water temperature. To increase the output temperature, tighten the fuel pressure adjustment screw slightly. Air Band Adjustment: Adjust the air band for combustion efficiency. A combustion test kit should be used for these final adjustments. Refer to the SPECIFICATIONS chart for the correct burner oil pressure for your model. Do not exceed the specified pressure.

#### If the Burner Floods with Oil

-Run the machine with the heat on until all excess oil is burned off (this can take up to a couple of hours). If excess oil is not properly dealt with, the ceramic casing may absorb it, creating a fire hazard. DO NOT leave the machine unattended while it is flooded with oil.

#### General Maintenance and Care

-Winterizing the Water Heater. If the water heater will be exposed to freezing temperatures, winterize the system according to the procedure outlined in the Winter Pump/Coil Protection section. Alternative methods may not provide full protection. Damage from freezing is not covered under warranty.

#### Water Quality

If local water is high in mineral content, consider using a water softener. The benefits of soft water include:

- Prevents scale buildup in the heater coil.
- Cleans better with less detergent.
- Reduces streaking on painted surfaces and glass when rinsing.

### Descaling the Heater Coil

**NOTE: Descaling of the heater coil must only be done by authorized and trained professionals.**

The most effective way to acidize the coil is by using a circulation pump capable of handling acids.

-Prepare the Acid Solution: Fill a plastic container with a suitable acid diluted with water to the desired strength.

-Set Up the Circulation Pump: Connect the discharge from the circulating pump to the hot water outlet on the water heater using a suitable hose. Connect the pump inlet to the acid container with a suction hose, using the return hose to funnel the solution back into the acid container.

-Acid Circulation: As the acid dissolves the scale, it becomes neutralized. Every 5 minutes, add more acid to the container until all scale is removed from the coil.

-Flush the Coil: After descaling, thoroughly flush the coil with clean water to remove any remaining acid and residue.

## MAINTENANCE CHECKLIST

### Pump Maintenance

#### Daily:

- Check the oil level and adjust as needed.
- Inspect the quality of the oil.
- Check the pump for oil and/or water leaks.
- Clean and inspect the inlet filters.

#### Weekly:

- Inspect all fittings, components, hoses, connections, and nozzles for damage, loose parts, or leaks.  
Replace any damaged or worn parts as needed.

#### Oil Change and Component Replacement Recommendations:

- Change the pump oil after the first 50 hours of use and every 500 hours thereafter. Use SAE 85W/90 Non-Detergent Oil for this pump.
- Replace other pump components as needed.

### Gasoline Engine Maintenance

#### Daily:

- Check the oil level and adjust as needed.
- Inspect the quality of the oil.
- Inspect the air cleaner element.

#### Weekly:

- Inspect engine components for damage, loose parts, or leaks.

#### Oil Change and Component Replacement Schedule:

- Change the engine oil after the first 5 hours of use, and then every 100 hours thereafter. Use 10W-30 engine oil.
- Replace the spark plug every 100 hours.
- Change the air cleaner element every 100 hours.
- Check the fuel filters every 300 hours.
- Replace other engine components as needed.

### Ignition System Maintenance

#### 1. Electrode Setting: (See below.)

-Periodically check wiring connections. If needed, adjust the electrodes using the provided diagram.

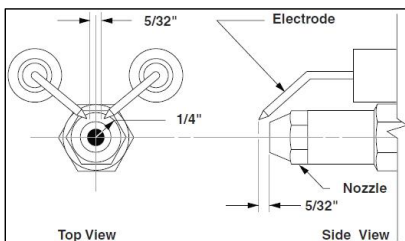

**2. Flame Detector:**

-The flame detector is a crucial component of the ignition system, as it determines whether ignition is successful. When the machine starts, stops, or fails to ignite, black smoke or soot may accumulate on the glass cover of the flame detector. If the glass cover becomes covered with soot, the flame detector will no longer function properly, and the machine will trigger an alarm. To maintain proper operation, the flame detector should be cleaned regularly. Use a soft cloth to wipe off any soot or bituminous coal from the surface.

**Cleaning Steps:**

- Lift the machine and remove the ignition.
- Clean the flame detector's surface to remove soot or bituminous coal.

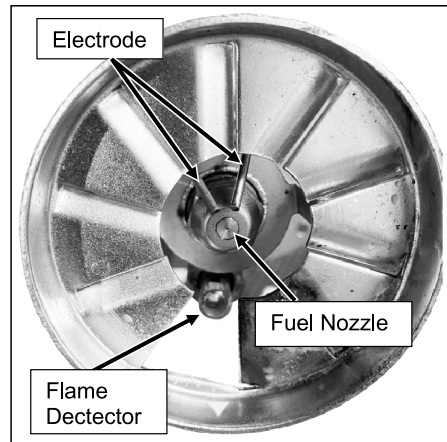

## QUICK DIAGNOSTICS AND SOLUTIONS GUIDE

PROBLEM	POSSIBLE CAUSES	SOLUTIONS
<b>PRESSURE</b>		
<b>No pressure or Very low pressure</b>	<b>Metal in oil</b>	<ul style="list-style-type: none"> <li>- Examine oil in pump to see if there is metal in oil.</li> <li>- If you find traces or pieces of metal, your pump has damaged components.</li> </ul>
	<b>Dirt in water</b>	<ul style="list-style-type: none"> <li>- Verify if there is dirt in nozzle tip or in valves in pump.</li> <li>- If nozzle is plugged, clean or replace it.</li> <li>- If valves in pump are clogged, clean valves.</li> <li>- If valves in pump are damaged or pitted, replace valves.</li> </ul>
	<b>Wrong nozzle size</b>	<ul style="list-style-type: none"> <li>- Make sure you have the right nozzle size. The black nozzle will drop pressure in order to use chemical injector and is only for soap or chemical. If you are not using soap, use a different color.</li> </ul>
<b>Pressure too high</b>	<b>Wrong nozzle size</b>	<ul style="list-style-type: none"> <li>- Make sure you have the right nozzle size.</li> </ul>
	<b>Unloader adjusted improperly or damaged</b>	<ul style="list-style-type: none"> <li>- Check pressure of pump with a pressure gauge and adjust to desired pressure.</li> <li>- If you cannot reduce pressure, replace unloader.</li> </ul>

PROBLEM	POSSIBLE CAUSES	SOLUTIONS
<b>BURNER</b>		
<b>No hot water</b>	<b>Dead battery</b>	<ul style="list-style-type: none"> <li>- Make sure your battery is fully charged.</li> <li>- If the battery's charge is not full, please replace or re-charge your battery.</li> </ul>
	<b>Damaged thermostat</b>	<ul style="list-style-type: none"> <li>- Make sure thermostat is connected properly.</li> <li>- If burner fan does not come on when you turn thermostat dial, replace thermostat.</li> </ul>
	<b>Damaged pressure switch</b>	<ul style="list-style-type: none"> <li>- Make sure pressure switch is connected properly to burner unit. Take cover off pressure switch by unscrewing the 4 screws on the front part of the switch (switch is located on pump). Without touching the contacts that conduct current, push on the little button found on the micro switch (button is located directly above the part that attaches directly into pump).</li> <li>- If burner comes on, replace pressure switch.</li> <li>- If burner does not come on, make sure there is current going through switch (consult a professional for this if you do not know how to do this properly as you can get severely injured by the electrical current connected to your machine). If current properly flows through pressure switch to burner, check ignitor.</li> </ul>
	<b>Damaged ignitor</b>	<ul style="list-style-type: none"> <li>- Please call a repair center for help to conduct tests on the ignitor.</li> <li>- If you see vapor coming out the top of the coil when you try to turn the burner on while the machine is in use, fuel is passing through the system properly but the ignitor is unable to produce a spark. Replace the ignitor.</li> <li>- If you don't see vapor, check the fuel line.</li> </ul>
	<b>Plugged filter or no fuel</b>	<ul style="list-style-type: none"> <li>- Make sure you have enough fuel in the tank.</li> <li>- If you have fuel, make sure the filter and fuel line are not plugged or damaged.</li> </ul>



PROBLEM	POSSIBLE CAUSES	SOLUTIONS
<b>IGNITION INDICATOR LIGHT</b>		
<b>Flashing</b>	<b>One time</b>	<ul style="list-style-type: none"> <li>- <b>FUEL indicator light on</b></li> <li>- Fuel is low, need to add fuel</li> <li>- Low fuel shut-off sensor stuck or faulty</li> </ul>
	<b>Two times</b>	<ul style="list-style-type: none"> <li>- <b>False flame signal</b></li> <li>- Flame detector damage (Short circuit)</li> </ul>
	<b>Three times</b>	<ul style="list-style-type: none"> <li>- <b>Not on fire</b></li> <li>- Electrode is not installed correctly</li> <li>- Ignition transformer damage</li> <li>- Flame detector damage</li> <li>- Solenoid valve not energizing</li> </ul>
	<b>Four times</b>	<ul style="list-style-type: none"> <li>- <b>Fuel supply is insufficient</b></li> <li>- Solenoid valve not energizing</li> <li>- No fuel to bleed valve, check the fuel line</li> <li>- Fuel nozzle is blocked</li> <li>- <b>Flame detector problem</b></li> <li>- Flame detector damage</li> <li>- Flame detector is covered with bituminous coal</li> </ul>

PROBLEM	POSSIBLE CAUSES	SOLUTIONS
<b>SMOKE</b>		
<b>Black Smoke</b>	<b>Inadequate combustion</b>	<ul style="list-style-type: none"> <li>- <b>Excessive fuel injection</b></li> <li>- Check nozzle diameter</li> <li>- <b>Air supply is insufficient</b></li> <li>- Check and increase engine speed</li> <li>- Check the air duct to see if any air leak</li> <li>- Check to see if the belt is loosed</li> </ul>
<b>White Smoke</b>	<b>Excessive residual fuel</b>	<ul style="list-style-type: none"> <li>- Ignition failure, machine failure</li> <li>- Check boiler inner wall, clean up residual fuel</li> </ul>



## SERVICE MANUAL

This manual is intended for technical personnel to assist in the diagnosis and repair of issues with pressure washers. This manual is not intended for use by non-technical personnel.

It is advised to always refer to competent technical personnel when repairs are advised to avoid equipment damage or potential personnel injury.

### POWER SYSTEM DIAGNOSTICS - Gas Engine Not Starting

PROBLEM	POSSIBLE CAUSE	SOLUTION
Gas motor not starting	Fuel	Check to see if proper fuel levels are maintained
	No ignition	Check ignition by removing spark plug from cylinder. If electric start, try starting using the recoil starter.
	Electric Starter/Battery	Recharge or replace battery.
	Fuse blown in key switch	18 amp engine, open key switch, replace 30 amp fuse.
Spark Plug - strong gas smell	Flooded	Wait 5 minutes before attempting to restart.
	No ignition	Check ignition by removing spark plug from cylinder. If electric start, try starting using the recoil starter.
	Bad plug	Check spark plug and replace if necessary. Carbon deposits can indicate a fouled plug or too much fuel.
Plug does not fire	Poor connection	Inspect the ignition connection.
	Bad magneto	Check the source of spark plug for engine ignition.
Bad ignition system	Poor connection	Check the source of spark for the engine ignition.
Spark Plug - no gas smell	No fuel to cylinder	Check fuel delivery from carburetor to cylinder. Check carburetor float bowl for fuel.
	Fuel line restricted	Inspect fuel line to carburetor for restrictions or clogging. Flexible line may be kinked.
	Stuck carburetor float	Unstick float
	Clogged carburetor needle valve	Unclog needle valve.
	Bad fuel pump	Replace fuel pump.

**FLUID SYSTEM DIAGNOSTICS - Flow and Pressure**

PROBLEM	POSSIBLE CAUSE	SOLUTION
No Flow	No power	Make sure pump is operating. Check drive belts and couplings, make necessary adjustments.
	Trigger gun valve	Check trigger gun, repair or replace.
	No water source	Ensure water supply is not restricted and hoses are in good repair and not kinked.
	Clogged spray nozzle	Check spray nozzle, repair or replace.
	Clogged inlet filter	Check inlet filter, repair or replace.
	Float Valve stuck (optional)	Float valves can become stuck in the "UP" position. Manually dislodge and inspect for problems.
	Faulty unloader valve	Remove and check for proper action, repair or replace.
Low pressure, adequate flow	Incorrect or no spray nozzle	Nozzle should be properly sized for the system. Low pressure indicates that the nozzle in use is too large.
	Worn spray nozzle	Replace nozzle when it shows signs of internal erosion.
	Debris in valves	Clean valves and check o-rings for pits and cracks.
	Lance on low pressure	Adjust pressure so the water flows through properly.
	Unloader is not adjusted correctly	Adjust unloader to proper level.
	Pressure gauge inaccurate	Use a new pressure gauge on a quick connect at outlet to check system pressure and replace if gauge is faulty.
	Pump packings bad	If low pressure persists, pump packings may need replaced.
Low pressure, low flow	Volume Improperly adjusted	If unit has volume adjustment, it may need readjustment
	Discharge leaks	Look for leaks on the discharge side of system.
	Downstream chemical injector (Dema)	Remove the injector and retest system. If the flow is restored, replace the injector.
	Loose drive belts	If belts do not have proper deflection, replace them.
	Pump not running at rated speed	Check engine throttle and see that the motor is rated for the same speed as the pump.
	Stripped pump drive coupling	Inspect coupling and repair or replace.
	Defective easy start valve (optional)	Check the start or throttle-back valve for proper operation.
	Malfunctioning motor or gear	Ensure that the motor or engine is working properly
	Unloader stuck in bypass	Piston assembly may be stuck or fouled
Low pressure, low flow -Bogs	Outlet restriction	Build up can restrict flow. If water is not flowing freely, flush with garden hose to isolate the clog or restriction.
	Clogged nozzle	Distorted spray pattern can indicate a clogged nozzle.
	Nozzle too small	Ensure nozzle is proper size for the system.
	Hose restriction	Correct any kinks or restrictions. Replace crushed hoses.



PROBLEM	POSSIBLE CAUSE	SOLUTION
Excessive pressure	Debris in the system	Debris can lodge in the discharge side of the system (valves, fittings, injectors, filters) Flushing with water may correct it.
	Small spray nozzle	Nozzle must be properly sized for the rated flow and pressure. Reset unloader or pressure relief if nozzle size is changed.
	Faulty pressure gauge	Check the pressure gauge using a properly calibrated pressure gauge on quick connects at the equipment outlet.
	Improperly adjusted unloader	Adjust to the proper pressure using pressure gauge.
	Faulty unloader	Check the unloader action. If it is not working properly, it may need repaired or replaced.
Pump chatters, cavitation, vibration	Air in system	Inspect places where air can enter the system. i.e. fittings, hose, connections etc.
	Chemical line not submerged	If the chemical valve is on, ensure that the chemical line is fully submerged in the chemical
	Inlet line restricted	All inlet connections should be snug and not kinked to reduce the chances of pump starvation.
	Inadequate water supply	Water supply to the system must meet or exceed the rated flow (GPM) on the serial number plate. Faucet must be completely opened or water above the tank outlet in a gravity fed system.
	Float valve stuck (optional)	If float valve is stuck in the up position, water can not enter the float tank. Unstick valve if possible or replace if necessary.
	Turbulence in float tank (optional)	Excessive turbulence allows the pump to draw air into the system. Correct excessive turbulence.
	Inlet or inlet strainer clogged	Regularly clean the inlet and inlet strainer to keep debris from entering the float tank
	Water supply too hot	Inlet temperature should not exceed 140F - 160F range.
Inlet line vibrates	Air in system	Inspect places where air can enter the system, i.e.; fittings, hose, connections etc.
	Debris in inlet check valves	If there is no float tank and the outlet line does not vibrate, the inlet check valve may be clogged. Remove debris. Check o-rings under valves.
Outlet line vibrates	Air in system	Inspect places where air can enter the system, i.e.; fittings, hose, connections etc.
	Debris in inlet check valves	If there is no float tank and the outlet line does not vibrate, the inlet check valve may be clogged. Remove debris.
	Pump packing bad	If they show signs of wear or damage, replace them.
Inlet and outlet lines vibrate	Inlet and outlet check valves fouled	Look for the source of debris in the inlet and discharge check valves and remove.



**FLUID SYSTEM DIAGNOSTICS -Unloader**

PROBLEM	POSSIBLE CAUSE	SOLUTION
Very low or no flow	Unloader stuck in bypass	Isolate the flow problem. If it occurs before the unloader discharge point, check the piston assembly to see if it is fouled or stuck in bypass mode.
Unloader will not unload	Debris in unloader	Take bottom nut off unloader, identify ball, spring and seat. Clean out any debris and
	Sever leak on the outlet of unit	Check for leaks and repair.
Unloader (flow) cycles with system under pressure	Improper flow	Any variation in flow from what the orifice is sized can cause cycling. System must produce the rated flow constantly.
	Nozzle too small	A nozzle that is too small can cause the flow to be reduced.
	Nozzle clogged	A distorted spray pattern indicates a clogged nozzle.
	Improper unloader orifice	The systems rated output should indicate the proper sized orifice for your system.
	Unloader orifice clogged	Check the orifice for clogs and clear out any debris.
	Injector orifice clogged	If the system has a Venturi injector downstream of the unloader, check the orifice for clogs.
	Other downstream restriction	Scale buildup can restrict flow. Check; controls, valves, switches, trigger gun, and lance. Descale as necessary and begin preventive maintenance program for scale prevention.
	Pump not delivering the rated pressure	See low pressure or low flow diagnostics.
	High water supply pressure	Check inlet water supply for excessive pressure.
Unloader (flow) cycles with system in bypass	No restrictions on the unloader	Check unloader bypass port to see if a flow restrictor is properly installed. Install one if none is present.
	Downstream leakage (excessive)	Causes the unloader to sense a continuing flow and divert it to the closed gun. Repair or replace.
	Accumulator downstream (option)	Remove the accumulator from the system.
Unloader (pressure) produces smooth flow & low volume	Unloader adjusted too low	Adjust the unloader using the pressure gauge for the correct pressure.
	Spray nozzle clogged	A distorted spray pattern indicates a clogged nozzle.
	Spray nozzle too small	A small nozzle causes a reduced flow and cycling may result.
	Injector orifice blocked	If the system has a Venturi injector downstream of the unloader, check the orifice for clogs.
	System not delivering rated flow	See flowdiagnostics.



PROBLEM	POSSIBLE CAUSE	SOLUTION
Unloader (flow) produces smooth flow & low volume	Unloader adjusted too low	Adjust unloader and regulator until proper pressure is achieved.
	Unloader valve stuck in bypass	If unloader is sticking, repair or replace as necessary.
	Restriction in system	Downstream restrictions can cause a reduction in flow. Check; controls, valves, switches, trigger gun, and lance. Descale as necessary and begin preventive maintenance program for scale prevention.
Unloader (pressure) produces low flow and normal pressure	Unloader adjusted too low	If the unloader is diverting flow to bypass it may be adjusted too low, readjust as necessary.
	Spray nozzle too large	Ensure the proper nozzle is installed on system.
	Internal nozzle erosion	The number of hours of usage can give you a clue to the extent of the wear. If in doubt, change
	Insufficient pump pressure	Check pump seals and packings and tighten drive belts.
Unloader (flow) produces low flow & normal pressure	Unloader adjusted too low	If unloader is diverting flow to bypass, readjust using the pressure gauge.
	Nozzle too large	Ensure the proper sized nozzle is being used.
Unloader (pressure) leaks from main spring or adjusting bolt	Shaft O-ring in valve body worn	Check O-rings for wear or damage and replace as necessary.
Unloader (flow) pressure increases when trigger released	Unloader piston stuck or frozen	Check unloader shaft for proper action. Unstick piston and shaft or replace unloader.
	Bypass port clogged or restricted	Ensure that unloader bypass port is not clogged
	Excessive tension on main spring	If tension is incorrect, adjust or replace as necessary.
Unloader (flow) leaks water around adjusting bolt	Sleeve O-ring worn	Check O-rings for wear or damage and replace as necessary.



**FLUID SYSTEM DIAGNOSTICS- Leaking ANY LEAKS SHOULD BE REPAIRED ASAP TO PREVENT DAMAGE TO THE SYSTEM.**

PROBLEM	POSSIBLE CAUSE	SOLUTION
From inlet	Garden hose washer	Ensure the washer is present and in good condition.
From low pressure (inlet) line fittings	Loose clamps or connections	Low pressure line should be properly sealed on barb and tightly clamped.
From float tank(option)	Float tank full of water or stuck	If float is not floating above water, check the float to see if it has filled up with water. If necessary, drain and seal.
From quick connects	Bad o-rings	If quick connect o-ring shows wear or damage, replace it.
From pump	Bad packing	If the seal leak is detected under the pump manifold, packing may be worn and in need of replacement.
From trigger gun	Bad rod o-ring	If o-rings show wear or damage, they may need replaced.
	Stripped connectors	Physical damage may not be apparent, but unseen warping from freezing or extreme pressure can still cause leakage.
From nozzle	Weep gun (optional)	If a weep gun has been installed, check the gun valve seat to ensure it is functioning properly.
	Damage gun valve ball or seat	Inspect trigger gun valve assembly for damage or ware to ball or seat. Lodged debris can stop valve from closing. Repair with kit or replace.
From unloader	Bad o-rings oe selas	If quick connect o-ring shows wear, damage or improper seating.
From variable pressure Lance(option)	Bad o-rings at adjusting knob	Inspect o-rings for ware or damage and replace as necessary.
Unloader will not unload	Debris in unloader	Take bottom nut off unloader, identify ball, spring and seat. Clean out any debris and reassemble.
	Sever leak on the outlet of unit	Check for leaks and repair.
From pressure relief valve	System over pressure	See pressure and flow diagnostics to find the cause of the excessive pressure and correct it.
	Clogged nozzle	Spray pattern will be distorted if nozzle is clogged, clean out.
	Trigger gun valve not working	If trigger gun valve action is not correct, repair or replace.
	Excessive pressure spike	If water spurts from valve when trigger is released, check unloader adjustment. Pressure spike should be below the level where pressure relief valve is activated.
	Wear or damage to ball or seal	Inspect ball and seal for damage and adjust as necessary.
	Improper relief valve adjustment	Adjust valve properly.



**FLUID SYSTEM DIAGNOSTICS - Trigger Gun/Spray Nozzle**

PROBLEM	POSSIBLE CAUSE	SOLUTION
No nozzle flow from nozzle when trigger depressed.	Broken piston rod in trigger gun	If water flows through discharge hose without gun, check trigger gun valve piston rod and replace if necessary.
	Missing metal insert in trigger gun (European style gun)	Inspect to assure insert is in place.
	Blockage in system past gun	Check nozzle or spray accessory for blockage and clear it.
Excess pressure when trigger gun is released	Excessive pressure spikes	After unloader increases pressure to a maximum, further adjustment will only increase the pressure spikes. Re-adjust.
Flow not stopping when trigger gun released	Broken return spring on trigger gun	If trigger action is too loose, return spring may need replaced.
	Debris in gun valve	Debris in gun valve can stop piston return. Clear debris.
Trigger action sticks	Keeper plug too tight	It may be possible to loosen plug slightly without leakage but it will likely need replaced.
Trigger gun leaks	Worn or bad o-ring	Check trigger gun o-rings for wear or damage and replace.
	Stripped or loose connections	Physical damage may not be apparent but unseen warping from freezing or severe overpressure may still cause leaking.
No chemical	Chemical valve closed Black nozzle	Open chemical valve. If it chatters with no chemical delivery, air is being drawn from the upstream side of the pump. Check fittings, connections and ensure the inlet line is fully submerged into the chemical jug.
	Chemical dried up in the injector	Inspect and clean as necessary.
	Chemical foot strainer clogged	May be a strainer or check valve. Ensure that the ball is not stuck or clogged.
	Chemical line kinked	Chemical line kinking or binding prevents chemical delivery.
	Chemical line too long	An overly long chemical line can prevent the pump from drawing chemical into the system. Try installing a shorter line.
	Chemical too dilute	Verify chemical strength.
	No adjustment for low pressure	Downstream injectors only - Low pressure is required for most injectors to draw chemical. If no adjuster exists it may need low pressure spray nozzle installed on the lance.
	Incorrect injector orifice	If not properly sized for the systems rated output, chemical delivery problems will result. Check serial plate for specs.
Excessive chemical	Valve improperly adjusted, check knob on injector	To properly adjust, a chemical flow meter may be used to precisely measure chemical flow.
	Chemical dilution too strong	Verify chemical strength.



PROBLEM	POSSIBLE CAUSE	SOLUTION
Spray pattern irregular	Clogged nozzle	Spray pattern will be distorted if nozzle is clogged.
Volume proper, pressure low	Nozzle too large	Ensure that the nozzle is sized properly for the system
	Internal nozzle wear	A loss of pressure may result from gradual nozzle wear. Replace a nozzle of correct size.
Pressure proper, volume low	Clogged nozzle	Spray pattern will be distorted if nozzle is clogged. Check nozzle for clogging if the unit has a pressure unloader.

**BOILER SYSTEM DIAGNOSTICS - Oil Burner Will Not Fire**

PROBLEM	POSSIBLE CAUSE	SOLUTION
Not reaching rated pressure flow	Not activating boiler controls	Correct the fluid problem first - See fluid systems diagnostics
Thermostat on low setting	Thermostat set too low	Set thermostat to an output temperature requiring heating.
No or low fuel in tank	Burner not getting adequate fuel	Check fuel and bring to proper levels. Inspect fuel tank for water or debris.
	Low fuel shut-off control activated.	Full featured equipment may have a shut off if fuel is low.
No air movement through stack	No air being supplied	Ensure that the blower is working and that the air band or damper is properly adjusted and in good repair.
Fuel in the fuel tank	Contaminated fuel in the tank	Ensure that the proper clean fuel is being used. If not, siphon any debris or water from the tank.
	Improper fuel in the tank	If the improper fuel is found in the tank, drain and rinse the tank, then fill with proper fuel.
	Low fuel shut-off sensor stuck or faulty	Check the sensor. The assembly may need to be removed to un-stick the float or to replace it completely.
Water in the fuel filter bowl	Water in fuel supply	Drain water from the tank promptly to prevent rusting. If fuel delivery problems persist, check the fuel pump for rust.
Debris in the fuel filter bowl	Clogged strainer	If the fuel strainer or in-line filter is clogged, clean or replace.
	Clogged fuel nozzle	Replace if there is any evidence of clogging or debris.
	Clogged fuel line	Check lines for clogging and clear if necessary.
Water comes out drain at bottom of tank	Water in fuel supply	Check only if no fuel in the filter bowl - Drain the tank and check for rust. If problem persists, fuel pump should be checked for rust.
Cannot smell or see fuel at stack	No fuel being supplied	Check fuel delivery and correct any problems.



PROBLEM	POSSIBLE CAUSE	SOLUTION
No fuel to bleed valve	Air leak to pump	Ensure that air is not entering through the lines or connections.
	Broken fuel line	Ensure that the fuel line is connected and is not broken/punctured.
	Clogged fuel filter	Check any clogging that exists in the fuel filter
	Clogged fuel inlet line	Check any clogging that exists in the fuel inlet line.
	Frozen fuel pump	If the fuel pump is frozen it will need replaced.
	Broken fuel pump coupling	Check pump coupling if direct or belt driven. Replace or tighten or replace the drive belts if needed.
Steady fuel flow at bleed valve but none in combustion chamber	Solenoid valve not energizing	Remove the solenoid cover and place blade of an insulated screwdriver in the coil with the system operating in hot water mode. A good working solenoid will hold the screwdriver in the solenoid. If not it may need replaced.
		Oil pump may have debris, replace as necessary.
Boiler controls activating	Solenoid valve coil not energizing	If boiler controls work properly, the pressure or vacuum on the fuel pump may be misadjusted. Check solenoid coil again.
Solenoid valve energizing	Debris in internal fuel pump valve	Check for clogging in the solenoid valve inside fuel pump.
	Fuel nozzle clogged	Check fuel nozzle for clogging and clear if necessary.
	Restriction in fuel outlet line	Check fuel line from pump to burner for any restriction.
	Fuel pump piston frozen closed	Check piston in fuel pump to see if it will travel. Free piston or replace fuel pump.
Air and fuel flow proper	No power reaching transformer	Ensure the proper voltage is reaching the ignition transformer with a volt meter.
	Ignition transformer bad	Using a volt meter, ensure that the transformer is supplying the proper voltage.
	Electrode gap improperly set	Check the gap and readjust if necessary, taking care that the proper distance is maintained from the fuel nozzle.
	Electrode caps cracked	Down fired, multi-pass boiler systems have a cap on the top of each electrode. Examine caps for cracks or carbon build-up and replace if these problems are evident.
	Electrode wires loose or damaged	Applies to down fired, multi-pass boiler systems - Check the wire to each electrode to ensure there is a good connection.
	Electrodes arcing to fuel lines	Electrodes should not be arcing to fuel lines or nozzle. Check electrode for cracking or carbon build-up.
	Transformer bus bars not lining up	Applies to gun type burners - Bus bars on the transformer should line up and connect properly with the electrode terminals



PROBLEM	POSSIBLE CAUSE	SOLUTION
Burner or electrode assembly fires when removed from housing	Improper air delivery	Check air delivery to combustion chamber. Down fired; check air damper and air bag. Gun type; Check air bands.
Ignites with air bands closed down	Excessive electrode gap	Ensure electrode gap is properly set.
Ignites with airbands opened up	Choked down	Open air bands to proper setting.

**BOILER SYSTEM DIAGNOSTICS Water Output Temperature Too Low**

PROBLEM	POSSIBLE CAUSE	SOLUTION
Burner firing normally but with outlet temp lower than rated	Thermostat set too low	Set the thermostat to proper output temperature.
Burner firing constantly	Inlet water too cold	If inlet water is freezing to the touch, the boiler may not be able to reach desired temperature increase. Use a water supply with a higher temperature.
	Sooting	Soot build up on the coil can keep the water from reaching the desired If inlet water is freezing to the touch, the boiler may not be able to reach the desired temperature increase. Use a water supply
	Scaling	The outlet fitting to the hose can get scale build-up and reduce heat exchange. Descale and prevent further build-up.

**BOILER SYSTEM DIAGNOSTICS - Boiler Controls**

PROBLEM	POSSIBLE CAUSE	SOLUTION
No voltage solenoid	Boiler control or electrical problem	A multimeter can be used to check continuity through controls and pinpoint the problem areas.
Solenoid coil doesn't energize	Bad connection to solenoid coil	Electrical connections to solenoid valve coil should be tight and not corroded.
	Coil bad	Check to see if fuel solenoid will energize when the proper voltage is applied. Solenoid may need replacing.
	Boiler control not activating properly	If coil energizes when proper voltage is applied, check boiler controls.
Solenoid coil energizes	Problem occurring elsewhere	If solenoid valve coil energizes when the cleaner is operating in hot water the problem is elsewhere. Check the air/fuel delivery.



**BOILER SYSTEM DIAGNOSTICS - Pressure Switch**

PROBLEM	POSSIBLE CAUSE	SOLUTION
Switch activates when pressure is reached but boiler not firing	Control not flowing through switch	A multimeter can indicate if the proper voltage flows through the boiler side of the switch. If not the switch may not need replaced.
	Switch improperly wired	Switch may be improperly wired for its function.
	Switch bad	If wiring is proper and still no current flow when activated, switch may need replacement.
Switch does not activate	Plunger fouled or stuck	Check pressure plunger to see if it will travel freely. If not, the passage may need cleared.
	Plunger not moving far enough	Check to see if the plunger is traveling far enough to depress the microswitch. Adjust if necessary.
Switch activated manually	Current not flowing through switch	If switch activates manually but boiler does not fire, current may not be flowing through. The switch may need replacing.
	Microswitch not properly adjusted	Microswitch may need readjustment so plunger can trip in.
	Switch bad	Replace switch with another one.
	Problem elsewhere in the system.	If switch works manually and current is flowing properly, the problem is elsewhere. Try other boiler diagnostics.

**BOILER SYSTEM DIAGNOSTICS - Vacuum Switch - Optional**

PROBLEM	POSSIBLE CAUSE	SOLUTION
Switch activated manually	Improper diaphragm movement	Replace switch if improper diaphragm movement is detected.
	Low water flow	Correct problems related to inadequate water flow.
	Air leak in or punctured diaphragm	Replace vacuum switch if diaphragm shows an air leak or hole.
Switch shows continuity when activated	Problem elsewhere insystem	If vacuum switch works properly, continue with other boiler control diagnostics.
Switch does not shows continuity when activated	Switch contact bad	Replace switch with another one.



**BOILER SYSTEM DIAGNOSTICS - Thermostat**

PROBLEM	POSSIBLE CAUSE	SOLUTION
Thermostat set improperly	Thermostat set too low	Set thermostat properly and ensure connections are not loose or corroded.
Boiler fires when thermostat jumped, but will not fire with thermostat in circuit	Thermostat bad	Replace Thermostat.
Boiler will not fire when thermostat jumped	Problem elsewhere in system	Continue with boiler control diagnostics. If boiler still does not fire, the thermostat may need replaced.

**BOILER SYSTEM DIAGNOSTICS - High Temperature Limit**

PROBLEM	POSSIBLE CAUSE	SOLUTION
Electrical continuity through switch	Connections loose or corroded	Check connections to high temperature limit switch to ensure that they are not loose or corroded.
	Problem elsewhere in system	If there is continuity through the switch but the boiler still does not fire, there is a problem elsewhere in the system. Continue with boiler control diagnostics.
No continuity through switch	Switch bad	Replace switch.

**BOILER SYSTEM DIAGNOSTICS - Low Fuel Shut-Off**

PROBLEM	POSSIBLE CAUSE	SOLUTION
Fuel level low	Switch may be operating properly	Add fuel and retest.
Fuel level proper	Level sensor stuck	Check level sensor for proper movement. Clear, repair, or replace sensor assembly.
	Reed switch bad	Check level sensor for proper action. Replace switch if needed.

**WIRING DIAGRAMS**

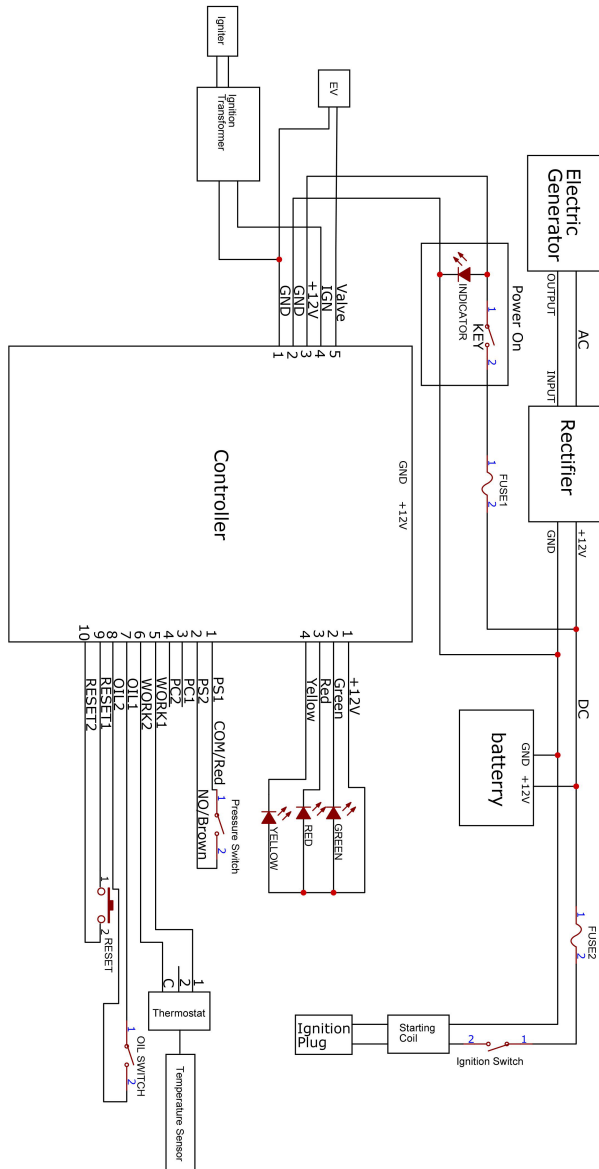

**Model: HPW40H, HPW40K, HPW40D**



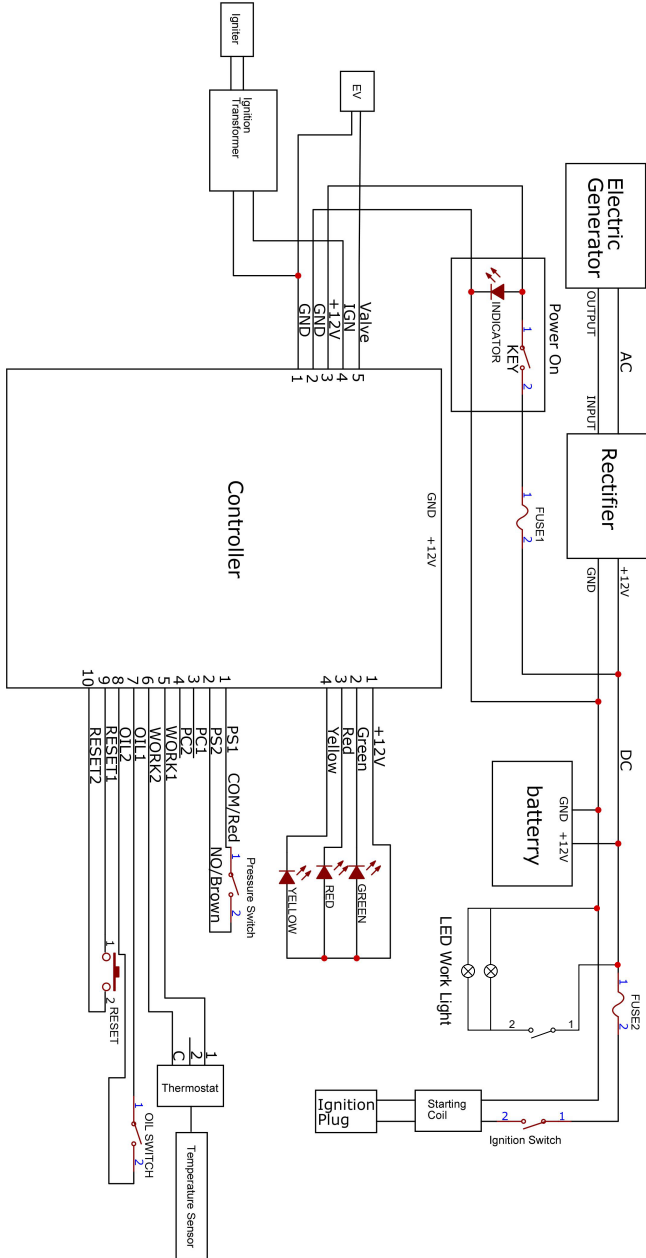

Model: HPW40HT, HPW40HBT, HPW40DT, HPW40DBT, HPW40KT, HPW40KBT

**PARTS DIAGRAMS**

**HPW40H / HPW40K / HPW40D**

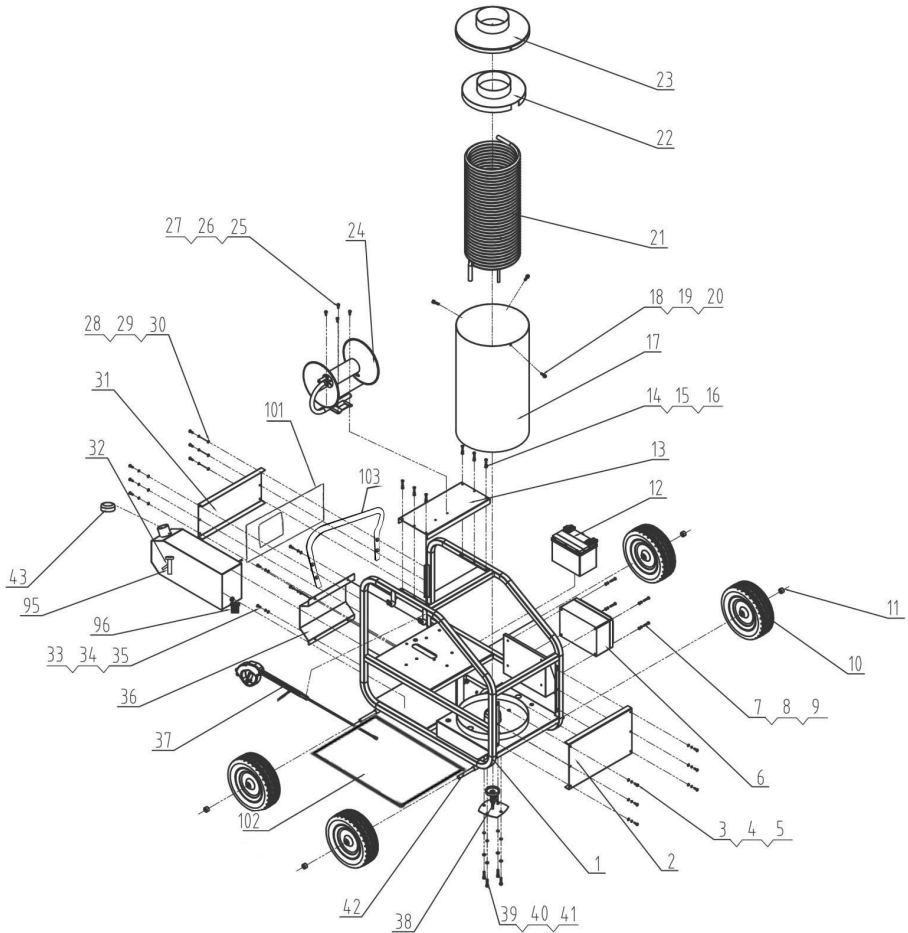

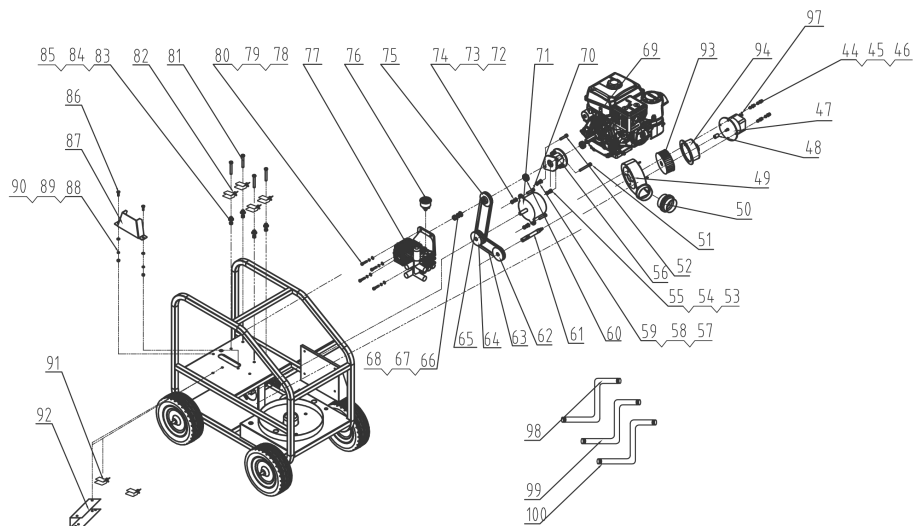

## PARTS LIST

Part #	Description	Qty.	Part #	Description	Qty.
1	Main frame	1	45	Washer M8	4
2	Right panel	1	46	Spring washer	4
3	Washer M6	6	47	Oil pump	1
4	Spring washer	6	48	Connect rod	1
5	Screw M6*20	6	49	Fan's cover	1
6	Control box	1	50	Bellows	1
7	Washer M6	4	51	Screw M10*70	1
8	Spring washer	4	52	Screw M10*35	1
9	Screw M6*30	4	53	Screw M8*35	4
10	Wheel 13"	4	54	Washer M8	4
11	shock pad of the wheel	4	55	Spring washer	4
12	Battery 12V	1	56	Cast iron	1
13	Cover panel	1	57	Washer M8	2
14	Washer M6	6	58	Spring washer	2
15	Spring washer	6	59	Nut M8	2
16	Screw M6*20	6	60	Bearing	2
17	Heater cover	1	61	Axis	1
18	Washer M6	3	62	Pulley 1	1
19	Spring washer	3	63	Belt 1	1
20	Screw M6*20	3	64	Pulley 2	1
21	Heater coil	1	65	Belt 2	1
22	Heater inside cover	1	66	Washer M10	1
23	Heater outside cover	1	67	Spring washer	1
24	Hose reel	1	68	Nut M10	1
25	Washer M6	4	69	Gasoline engine	1
26	Spring washer	4	70	Screw M8*35	2
27	Screw M6*20	4	71	Alternator	1
28	Washer M6	6	72	Washer M8	1
29	Spring washer	6	73	Spring washer	2
30	Screw M6*20	6	74	Nut M8	2
31	Left panel	1	75	Pulley 3	1
32	Diesel tank	1	76	Pressure gauge	1
33	Washer M6	4	77	Pressure pump	1
34	Spring washer	4	78	Screw M8*35	4
35	Screw M6*30	4	79	Washer	4
36	Bottom panel	1	80	Spring washer	4
37	High pressure gun	1	81	Screw M10*40	4
38	Ignition disc/ Frame detector	1	82	Shock absorber	4
39	Washer M8	4	83	Screw M10*20	4
40	Spring washer	4	84	Spring washer	4
41	Screw M8*35	4	85	Nut M10	4
42	Wheel axis	2	86	Screw M8*25	2
43	Cover of diesel tank	1	87	Belt's cover	1
44	Screw M8*35	4	88	Washer M8	1

Part #	Description	Qty.
89	Spring washer	2
90	Nut M8	2
91	Shock absorber	2
92	Holder	2
93	Fan wheel	2
94	Fan cover	1
95	liquid level switch	1
96	Diesel filter cup	1
97	Solenoid valve	1
98	pressure hose 50cm	1
99	pressure hose 70cm	1
100	pressure hose 15m	1
101	plate	1
102	Shield	1
103	Handle	1

**PARTS DIAGRAMS**

**HPW40HT, HPW40HBT, HPW40KT, HPW40KBT, HPW40DT, HPW40DBT**

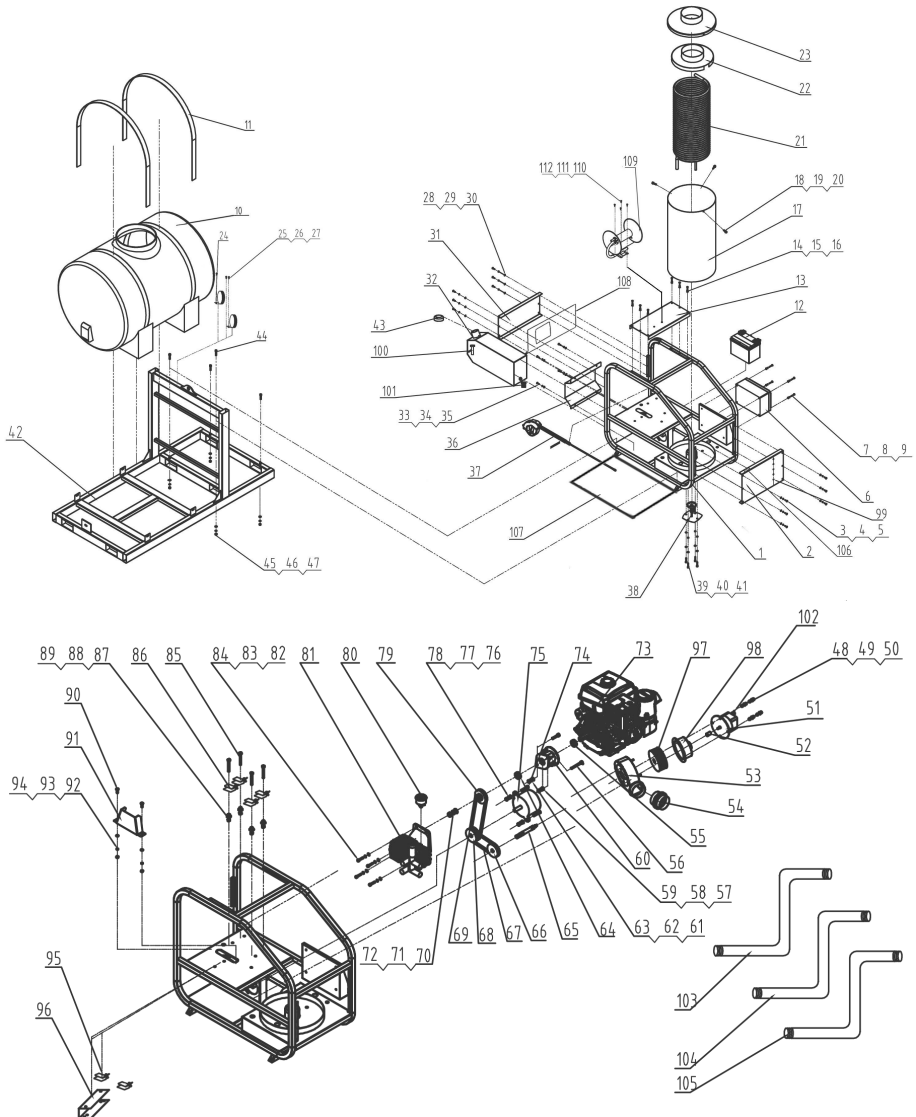

## PARTS LIST

Part #	Description	Qty.	Part #	Description	Qty.
1	Main frame	1	45	Washer M12	4
2	Right panel	1	46	Spring washer	4
3	Washer M6	6	47	Nuts M12	4
4	Spring washer	6	48	Screw M8*35	4
5	Screw M6*20	6	49	Washer	4
6	Control box	1	50	Spring washer	4
7	Washer M6	4	51	Oil pump	4
8	Spring washer	4	52	Connect rod	1
9	Screw M6*30	4	53	Fan's cover	1
10	Water tank	1	54	Bellows	1
11	Ratchet tie down	2	55	Screw M10*35	1
12	Battery 12V	1	56	Screw M10*70	1
13	Cover panel	1	57	Screw M8*35	1
14	Washer M6	6	58	Washer M10	2
15	Spring washer	6	59	Spring washer	2
16	Screw M6*20	6	60	Cast iron	2
17	Heater cover	4	61	Washer	2
18	Washer M6	3	62	Spring washer	1
19	Spring washer	3	63	Nut M8	1
20	Screw M6*20	3	64	Bearing	1
21	Heater coil	1	65	Axis	1
22	Heater inside cover	1	66	Pulley 1	1
23	Heater outside cover	1	67	Belt 1	1
24	LED work light	2	68	Pulley 2	1
25	Washer M6	4	69	Belt 2	1
26	Spring washer	4	70	Washer	1
27	Screw M6*20	4	71	Spring washer	1
28	Washer M6	6	72	Nut	1
29	Spring washer	6	73	Gasoline engine	1
30	Screw M6*20	6	74	Screw M8*35	2
31	Left panel	1	75	Alternator	1
32	Diesel tank	1	76	Washer	2
33	Washer M6	4	77	Spring washer	2
34	Spring washer	4	78	Nut M10	2
35	Screw M6*30	4	79	Pulley 3	1
36	Bottom panel	1	80	Pressure gauge	1
37	High pressure gun	1	81	Pressure pump	1
38	Ignition disc/ Frame detector	1	82	Screw M8*35	4
39	Washer M8	4	83	Washer M8	4
40	Spring washer	4	84	Spring washer	4
41	Screw M8*35	4	85	Screw M10*40	4
42	Base welder	2	86	Shock absorber	4
43	Cover of diesel tank	1	87	Screw M10*20	4
44	Screw M12*45	4	88	Spring washer	4

Part #	Description	Qty.
89	Nut M10	4
90	Screw M8*25	2
91	Belt's Cover	1
92	Washer M8	1
93	Spring washer	2
94	Nut M10	2
95	Shock absorber	2
96	holder	2
97	Fan wheel	2
98	Fan cover	2
99	Nozzle	1
100	liquid level switch	1
101	Diesel filter cup	1
102	Solenoid valve	5
103	Water hose 70cm	1
104	pressure hose 70cm	1
105	pressure hose 15m	1
106	LED work light switch	1
107	Shield	1
108	Plate	1
109	Hose reel	1
110	Spring washer	1
111	Screw M6*20	1
112	Washer M6	1

PUMP DIAGRAMS

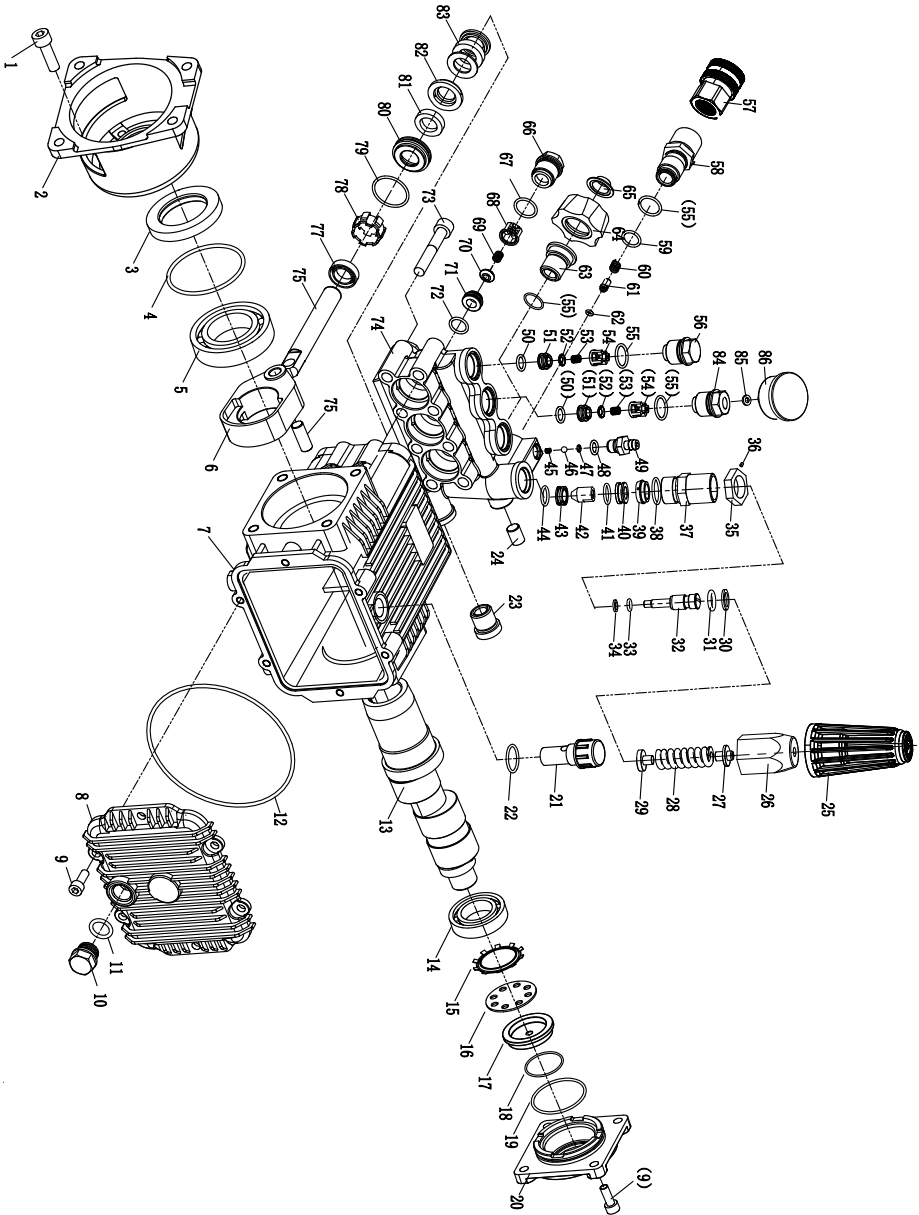

## PARTS LIST

Part #	Description	Qty.	Part #	Description	Qty.
1	Screw M8x25-8.8 grade	4	45	Injector liquid spring	1
2	Connector flange	1	46	Steel ball Ø3/16	1
3	Oil seal38*58*8	1	47	O-ring 3.68*1.78	1
4	O-ring63*2.65	1	48	O-ring 7.65*1.78	1
5	Ball Bearing 6008	1	49	Injector	1
6	Connecting rod	3	50	O-ring 9*1.8 (80 degree)	3
7	Housing	1	51	Valve seat	3
8	Back cover	1	52	Valve plate	3
9	Screw M6*16-8.8 grade	1	53	Valve spring	3
10	Oil drain plug	1	54	Valve cover	3
11	O-ring 13.2*2.65	1	55	O-ring 15*1.8 (90 degree)	5
12	O-ring 112*2.65	1	56	Bulkhead	2
13	Crank shaft	10	57	NPT3/8 quick connector	3
14	Ball Bearing 6304	1	58	Outlet connector	1
15	Jump ring	1	59	O-ring 12.5*1.8 (90 degree)	3
16	Oil Window gasket	1	60	Check Valve spring	1
17	Oil Window	1	61	Check Valve core	1
18	O-ring 47.5*1.8	1	62	O-ring 4.5*2.65 (90 degree)	1
19	O-ring 32.5*2.66	1	63	Inlet connector	1
20	End Cap	1	64	Nut(brass)	1
21	Venting plug	1	65	Inlet filter	1
22	O-ring 13.2*1.8	1	66	Inlet valve plug head	3
23	R 3/8 plug-8.8 grade	1	67	O-ring 14*1.8 (90 degree)	3
24	R 1/8 plug-8.8 grade	1	68	Valve cover	3
25	Pressure adjusting handle	1	69	Valve spring	3
26	Valve cover	1	70	Valve plate	3
27	Spring washer	1	71	Valve seat	3
28	Pressure adjusting spring	1	72	O-ring 11.8*1.8 (90 degree)	3
29	Spring cover	1	73	Screw M8*55-12. grade	8
30	Back-up ring 10.8*15.55*1.5	1	74	Pump head	1
31	O-ring 10.6*2.65 90 degree	1	75	Cylindrical pin 9*23	3
32	Valve core	1	76	Piston	3
33	Back-up ring 6*9*1.25	1	77	Reciprocating oil	3
34	O-ring 6*1.8 90 degree	1	78	Positioning sleeve	3
35	Limit washer	1	79	O-ring 25.8*1.8 (80 degree)	3
36	Set screws M4*4	1	80	Secondary seal seat	3
37	Valve body	1	81	Secondary seal 14*21*5.5	3
38	O-ring 17*1.8 90 degree	1	82	Water seal seat	3
39	Support	1	83	Water seal seat (PARKER)	3
40	Lower seat	1	84	Pressure gauge connector	1
41	O-ring 12.5*1.8 (90 degree)	1	85	Plastic washer 6*12*2	2
42	Valve core head	1	86	Pressure gauge	1
43	Conical valve seat	1			
44	O-ring 10*1.8 (90 degree)	1			

# ***MechMaxx***

[info@mechmaxx.com](mailto:info@mechmaxx.com)