



**DRAPER**<sup>®</sup>

230V 150mm/200mm

# HEAVY DUTY BENCH GRINDER

02519, 02520



These instructions accompanying the product are the original instructions. This document is part of the product, keep it for the life of the product passing it on to any subsequent holder of the product. Read all these instructions before assembling, operating or maintaining this product.

This manual has been compiled by Draper Tools describing the purpose for which the product has been designed, and contains all the necessary information to ensure its correct and safe use. By following all the general safety instructions contained in this manual, it will ensure both product and operator safety, together with longer life of the product itself.

All photographs and drawings in this manual are supplied by Draper Tools to help illustrate the operation of the product.

Whilst every effort has been made to ensure the accuracy of information contained in this manual, the Draper Tools policy of continuous improvement determines the right to make modifications without prior warning.

# 1. TITLE PAGE

---

## 1.1 INTRODUCTION:

**USER MANUAL FOR: 230V 150mm/200mm Heavy Duty Bench Grinder**

**Stock No's: 29620, 29621**

**Part No's: GHD150, GHD200**

## 1.2 REVISIONS:

---

**Date first published September 2001.**

---

**Date first revised July 2021.**

---

---

As our user manuals are continually updated, users should make sure that they use the very latest version.

**Downloads are available from:** <http://drapertools.com/manuals>

Draper Tools Limited  
Hursley Road  
Chandler's Ford  
Eastleigh  
Hampshire  
SO53 1YF  
UK

Draper Tools Limited  
Oude Graaf 8  
6002 NL  
WEERT  
Netherlands

**Website:** [drapertools.com](http://drapertools.com)

**Product Help Line:** +44 (0) 23 8049 4344

**General Fax:** +44 (0) 23 8026 0784

## 1.3 UNDERSTANDING THIS MANUALS SAFETY CONTENT:

**Warning!** – Information that draws attention to the risk of injury or death.

**Important** – Information that draws attention to the risk of damage to the product or surroundings.

## 1.4 COPYRIGHT © NOTICE:

Copyright © Draper Tools Limited.

Permission is granted to reproduce this publication for personal and educational use only. Commercial copying, redistribution, hiring or lending is prohibited.

No part of this publication may be stored in a retrieval system or transmitted in any other form or means without written permission from Draper Tools Limited.

In all cases this copyright notice must remain intact.

# 2. CONTENTS

---

## 2.1 TABLE OF CONTENTS

<b>1. TITLE PAGE</b>	
1.1 INTRODUCTION.....	2
1.2 REVISIONS.....	2
1.3 UNDERSTANDING THIS MANUALS SAFETY CONTENT .....	2
1.4 COPYRIGHT © NOTICE.....	2
<b>2. CONTENTS</b>	
2.1 TABLE OF CONTENTS .....	3
<b>3. WARRANTY</b>	
3.1 WARRANTY.....	4
<b>4. INTRODUCTION</b>	
4.1 SCOPE.....	5
4.2 SPECIFICATION.....	5
4.3 HANDLING AND STORAGE.....	5
<b>5. HEALTH AND SAFETY INFORMATION</b>	
5.1 GENERAL SAFETY INSTRUCTIONS FOR POWER TOOL USE .....	6
5.2 SPECIFIC SAFETY INSTRUCTION FOR BENCH GRINDERS.....	7
5.3 SAFETY RECOMMENDATIONS FOR THE CORRECT USE OF ABRASIVE PRODUCTS .....	9
5.4 SAFETY RECOMMENDATIONS FOR THE CORRECT USE OF SUPERABRASIVES .....	9
5.5 RESIDUAL RISK.....	10
5.6 CONNECTION TO THE POWER SUPPLY.....	10
<b>6. TECHNICAL DESCRIPTION</b>	
6.1 IDENTIFICATION.....	11
<b>7. UNPACKING AND CHECKING</b>	
7.1 PACKAGING .....	12
7.2 WHAT'S IN THE BOX .....	12
<b>8. ASSEMBLING THE BENCH GRINDER</b>	
8.1 INSTALLATION .....	13
8.2 BENCH MOUNTING YOUR GRINDER – FIG. 1 .....	13
8.3 FITTING THE TOOL RESTS – FIG. 2.....	13
8.4 ATTACHING THE SPARK DEFLECTORS – FIG.3.....	14
8.5 ATTACHING THE EYE SHIELDS – FIG.4 .....	14
8.6 ATTACHING THE COOLING TROUGH ( <i>29621 only</i> ).....	15
<b>9. BASIC GRINDING OPERATIONS</b>	
9.1 OPERATING INSTRUCTIONS .....	16
9.2 GRINDING TIPS .....	16
<b>10. MAINTENANCE AND TROUBLESHOOTING</b>	
10.1 CHANGING THE GRINDING WHEELS .....	17
10.2 TROUBLESHOOTING GUIDE.....	17
<b>11. DISPOSAL</b>	
11.1 DISPOSAL .....	18
<b>12. EXPLANATION OF SYMBOLS</b>	
12.1 EXPLANATION OF SYMBOLS.....	19

## 3. WARRANTY

---

### 3.1 WARRANTY

Draper tools have been carefully tested and inspected before shipment and are guaranteed to be free from defective materials and workmanship.

Should the tool develop a fault, please return the complete tool to your nearest distributor or contact:

**Draper Tools Limited, Chandler's Ford, Eastleigh, Hampshire, SO53 1YF. England.**

**Telephone Sales Desk: +44 (0) 8049 4333 or Product Help Line +44 (0) 23 8049 4344.**

A proof of purchase **must** be provided with the tool.

If upon inspection it is found that the fault occurring is due to defective materials or workmanship, repairs will be carried out free of charge. This warranty period covering parts/labour is 12 months from the date of purchase except where tools are hired out when the warranty period is 90 days from the date of purchase. This warranty does not apply to any consumable parts, any type of battery or normal wear and tear, nor does it cover any damage caused by misuse, careless or unsafe handling, alterations, accidents, or repairs attempted or made by any personnel other than the authorised Draper warranty repair agent.

**Note:** If the tool is found not to be within the terms of warranty, repairs and carriage charges will be quoted and made accordingly.

This warranty applies in lieu of any other warranty expressed or implied and variations of its terms are not authorised.

Your Draper warranty is not effective unless you can produce upon request a dated receipt or invoice to verify your proof of purchase within the warranty period.

Please note that this warranty is an additional benefit and does not affect your statutory rights.

**Draper Tools Limited.**

## 4. INTRODUCTION

---

### 4.1 SCOPE

This bench grinder uses abrasive discs to grind masonry, metal and other materials.

This product is suitable for enthusiasts and tradespersons alike. Any application other than that it was intended for is considered misuse.

### 4.2 SPECIFICATION

Stock No's. ....	29620 .....	29621 .....
Part No's. ....	GHD150 .....	GHD200 .....
Rated voltage .....	230V~50Hz .....	230V~50Hz .....
Rated input .....	370W .....	550W .....
Wheel dimensions		
Diameter .....	150mm .....	200mm .....
Bore .....	12.7mm .....	16mm .....
Width/face .....	19mm .....	25mm .....
Speed (no load) .....	3,000r/min .....	3,000r/min .....
Sound Pressure Level .....	<70dB(A) .....	<70dB(A) .....
Weight (net/gross) .....	11kg/12kg .....	21kg/22kg .....

### 4.3 HANDLING AND STORAGE

- Care must be taken when handling this product.
  - Dropping this power tool could have an effect on its accuracy and could also result in personal injury. This product is not a toy and must be respected.
- Environmental conditions can have a detrimental effect on this product if neglected.
  - Exposure to damp air can gradually corrode components. If the product is unprotected from dust and debris, components will become clogged.
  - If not cleaned and maintained correctly or regularly, the machine will not perform at its best.

## 5. HEALTH AND SAFETY INFORMATION

---

### 5.1 GENERAL SAFETY INSTRUCTIONS FOR POWER TOOL USE

**Warning! Read all safety warnings, instructions, illustrations and specifications provided with this power tool.** Failure to follow all instructions listed below may result in electric shock, fire and/or serious injury.

**Save all warnings and instructions for future reference.**

The term “power tools” in the warnings refers to your mains-operated (corded) power tool or battery-operated (cordless) power tool.

#### 1) Work area safety

- a) **Keep work area clean and well lit.** Cluttered or dark areas invite accidents.
- b) **Do not operate power tools in explosive atmospheres, such as in the presence of flammable liquids, gases or dust.** Power tools create sparks which may ignite the dust or fumes.
- c) **Keep children and bystanders away while operating a power tool.** Distractions can cause you to lose control.

#### 2) Electrical safety

- a) **Power tool plugs must match the outlet. Never modify the plug in any way. Do not use any adapter plugs with earthed (grounded) power tools.** Unmodified plugs and matching outlets will reduce risk of electric shock.
- b) **Avoid body contact with earthed or grounded surfaces, such as pipes, radiators, ranges and refrigerators.** There is an increased risk of electric shock if your body is earthed or grounded.
- c) **Do not expose power tools to rain or wet conditions.** Water entering a power tool will increase the risk of electric shock.
- d) **Do not abuse the cord. Never use the cord for carrying, pulling or unplugging the power tool. Keep cord away from heat, oil, sharp edges or moving parts.** Damaged or entangled cords increase the risk of electric shock.
- e) **When operating a power tool outdoors, use an extension cord suitable for outdoor use.** Use of a cord suitable for outdoor use reduces the risk of electric shock.
- f) **If operating a power tool in a damp location is unavoidable, use a residual current device (RCD) protected supply.** Use of an RCD reduces the risk of electric shock.

#### 3) Personal safety

- a) **Stay alert, watch what you are doing and use common sense when operating a power tool. Do not use a power tool while you are tired or under the influence of drugs, alcohol or medication.** A moment of inattention while operating power tools may result in serious personal injury.
- b) **Use personal protective equipment Always wear eye protection.** Protective equipment such as a dust mask, non-skid safety shoes, hard hat or hearing protection use for appropriate conditions will reduce personal injuries.
- c) **Prevent unintentional starting. Ensure the switch is in the off-position before connecting to power source and/or battery pack, picking up or carrying the tool.** Carrying power tools with your finger on the switch or energising power tools that have the switch on invites accidents.
- d) **Remove any adjusting key or wrench before turning the power tool on.** A wrench or a key left attached to a rotating part of the power tool may result in personal injury.
- e) **Do not overreach. Keep proper footing and balance at all times.** This enables better control of the power tool in unexpected situations.

## 5. HEALTH AND SAFETY INFORMATION

---

- f) **Dress properly. Do not wear loose clothing or jewellery. Keep your hair and clothing away from moving parts.** Loose clothes, jewellery or long hair can be caught in moving parts.
- g) **If devices are provided for the connection of dust extraction and collection facilities, ensure these are connected and properly used.** Use of dust collection can reduce dust-related hazards.
- h) **Do not let familiarity gained from frequent use of tools allow you to become complacent and ignore tool safety principles.** A careless action can cause severe injury within a fraction of a second.

### 4) Power tool use and care

- a) **Do not force the power tool. Use the correct power tool for your application.** The correct power tool will do the job better and safer at the rate for which it was designed.
- b) **Do not use the power tool if the switch does not turn it on and off.** Any power tool that cannot be controlled with the switch is dangerous and must be repaired.
- c) **Disconnect the plug from the power source and/or remove the battery pack, if detachable, from the power tool before making any adjustments, changing accessories, or storing power tools.** Such preventive safety measures reduce the risk of starting the power tool accidentally.
- d) **Store idle power tools out of the reach of children and do not allow persons unfamiliar with the power tool or these instructions to operate the power tool.** Power tools are dangerous in the hands of untrained users.
- e) **Maintain power tools and accessories. Check for misalignment or binding of moving parts, breakage of parts and any other condition that may affect the power tool's operation. If damaged, have the power tool repaired before use.** Many accidents are caused by poorly maintained power tools.
- f) **Keep cutting tools sharp and clean.** Properly maintained cutting tools with sharp cutting edges are less likely to bind and are easier to control.
- g) **Use the power tool, accessories and tool bits etc. in accordance with these instructions, taking into account the working conditions and the work to be performed.** Use of the power tool for operations different from those intended could result in a hazardous situation.
- h) **Keep handles and grasping surfaces dry, clean and free from oil and grease.** Slippery handles and grasping surfaces do not allow for safe handling and control of the tool in unexpected situations.

### 5) Service

- a) **Have your power tool serviced by a qualified repair person using only identical replacements parts.** This will ensure that the safety of the power tool is maintained.

## 5.2 SPECIFIC SAFETY INSTRUCTION FOR BENCH GRINDERS

- Check that speed marked on the wheel is equal to or greater than the rated speed of the grinder.
- Ensure that the wheel dimensions are compatible with the grinder.
- Abrasive wheels shall be stored and handled with care in accordance with manufacturer's instructions.
- Inspect the grinding wheel before use, do not use chipped, cracked or otherwise defective products.
- Ensure that mounted wheels and points are fitted in accordance with the manufacturer's instructions.

## 5. HEALTH AND SAFETY INFORMATION

---

- Ensure that blotters are used when they are provided with the bonded abrasive product and when they are required.
- Ensure that the abrasive product is correctly mounted and tightened before use and run the tool at no-load speed for 30 seconds in a safe position – stop immediately if there is considerable vibration or if other defects are detected. If this condition occurs, check the machine to determine the cause.
- Never use the tool without such a guard.
- Do not use separate reducing bushings or adaptors to adapt large hole abrasive wheels.
- For tools intended to be fitted with threaded hole wheel, ensure that the thread in the wheel is long enough to accept the spindle length.
- Check that the work piece is properly supported.
- Do not use cutting wheel for side grinding.
- Ensure that sparks resulting from use do not create a hazard – e.g. do not hit persons or ignite flammable substances.
- Ensure that ventilation openings are kept clear when working in dusty conditions. If it should become necessary to clear dust, first disconnect the tool from the mains supply (use non metallic objects) and avoid damaging internal parts.
- Always use eye and ear protection.
- Personal protective equipment such as dust mask, gloves, helmet and apron should be worn.
- The wheel continues to rotate after the tool is switched off.
- Stay alert. Watch what you are doing. Use common sense. Do not operate tool when you are tired.

**Wear proper clothing.** Do not wear loose clothing, neckties or jewellery (ring, wristwatches etc.) to catch in moving parts. Non-slip footwear is recommended. Wear protective covering to contain long hair. Roll long sleeves above the elbow.

**Use safety goggles (Head protection).** Wear goggles approved to the relevant standards at all times. Normal spectacles only have impact resistant lenses, they are **NOT** safety glasses. Also, use face or dust mask if application is dusty and ear protectors during all operations.

**Sound levels.** Some types of machines may have high sound levels when working. In such cases ear protection must be worn.

**Vibration levels.** Hand held power tools produce different vibration levels. You should always refer to the specifications and the relevant Health and Safety guidelines.

**Dust extraction.** If your tool is fitted with a dust extraction facility, always ensure that it is connected and being used with a dust extractor. Vacuum cleaners can be used if suitable for the material being extracted.

**Check damaged parts.** Before further use of the tool, a guard or other part that is damaged should be carefully checked to determine that it will operate properly and perform its intended function;

- Check for alignment of moving parts, free running of moving parts, breakage of parts, mounting and any other conditions that may affect its operation. A guard or other part that is damaged should be properly repaired or replaced by an authorised service centre unless otherwise indicated in this instruction manual.
- Have defective switches replaced by an authorised service centre. **Do not use the tool if the switch does not turn it on and off.**

**Have your tool repaired by a qualified person.** This electric tool is in accordance with the relevant safety requirements. Repairs should only be carried out by qualified persons using original spare parts, otherwise this may result in considerable danger to the user.

## 5. HEALTH AND SAFETY INFORMATION

---

### 5.3 SAFETY RECOMMENDATIONS FOR THE CORRECT USE OF ABRASIVE PRODUCTS

**General.** Bonded abrasive products are breakable and shall therefore be handled with utmost care. The use of damaged or improperly mounted or used abrasive products is dangerous and can cause serious injuries.

**Delivery, handling and storage.** Abrasive products must be handled and transported with care. Abrasive products must be stored in such a manner that they are not subjected to mechanical damaged and harmful environmental influences.

**Selection of the abrasive product.** Information on the label or the abrasive product stating restrictions of use, safety indications or any other instructions must be followed. In case of doubt concerning the selection of abrasive products, the user shall request information from the manufacturer or supplier.

**Visual inspection and ring test.** Abrasive products must be subjected to a visual inspection as received before mounting. In addition, a ring test shall be executed for vitrified wheels with  $D > 80$ mm. Damaged abrasive products shall be destroyed.

**Mounting before starting and information for grinding.** The mounting of abrasive products shall be carried out according to the instructions provided by both the wheel and the machine manufacturer. Mounting of abrasive products must be carried out by a qualified trained person. After initial mounting, the wheel must be test run for a reasonable time – the specified maximum operating speed of the wheel shall not be exceeded.

**Further information.** The following instructions must be observed, supplementary to the information contained in the instruction for use of the grinding machine:

- Observance of the user's information from the grinding machine manufacturer.
- Safety devices shall be mounting to the machine and shall be secured.
- No grinding operations without protection by safety devices.
- Use of personal protective equipment according to the type of machine and type of application, e.g. eye and face protection, ear protection, respiratory protective devices, protective footwear, protective gloves and other protective clothing.
- Only grinding operations for which the abrasive product is suitable shall be carried out (taking into account restrictions of use, safety indications or other information).
- Jamming of the hand-held grinding machine shall be prevented. In the case of cutting-off with hand-held grinding machines, the abrasive product shall be placed in the cutting gap in a straight position.
- Before placing the hand-held grinding machine on the workbench or on the floor it shall be turned off and it shall be ensured that the abrasive product has stopped.

### 5.4 SAFETY RECOMMENDATIONS FOR THE CORRECT USE OF SUPERABRASIVES

**General.** Superabrasives are breakable and shall therefore be handled with utmost care! The use of damaged or improperly mounted or used superabrasives is dangerous and can cause serious injuries.

**Delivery, handling and storage.** Superabrasives shall be handled and transported with care. Superabrasives shall be stored in such a manner that they are not subjected to mechanical damages and harmful environmental influences.

**Selection of superabrasives.** Information on the label or the superabrasive as well as restrictions of use, safety indications or any other instruction shall be followed. In case of doubt concerning the selection of superabrasives, the user shall request information from the manufacturer or supplier.

**Visual inspection and ring test.** Superabrasives shall be subjected to a visual inspection as received before mounting. In a addition, a ring test shall be executed for superabrasives with vitrified core and abrasive section and  $D > 80$ mm. Damaged superabrasives shall not be used.

**Mounting, before starting and information for grinding.** The mounting of superabrasive shall be carried out according to the instructions provided by both, the superabrasive and the machine manufacturer. Special attention shall be drawn to the fact that mounting of superabrasives is to be

## 5. HEALTH AND SAFETY INFORMATION

---

carried out by a qualified trained person. Each time after mounting, the superabrasive shall be test run for a reasonable time – the specified maximum operating speed of the superabrasive shall not be exceeded.

**Further information.** The following instructions shall be observed, supplementary to the information of the grinding machine:

- Observance of the user's information of grinding machine manufacturer.
- Before starting, safety devices shall be mounted to the machine.
- No grinding operations without protection by safety devices.
- Use of personal protective equipment according to the type of machine and type of application, e.g. eye and face protection, ear protection, respiratory protection devices, protective footwear, protective gloves and other protective clothing.
- Only grinding operations for which the superabrasive is suitable shall be carried out (taking into account restrictions of use, safety indications or other information).
- In the case of cutting-off with hand-held grinding machines, the superabrasive shall be placed in the cutting gap in a straight position. Jamming of the hand-held grinding machine shall be prevented.
- Before placing the hand-held grinding machine on the workbench or on the floor it shall be turned off and it shall be ensured that the abrasive product has stopped.

### 5.5 RESIDUAL RISK

**Important:** Although the safety instructions and operating manuals for our tools contain extensive instructions of safe working with power tools, every power tool involves a certain residual risk which can not be completely excluded by safety mechanisms. Power tools must therefore always be operated with caution!

### 5.6 CONNECTION TO THE POWER SUPPLY

**Caution:** Risk of electric shock. Do not open.

This appliance is supplied with an approved plug and cable for your safety. The value of the fuse fitted is marked on the pin face of the plug. Should the fuse need replacing, ensure the substitute is of the correct rating, approved to BS1362 and ASTA or BS Kite marked.

ASTA 

BSI 

The fuse cover is removable with a small plain slot screwdriver. Ensure the fuse cover is replaced before attempting to connect the plug to an electrical outlet. If the cover is missing, a replacement must be obtained or the plug replaced with a suitable type.

If a replacement plug is to be fitted this must be carried out by a qualified electrician.

The damaged or incomplete plug, when cut from the cable shall be disabled to prevent connection to a live electrical outlet.

This appliance is Class I † and is designed for connection to a power supply matching that detailed on the rating label and compatible with the plug fitted.

If an extension lead is required, use an approved and compatible lead rated for this appliance. Follow all the instructions supplied with the extension lead.

†Earthed:  This product requires an earth connection to protect against electric shock from accessible conductive parts in the event of a failure of the basic insulation.

#### **Important**

**If using an extension lead, follow the instructions that came with your lead regarding maximum load while cable is wound. If in doubt, ensure that the entire cable is unwound. Using a coiled extension lead will generate heat which could melt the lead and cause a fire.**

## 6. TECHNICAL DESCRIPTION

### 6.1 IDENTIFICATION

Stock No. 29621

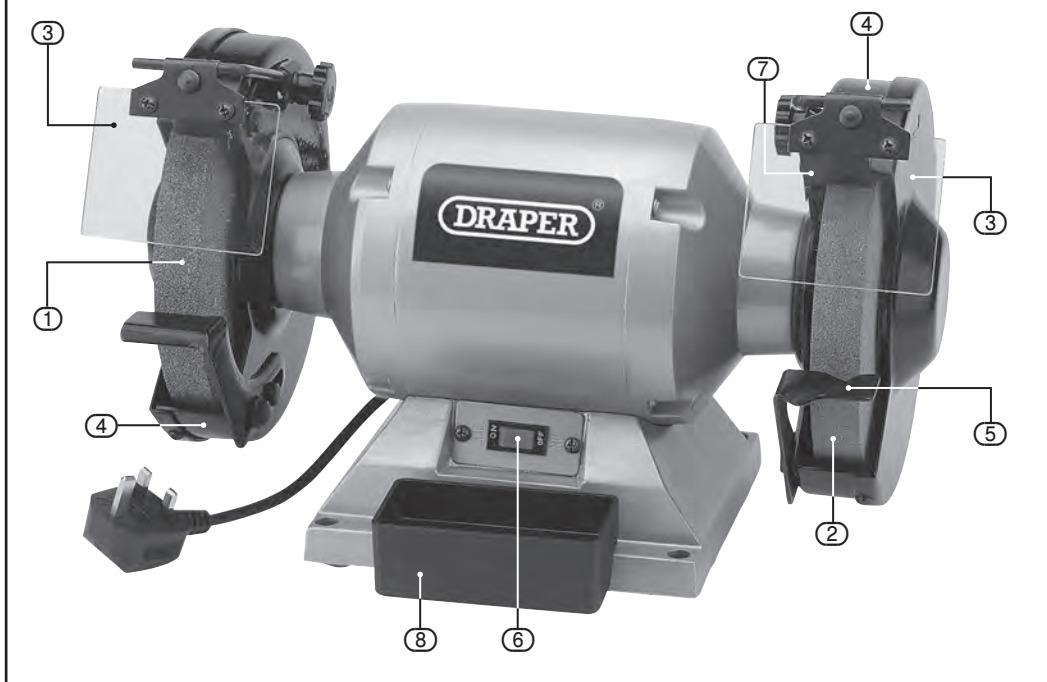

① Coarse grinding wheel.

② Fine grinding wheel.

③ Eyeshields.

④ Wheel guards.

⑤ Adjustable tool rests.

⑥ ON/OFF switch.

⑦ Spark deflector.

⑧ Cooling trough (29621 only).

# 7. UNPACKING AND CHECKING

## 7.1 PACKAGING

Carefully remove the product from the packaging and examine it for any sign of damage that may have happened during shipping. Lay the contents out and check them against the parts shown below. If any part is damaged or missing, please contact the Draper Help Line (the telephone number appears on the Title page) and do not attempt to use the product.

The packaging material should be retained at least during the warranty period, in case the machine needs to be returned for repair.

### Warning!

- Some of the packaging materials used may be harmful to children. Do not leave any of these materials in the reach of children.
- If any of the packaging is to be thrown away, make sure they are disposed of correctly, according to local regulations.

## 7.2 WHAT'S IN THE BOX

As well as the main product, there are several parts not fitted or attached to it.



- (A) Tool rests (5) and fittings.
- (B) Spark deflector and fittings.
- (C) Spark deflector and fittings.
- (D) Eye shields and fittings.

**Note:** For details of our full range of accessories and consumables, please visit [drapertools.com](http://drapertools.com)

## 8. ASSEMBLING THE BENCH GRINDER

### 8.1 INSTALLATION

Choose a location that is level, flat and with a lot of natural light.

The bench grinder should be operated on a work bench that is high enough to prevent any injury caused by working in an uncomfortable position; but not too high that the work piece cannot be safely viewed from above.

#### Warning!

Bending over or having your neck bent for too long (from looking down) can lead to fatigue injuries.

The environment will have a negative result on its operation if you are not careful. If the air is damp, components will rust. If the machine is unprotected from dust and debris; components will become clogged: And if not cleaned and maintained correctly or regularly the machine will not perform at its best.

The work bench should offer enough space around the bench grinder for all possible applications and to house any accessories.

Although the bench grinder has been assembled in the factory, some final assembly and adjustments will be required before it can be used. The fine setup will come from experimenting with your new bench grinder and making small adjustments.

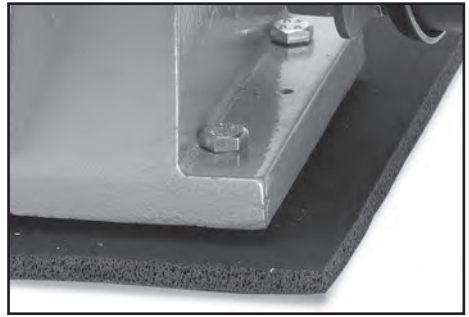

FIG.1

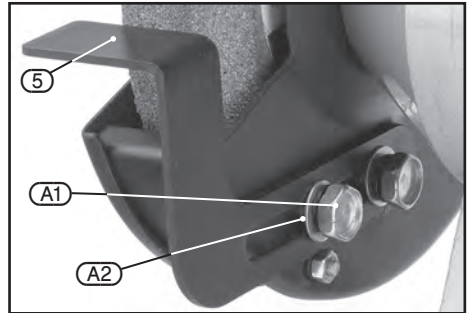

FIG.2

### 8.2 BENCH MOUNTING YOUR GRINDER – FIG. 1

Securely bolt the bench grinder to a work bench or other secure surface through the various points in the base (fixings are not supplied).

Ensure there is enough clear space around the grinder to accommodate large items which may be ground, i.e., garden tools, etc. To reduce any vibration, mount the grinder on a vibration absorption mat.

### 8.3 FITTING THE TOOL RESTS – FIG. 2

- Attach the left and right hand tool rests using the fittings from Group (A) shown in **7.2 WHAT'S IN THE BOX** section on page 12.
- Fit both tool rests (5) to the inner edge of the wheel guards using the bolts (A1) and washers (A2) provided.
- Adjust them so there is approx. 1.5mm between the grinding wheel face and the tool rest.

#### Caution!

Ensure both washers are fitted between the bolt and the tool rest. Neglecting to install the washers correctly may result in the tip of the bolt contacting the side of the abrasive wheel.

## 8. ASSEMBLING THE BENCH GRINDER

### 8.4 ATTACHING THE SPARK DEFLECTORS – FIG.3

- Attach the left and right hand spark deflectors using the fittings from group's (B) and (C) shown in 7.2 WHAT'S IN THE BOX section on page 12.
- Attach the spark deflectors using the two bolts (B.1) and medium size washers (B.2) as shown in Fig.3.
- When fitted, adjust the spark deflectors so that there is approximately a 1.5mm (1/16") gap between the surface of the grinding wheels and spark deflectors.

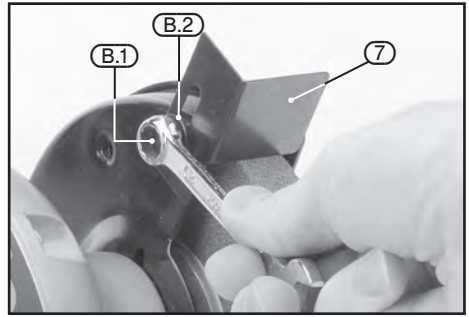

FIG.3

### 8.5 ATTACHING THE EYE SHIELDS – FIG.4

- Attach the eye shields using the fittings from group (D) shown in 7.2 WHAT'S IN THE BOX section on page 12.
- Place the eye shield frame (D.1) over the eye shield (D.2) fasten the two parts together using the long screws, washers and nuts, as shown in Fig.4. **Note:** Do not overtighten as the eye shield may crack.
- Assemble the other eyeshield in the same way.
- Insert the shortest end of the mounting rod (D.3) into the hole in the shield frame (D.1) (Fig.5).
- Tighten the nut and round headed bolt which are located in the centre of each of the eye shield mounting frames.
- To fit the eye shields to the bench grinder attach clamp (D.4) to the wheel guard using lock knob (D.5) large star washer and large washer as shown in Fig.6. Insert mounting rod into the clamp, position as required and tighten lock knob. The eye shield is fully adjustable. It can be adjusted by either loosening the lock knob and moving the rod or by moving the eye shields.

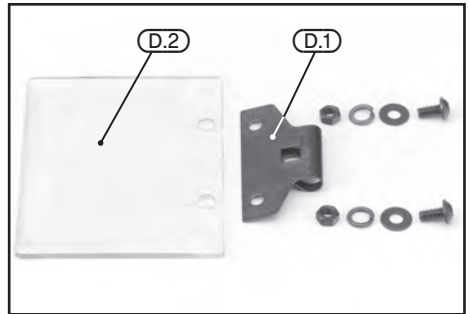

FIG.4

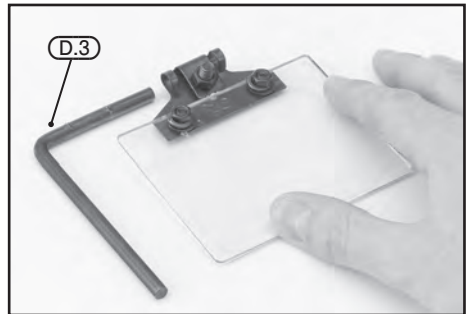

FIG.5

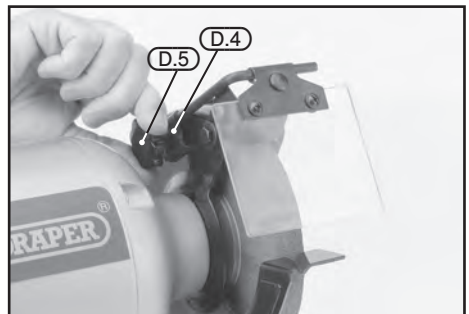

FIG.6

## 8. ASSEMBLING THE BENCH GRINDER

---

### 8.6 ATTACHING THE COOLING TROUGH (29621 only)

Attach the cooling trough to the bench grinder by inserting the lug on the bottom of the tray into the hole in the base at the front of the bench grinder. (Fig.7).

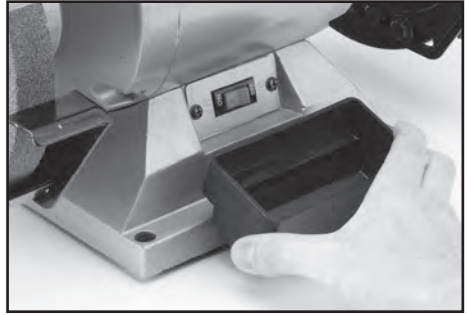

FIG.7

# 9. BASIC GRINDING OPERATIONS

---

## 9.1 OPERATING INSTRUCTIONS

A bench grinder is designed for hand grinding operations only, such as sharpening drill bits, chisels and screwdrivers or removing excess metal from workpieces.

A coarse grit grinding wheel could be used for grinding rough metals, to remove large amounts of metal, or where a smooth finish is not important.

A fine grit grinding wheel could be used for sharpening tools or grinding close to size. A fine grit wheel removes a metal more slowly and therefore gives the workpiece a smooth finish and does not generate enough heat to anneal the cutting edges.

- Check that there is a 1.5mm (1/16") clearance between the tool rests and the surface of the grinding wheels. Adjust as necessary. Now check the gap between the spark deflectors and the surface of the grinding wheels. These should also be 1.5mm (1/16"). Adjust as necessary. The tool rests should be adjusted so that they are just below the centre line of the grinding wheels. This should help prevent accidental jamming of the work between the tool rest and the wheel.
- Check that the eye shields have been secured in the correct position and that the grinding wheel lock nuts are tight.

**Note:** Before fitting a new grinding wheel to the bench grinder always carefully check the wheel for damage such as chips, flaws or cracks. Then if the new wheel appears to be satisfactory fit the wheel to the grinder. Stand to one side of the grinder and switch "ON". Let the grinder operate at full speed for approximately one minute so that any undetected cracks or flaws in the wheel will become apparent.

- Stand to one side of the bench grinder, switch on and let it build up to full speed.
- When grinding, always keep the workpiece moving across the face of the wheel. Grinding against the same part of the wheel will cause uneven wear of the wheel face.
- When necessary redress the grinding wheels using a wheel dressing tool. After redressing adjust the tool rests and spark deflectors as necessary to maintain a 1.5mm (1/16") clearance from the wheel.

## 9.2 GRINDING TIPS

Ensure that the item to be ground is comfortably and securely held. Adjust tool rest to correct angle. Present the workpiece smoothly on to the grinding wheel face with a light and even pressure. Grind against the edge of the workpiece to avoid burrs. Never grind on the sides of the wheels.

Best results are achieved if the grinder is allowed to rotate at its maximum speed. Excess pressure from the workpiece can damage the wheel and overload the motor.

Check grinding wheels regularly for wear or damage. Replace wheels that are worn more than 25%. Damaged wheels should be discarded immediately as they are dangerous and can cause the grinder to vibrate.

After grinding fine edge tools, they should be honed by hand on a fine slip stone.

# 10. MAINTENANCE AND TROUBLESHOOTING

## 10.1 CHANGING THE GRINDING WHEELS

For your own safety, always turn the main switch on the machine “OFF” and remove the plug from the power supply before carrying out any servicing or maintenance.

- Remove the screws which secure the grinding wheel side covers then take off covers.
- Either, hold the opposite wheel firmly and remove the nut and flange, or place a wedge between the grinding wheel and the wheel guard, then remove the nut and flange.

**Note:** the left hand grinding wheel nut has a left thread.

- When fitting a new grinding wheel always check that the stated max. grinding wheel RPM exceeds the RPM of the bench grinder. Also check the grinding wheel for damage such as flaws or cracks, then if the wheel appears satisfactory fit the new wheel to the grinder.
- Remove the old wheel and replace it with the new one.
- Place the flange on the spindle and tighten the spindle nut just enough to hold the wheel firmly. Do not over tighten the nut as the wheel may become damaged. Repeat the above to replace the opposite wheel.
- Re-assemble the side covers.
- Stand to one side of the grinder and switch “ON”. Let the grinder operate at full speed for approximately one minute so that any undetected cracks or flaws in the wheel will become apparent.

## 10.2 TROUBLESHOOTING GUIDE

### Warning!

For your own safety, always turn the main switch on the machine “Off” and remove the plug from the power supply before carrying out any servicing or maintenance.

Problem	Possible Cause	Remedy
Machine will not start.	Fuse. Other.	5 amp time delay fuse or circuit breaker. Authorised service agent.
Machine vibrates.	Wheel out of balance. Wheel loose. Damaged wheel (consumable item).	Dress wheels. Stop machine immediately. Tighten wheel. Replace wheel (consumable item).

# 11. DISPOSAL

---

## 11.1 DISPOSAL

- At the end of the machine's working life, or when it can no longer be repaired, ensure that it is disposed of according to national regulations.
- Contact your local authority for details of collection schemes in your area.

In all circumstances:

- Do not dispose of power tools with domestic waste.
- Do not incinerate.
- Do not dispose of WEEE\* as unsorted municipal waste.



\* *Waste Electrical & Electronic Equipment.*

# 12. EXPLANATION OF SYMBOLS

## 12.1 EXPLANATION OF SYMBOLS



Read the instruction manual.



Wear face mask and safety glasses.



Wear ear defenders.



Do not abandon into the environment.



Keep out of the reach of children.



**Warning!**



Rated wattage input.



No-load speed (revolutions per minute).



Wheel size.



Bore size.



Net product weight  
(*example shown*).



Earthed.



WEEE –  
Waste Electrical & Electronic Equipment.  
Do not dispose of Waste Electrical & Electronic Equipment in with domestic rubbish.



Continuous A-Weighted Sound Pressure Level (*example shown*).



UK Conformity Assessed.



European conformity.

# CONTACTS

Draper Tools Limited

UK: Hursley Road, Chandler's Ford, Eastleigh,  
Hampshire. SO53 1YF. U.K.

EU: Oude Graaf 8  
6002 NL Weert (NL)

Help Line: (023) 8049 4344

Sales Desk: (023) 8049 4333

Internet: [drapertools.com](http://drapertools.com)

E-mail: [sales@drapertools.com](mailto:sales@drapertools.com)

General Enquiries: (023) 8026 6355

Service/Warranty Repair Agent:

For aftersales servicing or warranty repairs, please contact the  
Draper Tools Help Line for details of an agent in your local area.

## YOUR DRAPER STOCKIST

RDCH0721

©Published by Draper Tools Limited.

No part of this publication may be reproduced, stored in a retrieval system or transmitted in any form or by any means, electronic, mechanical photocopying, recording or otherwise without prior permission in writing from Draper Tools Ltd.