

Copyright Information

Copyright © 2024 by LAUNCH TECH CO., LTD. All rights reserved. No part of this publication may be reproduced, stored in a retrieval system, or transmitted in any form or by any means, electronic, mechanical, photocopying, recording or otherwise, without the prior written permission of LAUNCH. The information contained herein is designed only for the use of this unit. LAUNCH is not responsible for any use of this information as applied to other units.

Important Safety Information

Warning: To avoid personal injury, property damage, or accidental damage to the product, read all of the information in this section before using the product.

Work Area Safety

- Keep work area clean and well lit. Cluttered benches and dark areas may cause accidents.
- Do not connect or disconnect the tool while the ignition is on or the engine is running.
- DO NOT attempt to operate the tool while driving the vehicle. Have a second person to operate the tool.
- Before testing a vehicle, put the transmission in PARK (for automatic transmission) or NEUTRAL (for manual transmission). Engage the parking brake and chock the tires.
- NEVER smoke or allow a spark or flame in vicinity of battery or engine.
- The vehicle shall be tested in a well-ventilated work area, as engines produce various poisonous compounds (hydrocarbon, carbon monoxide, nitrogen oxides, etc.)
- Do not operate the tool in explosive atmospheres, such as in the presence of flammable liquids, gases, or heavy dust.
- Never leave the vehicle unattended while testing.
- Keep a fire extinguisher suitable for gasoline/chemical/electrical fires nearby.
- Use extreme caution when working around the ignition coil, distributor cap, ignition wires and spark plugs. These components create hazardous voltages when the engine is running.
- Keep bystanders, children and visitors away while operating the tool.
- This product is not a toy. Do not allow children to play with or near this tool.
- Use as intended only. Do not modify.
- Inspect before every use; do not use if parts are loose or damaged.
- Do not place the tool on any unstable surface.
- Handle the tool with care. If the tool is dropped, check for breakage and any other conditions that may affect its operation.
- Keep the tool dry, clean, free from oil, water or grease. Use a mild detergent on a clean cloth to clean the outside of the tool when necessary.
- Store the tool and accessories in a locked area out of the reach of children.
- To avoid damaging the tool or generating false data, please make sure the vehicle battery is fully charged and the connection to the vehicle DLC (Data Link Connector) is clear and secure.
- If the VCI (Vehicle Communication Interface) is not in use for a long period of time, it is suggested to unplug the VCI from vehicle's DLC to conserve battery power.

Electrical Safety

LAUNCH

- Do not use the tool while standing in water.
- Avoid body contact with grounded surfaces such as pipes, radiators, ranges and refrigerators.
- **Do not expose the tool or power adaptor to rain or wet conditions.** Water entering the tool or power adaptor increases the risk of electric shock.

Personal Safety

- Wear an ANSI-approved eye shield when testing or repairing vehicles.
- Do not wear loose clothing or jewelry. Keep hair, clothing, hands, tools, and test equipment away from moving or hot engine parts. Loose clothes, jewelry, or long hair can be caught in moving parts.
- Do not use the tool while tired or under the influence of drugs, alcohol, or medications. A moment of interruption can result in serious personal injury.
- People with pacemakers should consult their physician(s) before use. Electromagnetic fields in close proximity to heart pacemaker could cause pacemaker interference or pacemaker failure.
- The warnings, precautions, and instructions discussed in this instruction manual cannot cover all possible conditions and situations that may occur. It must be understood by the operator that common sense and caution are factors which cannot be built into this product, but must be supplied by the operator.
- There are no user serviceable parts. Have the tool serviced by a qualified repair person using only identical replacement parts. This will ensure that the safety of the equipment is maintained.
- Please use the included battery and charger. Risk of explosion if the battery is replaced with an incorrect type.
- Automotive batteries contain sulfuric acid that is harmful to skin. In operation, direct contact with the automotive batteries should be avoided. Keep the ignition sources away from the battery at all times.

Precautions on Operating Vehicle's ECU

- Do not disconnect battery or any wiring cables in the vehicle when the ignition switch is on, as this could avoid damage to the sensors or the ECU.
- Do not place any magnetic objects near the ECU. Disconnect the power supply to the ECU before performing any welding operations on the vehicle.
- Use extreme caution when performing any operations near the ECU or sensors. Ground yourself when you disassemble PROM, otherwise ECU and sensors can be damaged by static electricity.
- When reconnecting the ECU harness connector, be sure it is attached firmly, otherwise electronic elements, such as ICs inside the ECU, can be damaged.

Compliance Information

FCC ID: XUJX431PROV5

IC: 29886-PO1005A

Any changes or modifications not expressly approved by the party responsible for compliance could void the user's authority to operate the equipment.

This device complies with Part 15 of the FCC Rules. Operation is subject to the following two conditions:

- (1) This device may not cause harmful interference, and
- (2) This device must accept any interference received, including interference that may cause undesired operation.

Note: This equipment has been tested and found to comply with the limits for a Class B digital device, pursuant to part 15 of the FCC Rules. These limits are designed to provide reasonable protection against harmful interference in a residential installation. This equipment generates, uses and can radiate radio frequency energy and, if not installed and used in accordance with the instructions, may cause harmful interference to radio communications. However, there is no guarantee that interference will not occur in a particular installation. If this equipment does cause harmful interference to radio or television reception, which can be determined by turning the equipment off and on, the user is encouraged to try to correct the interference by one or more of the following measures:

- Reorient or relocate the receiving antenna.
- Increase the separation between the equipment and receiver.
- Connect the equipment into an outlet on a circuit different from that to which the receiver is connected.
- Consult the dealer or an experienced radio/TV technician for help.

This device contains licence-exempt transmitter(s) that comply with Innovation, Science and Economic Development Canada's licence-exempt RSS(s). Operation is subject to the following two conditions:

- (1) This device may not cause interference.
- (2) This device must accept any interference, including interference that may cause undesired operation of the device.

Le présent appareil est conforme aux CNR d'Industrie Canada applicables aux appareils radio exempts de licence. L'exploitation est autorisée aux deux conditions suivantes:

- (1) l'appareil ne doit pas produire de brouillage, et
- (2) l'utilisateur de l'appareil doit accepter tout brouillage radioélectrique subi, même si le brouillage est susceptible d'en compromettre le fonctionnement.

The device and the distance from the human body during normal use is 0mm, RF exposure limit is 1.6 W/Kg. The device has been evaluated to meet general RF exposure requirement. The highest reported SAR is below the maximum value.

We declare that this device is in compliance with the essential requirements and other relevant provisions of Radio Equipment Directive 2014/53/EU.

TABLE OF CONTENTS

1 Introduction	1
1.1 Product Profile	1
1.2 Package List	1
1.3 Components & Controls.....	2
1.3.1 Display Tablet	2
1.3.2 SmartLink C V2.0 Device.....	4
1.4 Technical Parameters.....	5
2 Initial Use	6
2.1 Charging & Turning On.....	6
2.2 Screen Layout.....	6
2.3 Adjust Brightness	6
2.4 Change System Language	6
2.5 Set Standby Time.....	6
2.6 WLAN Setup	7
3 Register & Update	8
3.1 Register & Update.....	8
3.2 Job Menu.....	9
4 Connections	11
4.1 Preparation	11
4.2 Vehicle Connection	11
4.3 Communication Setup	12
5 Diagnosis	13
5.1 Intelligent Diagnose.....	13
5.2 Local Diagnose	15
5.3 Remote Diagnose	21
5.3.1 SmartLink Super Remote Diagnostics	21
5.3.2 X431 Remote Diagnostics	23
5.4 EV (Electric Vehicle) Diagnose	28
5.4.1 Vehicle Diagnosis	28
5.4.2 Battery Pack Detection	29
5.5 Feedback.....	30
5.6 Diagnostic History	30
6 Service Function (Reset)	32
7 Software Update	33
7.1 Update Diagnostic Software & APP.....	33
7.2 Update Frequently Used software	33
7.3 Renew Subscription	34
8 Toolbox	35
8.1 TPMS	35
8.2 ADAS (Calibration).....	35

8.3 Oscilloscope	35
8.4 Sensor Simulator.....	35
8.5 Videoscope	35
8.6 BST360 (Battery Tester).....	35
8.7 Multimeter	36
8.8 Current Clamp.....	36
8.9 Insulation Tester.....	36
8.10 Immobilizer Programmer.....	36
8.11 Key Programmer	36
9 Diagnostic Widget	37
9.1 Vehicle Coverage.....	37
9.2 CAN Bus Pin Detection.....	37
9.3 CANScope	37
9.4 Diagnostic Software Clear	37
9.5 Fix Connector Firmware/System	37
9.6 Data Stream Sample	37
9.7 DLC Voltage Check.....	37
9.8 Reset MSVIN.....	37
9.9 Diagnostic History	37
10 User Info.....	38
10.1 My Report	38
10.2 VCI	38
10.3 Activate VCI.....	38
10.4 Profile	38
10.5 My Order.....	38
10.6 Change Password.....	38
10.7 Login/Log out	38
11 Settings	39
11.1 Units	39
11.2 Shop information	39
11.3 Printer set	39
11.4 Clear cache.....	40
11.5 Diagnostic software auto update	40
11.6 Device account management.....	40
12 J2534 Reprogramming.....	42
13 FAQ.....	43
13.1 About diagnostic tablet	43
13.2 About SmartLink Diag.....	44
Warranty.....	45

1 Introduction

1.1 Product Profile

It inherits from LAUNCH's advanced diagnosing technology and is characterized by covering a wide range of vehicles, featuring powerful functions, and providing precise test result.

It has the following features: Intelligent Diagnose, Local Diagnose, EV (Electric Vehicle) Diagnose & Service, SmartLink Super Remote Diagnose, X431 Remote Diagnose, Service Function, Toolbox, Software Update, Feedback, Online Mall and Diagnostic History etc.

1.2 Package List

Common accessories are same, but for different destinations, the accessories (such as diagnostic software, testing connectors) may vary. Please consult from the seller or check the package list supplied with this tool together.

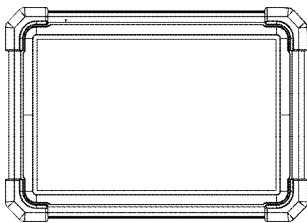

Display tablet x 1

Indicates the test result.

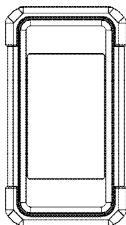

SmartLink C V2.0 device x 1

Collects vehicle data and sends it to the tablet for analysis.



Diagnostic cable x 1

Connects the SmartLink C device to the OBD II vehicle's DLC.



Data cable (Type A-Type C) x 1

Connects the tablet to a PC for data exchange/charging.



Data cable (Type A-Type B) x 1

Connects the SmartLink C device to PC for J2534 reprogramming/Connects the SmartLink C device to diagnostic tablet to perform vehicle diagnosis.



Crossover cable x 1

Connects the SmartLink C device to the modem.

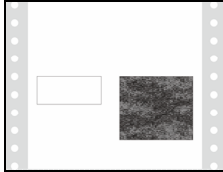

Password envelope x 1

A piece of paper bearing the product Serial Number and Activation Code for product registration.

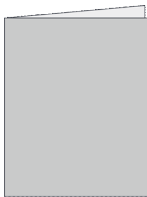

Quick start guide x 1

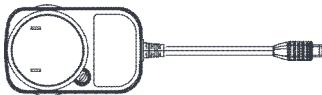

Power adaptor x 1 + switching adaptor x 2

Charges the tablet via the AC outlet.

Non-16pin adaptor kit for passenger cars (optional)

For different vehicle diagnostic socket, it may be necessary to use one of the non-16pin connectors included within the kit.

For detailed non-16pin connectors, please check the package box.

1.3 Components & Controls

There are two main components to the diagnostic system:

- Display Tablet – the central processor and monitor for the system (See **Chapter 1.3.1**).
- SmartLink C V2.0 Device – the device for accessing vehicle data (See **Chapter 1.3.2**).

1.3.1 Display Tablet

The tablet acts as the central processing system, which is used to receive and analyze the live vehicle data from the SmartLink C device and then output the test result.

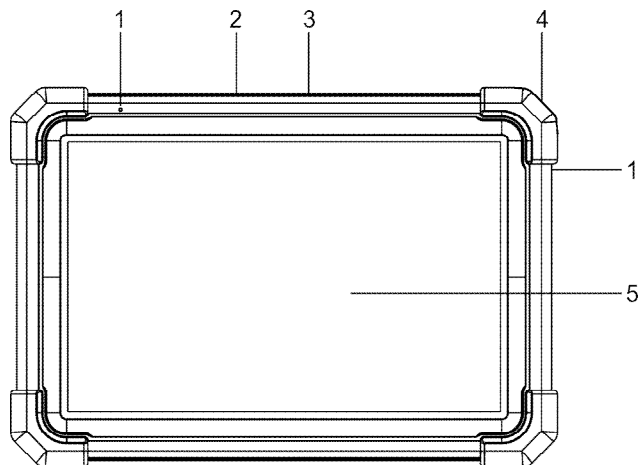

1. Microphone

2. Type-A USB Port

- Connect to the SmartLink C device to perform vehicle diagnosis via the USB cable.
- Connect to compatible add-on modules (such as Videoscope) or USB storage devices.

3. Type-C USB Port

- Connect to AC outlet for charging.
- Connect to PC for data exchange.

4. POWER Key

Turn the tablet on/off.

Note: Press and hold it for 8 seconds to perform forced shutdown.

5. LCD Screen

Indicate the test result.

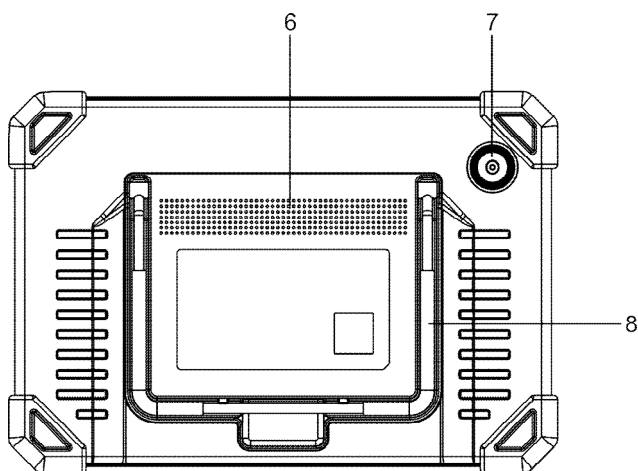

6. Speakers

7. Rear Camera

8. Adjustable stand

Flip it out to any angle and work comfortable at your desk, or hang it on steering wheel.

1.3.2 SmartLink C V2.0 Device

The SmartLink C V2.0 device features powerful functions and it can be applied in the following situations:

- 1). When as a VCI (Vehicle Communication Interface), it needs to work in conjunction with the **Diagnose** module of the tablet, which is used to obtain vehicle data, and then send it to the tablet for analysis wirelessly or via data cable.
- 2). When as a SmartLink C (Customer) dongle, it does not communicate with the tablet, but it needs to work together with the **SmartLink** module of the tablet. The tablet is mainly used to issue remote diagnostic requests, and the SmartLink C dongle is networked to receive and execute commands from the remote SmartLink B (Business).

Note: For detailed operations, please refer to Chapter 5.3.1.

- 3). When as a local J2534 PassThru device, it can be used in conjunction with the PC installed with OEM diagnostic software.

Note: For detailed operations, please refer to Chapter 12.

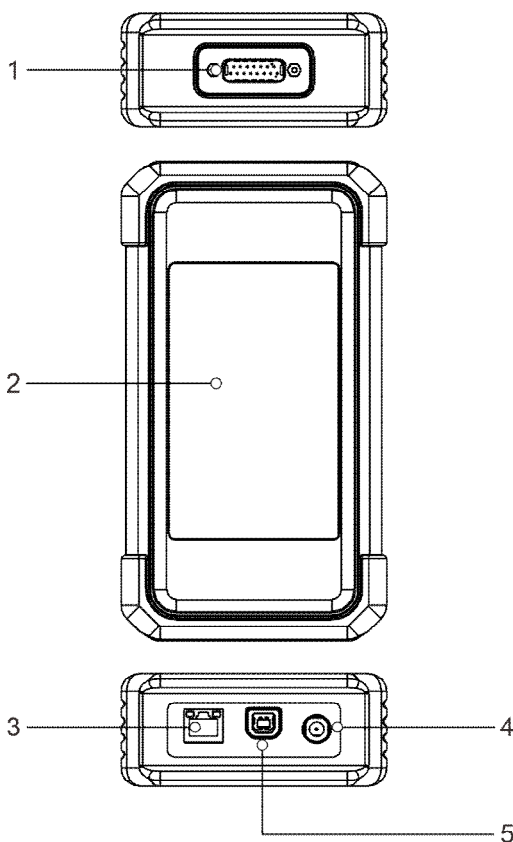

1. DB-15 diagnostic connector

Connect it to the vehicle's DLC (Data Link Connector) port via the diagnostic cable.

2. Touch screen

3. LAN/WAN port

Connect it to the modem via the crossover cable. It only applies to the SmartLink Super Remote Diagnostics.

4. DC-IN power jack

It can obtain power via connecting the diagnostic cable to the vehicle's DLC port or connecting to an external DC power supply.

Warning: It is prohibited to connect this power jack to an external DC power supply when the SmartLink C V2.0 device is properly connected to the vehicle's DLC port.

No responsibility can be assumed for any damage or loss caused as a result of not strictly following the warning.

5. Data I/O port

- Connect it to the tablet to perform vehicle diagnosis.
- Connect it to the PC to perform J2534 reprogramming when as a J2534 PassThru device.

1.4 Technical Parameters

1. Display tablet

Operating system: Android

Memory: 4GB

Storage: 64GB

Screen: 10.1 inch capacitive touch screen with a resolution of 1280 x 800 pixels

Camera: Rear-facing 8.0MP camera

Connectivity:

- Wi-Fi (802.11a/b/g/n/ac)
- Bluetooth

Working temperature: 0°C ~ 50°C

Storage temperature: -20°C ~ 70°C

2. SmartLink C V2.0 device

Size: 200mm x 110mm x 47mm

Working voltage: DC 9~36V

Power consumption: ≤ 6W



Communication: wireless and wired

Working temperature: 0°C~ 50°C

2 Initial Use

2.1 Charging & Turning On

1. Plug one end of the included charging port of the tablet, and the other end to the power adaptor.
2. Connect the other end to the AC outlet.

If  appears on the screen, it indicates it is being charged. If the logo changes into , it indicates that the battery is fully charged. Unplug the power adaptor from the tablet.





Note: If the battery remains unused for a long period of time or the battery is completely discharged, it is normal that the tool will not power on while being charged. Please charge it for a period of 5 minutes and then turn it on.

Warning: Please use the included power adaptor to charge your tool. No responsibility can be assumed for any damage or loss caused as a result of using power adaptors other than the one supplied.

Press [POWER] for 3 seconds, an option menu will pop up on the screen. Tap **Power off** to turn the tool off.

2.2 Screen Layout

The following on-screen buttons are available on the bottom of the screen.

-  **BACK:** Tap it to return to the previous screen.
-  **HOME:** Tap it to navigate to the Android's home screen.
-  **Recent Apps:** Tap it to view the recently launched applications.
-  **Screenshot:** Tap it to capture the current screen.

2.3 Adjust Brightness

Note: Reducing the brightness of the screen is helpful to conserve the battery power.

1. On the home screen, tap **Settings -> Display -> Brightness level**.
2. Drag the slider to adjust it.

2.4 Change System Language

The tool supports multiple system languages. To change the language of the tool, please do the following:

1. On the home screen, tap **Settings -> System -> Language & input -> Languages**.
2. Tap **Add a language**, and then choose the desired language from the list.
3. Tap and hold the desired language and drag it to the top of the screen and then release it, the system will change into the target language.

2.5 Set Standby Time

If no activities are made within the defined standby period, the screen will be locked automatically and the system enters sleep mode to save power.

1. On the home screen, tap **Settings -> Display -> Advanced -> Sleep**.
2. Choose the desired sleep time.

2.6 WLAN Setup

The tablet has built-in Wi-Fi that can be used to get online. Once you're online, you can register the tool, surf the Internet, get apps, send email, launch the remote diagnosis, and check for software updates etc.

Connect to a Wi-Fi network

1. On the home screen, tap **Settings -> Network & Internet -> WLAN**.
2. Slide the Wi-Fi switch to ON, the tablet starts searching for available wireless networks.
3. Select a wireless network,
 - If the chosen network is open, the tablet will connect automatically.
 - If the selected network is encrypted, a network password will need to be entered.
4. When **Connected** appears, it indicates the Wi-Fi connection is complete.

Note: When Wi-Fi is not required, this should be disabled to conserve battery power.

Disconnect from a Wi-Fi network

1. On the home screen, tap **Settings -> Network & Internet -> WLAN**.
2. Tap the network with a **Connected** status, then tap **Disconnect**.

3 Register & Update

3.1 Register & Update

For initial use, the registration is the necessary first procedure to activate the tool.

Tap the application icon on the home screen to launch it, and then tap **Login** on the upper right corner of the screen to enter the following screen.

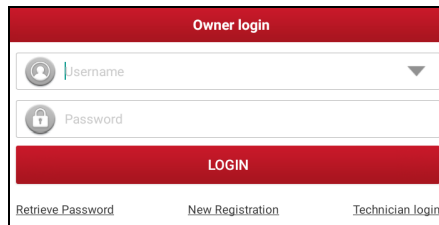

(If you are a new user, follow A to proceed.)

(If you have registered to be a member, go to B to login the system directly.)

(If you have bound a sub-account to this tool, go to C to login the system.)

(In case you forgot password, refer to D to reset a new password.)

A. If you are a new user, tap **New Registration** to enter the sign-up page.

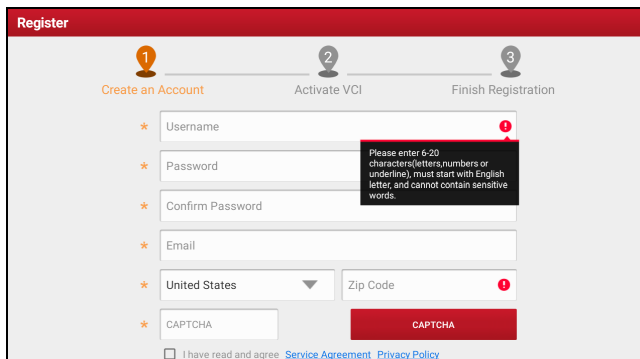

In the above figure, fill in the information in each field (Items with * must be filled). After inputting, tap **Register**, a screen similar to the following will appear:

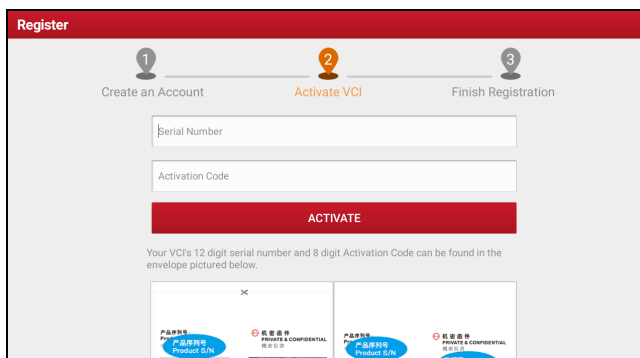

Input the 12-digit Product Serial Number and 8-digit Activation Code (can be obtained from the password envelope), and then tap **Activate**.

LAUNCH

	 Note: This function needs to work with New Energy Vehicle Diagnosis Add-on Kit (optional), which can be purchased from the authorized dealer.
Special Function	It offers coding, reset, relearn and more service functions, to help vehicles get back to functional status after repair or replacement.
Toolbox	Additional add-on tools include TPMS, ADAS, Oscilloscope, Sensor simulator, BST360 Battery Tester, Immobilizer programmer, Videoscope, Current clamp, Multimeter, Insulation Tester, Key programmer and more.
Software Update	To update vehicle diagnostic software and APK.
X-431 Diagnostic Kit	Includes vehicle coverage, CANBUS pin detection, CANScope, and Fix connector firmware/system etc.
Feedback	To feed back the recent 20 diagnostic logs to us for issue analysis.
Mall	Subscribe some extra software or service functions that are not included in the diagnostic tool online.
LAUNCH Academy	Include abundant repair case, operation skills and training videos for quick reference.
Repair Info	Check repair information and ask for support via Facebook or from after-sales team.
User Info	Manage VCI, diagnostic reports & records, change password, order and logout / login etc.
Settings	Make some system settings of diagnostic application.
About	Include software version, product manual, service agreement and privacy policy etc.

4 Connections

4.1 Preparation

1. Make sure that the ignition is turned off and vehicle battery voltage range is 9-14V or 18-30V.
2. Find DLC location.

For passenger cars, the DLC(Data Link Connector) is usually located 12 inches from the center of the instrument panel, under or around the driver's side for most vehicles. For some vehicles with special designs, the DLC location may vary. Refer to the following figure for location.

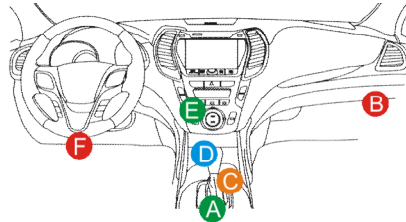

- A. Opel, Volkswagen, Audi
- B. Honda
- C. Volkswagen
- D. Opel, Volkswagen, Citroen
- E. Changan
- F. Hyundai, Daewoo, Kia, Honda, Toyota, Nissan, Mitsubishi, Renault, Opel, BMW, Mercedes-Benz, Mazda, Volkswagen, Audi, GM, Chrysler, Peugeot, Regal, Beijing Jeep, Citroen and other most popular models

If the DLC cannot be found, refer to the vehicle's service manual for the location.

For commercial vehicles, the DLC is always located in driver's cab.

3. Refer to Chapter 4.2 to make connection.
4. Turn the vehicle' ignition ON with engine OFF.
5. Now the tool is ready for diagnostics.

4.2 Vehicle Connection

The method used to connect the VCI device to a vehicle's DLC depends on the vehicle's configuration as follows:

For OBD II vehicles, use the included diagnostic cable (DB15F to HD15F data cable and HD15M to OBD16 adaptor) to connect the VCI to the vehicle's DLC port.

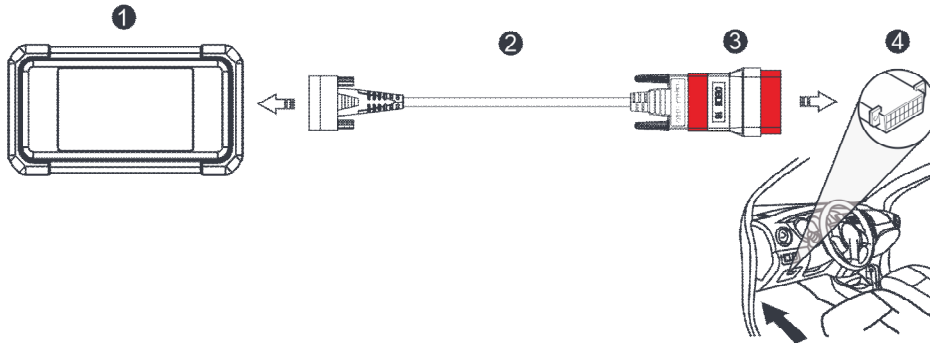

1. VCI
2. DB15F to HD15F data cable
3. HD15F to OBD16 adaptor
4. Vehicle's DLC port

For non-OBDII vehicles, refer to the above figure to make connection.

1. Select the appropriate adaptor according to the vehicle's DLC port type (4).
2. Loosen the captive screws of the DB15F to HD15F data cable (2) and disconnect the HD15F to OBD16 adaptor (3) from the data cable.
3. Connect the data cable (2) with the target adaptor (sold separately) on the above figure and tighten the screws. Other steps shall also apply.

If you choose to perform vehicle diagnosis via data cable, connect one end of the data cable into the VCI, and the other end into the data I/O port of the tablet.

4.3 Communication Setup

There are two kinds of ways available for the tablet to communicate with the VCI device: wireless and wired (USB).

After the user registration is successfully finished, the wireless communication between the tablet and the VCI device is automatically established and user has no need to configure it again.

The USB connection is a simple & quick way to establish communication between the tablet and the VCI. After properly connecting the data cable from the tablet to the VCI, the VCI navigation button at the bottom of the screen will be enabled indicating the USB connection is successful.

Note: The USB connection provides the most stable and fastest communication. When all communication methods are applied at the same time, the tablet will use the wired communication as the default priority.

5 Diagnosis

5.1 Intelligent Diagnose

Through simple wireless communication between the display tablet and VCI, you can easily get the VIN (Vehicle Identification Number) information of the currently identified vehicle. After the VIN is successfully decoded, the system will retrieve it from the remote server and then guide you to vehicle information page without the necessity of step-by-step manual menu selection.

The vehicle information page lists all historical diagnostic records of the vehicle, which lets the technician have a total command of the vehicle faults. In addition, a quick dial to local diagnose and diagnostic function are also available on this page for reducing the roundabout time and increasing productivity.

*Notes:

- Before using this function, please make sure the VCI device is properly connected to the vehicle's DLC. For detailed connection, see Chapter 4.2.
- A stable network connection is required for this function.

Follow the steps below to proceed.

1. Tap **Intelligent Diagnose** on the Job menu screen to start pairing with the VCI device.
2. After pairing is complete, the tablet starts reading the vehicle VIN.

A. If the VIN can be found from the remote server database, the following screen will appear:

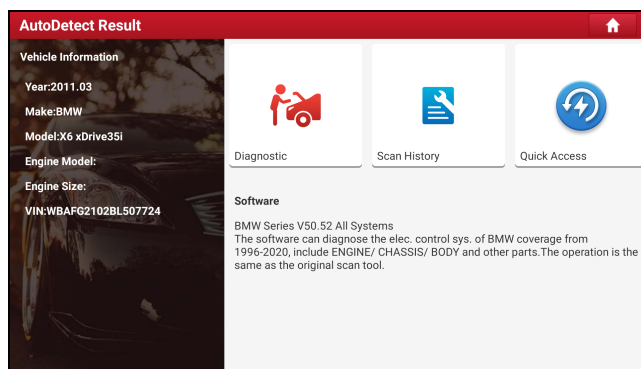

- Tap **Diagnostic** to start a new diagnostic session.
- Tap **Scan History** to view its historical repair record. If there are records available, it will be listed on the screen in sequence of date. If no records exist, the screen will show "No Record."
- To perform other functions, tap **Quick access** to directly go to the diagnostic function selection screen. Choose the desired one to start a new diagnostic session.



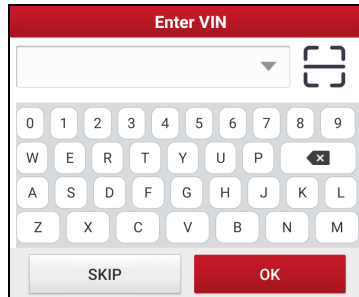

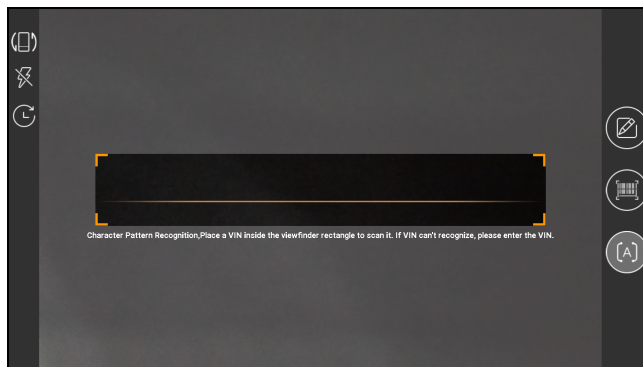

B. If the handset failed to access the VIN information, the following screen will appear:



- Tap the input field to directly, tap **OK**. If the VIN exists on the remote server, the system will enter the diagnostic function selection screen.
- Tap  to launch the VIN recognition module.



Place the VIN inside the viewfinder rectangle to scan it. The most recognizable location for this number is in the top left corner on the vehicle's dashboard. Other locations include the driver's door or post, and the firewall under the hood.

- Tap  to switch the display mode of the screen.
- Tap  to turn the camera flash on.
- Tap  to choose it from the record list if the VIN of the vehicle has been scanned before.
- Tap  to input the VIN manually if the tablet has failed to decode the VIN of the vehicle.
- Tap  to scan the VIN barcode.
- Tap  to scan the VIN character.

*Note: In general, vehicle identification numbers are standardized - all contain 17 characters. VIN characters may be capital letters A through Z and numbers 1 through 0; however, the letters I, O and Q are never used in order to avoid mistakes of misreading. No signs or spaces are allowed in the VIN.

After scanning, the screen automatically displays the result.

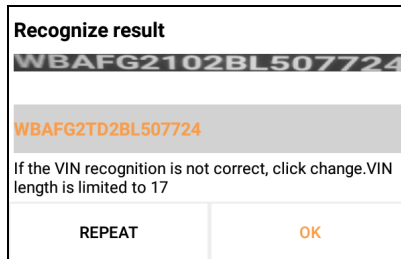

If the VIN scanned is incorrect, tap the result field to modify it and then tap **OK**. To scan it again, tap **REPEAT**. If the VIN exists on the remote server, the system will enter the diagnostic function selection screen.

5.2 Local Diagnose

This function allows you to diagnose electronic control systems of single vehicle models by manually executing the menu-driven command.

Tap **Local Diagnose** to enter the vehicle selection page.

2 approaches are provided for you to access the vehicle diagnostic software. Choose any one of the following ways:

1. VINSCAN enables you to access it more quickly. In this case, Camera Scan and Enter VIN are available.

Camera Scan: Scan the VIN automatically.

Enter VIN: Input the vehicle VIN manually.

If the tablet successfully identifies the vehicle model, it will directly enter the diagnostic function selection menu.

2. Tap a corresponding diagnostic software logo, and then follow the on-screen instruction to access the diagnostic software.

Take Demo (Version 15.51) as an example to demonstrate how to diagnose a vehicle.

- 1). Select diagnostic software version: Tap the **DEMO** to go to Step 2.

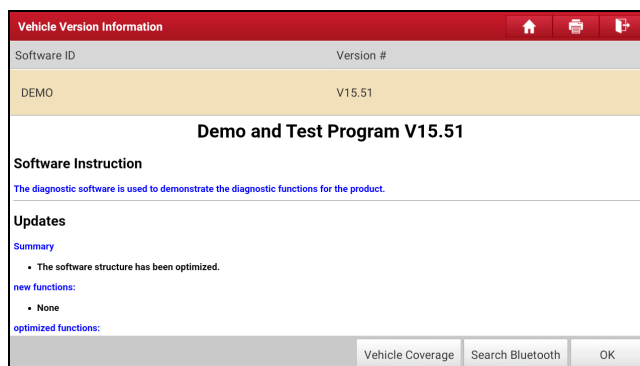

On-screen Buttons:

Vehicle Coverage: Tap to view the vehicle models that the current diagnostic software covers.

Search Bluetooth: Tap to search for the available VCI.

Note: No Bluetooth connection is required for DEMO program.

OK: Tap it to go to next step.

- 2). Select vehicle model. Here we take **TOYOTA** for example to demonstrate how to diagnose a vehicle.
- 3). Select the desired test item to proceed.

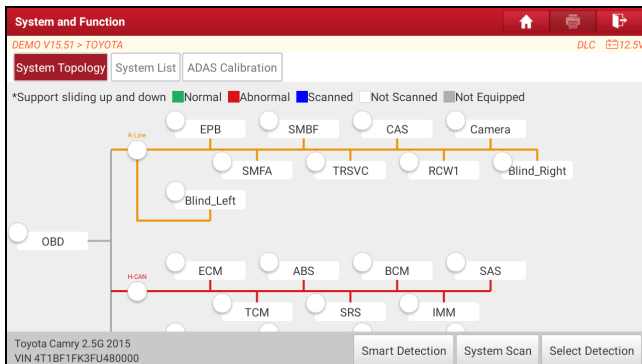

System Topology: Displays all available vehicle systems in form of topology structure.

System List: Displays all available vehicle systems in form of list.

ADAS Calibration: Performs ADAS calibration operations. It is extracted from the system list as a functional module and provides a quick access to ADAS system.

- While in System Topology mode, different highlight bars indicate different detection status.

On-screen Buttons:

Smart Detection: Tap to quickly access all the electronic control units of the vehicle and generate a detailed report about vehicle health. The tested systems malfunctioning are displayed in red with a number indicator displaying DTC quantity and the systems with functioning properly are displayed in green.

Note: Diagnostic Trouble Codes or Fault Codes can be used to identify which engine systems or components that are malfunctioning. Never replace a part based only on the DTC definition. Retrieving and using DTCs for troubleshooting vehicle operation is only one part of an overall diagnostic strategy. Follow testing procedures (in vehicle’s service manual), instructions and flowcharts to confirm the locations of the problem.

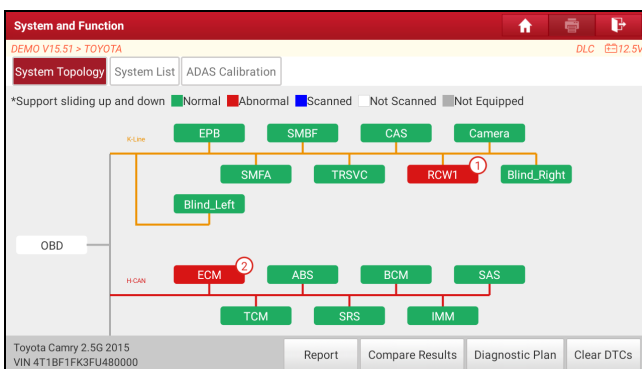

- **Report:** Tap to save the current data in text format. All reports are saved in **User Info -> My Report -> Health Reports**.

 Notes:

1. Diagnostic report is classified into two categories: Pre-Repair report and Post-Repair report. To facilitate



the comparison of the pre-repair and post-repair reports and get accurate test result, please make sure you saved the right type of the diagnostic report.

2. By default, the workshop information is blank. You can configure and revise it from User Info -> Settings -> Shop Information. After you configured the information, it will be automatically generated every time the diagnostic report is saved. All vehicle and workshop information will be appended as a tag on the diagnostic report, which allows you to easily retrieve the desired report while performing Filter function of Diagnostic Report.

- **Compare Results:** Tap to select the pre-repair report to compare. By comparison of the pre- and post- repair reports, you can easily identify which DTCs are cleared and which remain unfixed.

DTC	Post	Pre
Engine		
P2118 Throttle Actuator 'A' Control Motor Range/Performance	Cleared	Found
P0504 Brake Switch A/B Correlation	Cleared	Found
Radar Cruise 1		
C1521 CAN bus:Signal Failure	Cleared	Found

Note: Before performing this function, please make sure that: 1) You have saved a pre-repair report of the currently tested vehicle; and 2) You have already made some repairs and service and cleared the DTCs after the pre-repair reported is generated. Otherwise, no differences exist between the pre- and post- repair reports.

- **Diagnostic Plan:** Figures out the diagnostic plan and repair solutions for the detected DTCs.
- **Clear DTCs:** Tap to clear the existing diagnostic trouble codes.

Note: Clearing DTCs does not fix the problem(s) that caused the code(s) to be set. If proper repairs to correct the problem that caused the code(s) to be set are not made, the code(s) will appear again and the check engine light will illuminate as soon as the problem that cause the DTC to set manifests itself.

System Scan: Tap to quickly scan which systems are installed on the vehicle.

Select Detection: Select certain system manually to start scanning.

- While in System List mode, the following screen will appear.

System	Status	Action
Engine	Not Scanned	Enter
Transmission	Not Scanned	Enter
ABS/VSC/TRAC/EPB	Not Scanned	Enter
SRS Airbag	Not Scanned	Enter
Main Body	Not Scanned	Enter

- **Enter:** Select certain system, and tap this button to enter the diagnostic function selection screen.

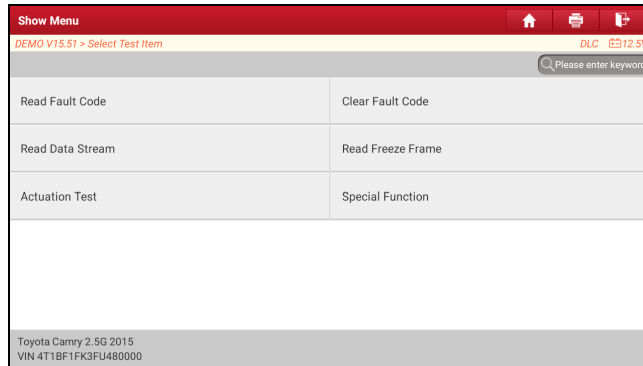

In general, the diagnostic functions vary with different vehicle models. It mainly includes the following options:

A. Read Fault Code

This function displays the detailed information of DTC records retrieved from the vehicle's control system.

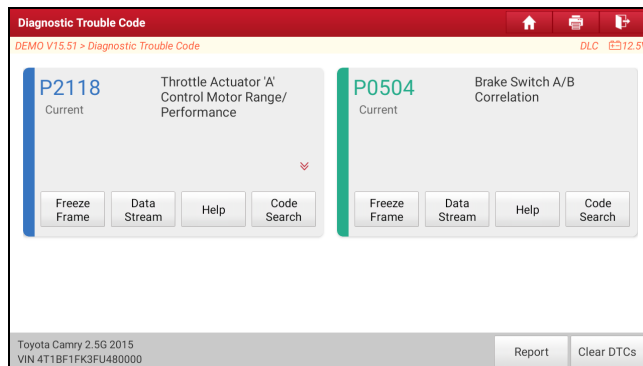

On-screen Buttons:

Freeze Frame: Tap it to view the snapshot of critical parameter values at the time the DTC is set.

Help: Tap to view the help information.

Code Search: Tap it to search for more information about the current DTC online.

Report: To save the current data in text format. All reports are saved in **User Info -> My Report -> Health Reports**.

Clear DTCs: Tap to clear the existing diagnostic trouble codes.

B. Clear Fault Code

This option can erase the codes from the vehicle. Before the operation, please make sure the vehicle's ignition key is in the ON position with the engine off.

Note: After clearing, you should retrieve trouble codes once more or turn ignition on and retrieve codes again. If there are still some trouble codes in the system, please troubleshoot the code using a factory diagnosis guide, then clear the code and recheck.

C. Read Data Stream

This option retrieves and displays live data and parameters from the vehicle's ECU.

Caution: If you must drive the vehicle in order to perform a troubleshooting procedure, ALWAYS have a second

person help you. Trying to drive and operate the diagnostic tool at the same time is dangerous, and could cause a serious traffic accident.

Tap **Read Data Stream**, the following screen will appear:

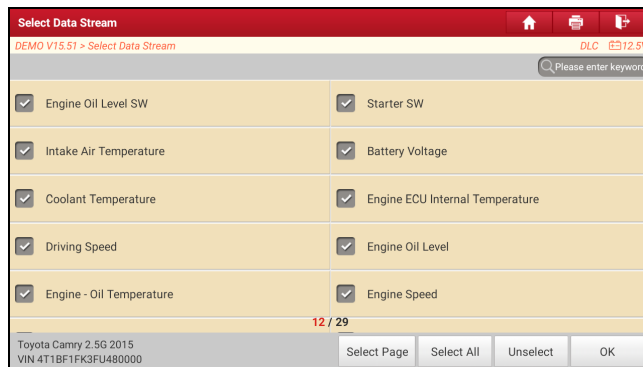

After selecting the desired items, tap **OK** to enter the data stream reading page.



Notes:

1. Tap to set the display style. indicates sticky top. If it is tapped, it will change into . On the data stream display screen, the data stream item with will be shown on the top of the selected data stream list. To remove it from the top of the list, just tap it again.

B indicates this item will be displayed in **Bold**.

A indicates this item will be displayed in Red.

2. Tap **English** or **Metric** to switch the measurement unit.

3. If the value of the data stream item is out of the range of the standard (reference) value, the whole line will display in red. If it complies with the reference value, it displays in blue (normal mode).

There are 3 types of display modes available for data viewing, allowing you to view various types of parameters in the most suitable way.

- Value – this is the default mode which displays the parameters in texts and shows in list format.
- Graph – displays the parameters in waveform graphs.
- Combine – this option is mostly used in graph merge status for data comparison. In this case, different items are marked in different colors.

On-screen Buttons:

: Tap it to view the live waveform.

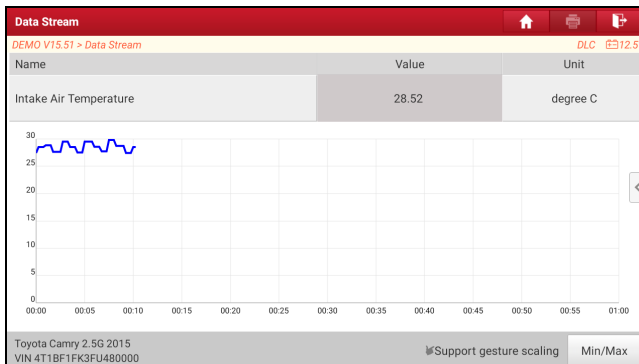

Graph: Tap it to view the waveform of the selected data streams. Tap on the edge of the screen to customize the target data streams for displaying.

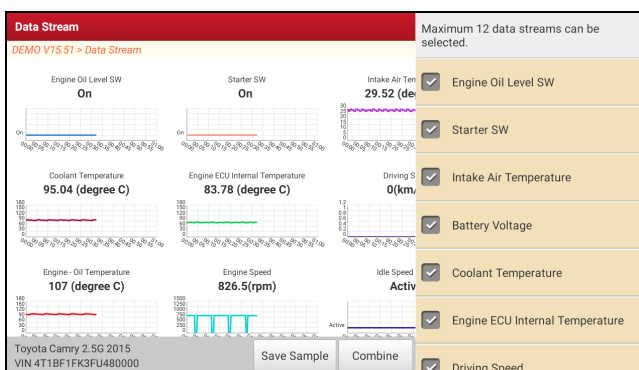

Compare Sample: Tap it to select the sample data stream file, the values you customized and saved in process of data stream sampling will be imported into the **Standard Range** column for your comparison.

Note: Before executing this function, you have to sample the values of data stream items and save it as a sample data stream file.

Report: To save the current data in text format. All reports are saved in **User Info -> My Report -> Health Reports**.

Record: Tap to start recording diagnostic data. Recorded live data can serve as valuable information to help you in troubleshooting of vehicle problems. All recorded files are stored in **User Info -> My Report -> Recorded Data**.

Help: Tap to view the help information.

Save Sample: This item enables you to customize the standard range of live data stream items and save it as sample file. Each time you run the data stream items, you can call out the corresponding sample data to overwrite the current standard range.

Tap it to start recording the sample data (Note: Only data stream items with units will be recorded). Once recording is complete, tap to stop it and navigate to the data modification screen.



Confirm Sample DS			
DEMO V15.51 > Data Stream			DLC 12.5V
Name	Min Value	Max Value	Unit
Battery Voltage	11.56	11.96	V
Coolant Temperature	93.04	97.04	degree C
Driving Speed	0.0	0.0	km/h
Engine - Oil Temperature	104.0	109.0	degree C
Engine ECU Internal Temperature	80.78	83.78	degree C

Toyota Camry 2.5G 2015
VIN 4T1BF1FK3FU480000

Save

Tap the value to change it. After modifying all desired items, tap **Save** to save it. All data stream files are stored in **User Info -> Sample**.

D. Read Freeze Frame

This option takes the snapshot of the operating conditions when a vehicle fault occurs.

E. Actuation Test

This option is used to access vehicle-specific subsystem and component tests. Available test vary by vehicle manufacturer, year, and model.

During the actuation test, the tablet outputs commands to the ECU in order to drive the actuators, and then determines the integrity of the system or parts by reading the ECU data, or by monitoring the operation of the actuators, such as switching a injector between two operating states.

F. Special Functions

This option offers coding, reset, relearn and more service functions, to help vehicles get back to functional status after repair or replacement. Available tests vary by vehicle manufacturer, year, and model.

5.3 Remote Diagnose

5.3.1 SmartLink Super Remote Diagnostics

SmartLink is a newly developed powerful service system dedicated to remote vehicle diagnosis and service. In the SmartLink ecology system, if a technician (SmartLink C) does not have time to puzzle through a tough vehicle problem, he can seek a trusted second opinion or additional expertise on various vehicle issues from remote master technicians or repair shops (SmartLink B). SmartLink B enables the shop owner to greatly increase customer’s retention and boost shop revenue by providing professional technical assistance service.

It mainly consists of the following parts:

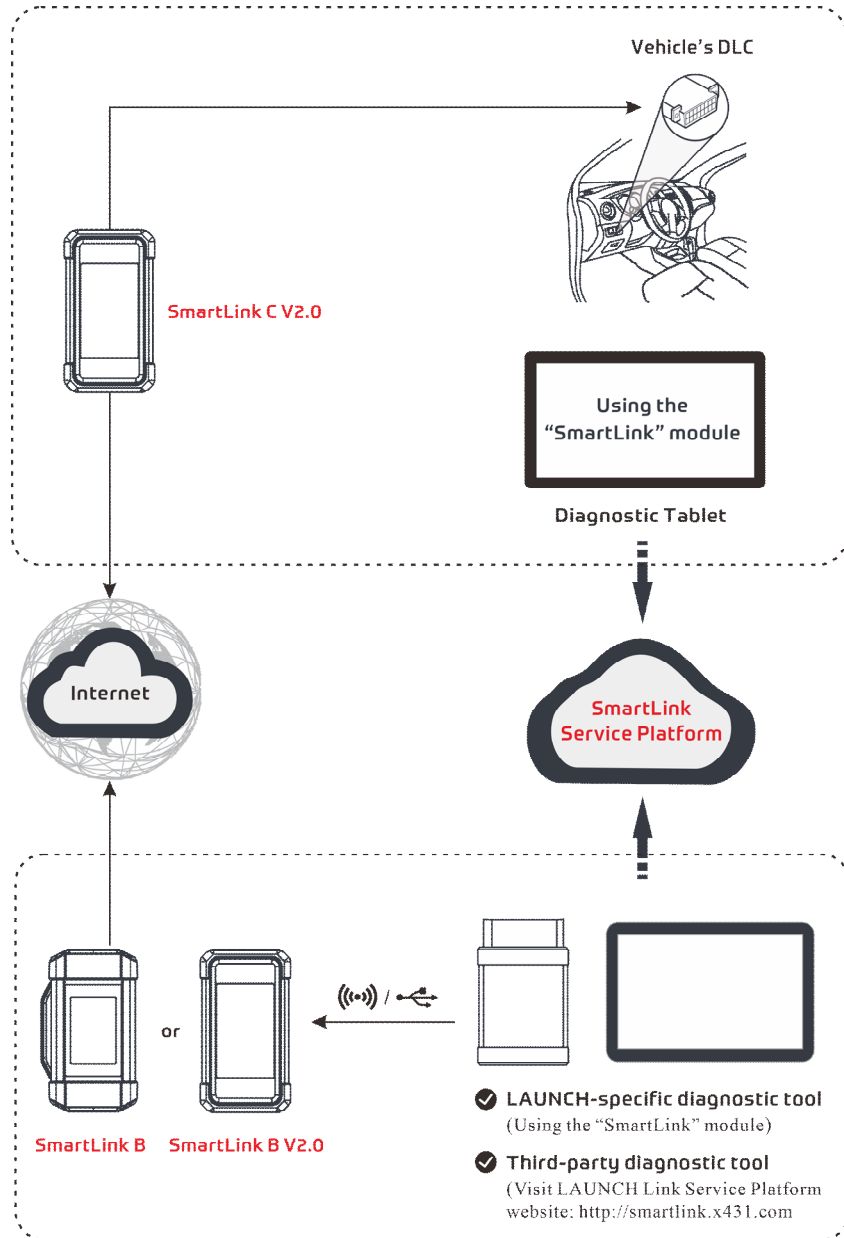

- **SmartLink Service Platform** – It can be accessed from the **SmartLink** module of the diagnostic tablet. There are two modules available on the link service platform: **Common user** (for SmartLink C) and **Service provider** (for SmartLink B).
 - **SmartLink C (Customer) - SmartLink Service Subscriber.** In the SmartLink system, the SmartLink C needs to perform the following operations.
 - 1). Launch Service Link Platform: Binds SmartLink C dongles and submits remote repair orders.
 - 2). SmartLink C Dongle: Connects to the vehicle’s DLC port for collecting the vehicle data and sends it to the remote SmartLink B.
- It supports remote diagnostic services for vehicles that meet CAN / CAN FD / J2534 vehicle

diagnostic standards.

- **SmartLink B (Business) - SmartLink Service Provider.** In the SmartLink system, the SmartLink B needs to perform the following operations.
 - 1). Launch Service Link Platform: Binds SmartLink B dongles and accepts orders from SmartLink C.
 - If the SmartLink B dongle works with the LAUNCH-specific diagnostic tool equipped with SmartLink module, tap **SmartLink** to add the SmartLink B device and accepts orders on the diagnostic tool.
 - If the SmartLink B dongle works with the third-party diagnostic tool, open the browser and visit SmartLink Service Platform website <http://smartlink.x431.com> (web client) to add the SmartLink B device and accepts orders in the browser.
 - 2). SmartLink B Dongle: After accepting the orders, it can work with the compatible diagnostic tool to perform diagnosis of the vehicle connected to the SmartLink C dongle.

For more detailed operations, refer to the User Manual integrated in the SmartLink Platform.

5.3.2 X431 Remote Diagnostics

This option aims to help repair shops or technicians launch instant messaging and remote diagnosis, making the repair job getting fixed faster.

Tap **Remote Diagnose -> X431 Remote Diagnosis** to enter the following screen.

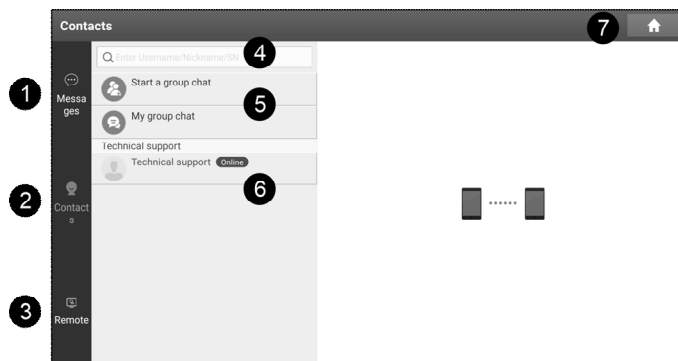

1	Messages tab	Once an incoming message reaches, a red dot will appear on the upper right corner of the tab.
2	Contacts tab	Tap to enter the friend list.
3	Remote	Tap to slide the switch to ON, the tool keeps online and becomes accessible on the web client. In this case, inform the technician of your product S/N, and he/she will control your device remotely.
4	Search bar	Directly input the registered username of the tool to start searching, and then tap the desired one to add it into your friend list.
5	Group chat operation	Used to start a group chat and manage group chat.
6	Contacts list	Displays a list of friends. The technical support is displayed by default if no friends list is created.

7	Home button	Tap it to navigate to the home screen.
---	-------------	--

1. Adding Friends

Tap **Contacts**. By default it appears blank.

In the search bar, input the partner's username and tap **Search** button next to the search bar to start searching.

The partner must be the users who have registered specific diagnostic tools. They may be the following roles:

- Workshop
- Technician
- golo users

Once the result matches the keyword, the following screen will appear:

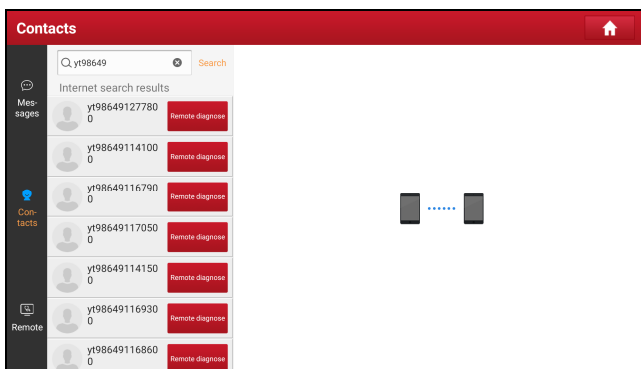

Tap **Remote Diagnose** to launch remote diagnostics directly or follow the steps below to add the partner into the Contacts list.

Tap the desired name from the list, the following screen will appear:

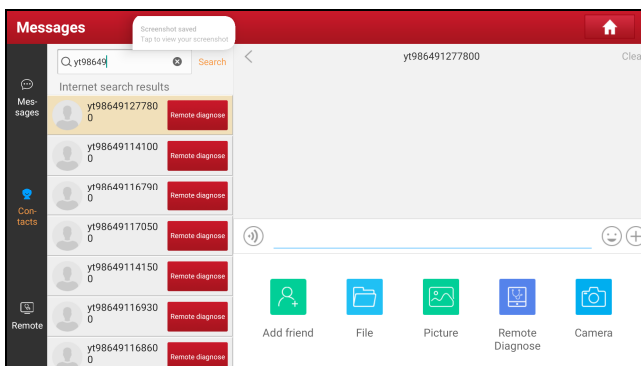

Tap **Add friend** to send your request.

Once the partner receives the request, a beep will sound. Tap **Messages**:

- Once the partner agreed your request, he/she will automatically be listed in the **Contacts** tab.
- If a technician sent you a friend request, tap **Agree** and his/her name will appear in the friend (**Contacts**) list. Or tap **Ignore** to ignore this request.

2. Start Instant Messaging

The I/M (Instant Messaging) function is open to all users who had the diagnostic tool equipped with this module.

After adding your friends, tap the desired one's photo to enter the following screen:

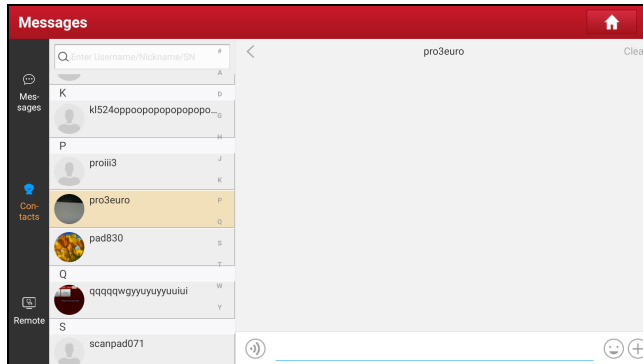

Tap the input field and use the on-screen keyboard to send the text message.

Tap  to send the voice message.

Tap  to send the emoji.

Tap  to call out more function options.

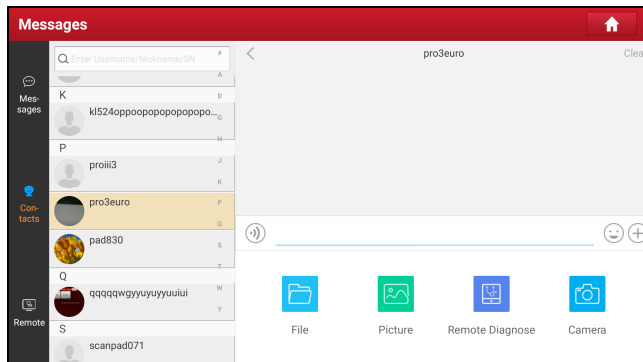

File: Choose diagnostic reports or local files to send.

Picture: Choose screenshots or pictures to send.

Remote Diagnose: To start a remote diagnostic session.

Camera: Open camera to take pictures.

Tap **Clear** to delete all the partner's dialog logs.

3. Launch Remote Diagnosis (Scanner-To-Scanner)

The tool is allowed to initiate remote diagnosis with other diagnostic tools, which are equipped with this module.

On the function option selection screen, tap **Remote Diagnostic**, the following pull-down menu will appear:

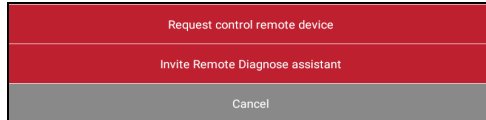

These options are defined as follows:

Actions	Results
<p>Request control remote device</p>	<p>Request to control the partner’s device remotely to help him diagnose the vehicle.</p> <p>Note: Once vehicle diagnosis is complete, a report will be created. Input your comments on this report, and then tap Send Report to send it to the partner.</p> <pre> graph TD A[Tap "Request control remote device"] --> B[Wait for partner's confirmation] B --> C[Start connecting after request confirmed] C --> D[Start Diagnosis] D --> E[Generate diagnostic report] </pre>
<p>Invite remote diagnostic assistant</p>	<p>Use this option to invite a technician to perform a remote control on your tool.</p> <p>Note: Once you received the report from the partner, tap View Report to view details. All diagnostic reports are saved under User Info -> My Report -> Remote Report.</p> <pre> graph TD A[Tap "Invite remote diagnostic assistant"] --> B[Choose the desired diagnostic software] B --> C[Wait for partner's confirmation] C --> D[Start connecting after request confirmed] D --> E[Start Diagnosis] E --> F[Generate diagnostic report] </pre>



Cancel	To cancel this operation.
--------	---------------------------

4. Launch Remote Diagnosis (Scanner-To-PC)

User also can ask for remote control from a PC client technician.

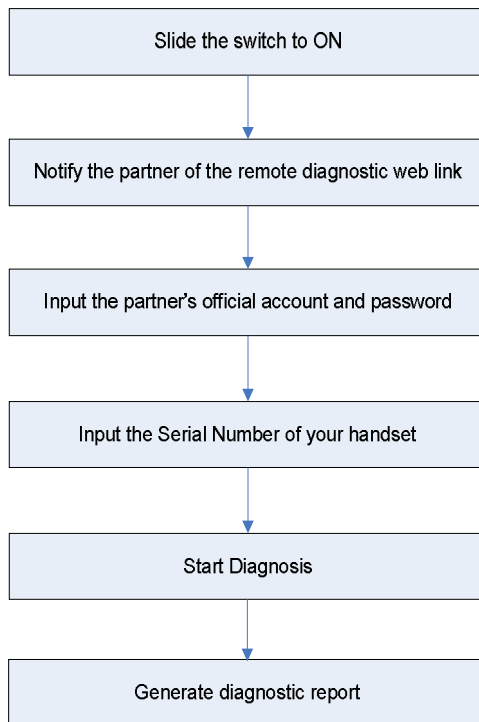

Tap **Remote**, the following screen will appear:

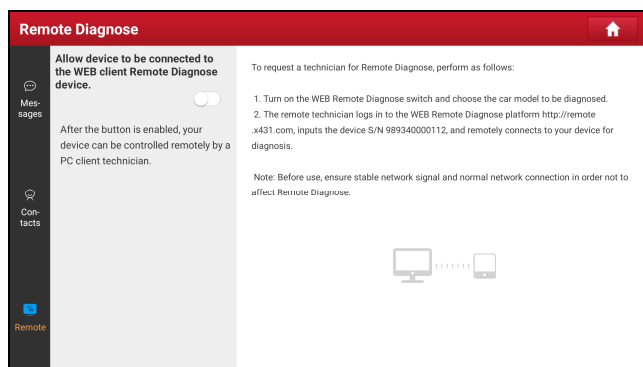

1. Slide the switch to ON so that the partner can find and connect to this device while using the PC.
2. Choose the car model to be diagnosed.
3. Notify the partner of the PC client website <http://remote.x431.com>. When the partner accesses the link, the PC displays as below:

Note: Before processing remote diagnosis, please make sure the tool is properly connected to the vehicle.

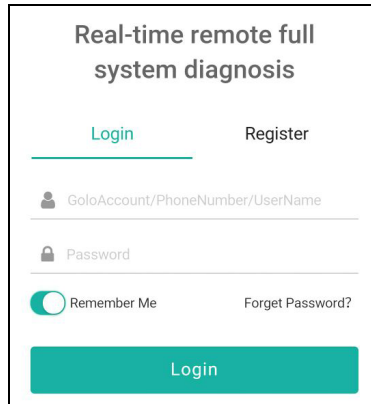

4. Tell the partner to input his own official technician account and password, and then tap **Login** to navigate to the following figure.

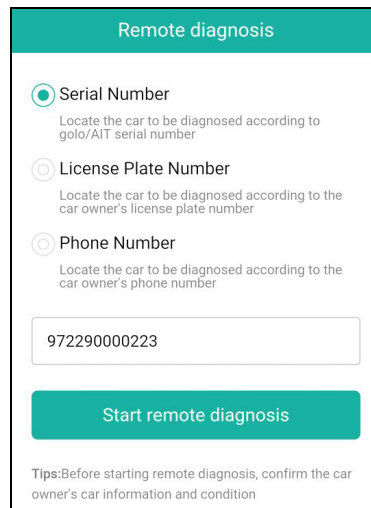

5. Tell the partner to check the box **Serial number** and enter the Serial Number provided by you, and then tap **Start remote diagnosis** to control your device remotely.

In process of remote diagnosis, please note the following things:

- 1) You are not suggested to execute any actions.
- 2) The partner is not allowed to save any diagnostic reports or records on your tool.

The operations in remote diagnosis are same as those in local diagnose. Once the session is complete, a remote diagnostic report will be automatically generated.

5.4 EV (Electric Vehicle) Diagnose

This function only applies to the new energy vehicles. There are two function modules available: Vehicle diagnosis and battery pack detection.

Note: This function needs to work with New Energy Vehicle Diagnosis Add-on Kit (optional), which can be purchased from the authorized dealer.

5.4.1 Vehicle Diagnosis

This function is specially designed to manually diagnose electronic control systems of single new

energy vehicle. Operations of this function are same as those in local diagnose. Refer to Chapter 5.2 for details.

5.4.2 Battery Pack Detection

This function can detect the battery pack of new energy vehicles. Two methods are provided for selecting the battery pack: via vehicle model and via battery brand.

Take BYD E5 as an example to demonstrate how to detect battery pack.

1. Tap **Battery Pack Detection**.
2. Tap **BYD -> E5**.
3. Choose the desired BMS model to enter the following screen.

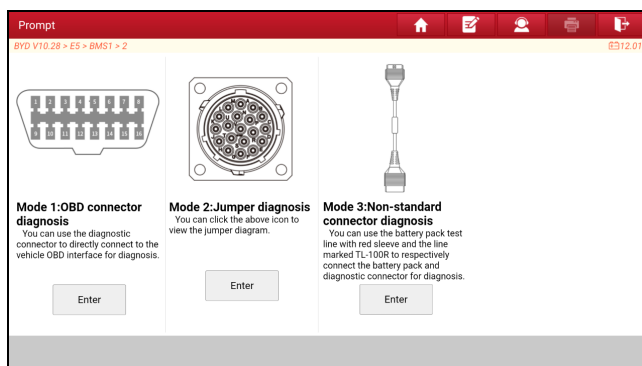

4. Select the preferred detection mode to start the detection until the system outputs the test result.

Note: The available detection mode varies with the vehicle model/battery brand. Generally the following modes are provided:

Mode 1: Via OBD diagnostic interface

Refer to Chapter 4.2 to make connection.

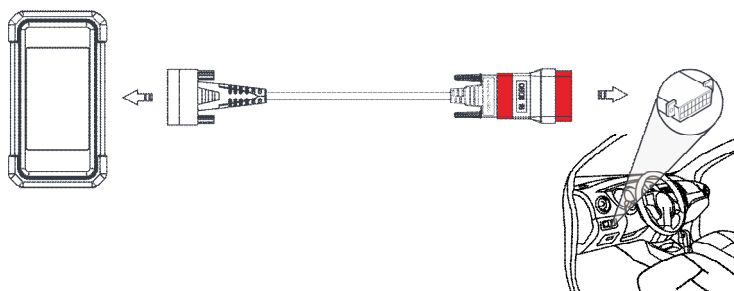

Mode 2: Via Jumper

1. Connect one end of the diagnostic cable to the DB15 diagnostic connector of the SmartLink C V2.0 device, and the other end to OBD-16 connector of the Jumper-8 line (sold separately).
2. Tap the icon shown on the screen to view the detailed connection prompts. Follow the onscreen instructions to connect the electronic control converter line (sold separately), diagnostic interface of battery pack and the Jumper-8 line (Each pin of Jumper-8 line has clear signal definition).
3. It is suggested that SmartLink C V2.0 device is connected to an external power source.

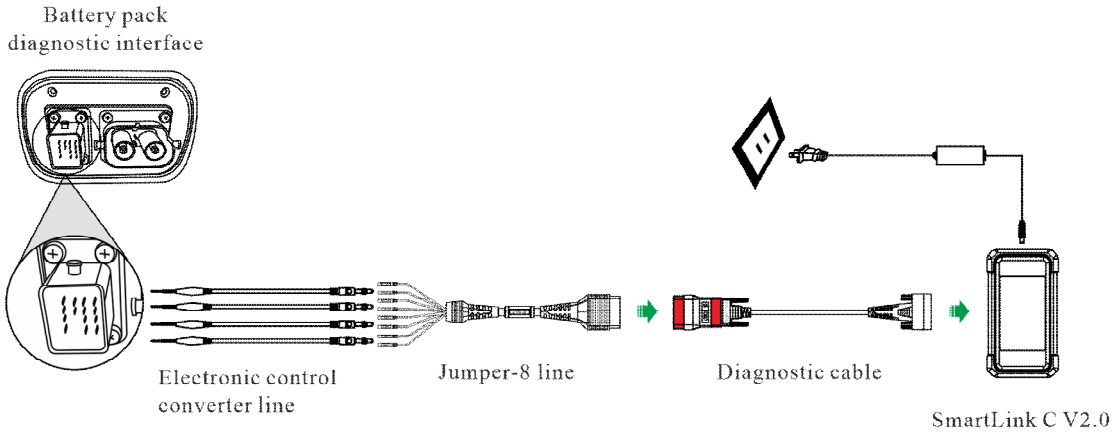

Mode 3: Via Specific test adaptor

1. Connect one end of the diagnostic cable to the DB15 diagnostic connector of the SmartLink C V2.0 device, and the other end to OBD-16 connector of the specific test adaptor (sold separately).
2. Plug the other end of the specific test adaptor to the diagnostic socket of the battery pack.
3. It is suggested that SmartLink C V2.0 device is connected to an external power source.

The specific test adaptor for battery pack varies with vehicle models/battery brands and the screen will prompt corresponding test adaptor model for current test.

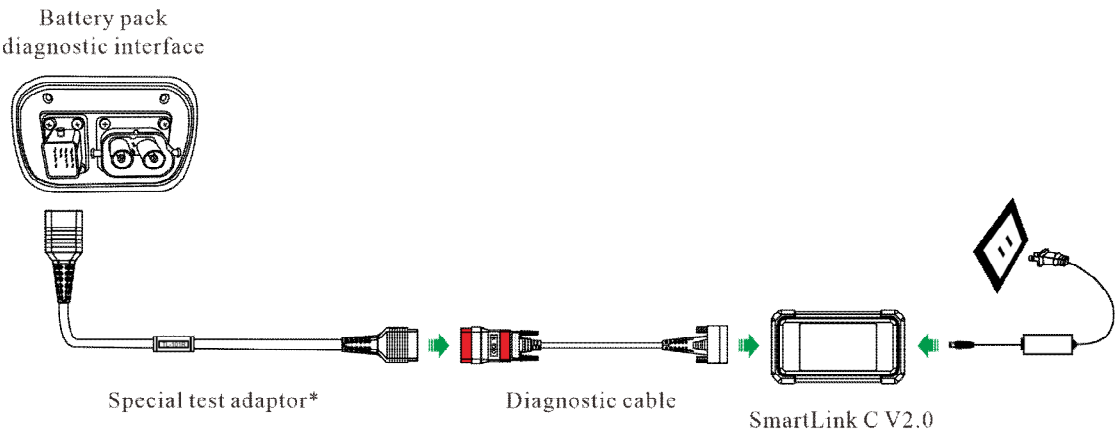

5.5 Feedback

This function enables you to send the feedback of your diagnostic problems to us for further analysis and troubleshooting.

There are 3 options:

- 1). Feedback: To send a tested vehicle diagnostic feedback.
- 2). History: To view all diagnostic feedback records.
- 3). Offline list: To view all diagnostic logs that have failed to be submitted, which will be uploaded again to the remote server automatically once the tablet gets the stable network.

5.6 Diagnostic History

This function enables users to directly get access to the previously tested vehicle's diagnostic records

in details, so users can resume from the last operation, without starting from scratch.

Tap **Diagnostic History** on the Job menu screen, all diagnostic records will be listed on the screen in date sequence.

6 Service Function (Reset)

It offers coding, reset, relearn and more service functions, to help vehicles get back to functional status after repair or replacement. Available tests vary by vehicle manufacturer, year, and model.

Due to continuing improvements, the available service functions are subject to change at any time. To enjoy more service functions, you are suggested to check for updates on a regular basis.

There are two methods to reset service lamp: Manual Reset or Auto Reset. Auto Reset follows the principle of sending command from the tool to vehicle's ECU to do resetting. While using Manual Reset, users just follow the on- screen instructions to select appropriate execution options, enter correct data or values, and perform necessary actions, the system will guide you through the complete performance for various service operations.

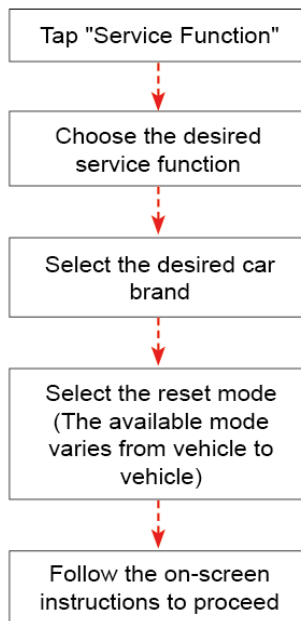

7 Software Update

This module enables you to update the diagnostic software & App and frequently used software.

7.1 Update Diagnostic Software & APP

Go to **Software Update** on the Job Menu and tap the **Downloaded** tab.

The **Available** tab displays a list of software that can be updated. Under it, all software is categorized into three kinds:

- **Common software:** mainly includes some common apps that are associated with the diagnostic app. The software of this kind always stays at the top of the list, which can be deselected manually (excluding the system app, such as firmware and ECU aid).
 - **Frequently used vehicle software:** refers to the diagnostic software that is frequently used, including the vehicle diagnostic software and Reset software. It is generally displayed following the **Common software** list.
 - **Other vehicle software:** refers to the diagnostic software that is rarely used or never used. It is generally displayed following the **Frequently used software** list.
- 1). If the user does not download any diagnostic software during the sign-up process, all diagnostic software is selected by default. Tap **Update** to start downloading.
 - 2). If the user downloaded all/some vehicle software during the sign-up process and had it serviced for a long period of time, only the frequently used software is selected. Tap **Update** to start downloading. Other vehicle software that is rarely used will also be listed under the **Available** tab, but it is not selected at default.

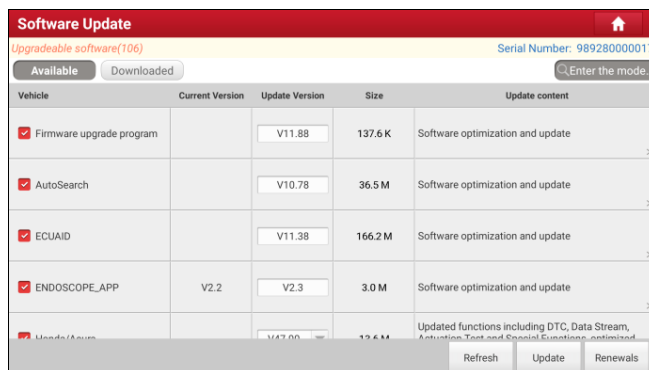

To download certain software that is not frequently used, check the box before the vehicle model. Tap **Update** to start downloading it.

After downloading is finished, the software packages will be installed automatically.

7.2 Update Frequently Used software

If the user only intends to update the frequently used software, go to **Software Update** and tap the **Downloaded** tab.

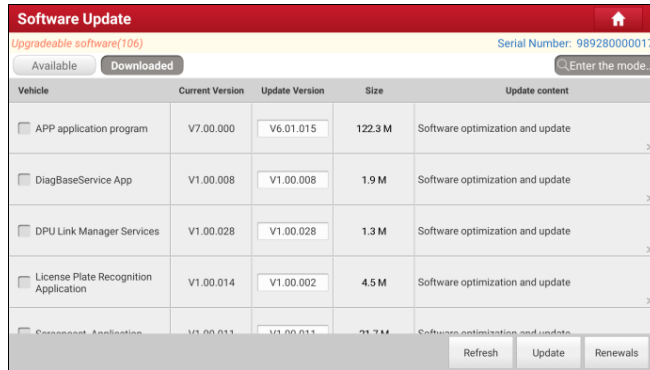

Tap **Update** to start downloading. Once download is finished, the software packages will be installed automatically.

7.3 Renew Subscription

If the software subscription is due or expires, the system will prompt you to renew your subscription. Tap **Renewal** to open the Mall, and then follow the on-screen prompts to finish the subscription.

8 Toolbox

This function includes the following add-on modules: TPMS, ADAS, Oscilloscope, Sensor simulator, BST360 Battery Tester, Immobilizer programmer, Videoscope, Current clamp, Multimeter, Insulation Tester, Key programmer and more.

Each module consists of two parts: hardware and app. These modules cannot work properly on the tablet, which need to work with the specific compatible hardware (sold separately). For detailed operations, refer to the User Manual of each module.

8.1 TPMS

This module allows you to configure the tablet as TPMS activation & diagnostic tool, which provides the ability to trigger TPMS sensor, program TPMS sensor, perform the relearning procedure. It needs to work with the compatible TSGUN device (sold separately).

For more details, please refer to the User Manual included with the module.

8.2 ADAS (Calibration)

This module enables you to effectively and accurately calibrate a wide range of camera-based & radar-based driver assistance systems, e.g. the front camera for the lane departure warning system, the radar sensor for the ACC (Adaptive Cruise Control) or the camera for adaptive headlights. It needs to work with the specific ADAS calibration tool (sold separately).

For more details, please refer to the User Manual included with the module.

8.3 Oscilloscope

This module can make the auto repair technician quickly judge the faults on automotive electronic equipment and wiring. It needs to work with the specific Scopebox (sold separately).

For more details, please refer to the User Manual included with the module.

8.4 Sensor Simulator

This module is specially designed to diagnose and simulator vehicle sensor faults quickly and conveniently. It needs to work with the compatible S2-2 Sensorbox (sold separately).

For more details, please refer to the User Manual included with the module.

8.5 Videoscope

This module allows you to check those unseen parts of engine, fuel tank, and braking system etc. It needs to work with the compatible Videoscope (sold separately).

8.6 BST360 (Battery Tester)

This module allows you to fix battery detection faster and easier. It needs to work with the specific Bluetooth battery tester (sold separately).

For more details, please refer to the User Manual included with the module.

8.7 Multimeter

This module allows you to measure the physical parameters such as voltage, resistance, frequency etc. It utilizes the same hardware as the EM101N.

For more details, please refer to the User Manual included with the EM101N.

8.8 Current Clamp

This module allows you to perform AC/DC current test and DC voltage test for traditional fuel cars and new energy vehicles. It needs to work with the compatible current clamp (sold separately).

For more details, please refer to the User Manual included with the module.

8.9 Insulation Tester

The function enables you to complete the measurement of insulation resistance, voltage and other parameters. It is suitable for users who measure and overhaul on-site power equipment and power supply lines.

For more details, please refer to the User Manual included with the module.

8.10 Immobilizer Programmer

This module allows you to perform the read-write function for vehicle keys, EEPROM, MCU, and EEPROM/FLASH of vehicle engine and gearbox ECU. It needs to work with the specific immobilizer programmer (sold separately).

For more details, please refer to the User Manual included with the module.

8.11 Key Programmer

The function can identify car key chips and generate various types of chip models from super remotes, read the remote control frequency of car keys, and generate remote control devices for different car models from various types of super remotes. It needs to work with the compatible key programmer (sold separately).

For more details, please refer to the User Manual included with the module.

9 Diagnostic Widget

9.1 Vehicle Coverage

Use this item to check which vehicle models are supported on the tool.

9.2 CAN Bus Pin Detection

This function allows you to detect the voltage of the vehicle OBD II diagnostic socket pins and the supported protocol types to help technicians judge the OBD II diagnostic interface.

9.3 CANScope

This item can monitor vehicle CANBUS data and make it visual on the screen. Moreover it can also check the problems existed in the CAN data, assisting you to analyze fault causes.

9.4 Diagnostic Software Clear

This item allows you to hide/clear the diagnostic software that is not frequently used.

 Note: Removing software may completely delete the software from the tablet. If some software is not used and the tablet runs out of space, you can use this feature to remove it. To re-download it, go to **Software Update** -> **Available**.

9.5 Fix Connector Firmware/System

Use this item to upgrade and fix VCI firmware/system. During fixing, please do not cut power or switch to other interfaces.

9.6 Data Stream Sample

This item allows you to manage the recorded data stream sample files.

9.7 DLC Voltage Check

This item performs a check of the vehicle's battery to ensure the system is operating within acceptable limits.

9.8 Reset MSVIN

This item can decode the VIN information of all ECUs installed on test vehicle and output all inconsistent VINs.

9.9 Diagnostic History

When a vehicle diagnosis is performed, the tablet records the detailed diagnostic information. The History function allows access to previously tested vehicle records. Testing can be resumed from the previous operation without starting from scratch.

Tap **Diagnostic History**, all diagnostic records will be listed on the screen in date sequence.

10 User Info

This function allows users to manage personal information and VCI.

10.1 My Report

This option is used to view, delete or share the saved reports.

Tap **Report**, there are total 3 options available.

In case the DTC result is saved on Read Trouble Code page, the files will be listed under **Health Reports** tab.

If user records the running parameters while reading data stream, the tablet will save the file which appears under **Recorded Data** tab.

Remote Reports lists all diagnostic reports generated in process of remote diagnosis.

10.2 VCI

This option allows you to manage all activated VCI devices.

If several VCI devices are activated on this tool, a list of VCIs will be displayed on the screen. Once you choose the VCI device that belongs to other account, you have to log out, and then input the right account to continue.

10.3 Activate VCI

This item lets you activate a new VCI.

10.4 Profile

Use this item to view and configure personal information.

- The profile description includes a 'placeholder' for a user photograph. Tap the user image to change it.
- Tap > next to **Upgrade Period** to check the due date of all diagnostic software.

10.5 My Order

This item allows you to check the status of all your orders.

10.6 Change Password

This item allows you to modify your login password.

10.7 Login/Log out

To logout the current user ID, tap **Log Out**.

To login the system again, tap **Login**.

11 Settings

It enables you to make some application settings and view software version information etc.

11.1 Units

It is designed to configure the measurement unit. Metric System and English System are available.

11.2 Shop information

This option lets you define your print information. It mainly includes Workshop, Address, Telephone, Fax and License Plate.

Once you saved the print information, it will be entered automatically in the “Add Information” box every time you save the diagnostic report.

11.3 Printer set

This option is designed to establish a wireless connection between the tablet and the Wi-Fi printer (sold separately) while performing printing operations.

The App is compatible with the **LAUNCH Wi-Fi Printer** (sold separately) and **System** (external printer).

For LAUNCH Wi-Fi printer, refer to the User Manual included with the Wi-Fi printer to configure the printer settings.

For other Wi-Fi printers,

Before printing, make sure the following conditions are met:

- The Wi-Fi printer is powered on and working normally.
- The print service plug-in associated with the printer is already installed on the tablet (Go to Google Play or use the Browser to download and install it).

Follow the steps below to proceed:

1. Set the default printer as **System**.
2. Set the Wi-Fi switch to Off.
3. On the report details page, tap .

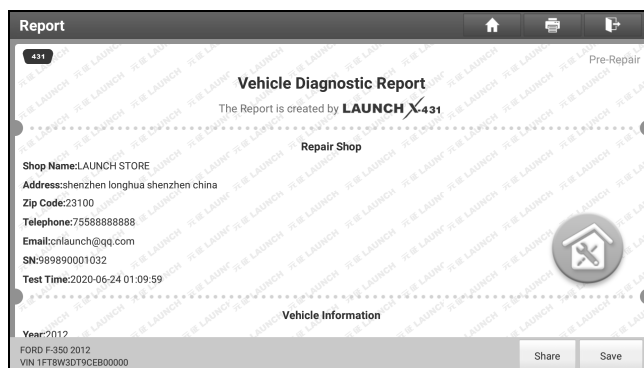

4. Touch ▼ next to **Select a printer** on the upper left corner of the screen.

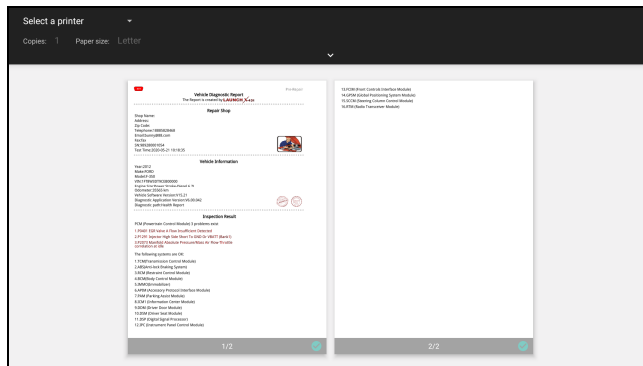

5. Select **All Printers** -> **Add printer** and enable the installed printer service, the system starts searching for all available Wi-Fi printers of the brand.

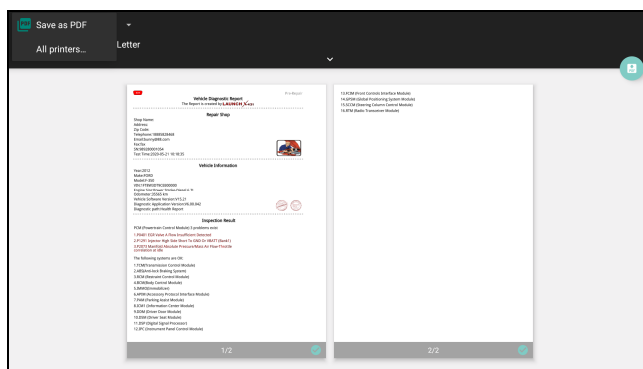

6. Select the desired Wi-Fi printer from the list. If the chosen Wi-Fi printer hotspot is open, the tablet can connect it directly. If it is encrypted, a password may be required. Refer to the Wi-Fi printer user manual to get the default password.
7. Now the printer is ready for printing.
8. Alternatively, you can also choose **Save as PDF** to save the current diagnostic report as a PDF file for later printing.

11.4 Clear cache

This item is used to clear the App cache.

Tap **Clear Cache**, a pop-up window will appear on the screen. Tap **OK** to clear cache and the system will restart the App.

11.5 Diagnostic software auto update

This option is used to set whether automatic update function is ON.

11.6 Device account management

This option is used to manage the authorized technician accounts. The added technician account allows the VCI to be used by different users to log in the tool, which is convenient for multiple VCIs to perform diagnostic service at the same time.

The newly added technician account has a one-year validity period. After the expiration, the VCI bound

to the technician account cannot be used and the technician account will no longer enjoy the rights and interests of the main account. The main account can modify the validity period of the sub-account.

There are two types of technician accounts: one is an existing account and the other is a newly created account. The main account has the functions of adding and removing technician accounts, the technician account can also be unbound from the main account.

Tap **Device account management**, the following screen will appear:

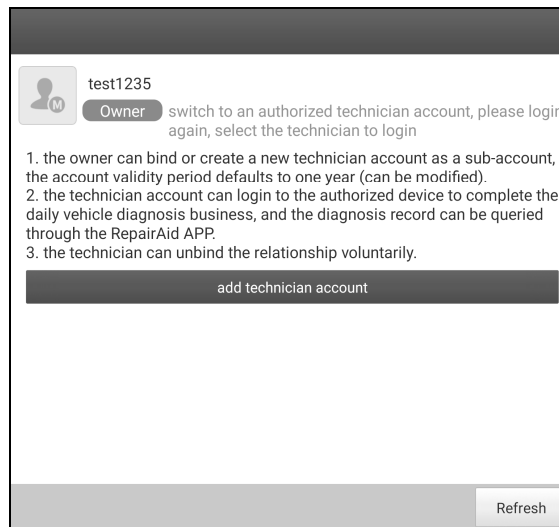

Tap **Add technician account**, the following popup will appear:

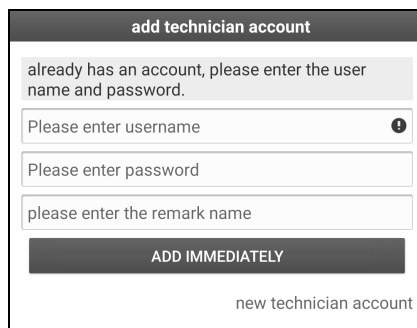

- If you already have an account, please enter the user name and password. After inputting, tap **Add Immediately** to add it as an authorized technician account.
- If you have not registered any account, tap **New technician account**. Enter the user name and password, and then tap **Add Immediately** to add it as a technician account.

The new technician account can login the authorized scanner to complete the daily vehicle diagnosis business, and the diagnosis record can be checked through the RepairAid App (can be downloaded in Google Play).

After adding the technician account, tap **Remove** to unbind it from the main account; tap **Change** to revise the validity period.

12 J2534 Reprogramming

Reprogramming is often the only solution for problems ranging from driveability and loss of power to poor fuel economy and emissions related issues. SmartLink C makes it easy. The SmartLink C is a communication interface supporting J2534 specifications for ECU reprogramming.

Except that the SmartLink C acts as a VCI device and a SmartLink dongle, it also can be used as a J2534 PassThru device, working together with the PC installed with the OEM diagnostic software to perform the J2534 reprogramming. In this case, the PC needs to install with the LAUNCH's J2534 tool, which can be downloaded from <https://en.cnlaunch.com>.

PC installed with OEM
diagnostic software



USB Cable

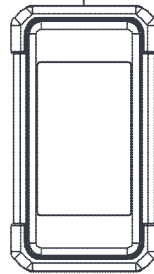
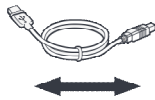

Vehicle's DLC

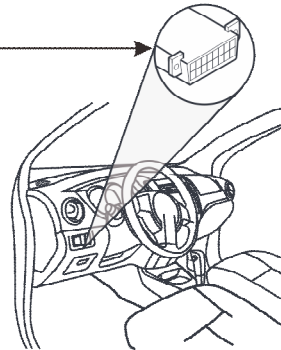

13 FAQ

13.1 About diagnostic tablet

1. How to save power?

1. Please turn off the screen while the tool keeps idle.
2. Set a shorter standby time.
3. Decrease the brightness of the screen.
4. If WLAN connection is not required, please turn it off.

2. Communication error with vehicle ECU?

Please confirm:

1. Whether the VCI device is correctly connected.
2. Whether ignition switch is ON.
3. If all checks are normal, send vehicle year, make, model and VIN number to us using Feedback feature.

3. Failed to enter into vehicle ECU system?

Please confirm:

1. Whether the vehicle is equipped with this system.
2. Whether the VCI device is correctly connected.
3. Whether ignition switch is ON.
4. If all checks are normal, send vehicle year, make, model and VIN number to us using Feedback feature.

4. How to download the diagnostic app after resetting the tablet?

Note: Before registration, please make sure the network is properly connected.

After the tablet has been successfully reset, follow the steps below to download the App:

1. Launch the browser and the default official Launch website opens (If a blank page pops up, just type in www.x431.com in the input bar).
2. Tap **Login**, input the username and password and tap **Log In**.
3. Make sure that the serial number is correct, tap **APP application program** and tap the Download icon to start downloading.
4. After the download is complete, follow the on-screen instructions to install it.
5. After installation, use the existing username and password to login and go to update center to download the diagnostic software.

5. What to do if the language of vehicle diagnostic software does not match the system language?

English is the default system language of the tool. After the system language is set to the preference language, please go to the update center to download the vehicle diagnostic software of the corresponding language.

If the downloaded diagnostic software is still displayed in English, it indicates that the software of the

current language is under development.

6. How to retrieve the login password?

Please follow below steps to proceed in case you forgot the login password:

1. Tap the application icon on the home screen to launch it.
2. Tap **Login** on the upper right corner of the screen.
3. Tap **Retrieve password**.
4. Input product S/N and follow the on-screen prompts to retrieve the password.

13.2 About SmartLink Diag.

1. What's network conditions is required for SmartLink Diag.?

The remote SmartLink Diag. operation requires a network broadband of 100MB or above.

2. What does the word "Delay" displayed on the SmartLink C screen mean?

The Delay (network delay) indicates the state of the network communication, which can be regarded as a reference since different vehicles require different delays. Different colors represent different delay status. There are three states of network delay:

Green: Indicates a shorter network delay. In this case, it has a higher success rate of remote communication.

Yellow: Indicates a medium network delay. In this case, it has a medium success rate of remote communication.

Red: Indicates a longer network delay. In this case, it has a lower success rate of remote communication and remote ECU reprogramming operations are not suggested.

3. My network delay is so long.

Please check the following possible reasons:

1. The greater distance between the SmartLink B2.0/SmartLink B and SmartLink C V2.0 dongle causes a longer network delay.
2. There are too many network communication nodes that the data communication passes by, which may cause a longer network delay.
3. Check if the network is poor and data communication speed is slow.

4. Some systems of some old vehicles cannot be tested

The SmartLink C V2.0 dongle supports CAN2.0/CANFD/DoIP communication protocols, but some old vehicle uses K-Line communication protocol.

5. Is it necessary to re-ignite the car after the diagnostic system starts working?

For the sake of some vehicle's conditions, the re-ignition will provide you a more detailed analysis after OBD diagnosis.

Warranty

THIS WARRANTY IS EXPRESSLY LIMITED TO PERSONS WHO PURCHASE LAUNCH PRODUCTS FOR PURPOSES OF RESALE OR USE IN THE ORDINARY COURSE OF THE BUYER'S BUSINESS.

LAUNCH electronic product is warranted against defects in materials and workmanship for one year from date of delivery to the user.

This warranty does not cover any part that has been abused, altered, used for a purpose other than for which it was intended, or used in a manner inconsistent with instructions regarding use. The exclusive remedy for any automotive meter found to be defective is repair or replacement, and LAUNCH shall not be liable for any consequential or incidental damages.

Final determination of defects shall be made by LAUNCH in accordance with procedures established by LAUNCH. No agent, employee, or representative of LAUNCH has any authority to bind LAUNCH to any affirmation, representation, or warranty concerning LAUNCH automotive meters, except as stated herein.

Disclaimer

The above warranty is in lieu of any other warranty, expressed or implied, including any warranty of merchantability or fitness for a particular purpose.

Purchase Order

Replaceable and optional parts can be ordered directly from your LAUNCH authorized tool supplier. Your order should include the following information:

- Order quantity
- Part number
- Part name

Customer Service

If you have any questions on the operation of the unit, please contact the seller, or customer service center:

Website: <https://en.cnlaunch.com>

Phone: 1-888-756-2936

Email: Tech_Launchoriginal@outlook.com

Statement:

LAUNCH reserves the rights to make any change to product designs and specifications without notice. The actual object may differ a little from the descriptions in the manual in physical appearance, color and configuration. We have tried our best to make the descriptions and illustrations in the manual as accurate as possible, and defects are inevitable, if you have any question, please contact local dealer or after-sale service center of LAUNCH, LAUNCH does not bear any responsibility arising from misunderstandings.