

**SEARS  
OWNER'S  
MANUAL**

**MODEL NO.  
247.799640**

**Caution:  
Read and Follow  
All Safety Rules  
and Instructions  
Before Operating  
This Equipment**

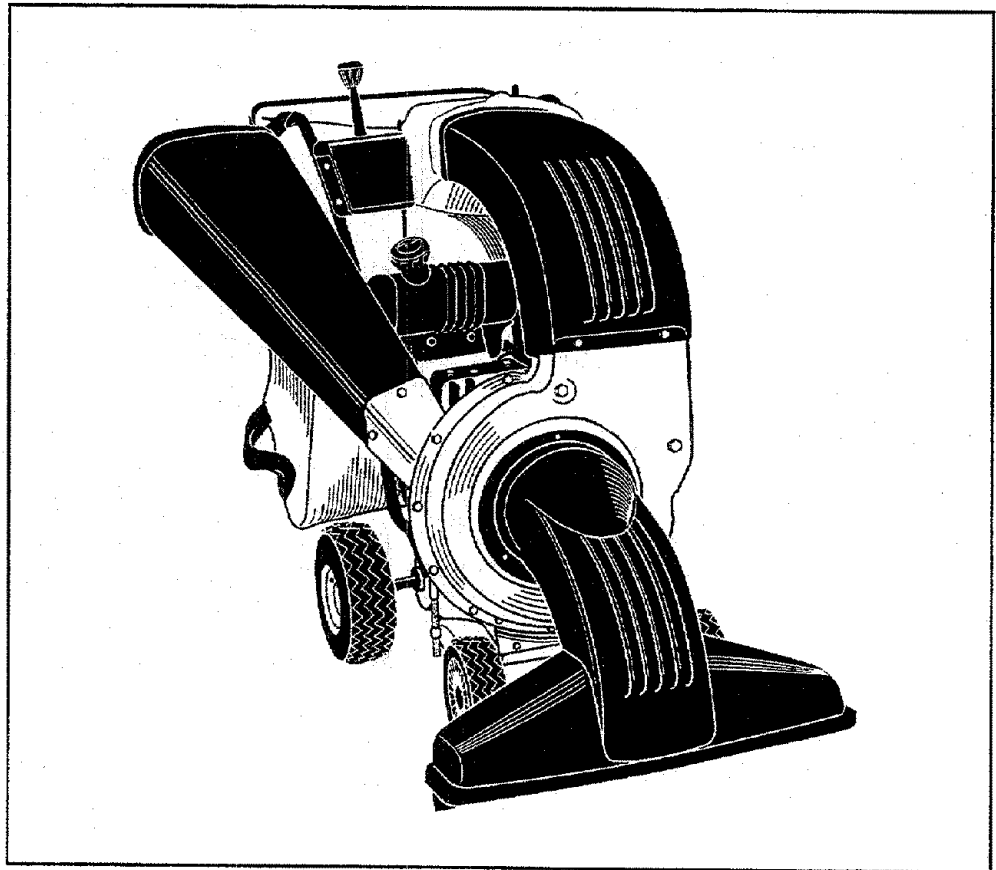

**CRAFTSMAN®**

**9 HORSEPOWER  
MULCHING AND BAGGING  
CHIPPER-VACUUM**

**Assembly  
Operation  
Customer Responsibilities  
Service and Adjustment  
Repair Parts**

**SEARS, ROEBUCK AND CO., Hoffman Estates, IL 60179 U.S.A.**

# IMPORTANT

## SAFE OPERATION PRACTICES



THIS SYMBOL POINTS OUT IMPORTANT SAFETY INSTRUCTIONS WHICH, IF NOT FOLLOWED, COULD ENDANGER THE PERSONAL SAFETY AND/OR PROPERTY OF YOURSELF AND OTHERS. READ AND FOLLOW ALL INSTRUCTIONS IN THIS MANUAL BEFORE ATTEMPTING TO OPERATE YOUR POWER CHIPPER-VACUUM. FAILURE TO COMPLY WITH THESE INSTRUCTIONS MAY RESULT IN PERSONAL INJURY. WHEN YOU SEE THIS SYMBOL—  **HEED ITS WARNING.**



### **DANGER:**

Your chipper-vacuum was built to be operated according to the rules for safe operation in this manual. As with any type of power equipment, carelessness or error on the part of the operator can result in serious injury. This unit is capable of amputating fingers and hands and throwing objects. Failure to observe the following safety instructions could result in serious injury or death.

### **I. GENERAL OPERATION**

- Read this owner's guide carefully in its entirety before attempting to assemble this machine. Read, understand, and follow all instructions on the machine and in the manual(s) before operation. Be completely familiar with the controls and the proper use of the machine before operating it. Keep this manual in a safe place for future and regular reference and for ordering replacement parts.
- Your chipper-vacuum is a powerful tool, not a plaything. Therefore, exercise extreme caution at all times. Your unit has been designed to perform two jobs; to chip and vacuum vegetation found in a normal yard. Do not use it for any other purpose.
- Never allow children under 16 to operate the unit. Children 16 years and older should only operate under close parental supervision. Only responsible individuals who are familiar with these rules of safe operation should be allowed to use your unit.
- Keep the area of operation clear of all persons, particularly small children and pets. Stop the engine when they are in the vicinity of the unit.
- When feeding material into this equipment, be extremely careful that pieces of metal, rocks, bottles, cans or other foreign objects are not included. Personal injury or damage to the machine could result.
- Always wear safety glasses or safety goggles, during operation and while performing an adjustment or repair, to protect eyes from foreign objects that may be thrown from the machine.
- Wear sturdy, rough-soled work shoes and close fitting slacks and shirt. Shirt and slacks that cover the arms and legs and steel-toed shoes are recommended. Do not wear loose fitting clothes or jewelry and secure hair so it above shoulder length. They can be caught in moving parts. Never operate a unit in bare feet, sandals or sneakers. Wear gloves when feeding material in the chipper chute.
- Do not operate the unit while under the influence of alcohol or drugs.
- Do not over-reach. Keep proper footing and balance at all times.
- Never place your hands or any part of your body or clothing near or under rotating parts. Keep clear of the discharge opening at all times. Never insert your hands or any part of your body or clothing into the nozzle, chipper chute or discharge opening as the rotating impeller can cause serious injury.
- If it is necessary for any reason to unclog the feed intake or discharge openings or to inspect or repair any part of the machine where a moving part can come in contact with your body or clothing, stop the machine, allow it to cool, disconnect the spark plug wire from the spark plug and move it away from the spark plug before attempting to unclog, inspect or repair.
- Never operate unit without vacuum bag and discharge chute properly affixed to unit. Large zippered end of bag must be closed to prevent objects from being blown out.

- Never operate unit without either the inlet nozzle or optional hose attachment properly affixed to unit. These devices shield the operator from accidental contact with the rotating impeller. Never attempt to convert the unit from nozzle to hose mode or vice versa with the engine running.
- Never attempt to remove or empty vacuum bag when engine is running. Shut the engine off and wait for the impeller to come to a complete stop before removing the bag. The impeller continues to rotate for a few seconds after the engine is shut off. Never place any part of the body in the impeller area until you are sure the impeller has stopped rotating.
- Keep all guards and safety devices in place and operating properly.
- Do not allow an accumulation of processed material to build up in the discharge area as this will prevent proper discharge and can result in kick-back from the chipper chute.
- Keep your face and body back from chipper chute to avoid accidental bounce back of any material.
- If the cutting mechanism strikes a foreign object or if your machine should start making an unusual noise or vibration, immediately stop the engine, disconnect the spark plug wire and move the wire away from the spark plug. Allow the machine to stop and take the following steps.
  - Inspect for damage
  - Repair or replace any damaged parts.
  - Check for any loose parts and tighten to assure continued safe operation.
- Muffler and engine become hot and can cause a burn. Do not touch.
- Do not allow leaves or other debris to build up on engine's muffler. The debris could ignite and cause a fire.
- Do not operate engine if air cleaner or cover over carburetor air-intake is removed, except for adjustment. Removal of such parts could create a fire hazard.

### **II. CHILDREN**

Tragic accidents can occur if the operator is not alert to the presence of small children. Children are often attracted to the chipping and vacuuming activity. Never assume that children will remain where you last saw them.

- Keep children out of the work area and under the watchful eye of a responsible adult other than the operator.
- Be alert and turn the unit off if a child enters the area.
- Never allow children under the age of 16 to operate the chipper-vacuum.

### **III. SERVICE**

- Use extreme care in handling gasoline and other fuels. They are extremely flammable and the vapors are explosive.
  - Store fuel and oil in approved containers, away from heat and open flame, and out of the reach of children.

- Check and add fuel before starting the engine. Never remove gas cap or add fuel while the engine is running. Allow engine to cool at least two minutes before refueling.
- Replace gasoline cap securely and wipe off any spilled gasoline before starting the engine as it may cause a fire or explosion.
- Extinguish all cigarettes, cigars, pipes and other sources of ignition.
- Never refuel unit indoors because flammable vapors will accumulate in the area.
- Never store the machine or fuel container inside where there is an open flame or spark such as a gas hot water heater, clothes dryer or furnace.
- Never run your machine in an enclosed area as the exhaust from the engine contains carbon monoxide, which is a odorless, tasteless and deadly poisonous gas.
- To reduce fire hazard, keep engine and muffler free of leaves, grass, and other debris build-up. Clean up fuel and oil spillage. Allow unit to cool at least 5 minutes before storing.
- Before cleaning, repairing, or inspecting, make certain the impeller and all moving parts have stopped. Disconnect the spark plug wire and keep wire away from spark plug to prevent accidental starting. Do not use flammable solutions to clean air filter.
- Keep all nuts, bolts, and screws tight to be sure the equipment is in safe working condition.
- Never tamper with safety devices. Check their proper operation regularly.
- After striking a foreign object, immediately stop the engine, disconnect the spark plug wire from the spark plug, and thoroughly inspect the unit for any damage. Repair damage before starting and operating unit.
- Do not alter or tamper with the engine's governor setting. The governor controls the maximum safe operating speed of the engine. Over-speeding the engine is dangerous and will cause damage to the engine and to other moving parts of the machine.
- Check the vacuum bag frequently for wear. Replace if worn or damaged.
- Keep vacuum bag free of debris when not in use.

**OWNER'S  
MANUAL**



**SAFETY LABEL**



**WARNING — YOUR RESPONSIBILITY**

Restrict the use of this power machine to persons who read, understand and follow the warnings and instructions in this manual and on the machine.

**CONGRATULATIONS** on your purchase of a Sears Craftsman Chipper-Vacuum. It has been designed, engineered and manufactured to give you the best possible dependability and performance.

Should you experience any problem you cannot easily remedy, please contact your nearest Sears Service Center/ Department in the United States. We have competent, well-trained technicians and the proper tools to service or repair this unit.

Please read and retain this manual. The instructions will enable you to assemble and maintain your chipper-vacuum properly. Always observe the "SAFETY RULES."

MODEL NUMBER 247.799640
SERIAL NUMBER _____
DATE OF PURCHASE _____
THE MODEL AND SERIAL NUMBERS WILL BE FOUND ON A LABEL ATTACHED TO THE FRAME OF THE CHIPPER-VACUUM.
YOU SHOULD RECORD BOTH SERIAL NUMBER AND DATE OF PURCHASE AND KEEP IN A SAFE PLACE FOR FUTURE REFERENCE.

**CUSTOMER RESPONSIBILITIES**

- Read and observe the safety rules.
- Follow a regular schedule in maintaining, caring for and using your chipper-vacuum.
- Follow the instructions under "Customer Responsibilities" and "Storage" sections of this Owner's Manual.

**PRODUCT SPECIFICATIONS**

Horsepower:	9.0
Engine Oil Capacity: API Classification SF, SG or SH	SAE 30 (26 Ounces)
Fuel Capacity:	Approximately 1 Gallon (Unleaded)
Spark Plug (Gap .030 in.):	Champion J-8C (or Equivalent)
Tire Pressure:	24 p.s.i.

**MAINTENANCE AGREEMENT**

A Sears Maintenance Agreement is available on this product. Contact your nearest Sears store for details.

**WARNING:** This unit is equipped with an internal combustion engine and should not be used on or near any unimproved forest-covered, brush-covered or grass-covered land unless the engine's exhaust system is equipped with a spark arrester meeting applicable local or state laws (if any). If a spark arrester is used, it should be maintained in effective working order by the operator.

In the State of California the above is required by law (Section 4442 of the California Public Resources Code). Other states may have similar laws. Federal laws apply on federal lands. A spark arrester for the muffler is available through your nearest Sears Authorized Service Center (See the REPAIR PARTS section of this manual.)

**WARRANTY**

**FULL ONE YEAR WARRANTY ON CRAFTSMAN GAS CHIPPER-VACUUM**

For one year from the date of purchase, when this Craftsman chipper-vacuum is maintained, lubricated, and tuned up according to the operating and maintenance instructions in the operator's manual, Sears will repair, free of charge, any defect in material or workmanship.

This warranty excludes the chipper blades, flails, air cleaners, spark plugs, catcher bags and tires, which are expendable parts and become worn during normal use.

If this chipper-shredder is used for commercial or rental purposes, this warranty applies for only 30 days from the date of purchase.

WARRANTY SERVICE IS AVAILABLE BY CONTACTING THE NEAREST SEARS SERVICE CENTER IN THE UNITED STATES. THIS WARRANTY APPLIES ONLY WHILE THIS PRODUCT IS IN USE IN THE UNITED STATES.

This warranty gives you specific legal rights, and you may also have other rights which vary from state to state.

SEARS ROEBUCK AND CO., DEPT. 817WA, HOFFMAN ESTATES, IL 60179



# TABLE OF CONTENTS

SAFETY RULES.....2, 3	OPERATION .....8-11
PRODUCT SPECIFICATIONS.....4	CUSTOMER RESPONSIBILITIES .....12, 13
MAINTENANCE AGREEMENT.....4	STORAGE .....14
CUSTOMER RESPONSIBILITIES .....4, 12, 13	SERVICE AND ADJUSTMENT .....14-17
WARRANTY .....4	TROUBLE SHOOTING.....18
INDEX.....5	PARTS ORDERING/SERVICE.....18
ACCESSORIES.....5	REPAIR PARTS—CHIPPER-VACUUM .....19-25
ASSEMBLY .....6-8	REPAIR PARTS—ENGINE .....26-29

## INDEX

<p style="text-align: center;"><b>A</b></p> <p>Accessories .....5</p> <p>Adjustments:</p> <p style="padding-left: 20px;">Carburetor.....17</p> <p style="padding-left: 20px;">Clutch Cable .....7</p> <p style="padding-left: 20px;">Engine Speed .....17</p> <p style="padding-left: 20px;">Shift Rod .....16</p> <p>Assembly Instructions.....6-8</p> <p style="text-align: center;"><b>C</b></p> <p>Catcher Bag .....7, 8</p> <p>Controls .....9</p> <p>Customer Responsibilities .....4, 12, 13</p> <p style="text-align: center;"><b>E</b></p> <p>Engine:</p> <p style="padding-left: 20px;">Lubrication .....12</p> <p style="padding-left: 20px;">Maintenance .....12, 13</p> <p style="padding-left: 20px;">Starting .....11</p> <p style="padding-left: 20px;">Stopping.....9, 11</p> <p style="padding-left: 20px;">Storage .....14</p> <p style="text-align: center;"><b>F</b></p> <p>Fuel .....10</p> <p style="text-align: center;"><b>L</b></p> <p>Lubrication .....12</p>	<p style="text-align: center;"><b>M</b></p> <p>Maintenance:</p> <p style="padding-left: 20px;">Agreement .....4</p> <p style="padding-left: 20px;">Schedule .....12</p> <p style="padding-left: 20px;">Engine.....12, 13</p> <p style="padding-left: 20px;">Chipper-Vacuum .....12</p> <p style="text-align: center;"><b>O</b></p> <p>Oil .....10</p> <p>Operating Tips .....9, 10</p> <p style="text-align: center;"><b>R</b></p> <p>Repair/Replacement Parts .....19-29</p> <p>Responsibilities, Customer .....4, 12, 13</p> <p style="text-align: center;"><b>S</b></p> <p>Safety Rules .....2, 3</p> <p>Sharpening .....15</p> <p>Spark Plug .....13</p> <p>Specifications.....4</p> <p>Storage .....14</p> <p style="text-align: center;"><b>T</b></p> <p>Table of Contents .....5</p> <p>Trouble Shooting .....18</p> <p style="text-align: center;"><b>U</b></p> <p>Unclogging.....14, 15</p> <p>Unpacking.....6</p> <p style="text-align: center;"><b>W</b></p> <p>Warranty .....4</p>
--	--

## ACCESSORIES

These accessories were available when the chipper-vacuum was purchased. They are also available at most Sears retail outlets, catalog and service centers. Most Sears stores can order repair parts for you, when you provide the model number of your chipper-vacuum.

### ENGINE

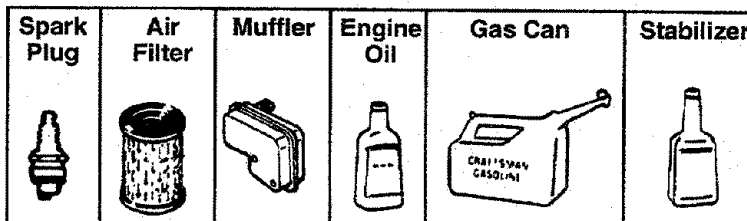

### CHIPPER-VACUUM

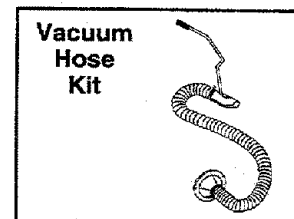

# ASSEMBLY INSTRUCTIONS

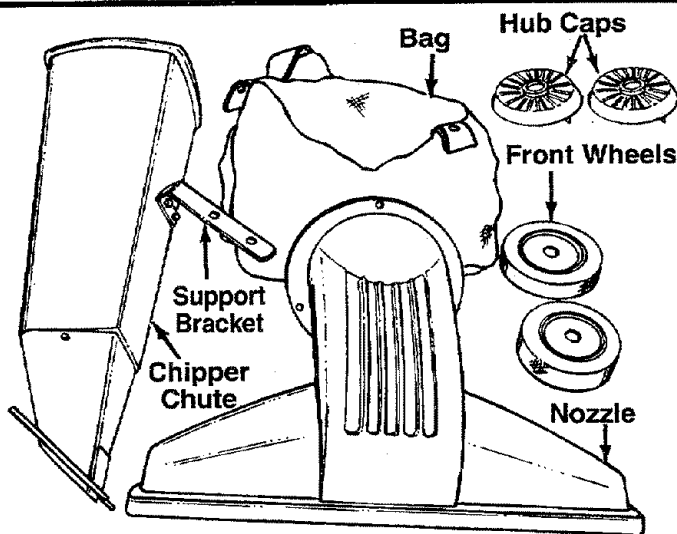

FIGURE 1.

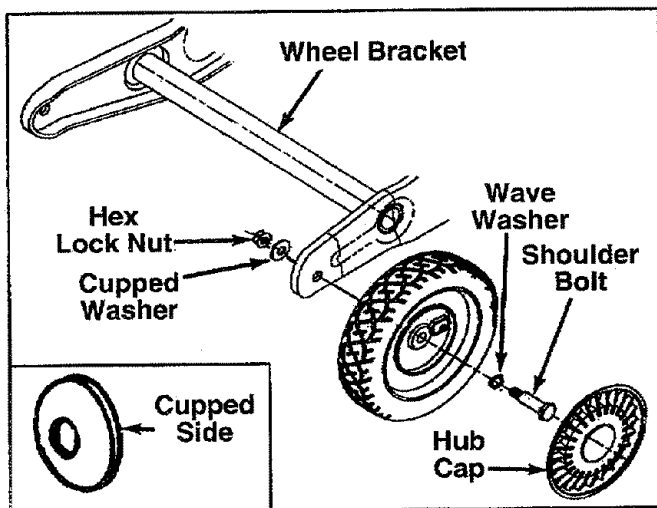

FIGURE 2.

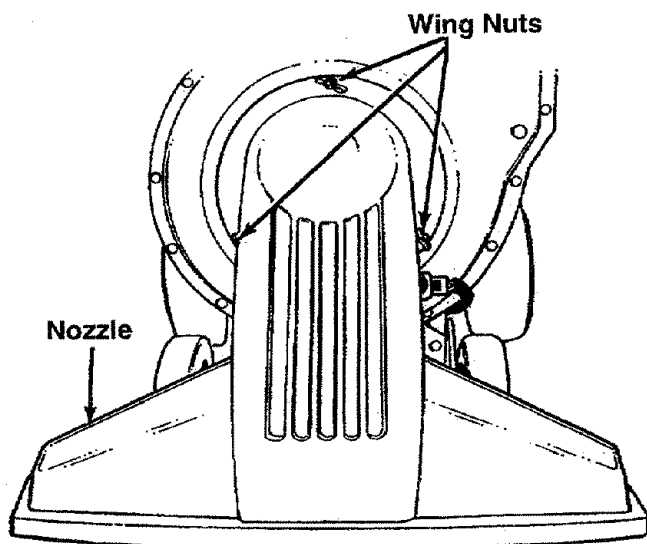

FIGURE 3.

**IMPORTANT:** This unit is shipped WITHOUT GASOLINE or OIL in the engine. After assembly, see operation section of this manual for proper fuel and engine oil recommendations.

**NOTE:** To determine right and left hand sides of your chipper-vacuum, stand behind and face the unit (Refer to figure 7).

Your chipper-vacuum has been completely assembled at the factory except for the front wheels, hub caps, nozzle, chipper chute, support bracket and bag. A pair of safety glasses and bottle of oil are also included in the carton.

## TO REMOVE CHIPPER-VACUUM FROM CARTON

Cut the corner of the carton. Remove all packing inserts and loose parts. Push down on handle to lift front of chipper-vacuum, and roll chipper-vacuum out of the carton. Make certain all parts and literature have been removed before the carton is discarded.

## TOOLS REQUIRED FOR ASSEMBLY

- (1) 3/4" Open End Wrench
- (2) 1/2" or Adjustable Wrenches
- (1) 9/16" Wrench
- (1) Funnel

## LOOSE PARTS IN CARTON (See Figure 1)

- |                     |                     |
|---------------------|---------------------|
| (2) Front Wheels    | (1) Bag             |
| (2) Hub Cap†        | (1) Shift Knob†     |
| (1) Nozzle          | (1) Tamper Plug†    |
| (1) Chipper Chute   | (1) Safety Glasses† |
| (1) Support Bracket | (1) Bottle of Oil   |
- †Not Shown

## HOW TO SET-UP YOUR CHIPPER-VACUUM

### ATTACHING THE FRONT WHEELS

- Tilt unit backward so that it rests on the handle - (place a piece of the carton under handle to avoid scratches). Remove the cardboard packing material around the wheel brackets.
- Remove the hex lock nuts and shoulder bolts from the front of the wheel brackets. See figure 2.
- Place wave washer on shoulder bolt. Insert shoulder bolt through wheel, with the head of the shoulder bolt through the flat side of the wheel.
- Assemble wheel to outside of wheel bracket. Secure with cupped washer (cupped side of washer goes against the bracket) and hex lock nut. Tighten.
- Align the four tabs on the hub caps with the four holes in the wheel. Press in each tab until it locks in place. The hub cap edges must be flush with the wheel rim when installed properly.

### ATTACHING THE NOZZLE (See figure 3)

- Remove the three plastic wing nuts from the front of the chipper-vacuum. Place the nozzle in position over the three weld studs. Secure with the wing nuts just removed.

**NOTE:** The metal tab in the nozzle must depress the safety switch on the front of the chipper-vacuum or the engine will not start.

- Set unit in upright position.

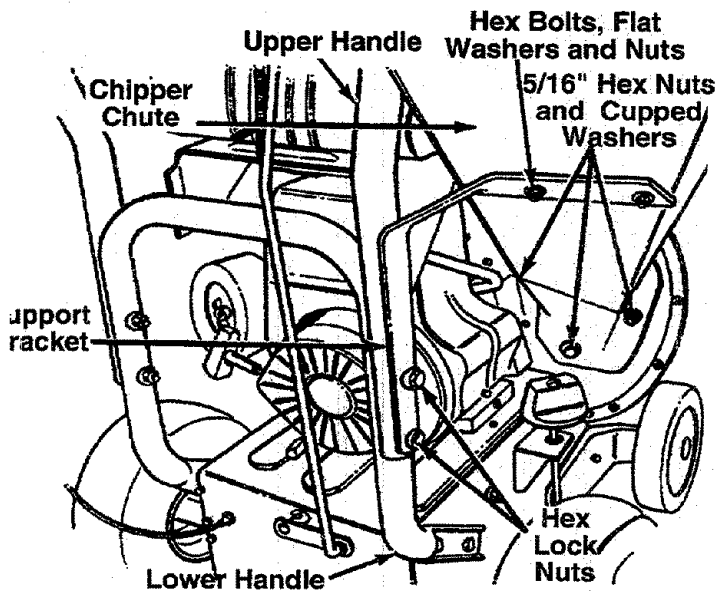

FIGURE 4.

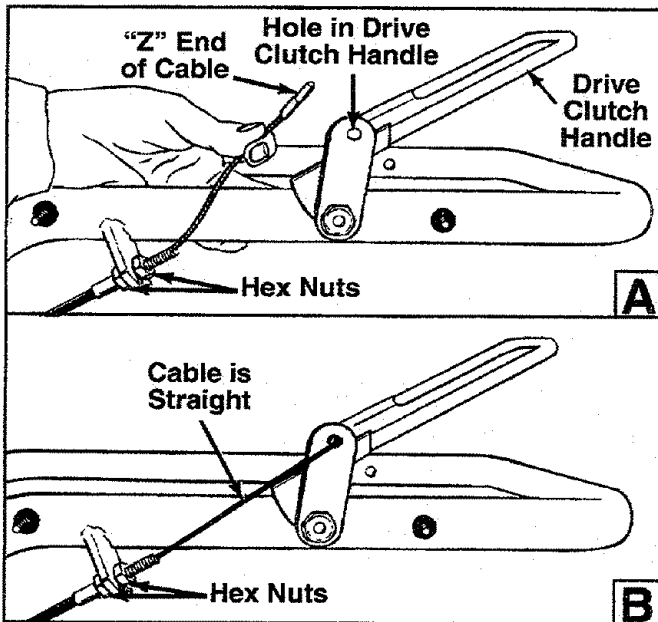

FIGURE 5.

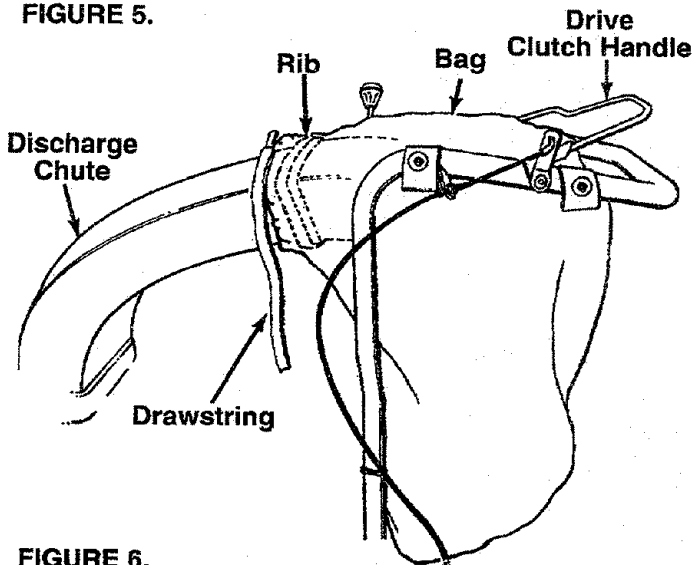

FIGURE 6.

### ATTACHING THE CHIPPER CHUTE AND SUPPORT BRACKET (See figure 4)

- Remove the two hex lock nuts from the hex bolts which secure the right side of the upper handle to the lower handle. Leave bolts and washers in place.
- Remove three cupped washers and 5/16" hex nuts from the weld studs beside the opening on the right side of the chipper-vacuum.
- Place the chipper chute in position over the weld studs (slot goes at the bottom). Secure with cupped washers and hex nuts just removed.

**NOTE:** Only tighten the three nuts one or two threads for ease of further assembly.

**NOTE:** Cupped side of the washer goes against the chipper chute. See figure 2 to identify cupped side of washer.

- Remove the two hex bolts, flat washers and nuts which are attached to the support bracket.
- Attach the support bracket to the bottom of the chipper chute loosely using the hardware removed previously. HEADS OF THE HEX BOLTS AND WASHERS GO TO THE INSIDE OF THE CHIPPER CHUTE.
- Place the support bracket over the two bolts in the handle. Pushing UP on the chipper chute will aid the alignment of the holes in the support bracket with the bolts in the handle.
- Tighten all hardware securely on the chipper chute, support bracket and handle.

### ATTACHING THE CLUTCH CABLE

The clutch cable has been assembled at the factory. Loosen the hex nuts at the cable bracket. Hook the "Z" end of the cable into the drive clutch handle from the outside to the inside as shown in figure 5A. Pliers will aid in assembly.

### CLUTCH CABLE ADJUSTMENT

Adjust the hex nuts at the cable bracket so there is no slack in the cable, but the cable is **NOT** tight. Do not overtighten the cable. See figure 5B.

To check the clutch adjustment, proceed as follows.

- Push the chipper-vacuum backward and forward with the drive clutch handle released. It should move freely. If it does not, loosen both hex nuts at the cable bracket. See figure 5B. Turn bottom nut counter-clockwise to loosen the cable.
- Engage the drive clutch handle (hold against upper handle), and try to push chipper-vacuum backward and forward. The wheels should lock up. If the wheels do not lock up, loosen both hex nuts at the cable bracket. Turn bottom nut clockwise to tighten the cable.
- Recheck adjustment. Tighten both hex nuts when correct adjustment is reached.

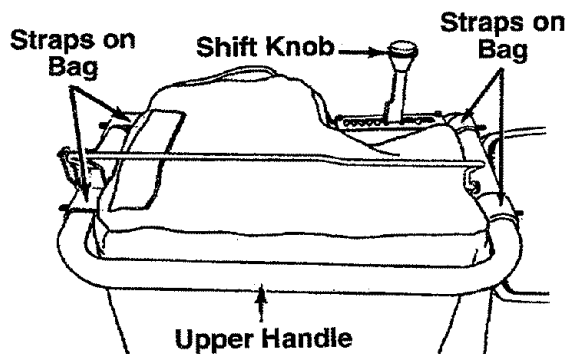

FIGURE 7.

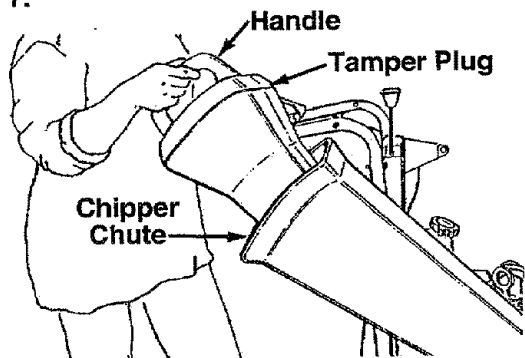

FIGURE 8.

### ATTACHING THE BAG

- Place bag inside of handle assembly. Slip the opening on the bag over the discharge chute, making certain it is over the rib on the discharge chute. See figure 6.
  - Place the four straps on the top of the bag over upper handle, hooking them on studs. See figure 7.
- NOTE:** Be sure the bag goes under the drive clutch handle.
- Squeeze the clamp on the drawstring, and pull the drawstring tight. Release the clamp.

### INSTALLING THE SHIFT KNOB

Remove the cardboard protecting the threads. Thread the shift knob onto the end of the shift lever.

### TAMPER PLUG

The handle on the tamper plug must be in the vertical position as shown in figure 8. To determine which side of the tamper plug is up, match the angle of the tamper plug to the angle of the chipper chute.

Insert the tamper plug into the chipper chute. Tamper plug should remain in the chipper chute whenever the chipper chute is not in use.

## OPERATION

### KNOW YOUR CHIPPER-VACUUM

READ THIS OWNER'S MANUAL AND SAFETY RULES BEFORE OPERATING YOUR CHIPPER-VACUUM. Compare the illustrations with your chipper-vacuum to familiarize yourself with the location of various controls and adjustments. Save this manual for future reference.

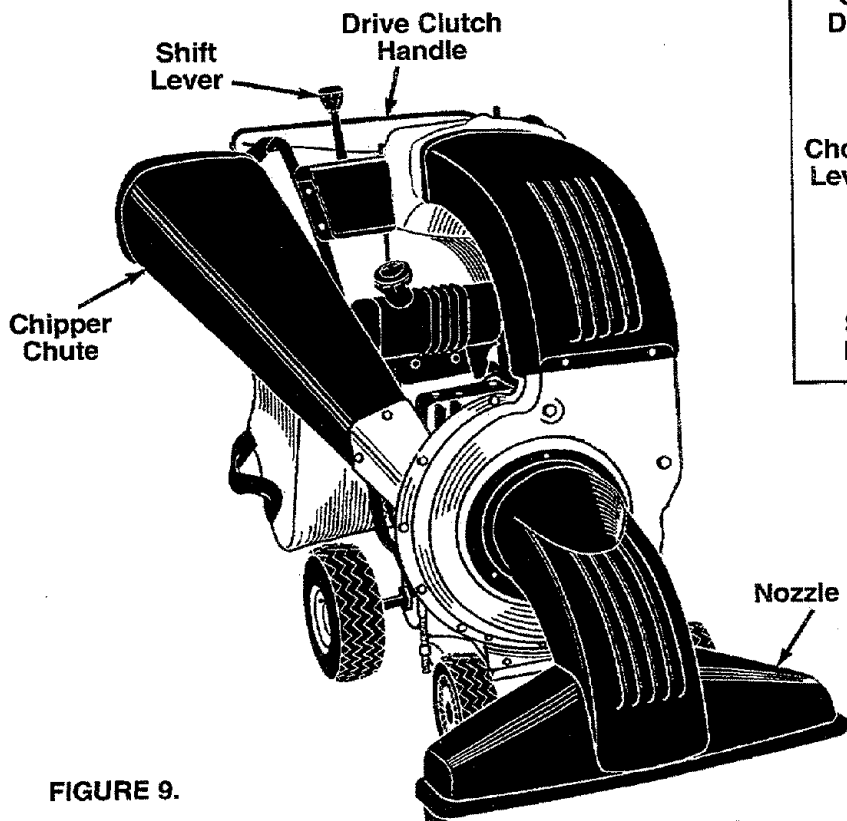
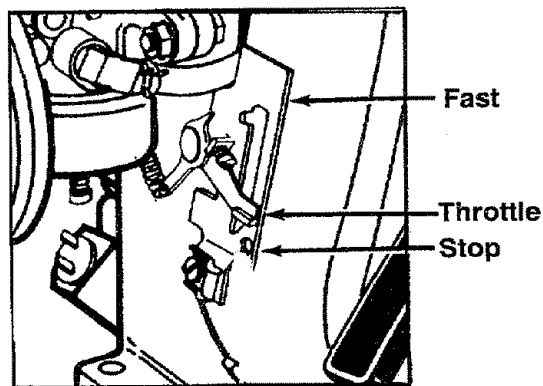
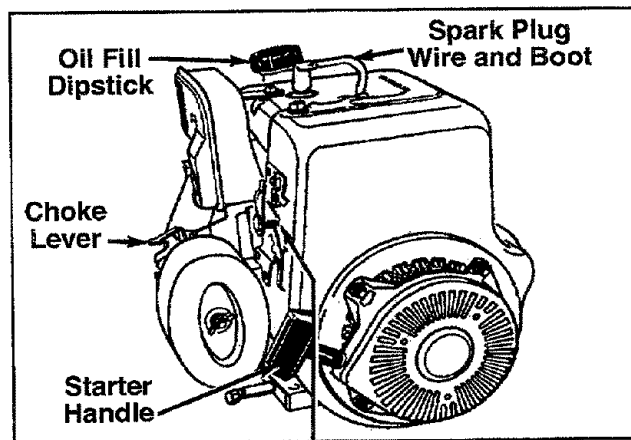

FIGURE 9.



## MEETS ANSI SAFETY STANDARDS

Sears chipper-vacuums conform to the safety standards of the American National Standards Institute.

### OPERATING CONTROLS (See figure 9)

**SHIFT LEVER**—The shift lever determines ground speed. It may be placed in one of eight positions.

**Forward**—one of six speeds. Position number one (1) is the slowest. Position number six (6) is the fastest.

**Reverse**—two reverse (R) speeds. "R" (all the way to the right) is the faster of the two.

**DRIVE CLUTCH HANDLE (BAIL)**—Squeezing the drive clutch handle against the upper handle engages

the wheel drive. Release the drive clutch handle to stop the forward drive.

**CHOKE LEVER**—Used to enrich the fuel mixture in the carburetor when starting a cold engine.

**STARTER HANDLE**—Used to manually start the engine.

**THROTTLE CONTROL**—Controls engine speed and stops the engine.

BEFORE USING YOUR CHIPPER-VACUUM, AGAIN REFER TO THE "SAFETY RULES" AS SHOWN ON PAGE 2 OF THIS MANUAL. ALWAYS BE CAREFUL.



The operation of any chipper-vacuum can result in foreign objects being thrown into the eyes, which can result in severe eye damage. Always wear the safety glasses provided with the chipper-vacuum or eye shields before chipping, or while performing any adjustments or repairs. We recommend Wide Vision Safety Mask for over spectacles or standard glasses available at Sears Retail or Catalog Stores.

### TO STOP ENGINE

- Move throttle control lever to STOP position. See figure 9.
- Disconnect spark plug wire and move away from spark plug to prevent accidental starting while equipment is unattended.

### HOW TO USE YOUR CHIPPER-VACUUM



**WARNING: YOUR CHIPPER-VACUUM IS EQUIPPED WITH A SAFETY SWITCH ON THE FRONT OF THE HOUSING. NOZZLE OR HOSE ATTACHMENT MUST BE IN PLACE ON THE CHIPPER-VACUUM BEFORE THE ENGINE CAN BE STARTED.**

### TO ENGAGE DRIVE

**IMPORTANT: Always release the drive clutch handle before moving the shift lever.**

- With the engine running near top speed, move shift lever into one of the six FORWARD positions or two REVERSE positions. Select a speed appropriate for the conditions that exist. Use the slower speeds until you are familiar with the operation of the chipper-vacuum.
- To engage the wheel drive, hold the drive clutch handle against the chipper-vacuum handle. Releasing the drive clutch handle stops the wheels from driving. Release the drive clutch handle to slow down when negotiating an obstacle, making a turn or stopping. Engage slowly to prevent front wheels from lifting up.

### NOZZLE HEIGHT ADJUSTMENT

The height adjustment knob is located on the right hand side of the chipper-vacuum. See figure 10. Turn the knob clockwise to raise the nozzle. Turn the knob counterclockwise to lower. (Be careful not to turn knob too far—rod could come out of ferrule.)

The best height for the nozzle will vary according to the conditions. Adjust the height of the nozzle to find the setting which gives the best performance for the operating conditions. In general, raise the nozzle to vacuum a thick layer of leaves; lower the nozzle for smooth surfaces.

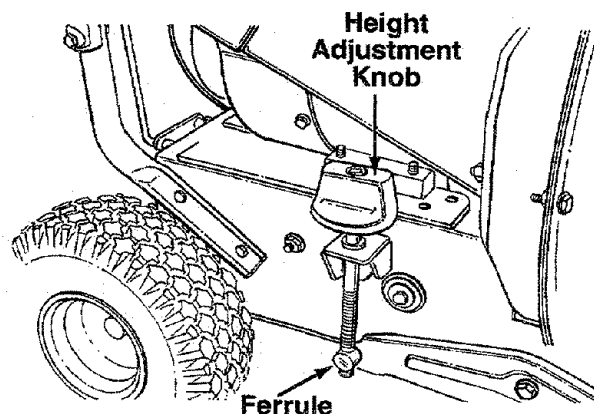

FIGURE 10.

### USING THE CHIPPER CHUTE

Do not attempt to chip any material other than vegetation found in a normal yard (i.e., branches, leaves, twigs, etc.). Material such as stalks or heavy branches up to 3" in diameter may be fed into the chipper chute. See figure 11.



**WARNING: MATERIAL UP TO A MAXIMUM OF 3" IN DIAMETER MAY BE FED INTO THE CHIPPER CHUTE. DO NOT ATTEMPT TO CHIP ANY MATERIAL LARGER THAN 3" IN DIAMETER. PERSONAL INJURY OR DAMAGE TO THE MACHINE COULD RESULT.**

If necessary, use the tamper plug provided to push material into the chipper chute. See figure 8. **NEVER PLACE HANDS INSIDE CHIPPER CHUTE.** Place tamper plug inside chipper chute when not in use to deaden the sound.

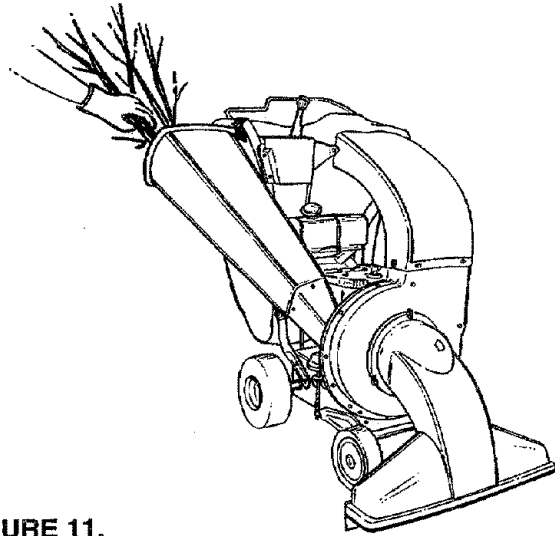

**FIGURE 11.**

**IMPORTANT:** There is a flail screen located inside the housing in the discharge area. If the flail screen becomes clogged, remove and clean as instructed in the Service and Adjustment section on page 14.

For best performance, it is important to keep the chipper blades sharp. If the composition of the material being discharged changes (becomes stringy, etc.) or if the rate at which the material is discharged slows down considerably, it is likely that the chipper blades are dull and need to be sharpened or replaced. Refer to Service and Adjustments sections.

**TO EMPTY BAG**

Open the large zipper on the bag to empty the bag. See figure 12. **Be certain the zipper is closed when operating the unit.**

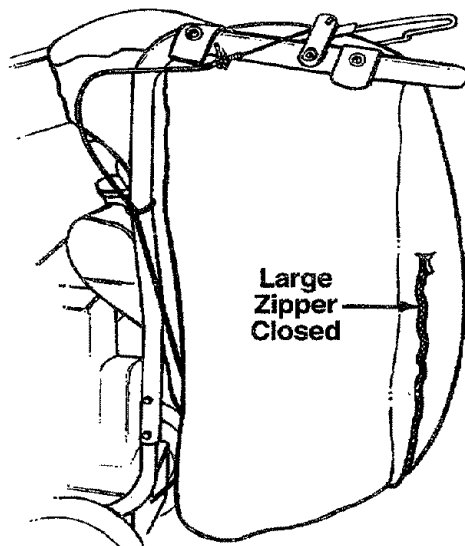

**FIGURE 12.**

**GAS AND OIL FILL-UP**

**OIL**

Only use high quality detergent oil rated with API service classification SF, SG or SH. Select the oil's viscosity grade according to your expected operating temperature.



**NOTE:** Although multi-viscosity oils (5W30, 10W30, etc.) improve starting in cold weather, these multi-viscosity oils will result in increased oil consumption when used above 32°F. Check your oil level more frequently to avoid possible engine damage from running low on oil.

- Use engine oil provided. Remove oil fill dipstick. See figure 13. With chipper-vacuum level, use a funnel to fill engine with oil to FULL mark on dipstick. Capacity is approximately 26 ounces. **Be careful not to overfill.** Oil bottle provided contains 27 oz. of oil. Tilt chipper-vacuum toward the left (from behind the hopper), then re-level. Check oil level. Refill to FULL mark on dipstick if necessary. Replace dipstick and tighten.

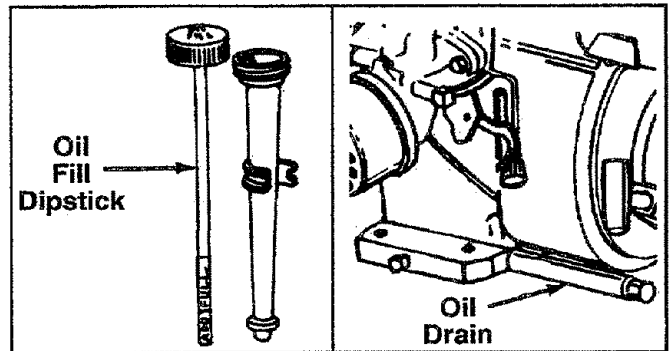

**FIGURE 13.**

**GAS**

- Remove fuel cap and fill fuel tank with approximately 1 gallon of clean, fresh, lead-free grade automotive gasoline. **DO NOT** use Ethyl or high octane gasoline. Be certain container is clean and free from rust or foreign particles. Never use gasoline that may be stale from long periods of storage in the container. Replace fuel cap.



**WARNING: DO NOT FILL CLOSER THAN 1/2 INCH OF TOP OF FUEL TANK TO PREVENT SPILLS AND TO ALLOW FOR FUEL EXPANSION. IF GASOLINE IS ACCIDENTLY SPILLED, MOVE CHIPPER-VACUUM AWAY FROM AREA OF SPILL. AVOID CREATING ANY SOURCE OF IGNITION UNTIL GASOLINE VAPORS HAVE DISAPPEARED.**



Check the fuel level periodically to avoid running out of gasoline while operating the chipper-vacuum. If the unit runs out of gas as it is chipping, it may be necessary to unclog the unit before it can be restarted. Refer to "Removing the Flail Screen" in SERVICE AND ADJUSTMENT section.

**WARNING: EXPERIENCE INDICATES THAT ALCOHOL BLENDED FUELS (CALLED GASOHOL OR USING ETHANOL OR METHANOL) CAN ATTRACT MOISTURE WHICH LEADS TO SEPARATION AND FORMATION OF ACIDS DURING STORAGE. ACIDIC GAS CAN DAMAGE THE FUEL SYSTEM OF AN ENGINE WHILE IN STORAGE. TO AVOID ENGINE PROBLEMS, THE FUEL SYSTEM SHOULD BE EMPTIED OR TREATED WITH FUEL STABILIZER BEFORE STORAGE FOR 30 DAYS OR LONGER. USE FRESH FUEL NEXT SEASON. SEE "STORAGE" SECTION FOR ADDITIONAL INFORMATION.**

**NEVER USE ENGINE OR CARBURETOR CLEANER PRODUCTS IN THE FUEL TANK OR PERMANENT DAMAGE MAY OCCUR.**

## TO START ENGINE

**IMPORTANT: IF UNIT SHOWS ANY SIGN OF MOTION WITH THE CLUTCH HANDLE DISENGAGED, SHUT ENGINE OFF IMMEDIATELY. READJUST AS INSTRUCTED IN THE "FINAL ADJUSTMENTS" SECTION OF THE ASSEMBLY INSTRUCTIONS.**



**WARNING: BE SURE NO ONE OTHER THAN THE OPERATOR IS STANDING NEAR THE CHIPPER-VACUUM WHILE STARTING OR OPERATING. DO NOT OPERATE THIS CHIPPER-VACUUM UNLESS THE NOZZLE, DISCHARGE CHUTE AND BAG HAVE BEEN PROPERLY INSTALLED.**

- Attach spark plug wire and rubber boot to spark plug if necessary. See figure 9.
- Place the throttle control lever in FAST position.
- Move choke lever to CHOKE position (See figure 14).
- Place one foot on the left rear wheel to prevent the unit from skidding while starting.
- Grasp starter handle and pull rope out slowly until engine reaches start of compression cycle (rope will pull slightly harder at this point). Let the rope rewind slowly.

**NOTE:** A noise will be heard when finding the start of the compression cycle. This noise is caused by the flails and fingers which are part of the shredding mechanism falling into place, and should be expected. In addition, the flails and fingers will be noisy after the engine is started, until the impeller reaches full speed.

- Pull rope with a rapid, continuous, full arm stroke. Keep a firm grip on start handle. Let rope rewind slowly. Do not let starter handle snap back against starter.
- Repeat preceding two instructions until engine fires. When engine starts, move choke lever on engine halfway between CHOKE and OFF.

**NOTE:** If engine does not fire after three attempts, move choke lever halfway between CHOKE and OFF position and try again.

- Move throttle control to IDLE position for a few minutes warm-up. Move choke lever to OFF position as engine warms up.

**NOTE:** In order to idle smoothly, a new engine may require 3 to 5 minutes running above slow idle speed. Idle speed has been adjusted to be correct after this break-in period.

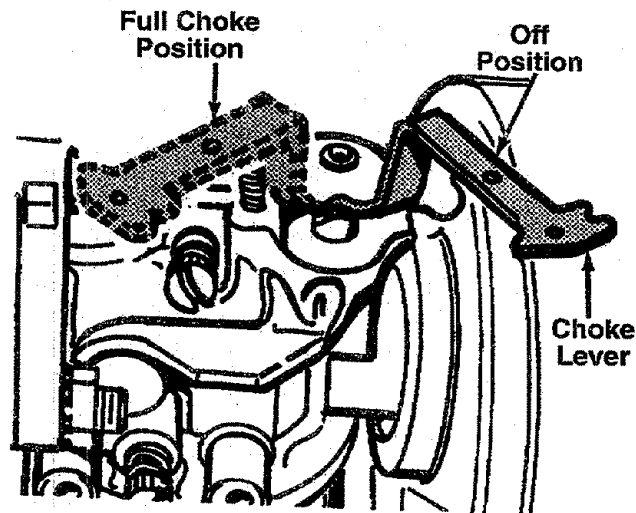

FIGURE 14.

## TO STOP ENGINE

- Move throttle control lever to STOP position.
- Disconnect spark plug wire and move away from spark plug to prevent accidental starting while equipment is unattended.

# CUSTOMER RESPONSIBILITIES

<b>MAINTENANCE SCHEDULE</b> FILL IN DATES AS YOU COMPLETE REGULAR SERVICE		BEFORE EACH USE	AFTER EACH USE	FIRST FIVE HOURS	EVERY 25 HOURS	EVERY 50 HOURS	BEFORE STORAGE	SERVICE DATES						
<b>PRODUCT</b>	Oil Pivot Points					√								
	Clean Chipper-Vacuum		√			√								
<b>ENGINE</b>	Check Engine Oil	√												
	Change Engine Oil			√	√									
	Service Air Cleaner				√									
	Clean Engine Cylinder				√	√								
	Spark Plug				√	√								
	Muffler					√								

√ CHECK

## GENERAL RECOMMENDATIONS



**WARNING: ALWAYS STOP THE ENGINE AND DISCONNECT THE SPARK PLUG WIRE BEFORE PERFORMING ANY MAINTENANCE OR ADJUSTMENTS.**

- Periodically check all fasteners and be sure they are tight.
- Follow the Maintenance Schedule above.

## CHIPPER-VACUUM

### LUBRICATION

Lubricate the pivot points on the height adjustment mechanism once a season using a light oil.

### CLEANING

- Clean the chipper-vacuum thoroughly after each use.
- Wash the bag periodically with water. Allow to dry thoroughly in the shade. Do not use heat.

## ENGINE

### ENGINE OIL

Only use high quality detergent oil rated with API service classification SF, SG or SH. Select the oil's viscosity grade according to your expected operating temperature.

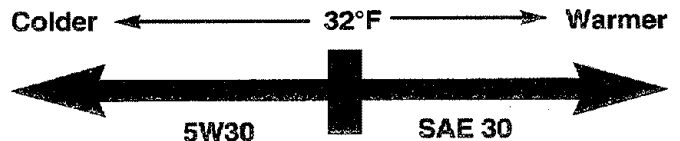

**NOTE:** Although multi-viscosity oils (SE30, 10W30, etc.) improve starting in cold weather, these multi-viscosity oils will result in increased oil consumption when used above 32°F. Check your oil level more frequently to avoid possible engine damage from running low on oil.

Your four-cycle engine will normally consume some oil—therefore, check engine oil level regularly approximately every five hours of operation and before each usage. Stop engine and wait several minutes before checking oil level. With engine level, the oil must be to FULL mark on dipstick (refer to figure 10). Change engine oil after the first five hours of operation, and every twenty-five hours thereafter.

### To Drain Oil:

- Drain oil while engine is warm.
  - a. Remove oil drain cap. Refer to figure 10. Catch oil in a suitable container.
  - b. When engine is drained of all oil, replace drain cap securely.
- Refill with fresh oil. Refer to GAS AND OIL FILL-UP section.
- Replace dipstick.



## AIR CLEANER

The air cleaner prevents damaging dirt, dust, etc., from entering the carburetor and being forced into the engine and is important to engine life and performance.

**Never run your engine without air cleaner completely assembled.**

### To Service Air Cleaner:

Service pre-cleaner after every 25 hours of use, or at least once a season. Replace filter every 100 hours of use, or at least once a season. Service pre-cleaner and filter more often under dusty conditions.

- Remove wing nut and cover. See figure 15.
- Slide pre-cleaner off filter. Clean the inside of base and cover thoroughly.
- Clean pre-cleaner as follows.  
Wash in water and detergent solution, and squeeze (do not twist) until all dirt is removed.  
Rinse thoroughly in clear water.  
Wrap in a clean cloth and squeeze (do not twist) until completely dry, or allow to air dry.
- If necessary, replace filter (do not attempt to clean).
- Install new filter on base. Slide pre-cleaner over filter.
- Install cover and wing nut. Tighten wing nut securely.

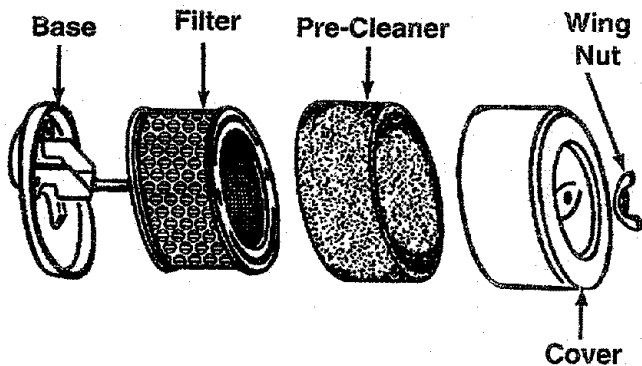

FIGURE 15.

## CLEAN ENGINE

Clean engine periodically. Remove dirt and debris with a cloth or brush. Cleaning with a forceful spray of water is not recommended as water could contaminate the fuel system.

Yearly or every 25 hours, whichever occurs first, remove the air intake screen and blower housing, and clean the areas shown in figure 16 to avoid over-speeding, overheating and engine damage. Clean more often if necessary.



**WARNING: PERIODICALLY CLEAN MUFFLER AREA TO REMOVE ALL GRASS, DIRT AND COMBUSTIBLE DEBRIS.**

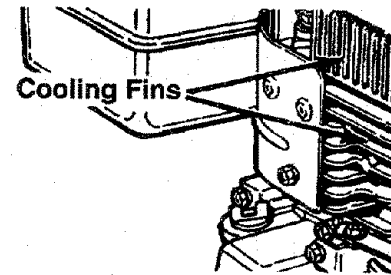

FIGURE 16.

## SPARK PLUG

The spark plug should be cleaned and the gap reset to .030" at least once a season or every 50 hours of operation. See figure 17. Spark plug replacement is recommended at the start of each season. Refer to engine parts list for correct spark plug type.

**NOTE:** Do not sandblast spark plug. Spark plug should be cleaned by scraping or wire brushing and washing with a commercial solvent.

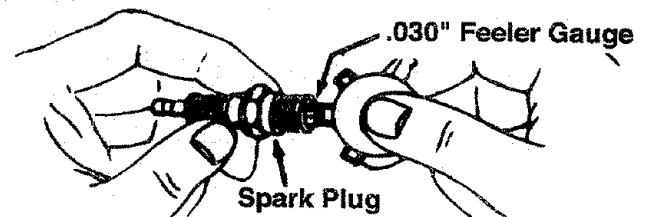

FIGURE 17.

## MUFFLER

Do not operate the chipper-vacuum without a muffler or tamper with the exhaust system. Damaged mufflers or spark arresters could create a fire hazard. Inspect periodically, and replace if necessary. If your engine is equipped with a spark arrester screen assembly, remove every 50 hours for cleaning and inspection. Replace if damaged.

---

## STORAGE

---

Prepare your chipper-vacuum for storage at the end of the season or if the unit will not be used for 30 days or more.



**WARNING: NEVER STORE MACHINE WITH FUEL IN THE FUEL TANK INSIDE OF BUILDING WHERE FUMES MAY REACH AN OPEN FLAME OR SPARK, OR WHERE IGNITION SOURCES ARE PRESENT SUCH AS HOT WATER AND SPACE HEATERS, FURNACES, CLOTHES DRYERS, STOVES, ELECTRIC MOTORS, ETC.**

**NOTE:** A yearly check-up by your local Sears Service Center is a good way to make certain your chipper-vacuum will provide maximum performance for the next season.

### CHIPPER-VACUUM

- Clean the chipper-vacuum thoroughly.
- Wipe unit with an oiled rag to prevent rust (use a light oil or silicone).

### ENGINE

**IMPORTANT:** IT IS IMPORTANT TO PREVENT GUM DEPOSITS FROM FORMING IN ESSENTIAL FUEL SYSTEM PARTS SUCH AS CARBURETOR, FUEL FILTER, FUEL HOSE, OR TANK DURING STORAGE. ALSO, EXPERIENCE INDICATES THAT ALCOHOL BLENDED FUELS (CALLED GASOHOL OR USING ETHANOL OR METHANOL) CAN ATTRACT MOISTURE WHICH LEADS TO SEPARATION AND FORMATION OF ACIDS DURING STORAGE. ACIDIC GAS CAN DAMAGE THE FUEL SYSTEM OF AN ENGINE WHILE IN STORAGE.

- Drain the fuel tank.
- Start the engine and let it run until the fuel lines and carburetor are empty.
- Never use engine or carburetor cleaner products in the fuel tank or permanent damage may occur.
- Use fresh fuel next season.

**NOTE:** Fuel stabilizer is an acceptable alternative in minimizing the formation of fuel gum deposits during storage. Add stabilizer to gasoline in fuel tank or storage container. Always follow the mix ratio found on stabilizer container. Run engine at least 10 minutes after adding stabilizer to allow the stabilizer to reach the carburetor. Do not drain the gas tank and carburetor if using fuel stabilizer.

- Drain all the oil from the crankcase (this should be done after the engine has been operated and is still warm) and refill the crankcase with fresh oil.
- If you have drained the fuel tank, protect the inside of the engine as follows. Remove spark plug, pour approximately 1/2 ounce (approximately one table-spoon) of engine oil into cylinder and crank slowly to distribute oil. Replace spark plug.

### OTHER

- Do not store gasoline from one season to another.
- Replace your gasoline can if your can starts to rust. Rust and/or dirt in your gasoline will cause problems.
- Store unit in a clean, dry area. Do not store next to corrosive materials, such as fertilizer.

**NOTE:** If storing in an unventilated or metal storage shed, be certain to rustproof the equipment by coating with a light oil or silicone.

---

## SERVICE & ADJUSTMENT

---



**WARNING: ALWAYS STOP ENGINE AND DISCONNECT SPARK PLUG WIRE AND MOVE IT AWAY FROM SPARK PLUG BEFORE PERFORMING ANY ADJUSTMENTS OR REPAIRS.**

### REMOVING THE FLAIL SCREEN

If the discharge area becomes clogged, remove the flail screen and clean area as follows.

- Stop the engine. Make certain the chipper-vacuum has come to a complete stop. Disconnect the spark plug wire before unclogging the discharge chute.

- Remove the vacuum bag from the unit.
- Remove the four self-tapping screws from the bottom of the discharge chute, and the hex bolt, flat washer and hex nut from the top. (Be careful not to drop the hardware into the chute.) Remove the discharge chute assembly. See figure 18.

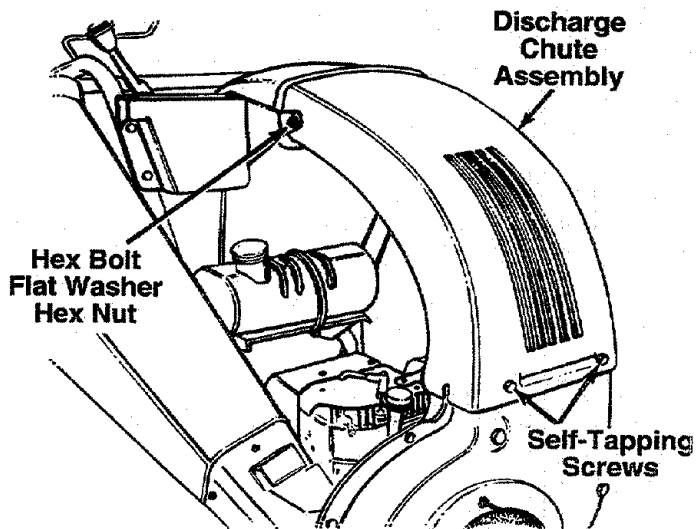

FIGURE 18.

- Remove the two hex bolts and hex nuts which extend through the housing. Lift the flail screen from inside the housing. See figure 19.

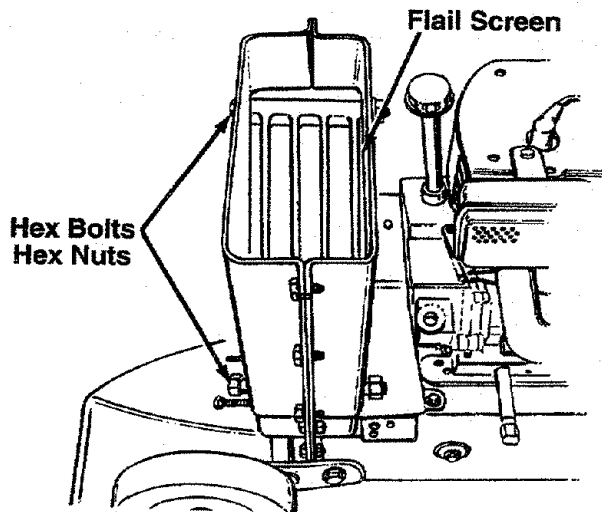

FIGURE 19.

- Clean the screen by scraping or washing with water. Reinstall the screen.

**NOTE:** Be certain to reassemble the flail screen with the curved side down as shown in figure 19.

### SHARPENING OR REPLACING CHIPPER BLADES

- Disconnect the spark plug wire and move away from the spark plug.
- Remove the flail screen as instructed in the previous section.
- Remove the plastic belt cover on the front of the engine by removing the two self-tapping screws. See figure 20.

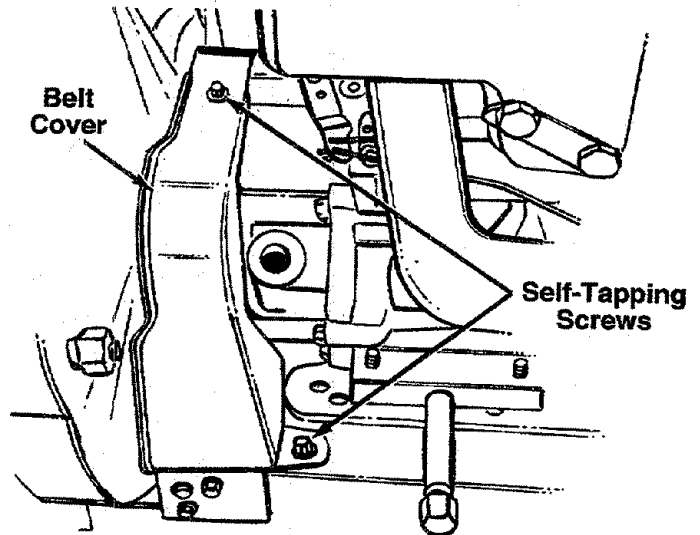

FIGURE 20.

- Remove the access plate by removing two hex lock nuts. See figure 21.

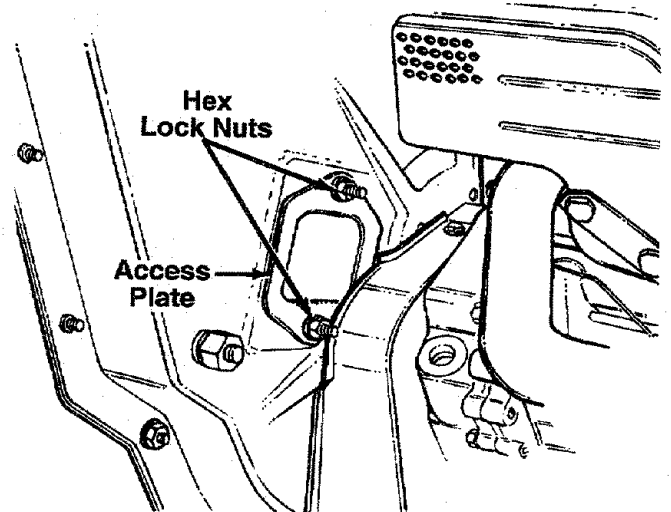

FIGURE 21.

- Locate one of the chipper blades in the access plate opening by rotating the impeller assembly by hand. Remove the blade using a 3/16" allen wrench on the outside of the blade and 1/2" wrench on the impeller assembly, inside the housing. Torque hardware to 250-350 inch pounds.
- Remove the other blade in the same manner. Replace or sharpen blades. If sharpening, make certain to remove an equal amount from each blade. Reassemble in reverse order.

**NOTE:** Make certain blades are reassembled with the sharp edge facing upward, as viewed from the access plate opening.

## CHANGING THE FRICTION WHEEL RUBBER

The rubber on the friction wheel is subject to wear and should be checked after 50 hours of operation, and periodically thereafter. Replace friction wheel rubber if any signs of wear or cracking are found.

- Drain the gasoline and oil from the chipper-vacuum.
- Tip the unit backward so it rests on the handles.
- Remove the frame cover by removing eight self-tapping screws from underneath the chipper-vacuum. See figure 22.

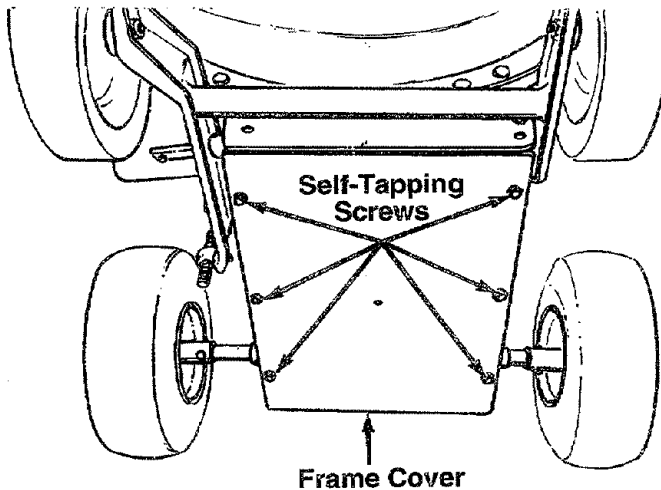

FIGURE 22.

- Remove the gear shaft from the unit by removing the hex bolts, lock washers and flat washers from each side of the frame. See figure 23. Hold the friction wheel assembly, and slide the gear shaft out of the unit toward the right side.

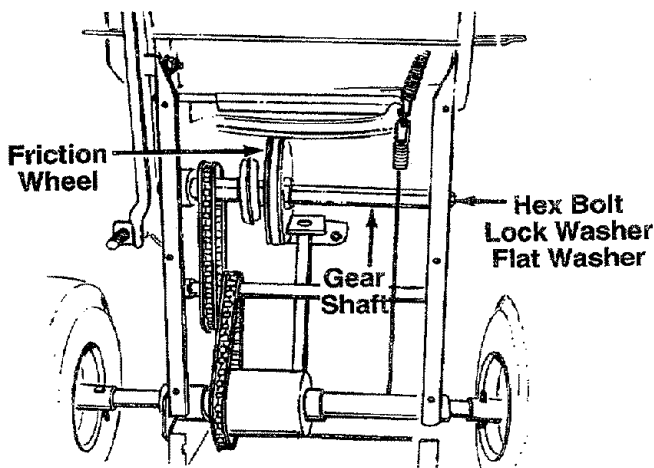

FIGURE 23.

- Remove the six screws from the friction wheel assembly (three from each side). Remove the friction wheel rubber from between the friction wheel plate.
- Reassemble new friction wheel rubber to the friction wheel assembly, tightening the six screws in rotation and with equal force.
- Slide the friction wheel assembly up onto the shift mechanism, then slide the gear shaft back into the unit. Reassemble in reverse order.
- Readjust the clutch cable. Refer to adjustment section.

## CLUTCH CABLE ADJUSTMENT

To adjust the clutch cable, refer to the "Clutch Cable Adjustment" section of Assembly Instructions.

## SHIFT ROD ADJUSTMENT

If the shift rod needs adjustment to obtain forward or reverse correctly, proceed as follows. See figure 24.

- Remove the bag from the unit.
- Remove the hairpin clip and flat washer from the upper end of the shift rod. Pull the ferrule out of the hole in the shift lever. (Make certain wave washer remains in place on the ferrule.)
- Place the shift lever in 6th position (all the way to the left).
- Push down on the shift rod. Thread the ferrule up or down the shift rod until the ferrule lines up with the upper hole in the shift lever.
- Secure ferrule to shift lever with flat washer and hairpin clip.
- If you cannot obtain proper adjustment, remove the gasoline and oil from the engine. Tip the unit backward so it rests on the handle. Remove the bottom frame cover. Check to see that all of the rubber on the friction wheel on the aluminum plate when the shift lever is in the 6th position. Adjust the ferrule on the shift rod as needed. Reassemble.

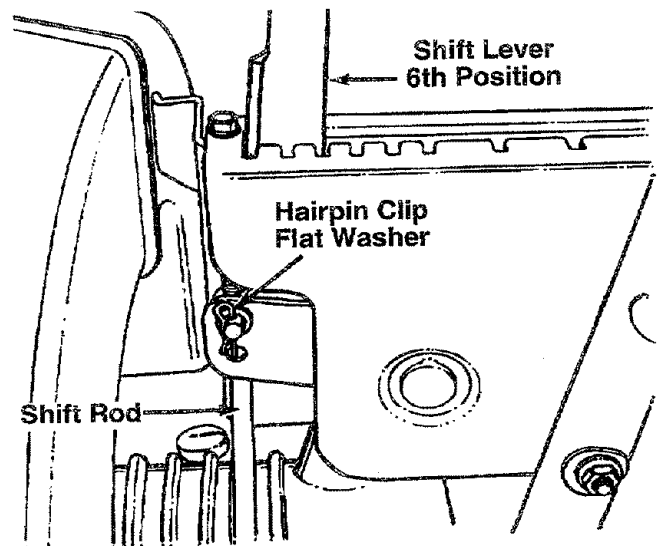

FIGURE 24.

## BELT REMOVAL AND REPLACEMENT



**WARNING:** Disconnect the spark plug wire and move away from the spark plug.

- Remove the plastic belt cover on the front of the engine by removing two self-tapping screws. Refer to figure 19.
- Drain the gasoline and oil from the chipper-vacuum.
- Tip the unit backward so that it rests on the handles.
- Remove the frame cover by removing eight self-tapping screws from underneath the chipper-vacuum. Refer to figure 14.
- Remove the idler pulley bracket as follows. See figure 25.
  - Take the tension off the belt by pivoting the idler pulley toward you, and line up the holes in the idler bracket assembly. Insert a nail or similar object through the holes to hold the idler pulley in this position.
  - Remove three self-tapping screws, and lift off the idler bracket assembly.

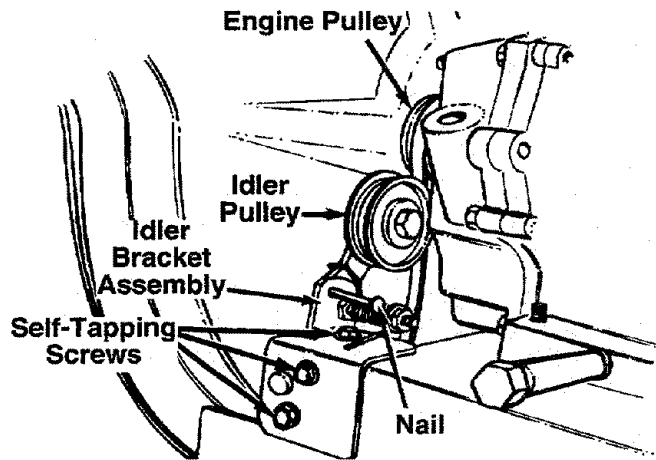

FIGURE 25.

- Remove the hex bolt and lock washer from the engine pulley. See figure 25. Slip the engine pulley off the engine shaft, and remove the belt from the pulley.
- Loosen the nut on the stop bolt until there is clearance between the support bracket and the friction wheel disc. See figure 26.
- Slip the belt between the friction wheel and friction wheel disc. Remove and replace belt. Reassemble following instruction in reverse order.

**NOTE:** The support bracket must rest on the stop bolt after the new belt has been assembled.

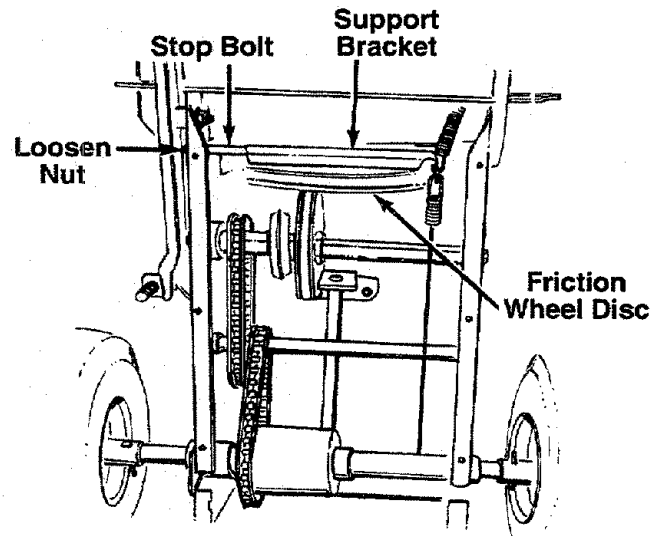

FIGURE 26.

## CARBURETOR ADJUSTMENT



**WARNING:** IF ANY ADJUSTMENTS ARE MADE TO THE ENGINE WHILE THE ENGINE IS RUNNING (E.G. CARBURETOR), KEEP CLEAR OF ALL MOVING PARTS. BE CAREFUL OF HEATED SURFACES AND MUFFLER.

The carburetor has been pre-set at the factory and should not require adjustment. However, if your engine does not operate properly due to suspected carburetor problems, take your chipper-vacuum to your nearest SEARS Service Center.

## ENGINE SPEED

Your engine speed has been factory set. Do not attempt to increase engine speed or it may result in personal injury. If you believe the engine is running too fast or too slow, take your chipper-vacuum to the nearest SEARS Service Center for repair and adjustment.

# TROUBLE SHOOTING

PROBLEM	POSSIBLE CAUSE(S)	CORRECTIVE ACTION
Engine fails to start	<ul style="list-style-type: none"> <li>● Fuel tank empty, or stale fuel.</li> <li>● Spark plug wire disconnected.</li> <li>● Faulty spark plug.</li> <li>● Nozzle safety switch not depressed.</li> </ul>	<ul style="list-style-type: none"> <li>● Fill tank with clean, fresh fuel.</li> <li>● Connect wire to spark plug.</li> <li>● Clean, adjust gap or replace.</li> <li>● Adjust metal tab so it depresses the safety switch.</li> </ul>
Loss of power; operation erratic	<ul style="list-style-type: none"> <li>● Spark plug wire loose.</li> <li>● Unit running on CHOKE.</li> <li>● Blocked fuel line or stale fuel.</li>   <li>● Water or dirt in fuel system.</li>   <li>● Carburetor out of adjustment.</li>   <li>● Dirty air cleaner.</li> </ul>	<ul style="list-style-type: none"> <li>● Connect and tighten spark plug wire.</li> <li>● Move choke lever to OFF position.</li> <li>● Clean fuel line; fill tank with clean fresh gasoline.</li> <li>● Disconnect fuel line at carburetor to drain fuel tank. Refill with fresh fuel.</li> <li>● Adjust carburetor or contact your SEARS Service Center.</li> <li>● Service air cleaner. See Customer Responsibilities section of this manual.</li> </ul>
Engine overheats	<ul style="list-style-type: none"> <li>● Carburetor not adjusted properly.</li> <li>● Engine oil level low.</li> </ul>	<ul style="list-style-type: none"> <li>● Contact your SEARS Service Center.</li>   <li>● Fill crankcase with proper oil.</li> </ul>
Too much vibration	<ul style="list-style-type: none"> <li>● Loose parts or damaged impeller.</li> </ul>	<ul style="list-style-type: none"> <li>● Stop engine immediately and disconnect spark plug wire. Tighten all bolts and nuts. Make all necessary repairs. If vibration continues, have unit serviced by a SEARS Service Center.</li> </ul>
Unit does not discharge	<ul style="list-style-type: none"> <li>● Discharge chute clogged.</li>   <li>● Foreign object lodged in impeller.</li>   <li>● Vacuum bag is full.</li> </ul>	<ul style="list-style-type: none"> <li>● Stop engine immediately and disconnect spark plug wire. Clean flail screen and inside of blower housing. See Service/Adjustments section of this manual.</li> <li>● Stop engine immediately and disconnect spark plug wire. Remove lodged object.</li> <li>● Empty bag.</li> </ul>
Rate of discharge slows considerably or composition of discharged material changes	<ul style="list-style-type: none"> <li>● Chipper blades dull.</li> </ul>	<ul style="list-style-type: none"> <li>● Sharpen or replace chipper blades.</li> </ul>

NOTE: For repairs beyond the minor adjustments listed above, please contact your nearest SEARS Service Center.

## HOW TO ORDER REPLACEMENT PARTS

Each chipper-vacuum has its own model number. Each engine has its own model number.

The model number for your chipper-vacuum will be found on a label attached to the frame.

The model number for the engine will be found on the blower housing of the engine.

All parts listed herein may be ordered through Sears, Roebuck and Co. Service Centers and most Retail Stores.

**WHEN ORDERING REPAIR PARTS, ALWAYS GIVE THE FOLLOWING INFORMATION:**

\*PRODUCT - "9 H.P. Chipper-Vacuum"

\*MODEL NUMBER - 247.799640

\*ENGINE MODEL NO. - 143.959003

\*PART NUMBER

\*PART DESCRIPTION

Your Sears merchandise has added value when you consider that Sears has service units nationwide staffed with Sears trained technicians...professional technicians specifically trained on Sears products, having the parts, tools and the equipment to insure that we meet our pledge to you..."we service what we sell."

**IF YOU NEED REPAIR SERVICE OR PARTS:**

**REPAIR SERVICE  
1-800-4-REPAIR  
(1-800-473-7247)**

**ORDERING PARTS  
1-800-FON-PART  
(1-800-366-7278)**



# SEARS CRAFTSMAN 9 H.P. CHIPPER-VACUUM MODEL NO. 247.799640

## Repair Parts

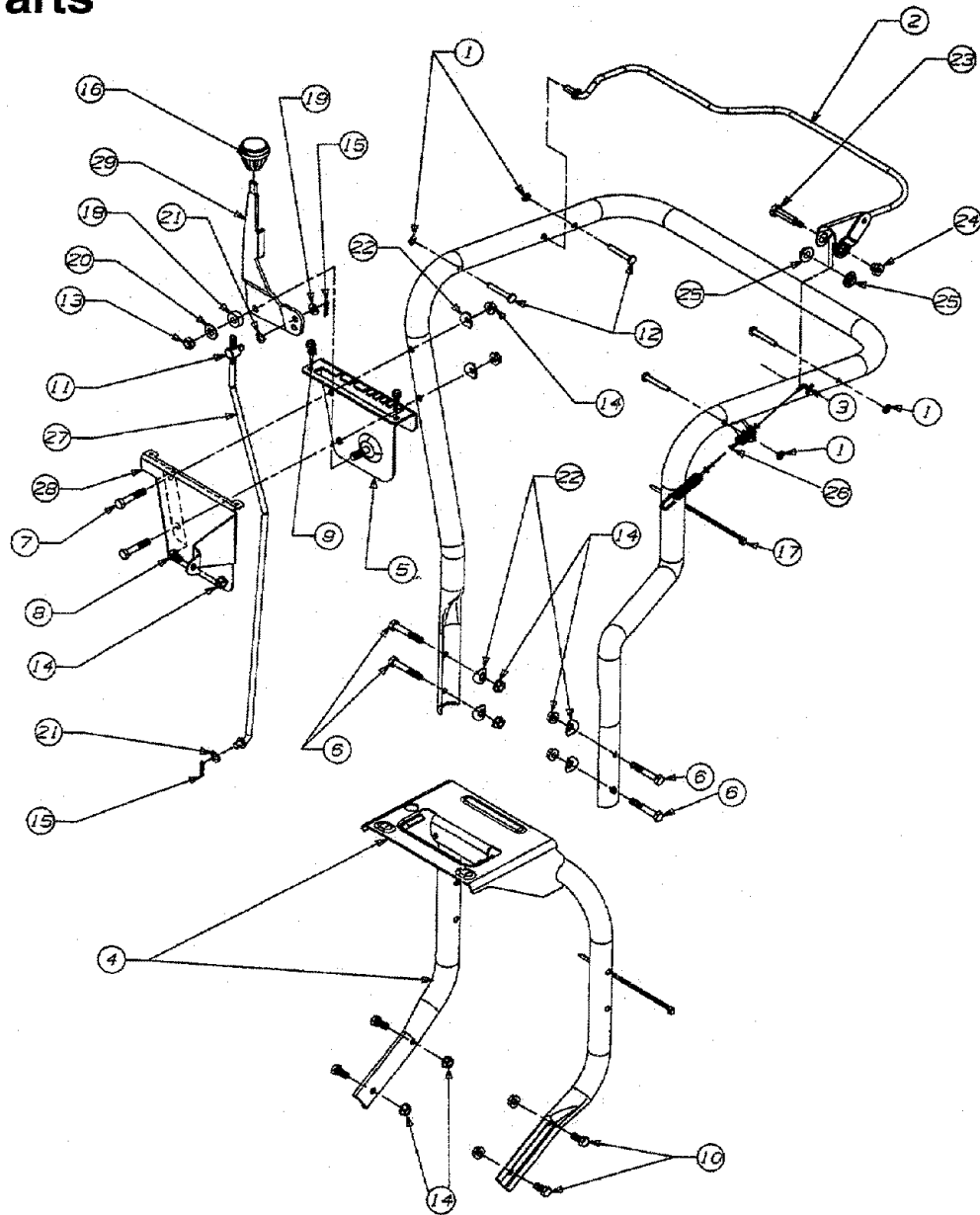

REF. NO.	PART NO.	DESCRIPTION	QTY.	REF. NO.	PART NO.	DESCRIPTION	QTY.
1	1539-019	PUSHNUT	4	16	720-0232	KNOB-SHIFT	1
2	647-0019	CONTROL ASSY	1	17	725-0157	CABLE TIE	2
3	649-0008	HANDLE ASSY-UPPER	1	18	735-0126	WASHER-RUBBER	1
4	649-0012	HANDLE ASSY-LOWER	1	19	736-0264	WASHER-FLAT	1
5	681-0076	BRACKET ASSY-SHIFT	1	20	736-0300	WASHER-FLAT	1
6	710-0116	SCREW-HEX	4	21	736-0413	WASHER-SPRING	2
7	710-0380	SCREW-HEX	2	22	736-0451	WASHER-SADDLE	6
8	710-0621	SCREW-HEX	1	23	738-0560	SCREW-SHOULDER	1
9	710-0896	SCREW-HEX	2	24	738-0561	NUT-SHOULDER	1
10	710-3008	SCREW-HEX	4	25	741-0402	BEARING-FLANGE PLASTIC	2
11	711-0677	FERRULE	1	26	746-0921	CABLE-CLUTCH	1
12	711-0737	PIN-STUD	4	27	747-0626	ROD-SHIFT	1
13	712-0116	NUT-HEX LOCK	1	28	781-0626	COVER-SHIFT	1
14	712-3004A	NUT-HEX LOCK	11	29	784-0297	HANDLE-SHIFT	1
15	714-0104	PIN-COTTER	2				



SEARS CRAFTSMAN 9 H.P. CHIPPER-VACUUM MODEL NO. 247.799640

Repair Parts

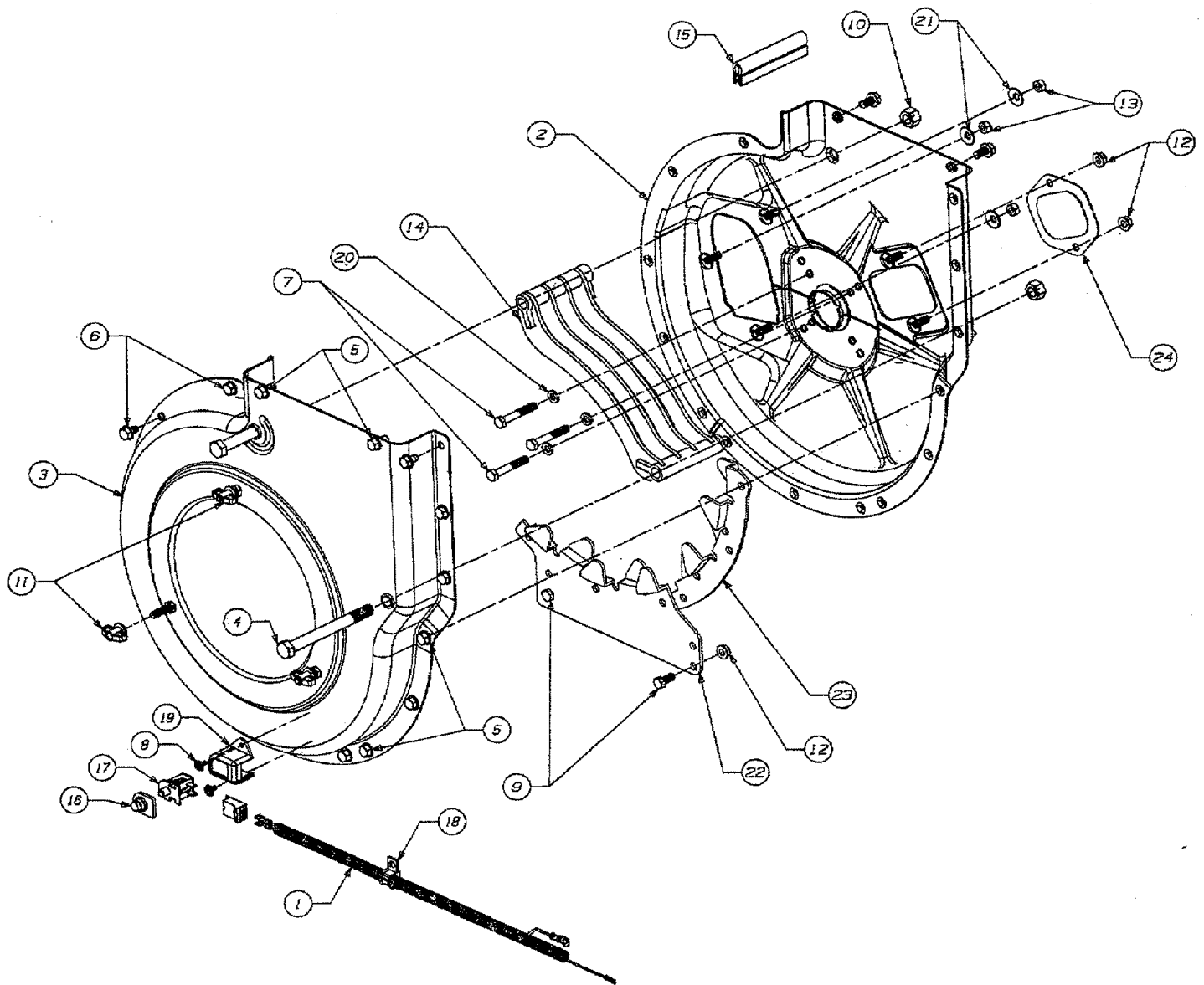

REF. NO.	PART NO.	DESCRIPTION	QTY.	REF. NO.	PART NO.	DESCRIPTION	QTY.
1	629-0241	HARNES—CHIPPER-VAC	1	13	712-3010	NUT-HEX (GR 5)	3
2	681-0059	HOUSING ASSY—INNER	1	14	719-0326	SCREEN	1
3	681-0060	HOUSING ASSY—OUTER	1	15	723-0438	SEAL-RUBBER	2
4	710-0382	SCREW-HEX	2	16	725-1700	COVER-SWITCH	1
5	710-0604	SCREW-HEX SELF TAP	10	17	725-3166	SNAP MOUNT SWITCH	1
6	710-0607	SCREW-HEX SELF TAP	8	18	726-0272	CLAMP	1
7	710-0772	SCREW-HEX	3	19	731-1613	COVER-SWITCH	1
8	712-1268	SCREW-HEX SELF TAP	2	20	736-0119	WASHER-LOCK	3
9	710-3008	SCREW-HEX	2	21	736-0242	WASHER-BELL	3
10	712-0384	NUT-HEX LOCK	2	22	781-0598	BLADE-FLAIL HOUSING	1
11	712-0421	KNOB	3	23	781-0599	BLADE-FLAIL HOUSING	1
12	712-3004A	NUT-HEX LOCK	4	24	781-0627	COVER-CHIPPER	1



# SEARS CRAFTSMAN 9 H.P. CHIPPER-VACUUM MODEL NO. 247.799640

## Repair Parts

REF. NO.	PART NO.	DESCRIPTION	QTY.
1	681-0078	IMPELLER ASSY COMP. (INCL. REF. NOS. 2 THRU 12)	1
2	710-1273	SCREW-HEX	1
3	736-0217	WASHER-LOCK	1
4	736-0247	WASHER-FLAT	1
5	681-0078	IMPELLER ASSY	1
6	711-0833A	PIN-CLEVIS	3
7	710-1054	SCREW-FLAT HEAD	4
8	712-0411	NUT-HEX LOCK	4
9	715-0249	PIN-ROLL SPRING	3
10	719-0329	BLADE-FLAIL	3
11	736-0119	WASHER-LOCK	4
12	742-0544	BLADE-CHIPPER	4

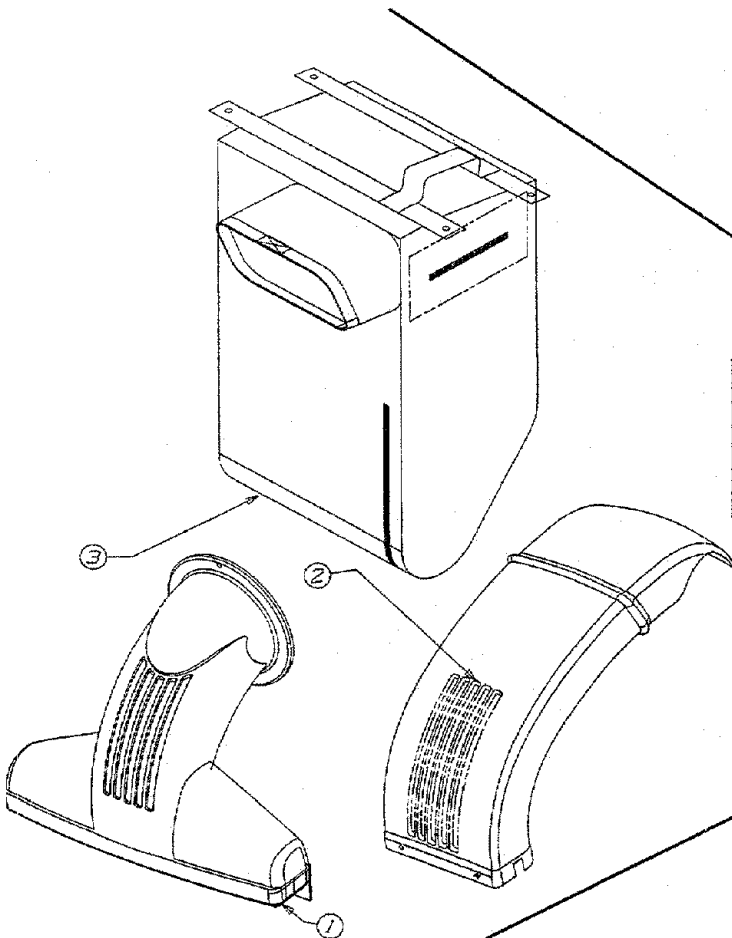
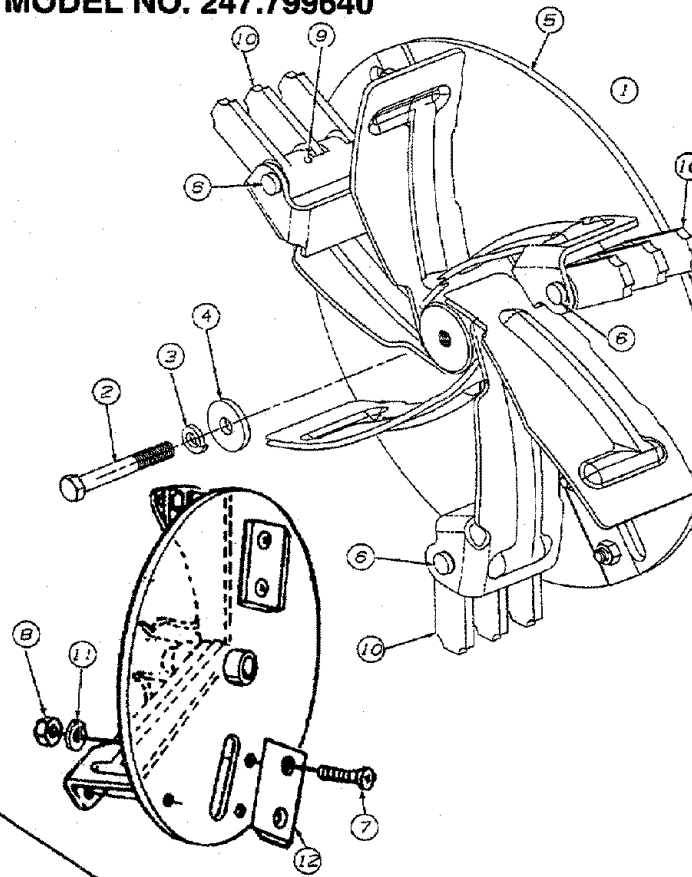

REF. NO.	PART NO.	DESCRIPTION	QTY.
1	631-0029	NOZZLE ASS'Y.-VACUUM	1
2	731-1616	CHUTE-DISCHARGE	1
3	764-0473	BAG-VACUUM	1

REF. NO.	PART NO.	DESCRIPTION	QTY.
1	681-0068	CHUTE ASSEMBLY	1
2	710-0258	SCREW HEX	5
3	712-3027	NUT-LOCK	5
4	731-1609	CHUTE -CHIPPER UPPER	1
5	781-0625	BRACKET SUPPORT	1
—	731-1617	TAMPER PLUG (Not Shown)	1

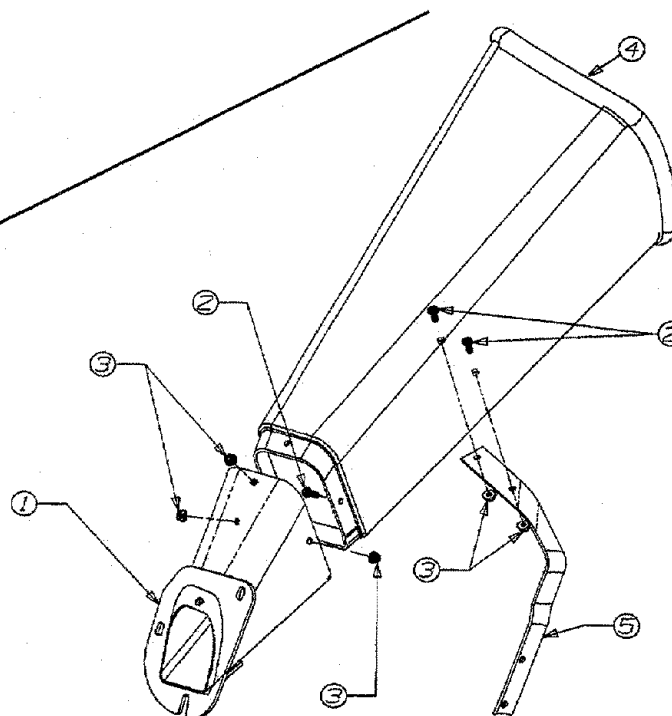

**SEARS CRAFTSMAN 9 H.P. CHIPPER-VACUUM MODEL NO. 247.799640**

**Repair Parts**

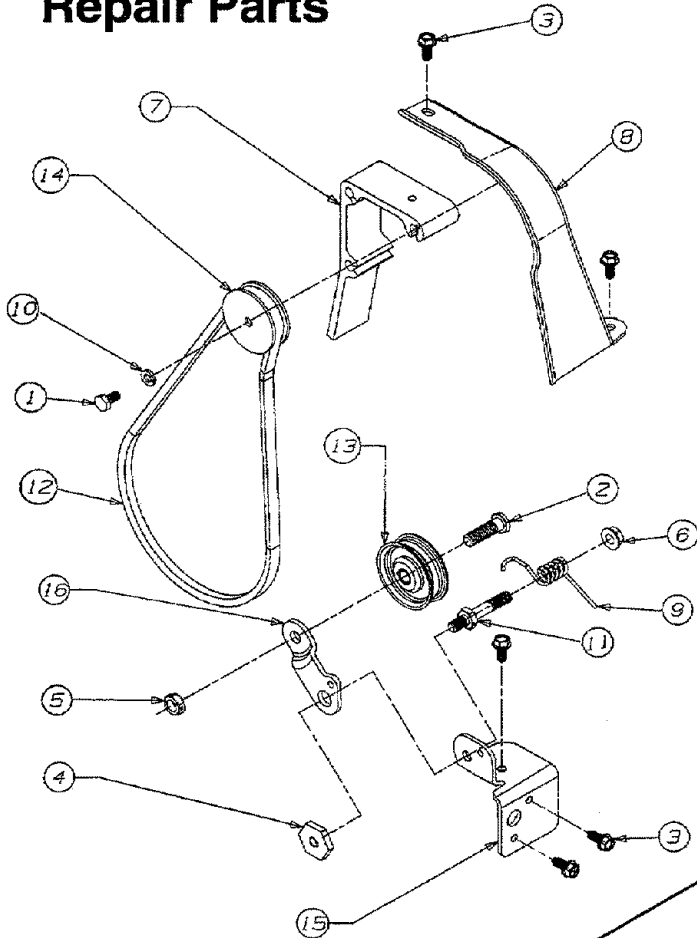

REF. NO.	PART NO.	DESCRIPTION	QTY.
1	710-0230	SCREW-HEX	1
2	710-0723	SCREW-HEX	1
3	710-0896	SCREW-HEX	5
4	711-0758	NUT-HEX SHOULDER	1
5	712-0266	NUT-HEX LOCK	1
6	712-3004A	NUT-HEX LOCK FLANGE	1
7	719-0330	ADAPTER-MOUNTING	1
8	731-1584	COVER-BELT	1
9	732-0745	SPRING-TORSION	1
10	736-0329	WASHER-LOCK	1
11	738-0908	BOLT-IDLER	1
12	754-0256	V-BELT	1
13	756-0313	IDLER-FLAT	1
14	756-0649	PULLEY	1
15	781-0611	BRACKET-IDLER PIVOT	1
16	781-0614	BRACKET-IDLER	1

REF. NO.	PART NO.	DESCRIPTION	QTY.
1	681-0070	BRKT ASSY—WHEEL PIVOT	1
2	710-0520	SCREW-HEX	1
3	710-0924	SCREW-MACHINE PAN HD	1
4	710-3008	SCREW-HEX	2
5	711-1041	FERRULE—ADJUSTABLE	1
6	712-3004A	NUT-HEX FLANGE	2
7	712-3005	NUT-HEX FLANGE LOCK	2
8	714-0115	PIN-COTTER	1
9	716-0104	RING-E	1
10	720-0236	KNOB-PLASTIC	1
11	736-0270	WASHER-BELL	1
12	736-0300	WASHER-FLAT	2
13	736-0369	WASHER-FLAT	2
14	738-0258	SCREW-SHOULDER	1
15	747-0631	ROD-ADJUSTABLE	1
16	750-0985	SPACER	1
17	781-0605	BRACKET-HEIGHT ADJ	1

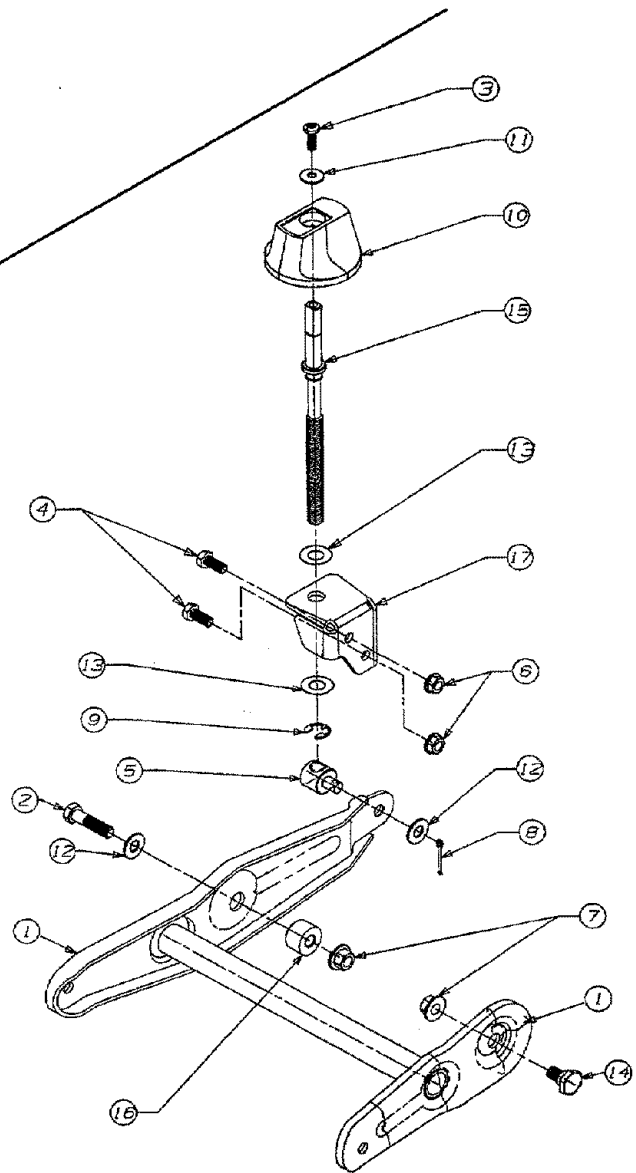

# SEARS CRAFTSMAN 9 H.P. CHIPPER-VACUUM MODEL NO. 247.799640

## Repair Parts

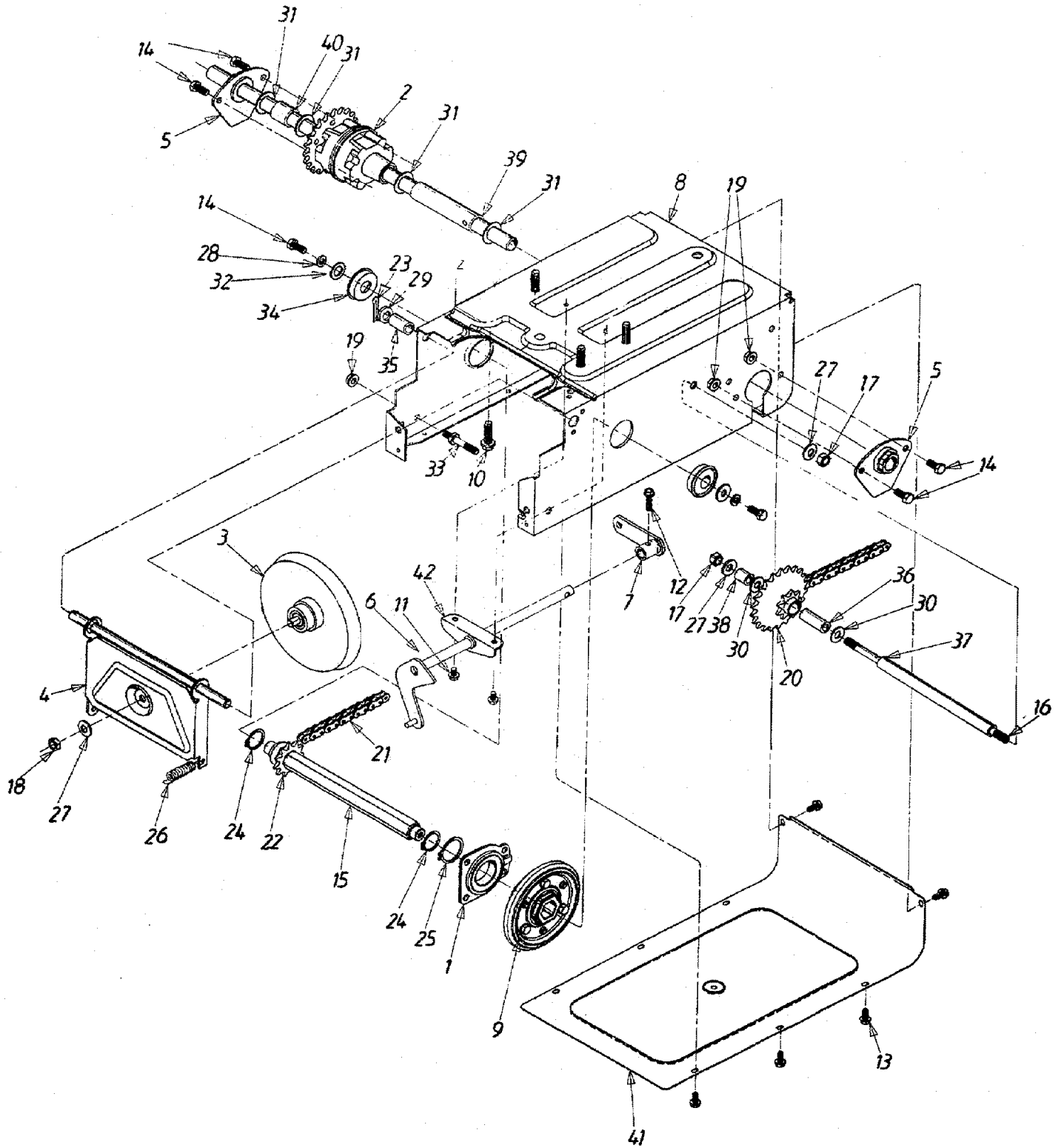

# SEARS CRAFTSMAN 9 H.P. CHIPPER-VACUUM MODEL NO. 247.799640

## Repair Parts

REF. NO.	PART NO.	DESCRIPTION	QTY.	REF. NO.	PART NO.	DESCRIPTION	QTY.
1	618-0063	BEARING ASSY-FRICTION WHEEL	1	20	713-0330	SPROCKET & HUB	1
2	618-0168	DIFFERENTIAL ASSY COMP.	1	21	713-0374	CHAIN	1
3	656-0009	DISC-FRICTION WHEEL ASSY COMP.	1	22	713-0415	SPROCKET 11T	1
	756-0564	DISC-FRICTION WHEEL	1	23	714-0474	PIN-COTTER	1
	738-0865	BOLT-SHOULDER		24	716-0102	RING-SNAP	2
	741-0600	BEARING-BALL		25	716-0185	RING-SNAP	1
4	681-0055	BRACKET ASSY-SUPPORT	1	26	732-0264	SPRING-EXTENSION	1
5	681-0058	BRACKET ASSY-AXLE	2	27	736-0105	WASHER-BELL	3
6	681-0069	SHAFT ASSY-SHIFT	1	28	736-0119	WASHER-LOCK	2
7	681-0072	ARM ASSY-SHIFT	1	29	736-0160	WASHER-FLAT	1
8	681-0073	FRAME ASSY	1	30	736-0267	WASHER-FLAT	2
9	684-0042	WHEEL ASSY-FRICTION	1	31	736-0287	WASHER-FLAT	4
10	710-0502A	SCREW-HEX SELF-TAP	4	32	736-3089	WASHER-FLAT	2
11	710-0653	SCREW-HEX WASHER	2	33	738-0908	BOLT-IDLER	1
12	710-0788	SCREW-HEX WASHER	1	34	741-0563	BEARING-BALL	2
13	710-0896	SCREW-HEX	8	35	748-0382	SPACER	1
14	710-3008	SCREW-HEX	6	36	750-0351	SLEEVE	1
15	711-1026	SHAFT-HEX	1	37	750-0978	SPACER	1
16	711-1028	SHAFT-JACK	1	38	750-0979	SPACER	1
17	712-0241	NUT-HEX	2	39	750-0980	SPACER	1
18	712-0711	NUT-HEX JAM	1	40	750-0981	SPACER	1
19	712-3004A	NUT-HEX FLANGE LOCK	5	41	781-0612	COVER-FRAME	1
				42	784-5590	BRACKET-SHIFT	1

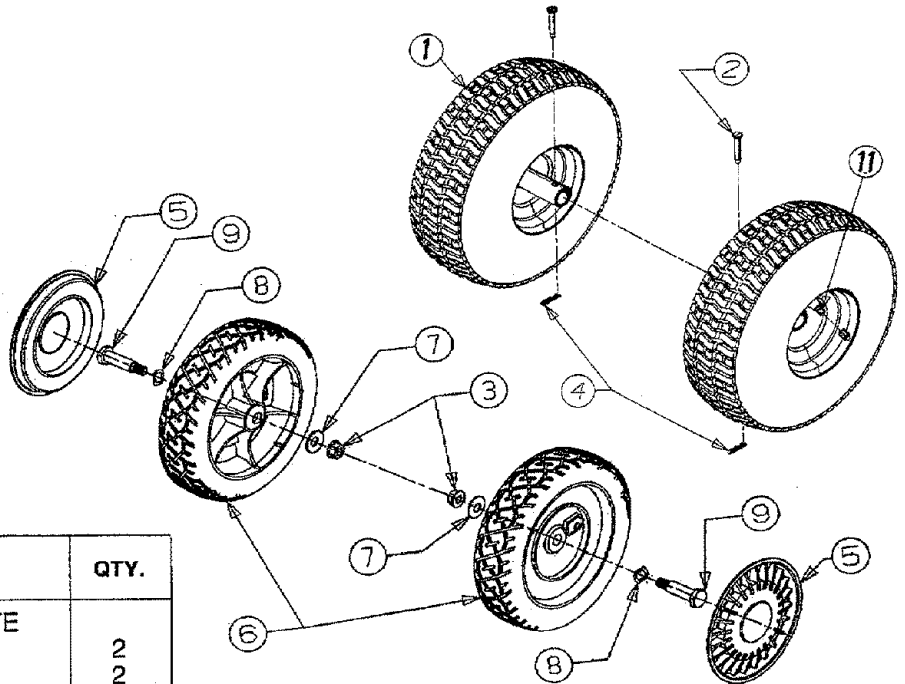

REF. NO.	PART NO.	DESCRIPTION	QTY.
1	634-0100	WHEEL ASSY COMPLETE 4" X 10"	2
	634-0101	RIM ASSY COMPLETE	2
	734-1598	TIRE PNEUMATIC 4" X 10"	2
2	711-1017	PIN-CLEVIS	2
3	712-3005	NUT-HEX FLANGE	2
4	714-0104	PIN-COTTER	2
5	731-0981A	HUB CAP	2
6	734-1793	WHEEL 2" X 8"	2
7	736-0105	WASHER-BELL	2
8	736-0232	WASHER-WAVE	2
9	738-0213	SCREW-SHOULDER	2
10	734-0255	VALVE STEM	2



# SEARS CRAFTSMAN 9 H.P. CHIPPER-VACUUM MODEL NO. 247.799640

## Repair Parts

REF. NO.	PART NO.	DESCRIPTION	QTY.
1	618-0168	DIFFERENTIAL ASSY COMPLETE	1
2	710-1206	SCREW-HEX	4
3	711-1035	SHAFT-CROSS	1
4	711-1037	AXLE-SHAFT 10.95" LONG	1
5	711-1038	AXLE-SHAFT 9.82" LONG	1
6	713-0445	SPROCKET 22 T	1
7	716-0232	RING-RETAINING (2 PER AXLE)	4
8	717-1358	GEAR-DIFFERENTIAL 14T	2
9	717-1437	GEAR-DIFFERENTIAL 10T	2
10	719-0333	HOUSING-DIFFERENTIAL RH	1
11	719-0334	HOUSING-DIFFERENTIAL LH	1
12	748-0383	BEARING-FLANGE	2
13	737-0300	GREASE	1 OZ
14	—	SEALANT-LOCTITE 5699	

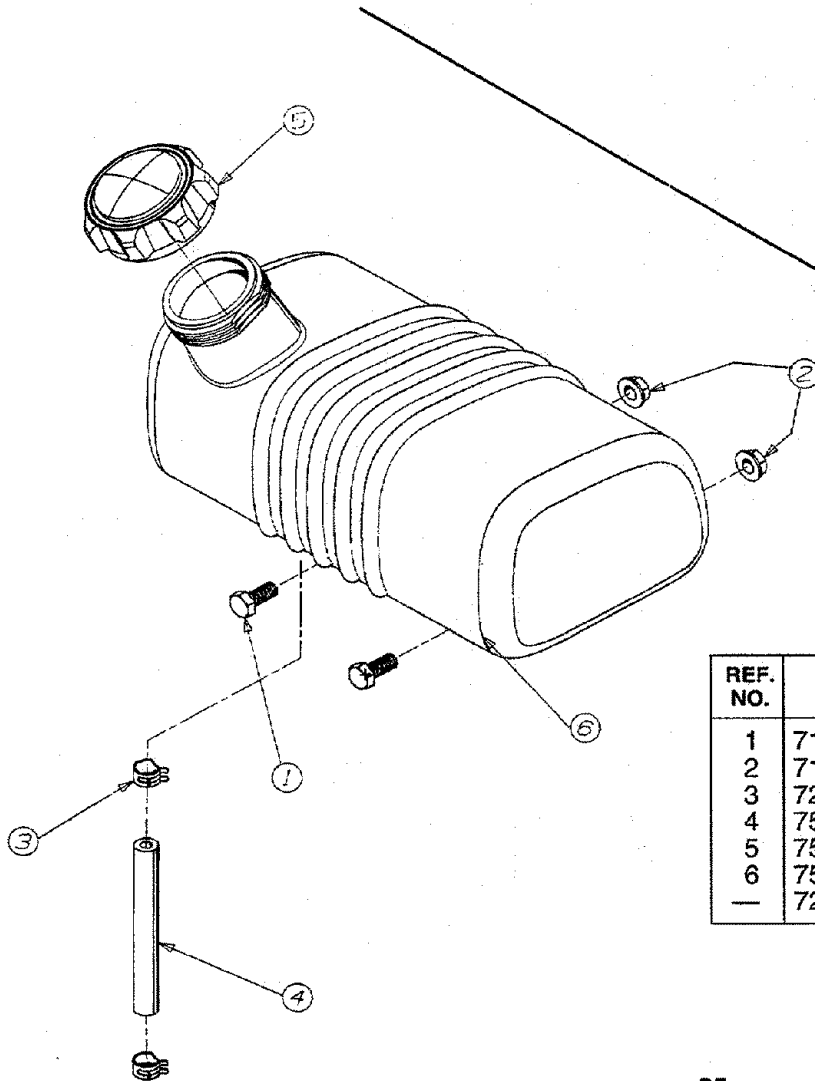
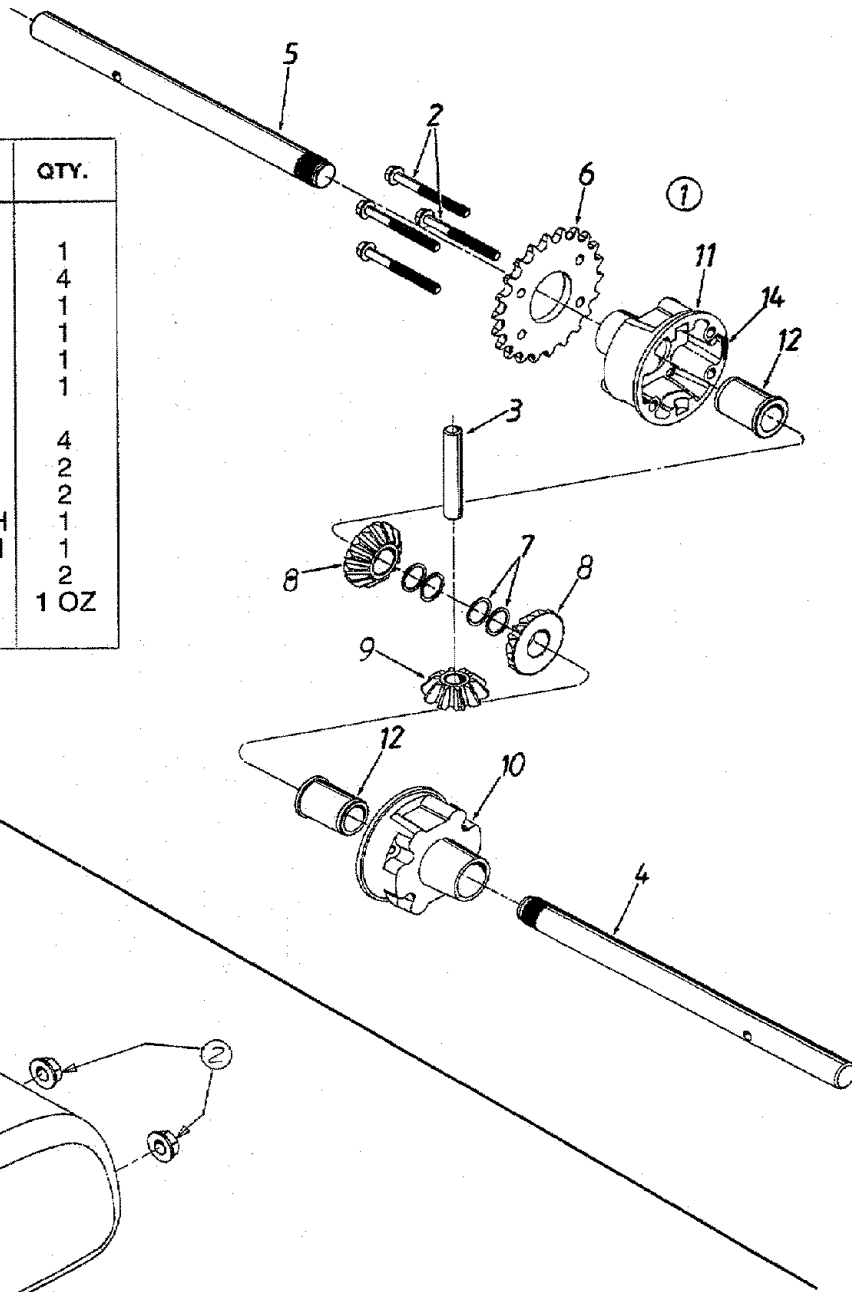

REF. NO.	PART NO.	DESCRIPTION	QTY.
1	710-3008	SCREW-HEX	2
2	712-3004A	NUT-HEX LOCK FLANGE	2
3	726-0205	CLAMP-HOSE	2
4	751-0535-8	HOSE-FUEL LINE 8"	1
5	751-0603	CAP-FUEL	1
6	751-0615	TANK-FUEL 1 GALLON	1
—	726-0209	CABLE TIE (NOT SHOWN)	1

SEARS CRAFTSMAN 9 H.P. ENGINE MODEL NO. 143.959003

Repair Parts

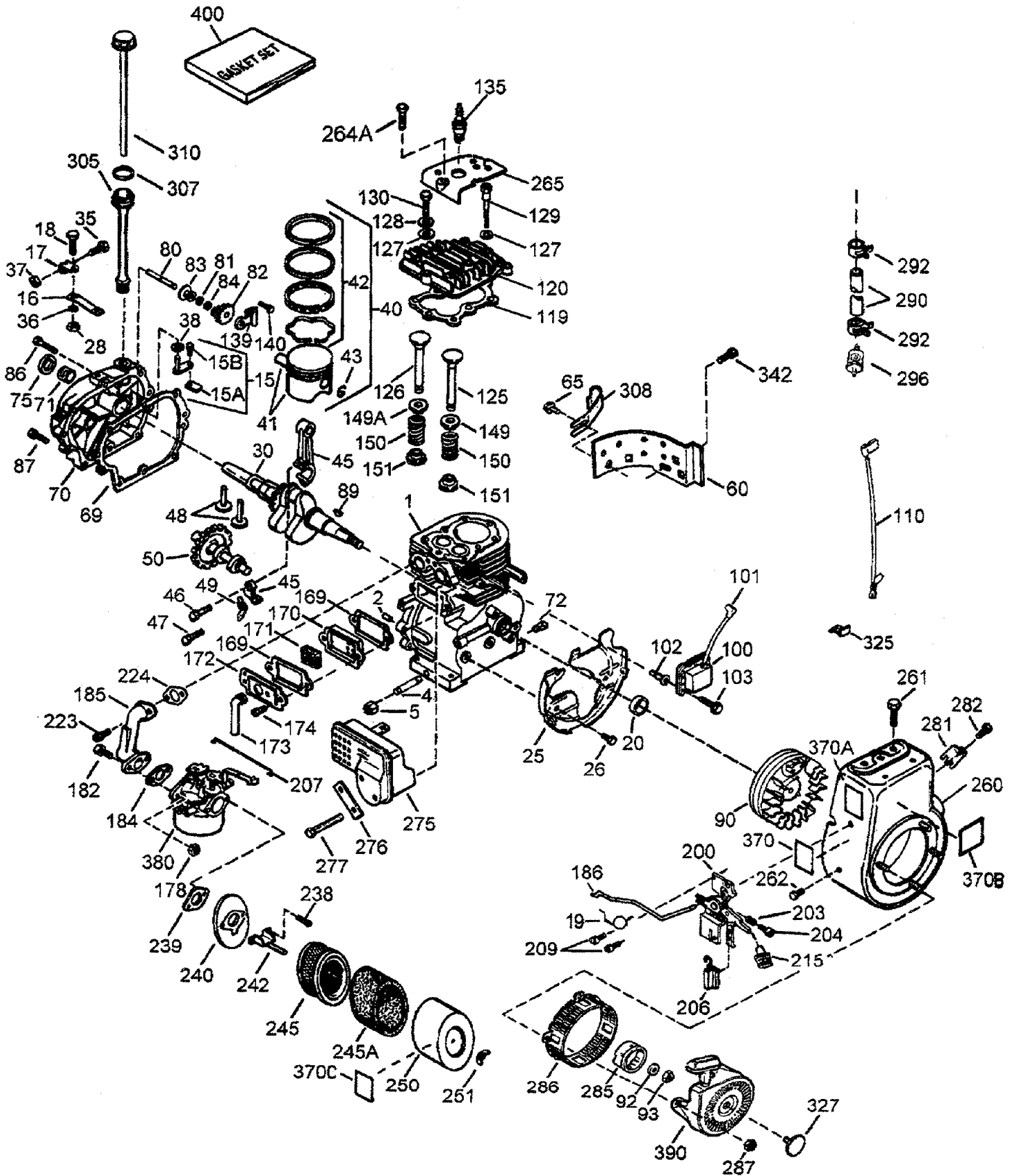

## SEARS CRAFTSMAN 9 H.P. ENGINE MODEL NO. 143.959003

## Repair Parts

KEY NO.	PART NO.	DESCRIPTION	KEY NO.	PART NO.	DESCRIPTION
1	35385	Cylinder (Incl. 2 & 20)	102	650872	Solid State Mounting Stud
2	27652	Dowel Pin	103	650814	Screw, Torx T-15, 10-24 x 1"
4	32678	Oil Drain Extension	110	35187	Ground Wire
5	30969	Extension Cap	119	36448	Cylinder Head Gasket
15	30699C	Governor Rod (Incl. 15A & 15B)	120	36449	Cylinder Head
15A	30700	Governor Yoke	125	27878A	Exhaust Valve (Std.) (Incl. 151)
15B	650494	Screw, 6-40 x 5/16"	125	27880A	Exhaust Valve (1/32" OS) (Incl. 151)
16	33454	Governor Lever	126	34035	Intake Valve (Std.) (Incl. 151)
17	29916	Governor Lever Clamp	126	34036	Intake Valve (1/32" OS) (Incl. 151)
18	650548	Screw, 8-32 x 5/16"	127	650691	Washer
19	34663	Speed Control Spring	128	650690	Belleville Washer
20	35319	Oil Seal	129	650738	Screw, 1/4-20 x 5/8"
25	36460	Blower Housing Baffle	130	650694A	Screw, 5/16-18 x 2"
26	650561	Screw, 1/4-20 x 5/8"	135	33636	Resistor Spark Plug (RJ17LM)
28	30322	Lock Nut, 8-32	139	33369	Governor Gear Bracket
30	36283	Crankshaft	140	650836	Screw, 10-24 x 1/2
35	29826	Screw, 10-32 x 3/4"	149	27882	Valve Spring Cap
36	29918	Lock Washer	149A	35862	Valve Spring Cap
37	29216	Lock Nut, 10-32	150	27881	Valve Spring
38	29642	Retaining Ring	151	32581	Valve Spring Keeper
40	34552	Piston, Pin & Ring Set (Std.)	169	27896A	Valve Cover Gasket
40	34553	Piston, Pin & Ring Set (.010" OS)	170	28423	Breather Body
40	34554	Piston, Pin & Ring Set (.020" OS)	171	28424	Breather Element
41	34329A	Piston & Pin Ass'y. (Std.) (Incl. 43)	172	28425	Valve Cover
41	34330A	Piston & Pin Ass'y. (.010" OS) (Incl. 43)	173	35350	Breather Tube
41	34331A	Piston & Pin Ass'y. (.020" OS) (Incl. 43)	174	650128	Screw, 10-24 x 1/2"
42	34332	Ring Set (Std.)	178	29752	Nut & Lock Washer, 1/4-28
42	34333	Ring Set (.010" OS)	182	30088A	Screw, 1/4-28 x 1"
42	34334	Ring Set (.020" OS)	184	33263	Carburetor To Intake Pipe Gasket
43	27888	Piston Pin Retaining Ring	185	34707	Intake Pipe
45	35373A	Connecting Rod Ass'y. (Incl. 46, 47 & 49)	186	34661	Governor Link
46	650908	Connecting Rod Bolt	200	34677	Control Bracket (Incl. 203 & 204)
47	650882	Connecting Rod Bolt	203	31342	Compression Spring
48	34034	Valve Lifter	204	650549	Screw, 5-40 x 7/16"
49	35374	Oil Dipper	206	610973	Terminal
50	36569	Camshaft (MCR)	207	33878	Throttle Link
60	33273A	Blower Housing Extension	209	650821	Screw, 10-32 x 1/2"
65	650128	Screw, 10-24 x 1/2"	215	32410	Control Knob
69	35262A	Cylinder Cover Gasket	223	650378	Screw, Torx T-30, 5/16-18 x 1-1/8"
70	35445A	Cylinder Cover (Incl. 71, 75 & 80)	224	27915A	Intake Pipe Gasket
71	35377	Crankshaft Bushing	238	28820	Screw, 10-32 x 1/2"
72	27642	Oil Drain Plug	239	27272A	Air Cleaner Gasket
75	35319	Oil Seal	240	33266	Air Cleaner Body
80	31845	Governor Shaft	242	33267	Air Cleaner Bracket
81	30590A	Washer	245	33268	Air Cleaner Filter
82	35378	Governor Gear Ass'y. (Incl. 81)	245A	35881	Air Cleaner Filter
83	30588A	Governor Spool	250	33269A	Air Cleaner Cover
84	29193	Retaining Ring	251	650513	Wing Nut, 1/4-20
86	650833	Screw, 1/4-20 x 1-3/16"	260	333750	Blower Housing
87	650832	Screw, 1/4-20 x 1-11/16"	261	650788	Screw, 5/16-18 x 3/4"
89	32589	Flywheel Key	262	29747B	Screw, Torx T-40, 5/16-24 x 21/32"
90	611090	Flywheel	264A	650802	Screw, 1/4-20 x 5/8"
92	650880	Lock Washer	265	33272B	Cylinder Head Cover
93	650881	Flywheel Nut	275	34185B	Muffler
100	35135	Solid State Ignition	276	31588	Locking Plate
101	610118	Spark Plug Cover	277	650729	Screw, 5/16-18 x 3-3/16"
			281	33013	Starter Bubble Cover
			282	650760	Screw, 8-32 x 3/8"
			285	35985B	Starter Cup

# SEARS CRAFTSMAN 9 H.P. ENGINE MODEL NO. 143.959003

## Repair Parts

KEY NO.	PART NO.	DESCRIPTION	KEY NO.	PART NO.	DESCRIPTION
286	35446	Starter Screen	370	36261	Instruction Decal
287	29752	Nut & Lock Washer, 1/4-28	370A	35703	Throttle Decal
290	30705	Fuel Line	370B	35532	Logo Decal
292	26460	Fuel Line Clamp	370C	35274	Instruction Decal
296	34279B	Starter Screen	380	632689	Carburetor (Incl. 184)
305	35554	Oil Fill Tube	390	590671	Rewind Starter
307	35499	"O"-Ring			Note: This engine could have been built with 590704 starter. Refer to the design of the air intake louvers for part identification. Individual starter parts do not interchange.
308	35540	Fill Tube Clip			
310	36205	Dipstick			
325	29443	Wire Clip			
327	35392	Starter Plug	400	36454	Gasket Set
342	30063	Screw, Torx T-30, 1/4-20 x 1/2"			

RPM Setting:  
High Speed: 3450 to 3750  
Low Speed: 1700

### OPTIONAL SPARK ARRESTER

Part No. 34479A

\*\* (Incl. Part Nos. 27272A, 27896A, 27915A, 29673, 33263, 33629, 34698A, 35262 & 36448)

KEY NO.	PART NO.	DESCRIPTION
—	632689	Carburetor (Incl. 184 of Engine Parts List)
1	632243	Throttle Shaft & Lever Assembly
2	632244	Throttle Return Spring
4	631184	Dust Seal Washer
5	631183	Dust Seal (Throttle)
6	632517	Throttle Shutter
7	650506	Shutter Screw
10	632249	Choke Shaft & Lever Assembly
11	632043	Choke Return Spring
12	631184	Dust Seal Washer
13	631183	Dust Seal (Choke)
14	632248	Choke Shutter
15	630735	Choke Positioning Spring
16	632164	Fuel Fitting
17	650417	Throttle Crack Screw/Idle Speed Screw
18	630766	Tension Spring
20	632281	Idle Mixture Screw
21	630766	Tension Spring
22	630739	Idle Mixture Screw Washer
23	630740	Idle Mixture Screw "O"-Ring
25	631867	Float Bowl
27	631024	Float Shaft
28	632019	Float
29	631028	Float Bowl "O"-Ring
30	631021	Inlet Needle, Seat & Clip (Incl. 31)
31	631022	Spring Clip
40	632239	Main Adj. Screw Ass'y. (Incl. 41 thru 44)
41	630740	High Speed Mixture Screw "O"-Ring
42	630739	High Speed Mixture Screw Washer
43	630738	High Speed Mixture Screw Tension Spring
44	27110	Bowl Nut Washer
47	630748	Welch Plug, Idle Mixture Well
48	631027	Welch Plug, Atmospheric Vent
60	632347	Repair Kit* (Incl. Items Marked PK in Notes)

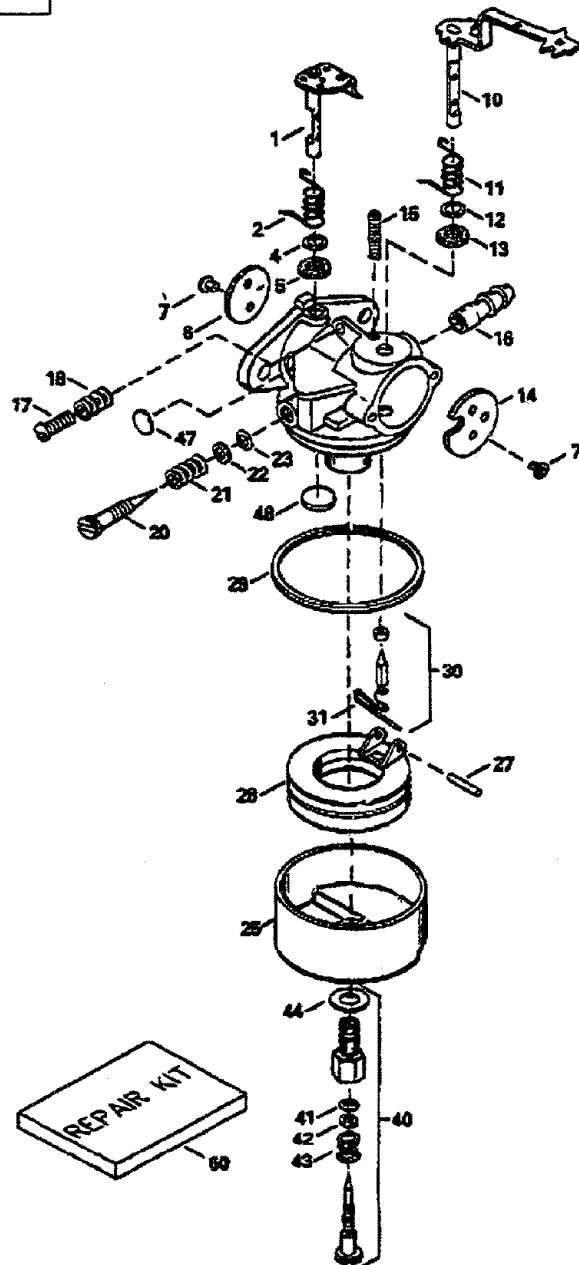

**SEARS CRAFTSMAN 9 H.P. ENGINE MODEL NO. 143.959003**

**Repair Parts**

**PARTS LIST FOR RECOIL STARTER**

KEY NO.	PART NO.	DESCRIPTION
—	590671	Recoil Starter
1	590599A	Spring Pin (Incl. 4)
2	590600	Washer
3	590679	Retainer
4	590601	Washer
5	590678	Brake Spring
6	590680	Starter Dog
7	590412	Dog Spring
8	590681	Pulley & Rewind Spring Ass'y.
11	590683	Starter Housing Ass'y.
12	590456	Starter Rope (114" x 11/64" Dia.)
13	590387	Starter Handle

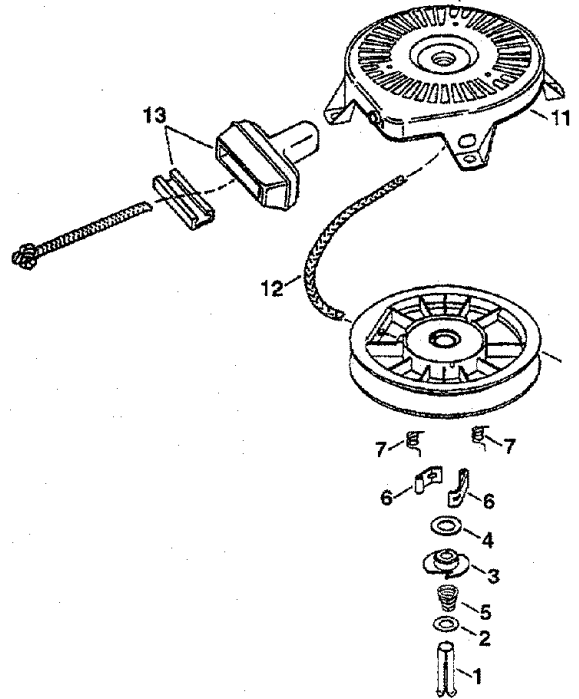

**PARTS LIST FOR RECOIL STARTER (OPTIONAL)**

KEY NO.	PART NO.	DESCRIPTION
—	590704	Recoil Starter
1	590599A	Spring Pin (Incl. 4)
2	590600	Washer
3	590696	Retainer
4	590601	Washer
5	590697	Brake Spring
6	590698	Starter Dog
7	590699	Dog Spring
8	590700	Pulley & Rewind Spring Ass'y.
11	590705	Starter Housing Ass'y.
12	590535	Starter Rope (98" x 9/64" Dia.)
13	590701	Starter Handle

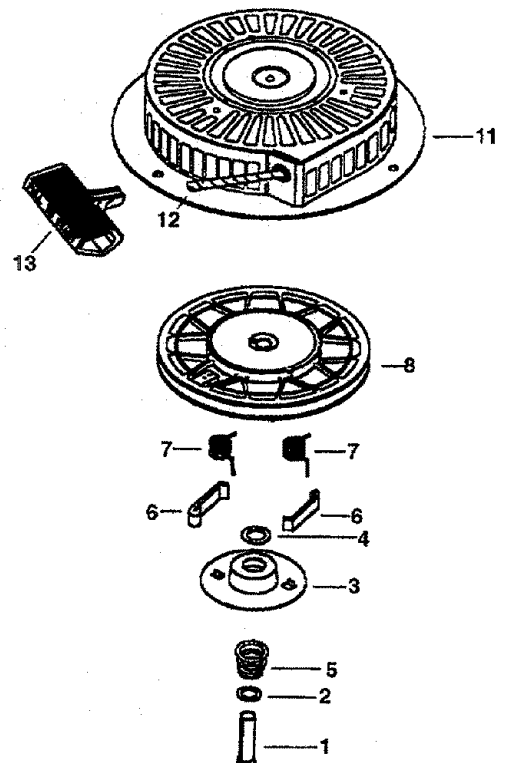

Seal kits for the new cylinders are the same as for the old cylinders, as all the internal components are the same.

bore diam	old cylinder	new cylinder	seal kit
4.0"	718-0307	718-0773	753-0490
4.5"	718-0306	718-0769	753-0563

**To: DISTRIBUTORS & AUTHORIZED SERVICE DEALERS**

**Re: LOG SPLITTER SEAL KITS**

As of February 1, 1999, log splitter cylinders under warranty capable of being repaired with a seal kit **must be repaired**. Any cylinders replaced under warranty will be called back for inspection. Any cylinder found to be repairable will be returned to the dealer and the dealer will be charged back the amount paid on the claim for the cylinder. Labor already paid will not be charged back. If replacement is determined to have been the only solution to the problem, no action will be taken. If you have any questions regarding this policy or how to handle a situation please contact MTD service.

If you need a pressure test kit (part # 759-3742), contact your central distributor. This kit includes an instructional video and is available for loan or purchase. You will be reimbursed for the cost of shipping and handling on a warranty job if you used a test kit on loan and include the amount on the claim form.

Seal kits are as follows.

**Fisher cylinders (retaining ring end cap):**

*NEW*  
718-0769  
718-0773

CYLINDER NUMBER	CYLINDER I.D.	SEAL KIT
<i>OLD</i> → 718-0306	4.5"	753-0563
<i>OLD</i> → 718-0307	4.0"	753-0490
718-0312	4.25"	753-0637
718-0313	5.0"	753-0564

→ SAME FOR NEW + OLD.

**Best Metal cylinders (thread on end cap):**

CYLINDER NUMBER	CYLINDER I.D.	SEAL KIT
718-0307	4.0"	753-0689
718-0313	5.0"	753-0691

**Procedure for Resealing Hydraulic Cylinders  
(On Machine - Fisher Cylinders - Snap-Ring Type)**

1. Clean cylinder, wedge and beam area.
2. Fully retract cylinder rod into cylinder - stop engine.
3. With engine off, move control valve back and forth several times to be sure there is no pressure in system.
4. With a clean catch container in place, disconnect pump to control valve hose from pump fitting and insert end into container. Plug fitting on pump with plastic cap or tape. This is to prevent dirt from entering fitting.
5. Remove (4) 3/4" bolts securing the log dislodger and remove dislodger.
6. Remove 1/2" bolt through wedge and cylinder rod. Slide wedge all the way forward on the beam till it meets the base plate. No need to remove wedge from beam.
7. Lift rod up and place wood block under cylinder barrel to hold assembly at an angle. This will allow for rod removal.
8. Place control valve into detent position
9. Using a wood dowel or a hammer handle, tap cylinder rod cap into cylinder just beyond the snap ring. Do not go any farther than necessary as it will make further disassembly very difficult. Remove snap ring from groove being careful not to scratch groove or bore. If you do, you must polish scratched area with fine emery so scratch won't damage new seals as they pass the area. It is an easy job if you tap one end of snap ring into the cylinder first, and then get a medium screwdriver under the ring to pry it out.
10. Reconnect and tighten hose to pump.

11. **Very Important!!!!** You must clean any paint or rust in the bore area by sanding it off. The paint will be from the snap ring groove outward. After removing ALL paint and rust leaving a smooth surface, coat exposed area inside cylinder with grease. If you do not do this, further disassembly will be difficult and damage may result during reassembly!

**USE EXTREME CAUTION DURING NEXT STEP!!!**

12. Put control lever in neutral and start engine. **Set engine at low idle speed**, and use control valve lever to extend rod out of cylinder until cylinder rod cap just starts to move. **Put control lever in neutral, shut off engine and disconnect spark plug wire.**
13. Have someone hold control lever in extend position and pull engine starter rope to extend rod slowly until the cylinder rod cap can be pulled free of the cylinder. **Do not remove end cap from rod.**
14. Remove steel tube from fitting at end of cylinder and attach a ¼" I.D. hose to fitting on the cylinder using a hose clamp. Place other end of hose into catch container.
15. Push rod into cylinder using cylinder rod cap as a guide. This will force oil out of cylinder through hose and into container. Do not push turn down of rod into cylinder rod cap as damage to cap may result. Remove hose from cylinder.
16. You are now ready to pull rod and piston assembly from cylinder barrel. Be sure to have a piece of wood, thick cardboard or pile of rags on the beam so that when you pull the rod out of the cylinder the piston won't be damaged by dropping down on the beam. Install a suitable bar or large screwdriver through bolt hole in rod and pull rod, cylinder rod cap and piston out of cylinder.
17. Set rod and piston assembly on clean bench and with a light examine inside of cylinder barrel for gouges and scratches. If scratches exist you should replace the complete cylinder. Do not attempt to hone cylinder as any reduction of wall thickness can result in a safety problem. If no damage to cylinder is apparent, proceed with repair.
18. Prop cylinder up as close to vertical as possible with a wood block.
19. Bolt rod to wedge ram placing a wood block under rod to keep piston from hitting beam. Remove nut from piston end of rod and slide piston and cylinder rod cap off threaded end of rod.
20. Examine piston and rod cap for damage. Remove old seals, bearings and o-rings from rod, piston and cylinder rod cap. **Pay attention to alignment of seals as some are directional.** Be very careful not to scratch the walls of the seal grooves. Scratches can render the rod cap or piston unusable.
21. Using a tap and die or thread file, clean threads on rod and nut.
22. **Cleanliness is vital throughout reassembly!** Clean piston, rod, end cap and cylinder.
23. Lubricate seals and bearings with hydraulic oil and install them in end cap and piston.
24. Lubricate inside of cylinder rod cap and piston with general purpose grease and carefully install them on rod from threaded end being careful to start wiper lip onto rod and then working cylinder rod cap on. Any attempt to install the cap from the rod turn down end will result in seal lip damage.
25. Clean grease from exposed threads on rod and install piston nut on rod using red Loctite. Torque nut to 300 - 325 ft.-lbs. and restake in place to prevent the nut from backing off.
26. Remove rod assembly from wedge and set aside in a clean place being careful not to damage seals. Lower cylinder to angle at which rod may be reinserted.
27. Lubricate inside of cylinder with hydraulic oil and grease the end cap and piston.
28. Insert piston into cylinder being careful to not damage seals. Slide assembly in until piston is approximately 12" into barrel, then slide rod cap into cylinder and tap it in just past snap ring groove. Do not go farther than necessary to install snap ring as damage to seals may occur. Install snap ring.
29. Place control valve in neutral. Reattach tube to cylinder and wedge to rod.
30. Add oil to tank to within 1" from top. Start engine and slowly cycle control valve several times to fill cylinder. There will be a loud "POP" as cylinder rod cap seats over snap ring. (Cylinder may act jumpy until cylinder self purges of air.) When cylinder is full, retract ram fully and stop engine. Top off oil to within 1.5" to 2" from top of tank.
31. Remove wedge from rod and prop cylinder up again. Clean and paint area of cylinder bore you originally sanded.
32. Complete reassembly, cycle unit and check for leaks. If possible, test on a few logs.