

Use & Care Guide

Freezer

Guía de Uso y Cuidado

Congelador

Guide d'utilisation et d'entretien

Congélateur

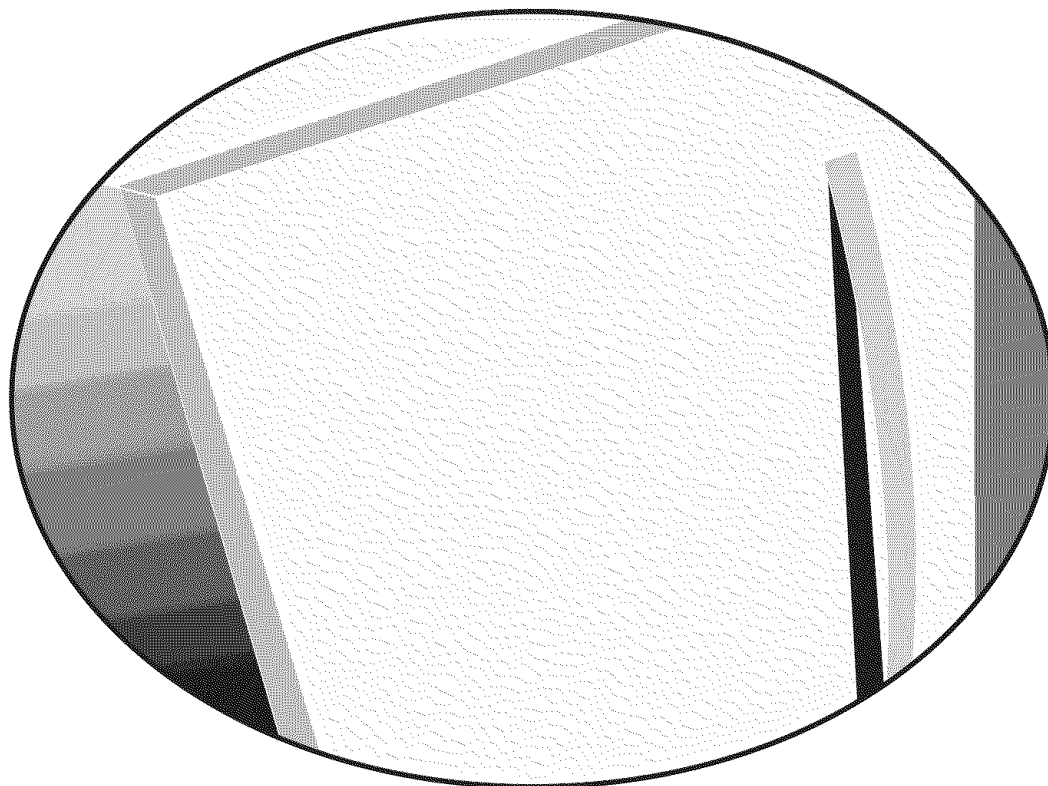

2 Finding Information

PLEASE READ AND SAVE THIS GUIDE

Attach your sales receipt to this page for future reference.

Thank you for choosing **Electrolux**, the new premium brand in home appliances. This *Use & Care Guide* is part of our commitment to customer satisfaction and product quality throughout the service life of your new freezer.

We view your purchase as the beginning of a relationship. To ensure our ability to continue serving you, please use this page to record key product information.

MAKE A RECORD FOR QUICK REFERENCE

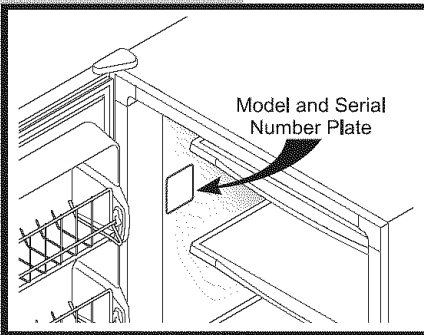

Purchase Date _____

Electrolux Model Number _____

Electrolux Serial Number (*see picture for location*) _____

NOTE

Registering your product with Electrolux enhances our ability to serve you. You can register online (at the Internet address below) or by dropping your Product Registration Card in the mail.

QUESTIONS?

For toll-free telephone support in the U.S. and Canada:
1-877- 4ELECTROLUX (1-877-435-3287)

For online support and Internet product information:
www.electroluxusa.com

©2006 Electrolux Home Products, Inc.
Post Office Box 212378, Augusta, Georgia 30917, USA
All rights reserved. Printed in the USA

TABLE OF CONTENTS

Finding Information	2	Storing Food & Saving Energy	13
Please Read And Save This Guide	2	Energy Saving Ideas	13
Make A Record For Quick Reference	2	Vacation and Moving Tips	13
Questions?	2	Short Vacations	13
Table Of Contents	3	Long Vacations	13
		Moving	13
Safety 4		Power Failure / Freezure Failure	14
Important Safety Instructions	4	Ice Service	15
Electrical Information	5	Turning your Ice Maker On	15
Feature Overview	6	Turning your Ice Maker Off	15
Understanding Features And Terms	6	Ice Maker Tips	15
Installation	7	Care and Cleaning	16
Installation	7	Care and Cleaning Chart	17
Door Opening	7	Warranty Information	18
Leveling	7	Solutions To Common Problems	19
To Level Freezer	8	Troubleshooting Guide	19-20
Leveling Instructions for all Refrigerator/ Freezer Pair	8		
Door Removal	9		
Ice Maker Installation	9		
Setting the Temperature Controls	9		
Cool Down Period	9		
Electronic Temperature Control	9		
Freezer Features	10		
Interior Lighting	10		
Mid Level Lighting	10		
Storage	11		
Spill Safe Slide-out Glass Shelving	11		
To Adjust the Shelves	11		
Tilt-out Shelf	-		
Air Filter	12		
To Replace Air Filter	12		

4 Safety

IMPORTANT SAFETY INSTRUCTIONS

WARNING

Please read all safety instructions before using your new Electrolux freezer.

General Safety

- Do not store or use gasoline, or other flammable liquids, near this or any other appliance. Read product labels for warnings regarding flammability and other hazards.
- Do not operate the freezer in the presence of explosive fumes.

Child Safety

- Destroy carton, plastic bags, and any exterior wrapping material immediately after the freezer is unpacked. Children should never use these items to play. Cartons covered with rugs, bedspreads, plastic sheets or stretch wrap may become airtight chambers and can quickly cause suffocation.
- Remove all staples from the carton. Staples can cause severe cuts, and destroy finishes if they come in contact with other appliances or furniture.
- An empty, discarded ice box, refrigerator or freezer is a very dangerous attraction to children.
- Remove or discard any spacers used to secure the shelves during shipping. Small objects are a choke hazard to children.
- Remove the door(s) of any appliance that is not in use, even if it is being discarded.

Proper Disposal Of Refrigerators And Freezers

RISK OF CHILD ENTRAPMENT

Child entrapment and suffocation are not problems of the past. Junked or abandoned refrigerators or freezers are still dangerous - even if they will sit for "just a few days". If you are getting rid of your old refrigerator or freezer, please follow the instructions below to help prevent accidents:

- Remove the door(s).
- Leave shelves in place so children may not easily climb inside.
- Have the refrigerant removed by a qualified technician.

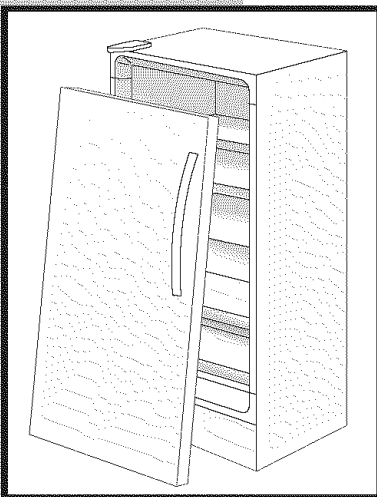

ELECTRICAL INFORMATION

WARNING

You must follow these guidelines to ensure that your freezer's safety mechanisms are operating correctly.

- **Refer to the serial plate for correct electrical rating.** The power cord of the freezer is equipped with a three-prong grounding plug for protection against shock hazards. It must be plugged directly into its own properly grounded three-prong receptacle, protected with a 15 amp time delay fuse or circuit breaker. The power supply circuit must be installed in accordance with current edition of the National Electrical Code (NFPA 70) and local codes and ordinances. Consult a qualified electrician. Receptacles protected by Ground Fault Circuit Interrupters (GFCI) are NOT RECOMMENDED. **DO NOT USE AN EXTENSION CORD OR AN ADAPTER PLUG.**
- If the voltage varies by 10 percent or more, freezer performance may be affected. Operating the freezer with insufficient power can damage the motor. Such damage is not covered under the warranty. If you suspect your household voltage is high or low, consult your power company for testing.
- To prevent the freezer from being turned off accidentally, do not plug the unit into an outlet controlled by a wall switch or pull cord.
- Unplug the freezer before cleaning and before replacing a light bulb to avoid electrical shock.
- Do not pinch, knot, or bend the power cord in any manner.

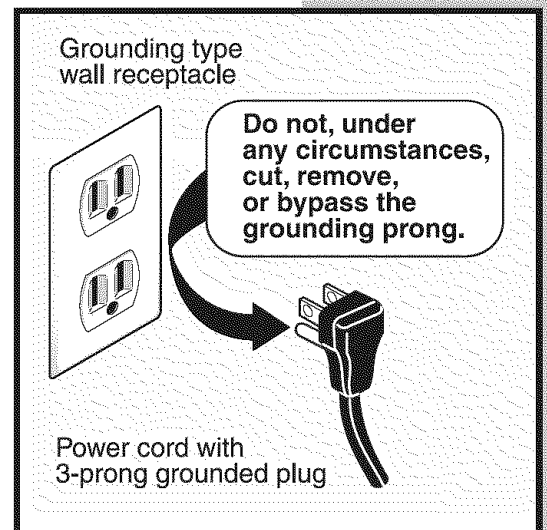

Other Precautions

- Never unplug the freezer by pulling on the power cord. Always grip the plug firmly and pull straight out from the receptacle.
- Turning the control to "OFF" turns off the compressor but does not disconnect power to the light bulb or other electrical components.

WARNING

Avoid fire hazard or electric shock. Do not use an extension cord or an adapter plug. Do not remove any prong from the power cord.

6 Feature Overview

UNDERSTANDING FEATURES AND TERMS

Your Electrolux freezer is designed for optimal convenience and storage flexibility. Use the illustration below to familiarize yourself with product features and terminology.

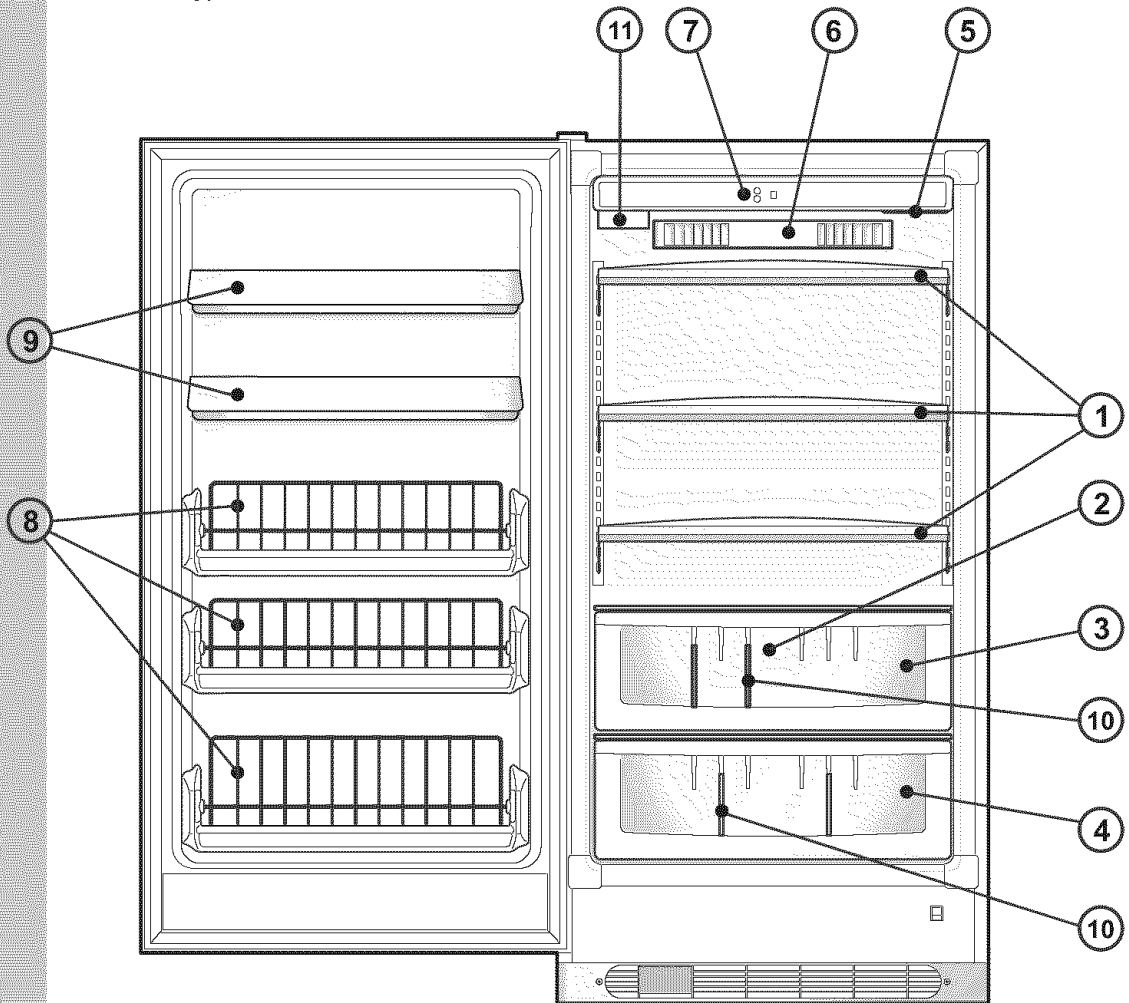

1	SPILL SAFE SLIDE OUT GLASS SHELF	7	ELECTRONIC CONTROLS
2	MID LEVEL LIGHTING (BACK OF CRISPER)	8	TILT-OUT SHELF
3	SMOOTH GLIDE DRAWER (UPPER)	9	ADJUSTABLE DOOR BIN
4	SMOOTH GLIDE DRAWER (LOWER)	10	ADJUSTABLE CRISPER DIVIDER
5	AIR FILTER	11	ICE MAKER
6	AIR DIFFUSER		

NOTE

Features may vary according to model.

This Owner's Guide provides specific operating instructions for your model. Use the freezer only as instructed in this Owner's Guide. **Before starting the freezer, follow these important first steps.**

INSTALLATION

- Choose a place that is near a grounded electrical outlet. **DO NOT use an extension cord or an adapter plug.**
- For most efficient operation, the freezer should be located where surrounding temperatures will not drop below 40°F (5°C) or exceed 110°F (43°C).
- Allow the following clearances for ease of installation, proper air circulation, and electrical connections:

Sides	3/8 inch
Back & Top	1 inch
- Do not block the toe grille on the lower front of your freezer. Sufficient air circulation is essential for the proper operation of your freezer.

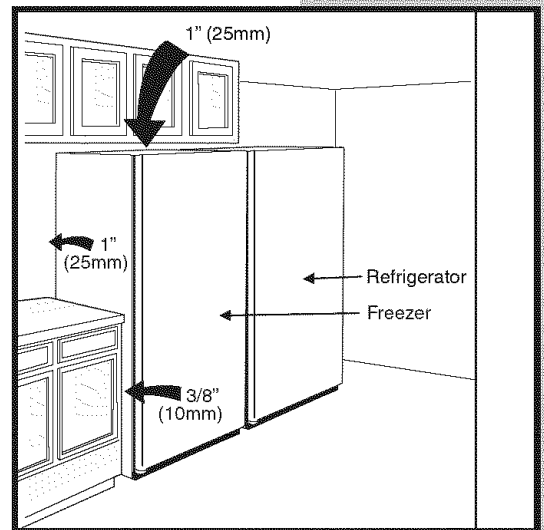

NOTE

The exterior walls of the freezer may become quite warm as the compressor works to transfer heat from the inside. Temperatures as much as 30°F warmer than room temperature can be expected.

Door Opening

NOTE

If your freezer is placed with the door hinge side against a wall, you may have to allow additional space so the door can be opened wider.

Leveling

The freezer must have all bottom corners resting firmly on a solid floor. The floor must be strong enough to support a fully loaded freezer. It is **VERY IMPORTANT** for your freezer to be level in order to function properly. If the freezer is not leveled during installation, the door may be misaligned and not close or seal properly, causing cooling, frost or moisture problems.

8 Installation

To Level Freezer:

After discarding crating screws and wood base, use a carpenter's level to level the freezer from front to back. Adjust the plastic leveling feet in front, 1/2 bubble higher, so that the door closes easily when left halfway open.

Leveling Instructions For All Refrigerator / Freezer Pair:

- Remove two leg levelers provided in literature bag. While unit is lying on its back for wood skid removal, install both leg levelers in rear of unit.
- Level door of first unit using all four levelers and slide unit into place. Recheck for levelness and adjust if necessary.
- Measure distance from floor to bottom of door on first unit. Adjust and level second unit so door height matches.
- Leg Level Adjustments:
 - One full turn of all four leg levelers will raise door 5/32".
 - One full turn of both front leg levelers will raise door 3/16" and tilt top of door back 7/16".
 - One full turn of both rear leg levelers will lower door 1/32" and tilt top of door forward 7/16".
 - One full turn of both side leg levelers will raise door 3/16" and tilt top of door 3/8".
- Slide second unit into place leaving a minimum gap of 3/16" between units for door swing clearance.
- This last step may require at least one extraction of the second unit to properly align units in a "built-in" application.

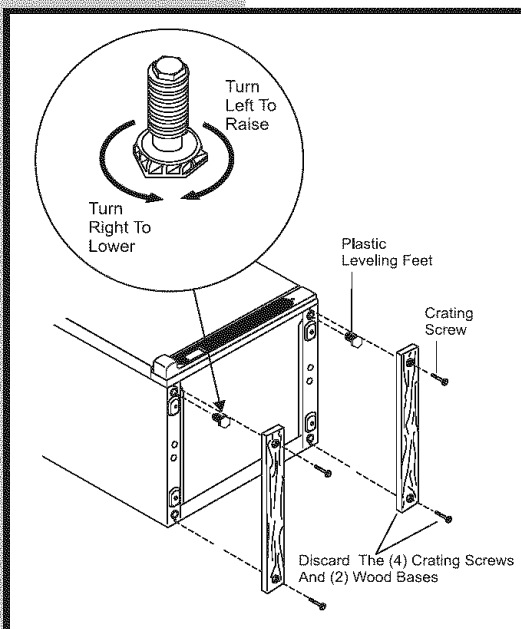

CAUTION

To allow door to close and seal properly, do not let food packages extend past the front of the shelves.

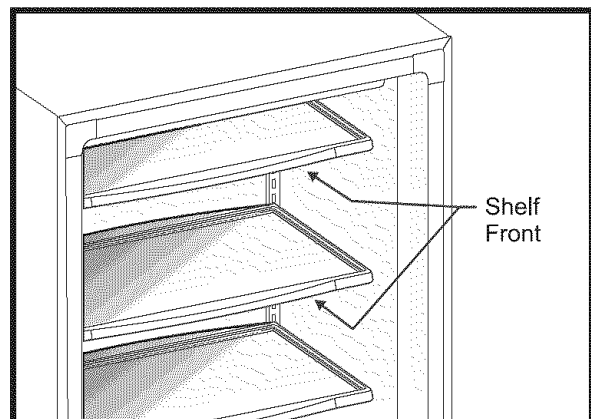

Door Removal

If door must be removed:

- Unplug the unit
- Gently lay freezer on its back, on a rug or blanket.
- Remove two base screws and base panel. Remove wire from clips on bottom of cabinet, if required.
- Unplug connector, if required, by holding the cabinet connector in place and pulling the door connector out.
- Remove the bottom hinge screws.
- Remove the plastic top hinge cover.
- Remove the screws from the top hinge.
- Remove the top hinge from the cabinet.
- Remove the door and bottom hinge from the cabinet.
- To replace door, reverse the above procedures and securely tighten all screws to prevent hinge slippage.

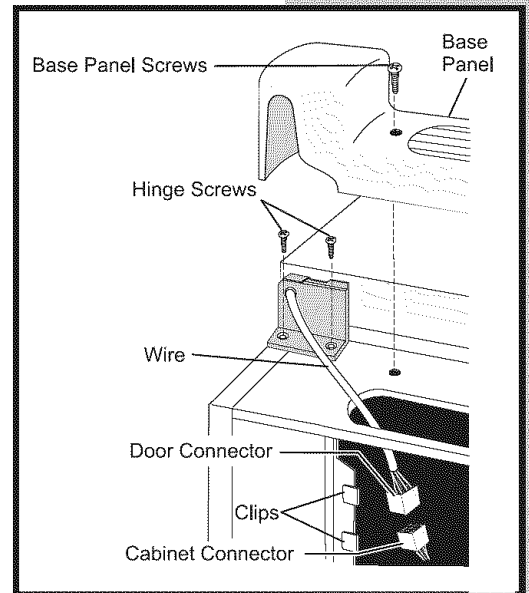

Ice Maker Installation

If your freezer has an automatic ice maker, please refer to the insert in the bond pack that came with your freezer (**CONNECTING ICE MAKER TO WATER SUPPLY**) to correctly hook-up your ice maker.

SETTING THE TEMPERATURE CONTROLS

Cool Down Period

For safe food storage, allow four (4) hours for freezer to cool down completely. The freezer will run continuously for the first several hours.

Electronic Temperature Control

The electronic temperature control is located inside the freezer. Temperature is factory preset to provide satisfactory food storage temperatures. However, the temperature control is adjustable to provide a range of temperatures for your personal satisfaction. To adjust the temperature setting, move the UP (▲) button for warmer temperature and DOWN (▼) button for colder temperature on the control panel. Allow several hours for the temperature to stabilize between adjustments.

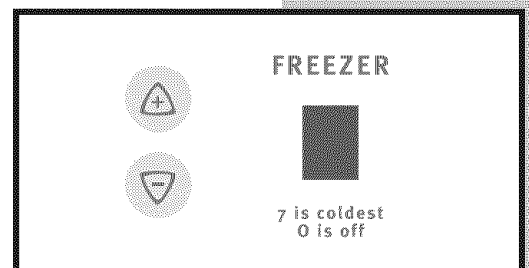

10 Freezer Features

INTERIOR LIGHTING

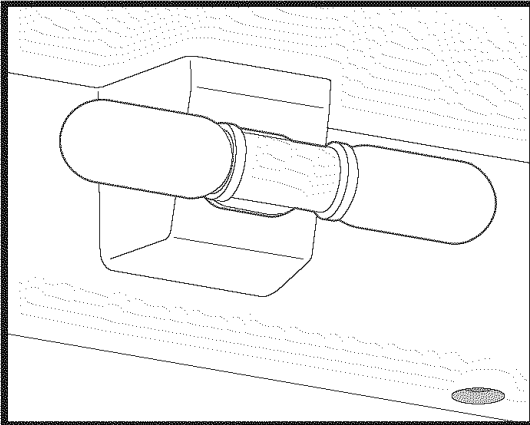

The light comes on automatically when the door is opened. The light bulb assembly is located on the back of the freezer control box. To replace the light bulb, turn the temperature control to "OFF" and unplug the electrical cord. Replace the old bulb with a bulb of the same type and wattage.

Mid Level Lighting

The mid level lighting is located at the back of the crispers. The lights come on automatically when the door is opened. To replace the light bulb, turn the temperature control to OFF and unplug the electrical cord. Remove the lens from

the lamp housing by unsnapping it from the lamp housing using your fingers or a screwdriver. Be careful not to break the locking tabs on the lamp housing. Replace the old bulb with a bulb of the same type and wattage. To replace the lens, snap one side of the lens opening to the tab on the lamp housing. Then carefully attach the other side.

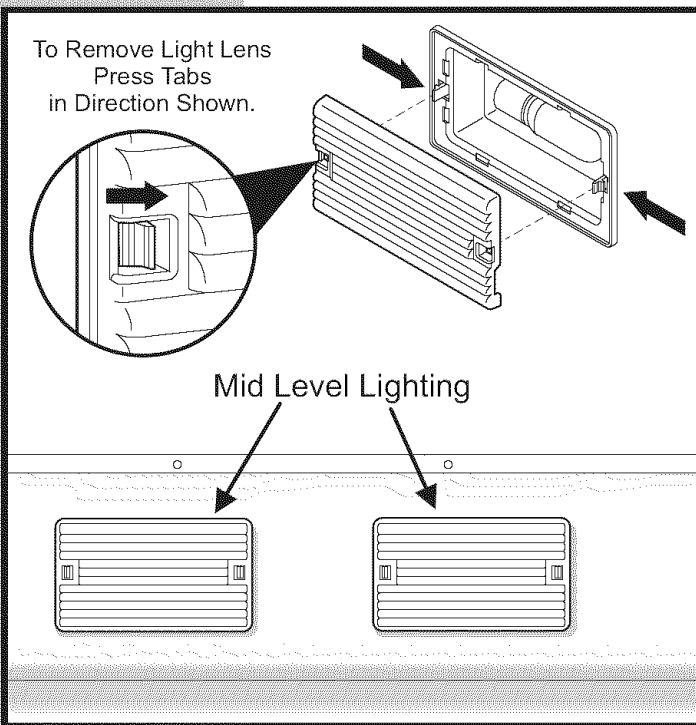

STORAGE

Spill Safe Slide-out Glass Shelving

Multi-position adjustable slide out glass shelves can be moved to any position for larger or smaller packages. The shipping spacers that stabilize the shelves for shipping may be removed and discarded.

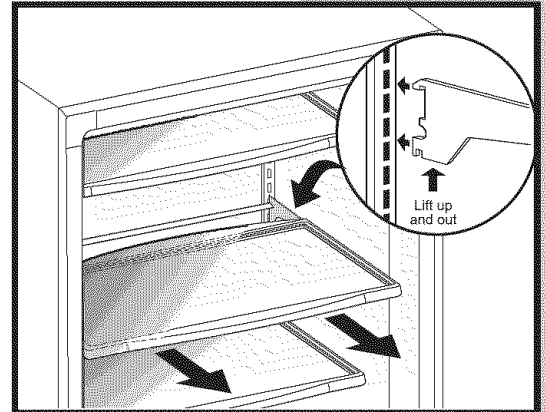

To Adjust The Shelves

- Lift front edge up.
- Pull shelf out
- Replace the shelf by inserting the hooks at rear of the shelf into the wall bracket. Lower the shelf into the desired slots and lock into position.

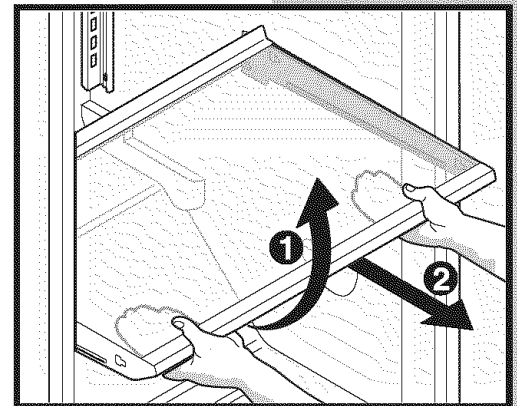

Smooth Glide Crispers With Adjustable Dividers

The crispers, located at the bottom of the freezer shelf, provide separate space for items that are difficult to store on freezer shelves. Dividers may be adjusted for different size items within the crisper.

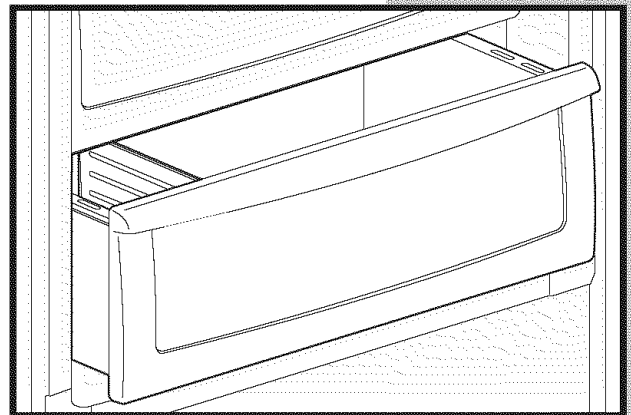

12 Freezer Features

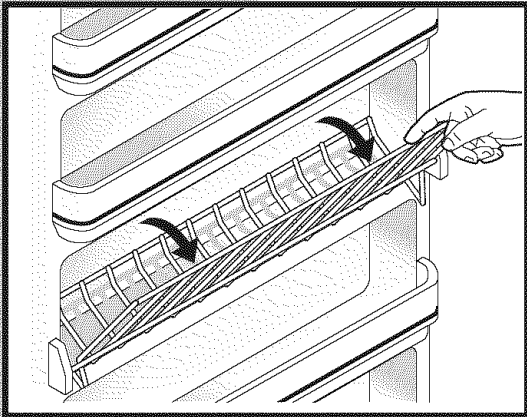

Tilt - Out Shelf

This shelf is located inside on the freezer door and provides additional storage space. To access an item, tilt the top of "basket" shelf down.

AIR FILTER

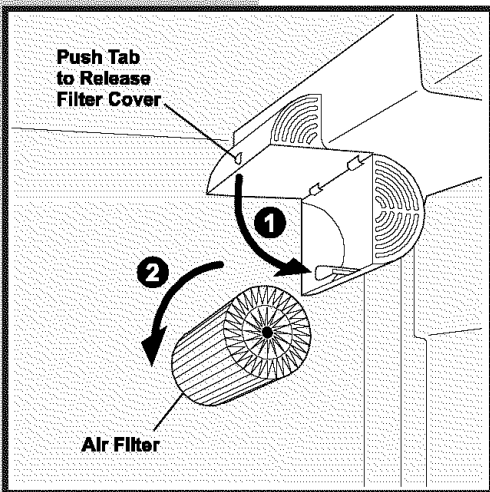

The air filter is located on the back of the control box. In general, you should change the air filter every six months to ensure optimal filtering of refrigerator odors. You may want to adjust this time period depending on the types and amounts of food you typically store in your refrigerator.

To Replace The Air Filter:

- Push the plastic bubble tab at the back of the control box housing. This releases the hinged bottom half to drop open.
- Remove the old filter and discard it.
- Unpackage the new filter and place it inside the hinged bottom half of the housing.
- Push the hinged bottom half upward until the tab snaps into closed position.

ENERGY SAVING IDEAS



- Locate the freezer in the coolest part of the room, out of direct sunlight, and away from heating ducts or registers. Do not place the freezer next to heat-producing appliances such as a range, oven, or dishwasher. If this is not possible, a section of cabinetry or an added layer of insulation between the two appliances will help the freezer operate more efficiently.

- Level the freezer so that the door closes tightly.
- Refer to the "**SETTING THE TEMPERATURE CONTROL**" section for the suggested temperature control settings.
- Do not overcrowd the freezer or block cold air vents. Doing so causes the freezer to run longer and use more energy.
- Cover foods and wipe containers dry before placing them in the freezer. This cuts down on moisture build-up inside the unit.
- Organize the freezer to reduce door openings. Remove as many items as needed at one time and close the door as soon as possible.

VACATION AND MOVING TIPS

Short Vacations:

- Leave the freezer operating during vacations of less than three weeks.

Long Vacations:

If the freezer will not be used for several months:

- Remove all food and unplug the power cord.
- Clean and dry the interior thoroughly.
- Leave the freezer door open slightly, blocking it open if necessary, to prevent odor and mold growth.

Moving: When moving the freezer, follow these guidelines to prevent damage:

- Disconnect the power cord plug from the wall outlet.
- Remove foods, then defrost, and clean the freezer.

14 Storing Food & Saving Energy

- Secure all loose items such as base panel, baskets, and shelves by taping them securely in place to prevent damage.
- In the moving vehicle, secure freezer in an upright position to prevent movement. Also protect outside of freezer with a blanket, or similar item.

POWER FAILURE / FREEZER FAILURE

NOTE

Do not open freezer door unnecessarily if freezer is off for several hours.

If a power failure occurs, frozen foods will stay frozen for at least 24 hours if the freezer is kept closed. If the power failure continues, pack seven or eight pounds of dry ice into the freezer every 24 hours. Look in the Yellow Pages under Dry Ice, Dairies or Ice Cream Manufacturers for local dry ice suppliers. Always wear gloves and use caution when handling dry ice.

If the freezer has stopped operating, see "**FREEZER DOES NOT RUN**" in the "**TROUBLESHOOTING GUIDE**" section. If you cannot solve the problem, call Sears Service immediately.

If the freezer remains off for several hours, follow the directions above for the use of dry ice during a power failure. If necessary, take the food to a local locker plant until the freezer is ready to operate. Look in the Yellow Pages under Frozen Food Locker Plants.

ICE SERVICE

If your freezer has an automatic icemaker, it will provide a sufficient supply of ice for normal use. During the initial startup of your freezer, however, no ice will be produced during the first 24 hours of operation. Automatic ice makers are also optional accessories that may be installed in some models at any time. Call your local dealer for information.

Turning Your Ice Maker On

After the plumbing connections have been completed, the water supply valve must be opened. Place the ice container under the ice maker, pushing it as far back as possible. Lower the wire signal arm to its "down" or ON position. New plumbing connections may cause the first production of ice cubes to be discolored or have an odd flavor. These first cubes should be discarded until the cubes produced are free of discoloration and taste.

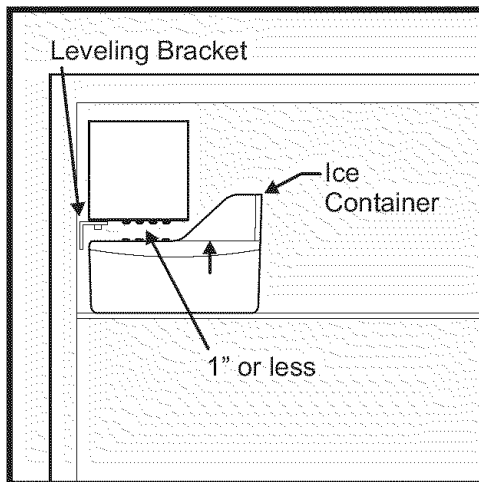
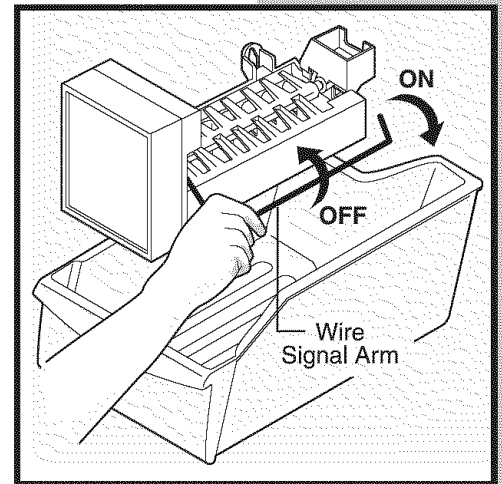

Turning Your Ice Maker Off

To stop the ice maker, lift the wire signal arm until it clicks and locks in the "up" or OFF position. The ice maker also turns off automatically when the ice container is full. If your model has an adjustable freezer shelf, place the shelf in the lower position, so that the wire signal arm will hit the ice when the container is full.

IMPORTANT

Your ice maker is shipped with the wire signal arm in the ON position. To ensure proper function of your ice maker, hook up water supply immediately or turn ice maker OFF by lifting the wire signal arm until it clicks and locks in the UP position.

Check the leveling bracket on the ice maker to ensure the ice maker is level. If the gap between the freezer wall and the ice maker is the same at top and bottom, then ice maker is level. If the ice maker is not level, loosen the screw and slide the bracket to the correct position to make it level. Retighten the screw. You will need a 1/4 inch socket wrench for this task.

Ice Maker Tips

- Ice cubes stored too long may develop an odd flavor. Empty the ice container and ensure that the wire signal arm is in its "down" or ON position. The ice maker will then produce more ice.
- Occasionally shake the ice container to keep ice separated.
- Keep the wire signal arm in its "up" or OFF position until the freezer is connected to the water supply or whenever the water supply is turned off.
- The following sounds are normal when the ice maker is operating:
 - Motor running
 - Ice loosening from tray
 - Ice dropping into ice container
 - Running water
 - Water valve opening or closing



CAUTION

- **DO NOT place the ice container in your dishwasher**
- **Wash the ice container in warm water with mild detergent. Rinse well and dry.**
- **Stop the ice maker when cleaning the freezer and during vacations.**
- **If the ice maker will be turned off for a long period of time, turn the water supply valve to the closed position.**

CARE AND CLEANING

Keep your freezer clean to prevent odor build-up. Wipe up any spills immediately and clean at least twice a year. Never use metallic scouring pads, brushes, abrasive cleaners or strong alkaline solutions on any surface. Do not wash any removable parts in a dishwasher. Always unplug the electrical power cord from the wall outlet before cleaning.



CAUTION

- When moving the freezer, pull straight out. Do not shift the freezer from side to side as this may tear or gouge the floor covering.
- Damp objects stick to cold metal surfaces. Do not touch interior metal surfaces with wet or damp hands.

NOTE

- Turning the freezer temperature control to "OFF" turns off the compressor, but does not disconnect electrical power to the light bulb or other electrical components. To turn off power to your freezer, you must unplug the power cord from the wall outlet.
- Do not use razor blades or other sharp instruments which can scratch the appliance surface when removing adhesive labels. Any glue left from tape or labels can be removed with a mixture of warm water and mild detergent, or, touch the glue residue with the sticky side of tape you have already removed. Do not remove the serial plate.

Care And Cleaning Chart

Part	Cleaning Agents	Tips and Precautions
Interior & Door Liners	<ul style="list-style-type: none"> • Soap and water • Baking soda and water 	<ul style="list-style-type: none"> • Use 2 tablespoons of baking soda in 1 quart of warm water. • Be sure to wring excess water out of sponge or cloth before cleaning around controls, light bulb or any electrical part.
Door Gaskets	<ul style="list-style-type: none"> • Soap and water 	<ul style="list-style-type: none"> • Wipe gaskets with a clean soft cloth.
Drawers & Bins	<ul style="list-style-type: none"> • Soap and water 	<ul style="list-style-type: none"> • Use a soft cloth to clean drawer runners and tracks. • Do not wash any removable items (bins, drawers, etc.) in dishwasher.
Glass Shelves	<ul style="list-style-type: none"> • Soap and water • Glass cleaner • Mild liquid sprays 	<ul style="list-style-type: none"> • Allow glass to warm to room temperature before immersing in warm water.
Exterior & Handles	<ul style="list-style-type: none"> • Soap and water • Non Abrasive Glass Cleaner 	<ul style="list-style-type: none"> • Do not use commercial household cleaners, ammonia, or alcohol to clean handles. • Use a soft cloth to clean smooth handles. • Do not use a dry cloth to clean smooth doors.
Exterior & Handles (Stainless Steel Models Only)	<ul style="list-style-type: none"> • Soap and water • Ammonia • Stainless Steel Cleaners 	<ul style="list-style-type: none"> • Never use CHLORIDE to clean stainless steel. • Clean stainless steel front and handles with non-abrasive soapy water and a dishcloth. Rinse with clean water and a soft cloth. • Wipe stubborn spots with an ammonia-soaked paper towel, and rinse. Use a non-abrasive stainless steel cleaner. These cleaners can be purchased at most home improvement or major department stores. Always follow manufacturer's instruction. • NOTE: Always, clean, wipe and dry with grain to prevent cross-grain scratching. • Wash the rest of the cabinet with warm water and mild liquid detergent. Rinse well, and wipe dry with a clean soft cloth.

18 Warranty Information

FREEZER WARRANTY *Your freezer is protected by this warranty*

	WARRANTY PERIOD	THROUGH OUR AUTHORIZED SERVICERS, WE WILL:	THE CONSUMER WILL BE RESPONSIBLE FOR:
FULL ONE-YEAR WARRANTY	One year from original purchase date.	Pay all costs for repairing or replacing any parts of this appliance which prove to be defective in materials or workmanship. Excludes original and replacement Ice & Water filter cartridges (if equipped). Original and replacement cartridges are warranted for 30 days (parts only).	Costs of service calls that are listed under NORMAL RESPONSIBILITIES OF THE CONSUMER.*
LIMITED 2ND- 5TH YEAR WARRANTY (Cabinet Liner and Sealed System)	Second through fifth years from original purchase date.	Repair or replace any parts in the cabinet liner or sealed refrigeration system (compressor, condenser, evaporator, dryer or tubing) which prove to be defective in materials or workmanship.	Costs for pickup and delivery of the appliance required because of service. Costs for labor, parts and transportation other than with respect to the cabinet liner or Sealed Refrigeration System.
LIMITED WARRANTY (Applicable to the State of Alaska)	Time periods listed above.	All of the provisions of the full warranties above and the exclusions listed below apply.	Costs of the technician's travel to the home and any costs for pick up and delivery of the appliance required because of service.

In the U.S.A., your appliance is warranted by Electrolux Home Products, Inc. We authorize no person to change or add to any of our obligations under this warranty. Our obligations for service and parts under this warranty must be performed by us or an authorized Electrolux Home Products, Inc. servicer. In Canada, your appliance is warranted by Electrolux Canada Corp.

*NORMAL RESPONSIBILITIES OF THE CUSTOMER

This warranty applies only to products in ordinary household use, and the consumer is responsible for the items listed below:

1. Proper use of the appliance in accordance with instructions provided with the product.
2. Proper installation by an authorized servicer in accordance with instructions provided with the appliance and in accordance with all local plumbing, electrical and/or gas codes.
3. Proper connection to a grounded power supply of sufficient voltage, replacement of blown fuses, repair of loose connections or defects in house wiring.
4. Expenses for making the appliance accessible for servicing, such as removal of trim, cupboards, shelves, etc., which are not a part of the appliance when it was shipped from the factory.
5. Damages to finish after installation.
6. Replacement of light bulbs and/or fluorescent tubes (on models with these features).

EXCLUSIONS

This warranty does not cover the following:

1. CONSEQUENTIAL OR INCIDENTAL DAMAGES SUCH AS PROPERTY DAMAGE AND INCIDENTAL EXPENSES RESULTING FROM ANY BREACH OF THIS WRITTEN OR ANY IMPLIED WARRANTY.

Note: Some states do not allow the exclusion or limitation of incidental or consequential damages, so this limitation or exclusion may not apply to you.

2. Service calls which do not involve malfunction or defects in workmanship or material, or for appliances not in ordinary household use. The consumer shall pay for such service calls.
3. Damages caused by services performed by servicers other than Electrolux Home Products, Inc., Electrolux Canada Corp., or its authorized servicers; use of parts other than genuine Electrolux Home Products parts; obtained from persons other than such servicers; or external causes such as abuse, misuse, inadequate power supply or acts of God.
4. Products with original serial numbers that have been removed or altered and cannot be readily determined.

IF YOU NEED SERVICE

Keep your bill of sale, delivery slip, or some other appropriate payment record. The date on the bill establishes the warranty period should service be required. If service is performed, it is in your best interest to obtain and keep all receipts. This written warranty gives you specific legal rights. You may also have other rights that vary from state to state. Service under this warranty must be obtained by contacting Electrolux Home Products, Inc. or Electrolux Canada Corp.

This warranty only applies in the 50 States of the U.S.A. and Puerto Rico, and Canada. Product features or specifications as described or illustrated are subject to change without notice. All warranties are made by Electrolux Home Products, Inc. In Canada, your appliance is warranted by Electrolux Canada Corp.

USA

800-944-9044
Electrolux Home Products, Inc.
P.O. Box 212378
Augusta, GA 30917

Canada

866-213-9397
Electrolux Canada Corp.
6150 McLaughlin Road
Mississauga, Ontario
L5R 4C2

Solutions To Common Problems

TROUBLESHOOTING GUIDE	Before calling for service, review this list. It may save you time and expense. This list includes common occurrences that are not the result of defective workmanship or materials in this Freezer.	
PROBLEM	CAUSE	CORRECTION
FREEZER OPERATION		
Freezer does not run.	* Freezer is plugged into a circuit that has a ground fault interrupt.	* Use another circuit. If you are unsure about the outlet, have it checked by a certified technician.
	* Temperature control is in the "OFF" position.	* See " SETTING THE TEMPERATURE CONTROL " section.
	* Freezer may not be plugged in, or plug may be loose.	* Ensure plug is tightly pushed into outlet.
	* House fuse blown or tripped circuit breaker.	* Check/replace fuse with a 15 amp time delay fuse. Reset circuit breaker.
	* Power outage.	* Check house lights. Call local Electric Company.
Freezer runs too much or too long.	* Room or outside weather is hot.	* It's normal for the Freezer to work harder under these conditions.
	* Freezer has recently been disconnected for a period of time.	* It takes 24 hours for the Freezer to cool down completely.
	* Large amount of warm or hot food have been stored recently.	* Warm food will cause Freezer to run more until the desired temperature is reached.
	* Door is opened too frequently or kept open too long.	* Warm air entering the Freezer causes it to run more. Open the door less often.
	* Freezer door may be slightly open.	* See " DOOR PROBLEMS ".
	* Temperature control is set too low.	* Turn control knob to a warmer setting. Allow several hours for the temperature to stabilize.
	* Freezer gaskets are dirty, worn, cracked or poorly fitted.	* Clean or change gasket. Leaks in the door seal will cause Freezer to run longer in order to maintain desired temperature.
Interior Freezer temperature is too cold.	* Temperature control is set too low.	* Turn control knob to a warmer setting. Allow several hours for the temperature to stabilize.
Interior Freezer temperature is too warm.	* Temperature control is set too warm.	* Turn control knob to a colder setting. Allow several hours for the temperature to stabilize.
	* Door is opened too frequently or kept open too long.	* Warm air entering the Freezer causes it to run more. Open the door less often.
	* Freezer door may be slightly open.	* See " DOOR PROBLEMS ".
	* Large amount of warm or hot food have been stored recently.	* Wait until the Freezer has had a chance to reach its selected temperature.
	* Freezer has recently been disconnected for a period of time.	* Freezer requires 24 hours to cool down completely.
Freezer external surface temperature is warm.	* The external Freezer walls can be as much as 30°F warmer than room temperature.	* This is normal while the compressor works to transfer heat from inside the Freezer cabinet.
SOUND AND NOISE		
Louder sound levels whenever Freezer is on.	* Modern Freezers have increased storage capacity and more stable temperatures. They require heavy duty compressors.	* This is normal. When the surrounding noise level is low, you might hear the compressor running while it cools the interior.
Louder sound levels when compressor comes on.	* Freezer operates at higher pressures during the start of the ON cycle.	* This is normal. Sound will level off or disappear as Freezer continues to run.
Popping or cracking sound when compressor comes on.	* Metal parts undergo expansion and contraction, as in hot water pipes.	* This is normal. Sound will level off or disappear as Freezer continues to run.

PROBLEM	CAUSE	CORRECTION
SOUND AND NOISE (Cont.)		
Bubbling or gurgling sound	* Refrigerant (used to cool Freezer is circulating throughout the system.	* This is normal.
Vibrating or rattling noise.	* Freezer is not level. It rocks on the floor when it is moved slightly.	* Level the Freezer. Refer to "LEVELING" in the "FIRST STEPS" section.
	* Floor is uneven or weak.	* Ensure floor can adequately support Freezer. Level the Freezer by putting wood or metal shims under part of the Freezer.
	* Freezer is touching the wall.	* Re-level Freezer or move Freezer slightly. Refer to "LEVELING" in the "FIRST STEPS" section.
WATER / MOISTURE / FROST INSIDE FREEZER		
Moisture forms on inside Freezer walls.	* Weather is hot and humid, which increases internal rate of frost build-up.	* This is normal.
	* Door is slightly open.	* See " DOOR PROBLEMS ".
	* Door is kept open too long or is opened too frequently.	* Open the door less often.
ODOR IN FREEZER		
Odors in Freezer.	* Interior needs to be cleaned.	* Clean interior with sponge, warm water, and baking soda. Replace air filter.
	* Foods with strong odors are in the Freezer.	* Cover the food tightly.
DOOR PROBLEMS		
Door will not close.	* Freezer is not level. It rocks on the floor when it is moved slightly.	* This condition can force the cabinet out of square and misalign the door. Refer to " LEVELING " in the " FIRST STEPS " section.
	* Floor is uneven or weak.	* Ensure floor can adequately support Freezer. Level the Freezer by putting wood or metal shims under part of the Freezer.
LIGHTING PROBLEMS		
Light bulb is not on.	* The fluorescent lamp or light bulb is burned out.	* Follow directions under "INTERIOR LIGHTING" or "MID LEVEL LIGHTING" in the "Freezer FEATURES" section.
	* No electric current is reaching the Freezer.	* See "Freezer DOES NOT RUN".