

DENON

BLU-RAY DISC/DVD SURROUND RECEIVER

S-5BD

Owner's Manual

Manuel de l'Utilisateur

Manual del usuario

- The operations described in this manual are based mainly on use of the remote control unit buttons.

The same operations can also be performed using the buttons with the same names on the main unit.

- Les opérations décrites dans ce manuel reposent principalement sur l'utilisation des touches de la télécommande.

Il est également possible d'effectuer ces opérations à l'aide des touches qui portent le même nom sur l'appareil principal.

- Para realizar las operaciones que se describen en este manual se utiliza, sobre todo, el mando a distancia.

Estas operaciones se pueden realizar con los botones del mismo nombre que se encuentran en la unidad principal.

Simple Version
Version simplifiée
Versión sencilla



Basic Version
Version basique
Versión básica



Advanced Version
Version avancée
Versión avanzada



Information

"Part Names and Functions" (👉 page 62)

Informations

"Nomenclature et fonctions" (👉 page 62)

Información

"Nombres y funciones de las piezas" (👉 página 62)



SAFETY PRECAUTIONS



CAUTION

RISK OF ELECTRIC SHOCK

DO NOT OPEN



CAUTION:
TO REDUCE THE RISK OF ELECTRIC SHOCK, DO NOT REMOVE COVER (OR BACK). NO USER-SERVICEABLE PARTS INSIDE. REFER SERVICING TO QUALIFIED SERVICE PERSONNEL.

The lightning flash with arrowhead symbol, within an equilateral triangle, is intended to alert the user to the presence of uninsulated "dangerous voltage" within the product's enclosure that may be of sufficient magnitude to constitute a risk of electric shock to persons.

The exclamation point within an equilateral triangle is intended to alert the user to the presence of important operating and maintenance (servicing) instructions in the literature accompanying the appliance.

WARNING:
TO REDUCE THE RISK OF FIRE OR ELECTRIC SHOCK, DO NOT EXPOSE THIS APPLIANCE TO RAIN OR MOISTURE.

CAUTION:
USE OF CONTROLS OR ADJUSTMENTS OR PERFORMANCE OF PROCEDURES OTHER THAN THOSE SPECIFIED HEREIN MAY RESULT IN HAZARDOUS RADIATION EXPOSURE. THIS PRODUCT SHOULD NOT BE ADJUSTED OR REPAIRED BY ANYONE EXCEPT PROPERLY QUALIFIED SERVICE PERSONNEL.

Laser Class (IEC 60825-1:2001)



IMPORTANT SAFETY INSTRUCTIONS

1. Read these instructions.
2. Keep these instructions.
3. Heed all warnings.
4. Follow all instructions.
5. Do not use this apparatus near water.
6. Clean only with dry cloth.
7. Do not block any ventilation openings. Install in accordance with the manufacturer's instructions.
8. Do not install near any heat sources such as radiators, heat registers, stoves, or other apparatus (including amplifiers) that produce heat.
9. Do not defeat the safety purpose of the polarized or grounding-type plug. A polarized plug has two blades with one wider than the other. A grounding type plug has two blades and a third grounding prong. The wide blade or the third prong are provided for your safety. If the provided plug does not fit into your outlet, consult an electrician for replacement of the obsolete outlet.
10. Protect the power cord from being walked on or pinched particularly at plugs, convenience receptacles, and the point where they exit from the apparatus.
11. Only use attachments/accessories specified by the manufacturer.
12. Use only with the cart, stand, tripod, bracket, or table specified by the manufacturer, or sold with the apparatus. When a cart is used, use caution when moving the cart/apparatus combination to avoid injury from tip-over.
13. Unplug this apparatus during lightning storms or when unused for long periods of time.
14. Refer all servicing to qualified service personnel. Servicing is required when the apparatus has been damaged in any way, such as power-supply cord or plug is damaged, liquid has been spilled or objects have fallen into the apparatus, the apparatus has been exposed to rain or moisture, does not operate normally, or has been dropped.
15. Batteries shall not be exposed to excessive heat such as sunshine, fire or the like.



CAUTION:

- The ventilation should not be impeded by covering the ventilation openings with items, such as newspapers, tablecloths, curtains, etc.
- No naked flame sources, such as lighted candles, should be placed on the unit.
- Observe and follow local regulations regarding battery disposal.
- Do not expose the unit to dripping or splashing fluids.
- Do not place objects filled with liquids, such as vases, on the unit.

ATTENTION:

- La ventilación no debe quedar obstruida por haberse cubierto las aperturas con objetos como periódicos, manteles, cortinas, etc.
- Aucune flamme nue, par exemple une bougie, ne doit être placée sur l'appareil.
- Veuillez à respecter les lois en vigueur lorsque vous jetez les piles usagées.
- L'appareil ne doit pas être exposé à l'eau ou à l'humidité.
- Ne pas poser d'objet contenant du liquide, par exemple un vase, sur l'appareil.

PRECAUCIÓN:

- La ventilación no debe quedar obstruida por haberse cubierto las aperturas con objetos como periódicos, manteles, cortinas, etc.
- No debe colocarse sobre el aparato ninguna fuente inflamable sin protección, como velas encendidas.
- A la hora de deshacerse de las pilas, respete la normativa para el cuidado del medio ambiente.
- No exponer el aparato al goteo o salpicaduras cuando se utilice.
- No colocar sobre el aparato objetos llenos de líquido, como jarros.

CAUTION:

To completely disconnect this product from the mains, disconnect the plug from the wall socket outlet. The mains plug is used to completely interrupt the power supply to the unit and must be within easy access by the user.

PRECAUTION:

Pour déconnecter complètement ce produit du courant secteur, débranchez la prise de la prise murale. La prise secteur est utilisée pour couper complètement l'alimentation de l'appareil et l'utilisateur doit pouvoir y accéder facilement.

PRECAUCIÓN:

Para desconectar completamente este producto de la alimentación eléctrica, desconecte el enchufe del enchufe de la pared. El enchufe de la alimentación eléctrica se utiliza para interrumpir por completo el suministro de alimentación eléctrica a la unidad y debe de encontrarse en un lugar al que el usuario tenga fácil acceso.

FCC INFORMATION (For US customers)

1. PRODUCT

This product complies with Part 15 of the FCC Rules. Operation is subject to the following two conditions: (1) this product may not cause harmful interference, and (2) this product must accept any interference received, including interference that may cause undesired operation.

2. IMPORTANT NOTICE: DO NOT MODIFY THIS PRODUCT

This product, when installed as indicated in the instructions contained in this manual, meets FCC requirements. Modification not expressly approved by DENON may void your authority, granted by the FCC, to use the product.

3. NOTE

This product has been tested and found to comply with the limits for a Class B digital device, pursuant to Part 15 of the FCC Rules. These limits are designed to provide reasonable protection against harmful interference in a residential installation.

This product generates, uses and can radiate radio frequency energy and, if not installed and used in accordance with the instructions, may cause harmful interference to radio communications. However, there is no guarantee that interference will not occur in a particular installation. If this product does cause harmful interference to radio or television reception, which can be determined by turning the product OFF and ON, the user is encouraged to try to correct the interference by one or more of the following measures:

- Reorient or relocate the receiving antenna.
- Increase the separation between the equipment and receiver.
- Connect the product into an outlet on a circuit different from that to which the receiver is connected.
- Consult the local retailer authorized to distribute this type of product or an experienced radio/TV technician for help.

This Class B digital apparatus complies with Canadian ICES-003.
Cet appareil numérique de la classe B est conforme à la norme NMB-003 du Canada.

Copyrights / Droits d'auteur / Derechos de Autor

- It is prohibited by law to reproduce, broadcast, rent or play discs in public without the consent of the copyright holder.
- La reproduction, la diffusion, la location, le prêt ou la lecture publique de ces disques sont interdits sans le consentement du détenteur des droits d'auteur.
- De acuerdo con las leyes está prohibido reproducir, emitir, alquilar o interpretar discos en público sin la autorización del propietario de los derechos de autor.

Cautions On Installation / Précautions d'installation / Emplazamiento de la Instalación

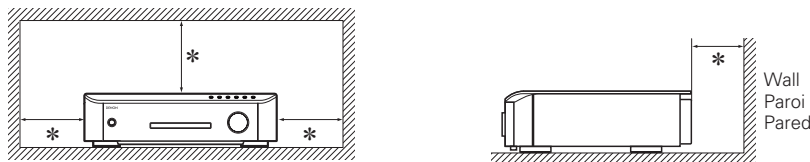

* For proper heat dispersal, do not install this unit in a confined space, such as a bookcase or similar enclosure.

- More than 20 cm (8 in.) is recommended.
- Do not place any other equipment on this unit.

* Pour permettre la dissipation de chaleur requise, n'installez pas cette unité dans un espace confiné tel qu'une bibliothèque ou un endroit similaire.

- Une distance de plus de 20 cm (8 po) est recommandée.
- Ne placez aucun matériel sur cet appareil.

* Para la dispersión del calor adecuadamente, no instale este equipo en un lugar confinado tal como una librería o unidad similar.

- Se recomienda dejar más de 20 cm (8 pulg.) alrededor.
- No coloque ningún otro equipo sobre la unidad.

NOTE ON USE / OBSERVATIONS RELATIVES A L'UTILISATION / NOTAS SOBRE EL USO

<ul style="list-style-type: none"> • Avoid high temperatures. Allow for sufficient heat dispersion when installed in a rack. • Eviter des températures élevées. Tenir compte d'une dispersion de chaleur suffisante lors de l'installation sur une étagère. • Evite altas temperaturas. Permite la suficiente dispersión del calor cuando está instalado en la consola. 	<ul style="list-style-type: none"> • Keep the unit free from moisture, water, and dust. • Protéger l'appareil contre l'humidité, l'eau et la poussière. • Mantenga el equipo libre de humedad, agua y polvo. 	<ul style="list-style-type: none"> • Do not let foreign objects into the unit. • Ne pas laisser des objets étrangers dans l'appareil. • No deje objetos extraños dentro del equipo.
<ul style="list-style-type: none"> • Unplug the power cord when not using the unit for long periods of time. • Débrancher le cordon d'alimentation lorsque l'appareil n'est pas utilisé pendant de longues périodes. • Desconecte el cordón de energía cuando no utilice el equipo por mucho tiempo. 	<ul style="list-style-type: none"> • Do not let insecticides, benzene, and thinner come in contact with the unit. • Ne pas mettre en contact des insecticides, du benzène et un diluant avec l'appareil. • No permita el contacto de insecticidas, gasolina y diluyentes con el equipo. 	<ul style="list-style-type: none"> • Never disassemble or modify the unit in any way. • Ne jamais démonter ou modifier l'appareil d'une manière ou d'une autre. • Nunca desarme o modifique el equipo de ninguna manera.
<ul style="list-style-type: none"> • Handle the power cord carefully. Hold the plug when unplugging the cord. • Manipuler le cordon d'alimentation avec précaution. Tenir la prise lors du débranchement du cordon. • Maneje el cordón de energía con cuidado. Sostenga el enchufe cuando desconecte el cordón de energía. 	<ul style="list-style-type: none"> • Do not obstruct the ventilation holes. • Ne pas obstruer les trous d'aération. • No obstruya los orificios de ventilación. 	



Getting Started

Thank you for purchasing this DENON product. To ensure proper operation, please read this owner's manual carefully before using the product. After reading them, be sure to keep them for future reference.

Contents

Getting Started	1
Accessories	1
Features	2
Cautions on Handling	2
Simple Version (Simple Setup Guide)	3
Basic Version	11
Connections	12
Connecting an HDMI-Compatible Device	12
Connecting a TV	13
Connecting a Control Dock for iPod	14
Connecting an iPod or USB Memory Device to the USB Port	14
Connecting a Set-Top Box (Satellite Tuner/Cable TV)	15
Connecting an Antenna	15
Connecting to the Network	16
Connecting an External Control Device	17
Playback (Basic)	18
About Playback Information	18
Playable Media	19
Selecting the Input Source	20
Playing Blu-ray Disc and DVD-Video	20
Playing CD	21
Playing an iPod®	22
Playing a USB Memory Device	24
Playing Files	25
Tuning in Radio Stations	27
Basic Operation	28
Surround Mode	31
Playing Back Surround Sound Using 2.0-channel or 2.1-channel Speakers	31
Surround Playback Using more than 2.1-channel Speakers	32
Advanced Version	33
Settings for Speakers Other Than 5.1-channel	34
Install	34
Connect	35
Set Up Speakers	36
Playback (Advanced)	37
Advanced Operation	37
Convenient Functions	39

Playback (Multi-zone Function) in ZONE2 (Separate Room)	41
Multi-zone Connections	41
Playback	41
How to Make Detailed Settings	42
Menu Map	42
GUI Menu Operation	43
Language Setup	44
Video Setup	44
Ratings	45
Network Setup	45
Display Setup	46
Other Setup	46
Source Select	47
Audio Adjust	48
Auto Setup	52
Manual Setup	53
Information	57
Setting Various Modes	58
Operating the Connected Devices by Remote Control Unit	59
Registering Preset Codes	59
Operating Components	59

Information	61
Part Names and Functions	62
Front Panel / Top Panel / Display	62
Rear Panel	63
Remote Control Unit	64
Inserting a Disc	65
Other Information	66
About Discs and Files	66
About Handling of Media	66
Cleaning Discs	66
About Copyright	67
AL24 Processing	67
Trademark Information	67
Surround	68
Language Code List	70
Country Code List	71
Explanation of Terms	72

Troubleshooting	74
Resetting the Microprocessor	77
Attaching the Door	77
Specifications	78

License	End of this manual
List of preset codes	End of this manual

Accessories

Check that the following parts are supplied with the product.

① Owner's manual	1
② Service station list	1
③ Power cord (Cord length: Approx. 6 ft / 1.8 m)	1
④ Remote control unit (RC-1122)	1
⑤ R6/AA batteries	2
⑥ Setup microphone (DM-A409, Cord length: Approx. 25 ft / 7.6 m)	1
⑦ AM loop antenna	1
⑧ FM indoor antenna	1
⑨ Warranty (for North America model only)	1

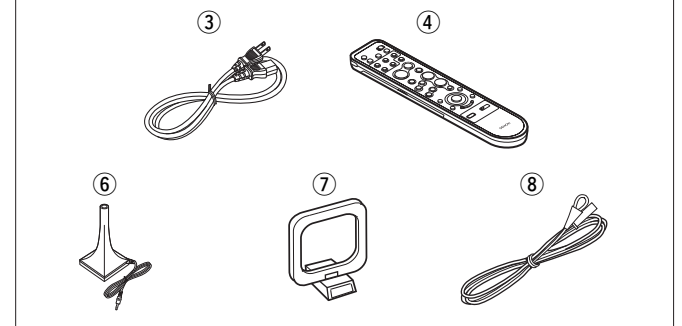

Features

Audio and video engineering design of high-end components, premium HD audio & video quality

- Support for HD audio formats and latest surround formats
- DENON's original high-end Blu-ray Disc drive mechanism for faithful reading and accurate playback of high-definition A/V signals from Blu-ray Disc
- DENON craftsmanship, in assiduous pursuit of the ideal in A/V playback devices
- DENON's pure audio technologies
- Video technologies inherited from DENON's high-end components
- Advanced DENON technologies
AL24 Processing (☞ page 67) / Restorer (☞ page 26)

Speaker Flexibility

- Drivability of full-bandwidth speakers from 4 to 16 ohms
- 2.0/2.1-channel Dynamic Play Mode (☞ page 56), to automatically assign surround channel amplifiers to the front channel amplifiers

Digital Content Friendliness

- HDMI (v. 1.4 with Audio Return Channel) (☞ page 12 "About ARC Function")
- Front inputs for iPod, USB memory player, digital camcorder via HDMI, and SD card (☞ page 12 "Connecting an HDMI-Compatible Device", ☞ page 14 "Connecting an iPod or USB Memory Device to the USB Port")
- HDMI inputs for Set-top box and video games on back panel (☞ page 12 "Connecting an HDMI-Compatible Device")
- BD-Live support (Profile 2.0) (☞ page 21)
- Network music ready
Network music can be enjoyed via the DENON Networked Control Dock. (Requires separately-sold ASD-3N/3W/51N/51W.)

Advanced GUI (Graphical User Interface)

(☞ page 43)

Enables easy, intuitive operation.

First Setup function

(☞ page 6 "Audyssey™ Auto Setup")

This unit carefully measures and analyses your room's acoustics and your speakers' characteristics to ensure the optimum acoustic settings (**Audyssey MultEQ®**) (☞ page 51).

Audyssey Dynamic Volume™ (☞ page 52) & Dynamic EQ™ (☞ page 51)

Dynamic Volume solves the problem of large variations in volume level between TV, movies and other content. Dynamic EQ solves the problem of deteriorating sound quality as volume is decreased.

One Touch Play function (☞ page 39)

The remote control unit includes a ONE TOUCH PLAY button that automatically turns on power to the TV, switches the TV's input line, and immediately starts the movie.

Automatic Sound Mode

Automatically switches to stereo sound when you're listening to a music source or to surround sound when you're enjoying video programs.

Plug 'n' Play

Starts playback immediately when an iPod or USB memory device is connected (☞ page 23 "Connect the iPod Directly to the USB Port to Play Back", ☞ page 24 "Playing a USB Memory Device").

Remote Control Unit with buttons designed for easy operation

Custom Install features

2 Source 2 Zone (☞ page 41 "Multi-zone Connections") / IR Remote in/out ports (☞ page 17 "REMOTE CONTROL Jacks") / AMX, Crestron third party serial control support with RS-232C port (☞ page 17 "RS-232C Connector") / 150mA Trigger output (☞ page 17 "TRIGGER OUT Jacks")

Cautions on Handling

• Before turning the power switch on

Check once again that all connections are correct and that there are no problems with the connection cables.

- Power is supplied to some of the circuitry even when the unit is set to the standby mode. When traveling or leaving home for long periods of time, be sure to unplug the power cord from the power outlet.

• Image persistence (image burn-in)

Do not leave the still images of the disc menu, the unit menu, etc., displayed on the TV screen for long periods. This can result in image persistence (image burn-in) on the screen.

• About Condensation

If this unit is moved from a cold place to a warm place, or installed in a room subject to rapid temperature rise from a heater, etc., condensation (dew) may form on the internal parts of the unit (operating parts and lenses).

If used in this condition, this unit will not operate correctly and damage may result. If condensation is formed on the unit, leave this unit for 1 to 2 hours with the power off before use.

• Cautions on using mobile phones

Using a mobile phone near this unit may result in noise. If so, move the mobile phone away from this unit when it is in use.

• Moving the unit

Be sure to remove a disc, turn off the power and unplug the power cord from the power outlet. Next, disconnect the connection cables to other system equipment before moving the unit.

• About Care

- Wipe the cabinet and control panel clean with a soft cloth.
- Follow the instructions when using a chemical cleaner.
- Benzene, paint thinner or other organic solvents as well as insecticide may cause material changes and discoloration if brought into contact with the unit, and should, therefore, not be used.

• Sufficiently ventilate the place of installation

If the unit is left in a room full of the smoke from cigarettes, etc., for long periods of time, the surface of the optical pickup could get dirty, in which case it will not be able to read the signals properly.

- Note that the illustrations in these instructions may differ from the actual unit for explanation purposes.

Simple Version (Simple Setup Guide)

Here, we explain the entire setup procedure, from unboxing the unit to using it in a home theater. The "Simple Version" describes the installation, connection and setup methods for 5.1-channel speakers. See page 34 for the installation, connection and setup methods for speakers other than 5.1-channel speakers.

- ❑ Before connecting the unit, turn off the power to all devices.
- ❑ For operation of the connected devices, refer to the user manuals for each device.

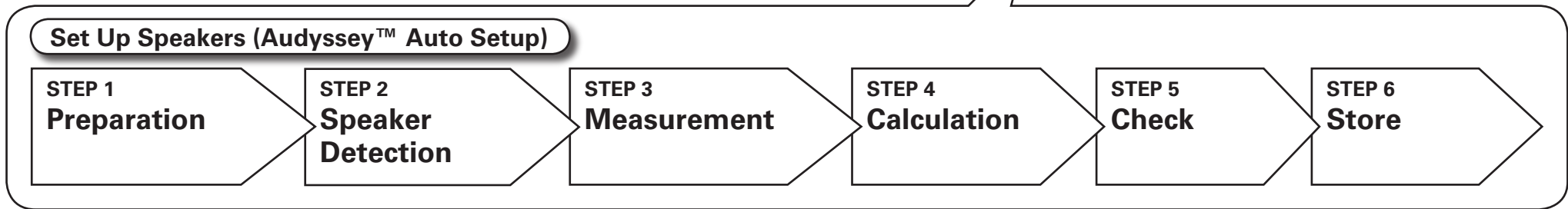
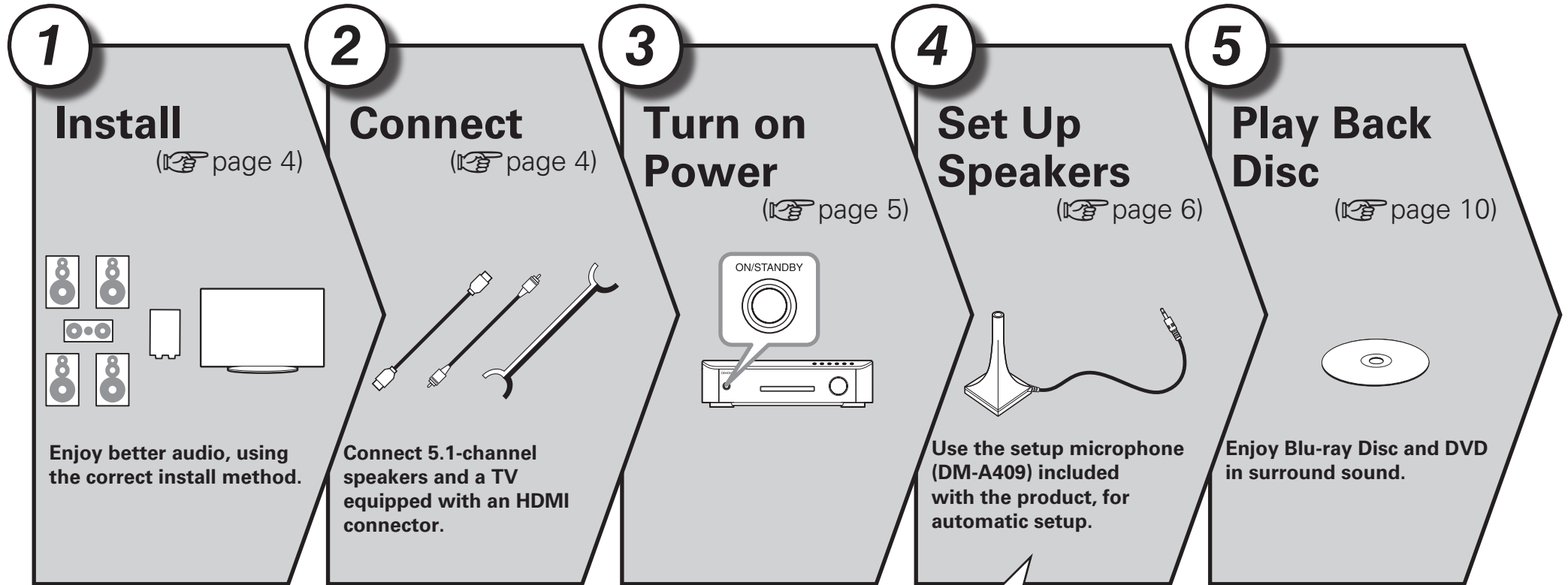

- Getting Started
- Simple Version**
- Connections
- Playback (Basic)
- Settings
- Playback (Advanced)
- Multi-zone
- GUI
- Remote Control
- Part Names
- Other Information
- Troubleshooting
- Spec.
- Index



1 Install



2 Connect



This unit can perform 2.0/2.1 to 7.1-channel surround playback. Here, we explain setup using the example of 5.1-channel speaker playback.

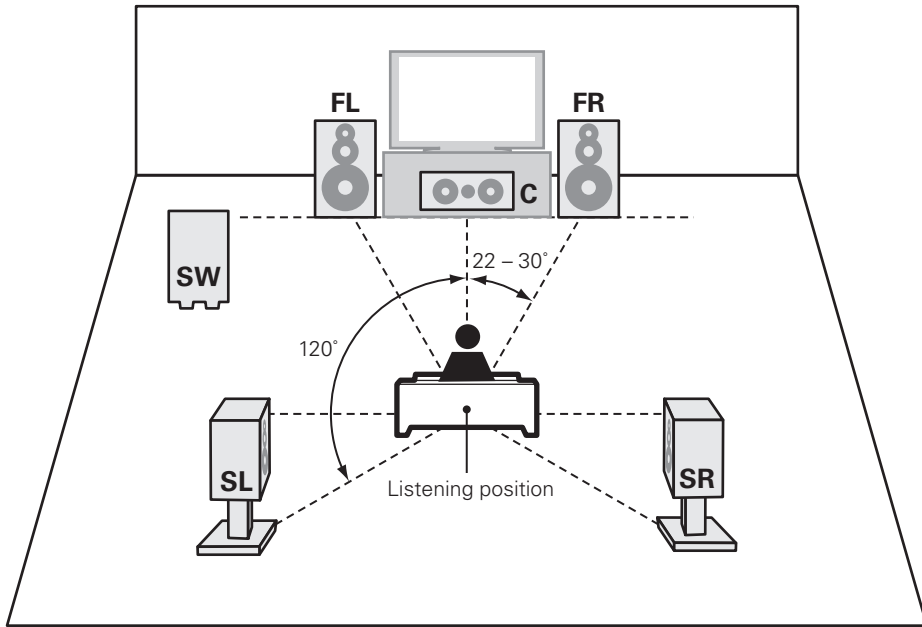

- FL** Front speaker (L)
- FR** Front speaker (R)
- C** Center speaker
- SW** Subwoofer
- SL** Surround speaker (L)
- SR** Surround speaker (R)

• Install the surround speakers in a position 2 to 3 feet/60 to 90 cm higher than ear level.

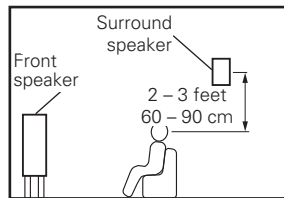

[Viewed from the side]

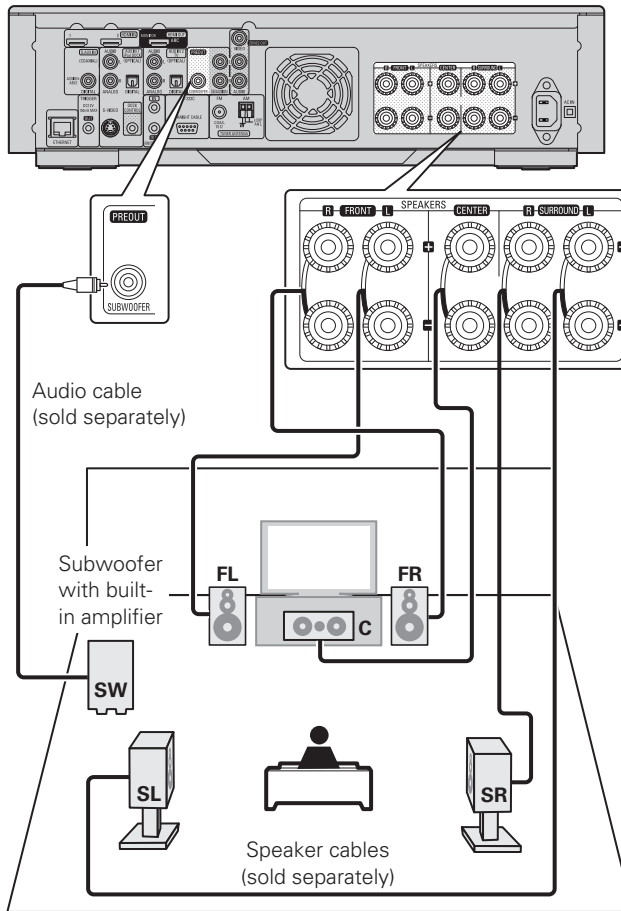

NOTE

- Connect so that the speaker cable core wires do not protrude from the speaker terminal. The protection circuit may be activated if the core wires touch the rear panel or if the + and - sides touch each other (☞ page 74 "Protection Circuit").
- Never touch the speaker terminals while the power supply is connected. Doing so could result in electric shock.

Speakers

Carefully check the left (L) and right (R) channels and + (red) and - (black) polarities on the speakers being connected to this unit, and be sure to interconnect the channels and polarities correctly.

Connecting the speaker cables

Peel off about 10 mm of sheathing from the tip of the speaker cable, then either twist the core wire tightly or terminate it.

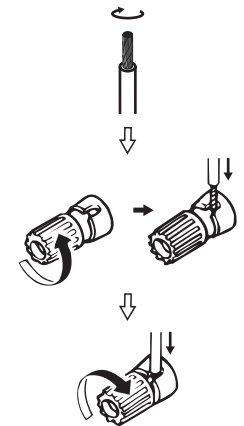

Speaker impedance

Front	4 - 16 Ω
Center	
Surround	

The "Simple Version" describes the installation, connection and setup methods for 5.1-channel speakers. See page 34 for the installation, connection and setup methods for speakers other than 5.1-channel speakers.



3 Turn on Power

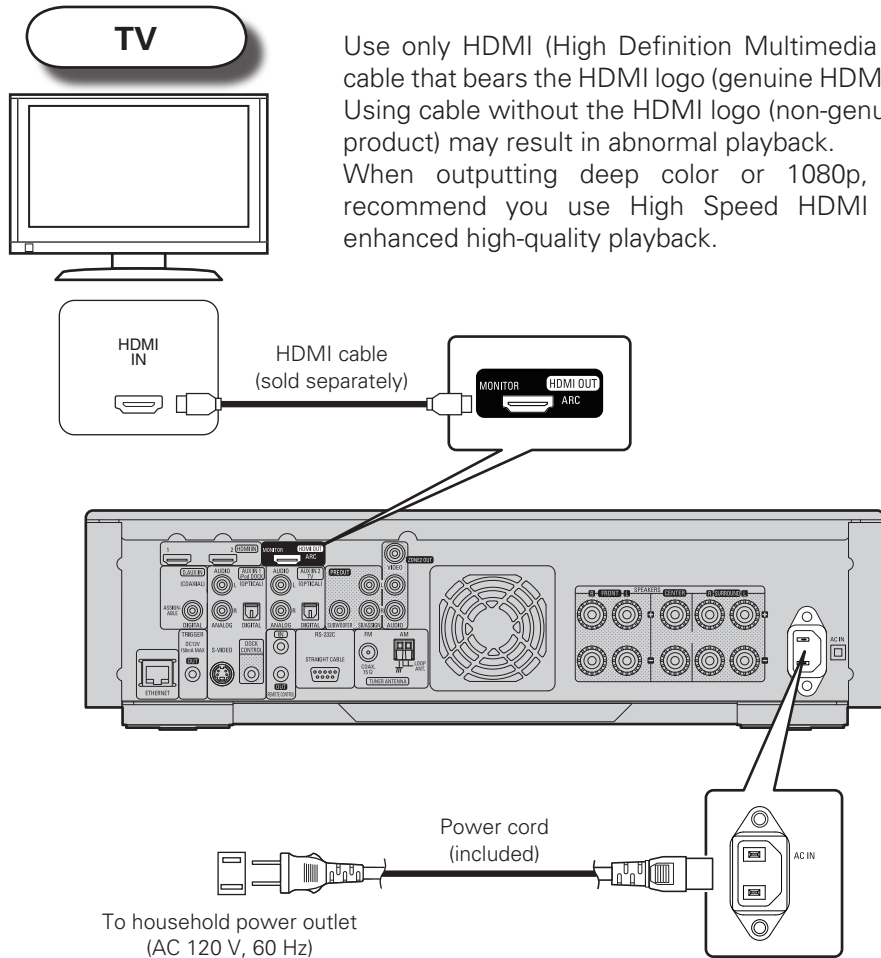

NOTE

- Do not plug in the power cord until all connections have been completed.
- Do not bundle power cords together with connection cables. Doing so can result in humming or noise.

1 Turn on the TV and subwoofer power.

Change the TV input to the input of this unit.

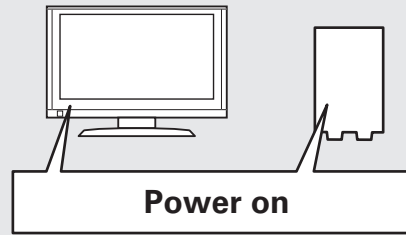

2 Press ON to turn on power to the unit.

- The power indicator lights blue.
- The "FIRST SETUP" screen is displayed on the TV.

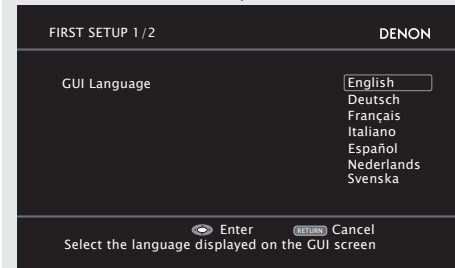
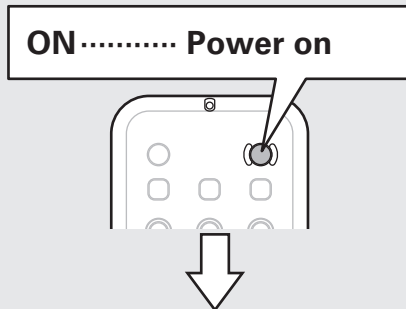

3 Select your desired language from the on-screen list and press ENTER.

The "FIRST SETUP 2/2" screen is displayed.

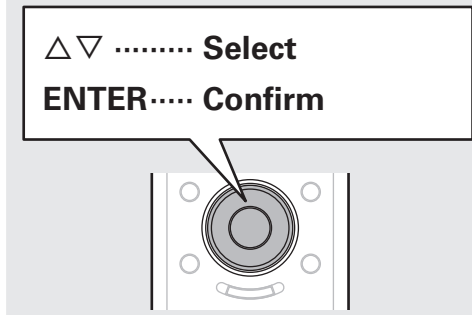

❑ If "Cancel" is Selected

"Cancel setup?" is displayed on the GUI screen. If "Yes" is selected, "FIRST SETUP" closes. The GUI Language returns to the factory setting (English).

- **Continuing with speaker setup**
See "Set Up Speakers (Audyssey™ Auto Setup)" (page 6). The title of the GUI screen will change from "FIRST SETUP" to "AUDYSSEY AUTO SETUP" at this point, but the operation method is the same.
- **Setting the GUI Language again**
Set the language using "Manual Setup" – "GUI Language" (page 57) on the GUI menu.



"FIRST SETUP" is a guide for items required for initial setup after the power is first turned on. This screen is displayed when the power is first turned on.

NOTE

The "FIRST SETUP" screen will not appear if headphones are connected.

Getting Started

Simple Version

Connections

Playback (Basic)

Settings

Playback (Advanced)

Multi-zone

GUI

Remote Control

Part Names

Other Information

Troubleshooting

Spec.

Index



4 Set Up Speakers (Audyssey™ Auto Setup)



The acoustic characteristics of the connected speakers and listening room are measured and the optimum settings are made automatically. This is called “Audyssey Auto Setup”.

To perform measurement, place the setup microphone in multiple locations all around the listening area. For best results, we recommend you measure in six positions, as shown in the illustration (up to six positions).

- When performing Audyssey Auto Setup, MultEQ®/Dynamic EQ™/Dynamic Volume™ functions become active (☞ page 51).
- To set up the speakers manually, use “Manual Setup” – “Speaker Setup” (☞ page 53) on the GUI menu.

NOTE

- Make the room as quiet as possible. Background noise can disrupt the room measurements. Close windows, silence cell phones, televisions, radios, air conditioners, fluorescent lights, home appliances, light dimmers, or other devices as measurements may be affected by these sounds.
- Cell phones should be placed away from all audio electronics during the measurement process as Radio Frequency Interference (RFI) may cause measurement disruptions (even if the cell phone is not in use).
- Do not unplug the setup microphone from the main unit until Audyssey Auto Setup is completed.
- Do not stand between the speakers and setup microphone or allow obstacles in the path while the measurements are being made. This will cause inaccurate readings.
- Loud test sounds may be played during Audyssey MultEQ automatic speaker setup. This is part of normal operation. If there is background noise in room, these test signals will increase in volume.
- Operating **VOLUME** during the measurements will cancel the measurements.
- Measurement cannot be performed when headphones are connected.

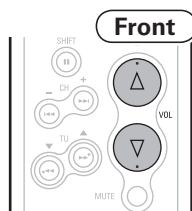

About Setup Microphone Placement

- Measurements are performed by placing the setup microphone successively at multiple positions throughout the entire listening area, as shown in **[Example ①]**. For best results, we recommend you measure in six positions, as shown in the illustration (up to six positions).
- Even if the listening environment is small as shown in **[Example ②]**, measuring at multiple points throughout the listening environment results in more effective correction.

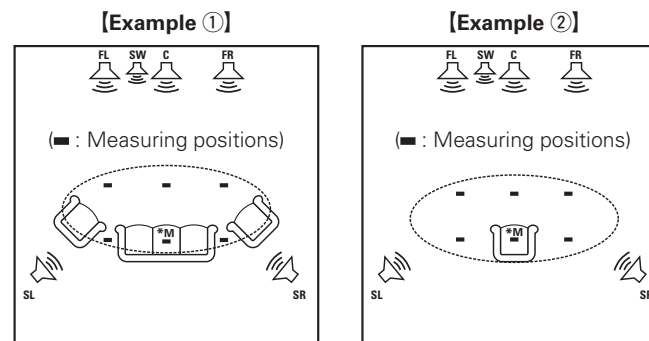

FL Front speaker (L)
FR Front speaker (R)
C Center speaker

SW Subwoofer
SL Surround speaker (L)
SR Surround speaker (R)

□ About the Main Listening Position (*M)

The main listening position is the position where listeners would normally sit or where one would normally sit alone within the listening environment. Audyssey MultEQ uses the measurements from this position to calculate speaker distance, level, polarity, and the optimum crossover value for the subwoofer.

1

Prepare the Setup Microphone

Mount the setup microphone on a tripod or stand and place it in the main listening position.

When placing the setup microphone, adjust the height of the sound receptor part to the level of the listener's ear.

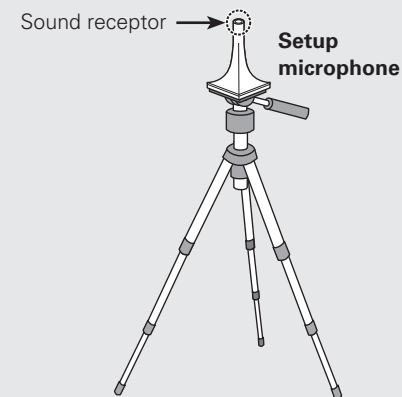

NOTE

- Do not hold the setup microphone in your hand during measurements.
- Avoid placing the setup microphone close to a seat back or wall as sound reflections may give inaccurate results.

2 Set Up the Subwoofer

If using a subwoofer capable of the following adjustments, set up the subwoofer as shown below.

- ❑ **When using a subwoofer with a direct mode**
Set the direct mode to “On” and disable the volume adjustment and crossover frequency setting.
- ❑ **When using a subwoofer without a direct mode**
Make the following settings:
 - **Volume** : “12 o'clock position”
 - **Crossover frequency** : “Maximum/Highest Frequency”
 - **Low pass filter** : “Off”
 - **Standby mode** : “Off”

3 Connect the setup microphone to the SETUP MIC jack of this unit.

❑ If “Cancel” is Selected

“Cancel setup?” is displayed on the GUI screen. If “Yes” is selected, “FIRST SETUP” closes.

• Setting up the speakers again

Repeat the operation from step 3 of **STEP1 Preparation**.

The title of the GUI screen will change from “FIRST SETUP” to “AUDYSSEY AUTO SETUP” at this point, but the operation method is the same.

STEP 1 Preparation

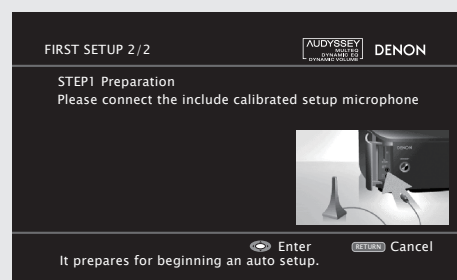

When the setup microphone is connected, the following screen is displayed.

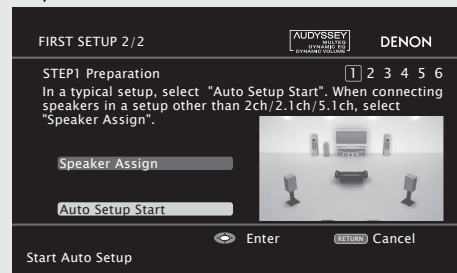

When setting up speakers other than 5.1-channel speakers, select “Speaker Assign”. When the “Speaker Assign” setup screen appears, perform the operations in Step 2 and 3 of “Set Up Speakers” (page 36).

4 Select “Auto Setup Start” and then press ENTER.

STEP 2 Speaker Detection

5 Select “Measure” and then press ENTER.

When measuring begins, a test tone is output from each speaker.
When measuring ends, the speaker detection results are displayed.

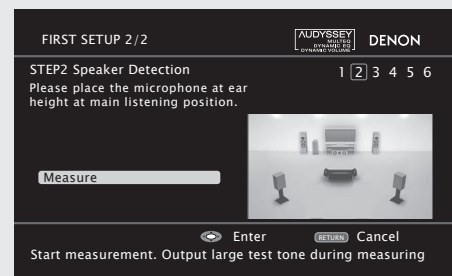

6 Select “Next → Measurement” and then press ENTER.

NOTE

If “Caution!” is displayed:

Go to “Error Messages” (page 9), check any related items, and perform the necessary procedures.

If the problem is resolved, return and restart “Audyssey Auto Setup”.

❑ When Performing Audyssey Auto Setup Over Again

Press Δ / ∇ to select “Retry”, and then press **ENTER**.

❑ When Measuring has Stopped

Press **RETURN**, and the “Cancel setup?” prompt is displayed.

Press \triangleleft / \triangleright and select “Yes”, then press **ENTER**.

STEP 3 Measurement

7 Move the setup microphone to position 2, select “Measure”, and then press ENTER.

The measurement of the second position starts. Measurements can be made in up to six positions.

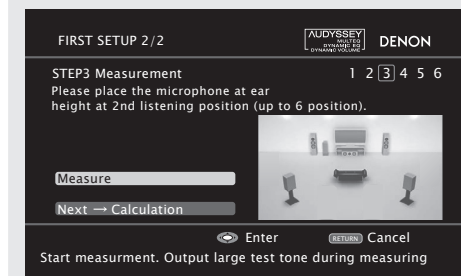

8 Repeat step 7, measuring positions 3 to 6.

When measurement of position 6 is completed, a “Measurements finished.” message is displayed.

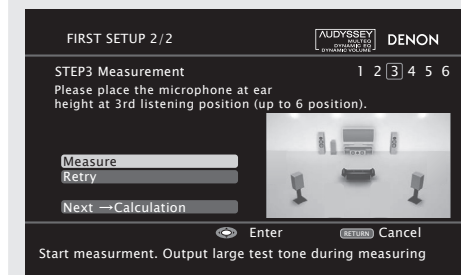

If you want to omit measurements from the next point onward, select “Next → Calculation”. (Go to page 8 **STEP4 Calculation**)

Remote control operation buttons



Move the cursor (Up/Down/Left/Right)



Confirm the setting

RETURN



Return to previous menu

Set Up Speakers (Audyssey™ Auto Setup)

STEP 4
Calculation

9 On the **STEP3** screen, select “Next → Calculation”, and then press **ENTER**.

Measuring results are analyzed, and the frequency response of each speaker in the listening room is determined.

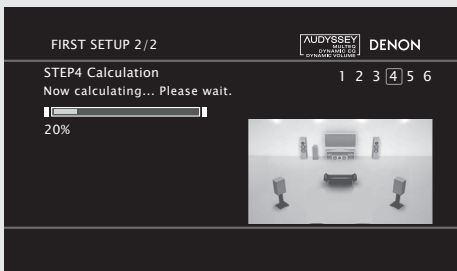

- Analysis takes several minutes to complete. The time required for this analysis depends on the number of speakers connected. The more connected speakers there are, the longer it takes to perform analysis.

STEP 5
Check

10 Select the item you want to check, and then press **ENTER**.

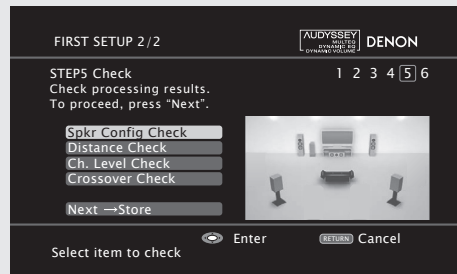

- Subwoofers may measure a greater reported distance than the actual distance due to added electrical delay common in subwoofers.
- If you want to check another item, press **RETURN**.

11 Select “Next → Store” and then press **ENTER**.

STEP 6
Store

12 Press **ENTER**.
Save the measuring results.

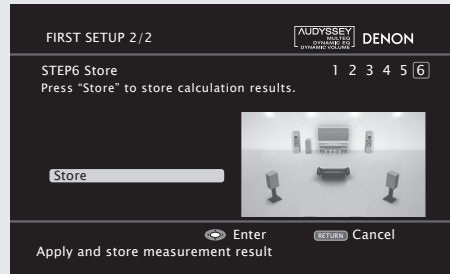

- The save operation takes about 30 seconds to complete.

NOTE

During saving of measuring results, be sure not to turn off the power.

13 When the following screen is displayed, unplug the setup microphone from the unit’s **SETUP MIC** jack.

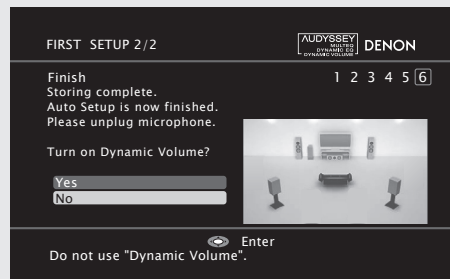

14 Set Dynamic Volume.

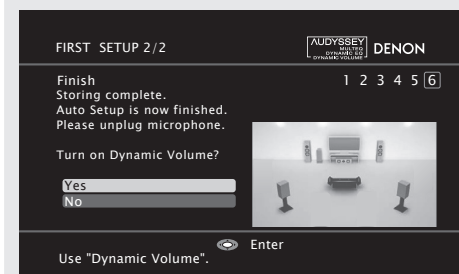

- For details of Dynamic Volume settings, see page 52.

When turning Dynamic Volume on

- Select “Yes”, and then press **ENTER**. This completes speaker setup.

When turning Dynamic Volume off

- Select “No”, and then press **ENTER**. The MultEQ default settings are displayed.
- Press **ENTER** to exit.



- For details of MultEQ settings, see page 51.

NOTE

After performing Audyssey Auto Setup, do not change the speaker connections or subwoofer volume. In event of a change, perform Audyssey Auto Setup again.



Getting Started

Simple Version

Connections

Playback (Basic)

Settings

Playback (Advanced)

Multi-zone

GUI

Remote Control

Part Names

Other Information

Troubleshooting

Spec.

Index

Error Messages

An error message is displayed if Audyssey™ Auto Setup could not be completed due to speaker placement, the measurement environment, etc. If this happens, check the relevant items, be sure to take the necessary measures, then perform Audyssey Auto Setup over again.

NOTE

Be sure to turn off the power before checking speaker connections.

Examples	Error details	Measures
<p>Caution!</p> <p>No microphone or speaker</p>	<ul style="list-style-type: none"> The connected setup microphone is broken, or a device other than the supplied setup microphone is connected. Not all speakers could be detected. The front L speaker was not properly detected. 	<ul style="list-style-type: none"> Connect the included setup microphone to the SETUP MIC jack of this unit. Check the speaker connections.
<p>Caution!</p> <p>Ambient noise is too high or Level is too low</p>	<ul style="list-style-type: none"> There is too much noise in the room for accurate measurements to be made. Speaker or subwoofer sound is too low for accurate measurements to be made. 	<ul style="list-style-type: none"> Either turn off any device generating noise or move it away. Perform again when the surroundings are quieter. Check the speaker installation and the direction in which the speakers are facing. Adjust the subwoofer's volume.
<p>Caution!</p> <p>Front R None</p>	<ul style="list-style-type: none"> The displayed speaker could not be detected. 	<ul style="list-style-type: none"> Check the connections of the displayed speaker.
<p>Caution!</p> <p>Front L Phase</p>	<ul style="list-style-type: none"> The displayed is connected with the polarities reversed. 	<ul style="list-style-type: none"> Check the polarities of the displayed speaker. For some speakers, this error message may be displayed even if the speaker is properly connected. If you are sure the connection is correct, press $\Delta \nabla$ to select "Skip", then press ENTER.

Getting Started

Simple Version

Connections

Playback (Basic)

Settings

Playback (Advanced)

Multi-zone

GUI

Remote Control

Part Names

Other Information

Troubleshooting

Spec.

Index



5 Play Back Disc

1 Insert a disc.
 • Press on the main unit to open/close the disc tray.

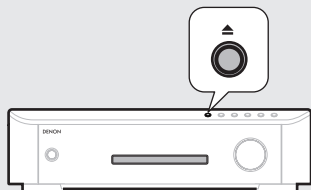

• Insert the disc with the side you want to play facing down.

2 Make the various settings for playback on the disc menu.

..... Select
ENTER Confirm



• You can make the following settings on the disc menu. (Settable items vary depending on the disc.)

- Subtitle language
- Audio language
- Audio format etc.

• During playback, press **TOP MENU** or **POPUP/MENU** to display the menu.

If the menu continues, press to get to the next part.

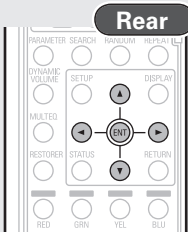
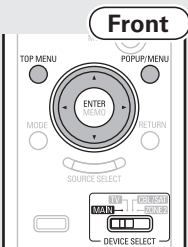

3 Select the playback title or chapter from the top menu for playback.

..... Select
ENTER Playback

NOTE

When playing back a high-quality signal such as Dolby TrueHD, Dolby Digital Plus, or DTS-HD, set the “BD Audio Mode” (page 58) to “HD Audio Output”.

OFF Standby

..... Playback

..... Stop

..... Pause/Still

..... Forward-Skip

..... Reverse-Skip

..... Forward-Search

..... Reverse-Search

..... Volume up

..... Volume down

MUTE Muting

When Power is Switched to Standby

Press **OFF**.

[Power indicator status in standby mode]

- Normal standby : Off
- When “HDMI Control” is set to “ON” : Red
- When “Quick Start Mode” is set to “ON” : Red

NOTE

During power standby, a slight amount of power is consumed. To totally cut off the power, remove the power cord from the power outlet.

ONE TOUCH PLAY

Turns on this unit and the TV, and disc playback starts automatically.

To use this function you need to set up this unit in advance. For details of setup, see the following items.

- “One Touch Play Function” (page 39)
- “HDMI Control Function” (page 39)

Other operations

- Random Playback** (page 29)
- Repeat Playback** (page 29)
- Switching Audio** (page 30)
- Switching the Angle** (page 30)
- Changing the Subtitles and Subtitle Style** (page 31)
- Surround Mode** (page 31)
- Looking for Specific Sections Using the Search Modes** (page 37)
- Setting Locations to Play Back Again (Marker Function)** (page 38)

Basic Version

Here, we explain the connections and basic operation methods for this unit.

- Connections
- Playback (Basic Operation/Surround Mode)

☐ Refer to the pages indicated below for information on connecting and playing back the various media and external devices.

Audio and Video	Connection	Playback
Blu-ray Disc	–	☞ page 20
DVD-Video	–	☞ page 20
CD	–	☞ page 21, 25
Set-Top Box (Satellite Tuner or Cable TV)	☞ page 12, 15	–
Digital Camcorder	☞ page 12	–
Game Device	☞ page 12	–
Control Dock for iPod	☞ page 14	☞ page 22
BD-LIVE	☞ page 16	–
Audio		
TV Audio	☞ page 13	–
iPod®	☞ page 14	☞ page 23
USB Memory Device	☞ page 14	☞ page 24
SD Memory Card	☞ page 62	☞ page 25
Radio	☞ page 15	☞ page 27
Others		
Update the Unit Software	☞ page 16	☞ page 46
External Control Device	☞ page 17	–

For speaker and TV connections, see page 4, 5.

Connections

- Connect this unit as follows before using. Make connections according to the equipment you are connecting.
- Some settings of this unit may be necessary depending on the connection method. Check each connection item for more information.
- Select the cables (sold separately) according to the components being connected.

NOTE

- Do not plug in the power cord until all connections have been completed.
- When making connections, also refer to the operating instructions of the other components being connected.
- Be sure to connect the left and right channels properly (left with left, right with right).
- Do not bundle power cords together with connection cables. Doing so can result in noise.

Connecting an HDMI-Compatible Device

You can connect up to three HDMI-compatible devices to the unit.

▣ Cables Used for Connections

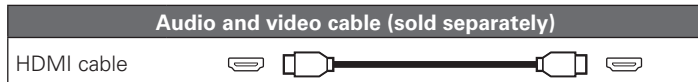

- This interface allows transfer of digital video signals and digital audio signals over a single HDMI cable.

▣ About HDMI Cables

- Use a cable on which the HDMI logo is indicated (a certified HDMI product) for connection to the HDMI connector. Normal playback may not be possible when using a cable other than one on which the HDMI logo is indicated (a non-HDMI-certified product).
- When a device supporting Deep Color signal transfer is connected, use a cable compatible with HDMI version 1.3a.
- When outputting Deep Color or 1080p, etc., we recommend you use High Speed HDMI cable for enhanced high-quality playback.
- This unit supports “Deep Color” and “x.v.Color”. For details about “Deep Color” and “x.v.Color”, see page 72, 74.

Copyright protection system

In order to play back digital video and audio such as BD-Video or DVD-Video via HDMI connection, both this unit and TV need to support the copyright protection system known as HDCP (High-bandwidth Digital Content Protection System). HDCP is copyright protection technology comprised of data encryption and authentication of the connected AV device. This unit supports HDCP.

- If a device that does not support HDCP is connected, video and audio are not output correctly. Read the owner’s manual of your television for more information.

▣ About ARC (Audio Return Channel) Function

The Audio Return Channel in HDMI 1.4 enables a TV, via a single HDMI cable, to send audio data “upstream” to this unit, increasing user flexibility and eliminating the need for any separate S/PDIF audio connection.



- To enable the ARC function, set “HDMI Control” to “ON” (page 55).
- Connect using a cable compatible with HDMI 1.4.

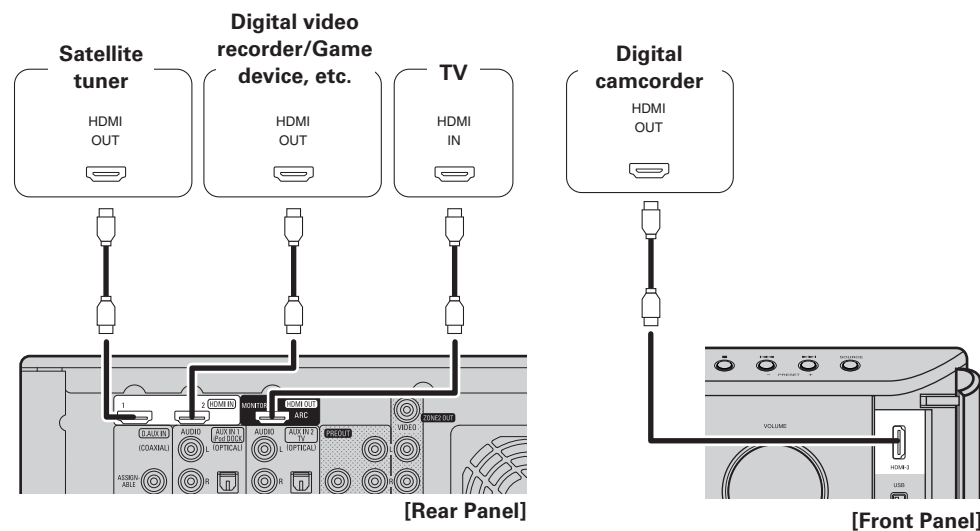

By connecting to a device with an HDMI control function, you can use the unit to operate an external device, or use an external device to operate the unit (page 39 “HDMI Control Function”).

NOTE

- If the GUI menu “HDMI Audio Out” setting (page 55) is set to “Amp”, the sound may be interrupted when the TV’s power is turned off.
- Audio signal input may not be supported depending on the HDMI compatible TV (projector, etc.) being used. When this unit is connected to this kind of device, audio signals are not output from the HDMI connector.

Required Settings for HDMI Connection

Settings can only be made when the input source is "BD/SD".
Set as necessary. For details, see the respective reference pages.

Make the Video Output Signal Setting for the Connected Television

"Video Setup" (page 44)

About HDMI Video Resolution Setting

- Change the HDMI video resolution by pressing **RESOLUTION**. Switch the output mode as follows. (Default settings are underlined.)

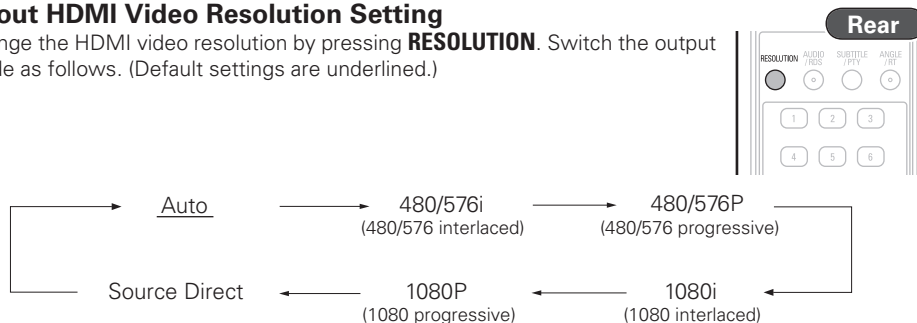

- If the HDMI resolution is not set to "Auto", set it to correspond with the resolution of your television.

NOTE

When ZONE2 is powered on, the HDMI video resolution in the MAIN ZONE switches automatically according to the input signal. When this happens, it is not possible to switch to a different video resolution, even by pressing **RESOLUTION**. (See page 41 for information on ZONE2).

Connecting a TV

- You can listen to TV audio only.
- Select the terminal to use and connect the device.
- For instructions on HDMI connections, see "Connecting an HDMI-Compatible Device" on page 12.



This connection is not required when a TV compatible with the ARC function (Audio Return Channel (HDMI1.4 standard function)) is connected to this unit via an HDMI connection.
For details, see "About ARC (Audio Return Channel) Function" (page 12) or refer to the instruction manual for your TV.

Cables Used for Connections

Audio cables (sold separately)	
Audio cable	(White) (Red)
Coaxial digital cable	(Orange)
Optical cable	

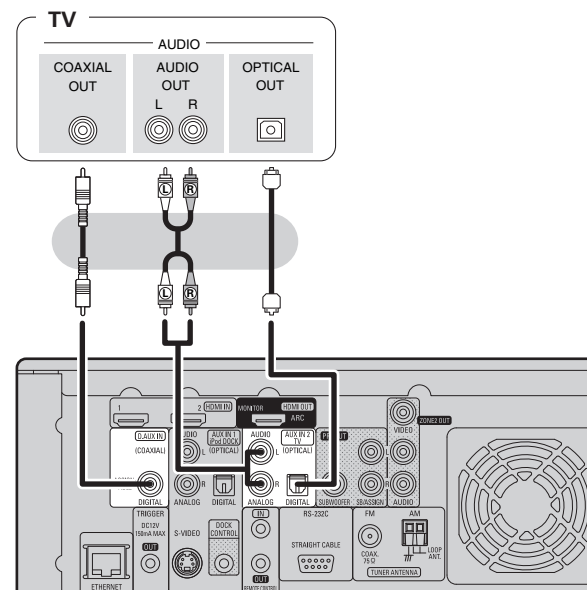

When using a coaxial digital cable for the digital audio connection, set "Manual Setup" – "Audio Setup" – "COAX Input Assign" on the GUI menu (page 56) to "AUX2".

- Getting Started
- Simple Version
- Connections
- Playback (Basic)
- Settings
- Playback (Advanced)
- Multi-zone
- GUI
- Remote Control
- Part Names
- Other Information
- Troubleshooting
- Spec.
- Index

Connecting a Control Dock for iPod

- Connect the Control Dock for iPod to the unit to enjoy video and music stored on an iPod.
- For the Control Dock for iPod, use ASD-11R/3N/3W/51N/51W made by DENON (sold separately).
- For instructions on the control dock for iPod settings, refer to the control dock for iPod's operating instructions.

▣ Cables Used for Connections

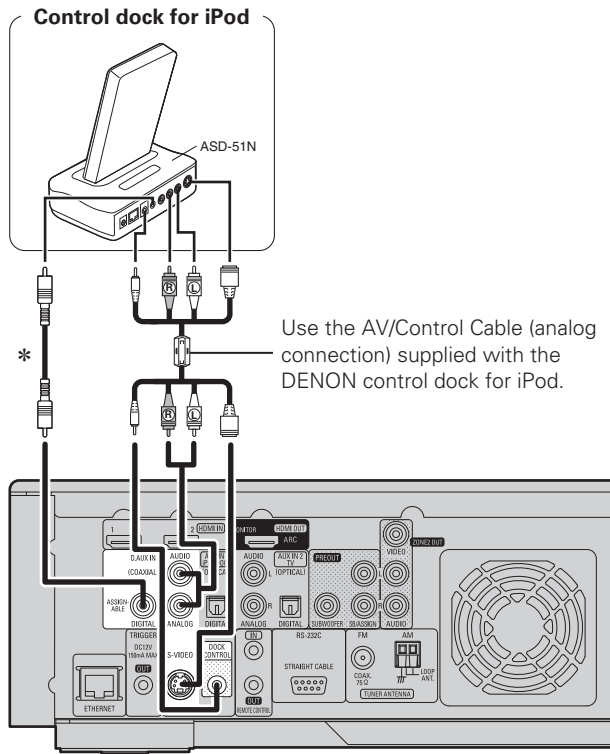
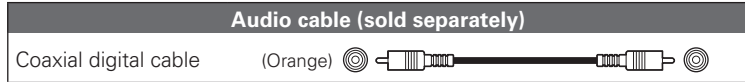

* When connecting to the Digital audio output connector of ASD-51N / 51W, set "Manual Setup" – "Audio Setup" – "COAX Input Assign" (page 56) on the GUI menu to "AUX1".



You can also connect the iPod you are using directly to the USB port of this unit (page 14 "Connecting an iPod or USB Memory Device to the USB Port").

Connecting an iPod or USB Memory Device to the USB Port

When you connect an iPod or USB memory device to the USB port, you can enjoy music, stored on the iPod or USB memory device.

▣ Cables Used for Connections

To connect an iPod to this unit, use the USB cable supplied with the iPod.

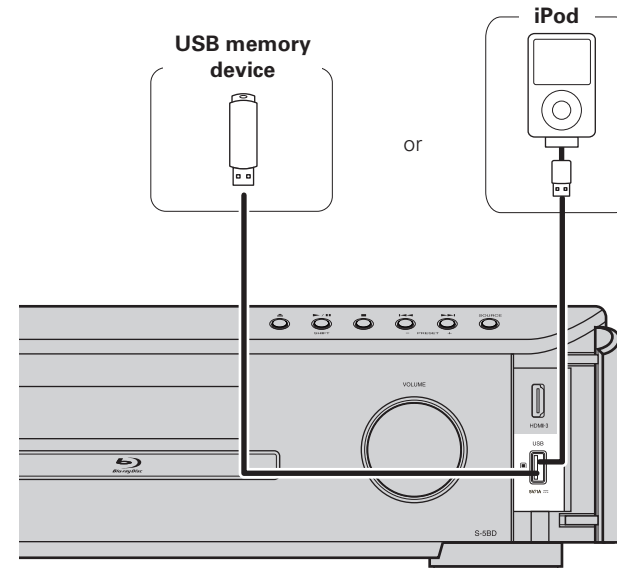

- When you want to playback a video file stored on an iPod, use the DENON control dock for iPod (ASD-11R/3N/3W/51N/51W, sold separately) (page 14 "Connecting a Control Dock for iPod").
- This unit supports audio playback from the iPod (fifth generation or later), iPod nano, iPod classic, and iPod touch (it is not compatible with iPod shuffle). For details, check the Web.
- DENON does not guarantee that all USB memory devices will operate or receive power. When using a portable USB connection type HDD of the kind to which an AC adapter can be connected to supply power, use the AC adapter.

NOTE

- USB memory devices will not work via a USB hub.
- It is not possible to connect and use a computer via the USB port of this unit using a USB cable.

Connecting to the Network

- You can use a disc which offers BD-LIVE function by connecting the unit to the Internet (☞ page 21).
- You can update by downloading the latest firmware from the DENON website.
For more information, on the GUI menu, select "Other Setup" – "Firmware Update" (☞ page 46).
- See "Network Setup" on the GUI menu (☞ page 45) for more information on network setting.

❑ Cables Used for Connections

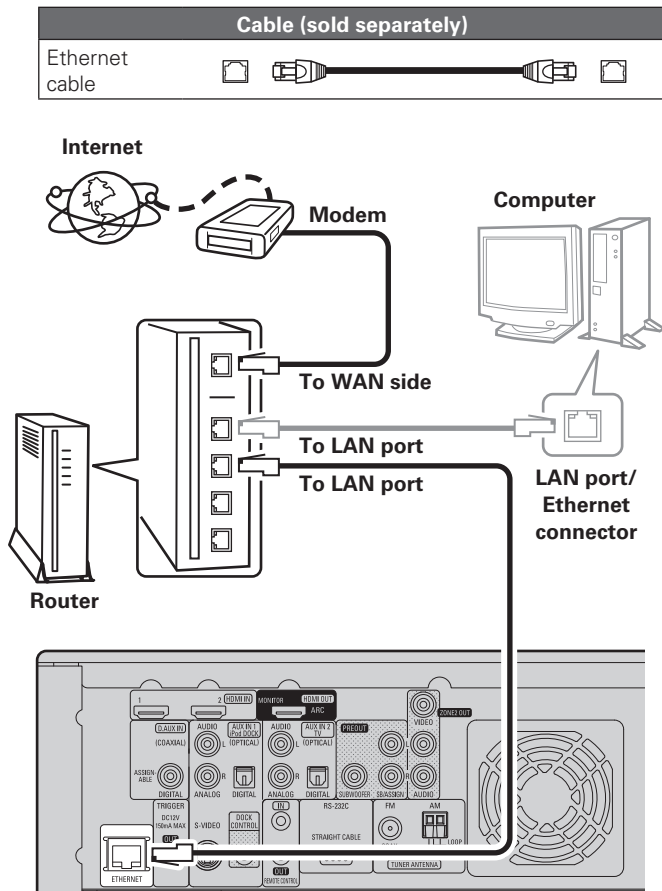

For connections to the Internet, contact an ISP (Internet Service Provider) or a computer shop.

Required system

❑ Broadband Internet Connection

❑ Modem

Device that connects to the broadband circuit and conducts communications on the Internet.

A type that is integrated with a router is also available.

❑ Router

When using this unit, we recommend you use a router equipped with the following functions:

- Built-in DHCP server
This function automatically assigns IP addresses on the LAN.
- Built-in 100BASE-TX switch
When connecting multiple devices, we recommend a switching hub with a speed of 100 Mbps or greater.

❑ Ethernet Cable (CAT-5 or Greater Recommended)

- Use for wired LAN.
- Use only shielded STP or ScTP LAN cable which is available at retailer.
- Some flat type Ethernet cables are easily affected by noise.
We recommend using a normal type cable.



- If you have an Internet provider contract for a line on which network settings are made manually, make the settings at "Network Setup" (☞ page 45).
- With this unit, it is possible to use the DHCP and Auto IP functions to make the network settings automatically.
- When using this unit with the broadband router's DHCP function enabled, this unit automatically performs the IP address setting and other settings.
When using this unit connected to a network with no DHCP function, make the settings for the IP address, etc., at "Network Setup" (☞ page 45).
- When setting manually, check the setting contents with the network administrator.

NOTE

- A contract with an ISP is required to connect to the Internet.
No additional contract is needed if you already have a broadband connection to the Internet.
- The types of routers that can be used depend on the ISP. Contact an ISP or a computer shop for details.
- DENON assumes no responsibility whatsoever for any communication errors or troubles resulting from customer's network environment or connected devices.
- This unit is not compatible with PPPoE. A PPPoE-compatible router is required if you have a contract for a type of line set by PPPoE.
- Do not connect an ETHERNET connector directly to the LAN port/Ethernet connector on your computer.

Connecting an External Control Device

REMOTE CONTROL Jacks

If this unit is installed in a location that is out of range of the signal from the remote control unit, you can still operate the unit and the devices connected to it by using a commercially available IR receiver. You can also use it to remotely control ZONE2 (another room).

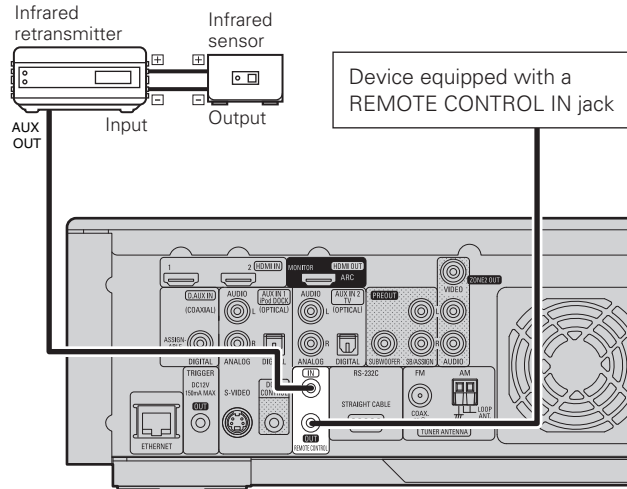

RS-232C Connector

By connecting an external serial controller, you can control all sorts of household electrical devices (including lights, electric curtains, and air conditioning units) in addition to your audio and video devices.

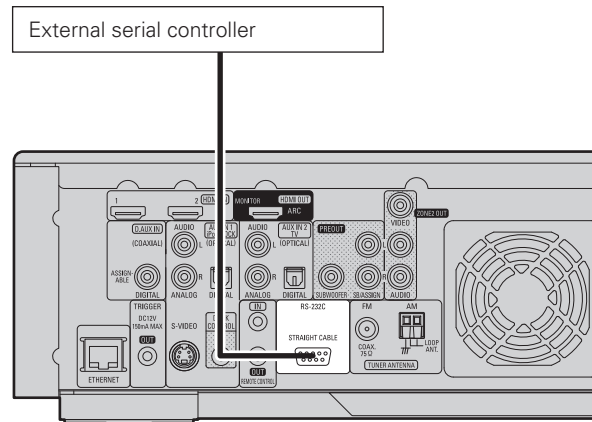

TRIGGER OUT Jacks

When a device with TRIGGER IN jack is connected, the connected device's power on/standby can be controlled through linked operation to this unit. The TRIGGER OUT jack outputs a maximum 12 V/150 mA electrical signal.

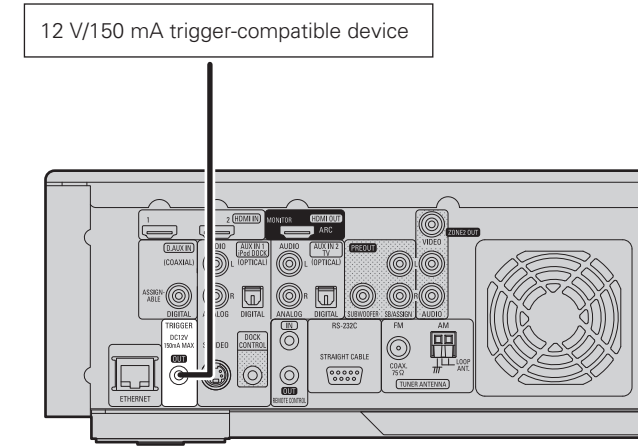

Set to change the conditions for linked operation via the TRIGGER OUT jack.

“Trigger Out” (page 56)

NOTE

If the permissible trigger input level for the connected device is larger than 12V/150mA, or has shorted, the TRIGGER OUT jack cannot be used. In this case, turn off the power to the unit, and disconnect it.

- Getting Started
- Simple Version
- Connections
- Playback (Basic)
- Settings
- Playback (Advanced)
- Multi-zone
- GUI
- Remote Control
- Part Names
- Other Information
- Troubleshooting
- Spec.
- Index

Playback (Basic)

- ❑ About Playback Information (👉 page 18)
- ❑ Playable Media (👉 page 19)
- ❑ Selecting the Input Source (👉 page 20)

- ❑ Playing Blu-ray Disc and DVD-Video (👉 page 20)
- ❑ Playing CD (👉 page 21)
- ❑ Playing an iPod® (👉 page 22)
- ❑ Playing a USB Memory Device (👉 page 24)
- ❑ Playing Files (👉 page 25)
- ❑ Tuning in Radio Stations (👉 page 27)

❑ Basic Operation (👉 page 28)

Surround Mode (👉 page 31)

Playback (Advanced) (👉 page 37)

About Playback Information

Displays playback information on the information bar and media player screen.

Press DISPLAY.

Each time the button is pressed, it switches to the next playback information.

- To erase display, press **DISPLAY** until it goes away.

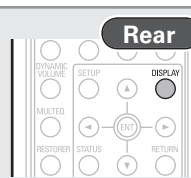

Displayed content differs depending on the media being played back. Also, the information displayed during playback and stop differs.

Information Bar Display

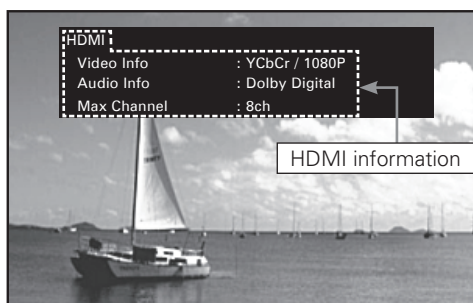
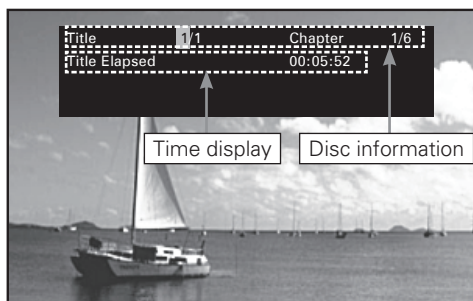

NOTE

- The (prohibited mark) may appear on the top right of the TV screen during an operation. This means that the operation being conducted is prohibited.
- Depending on the disc, certain operations may not be as described in this manual. Check each disc owner's manual for more information.
- During playback of a 2-layered disc, pictures may stop momentarily. This happens when the first layer switches to the second layer. This is not a malfunction.

Search Using Information Bar

In the orange color cursor area, when you enter the number that you wish to search, that location is searched. There are 2 search modes, "Title search" and "Chapter search".

- 1** Use $\Delta \nabla \triangleleft \triangleright$ to move the cursor to the item that you wish to search.
- 2** Use 0 – 9 and +10 to enter a value.
- 3** Press **ENTER**.
Search is executed and playback begins.

- If the input number information is not on the disc, the current playback display reappears.



Media Player Display

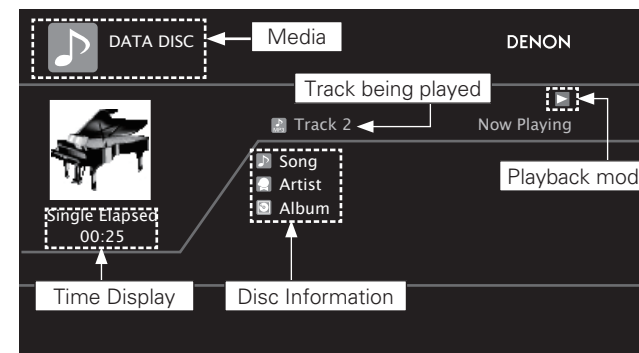

Playable Media

Discs

Playable discs	Playable formats/modes	Playable region codes	Category type
BD-Video *1, *2		Include region 	
DVD-Video *1, *2		Include region 	
DVD-R, DVD+R		Video mode, AVCHD format	
DVD-RW, DVD+RW	 		
CD		-	
CD-R			
CD-RW			

- *1 BD-Video/DVD-Video discs may not operate as described in this manual due to menu structure.
- *2 The Blu-ray Disc player and BD-Video disc, and DVD player and DVD-Video disc each have their region codes (code assigned for each region). Playback is not possible if the codes do not match.

The following discs will not play back on this unit.

- BD-RE Ver1.0 (BD disc with cartridge)
- BD-ROM/BD-R/BD-RE discs containing recorded movie, still image, audio, etc., files
- BD-R/BD-RE in which BDMV/BD-RE is recorded
- HD DVD / DVD-RAM / DVD-Audio
- CDV (Only the audio part can be played)
- CD-G (Only the audio signals can be output)
- Non-standard CD (CD with copy protection, etc.)
- Unauthorised disc (Pirated disc)
- Disc with recording area less than 55 mm in diameter
- Video Single Disc (VSD) / CVD / Video CD / Super Video CD / Compact Disc-Interactive (CD-I) / Photo CDs / Super Audio CD

NOTE

- A disc may not be accessible or play back incorrectly due to audio and video interruptions, etc., depending on the recording conditions when recorded with a Blu-ray Disc recorder or DVD recorder.
- Unfinalised DVD-R/-RW/+R/+RW, and CD-R/-RW discs may not play back. Finalise discs before playing.

Files

Playable files (Extension)	File specification	Category type
 MP3 (.mp3)	<ul style="list-style-type: none"> • Sampling frequency: 44.1 kHz, 48 kHz • Bit rate: 64 kbps – 320 kbps (144 kbps non-compatible) • Audio type: MPEG 1 Audio Layer 3 	
 WMA (.wma) *	<ul style="list-style-type: none"> • Sampling frequency: 44.1 kHz, 48 kHz • Bit rate: 48 kbps – 192 kbps • Audio type: WMA Version 9 	
 AAC (.m4a) *	<ul style="list-style-type: none"> • Sampling frequency: 44.1 kHz, 48 kHz • Bit rate: 64 kbps – 192 kbps (Variable Bit Rate non compatible) • Audio type: AAC 	
 LPCM (.wav)	<ul style="list-style-type: none"> • Sampling frequency: 44.1 kHz, 48 kHz • Bit length: 16 bit • Number of channels: 2 ch 	
 JPEG (.jpg/.jpeg)	<ul style="list-style-type: none"> • Maximum resolution: 4,096 x 4,096 pixels • Minimum resolution: 32 x 32 pixels • Maximum file size: 12 MB 	

* This unit cannot play back files recorded under DRM (Digital Rights Management).

NOTE

- The abovementioned file type may also fail to play back depending on conditions at the time of recording.
- If characters not supported on the menu screen are included in a file name, title, artist name or album title, those are not displayed correctly.
- JPEG format images stored in progressive format cannot be played back.

SD Memory Cards

Playable cards	Playable files	Category type
SD memory card (8 MB – 2 GB)	 • Data recorded for BD BONUS VIEW or BD-LIVE use.	
SDHC memory card *1 (4 GB)		
miniSD card *2 (8 MB – 2 GB)		
microSD card *2 (8 MB – 2 GB)		

*1 This unit supports SD memory card with FAT16 file system, and SDHC memory card with FAT32 file system.

*2 For miniSD card and microSD card adapter is necessary.



NOTE

- This unit is not compatible with the miniSDHC card or microSDHC card.
- Insert or remove a SD memory card while the power is in standby. If you insert a SD memory card while the power is ON, the SD memory card may not be read.

USB Memory Devices

Standard	Playable files	Category type
USB Mass Storage Class *		

* This unit is compatible with USB memory devices in "FAT16" or "FAT32" format.

The icons show the category of content applicable to each operation.



Selecting the Input Source

Press the input source select button (BD/SD, HDMI, TUNER, USB, AUX) to be played back.

The desired input source can be selected directly.

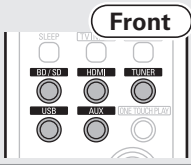

You can also use the following operation to select an input source.

Using the "Source Select" Menu

- 1 Press **SOURCE SELECT**.
Display the "SOURCE SELECT" menu.

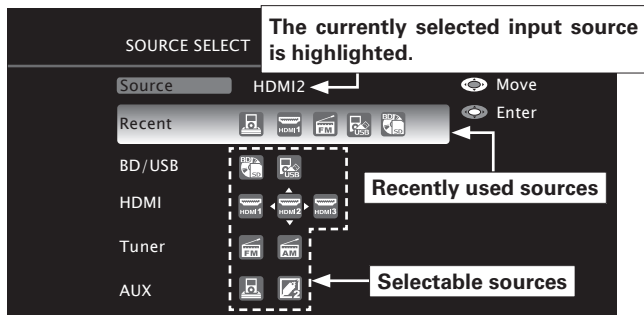

- 2 Use $\Delta \nabla \triangleleft \triangleright$ to select the input source icon, then press **ENTER**.
The input source is set and the source selection menu is turned off.

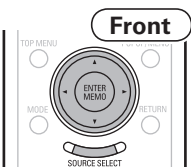

- is displayed when using a Control dock for iPod.
- When using with an iPod connected directly to the USB port of this unit, select "USB" for the input source.
- To turn off the source selection menu without selecting an input source, press **SOURCE SELECT** again.

Using the Button on the Main Unit

Press **SOURCE**.
Each time the button is pressed, it switches to the next input source.

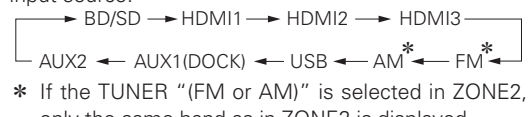

* If the TUNER "(FM or AM)" is selected in ZONE2, only the same band as in ZONE2 is displayed.

Playing Blu-ray Disc and DVD-Video



- 1 Prepare for playback.
 - 1 Turn on the TV and subwoofer power.
 - 2 Change the TV input to the input of this unit.

- 2 Press **ON** to turn on power to the unit.

- 3 Insert a disc.
 - Press \blacktriangle on the main unit to open/close the disc tray.

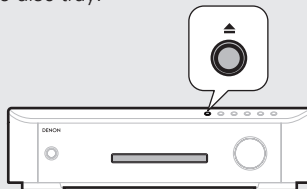

- When the disc tray opens, the input source automatically switches to "BD/SD" and the unit enters "Disc Mode".
- If a disc is already inserted in the disc tray, switch to "Disc Mode" by selecting **BD/SD**.

- 4 Make the various settings for playback on the disc menu.

$\Delta \nabla \triangleleft \triangleright$ Select
ENTER Confirm

- You can make the following settings on the disc menu. (Settable items vary depending on the disc.)
 - Subtitle language
 - Audio language
 - Audio format etc.
- During DVD-Video playback, press **TOP MENU** or **POPUP/MENU** to display the menu. If the menu continues, press $\Delta \nabla \triangleleft \triangleright$ to get to the next part.

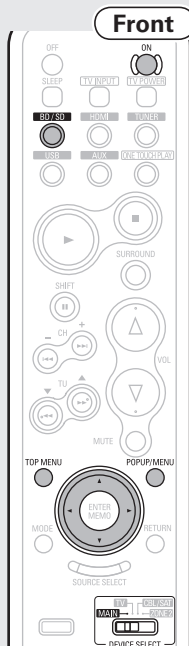

- 5 Press $\Delta \nabla \triangleleft \triangleright$ in the Top Menu screen to select the title or chapter.

- If you use **1 - 9, +10** to select the chapter or title, you can start playback.



With Blu-ray Disc, depending on the disc, you can select title and chapter from the popup menu.

- 6 Press **ENTER**.
Playback starts.

- Adjusting the Master Volume** (page 28)
Press **VOL $\blacktriangle \blacktriangledown$** .
- Stop Playback (Resume Function)** (page 28)
Press **■**.
- Pause Playback** (page 28)
Press **II**.
- Step-by-Step Playback** (page 28)
During pause, press **II**.
- Fast Forward/Fast Reverse Playback** (page 29)
During playback, press **⏩ ⏪**.
- Slow Forward/Slow Reverse Playback** (page 29)
During pause, press **⏩ ⏪**.
- Skipping to the Chapter** (page 29)
During playback, press **⏮ ⏭** or $\Delta \nabla$.
- Repeat Playback** (page 29)
Press **REPEAT**.
- Switching Audio** (page 30)
During playback of a Primary Audio/Secondary Audio title, press **AUDIO/RDS**.

NOTE

When playing back a high-quality signal such as Dolby TrueHD, Dolby Digital Plus, or DTS-HD, set the "BD Audio Mode" (page 58) to "HD Audio Output".



Playing Blu-ray Disc and DVD-Video

Enjoying BD-LIVE Features

While playing back a disc compatible with BD-LIVE, you can connect to the BD-LIVE site for Blu-ray Discs via the Internet and display special features and caption information not available on the disc.

- The functions that can be used with BD-LIVE differ from disc to disc.
- For details on the functions and how to operate them, see the individual disc's on-screen displays and explanations.
- To play back a BD-LIVE-compatible Blu-ray Disc, you should first install an SD memory card in this unit.



- To use BD-LIVE functions, connect this unit to the Internet and make the settings described below, as necessary:

Connections : "Connecting to the Network" (page 16)

Settings : "Network Setup" (page 45)

- Depending on your network environment, in some cases time may be required to connect to the network or connection may not be possible.

NOTE

Do not remove the SD memory card from this unit while playing a BD-LIVE compatible disc.

NOTE for SD memory card

- Insert or remove a SD memory card while the power is in standby. If you insert a SD memory card while the power is ON, the SD memory card may not be read.
- Use an SD memory card with a capacity of 1 GB or greater. Also, the SD memory card must be formatted on this unit (page 46).
- Remove the write protection of a SD memory card.

Playing BD-Video Compatible with Bonus View

With a disc that is compatible with bonus view (picture-in-picture), besides the main video (primary video) stored on the disc, you can play back the video director's commentary and simultaneously ongoing sub-story, as well as sub-video such as alternative camera angle (secondary video).

- The playback method, etc., is determined by the disc, and varies depending on the disc.
- For details on the functions and how to operate them, see the individual disc's on-screen displays and explanations.
- Some Blu-ray Discs use SD memory cards as the recording memory for Bonus View playback. You should install an SD memory card before using these discs.

Press **MODE** and Δ / ∇ to select the secondary video you want to play back.

Off \rightarrow 1/X \rightarrow 2/X \rightarrow X/X

Off	Does not display secondary video.
1/X	* Displays the first secondary video.
2/X	* Displays the second secondary video.
X/X	* Displays the X th secondary video.

* "X" is the number of Secondary Videos recorded and differs depending on the disc.

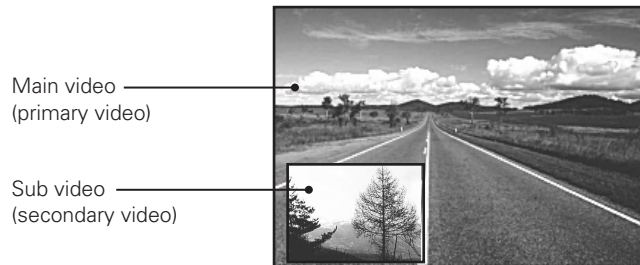
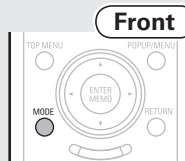

[Example] Bonus view

Playing CD



1 Prepare for playback.
Turn on the subwoofer power.

2 Press ON to turn on power to the unit.

3 Insert a disc.
• Press \blacktriangle on the main unit to open/close the disc tray.

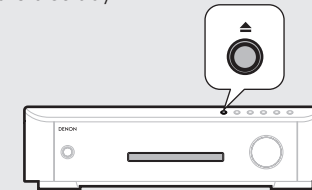

- When the disc tray opens, the input source automatically switches to "BD/SD" and the unit enters "Disc Mode".
- If a disc is already inserted in the disc tray, switch to "Disc Mode" by selecting **BD/SD**.

4 Press \blacktriangleright .
Playback starts.

- Adjusting the Master Volume** (page 28)
Press **VOL \blacktriangle / \blacktriangledown** .
- Stop Playback** (page 28)
Press **■**.
- Pause Playback** (page 28)
Press **II**.
- Fast Forward/Fast Reverse Playback** (page 29)
During playback, press **⏩/⏪**.
- Skipping to the Track** (page 29)
During playback, press **⏮/⏭** or **Δ / ∇** .
- Random Playback** (page 29)
During stop, press **RANDOM**.
- Repeat Playback** (page 29)
Press **REPEAT**.

The icons show the category of content applicable to each operation.



Video



Audio



Photo

For details of the media corresponding to each icon, see "Playable Media" (page 19).

Getting Started
Simple Version
Connections
Playback (Basic)
Settings
Playback (Advanced)
Multi-zone
GUI
Remote Control
Part Names
Other Information
Troubleshooting
Spec.
Index



Playing an iPod®

There are two methods for iPod playback.

- ① **Use the DENON Control dock for iPod to play back.**
You can play back both video and audio.
- ② **Connect the iPod directly to the USB port to play back.**
You can play back audio only.

① Use the DENON Control Dock for iPod to Play Back



DENON Control dock for iPod usable on this unit
 • ASD-11R/ASD-3N/ASD-3W/ASD-51N/ASD-51W

Listening to Music on an iPod®

1 Prepare for playback.

Connect the DENON control dock for iPod to this unit (☞ page 14 "Connecting a Control Dock for iPod").

2 Press AUX to select "DOCK".

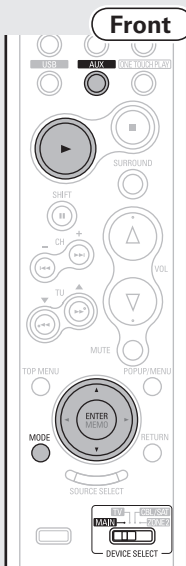
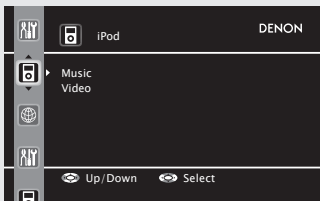

- When communication between this unit and the iPod is completed, the following connection screen is displayed on the iPod.

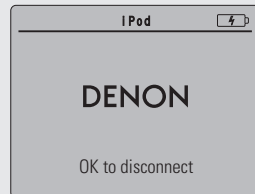

- If the connections screen is not displayed, the iPod may not be properly connected. Reconnect it.

3 Press MODE to select the display mode.

- There are two modes for display the contents recorded on the iPod.

Browse mode Display iPod information on the TV screen.

- * With the display of this unit, only English letters and numbers can be displayed. Any characters that cannot be displayed are replaced with "*".

Remote mode Display iPod information on the iPod screen.

- * "Remote Dock" is displayed on the display of this unit.

	Display mode	Browse mode	Remote mode
Playable files	Music file	✓	✓
	Photo file		✓ *
	Video file	✓	✓ *
Active buttons	Remote control unit (This unit)	✓	✓
	iPod®		✓

- * Video may not be output, depending on the combination of ASD-11R/3N/3W/51N/51W DENON control dock for iPod and iPod.

4 Use Δ∇ to select the item, then press ENTER to select the file to be played.

5 Press ▶.

Playback starts.

- ☐ **Adjusting the Master Volume** (☞ page 28)
Press **VOL ▲▼**.

- ☐ **Stop Playback** (☞ page 28)
Press **■**.

- ☐ **Pause Playback** (☞ page 28)
Press **⏸** or **ENTER**.

- ☐ **Fast Forward/Fast Reverse Playback** (☞ page 29)
During playback, press **⏩⏪**.

- ☐ **Skipping to the Track** (☞ page 29)
During playback, press **⏮⏭** or **Δ∇**.

- ☐ **Repeat Playback** (☞ page 29)
Press **REPEAT**.

- ☐ **Shuffling Playback** (☞ page 24)

- ☐ **Switching the Display Page** (☞ page 24)
Press **SEARCH**, then press **◀** (previous page) or **▶** (next page). (only ASD-11R)
Press **⏮** (previous page) or **⏭** (next page). (ASD-3N / 3W / 51N / 51W)



- To play back compressed audio with extended bass or treble reproduction, we recommend playback in RESTORER mode (☞ page 26). The default setting is "Mode 3".
- In Browse mode, press **DISPLAY** during playback to check the title name, artist name, and album name.

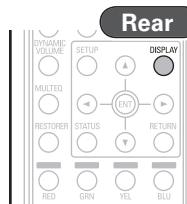

NOTE

- Press **OFF** and set this unit's power to the standby mode before disconnecting the iPod. Also switch the input source to one to which the menu "AUX1" is not assigned before disconnecting the iPod.
- Depending on the type of iPod and the software version, some functions may not operate.
- Note that DENON will accept no responsibility whatsoever for any problems arising with the data on an iPod when using this unit in conjunction with the iPod.

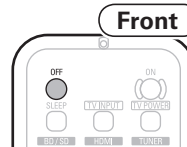

Video



Audio



Photo

Viewing Videos on an iPod® in the Browse Mode

When an iPod equipped with a video function is connected to a DENON ASD-11R control dock for iPod, image files can be played in the browse mode.

- 1 Use Δ / ∇ to select “Videos”, then press **ENTER**.
- 2 Use Δ / ∇ to select the search item or folder, then press **ENTER**.
- 3 Use Δ / ∇ to select the video file, then press **ENTER**. Playback starts.

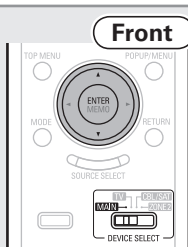

Viewing Photos and Videos on an iPod® in the Remote Mode

This unit can play back on a TV screen photos and data stored on an iPod equipped with a slide show or video function.

- 1 Press **MODE** to set the Remote mode. “Remote Dock” is displayed on the display of this unit.
- 2 Watching the iPod’s screen, use Δ / ∇ to select “Photos” or “Videos”.
 - Depending on the iPod used, you may need to operate the iPod unit directly.
- 3 Press **ENTER** until the image you want to view is displayed.

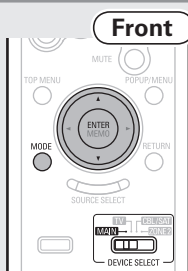

“TV Out” at the iPod’s “Slide show Settings” or “Video Settings” must be set to “On” in order to display the iPod’s photo data or videos on the monitor. For details, see the iPod’s operating instructions.

NOTE

Video may not be output, depending on the combination of ASD-11R / 3N / 3W / 51N / 51W DENON control dock for iPod and iPod.

2 Connect the iPod Directly to the USB Port to Play Back



You can use the USB cable provided with the iPod® to connect the iPod with the unit’s USB port and enjoy music stored on the iPod.

- This unit supports audio playback from the iPod (fifth generation or later), iPod nano, iPod classic, and iPod touch (it is not compatible with iPod shuffle).

- 1 Connect the iPod to the USB port (☞ page 14 “Connecting an iPod or USB Memory Device to the USB Port”).

Playback starts automatically.

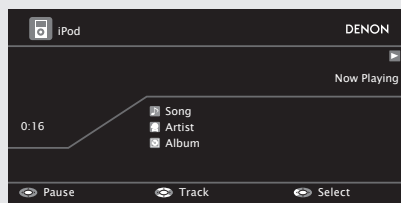

- If the screens above are not displayed, the iPod may not be properly connected. Try connecting again.

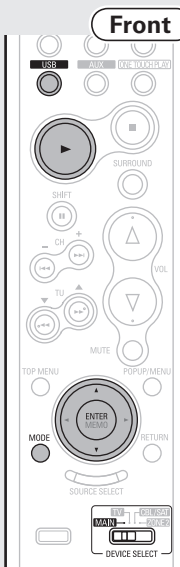

2 Press MODE to select the display mode.

- There are two modes for display the contents recorded on the iPod.

Browse mode Display iPod information on the TV screen.

- * With the display of this unit, only English letters and numbers and certain symbols can be displayed. Any characters that cannot be displayed are replaced with “*”.

Remote mode Display iPod information on the iPod screen.

- * “Remote iPod” is displayed on the display of this unit.
- The Remote mode is not supported on fifth generation iPods or iPod nanos.

Display mode		Browse mode	Remote mode
Playable files	Music file	✓	✓
	Video file		✓ *
Active buttons	Remote control unit (This unit)	✓	✓
	iPod®		✓

* Only the sound is played.

- 3 Use Δ / ∇ to select the item, then press **ENTER** to select the file to be played.
- 4 Press **▶**. Playback starts.

- Adjusting the Master Volume** (☞ page 28)
Press **VOL ▲▼**.
- Stop Playback** (☞ page 28)
Press **■**.
- Pause Playback** (☞ page 28)
Press **||** or **ENTER**.
- Fast Forward/Fast Reverse Playback** (☞ page 29)
During playback, press **◀◀▶▶**.
- Skipping to the Track** (☞ page 29)
During playback, press **◀◀▶▶** or Δ / ∇ .
- Repeat Playback** (☞ page 29)
Press **REPEAT**.
- Shuffling Playback** (☞ page 24)
Press **RANDOM**.

The icons show the category of content applicable to each operation.



Video



Audio



Photo

For details of the media corresponding to each icon, see “Playable Media” (☞ page 19).

Getting Started

Simple Version

Connections

Playback (Basic)

Settings

Playback (Advanced)

Multi-zone

GUI

Remote Control

Part Names

Other Information

Troubleshooting

Spec.

Index



Playing an iPod®



- To play back compressed audio with extended bass or treble reproduction, we recommend playback in RESTORER mode (page 26). The default setting is “Mode 3”.
- In Browse mode, press **DISPLAY** during playback to check the title name, artist name, and album name.

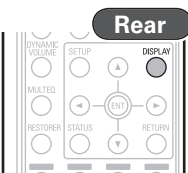

NOTE

- Depending on the type of iPod and the software version, some functions may not operate.
- Note that DENON will accept no responsibility whatsoever for any problems arising with the data on an iPod when using this unit in conjunction with the iPod.
- It is not possible to playback LPCM files recorded on an iPod.



“Made for iPod” means that an electronic accessory has been designed to connect specifically to iPod and has been certified by the developer to meet Apple performance standards. Apple is not responsible for the operation of this device or its compliance with safety and regulatory standards.

iPod is a trademark of Apple Inc., registered in the U.S. and other countries.

- The iPod may only be used to copy or play content that are not copyrighted or content for which copying or playback is legally permitted for your private use as an individual. Be sure to comply with applicable copyright legislation.

Shuffling Playback



1 During playback, press **RANDOM**.
 is displayed on the screen.

- The mode is switched each time the button is pressed.

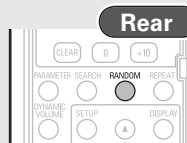

Display	Setting contents
Songs	Shuffle songs.
Albums	Shuffle albums.
OFF	Cancel shuffle mode.

2 Press **▶**.
 Playback starts.

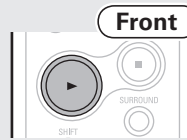

Switching the Display Page



Press **SEARCH**, then press **◀** (previous page) or **▶** (next page).

- To cancel, press **SEARCH**.

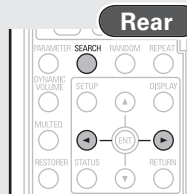

Playing a USB Memory Device



Playing back music files recorded on a USB memory device.

1 Connect the USB memory device to the USB port (page 14 “Connecting an iPod or USB Memory Device to the USB Port”). Playback starts automatically.

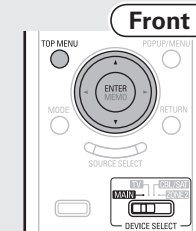
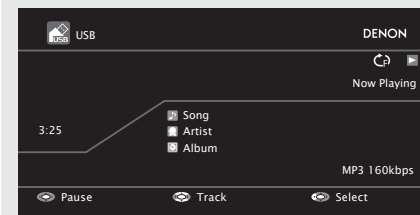

2 Press **TOP MENU**, select the folder or file you want to play back using **Δ**/**∇** and press **ENTER**.

- Adjusting the Master Volume** (page 28)
 Press **VOL ▲/▼**.
- Stop Playback** (page 28)
 Press **■**.
- Pause Playback** (page 28)
 Press **⏸** or **ENTER**.
- Fast Forward / Fast Reverse Playback** (page 29)
 During playback, press **⏩/⏪**.
- Skipping to the File** (page 29)
 During playback, press **⏮/⏭** or **Δ/∇**.
- Repeat Playback** (page 29)
 Press **REPEAT**.
- Random Playback** (page 29)
 Press **RANDOM**.
- Switching the Display Page** (page 24)



To play back compressed audio with extended bass or treble reproduction, we recommend playback in RESTORER mode (page 26). The default setting is “Mode 3”.

NOTE

- Note that DENON will accept no responsibility whatsoever for any problems arising with the data on a USB memory device when using this unit in conjunction with the USB memory device.
- It is not possible to play back LPCM or JPEG files recorded on a USB memory device.



Video



Audio



Photo

Playing Files

The limits on the number of folders and files that can be displayed by this unit are as follows.

Maximum Number of Playable Files and Folder

Item	Media	Disc or SD memory card	USB memory device
Number of folder directory levels		8 levels	8 levels
Number of folders		999	2000
Number of files		9999	6000

- The limited number includes the root folder.

Maximum Number of Text Display Characters

Item	Media	Disc or SD memory card	USB memory device
File name, Folder name		32	64
Artist name, title, etc.		60	64

- Text more than one line is scroll displayed.
- If characters not supported on the menu screen are included in a file name, title, artist name or album title, those are not displayed correctly.

Playing File

1 Press BD/SD to select "Disc Mode" or "SD Mode".

Disc Mode When playing back files stored on a DVD or CD.

SD Mode When playing back files stored on an SD memory card.

2 Load media.

The file browser screen will appear.

- See "Inserting a Disc" (page 65) and "SD CARD slot" (page 62) for how to load media.
- When file browser screen does not appear, press **POPUP/MENU**.



3 Press MODE to select a playback mode.

Disc Plays back all files in the media.

Folder Plays back files in the selected folder. is displayed in the playback mode indicator.

4 Select a folder of the data to be played back and press ENTER.

- $\Delta \nabla \leftarrow \rightarrow$ Display screen selection
- RETURN** To next level up
- ENTER** To next level down
- TOP MENU** To the top level

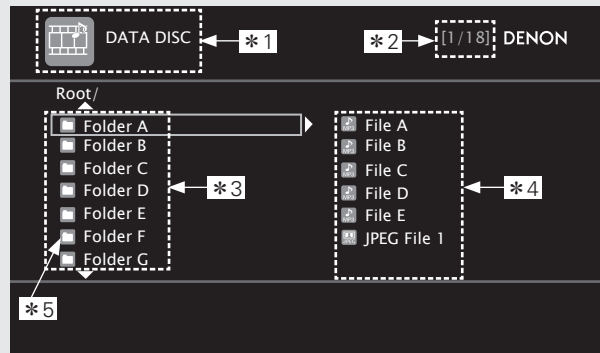

- *1 Media currently playing back
- *2 Selected folder number/Total number of folders
- *3 Current level folder or file list
- *4 Files inside selected folder
- *5 Folder icon

5 Use $\Delta \nabla$ to select a file, and press ENTER to play back.

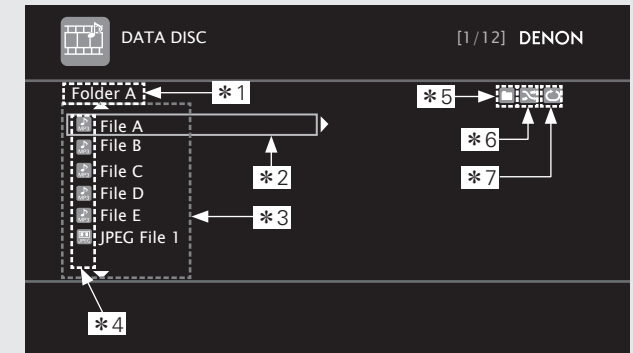

- *1 Current level folder name
- *2 Selected file
- *3 File for playback
- *4 File types
- *5 Folder mode
- *6 Random playback mode
- *7 Repeat playback mode

Switching the Display Page

Press \rightarrow to display the next page.
Press \leftarrow to display the previous page.

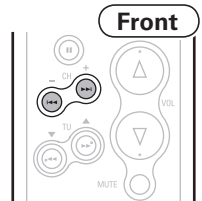

- For playable media and files, see "Playable Media" (page 19).
- To play back compressed audio with extended bass or treble reproduction, we recommend playback in RESTORER mode (page 26). The default setting is "Mode 3".

NOTE

This unit cannot play back an SD memory card containing video recorded with a digital camcorder.

The icons show the category of content applicable to each operation.



Video



Audio



Photo

For details of the media corresponding to each icon, see "Playable Media" (page 19).

Tuning in Radio Stations

Listening to FM/AM Broadcasts

1 Press **TUNER** to select “FM” or “AM”.

FM When listening to an FM broadcast.

AM When listening to an AM broadcast.

2 Tune in the desired broadcast station.

① To tune in automatically (Auto Tuning)

Press **MODE** to light the “AUTO” indicator on the display, then use **TU ▲** or **TU ▼** to select the station you want to hear.

• To cancel Auto tuning, press **TU ▲** or **TU ▼**.

② To tune in manually (Manual Tuning)

Press **MODE** to turn off the display’s “AUTO” indicator, then use **TU ▲** or **TU ▼** to select the station you want to hear.



❑ **Adjusting the Master Volume** (page 28)

Press **VOL ▲▼**.



- If the desired station cannot be tuned in with auto tuning, tune it in manually.
- When tuning in stations manually, press and hold **TU ▲** or **TU ▼** to change frequencies continuously.

Presetting Radio Stations (Manual Preset)

Your favorite broadcast stations can be preset so that you can tune them in easily. Up to 56 stations can be preset. Multicasts can also be preset.

• Stations can be preset automatically at “Auto Preset” (page 48). If “Auto Preset” is performed after performing “Manual Preset”, the “Manual Preset” settings will be overwritten.

1 Tune in the broadcast station you want to preset.

2 Press **MEMO**.

3 Press **SHIFT** to select the block (A to G) in which the channel (1 to 8 per a block) is to be preset, then press **CHANNEL +, –** or **1 – 8** to select the preset number.

4 Press **MEMO** again to complete the setting.
To preset other stations, repeat steps 1 to 4.

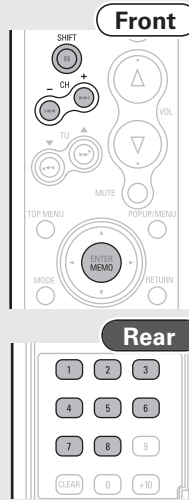

❑ **Default Settings**

Block (A – G) and Channel (1 – 8)	Default Settings
A1 – A8	87.5 / 89.1 / 98.1 / 107.9 / 90.1 / 90.1 / 90.1 / 90.1 MHz
B1 – B8	520 / 600 / 1000 / 1400 / 1500 / 1710 kHz, 90.1 / 90.1 MHz
C1 – C8	90.1 MHz
D1 – D8	90.1 MHz
E1 – E8	90.1 MHz
F1 – F8	90.1 MHz
G1 – G8	90.1 MHz

❑ **Specify a Name for the Preset Broadcast Station (Preset Name)** (page 48)

Listening to Preset Stations

1 Press **SHIFT** to select the memory block.

2 Press **CHANNEL +, –** or **1 – 8** to select the desired preset channel.

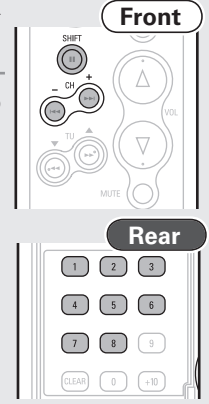

You can also operate via the main unit. In this case, perform the following operations. Press **PRESET +** or **PRESET –** to select the preset radio station.

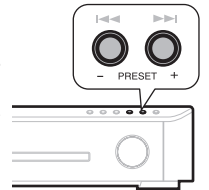

Direct Frequency Tuning

You can enter the receiving frequency directly to tune in.

1 Press **SEARCH**.

2 Input frequencies using **0 – 9**.

• If **◀** is pressed, the immediately preceding input is cancelled.

3 When setting is completed, press **ENTER**.
The preset frequency is tuned in.

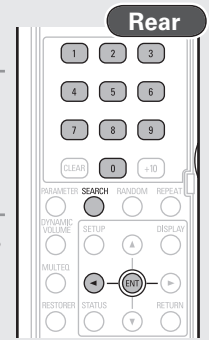

- Getting Started
- Simple Version
- Connections
- Playback (Basic)
- Settings
- Playback (Advanced)
- Multi-zone
- GUI
- Remote Control
- Part Names
- Other Information
- Troubleshooting
- Spec.
- Index



Basic Operation

Playback (Basic) (👉 page 18)

- Adjusting the Master Volume** (👉 page 28)
- Stop Playback** (👉 page 28)
- Pause Playback** (👉 page 28)
- Step-by-Step Playback** (👉 page 28)
- Fast Forward/Fast Reverse Playback** (👉 page 29)
- Slow Forward/Slow Reverse Playback** (👉 page 29)
- Skipping to the Chapter/Track/File** (👉 page 29)
- Random Playback** (👉 page 29)
- Repeat Playback** (👉 page 29)
- Switching Audio** (👉 page 30)
- Switching the Angle** (👉 page 30)
- Changing the Subtitles and Subtitle Style** (👉 page 31)

Surround Mode (👉 page 31)

Playback (Advanced) (👉 page 37)



Performance of the following operations can sometimes result in video discontinuities.

- Pause Playback
- Step-by-Step Playback
- Slow Forward/Slow Reverse Playback

If this happens, stop playback, then press **SETUP** and on the GUI menu switch "Display Setup" – "Still Mode" to "Field" (👉 page 46).

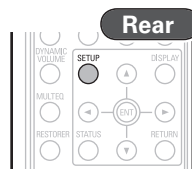

Adjusting the Master Volume



Press **VOL ▲▼** to adjust the volume.

[Variable range] 0 – 99

- The variable range differs according to the input signal and channel level setting.

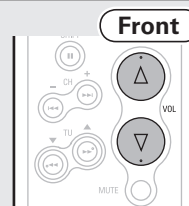

You can also operate via the main unit. In this case, perform the following operations. Use **VOLUME** to adjust the volume.

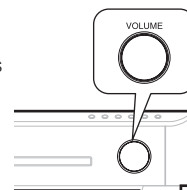

Stop Playback



During playback, press **■**.

Playback stops.

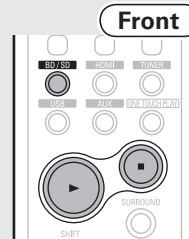

About Resume Function



When playback is stopped, the stop position is memorized.

- The ► indicator flashes on the display. When playing back data from the stop position, press ► while stop by the resume function.

To Cancel the Resume Function

Perform one of the following operations.

- During stop, press **■**.
- Change the playback media mode with **BD/SD**.
- Open the disc tray.
- Remove the SD memory card.



- The resume function remains valid even when the standby mode is set.
- The resume function is cancelled when the power is turned off by unplugging the power cord.

NOTE

- The resume function does not work with menu playback or BD-J (Blu-ray Disc Java) compatible disc.

Pause Playback



During playback, press **⏸**.

The **⏸** indicator will light on the display.

- Resume normal playback by pressing ►.

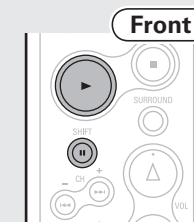

Step-by-Step Playback



During pause, press **⏸**.

The disc advances frame by frame each time the button is pressed.

- Resume normal playback by pressing ►.

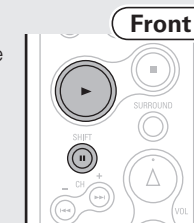

NOTE

Step-by-step reverse playback is not available with this unit.



Fast Forward/Fast Reverse Playback



During playback, press ◀◀ or ▶▶.

- The fast forward/fast reverse speed changes each time the button is pressed.
- Speed varies with the disc and file.

- Resume normal playback by pressing ▶.

Front

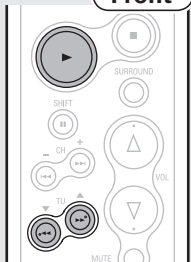

NOTE

- You cannot fast forward/fast reverse across files or tracks during program or random playback.
- Audio is not output during fast forward/fast reverse of a Blu-ray Disc or DVD.

Slow Forward/Slow Reverse Playback



During pause, press ◀◀ or ▶▶.

The speed changes each time the button is pressed.

- The speed of the slow reverse playback is not switched.
- Resume normal playback by pressing ▶.

Front



Audio is not output during slow forward/slow reverse playback.

Skipping to the Chapter/Track/File



During playback, press |◀◀ or ▶▶|.

◀◀ Playback begins from the start of the chapter/track/file being played.

▶▶ Playback begins from the start of the next chapter/track/file.

- Continue pressing and skip to the chapter/track/file with just the number of times pressed.

Front

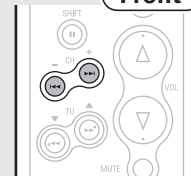

NOTE

Skipping to the start of a title may be prohibited depending on the disc.

Random Playback



1 During stop, press **RANDOM**.
The "RAND" lights on the display and is displayed on the screen.

2 Press ▶.
Playback starts.

Rear



Front



Resuming Normal Playback

During stop, press **RANDOM**.

NOTE

Random playback may not be enabled depending on the disc.

Repeat Playback



1 Press **REPEAT**.

The repeat mode icon is displayed at the top of the screen.

- The repeat mode changes each time the button is pressed.

Rear

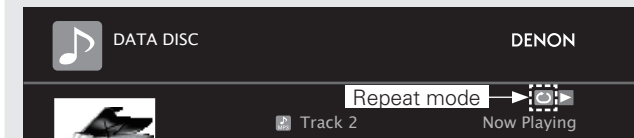

[About Repeat Mode]

Settable repeat modes vary depending on the disc or file you are playing back.

Contents	Repeat mode display		
Mode			
Chapter repeat	✓		
Track repeat		✓	✓
Title repeat	✓		
All repeat		✓	✓
Folder repeat		✓*	

* Only when playing back files in a USB memory device

Resuming Normal Playback

Press **REPEAT**.

NOTE

- Some repeat modes may not be accessible depending on the disc.
- Depending on the disc, even when set to repeat playback, the disc may not return to the start of title or chapter, and may advance to the next scene.
- There is no "Off" setting in the USB memory device repeat mode.



Video



Audio



Photo



Basic Operation

Switching Audio



With discs and files that have multiple audio track recording, you can change the audio during playback.

With Blu-ray Disc, you can set sub-track audio such as interactive audio and audio commentary, etc., with "Secondary".

Switching a Blu-ray Disc's Primary Audio/Secondary Audio

1 During playback of a Primary Audio/Secondary Audio title, press AUDIO/RDS.

The audio number currently being played is displayed.

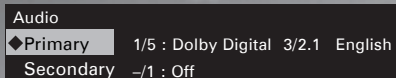

Rear



2 Press Δ / ∇ , select "Primary" or "Secondary", and then press ENTER.

- If multiple audio items are recorded, "the current audio number/number of recorded audio items" is displayed.
- When "BD Audio Mode" is set to "HD Audio Output" (page 58), "Secondary" audio is not output.

3 Select your desired audio language with Δ / ∇ .

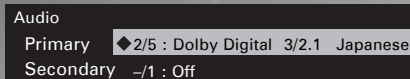

4 Press AUDIO/RDS.

The setup screen disappears.



- Depending on the disc, audio switching may be restricted to operation of the disc menu. In this case, switch the audio on the disc menu.
- Be sure to set "BD Audio Mode" to "Mix Audio Output" (page 58) for playing back secondary audio.
- Depending on the Blu-ray Disc, even if picture-in-picture playback is set to "Off", Secondary Audio only may be output.

Audio Switching (Media Other than Blu-ray Disc)

1 During playback, press AUDIO/RDS.

The audio number currently being played is displayed.

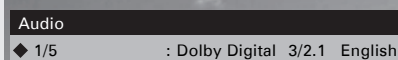

Rear



2 Use Δ / ∇ to select audio.

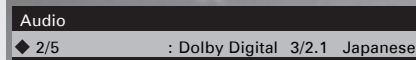

3 Press AUDIO/RDS.

The setup screen disappears.

NOTE

- Audio switching may vary depending on the playback media used.
- With DTS-CD (5.1 music disc), you cannot switch audio modes.

Switching the Angle



During playback of a Blu-ray Disc or DVD-Video recorded with several camera angles, you can change the angle.

1 During playback, press ANGLE/RT.

The angle number currently being played is displayed.



2 Use Δ / ∇ to select angle.



3 Press ANGLE/RT.

The setup screen disappears.



NOTE

Angle changing may be restricted, depending on the disc.



Video



Audio



Photo

Changing the Subtitles and Subtitle Style



During playback of a disc or file with recorded subtitles, you can switch subtitle on/off as well as subtitle language. With Blu-ray Disc, you can change the style of displayed subtitles.

Switching a Blu-ray Disc's Primary Subtitle/ Secondary Subtitle and Subtitle Style

- 1 During playback, press **SUBTITLE/PTY.**
The subtitle number currently being played is displayed.

Subtitle
 ◆ Primary 1/5 : English
 Secondary -/1 : Off
 Style 1 :

- 2 With Δ / ∇ , select “Primary”, “Secondary” and “Style”, and then press **ENTER**.

- 3 Use Δ / ∇ to select your desired subtitle language and subtitle style.

Subtitle
 Primary ◆ 1/5 : English
 Secondary -/1 : Off
 Style 1 :

- 4 Press **SUBTITLE/PTY.**
The setup screen disappears.



- If a disc does not include subtitles and subtitle style, “Not Available” is displayed.
- Depending on the disc, subtitle switching may be restricted to operation of the disc menu. In this case, switch the subtitles on the disc menu.

Selecting DVD-Video Subtitle

- 1 During playback, press **SUBTITLE/PTY.**

The subtitle number currently being played is displayed.

Subtitle
 ◆ 1/5 : Off

- 2 Use Δ / ∇ to select subtitle.

Subtitle
 ◆ 1/5 : English

Surround Mode

You can select surround mode to enjoy surround playback with your favorite acoustic field effects.



Surround mode setting items will vary depending on the combination of speakers connected and input signals.

Playing Back Surround Sound Using 2.0-channel or 2.1-channel Speakers

When your speaker system is 2.0-channel or 2.1-channel, you can select one of the following modes.

- 1 Playing the source (👉 page 20).

- 2 Press **SURROUND** to select the surround mode.



STEREO This is the mode for playing stereo. If the input signal is multi-channel, down-mix to 2.1-channel or 2-channel.

DOLBY VS REFERENCE This is the standard mode for Dolby Virtual Speaker.

DOLBY VS WIDE This mode emphasizes a wide feel.

- 3 Press **PARAMETER** to select a mode aligned with the source.

Cinema This mode is suited for movie sources.

Music This mode is suited for music sources.

- You cannot perform this operation if the input signal is multi-channel, or if the surround mode is “STEREO”.



Surround Playback Using more than 2.1-channel Speakers

The selectable surround modes depend on the following:

- Format of the audio signals being input
- Number of channels of the audio signals being input
- The set speaker assignment (👉 page 53)

1 Playing the source (👉 page 20).

2 Press SURROUND to select the surround mode.

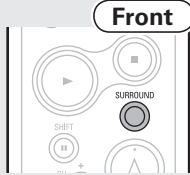

- STEREO** This is the mode for playing stereo. Sound is output from the front left and right speakers and subwoofer.
- *** This mode is for surround playback aligned with the source.
- MULTI CH STEREO** This is an original DENON surround mode. This mode is for enjoying stereo sound from all speakers.
- ROCK ARENA** This is an original DENON surround mode. This mode is for enjoying the atmosphere of a live concert in an arena.
- JAZZ CLUB** This is an original DENON surround mode. This mode is for enjoying the atmosphere of a live concert in a jazz club.

* The displayed surround mode changes depending on factors such as the input signal and speaker settings (👉 page 69).

3 [When “*” was selected in Step 2] Press PARAMETER to select a mode aligned with the source.

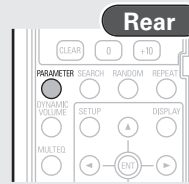

- The modes that can be selected depend on the input source being played.

When Performing Surround Playback for a 2-channel Source

- DOLBY PLII Cinema** *1 The signals are decoded in DOLBY PLII for surround playback. This mode is suited for movie sources.
- DOLBY PLII Music** *1 The signals are decoded in DOLBY PLII for surround playback. This mode is suited for music sources.
- DOLBY PLII Game** *1 The signals are decoded in DOLBY PLII for surround playback. This mode is suited for games.
- DTS NEO:6 Cinema** The signals are decoded in DTS NEO:6 for surround playback. This mode is suited for movie sources.
- DTS NEO:6 Music** The signals are decoded in DTS NEO:6 for surround playback. This mode is suited for music sources.
- DOLBY PLIIz Height** *2 The signals are decoded in DOLBY PLIIz for surround playback. This is the Front Height playback mode. You can select this when the “Front Height” setting is “ON” (👉 page 49).

- *1 When the two conditions below are satisfied, signals are decoded in DOLBY PLIIx for surround playback. In this case, the display shows “DOLBY PLIIx”.
 - Set “Speaker Assign” to “5.1CH + Surround Back” (👉 page 53).
 - Set “Speaker Configuration” – “Surround Back” to something other than “None” (👉 page 54).
- *2 You can select this when the following 3 conditions are satisfied.
 - Set “Speaker Assign” to “5.1CH + Front Height” (👉 page 53).
 - Set “Speaker Configuration” – “Front Height” to something other than “None” (👉 page 54).
 - Set “Front Height” to “ON” (👉 page 49).

When the Multi-channel Source is Surround Playback

When the “Speaker Assign” setting on the GUI menu is “5.1CH + Surround Back”, you can select the parameters.

- Depending on the input signal, there may be signals that you cannot select.

[Displaying the Currently Playing Surround Mode]

Input signal	Display
DOLBY DIGITAL (other than 2ch)/ DOLBY DIGITAL EX	DOLBY DIGITAL
	DOLBY DIGITAL EX
DOLBY DIGITAL Plus	DOLBY DIGITAL+ PLIIx CINEMA
	DOLBY DIGITAL+ PLIIx MUSIC
	DOLBY DIGITAL+ PLIIz HEIGHT * 1
	DOLBY DIGITAL+ + EX
DOLBY TrueHD	DOLBY DIGITAL+ + PLIIx CINEMA
	DOLBY DIGITAL+ + PLIIx MUSIC
	DOLBY DIGITAL+ + PLIIz HEIGHT * 1
	DOLBY TrueHD
DTS (5.1ch)/ DTS-ES Discrete 6.1/ DTS-ES Matrix 6.1/ DTS 96/24	DOLBY TrueHD+ EX
	DOLBY TrueHD+ PLIIx CINEMA
	DOLBY TrueHD+ PLIIx MUSIC
	DOLBY TrueHD+ PLIIz HEIGHT * 1
DTS-HD	DTS SURROUND
	DTS+ PLIIx CINEMA
	DTS+ PLIIx MUSIC
	DTS+ PLIIz HEIGHT * 1
	DTS+ NEO:6
PCM (multi ch)	DTS ES MTRX6.1 * 2
	DTS ES DSCRT6.1 * 3
	DTS 96/24 * 4
	DTS-HD HI RES
DTS-HD	DTS-HD MSTR
	DTS-HD+ NEO:6
	DTS-HD+ PLIIx CINEMA
	DTS-HD+ PLIIx MUSIC
	DTS-HD+ PLIIz HEIGHT * 1
DTS EXPRESS	DTS EXPRESS
	MULTI CH IN
	MULTI IN+ PLIIz HEIGHT * 1
MULTI CH IN 7.1	MULTI CH IN 7.1

- * 1 You can select this when the “Speaker Assign” setting on the GUI menu is “5.1CH + Front Height” (👉 page 53).
- * 2 This is displayed when the input signal is “DTS-ES Matrix 6.1” and this unit’s “AFDM” setting is set to “ON” (👉 page 49).
- * 3 This is displayed when the input signal is “DTS-ES Discrete 6.1”.
- * 4 This is displayed when the input signal is “DTS 96/24”.



For details, see page 68.

Advanced Version



Here, we explain functions and operations that let you make better use of this unit.

- **Settings for Speakers Other Than 5.1-channel**
- **Playback (Advanced)**
- **Playback (Multi-zone Function) in ZONE2 (Separate Room)**
- **How to Make Detailed Settings**
- **Operating the Connected Devices by Remote Control Unit**

Settings for Speakers Other Than 5.1-channel

Here we describe the installation, connection and setup methods for speakers other than 5.1-channel speakers. For the installation, connection and setup methods for 5.1-channel speakers, see "Simple Version" (👉 page 3).

□ Procedure for speaker settings

Install

Connect (👉 page 35)

Set Up Speakers (👉 page 36)

Install

This unit is compatible with Dolby Pro Logic IIz (👉 page 73), which offers an even wider and deeper surround sensation. When using Dolby Pro Logic IIz, install front height speakers.



Install the surround back speakers in a position 2 to 3 feet/60 to 90cm higher than ear level.

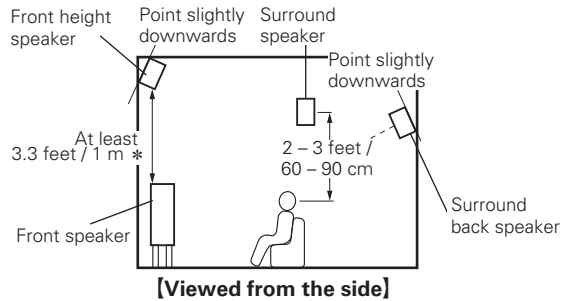

* Recommended for Dolby Pro Logic IIz

NOTE

It is not possible to use the surround back speakers and front height speakers simultaneously.

□ When 7.1ch (Front Height Speaker) Installed

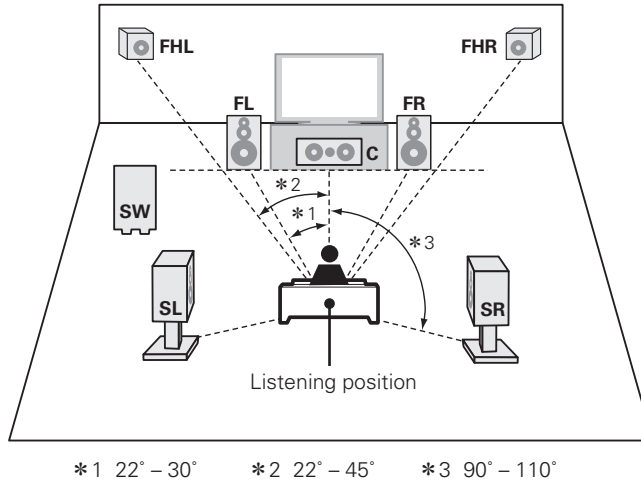

*1 22° - 30° *2 22° - 45° *3 90° - 110°

□ When 6.1ch (Surround Back Speaker) Installed

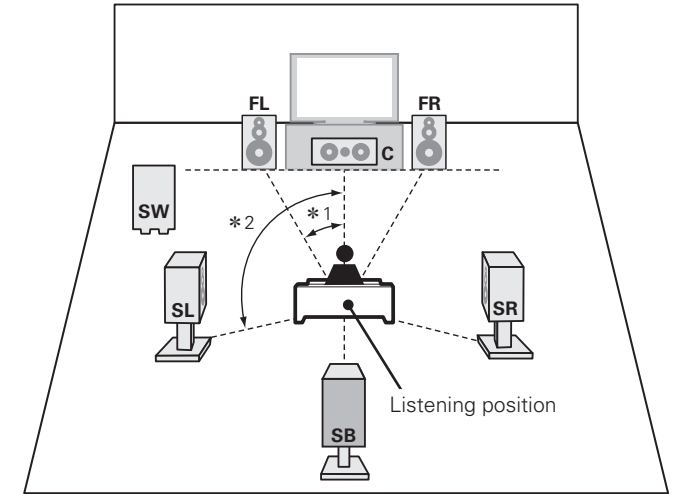

*1 22° - 30° *2 90° - 110°

□ When 7.1ch (Surround Back Speaker) Installed

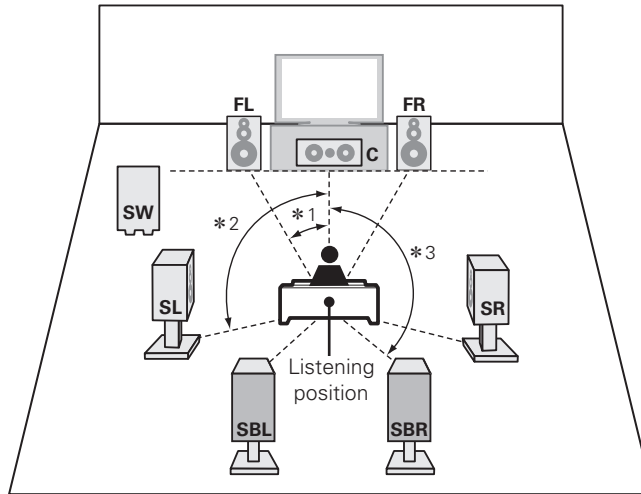

*1 22° - 30° *2 90° - 110° *3 135° - 150°

□ When 2.1ch Installed

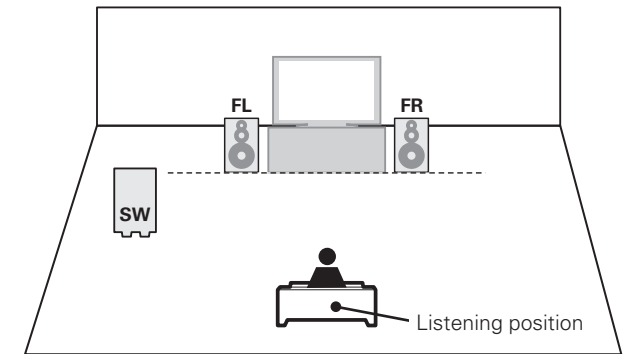

- FL Front speaker (L)
- FR Front speaker (R)
- C Center speaker
- SW Subwoofer
- SL Surround speaker (L)
- SR Surround speaker (R)
- SBL Surround back speaker (L)
- SBR Surround back speaker (R)
- FHL Front height speaker (L)
- FHR Front height speaker (R)

Connect

- For the method of connecting 5.1-channel speakers, see page 4.
- For the method of connecting the TV, see page 5.

7.1-channel (Front Height Speaker) Connection

- A power amplifier (sold separately) is required for this connection.
- For 7.1-channel (Front height speaker) playback, set "Speaker Assign" in "Set Up Speakers" (page 36) to "5.1CH + Front Height".

7.1-channel/6.1-channel (Surround Back Speaker) Connection

- A power amplifier (sold separately) is required for this connection.
- For 7.1-channel (Surround back speaker) playback, set "Speaker Assign" in "Set Up Speakers" (page 36) to "5.1CH + Surround Back".

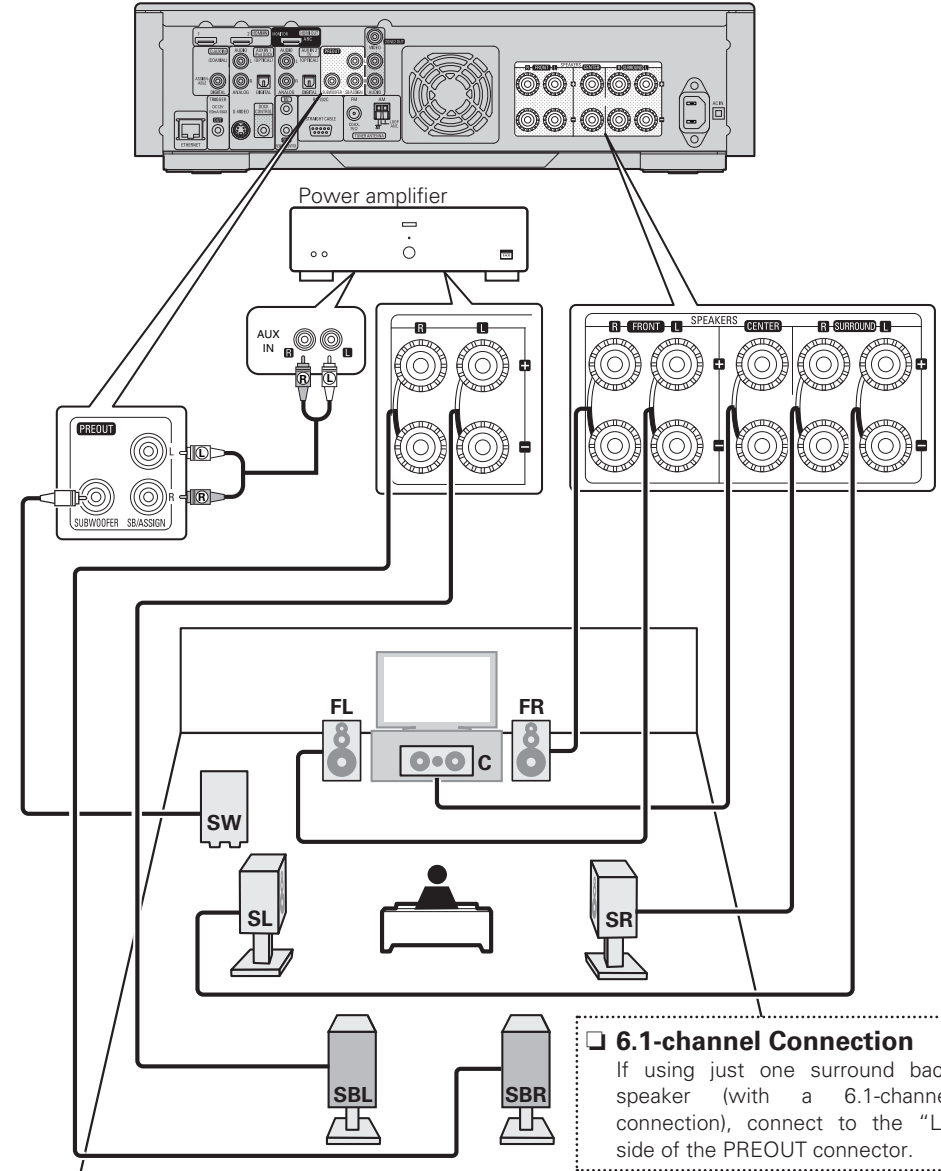
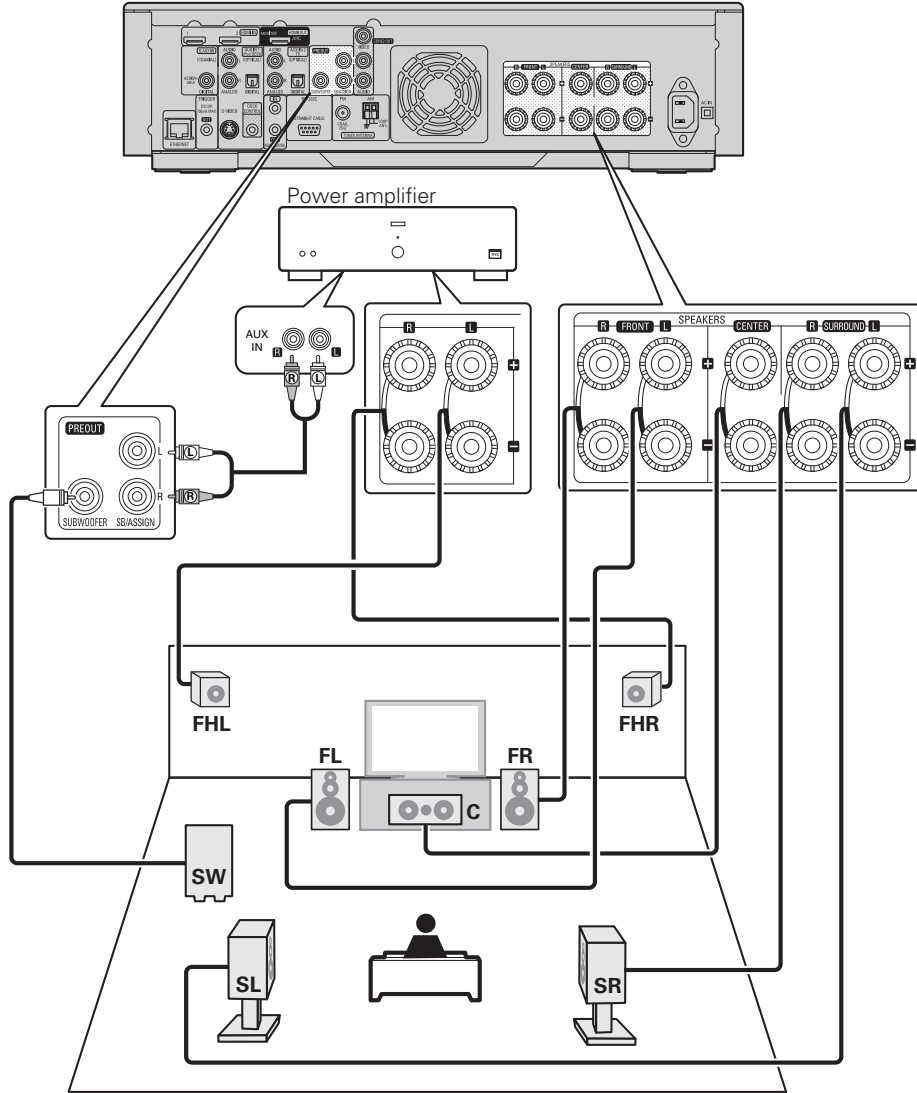

6.1-channel Connection
 If using just one surround back speaker (with a 6.1-channel connection), connect to the "L" side of the PREOUT connector.

- Getting Started
- Simple Version
- Connections
- Playback (Basic)
- Settings (Advanced)
- Playback (Advanced)
- Multi-zone
- GUI
- Remote Control
- Part Names
- Other Information
- Troubleshooting
- Spec.
- Index



Connect

2.1-channel Connection

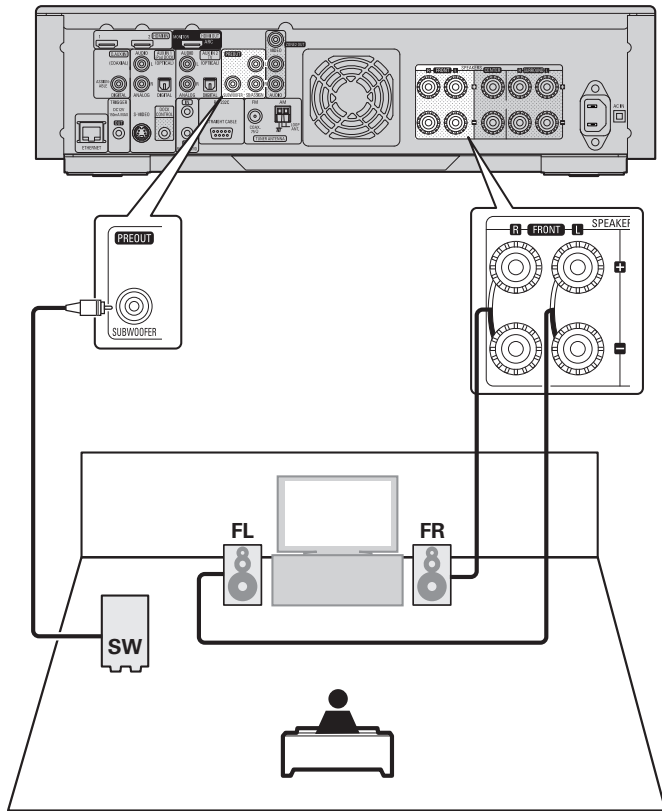

NOTE

- Connect so that the speaker cable core wires do not protrude from the speaker terminal. The protection circuit may be activated if the core wires touch the rear panel or if the + and - sides touch each other (page 74 "Protection Circuit").
- Never touch the speaker terminals while the power supply is connected. Doing so could result in electric shock.

Speakers

Carefully check the left (L) and right (R) channels and + (red) and - (black) polarities on the speakers being connected to this unit, and be sure to interconnect the channels and polarities correctly.

Connecting the speaker cables

Peel off about 10 mm of sheathing from the tip of the speaker cable, then either twist the core wire tightly or terminate it.

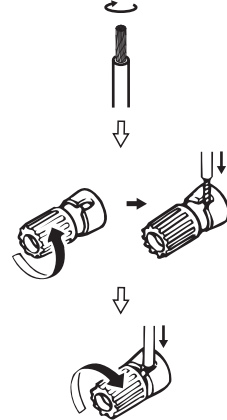

Speaker impedance

Front	4 - 16 Ω
Center	
Surround	

Set Up Speakers

Here we describe how to set up speakers other than 5.1-channel speakers.

For the method of setting up 5.1-channel speakers, see "Simple Version", "4 Set Up Speakers (Audyssey™ Auto Setup)" (page 6).

First install and connect the speakers to this unit.

1 Connect the setup microphone.

The following screen is displayed.

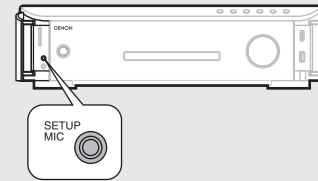

2 Select "Speaker Assign" and then press ENTER.

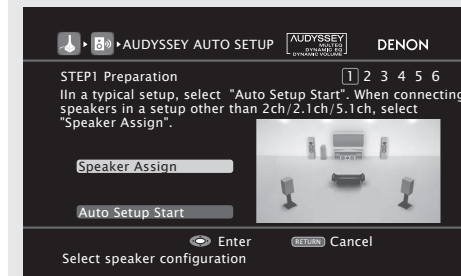

3 Select the configuration of the connected speakers, and then press ENTER.

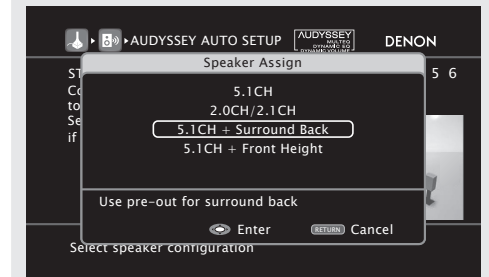

- 5.1CH** Connect 5.1-channel speakers.
- 2.0CH/2.1CH** Connect the front speakers and subwoofer only.
- 5.1CH + Surround Back** Connect the surround back speakers to the PRE OUT connectors.
- 5.1CH + Front Height** Connect the front height speakers to the PRE OUT connectors.

4 Select "Auto Setup Start" and then press ENTER. Proceed to page 7 "STEP1 Preparation" Step 4.

NOTE

- The "FIRST SETUP" screen is displayed only when the power is first turned on after purchase.
- After performing Audyssey Auto Setup, do not change the speaker connections or subwoofer volume. In event of a change, perform Audyssey Auto Setup again.



Move the cursor (Up/Down/Left/Right)



Confirm the setting

RETURN



Return to previous menu

Playback (Advanced)

Advanced Operation

Playback (Basic) (👉 page 18)

Basic Operation (👉 page 28)

Surround Mode (👉 page 31)

❑ Looking for Specific Sections Using the Search Modes (👉 page 37)

❑ Setting Locations to Play Back Again (Marker Function) (👉 page 38)

❑ HDMI Control Function (👉 page 39)

❑ One Touch Play Function (👉 page 39)

❑ Sleep Timer Function (👉 page 40)

❑ Various Memory Functions (👉 page 40)

Looking for Specific Sections Using the Search Modes



1 During playback, press SEARCH, and then search mode.

The search mode setting bar is displayed at the top of the screen.

- The search mode changes each time the button is pressed.

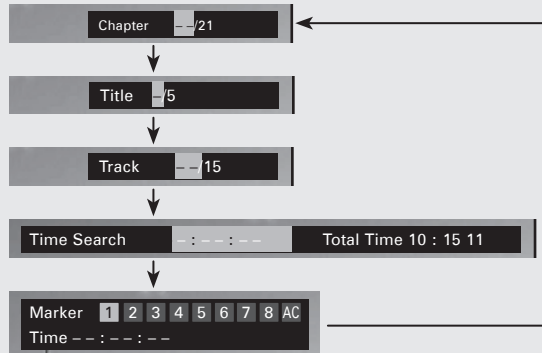

[Content compatible with Search mode]

	Contents		
Search mode			
Chapter search	✓		
Title search	✓		
Track search		✓	✓
Time search	✓	✓	
Marker search *	✓		

* About Marker Search

Plays back from your selected marker number.

You will need to set the marker function before using marker search.



When the entry mode for chapter/title/track search continues for about 5 seconds with no operation, it is cancelled.

2 Conducting search condition entry or setting on the search mode setting bar.

Search specified location on completion of entry.

- 0 - 9, +10** Number entry
- ENTER** Finalizes number
- ◀ ▶** Marker number selection
- ENTER** Finalizes the marker number or plays back
- CLEAR** Marker number cancel



- Entering numbers
 Entering 3 **3, ENTER ***
 Entering 26 **2, 6, ENTER *** or **+10, +10, 6**
 Entering 138 **1, 3, 8, ENTER ***

* Depending on number of recorded songs or chapters, you don't need to use **ENTER**.

• Time search corresponds with title and track playback time. It is not compatible chapter playback time.

NOTE

- Search mode does not operate during random playback. Use **◀◀ ▶▶** to cue.
- Search mode may not operate depending on the disc.

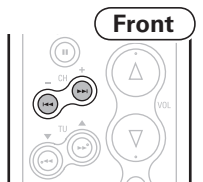

Video



Audio



Photo

Advanced Operation

Setting Locations to Play Back Again (Marker Function)



You can attach a marker to a location you want to view or hear again, so that playback begins at that location.

1 During playback, press **SEARCH** until “Marker” is displayed on the screen.

The search mode setting bar is displayed at the top of the screen.



2 Use **◀▶** to select the number.



- Numbers you have already set will be displayed as ✓.

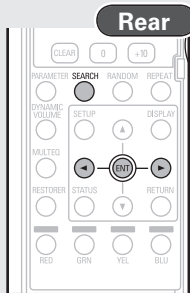

3 Press **ENTER** at the location you want to memorize.

The location is registered for the selected marker number.

- The elapsed playing time at the set location is displayed.

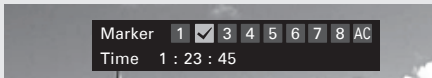

To Play Back Memorized Locations

Use **◀▶** to select the marker number, then press **ENTER**.

To Erase Markers

Select the number you want to erase, and then press **CLEAR**.

To Erase All Markers

Select “AC” and press **ENTER**.

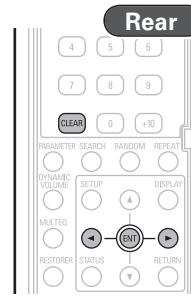

NOTE

- Subtitles may not appear depending on the locations you have memorized.
- The markers you have set will be erased if you turn the power to standby or eject the disc.
- The marker function does not operate across titles.



Convenient Functions

HDMI Control Function

When you make an HDMI connection with a TV compatible with this unit and HDMI control functions, you can perform the following operations by setting the HDMI control function of each device.

The unit power off can be linked to the TV power off step.

When you set "Output audio from amp" in the TV audio output setup operation, you can switch the amp power on.

You can switch audio output devices with a TV operation.

You can adjust the unit volume in the TV volume adjustment operation.

You can switch the unit input source through linkage to TV input switching.

When playing the player, the unit input function switches to the function of that player.

NOTE

- When "HDMI Control" is set to "ON", it consumes more standby power.
- The HDMI control function controls operations of a TV that is compatible with the HDMI control function. Make sure that the TV and HDMI are connected when you perform HDMI control.
- Some functions may not operate depending on the connected TV. Check the owner's manual of each device for details beforehand.
- When "HDMI Setup" – "HDMI Control" – "Power Off Control" on the GUI menu is set to "OFF" (☞ page 55), this unit is not set to standby even if the connected device is in the standby mode.
- When connection changes are implemented, such as adding connections to HDMI devices, linked operations may be initialized. In this case, you will need to reconfigure the settings.

1 Set the HDMI output connector corresponding with the HDMI control function.

On the GUI menu, set "Manual Setup" – "HDMI Setup" – "HDMI Control" (☞ page 55).

2 Turn the power on for all the equipment connected by HDMI cable.

3 Set the HDMI control function for all equipment connected by HDMI cable.

Set "HDMI Control" – "Control" (☞ page 55) to "ON".

- Please consult the operating instructions for the connected equipment to check the settings.
- Carry out steps 1 and 2 should any of the equipment be unplugged.

4 Switch the television input to the HDMI input connected to this unit.

5 Switch the unit input to the HDMI input source and check if the picture from the player is ok.

6 When you turn the TV's power to standby, check that the power of this unit also goes to standby.



If the HDMI control function does not operate properly, check the following points.

- Is the TV compatible with the HDMI control function?
- Is the "HDMI Control" – "Control" (☞ page 55) set to "ON"?
- Is the "Power Off Control" (☞ page 55) set to "ON"?
- Are the HDMI control function settings of all equipment correct? (Step 3)

One Touch Play Function

When this unit is in standby mode and contains a disc, the following sequence of playback operations can be performed automatically simply by pressing **ONE TOUCH PLAY**.

- This unit and TV turn on.
- This unit's input source switches to "BD/SD".
- The TV input switches to this unit's input.
- Disc playback starts.

Setting Requirements

- To use this function, connect this unit and the TV with an HDMI cable and turn on the HDMI control function on both devices.
- Set "Manual Setup" – "HDMI Setup" – "HDMI Control" (☞ page 55) on the GUI menu on this unit to "ON".

Press **ONE TOUCH PLAY**.

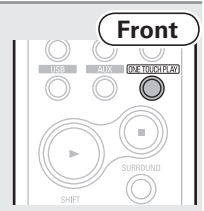

NOTE

The One touch play function will not operate if another device is connected between this unit and the TV. Connect this unit directly to the TV.

Convenient Functions

Sleep Timer Function

The power automatically goes into standby once the set time has elapsed.

This is convenient for playing sources while going to sleep.

Press **SLEEP** and display the time you want to set.

The **SLEEP** indicator on the display lights.

- The time switches as shown below each time **SLEEP** is pressed.

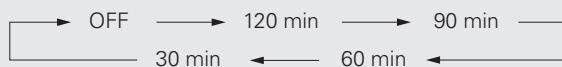
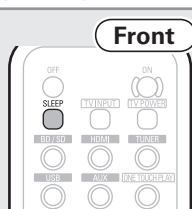

To Cancel the Sleep Timer

Press **SLEEP** to set "OFF".

The **SLEEP** indicator on the display turns off.

NOTE

- If the sleep timer is activated while ZONE2 is in operation, the ZONE2 power switches to OFF along with the MAIN ZONE power.
- The sleep timer setting is canceled if this unit's power is set to standby or turned off.

Various Memory Functions**Personal Memory Plus Function**

This function sets the settings (input mode, surround mode, MultEQ®, Dynamic EQ™, Dynamic Volume™, audio delay etc.) last selected for the individual input sources.

Last Function Memory

This function stores the settings which were made before going into the standby mode.

When the power is turned back on, the settings are restored.

Playback (Multi-zone Function) in ZONE2 (Separate Room)

- You can operate this unit so as to enjoy audio and video in a room (ZONE2) other than the MAIN ZONE (room where the unit is located).
- You can simultaneously play back the same source in both the MAIN ZONE and ZONE2. You can also play back separate sources in the MAIN ZONE and ZONE2.

Multi-zone Connections

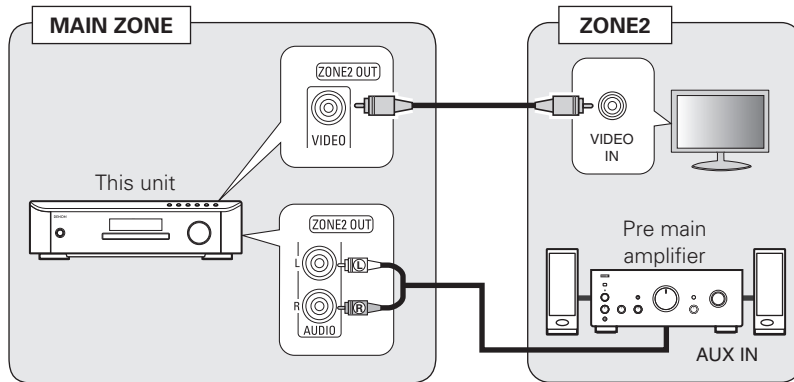

- See “REMOTE CONTROL Jacks” (page 17) for connection information concerning remote control operation in ZONE2.

Audio and video Signals which can be Output in ZONE2

Audio

- Audio from a disc or SD memory card played back on this unit
A multichannel source is converted to a 2-channel downmix signal and output.
- Analog audio input to this unit
- Audio of a device connected to the USB port
- Control dock for iPod (analog audio)

Video

- Video from a disc or SD memory card played back on this unit
- Video input to this unit from a Control dock for iPod



We recommend using high quality pin-plug cables for audio and video connections in order to prevent noise.

NOTE

- Audio and video input to this unit via HDMI is not output.
- The GUI menu screen is not output.
- DENON control dock for iPod ASD-11R switches to Browse Mode and cannot be operated.
- The following media and sources cannot be played back simultaneously in the MAIN ZONE and ZONE2.
 - Disc (BD/DVD/CD) and SD memory card
 - FM and AM

Playback

1 Turn on the pre main amplifier for ZONE2.

2 Switch **DEVICE SELECT** to “ZONE2”.

The remote control unit switches to the operating mode for ZONE2.

3 Press **ON** to turn on the ZONE2 power.

The **Z2** indicator on the display lights.

- Also press input source select button when in standby mode, the power turns on.
- When **OFF** is pressed, ZONE2 turns off.

NOTE

When ZONE2 is powered on, the HDMI video resolution in the MAIN ZONE switches automatically according to the input signal. When this happens, it is not possible to switch to a different video resolution, even by pressing **RESOLUTION**.

4 Press input source select button.

The audio/video signal of the selected source is output to ZONE2.

- To switch the source output to ZONE2 to the source playing back at the MAIN ZONE, press **SOURCE SELECT**.

5 Adjust the volume of the pre main amplifier for ZONE2.

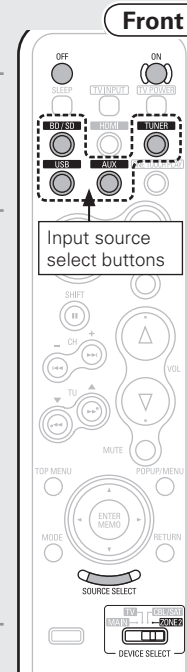

How to Make Detailed Settings

Menu Map

The GUI menu consists of a "BD/DVD SETUP" for performing video-related settings, and an "AMP/SPK SETUP" for audio-related settings. The "BD/DVD SETUP" is displayed only when the input source is "BD/SD".

For the method of GUI menu operation, see page 43.

BD/DVD SETUP



Language Setup (page 44)

Set the language used for playback dialogs, subtitles, and menus.

- Dialog
- Subtitle
- Disc Menus



Ratings (page 45)

Set Blu-ray Disc or DVD parental lock.

- Password
- Rating Country Code
- BD Rating Level
- DVD Rating Level



Display Setup (page 46)

Set display-related items.

- Still Mode
- Slide Show Time
- Captions



Video Setup (page 44)

Set the video output signal according to the connected TV.

- TV Aspect
- Deep Color
- Progressive Mode
- Auto Format



Network Setup (page 45)

Set to connect to the Internet.

- DHCP
- Proxy
- IP Address
- MAC Address



Other Setup (page 46)

Set other items.

- Disc Layer
- Information
- BD Data Utility
- Firmware Update

AMP/SPK SETUP



Source Select (page 47)

Use this to make settings related to playing input sources.

- Input Mode
- Decode Mode
- Rename
- Auto Preset
- Preset Name



Auto Setup (page 52)

Makes the optimum speaker settings and corrects for the acoustic characteristics of the room.

- Audyssey Auto Setup
- Parameter Check



Information (page 57)

Show information about receiver settings, input signals, etc.

- Status
- Audio Input Signal
- HDMI Information
- Auto Surround Mode
- Preset Channel



Audio Adjust (page 48)

Adjust various audio parameters.

- Surround Parameters
- Tone
- Audyssey Settings
- Audio Delay



Manual Setup (page 53)

Use this to make various types of detailed settings.

- Speaker Setup
- HDMI Setup
- Audio Setup
- Option Setup
- GUI Language

GUI Menu Operation

1 Press SETUP and select the menu for the settings you want to make.
The GUI menu is displayed on the TV screen.

• The menus that can be displayed differ depending on the selected input source.

❑ **When the input source is "BD/SD"**



❑ **When the input source is not "BD/SD"**



2 Press Δ ∇ \triangleright to select the menu to be set or operated.

• To return to the previous item, press \triangleleft or RETURN.

3 Press ENTER to enter the setting.

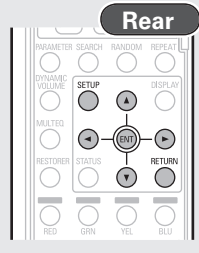

❑ **Exiting the GUI Menu**

Press **SETUP** until the GUI menu disappears.

NOTE

You must use the GUI menu to make settings or operate while a disc or SD memory card is not inserted. In cases in which the resume function is activated, you may not make correct settings.

Example of GUI Mark at Title

Items for which this mark is indicated at the title can be operated from the GUI.
We recommend performing such operations from the GUI.



Manual Setup



Examples of GUI Menu Screen Displays

Typical examples are described below.

[Example 1] Menu Selection Screen (Top Menu)

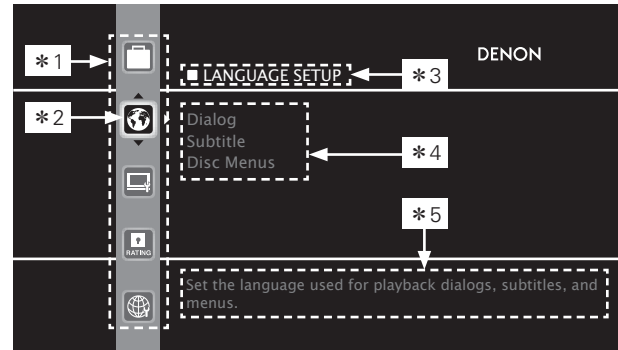

- *1 List of GUI menu setup icons
- *2 Currently selected setup icon
- *3 Currently selected setup item
- *4 List of currently selected setup subcategory
- *5 Guide text for the currently selected setup item

Press ∇ to select and then press \triangleright .
(Or press ENTER.)

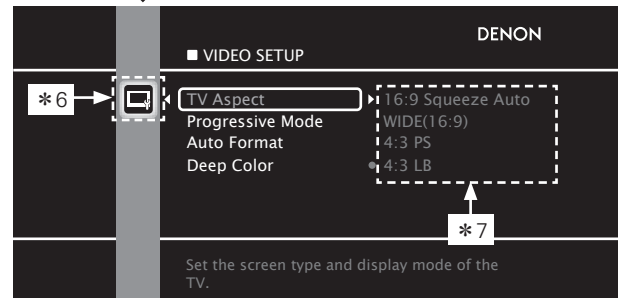

- *6 Selected setup icon
- *7 Options of the selected setup item

❑ **Icon**

Switch the selected item (Use Δ or ENTER to switch.)

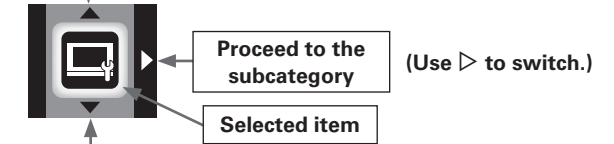

Switch the selected item (Use ∇ to switch.)

❑ **List**

Returns to the previous item (Use \triangleleft or RETURN to switch.)

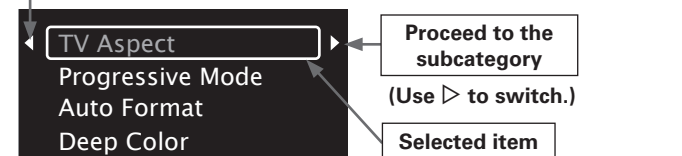

• Switch the selected item using Δ ∇ .



Text colors of selected items of the GUI menu are as follows:

- White : These items can be selected.
- Gray : These items cannot be selected.

Getting Started
Simple Version
Connections
Playback (Basic)
Settings
Playback (Advanced)
Multi-zone
GUI
Remote Control
Part Names
Other Information
Troubleshooting
Spec.
Index





Language Setup



Default settings are underlined.

Set the language used for playback dialogs, subtitles, and menus.

Setting items	Setting details
Dialog Set the dialog language used to play Blu-ray Discs or DVDs.	<p>Original : Plays the dialog selected at the top in the language menu stored in the disc.</p> <p>English / French / Spanish / German / Japanese / Italian / Swedish / Dutch / Russian / Chinese / Korean / Danish / Finnish / Norwegian / Icelandic / Hungarian / Romanian / Turkish / Greek / Irish / Portuguese / Polish / Czech / Slovak / Bulgarian</p> <p>Others : Enter the language code. Refer to "Language Code List" (page 70), use 0 – 9 to input the language code, then press ENTER to set.</p> 
Subtitle Set the subtitle language used to play Blu-ray Discs or DVDs.	<p>Off : Do not display subtitles.</p> <p>English / French / Spanish / German / Japanese / Italian / Swedish / Dutch / Russian / Chinese / Korean / Danish / Finnish / Norwegian / Icelandic / Hungarian / Romanian / Turkish / Greek / Irish / Portuguese / Polish / Czech / Slovak / Bulgarian</p> <p>Others : Enter the language code. Refer to "Language Code List" (page 70), use 0 – 9 to input the language code, then press ENTER to set.</p>
Disc Menus Set the language used for Blu-ray Disc or DVD menus.	<p>English / French / Spanish / German / Japanese / Italian / Swedish / Dutch / Russian / Chinese / Korean / Danish / Finnish / Norwegian / Icelandic / Hungarian / Romanian / Turkish / Greek / Irish / Portuguese / Polish / Czech / Slovak / Bulgarian</p> <p>Others : Enter the language code. Refer to "Language Code List" (page 70), use 0 – 9 to input the language code, then press ENTER to set.</p>

NOTE

The setting may not be active depending on the disc.



Video Setup



Default settings are underlined.

Set the video output signal according to the connected TV.

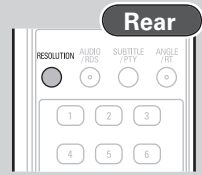
Setting items	Setting details
TV Aspect (Aspect ratio) Set the screen type and display mode of the TV.	<p>16:9 Squeeze Auto : Output to a wide screen TV. For 4:3 video, display in the center of the screen without changing the aspect ratio.</p> <p>WIDE (16:9) : Output to a wide screen TV.</p> <p>4:3 PS : Output to a 4:3 TV. For wide video, trim the left and right side of the image and display in 4:3 aspect ratio. *1</p> <p>4:3 LB : Output to a 4:3 TV. Display all of the wide video. *2</p>
Progressive Mode Set an appropriate progressive conversion mode for the source video material.	<p>Auto : Detect the type of video material and automatically switch the mode. Normally, this setting is used.</p> <p>Video1 : Select when video appears unnatural in Auto or Video2 mode.</p> <p>Video2 : Select when video appears unnatural in Auto or Video1 mode.</p>
Auto Format Set the content of HDMI video output resolution item "Auto" (page 13) with RESOLUTION .	<p>Max Res. : Output data using the maximum resolution that can be handled by the connected TV.</p> <p>Panel Res. : Output data using the maximum resolution of the panel of the connected TV.</p> 
Deep Color Extends the degree of color depth in the HDMI video signal (number of colors used), to play back more natural colors without color fringing.	<p>Auto : Deep Color is automatically output when the connected HDMI device supports Deep Color.</p> <p>Off : Do not output Deep Color.</p>

*1 Depending on the video content, even though you set the 4:3 PS (Pan Scan), the content may be output in 4:3 LB (Letter Box).

*2 Only valid for content recorded in 480i/576i.



Display the menu
Cancel the menu



Move the cursor
(Up/Down/Left/Right)



Confirm the setting

RETURN



Return to previous menu



Ratings



Default settings are underlined.

Set Blu-ray Disc or DVD parental lock.

Setting items	Setting details
Password Sets the password for changing the parental control level and parental control country code of Blu-ray Disc and DVD.	Change : Change the password. Use 0 – 9 to enter a password and then press ENTER to finalize it. The default setting is "0000". To clear the entered password, press CLEAR .
BD Rating Level Set the parental level for playing Blu-ray Disc.	Level 0 – 254 : Set the age allowed to play back media. Restricts playback of discs with relevant parental control. No Limit : Do not restrict playing of Blu-ray Discs.
DVD Rating Level Set the parental level for playing DVD.	Lock All : Restrict playing of all DVDs. Level1 – 8 : Set the parental level for playing DVD. No Limit : Do not restrict playing of DVDs.
Rating Country Code Sets the standard country parental control. Apply the parental level of the set country.	Argentina / Australia / Austria / Belgium / Brazil / Canada / Chile / China / Denmark / Finland / France / Germany / Hong Kong / India / Indonesia / Italy / Japan / Korea, Republic of / Malaysia / Mexico / Netherlands / New Zealand / Norway / Pakistan / Philippines / Portugal / Russian Federation / Singapore / Spain / Switzerland / Sweden / Taiwan / Thailand / United Kingdom / <u>United States</u> / Colombia / Greece / Ireland / Luxembourg / Poland Others : Inputs the country code. Refer to "Country Code List" (page 71) and, with the virtual keyboard, use 0 – 9 and ENTER to input the country code. To clear the entered country code, press CLEAR .



Network Setup



Default settings are underlined>.

Set to connect to the Internet.

You can use a disc which offers BD-LIVE function by connecting the unit to the Internet (page 21).

To obtain update support for this unit, you can download the latest firmware from our website.

Make a network connect beforehand according to "Connecting to the Network" (page 16).

Setting items	Setting details
DHCP Set how to perform network configuration, automatically or manually.	[On] : Automatically configure the network by the DHCP function. [Off] : When connecting to a network, which does not have the DHCP function, manually configure the following network settings. For the details of the settings, confirm with the provider or network administrator. Use 0 – 9 to enter a value and then press ENTER to finalize it.
Proxy Set to connect to the Internet via a proxy server.	[Off] : Do not use a proxy server. [On (Address)] : Set to connect to the Internet via a proxy server. Use the address to specify the proxy server. Use 0 – 9 to enter the address and then press ENTER to finalize it. [On (Name)] : Set to connect to the Internet via a proxy server. Specify the proxy server using the domain name. Input the domain name with the virtual keyboard, using $\Delta \nabla \triangleleft \triangleright$ and ENTER .
IP Address This unit's IP address is displayed.	If the IP address cannot be obtained or is not set, "..." is displayed. In that case, check that the connection and network configuration is correct.
MAC Address Displays the MAC address of this unit.	

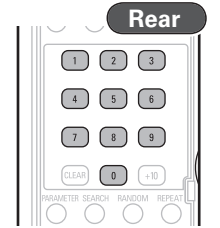

Remote control operation buttons



Display the menu
Cancel the menu



Move the cursor
(Up/Down/Left/Right)



Confirm the setting

RETURN



Return to previous menu

- Getting Started
- Simple Version
- Connections
- Playback (Basic)
- Settings
- Playback (Advanced)
- Multi-Zone
- GUI
- Remote Control
- Part Names
- Other Information
- Troubleshooting
- Spec.
- Index



Display Setup



Default settings are underlined.

Set display-related items.

Setting items	Setting details
Still Mode Set image quality during pause.	<u>Automatic</u> : Display automatically using “Field” or “Frame” per the still image information. Field : Set when there is a blurred image when “Automatic” image display is set. Frame : Set to display non moving images in high resolution.
Slide Show Time Sets the display time of JPEG files.	<u>3 – 5 – 100sec</u> : This sets the display time per frame of a JPEG file during slideshow playback.
Captions This setting output a subtitles signal to a closed caption decoder (sold separately).	<u>On</u> : Output the closed caption (subtitle) signal. Off : Do not output the closed caption (subtitle) signal.



Other Setup



Default settings are underlined.

Set other items.

Setting items	Setting details
Disc Layer Sets the layer to play back in a hybrid disc.	<u>BD</u> : Plays back the Blu-ray Disc layer. DVD : Plays back the DVD layer.
Information Displays the license for the IPA font used by this product.	[Font License] Japanese (Original) : Displays in Japanese. The font used in this product’s GUI menu screen conforms to IPA font specifications. See the following URL for the IPA font license agreement. http://ipafont.ipa.go.jp/enduser_license.html
BD Data Utility Erases data on SD memory card, and initializes cards.	[BD Data Erase] : Erases both internal memory and SD memory card storage. • No • Yes [Initialize SD Card] : Initialize the SD memory card to be used for the Bonus View and BD-LIVE function. • No • Yes

Setting items	Setting details
BD Data Utility (Continued)	NOTE <ul style="list-style-type: none"> • Insert or remove a SD memory card while the power is in standby. If you insert a SD memory card while the power is ON, the SD memory card may not be read. • The SD memory card used for the Bonus View function must have a capacity of 1 GB or greater. Also the SD memory card must be initialized on this unit. • This operation will delete all the data. Do not perform this operation when an SD memory card containing MP3 or JPEG data is inserted.
Firmware Update Update the firmware of the unit via the Internet.	Check for Update : Check if the latest firmware exists. You can also check approximately how long it will take to complete an update. Start : Starts firmware update. When updating starts, the power indicator lights red and the GUI screen is shut down. During update, a rough remaining time is indicated on the display. When updating is complete the power indicator lights green and normal status is resumed.
NOTE “Firmware Update” cannot be selected when there is a disc in the disc tray.	Cautions on “Firmware Update” <ul style="list-style-type: none"> • In order to use this functions, you must have the correct system requirements and settings for a broadband Internet connection (page 16). • Do not turn off the power until updating is completed. • Information regarding the “Firmware Update” function will be announced on the DENON web site each time related plans are defined. • Even with a broadband connection to the Internet, approximately 1 hour is required for the updating procedure to be completed. • Once updating starts, normal operations on this unit cannot be performed until updating is completed. In addition, the unit’s GUI menu settings may be initialized. • In the event of an update error during update or upgrade, turn the power of this unit off and then on again. “Update retry” appears on the display and update restarts from the point at which update failed. If the error continues despite this, check the network environment.

SETUP



Display the menu
Cancel the menu



Move the cursor
(Up/Down/Left/Right)



Confirm the setting

RETURN



Return to previous menu



Source Select



Perform settings related to input source playback.

- You do not have to change the settings to use the unit. Make settings when needed.

Items that can be Set with the Source Select Procedure

Input Mode page 47

Decode Mode page 47

Rename page 47

Auto Preset page 48

Preset Name page 48

Important Information

About the Display of Input Sources

In this section, the configurable input sources for each item are shown as follows.

BD/SD **HDMI1** **HDMI2** **HDMI3** **FM** **AM** **USB** **AUX1** **AUX2**

To perform the following settings, select the input source and then select the items you want to set. **[To select the input source]** Use Δ / ∇ to select the input source and press \triangleright .

Input Mode



Default settings are underlined.

The input modes available for selection may vary depending on the input source.

Setting items	Setting details
Input Mode Set the audio input modes for the AUX1/2.	Auto : Automatically detect input signal and perform playback. Digital : Play only signals from digital input. Analog : Play only signals from analog input.
AUX1 AUX2	When digital signals are properly input, the [DIG.] indicator lights on the display. If the [DIG.] indicator does not light, check the digital input connector assignment and the connections.

Decode Mode



Default settings are underlined.

Set the decode mode for input source.

Setting items	Setting details
Decode Mode Set the decode mode for input source.	Auto : Detect type of digital input signal and decode and play automatically. PCM : Decode and play only PCM input signals. DTS : Decode and play only DTS input signals.
BD/SD HDMI1 HDMI2 HDMI3 AUX1 AUX2	Normally set this mode to "Auto". Set "PCM" and "DTS" when inputting the corresponding input signal.

Rename



Change the display name of the selected input source.

Setting items	Setting details
Rename • Change the display name of the selected input source.	<ol style="list-style-type: none"> Press \triangleright or ENTER. Press \triangleleft/\triangleright, align the cursor to the icon to be changed, and press ENTER. <ul style="list-style-type: none"> At this time, the input source name is also automatically changed. To change the input source name, press Δ/∇ to change the characters, and press ENTER. <ul style="list-style-type: none"> Up to eight characters can be input. The input character type can be switched by pressing SEARCH while the display name is being changed. The types of characters that can be input are as shown below. Repeat steps 2 and 3 to change the display name.
Default Reset all settings to factory default.	No Yes

BD/SD **HDMI1** **HDMI2**
HDMI3 **FM** **AM**
USB **AUX1** **AUX2**

- When the input source is **HDMI1**, **HDMI2**, **HDMI3**, **AUX1**, or **AUX2**, you can change the displayed icon.

[Upper case characters] ABCDEFGHIJKLMNOPQRSTUVWXYZ
[Lower case characters] abcdefghijklmnopqrstuvwxyz
[Symbols] ! # % & ' () * + , - . / : ; < = " > ? @ [\]
[Numbers] 0123456789 (Space)

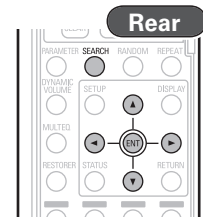

Remote control operation buttons

SETUP



Display the menu
Cancel the menu



Move the cursor
(Up/Down/Left/Right)



Confirm the setting

RETURN



Return to previous menu

Source Select

Auto Preset GUI

Use the auto preset function to program radio stations.

Setting items	Setting details
Start Start the auto preset process. <div style="border: 1px solid black; padding: 2px; display: inline-block;">FM</div>	 If an FM station cannot be preset automatically, select the desired station by tuning it in manually, then preset it manually. <div style="border: 1px solid black; padding: 2px; display: inline-block; background-color: #f0f0f0;">NOTE</div> If "Auto Preset" is performed after performing "Manual Preset" (page 27), the "Manual Preset" settings will be overwritten.

Preset Name GUI

Assign name to a preset memory.

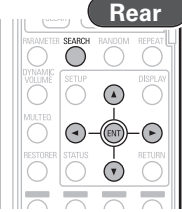
Setting items	Setting details
A1 – G8 Select the preset channel. <div style="display: flex; gap: 10px;"> <div style="border: 1px solid black; padding: 2px; display: inline-block;">FM</div> <div style="border: 1px solid black; padding: 2px; display: inline-block;">AM</div> </div>	<ol style="list-style-type: none"> Press ▷ or ENTER. Use ◀▶ to set the cursor to the character you want to change. Use △▽ to change the character, then press ENTER. <ul style="list-style-type: none"> Up to eight characters can be input. The input character type can be switched by pressing SEARCH while the display name is being changed. The types of characters that can be input are as shown below. <div style="border: 1px solid black; padding: 5px; margin-top: 10px;"> <p>[Upper case characters] ABCDEFGHIJKLMNOPQRSTUVWXYZ</p> <p>[Lower case characters] abcdefghijklmnopqrstuvwxyz</p> <p>[Symbols] ! # % & ' () * + , - . / : ; < = " > ? @ [\]</p> <p>[Numbers] 0 1 2 3 4 5 6 7 8 9 (Space)</p> </div>  Repeat steps 2 and 3 to change the display name.
Default Reset all settings to factory default.	No Yes



Audio Adjust GUI

The sound being played in the surround mode can be adjusted to your liking. The items (parameters) that can be adjusted depend on the signal being input and the currently set surround mode. For details on the adjustable parameters, see "Surround Modes and Audio Adjust" (page 68).

Items that can be Set with the Audio Adjust Procedure

Surround Parameters  page 48

Tone  page 50

Audyssey Settings  page 51

Audio Delay  page 52

Surround Parameters GUI

Default settings are underlined.

Adjust surround sound parameters. It may not be possible to set this item depending on the input signal.

Setting items	Setting details
DOLBY VS Mode Select the Dolby Virtual Speaker mode.	REF : This is the standard Dolby Virtual Speaker mode. WIDE : This mode creates the sense of a wider sound.
Mode Set the play modes for the different surround modes.	<input type="checkbox"/> In the PLIIx or PLII Mode Cinema : Surround sound mode optimized for movie sources. Music : Surround sound mode optimized for music sources. Game : Surround sound mode optimized for games. Pro Logic : Dolby Pro Logic playback mode (PLII mode only). <input type="checkbox"/> In the PLIIz Mode Height : Dolby PLIIz Height playback mode. <input type="checkbox"/> In the DTS NEO:6 Mode Cinema : Surround sound mode optimized for movie sources. Music : Surround sound mode optimized for music sources.
	 <ul style="list-style-type: none"> When "Surround Parameters" – "Front Height" (page 49) is set to "ON", the "Height" mode is set automatically. The "Music" mode is also effective for movie sources including a lot of stereo music.



Display the menu
Cancel the menu



Move the cursor
(Up/Down/Left/Right)









Confirm the setting

RETURN



Return to previous menu

Setting items	Setting details
Cinema EQ Soften the treble range of movie soundtracks for better understanding.	ON OFF
DRC Compress dynamic range (difference between loud and soft sounds).	OFF : Dynamic range compression always off. Low / Middle / High : These set the compression level. Auto : Automatic dynamic range compression on/off control according to source. This can be set in the Dolby TrueHD mode.
D.COMP Compress dynamic range (difference between loud and soft sounds).	OFF : Turn dynamic range compression off. Low / Middle / High : These set the compression level.
LFE Adjust the low-frequency effects level (LFE).	-10dB - 0dB  For proper playback of the different sources, we recommend setting to the values below. • Dolby Digital sources : "0dB" • DTS movie sources : "0dB" • DTS music sources : "-10dB"
Center Image Assign center channel signal to front left and right channels for wider sound.	0.0 - 1.0 (0.3)  Only DTS NEO:6 MUSIC mode
Panorama Assign front L/R signal also to surround channels for wider sound.	OFF ON  Only Dolby PLII/PLIIX MUSIC mode
Dimension Shift sound image center to front or rear to adjust playback balance.	0 - 6 (3)  Only Dolby PLII/PLIIX MUSIC mode
Center Width Assign center channel signal to front left and right channels for wider sound.	0 - 7 (3)  Only Dolby PLII/PLIIX MUSIC mode

Setting items	Setting details
Front Height Set the Dolby PLIIZ Height mode to ON or OFF. When "Speaker Assign" is set to "5.1CH + Front Height", you can stop the front height speaker output.	ON : Audio is output from the front height speaker. OFF : Audio is not output from the front height speaker. NOTE • "Front Height" is not displayed with the settings listed below. • When the "Speaker Assign" setting (🔧 page 53) is set to something other than "5.1CH + Front Height". • When the "Speaker Configuration" - "Front Height" setting (🔧 page 54) is set to "None". • "Front Height" cannot be set if the HD Audio source being played includes a front height channel. In this case, the Front height channel is played back without decoding in PLIIZ mode, using the input signal.
AFDM (Auto flag detect mode) Detect the source's surround back channel signal and set the optimum surround mode automatically.	ON OFF [Example] Playing Dolby Digital software (with EX flag) • When "AFDM" is set to "ON", the surround mode is automatically set to the DOLBY D + PLIIX C mode. • To play in the DOLBY DIGITAL EX mode, set "AFDM" to "OFF" and "Surround Back" to "MTRX ON".  Some Dolby Digital EX sources do not include EX flags. If the playback mode does not switch automatically even when "AFDM" is set to "ON", set "Surround Back" to "MTRX ON" or "PLIIX CINEMA". NOTE If the setting in "Speaker Configuration" - "Surround Back" (🔧 page 54) is "None", "Surround Back" is not displayed.

Remote control operation buttons



Display the menu
Cancel the menu



Move the cursor
(Up/Down/Left/Right)



Confirm the setting

RETURN



Return to previous menu

Getting Started
Simple Version
Connections
Playback (Basic)
Settings
Playback (Advanced)
Multi-zone
GUI
Remote Control
Part Names
Other Information
Troubleshooting
Spec.
Index



Audio Adjust

Setting items	Setting details
<p>Surround Back Sets the method of generating of the surround back channel.</p>	<p><input type="checkbox"/> For 2-channel Sources OFF : No signal is played from the surround back channels. ON : The surround back channel is used.</p> <p><input type="checkbox"/> For Multi-channel Sources Set the decoding method for the surround back channel. DSCRT ON : Play the surround back signals included in the 7.1-channel source. MTRX ON : Generate and play the surround back signals from the surround channel signals. ES MTRX*1 : Generate and play the surround back signals from the surround channel signals of the DTS source. ES DSCRT*2 : Play the surround back signals included in the 6.1-channel DTS source. PLIIx CINEMA*3 : Generate and play the surround back signals by decoding the signals in the Dolby Pro Logic IIx Cinema mode. PLIIx MUSIC : Generate and play the surround back signals by decoding the signals in the Dolby Pro Logic IIx Music mode. OFF : Do not play the surround back channel.</p> <p>*1 This can be selected when playing DTS sources. *2 This can be selected when playing DTS sources including a signal to identify discrete 6.1-channel signals. *3 This can be selected when "Speaker Configuration" – "Surround Back" (page 54) is set to "2spkr".</p> <p> If the source being played contains a surround back signal, the decoder type is automatically selected by the AFDM function. Set "AFDM" to "OFF" to switch to your preferred decoder.</p> <p>NOTE If the setting in "Speaker Configuration" – "Surround Back" (page 54) is "None", "Surround Back" is not displayed.</p>
<p>Default Restore all the surround parameter settings to their defaults.</p>	<p>Yes No</p>

Tone



Default settings are underlined.

Adjust the tonal quality of the sound.

Setting items	Setting details
<p>Tone Control Set the tone control function to ON and OFF.</p>	<p>ON : Allow tone adjustment (bass, treble). OFF : Playback without tone adjustment.</p> <p> "Tone Control" can be set when "Dynamic EQ" (page 51) is set to "OFF".</p>
<p>Bass Adjust low frequency range (bass).</p>	<p>-6dB – +6dB</p> <p> "Bass" can be set when "Tone Control" is set to "ON".</p>
<p>Treble Adjust high frequency range (treble).</p>	<p>-6dB – +6dB</p> <p> "Treble" can be set when "Tone Control" is set to "ON".</p>

SETUP



Display the menu
Cancel the menu



Move the cursor
(Up/Down/Left/Right)



Confirm the setting

RETURN



Return to previous menu

Audyssey Settings



Default settings are underlined.

Set MultEQ®, Dynamic EQ™ and Dynamic Volume™. These can be selected after Audyssey Auto Setup has been performed. For additional information on Audyssey technology, please see page 72.

NOTE

If you have not performed Auto Setup, or if you change the speaker settings after performing Auto Setup, you may not be able to select Dynamic EQ/Dynamic Volume, and “Run Audyssey” may be displayed. In this case, either perform Audyssey Auto Setup over again or perform “Restore” (page 52) to return to the settings after Audyssey Auto Setup was run.

Setting items	Setting details
<p>MultEQ Select one equalizer from three modes. MultEQ corrects both time and frequency response problems in the listening area based on Audyssey Auto Setup calibration. MultEQ is the prerequisite function for Dynamic EQ and Dynamic Volume. If “MultEQ” is set to “OFF” when “Dynamic EQ” or “Dynamic Volume” is set to “ON”, “Dynamic EQ” and “Dynamic Volume” are automatically set to “OFF”.</p>	<p>Audyssey : Optimize the frequency response of all speakers. Audyssey Byp.L/R : Optimize frequency response of speakers except front L and R speakers. Audyssey Flat : Optimize frequency response of all speakers to flat response. OFF : Turn “MultEQ” equalizer off.</p> <p> • “Audyssey”, “Audyssey Byp. L/R” and “Audyssey Flat” can be selected after Audyssey Auto Setup has been performed. “Audyssey” is automatically selected after performing Audyssey Auto Setup. “When “Audyssey”, “Audyssey Byp. L/R” or “Audyssey Flat” is selected, lights.</p> <p>• After running Audyssey Auto Setup, if the Speaker Configuration, Distance, Channel Level, and Crossover Frequency have changed without increasing the number of speakers measured, only lights.</p> <p>• If “Dynamic EQ” or “Dynamic Volume” is set to “ON” when “MultEQ” is set to “OFF”, “MultEQ” is automatically set to “Audyssey”.</p> <p>• You can also press MULTEQ to set this item.</p> <div style="text-align: right;"> <p>Rear</p> </div>
	<p>NOTE When using headphones, “MultEQ” is automatically set to “OFF”.</p>

Setting items	Setting details
<p>Dynamic EQ™ Solve the problem of deteriorating sound quality as volume is decreased by taking into account human perception and room acoustics.</p>	<p>ON : Use Dynamic EQ. OFF : Do not use Dynamic EQ.</p> <p></p> <ul style="list-style-type: none"> • After performing “Audyssey Auto Setup”, the “Dynamic EQ” setting automatically becomes “ON”. • If is displayed when set to “ON”. • When “MultEQ” is set to “OFF”, “Dynamic EQ” is automatically set to “OFF”. • If “Dynamic Volume” is set to “ON”, “Dynamic EQ” is automatically set to “ON”. • When you set “Dynamic EQ” to “ON”, “Tone Control” is switched “OFF”.
<p>Reference Level Offset Audyssey Dynamic EQ is referenced to the standard film mix level. It makes adjustments to maintain the reference response and surround envelopment when the volume is turned down from 0 dB. However, film reference level is not always used in music or other non-film content. Dynamic EQ Reference Level Offset provides three offsets from the film level reference (5 dB, 10 dB, and 15 dB) that can be selected when the mix level of the content is not within the standard.</p>	<p>0dB (Film Ref) : This is the default setting and should be used when listening to movies. 5dB : Select this setting for content that has a very wide dynamic range, such as classical music. 10dB : Select this setting for jazz or other music that has a wider dynamic range. This setting should also be selected for TV content as that is usually mixed at 10 dB below film reference. 15dB : Select this setting for pop/rock music or other program material that is mixed at very high listening levels and has a compressed dynamic range.</p> <p> Setting is enabled when “Dynamic EQ” is “ON”.</p>

Remote control operation buttons



Display the menu
Cancel the menu



Move the cursor
(Up/Down/Left/Right)



Confirm the setting

RETURN





Return to previous menu

- Getting Started
- Simple Version
- Connections
- Playback (Basic)
- Settings
- Playback (Advanced)
- Multi-Zone
- GUI
- Remote Control
- Part Names
- Other Information
- Troubleshooting
- Spec.
- Index

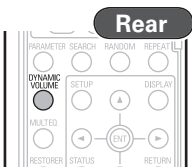

Getting Started
Simple Version
Connections
Playback (Basic)
Settings
Playback (Advanced)
Multi-zone
GUI
Remote Control
Part Names
Other Information
Troubleshooting
Spec.
Index

Audio Adjust

Setting items	Setting details
<p>Dynamic Volume™ Solve the problem of large variations in volume level between TV, movies and other content (between quiet passages and loud passages, etc.) by automatically adjusting to the user's preferred volume setting.</p>	<p>ON : Use "Dynamic Volume". Dynamic Volume effect will be at the level of the "Setting". OFF : Do not use "Dynamic Volume".</p>  <p>  AUDYSSEY MULTIEQ DYN VOL is displayed when set to "ON". </p> <ul style="list-style-type: none"> When "MultEQ" is set to "OFF", "Dynamic Volume" is automatically set to "OFF". You can also press DYNAMIC VOLUME to set this item. <pre> graph LR A[Dynamic EQ : ON / Dynamic Volume : OFF] --> B[Dynamic EQ : OFF / Dynamic Volume : OFF] B --> C[Dynamic EQ : ON / Dynamic Volume : ON] C --> A </pre>
<p>Setting Set "Dynamic Volume" equalizer effect.</p>	<p>Midnight : High setting affects volume the most, causing all sounds to be of equal loudness. Evening : Middle setting prevents loud and soft sounds from being much louder and softer respectively than average sounds. Day : Low setting provides the least adjustments to the loudest and softest of sounds.</p> <p>  "Setting" can be set when "Dynamic Volume" is set to "ON". </p>



Auto Setup



Setting items	Setting details
<p>Audyssey™ Auto Setup Analyzes the acoustic characteristics of the listening point measured with the supplied setup microphone and automatically makes the optimum output settings for each speaker to match the environment of the listening room.</p>	<p>For details, see "Set Up Speakers (Audyssey™ Auto Setup)" (page 6) and "Setting for Speakers Other Than 5.1-channel" (page 34).</p>
<p>Parameter Check Enables you to check the measurement results and equalizer characteristics after Audyssey Auto Setup.</p>	<p>Speaker Config. Check : Check the speaker configuration. Distance Check : Check the distance. Channel Level Check : Check the channel level. Crossover Freq. Check : Check the crossover frequency. EQ Check : Check MultEQ parameters. Restore : Restore auto setup measurement result.</p>

Audio Delay



Default settings are underlined.

While viewing video, manually adjust the time to delay audio output.

Setting details

0ms – 200ms

 Store "Audio Delay" for each input source.



Display the menu
Cancel the menu



Move the cursor
(Up/Down/Left/Right)



Confirm the setting

RETURN



Return to previous menu



Manual Setup



Set when changing Audyssey™ Auto Setup settings, or when changing the audio, video, display or other settings.

- If you change the speaker settings after performing Audyssey Auto Setup, it will not be possible to set MultEQ®, Dynamic EQ™ and Dynamic Volume™ (page 51, 52).
- Can be used without changing the settings. Please set if necessary.

Items that can be Set with the Manual Setup Procedure



Speaker Setup page 53



HDMI Setup page 55



Audio Setup page 56



Option Setup page 56



GUI Language page 57



Speaker Setup



Default settings are underlined>.

Perform this operation when manually setting the speakers, or when the changing the setting content in "FIRST SETUP" (Audyssey Auto Setup).

Setting items	Setting details
<p>Speaker Assign Set the speakers connected to this unit. By performing this setting, you can shorten the automatic detection time for the speakers during "FIRST SETUP" (Audyssey Auto Setup).</p>	<p>5.1CH : Set when using 5.1-channel (Front/Center/Surround/Subwoofer) speakers. 5.1CH / 2.1CH : Set when only using front speakers and a subwoofer. 5.1CH + Surround Back : Set when using the 5.1-channel speaker and surround back speaker. 5.1CH + Front Height : Set when using 5.1-channel speakers and front height speakers.  Connect the surround back speakers or front height speakers to the PRE OUT SURR. BACK connector (page 35).</p>
<p>Speaker Configuration Select speaker configuration and size (bass reproduction capability).</p> <p>NOTE Do not use the outward shape of the speaker to determine selection of a "Large" or "Small" speaker. Instead, use the frequencies set in "Crossover Frequency" (page 55) as the standard for determining bass reproduction capability.</p>	<p>Front : Set the front speaker size. <ul style="list-style-type: none"> • Large : Use a large speaker that can adequately play back low frequencies. • Small : Use a small speaker that has inadequate playback capacity for low frequencies. Center : Set the presence and size of the center speaker. <ul style="list-style-type: none"> • Large : Use a large speaker that can adequately play back low frequencies. • Small : Use a small speaker that has inadequate playback capacity for low frequencies. • None : Select when a center speaker is not connected. Subwoofer : Set the presence of a subwoofer. <ul style="list-style-type: none"> • Yes : Use a subwoofer. • No : Select when a subwoofer is not connected. Surround : Set the presence and size of the surround speakers. <ul style="list-style-type: none"> • Large : Use a large speaker that can adequately play back low frequencies. • Small : Use a small speaker that has inadequate playback capacity for low frequencies. • None : Select when the surround speakers are not connected. </p>

Remote control operation buttons



Display the menu
Cancel the menu



Move the cursor
(Up/Down/Left/Right)



Confirm the setting

RETURN



Return to previous menu

Getting Started

Simple Version

Connections

Playback (Basic)

Settings

Playback (Advanced)

Multi-zone

GUI

Remote Control

Part Names

Other Information



Troubleshooting



Spec.

Index



Manual Setup

Setting items	Setting details
Speaker Configuration (Continued)	<p>Surround Back : Set the presence, size and number of surround back speakers.</p> <ul style="list-style-type: none"> • Large : Use a large speaker that can adequately play back low frequencies. • Small : Use a small speaker that has inadequate playback capacity for low frequencies. • None : Select when the surround back speakers are not connected. <p>• 2spkr : Use two surround back speakers.</p> <p>• 1spkr : Use only one surround back speaker. When you select this setting, connect the surround back speaker to the left (L) channel.</p> <p> Even when the "Surround Back" setting is other than "None", sound may not be emitted from the surround back speaker, depending on the playback source. In this case, make "Surround Parameters" – "Surround Back" setting other than "OFF" (page 50).</p> <p>NOTE When the "Speaker Assign" setting (page 53) is other than "5.1CH + Surround Back", you cannot make the "Surround Back" setting.</p> <p>Front Height : Set the presence and size of the front height speakers.</p> <ul style="list-style-type: none"> • Large : Use a large speaker that can adequately play back low frequencies. • Small : Use a small speaker that has inadequate playback capacity for low frequencies. • None : Select when the front height speakers are not connected. <p>NOTE When the "Speaker Assign" setting (page 53) is other than "5.1CH + Front Height", you cannot make the "Front Height" setting.</p>
Bass Setting Set subwoofer and LFE signal range playback.	<p>Subwoofer Mode : Select low range signals to be reproduced by subwoofer.</p> <ul style="list-style-type: none"> • LFE : The low range signal of the channel set to "Small" speaker size is added to the LFE signal output from the subwoofer. • LFE+Main : The low range signal of all channels is added to the LFE signal output from the subwoofer. <p> This item can be set when "Speaker Configuration" – "Subwoofer" (page 53) is set to "Yes".</p> <ul style="list-style-type: none"> • Play music or a movie source and select the mode offering the strongest bass. • Select "LFE+Main" if you want the bass signals to always be produced from the subwoofer.

Setting items	Setting details
Bass Setting (Continued)	<p>LPF for LFE : Set LFE signal playback range.</p> <ul style="list-style-type: none"> • 80Hz / 90Hz / 100Hz / 110Hz / 120Hz / 150Hz / 200Hz / 250Hz <p> "LPF for LFE" can be set when "Speaker Configuration" – "Subwoofer" (page 53) is set to "Yes".</p>
Distance Set distance from listening position to speakers. Measure beforehand the distance from the listening position to each speaker.	<p>Feet / Meters : Set the unit of distance.</p> <p>Step : Set the minimum variable width of the distance.</p> <ul style="list-style-type: none"> • 1ft / 0.1ft • 0.1m / 0.01m <p>Default : Reset all distance settings to factory default.</p> <ul style="list-style-type: none"> • Yes • No <p> When you select "Default" and press ENTER, the "Return all settings to the default?" prompt is displayed. Select either "Yes" or "No", and press ENTER.</p> <p>Front L / Front R / Center / Subwoofer / Surround L / Surround R / Surround Back L* / Surround Back R* / Front Height L / Front Height R : Select the speaker.</p> <p>* When the "Speaker Configuration" – "Surround Back" setting (page 54) is set to "1spkr", "Surround Back" is displayed.</p> <ul style="list-style-type: none"> • 0.0ft – 60.0ft / 0.00m – 18.00m : Set the distance. <p> The speakers that can be selected differ depending on the "Speaker Assign" (page 53) and "Speaker Configuration" (page 53, 54) settings.</p> <ul style="list-style-type: none"> • Default settings : Front/Center/Subwoofer/Front Height : 12.0 ft (3.60 m) Surround/Surround Back : 10.0 ft (3.00 m) • Set the difference in the distance between the speakers to less than 20 feet (6.0 meters). <p>NOTE Speakers set to "None" in "Speaker Configuration" (page 53, 54) are not displayed.</p>



Setting items	Setting details
Channel Level Set the volume of the test tone to be the same when it is output from each speaker.	<p>Test Tone : Output test tone.</p> <ul style="list-style-type: none"> • Front L / Front Height L / Center / Front Height R / Front R / Surround R / Surround Back R * / Surround Back L * / Surround L / Subwoofer : Select the speaker. * When the "Speaker Configuration" – "Surround Back" setting (🔧 page 54) is set to "1spkr", "Surround Back" is displayed. • -12dB – +12dB (0dB) : Adjust the volume. <p>🔧 When ◀ is pressed while the subwoofer volume is set to "-12 dB", the "Subwoofer" setting switches to "OFF".</p> <p>NOTE</p> <ul style="list-style-type: none"> • Speakers set to "None" in the "Speaker Configuration" (🔧 page 53, 54) settings are not displayed. • When using surround speakers, be sure to adjust the volume of the different speakers. • When a headphones jack is inserted in the PHONES terminal of this unit, the "Channel Level" is not displayed. <p>Default : Reset all channel level settings to factory default.</p> <ul style="list-style-type: none"> • Yes • No
Crossover Frequency Set the maximum frequency of the bass signal output from each channel to the subwoofer. Set the Crossover Frequency to suit the bass reproduction capability of the speaker being used.	<p>40Hz / 60Hz / 80Hz / 90Hz / 100Hz / 110Hz / 120Hz / 150Hz / 200Hz / 250Hz : Set the crossover frequency.</p> <p>Advanced : Specify crossover frequency for each speaker.</p> <ul style="list-style-type: none"> • Front / Center / Surround / Surround Back / Front Height : Select the speaker. • 40Hz / 60Hz / 80Hz / 90Hz / 100Hz / 110Hz / 120Hz / 150Hz / 200Hz / 250Hz : Set the crossover frequency. <p>🔧</p> <ul style="list-style-type: none"> • Crossover frequency can be set when the "Speaker Configuration" – "Subwoofer" (🔧 page 53) setting is "Yes", or when you have a speaker that is set to "Small". • Always set the crossover frequency to "80Hz". When using small speakers, however, we recommend setting the crossover frequency to a higher frequency. • The speakers that can be set when "Advanced" is selected differ according to the "Subwoofer Mode" setting (🔧 page 54). <ul style="list-style-type: none"> • When "LFE" is selected, speakers set to "Small" at "Speaker Configuration" can be set. If the speakers are set to "Large", "Full Band" is displayed and the setting cannot be made. • If set to "LFE+Main", this setting can be made regardless of the speaker size.



HDMI Setup



Default settings are underlined.

Make settings for HDMI video/audio output.

Setting items	Setting details
HDMI Audio Out Select HDMI audio output device. This can be set when the input source on the unit is "BD/SD", "HDMI1", "HDMI2" or "HDMI3".	<p>Amp : Plays back using the speakers.</p> <p>TV : Plays back on the TV.</p> <p>🔧 When the HDMI control function is activated, priority is given to the TV audio setting (🔧 page 39 "HDMI Control Function").</p>
HDMI Control You can link operations with devices connected to HDMI and compatible with HDMI Control.	<p>Control</p> <ul style="list-style-type: none"> • ON : Use HDMI control function. • OFF : Do not use HDMI control function. <p>🔧 When a device that is not compatible with the HDMI control function is connected, set "Control" to "OFF".</p> <p>NOTE</p> <ul style="list-style-type: none"> • When "Control" is set to "ON", it consumes more standby power. If you are not using this unit for an extended period, it is recommended that you unplug the power cord from the power outlet. • "HDMI Control" does not work when the power to the equipment is off. Either turn power on or set to standby. <p>Standby Source : Sets the HDMI input source to put into standby when the power is on.</p> <ul style="list-style-type: none"> • Last : This item is set at the last-used input source. • HDMI1 / HDMI2 / HDMI3 : Put the respective input source into standby. <p>🔧 "Standby Source" can be set when "Control" is set to "ON".</p> <p>Power Off Control : Links the power standby of this unit to external equipment.</p> <ul style="list-style-type: none"> • ON • OFF <p>🔧 "Power Off Control" can be set when "Control" is set to "ON".</p>
<p>NOTE</p> <ul style="list-style-type: none"> • Please consult the operating instructions for each connected component to check the settings. • Refer to "HDMI Control Function" (🔧 page 39) for more information about the HDMI control function. 	<p>🔧</p> <ul style="list-style-type: none"> • The HDMI control function controls operations of a TV that is compatible with the HDMI control function. Make sure that the TV and HDMI are connected when you perform HDMI control. • If the "Control" settings have been changed, always reset the power to connected devices after the change.

Remote control operation buttons



Display the menu
Cancel the menu



Move the cursor
(Up/Down/Left/Right)



Confirm the setting

RETURN



Return to previous menu

Getting Started

Simple Version

Connections

Playback (Basic)

Settings

Playback (Advanced)

Multi-zone

GUI

Remote Control

Part Names

Other Information

Troubleshooting

Spec.

Index

Manual Setup



Audio Setup



Default settings are underlined.

Set the audio input and output.

Setting items	Setting details
COAX Input Assign Assign coaxial digital connector.	OFF : Do not assign coaxial digital connector. AUX1 : Sets to the digital audio input connector for AUX1. AUX2 : Sets to the digital audio input connector for AUX2. NOTE When set to "AUX1" or "AUX2", priority is given to output of COAXIAL input signals over analog or OPTICAL input signals.
Dynamic Play Mode When playing back on a 2.0/2.1-channel setup, the unused surround channels (amps) are used together with the front channels (amps) to give improved sound quality.	AUTO : Automatically ON when parallel drive possible. OFF : Parallel drive is not performed.



Option Setup



Default settings are underlined.

Make various other settings.

Setting items	Setting details
Volume Control Set the MAIN ZONE (room where the unit is located) volume setting.	Volume Limit : Make a setting for maximum volume. • OFF : Do not set a maximum volume. • 60 / 70 / 80 Power On Level : Define the volume setting that is active when the power is turned on. • Last : Use the memorized setting from the last session. • 0 - 99 : The volume is adjusted to the set level.
GUI Make GUI related settings.	Screensaver : Make screensaver settings. • ON : If is no operation is performed for approximately three minutes while the GUI menu or iPod playback screen is displayed, a screen saver is activated. When you press $\Delta \nabla \triangleleft \triangleright$, the screen saver is cancelled and the screen before that screen saver started is displayed. • OFF : Screen saver is not activated.

Setting items	Setting details
GUI (Continued)	Text : Display the details of operation when switching surround mode, input mode, etc. • ON • OFF Master Volume : Display the master volume during adjustment. • Bottom : Display at the bottom. • Top : Display at the top. • OFF : Turn display off. When the master volume display is hard to see when superimposed on movie subtitles, set to "Top".
Quick Start Mode Make Quick Mode settings.	ON : Start up time is faster but power consumption during standby is higher. OFF : Turn off Quick Mode.
Remote Preset Codes By registering the preset codes in the supplied remote control unit, you can operate a TV, satellite tuner or cable TV made by other manufacturers.	<ol style="list-style-type: none"> Select the device you want to register using $\Delta \nabla$ and press ENTER to confirm. Select the first letter of the manufacturer's name using $\Delta \nabla$ and press ENTER to confirm. Select the manufacturer's name using $\Delta \nabla$ and press ENTER to confirm. The procedures for registering remote control codes and remote control preset registration are displayed. <ul style="list-style-type: none"> Some devices you want to register may have more than one preset code. In this case, after registering the preset code, try operating the device with the remote control unit to check that it is working properly. For details on operating devices with the remote control unit after registering the preset code, see "Operating Components" (page 59).
Trigger Out Select the condition for activating Trigger Out for the input source, surround mode, etc. See "TRIGGER OUT Jacks" (page 17) for more information on trigger out.	When Setting for Zone (MAIN ZONE/ZONE2): Trigger out is activated through linkage to the power of the zone set to "ON". When Setting for Input Source: Activate trigger out when the input source set to "ON" is selected. Active for the zone set to "ON" with "When Setting for Zone". When Setting for Surround Mode: Activate trigger out when the surround mode set to "ON" is selected. Active when the "MAIN ZONE" set to "ON" with "When Setting for Zone" is selected, and when the input source set to "ON" with "When Setting for Input Source" is selected. • ON : Activate trigger on this mode. • --- : Do not activate trigger on this mode.

SETUP



Display the menu
Cancel the menu



Move the cursor
(Up/Down/Left/Right)





Confirm the setting

RETURN



Return to previous menu

Manual Setup

Setting items	Setting details
Dimmer Sensor Detects the level of brightness around the unit and automatically adjusts the brightness of the display accordingly.	ON : Automatically adjusts the brightness of the unit's display. OFF : Does not automatically adjust the brightness of the unit's display.
Dimmer Adjust the display brightness of this unit.	Bright : Normal display brightness. Dim : Reduced display brightness. Dark : Very low display brightness. OFF : Turns the display off.  "Dimmer" can be set when "Dimmer Sensor" is set to "OFF".
Setup Lock Protect settings from inadvertent change.	ON OFF  When canceling the setting, set "Setup Lock" to "OFF". NOTE When "Setup Lock" is set to "ON", the settings listed below can no longer be changed. Also, "SETUP LOCKED!" is displayed if you attempt to operate related settings. <ul style="list-style-type: none"> · GUI menu operations · RESTORER · Audio Delay · Dynamic EQ™ · Dynamic Volume™ · Audio Adjust · MultEQ®



GUI Language



Default settings are underlined.

Set the language for display on the GUI screen.

Setting details





English / Deutsch / Français / Italiano / Español / Nederlands / Svenska



Information

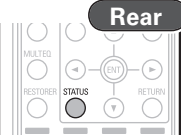

Show information about receiver settings, input signals, etc.

Items	Setting details
 Status Show information about current settings.	<input type="checkbox"/> MAIN ZONE This item shows information about settings for MAIN ZONE. The information displayed differs according to the input source. Select Source / Name / Surround Mode / Input Mode / Decode Mode / Digital <input type="checkbox"/> ZONE2 This item shows information about settings for multi-zone. Power / Select Source
 Audio Input Signal Show information about audio input signals.	Surround Mode : The currently set surround mode. Signal : The input signal type. fs : The input signal's sampling frequency. Format : The number of channels in the input signal (front, surround, LFE). Offset : The dialogue normalization correction value. Flag : This is displayed when inputting signals including a surround back channel. "MATRIX" is displayed with Dolby Digital EX and DTS-ES Matrix signals, "DISCRETE" with DTS-ES Discrete signals. <div style="border: 1px solid black; padding: 5px; margin-top: 10px;"> <p style="text-align: center;">Dialogue normalization function</p> <p>This function is automatically activated when playing Dolby Digital sources. It automatically corrects the standard signal level for individual program sources. The correction value can be checked using the STATUS.</p> <div style="text-align: right; margin-bottom: 10px;">  </div> <div style="border: 1px solid black; padding: 5px; margin: 10px auto; width: fit-content;"> <p style="text-align: center;">Dial.Norm Offset - 4dB</p> </div> <p>The figure is the correction value when the standard level is corrected.</p> </div>
 HDMI Information Show information about HDMI input/output signals and monitor.	Signal Info. Resolution / Color Space / Pixel Depth Monitor Interface / Supported resol.

Remote control operation buttons



Display the menu
Cancel the menu



Move the cursor
(Up/Down/Left/Right)



Confirm the setting

RETURN





Return to previous menu

Getting Started
Simple Version
Connections
Playback (Basic)
Settings
Playback (Advanced)
Multi-zone
GUI
Remote Control
Part Names
Other Information
Troubleshooting
Spec.
Index



Getting Started
Simple Version
Connections
Playback (Basic)
Settings
Playback (Advanced)
Multi-zone
GUI
Remote Control
Part Names
Other Information
Troubleshooting
Spec.
Index

Information	
Items	Setting details
 Auto Surround Mode Show information about auto surround mode settings.	Analog/PCM 2ch / Digital 2ch / Digital 5.1ch / Multi ch
 Preset Channel Show information about preset channels.	This item can be checked when the input source is set to FM AM . A / B / C / D / E / F / G A1 - A8 / B1 - B8 / C1 - C8 / D1 - D8 / E1 - E8 / F1 - F8 / G1 - G8

Setting Various Modes

When the input source of this unit is "BD/SD", you can switch the following modes and change the settings from the menu displayed on the screen.

1 Press **MODE**.

Displays the currently settable menu.



Play Mode	Disc
BD Audio Mode	Mix Audio Output
File filter	All

- The display content changes depending on the media being played back.

2 Select the setting item using Δ ∇ , and then press **ENTER** or \triangleright .

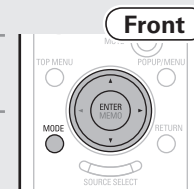
3 Use Δ ∇ to select a setting and use **ENTER** to change the setting.



Setting items	Setting details
BD Audio Mode Switch Blu-ray Disc audio playback mode.	HD Audio Output : Can view by outputting high quality signals such as Dolby TrueHD, Dolby Digital Plus, or DTS-HD as its high sound quality bitstream. Cannot listen to interactive or secondary audio. Mix Audio Output : Outputs a mix of primary audio/interactive audio/secondary audio.  In the case of Dolby TrueHD, Dolby Digital Plus and DTS-HD audio playback, set to "HD Audio Output". NOTE When "Mix Audio Output" is set and DTS-HD audio signals are played, only the DTS digital surround stream of the DTS-HD audio stream is decoded and output.
File filter Selects the file format you want to play back from among the files mixed on a disc.	All : Plays back MP3/WMA/AAC/LPCM/JPEG files. Audio : Plays back MP3/WMA/AAC/LPCM files. Picture : Plays back JPEG files. Audio & Picture : Plays back MP3/WMA/AAC/LPCM/JPEG files.  This operation is effective only when playback is stopped.
Play Mode Selects the file Play mode.	Disc : Plays back all files in the media. Folder : Plays back files in the selected folder.



Display the menu
Cancel the menu



Move the cursor
(Up/Down/Left/Right)



Confirm the setting

RETURN



Return to previous menu

Operating the Connected Devices by Remote Control Unit

Registering the supplied preset codes in the remote control unit enables you to operate devices made by other manufacturers.

Registering Preset Codes

1 Set **DEVICE SELECT** to the component to be registered.

- TV** TV
- CBL/SAT** Satellite tuner or cable TV

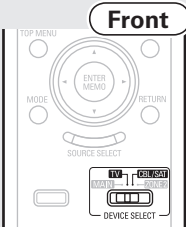

2 Press **RESOLUTION** and **ANGLE/RT** at the same time.

The signal transmission indicator starts flashing.

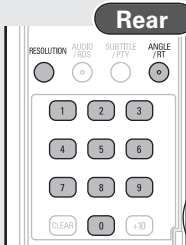

3 Press **0 - 9** and input the 3-digit number of the brand of the component to be preset. The numbers are shown in the Preset Code Table (End of this manual).

4 To store the codes of another component in the memory, repeat steps 1 to 4.



- You can also register the preset codes from the GUI menu using “Manual Setup” – “Option Setup” – “Remote Preset Codes” (page 56).
- Some manufacturers use more than one type of remote control code. Refer to the included list of preset codes to change the number and verify correct operation.
- The preset memory can be set for one component only among the following: CBL/SAT.

NOTE

Depending on the model and year of manufacture of your equipment, some buttons may not operate.

Operating Components

1 Set **DEVICE SELECT** to the component you want to operate.

- MAIN** Main unit (including operation of an iPod, Control dock for iPod, USB memory device or SD memory card connected to this unit)
- TV** TV
- CBL/SAT** Satellite tuner or cable TV

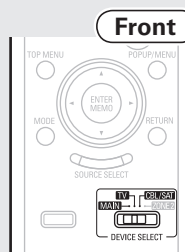

2 Operate the component.

- For details, refer to the component’s operating instructions.

NOTE

Depending on the model and year of manufacture, this function cannot be used for some models, even if they are of makes listed in the list of preset codes.

TV Operation

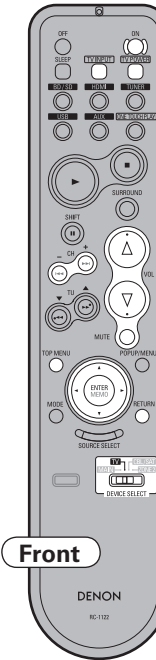

Front

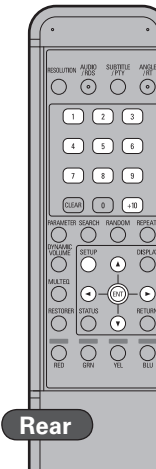

Rear

Front	
DEVICE SELECT	 DEVICE SELECT
ON	Power on/Standby
TV INPUT	Switch TV input
TV POWER	TV power on/off
CH + -	Switch channels (+, -)
VOLUME ▲▼	▲ : TV Volume (+) ▼ : TV Volume (-)
MUTE	TV mute
TOP MENU	Menu
△▽◀▶	Cursor operation
ENTER	Enter setting
RETURN	Return
Rear	
1 - 9	Channels
SETUP	Setup
Default setting (Preset code)	HITACHI (014)
Special Remarks	①

[Special Remarks]

- ① Only one device can be set in the preset memory for each mode. When a new preset code is registered, the existing code is automatically erased.

- Getting Started
- Simple Version
- Connections
- Playback (Basic)
- Settings
- Playback (Advanced)
- Multi-zone
- GUI
- Remote Control
- Part Names
- Other Information
- Troubleshooting
- Spec.
- Index



Operating Components

Set-Top Box (Satellite Tuner/Cable TV) Operation

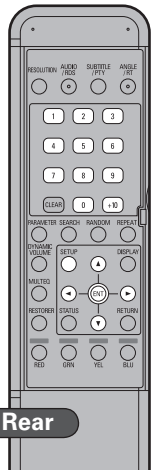
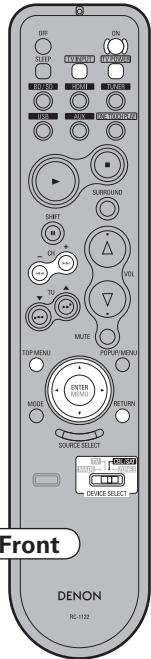

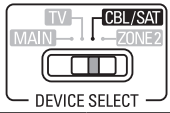
Front		
DEVICE SELECT		
ON	Power on/Standby	
TV INPUT	Switch TV input	
TV POWER	TV power on/off	
CH + -	Switch channels (+, -)	
TOP MENU	Menu	
△▽◀▶	Cursor operation	
ENTER	Enter setting	
RETURN	Return	
Rear		
0 - 9, +10	Channels	
SETUP	Setup	
Default setting (Preset code)	Satellite Tuner	
	Cable TV	ABC (009)
Special Remarks	①	

[Special Remarks]

- ① Only one device can be set in the preset memory for each mode. When a new preset code is registered, the existing code is automatically erased.

- Getting Started
- Simple Version
- Connections
- Playback (Basic)
- Settings
- Playback (Advanced)
- Multi-zone
- GUI
- Remote Control
- Part Names
- Other Information
- Troubleshooting
- Spec.
- Index

Information

Here, we list various information related to this unit.
Please refer to this information as needed.

- **Part Names and Functions**
- **Other Information**
- **Troubleshooting**
- **Specifications**
- **Index**

Part Names and Functions

Front Panel / Top Panel / Display

For buttons not explained here, see the page indicated in parentheses ().

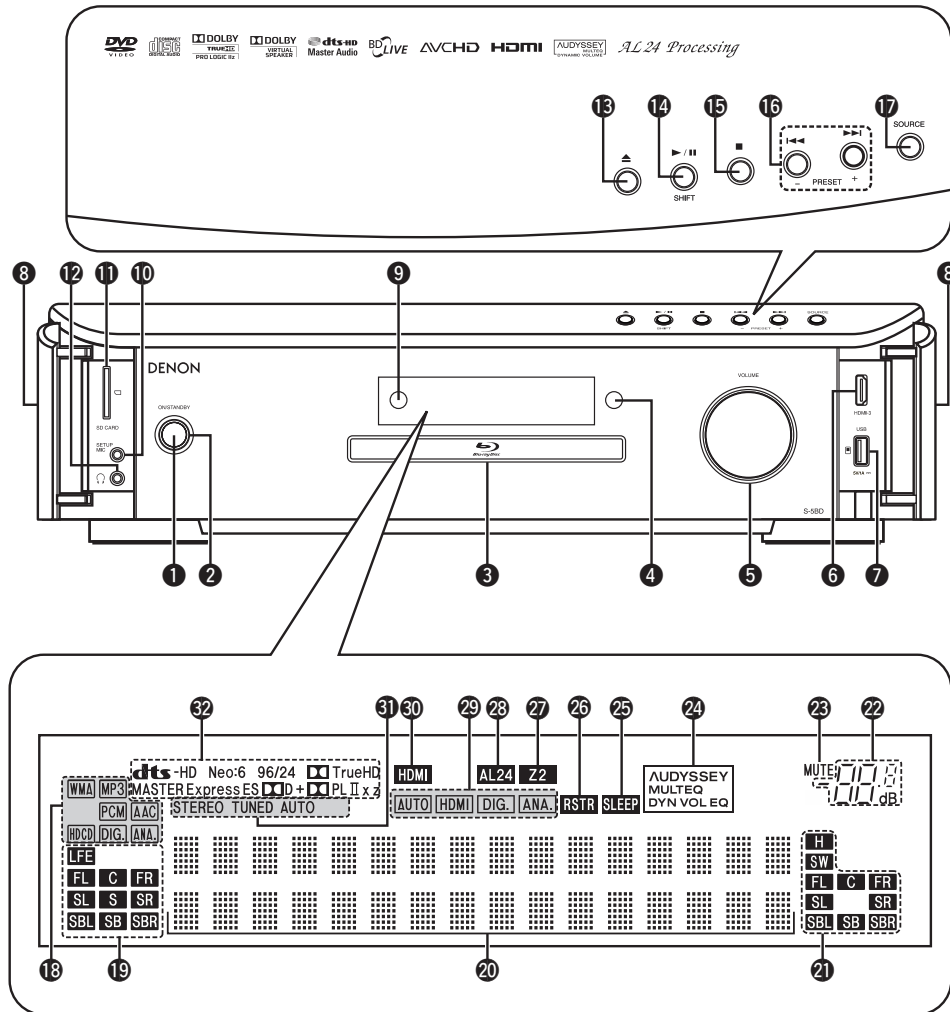

Front Panel

- 1 Power operation button (ON/STANDBY) (5)
Turns power to this unit on and off (standby).
- 2 Power indicator (5)
- 3 Disc tray (10)
- 4 Dimmer sensor (57)
- 5 VOLUME control knob (28)
- 6 HDMI-3 input connector (12)
- 7 USB (iPod) port (14)
- 8 Door (77)

NOTE

- Be careful not to catch your finger in the door.
- 9 Remote control sensor (65)
- 10 SETUP MIC jack (7, 36)

11 SD CARD slot

- Position the SD memory card so that the label side is on the right, and insert into the SD CARD slot, in the direction of the arrow.
- Insert the card straight into SD CARD slot until it clicks.
- To remove the card, push it in the direction of insertion, and then release to eject.

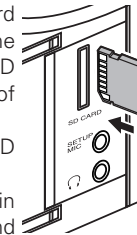

12 Headphones jack

When the headphones are plugged into this jack, audio will no longer be output from the connected speakers or from the PRE OUT connectors.

NOTE

To prevent hearing loss, do not raise the volume level excessively when using headphones.

Top Panel

- 13 Disc tray open/close button (▲) (10)
- 14 Play/Pause button (▶/||) (21, 28, 29)
SHIFT button (27)
- 15 Stop button (■) (28)
- 16 Revers-skip/Forward-skip buttons (◀◀, ▶▶) (29)
PRESET +, - buttons (27)
- 17 SOURCE button (20)



When power is in standby mode, press 13 and 14 to turn the power on.

Display

- 18 Playback format indicators
- 19 Input signal channel indicators
These light when digital signals are input.
- 20 Information display
The input source name, surround mode, setting values and other information are displayed here.
- 21 Output signal channel indicators
The channel currently being played back is displayed.
- 22 MASTER volume indicator
- 23 MUTE indicator
This lights when the mute mode is selected.

24 AUDYSSEY MULTEQ® indicators

Lighting is as follows, depending on the setting of “Dynamic EQ” (☞ page 51) and “Dynamic Volume” (☞ page 52).

AUDYSSEY MULTEQ DYN VOL	When “Dynamic EQ” and “Dynamic Volume” are “ON”.
AUDYSSEY MULTEQ DYN EQ	When “Dynamic EQ” is “ON” and “Dynamic Volume” is “OFF”.
AUDYSSEY MULTEQ	When “Dynamic EQ” and “Dynamic Volume” are “OFF”.

25 SLEEP indicator

This lights when the sleep mode is selected.

26 RESTORER indicator

This lights when the RESTORER mode is selected (☞ page 26).

27 ZONE2 indicators

This lights up when ZONE2 (separate room) power is turned on.

28 AL24 indicator

This lights when AL24 Processing (☞ page 67) is activated.

29 Input mode indicators

Set the audio input modes for the different input sources (☞ page 47).

30 HDMI indicator

This lights when playing using HDMI connections.

31 Tuner reception mode indicators

These light according to the reception conditions when the input source is set to “TUNER”.

STEREO: In the FM mode, these light when receiving analog stereo broadcasts.

TUNED: Lights when the broadcast is properly tuned in.

AUTO: These light when in the auto tuning mode.

32 Decoder indicators

These light when the respective decoders are operating.

Rear Panel

See the page indicated in parentheses ().

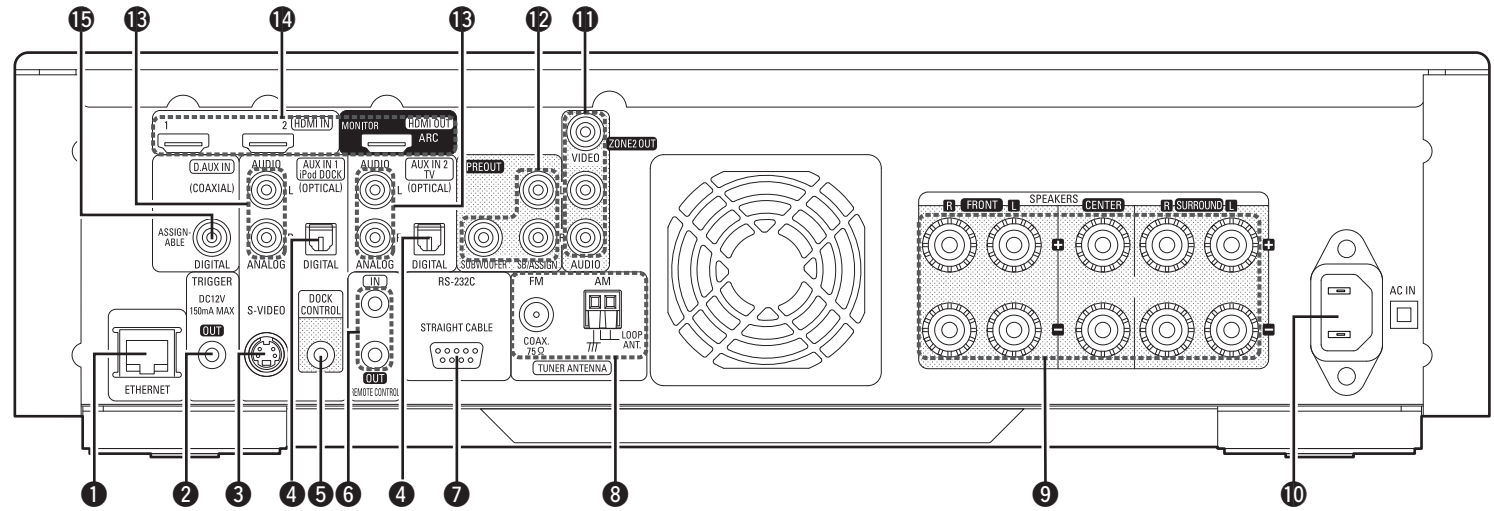

- 1** **ETHERNET connector** (16)
- 2** **TRIGGER OUT jack** (17)
- 3** **S-VIDEO connector** (14)
- 4** **OPTICAL connector** (13, 15)
- 5** **DOCK CONTROL jack** (14)
- 6** **REMOTE CONTROL jacks** (17)
- 7** **RS-232C connector** (17)
- 8** **FM/AM antenna terminals** (15)
- 9** **Speaker terminals** (4, 35)
- 10** **AC inlet (AC IN)** (5)
- 11** **ZONE2 OUT connectors** (41)
- 12** **PREOUT connectors** (35)
- 13** **Analog audio connectors** (13 – 15)
- 14** **HDMI connectors** (12)
- 15** **COAXIAL connector** (13 – 15)



When using the COAXIAL connector, set “Manual Setup” – “Audio Setup” – “COAX Input Assign” (☞ page 56) on the GUI menu to “AUX1” or “AUX2”.

NOTE

- Do not touch the inner pins of the connectors on the rear panel. Electrostatic discharge may cause permanent damage to the unit.
- Do not put your finger or foreign object in the fan opening. Doing so could cause injury or unit failure.



Remote Control Unit

For buttons not explained here, see the page indicated in parentheses ().

Front

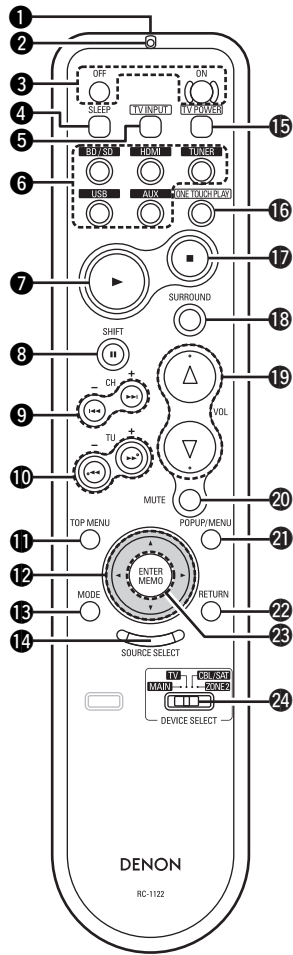

- 1 Remote control signal transmitter (65)
- 2 Signal transmission indicator (59)
- 3 Power buttons (ON, OFF) (5)
- 4 SLEEP button (40)
- 5 TV INPUT selector button (59, 60)
- 6 Input source select buttons (20)
- 7 Play (▶) button (10)
- 8 Pause (⏸) button (28)
SHIFT button (27)
- 9 SKIP (⏮, ⏭) buttons (29)
CHANNEL +, - buttons (27)
- 10 SEARCH (⏪, ⏩) buttons (29)
TUNING +, - buttons (27)
- 11 TOP MENU button (20)
- 12 Cursor buttons (▲▼◀▶) (20)
- 13 MODE button (58)
- 14 SOURCE SELECT button (20)
- 15 TV POWER button (59, 60)
- 16 ONE TOUCH PLAY button (39)
- 17 Stop (■) button (28)
- 18 SURROUND button (31)
- 19 Master volume control buttons (VOLUME) (28)
- 20 Muting button (MUTE)
Temporarily mutes the audio.
To cancel, press **MUTE** again.
- 21 POPUP/MENU button (20)
- 22 RETURN button (43)
- 23 ENTER button (43)
MEMO button (27)

- 24 **DEVICE SELECT** switch (59)
MAIN: Select this to operate this unit and the iPod.
TV: Select this to operate the TV.
CBL/SAT: Select this to operate the satellite tuner or cable TV.
ZONE2: Select this to operate ZONE2 (separate room).



For TV, satellite tuner, or cable TV operation, be sure to set the code for the remote control unit before operating the device (▶ page 59).

Rear

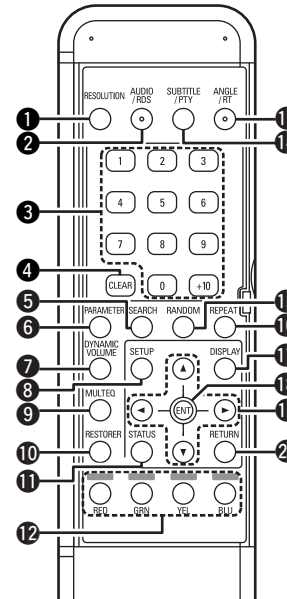

- 1 RESOLUTION button (13)
- 2 AUDIO/RDS button (30)
- 3 Number buttons (18, 59)
- 4 CLEAR button (37)
- 5 SEARCH button (37)
- 6 PARAMETER button (32)
- 7 DYNAMIC VOLUME™ button (52)
- 8 SETUP button (43)
- 9 MULTEQ® button (51)
- 10 RESTORER button (26)
- 11 STATUS button (57)
- 12 RED/GRN/YEL/BLU buttons
- 13 ANGLE/RT button (30)
- 14 SUBTITLE/PTY button (31)
- 15 RANDOM button (29)
- 16 REPEAT button (29)
- 17 DISPLAY button (18)
- 18 ENTER button (43)
- 19 Cursor buttons (▲▼◀▶) (20)
- 20 RETURN button (43)

NOTE

If buttons on the front or rear are pressed strongly, the button on the opposite side will be activated too.

Remote Control Unit

Inserting the Batteries

- ① Slide the rear lid in the direction of the arrow and remove it.

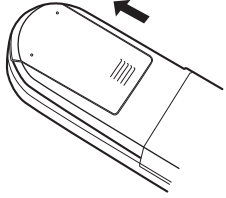

- ② Load the two batteries properly as indicated by the marks in the battery compartment.

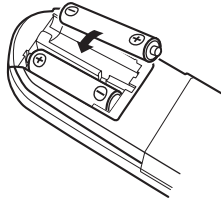

- ③ Put the rear cover back on.

NOTE

- Insert the specified batteries in the remote control unit.
- Replace the batteries with new ones if the set does not operate even when the remote control unit is operated close to the unit. (The supplied batteries are only for verifying operation.)
- When inserting the batteries, be sure to do so in the proper direction, following the ⊕ and ⊖ marks in the battery compartment.
- To prevent damage or leakage of battery fluid:
 - Do not use a new battery together with an old one.
 - Do not use two different types of batteries.
 - Do not attempt to charge dry batteries.
 - Do not short-circuit, disassemble, heat or dispose of batteries in flames.
- If the battery fluid should leak, carefully wipe the fluid off the inside of the battery compartment and insert new batteries.
- Remove the batteries from the remote control unit if it will not be in use for long periods.
- Used batteries should be disposed of in accordance with the local regulations regarding battery disposal.

Operating Range of the Remote Control Unit

Point the remote control unit at the remote sensor when operating it.

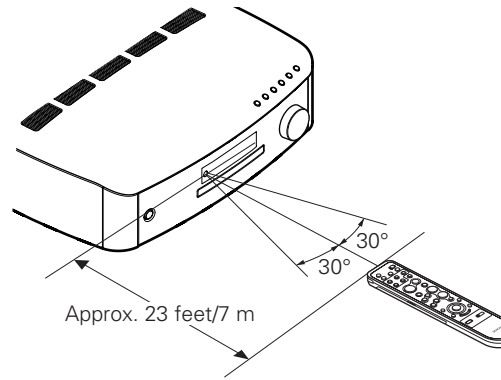
**NOTE**

The set may function improperly or the remote control unit may not operate if the remote control sensor is exposed to direct sunlight, strong artificial light from an inverter type fluorescent lamp or infrared light.

Inserting a Disc

- Set the disc with the labeled side facing up.
- Make sure the disc tray is fully open when inserting the disc.
- Place the disc horizontally in the tray, aligned with the tray guide.



If a disc that cannot be played is loaded or the disc is loaded up-sidedown, "NO DISC" is displayed on the player's display.

NOTE

- Only load one disc at a time. Loading two or more discs can damage the unit or scratch the discs.
- Do not use cracked or warped discs or discs that have been repaired with adhesive, etc.
- Do not use discs on which the sticky part of cellophane tape or labels is exposed or on which there are traces of where labels have been removed. Such discs can get caught inside the player and damage it.
- Do not use discs with special shapes, as they could damage the player.



- Do not push the disc tray in by hand when the power is turned off. Doing so could damage the set.

Other Information

- ❑ **About Discs and Files** (👉 page 66)
- ❑ **About Handling of Media** (👉 page 66)
- ❑ **Cleaning Discs** (👉 page 66)
- ❑ **About Copyright** (👉 page 67)
- ❑ **AL24 Processing** (👉 page 67)
- ❑ **Trademark Information** (👉 page 67)
- ❑ **Surround** (👉 page 68)
- ❑ **Language Code List** (👉 page 70)
- ❑ **Country Code List** (👉 page 71)
- ❑ **Explanation of Terms** (👉 page 72)

About Discs and Files

❑ **BD-Video, DVD-Video**

BD-Video/DVD-Video discs are divided into several large sections (titles) and small sections (chapter). These sections are all allotted numbers, called the title numbers and chapter numbers.

[Example]

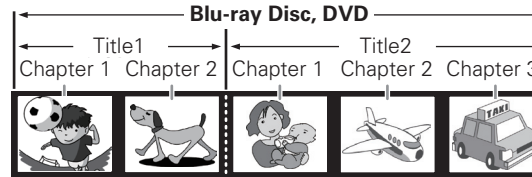

❑ **CD**

CDs are divided into several sections (tracks). These sections are all allotted numbers, called the track numbers.



❑ **File**

MP3/WMA/AAC/LPCM/JPEG files recorded on DVD-R/-RW/+R/+RW, CD-R/-RW and SD memory card are divided into large segments (folders) and small segments (files). Files are stored in folders, and folders can be placed for storage in a hierarchy. This unit can recognize up to 8 hierarchies of folder.

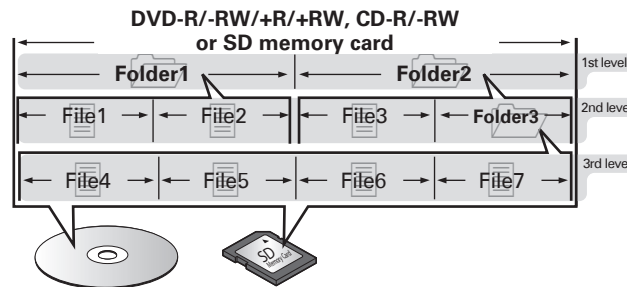

When writing MP3/WMA/AAC/JPEG files on a CD-R/-RW disc, set the writing software's format to "ISO9660". The files may not play properly if they are recorded in other formats. For details, refer to the instructions of your writing software.

About Handling of Media

- Do not get fingerprints, oil or dirt on discs.
- Take special care not to scratch discs when removing them from their cases.
- Do not bend or heat discs.
- Do not enlarge the hole at the center.
- Do not write on the labeled (printed) surface with ball-point pens, pencils, etc., or stick new labels on discs.
- Water droplets may form on discs if they are moved suddenly from a cold place (outdoors for example) to a warm place, but do not try to dry them off using a hairdryer, etc.
- Do not eject an SD memory card or turn off this unit's power while the card content is in playback. This may result in malfunction or loss of the card's data.
- Do not attempt to open or modify SD memory cards.
- SD memory cards and files can be damaged by static electricity. Do not touch the metal contacts of an SD memory card with your fingers.
- Do not use warped SD memory cards.
- After use, be sure to remove any disc or SD memory card, and store it in its proper card case, to avoid dust, scratches and deformation.
- Do not store discs in the following places:
 1. Places exposed to direct sunlight for long periods of time
 2. Dusty or humid places
 3. Places exposed to heat from heating appliances, etc.

Cleaning Discs

- If there are fingerprints or dirt on discs, wipe them off before using the disc.
- Use a commercially available disc cleaning set or a soft cloth to clean discs.



Gently wipe the disc from the inside towards the outside.

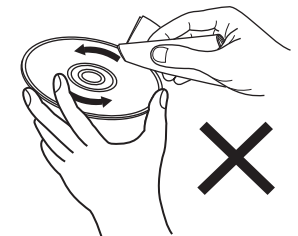

Do not wipe with a circular motion.

NOTE

If buttons on the front or rear are pressed strongly, the button on the opposite side will be activated too.

About Copyright

- Unauthorised copying, broadcasting, public performance and lending of discs are prohibited.
- This product incorporates copyright protection technology that is protected by U.S. patents and other intellectual property rights. Use of this copyright protection technology must be authorised by Macrovision, and is intended for home and other limited viewing uses only unless otherwise authorised by Macrovision. Reverse engineering or disassembly is prohibited.
- Portions of this product are protected under copyright law and provided under license by ARIS/SOLANA/4C.

AL24 Processing

AL24 Processing has inherited the technology of the original ALPHA Processing that was used in DENON's highly-successful reference-class audio components.

AL24 Processing further reduces quantization distortion and represents the ultimate analog waveform reproduction technology designed to support the higher numbers of bits and higher sampling.

AL24 Processing senses the nature of the digital data being input and interpolates the data so that it faithfully replicates the original analog waveform. AL24 Processing operates when CD, MP3 or WMA data is inputted.

Trademark Information

This product uses the following technologies:

	DVD is a trademark of the DVD Format / Logo licensing Corporation.
	Manufactured under license from Dolby Laboratories. Dolby, Pro Logic and the double-D symbol (DD) are trademarks of Dolby Laboratories.
	Manufactured under license under U.S. Patent #'s: 5,451,942; 5,956,674; 5,974,380; 5,978,762; 6,226,616; 6,487,535; 7,212,872; 7,333,929; 7,392,195; 7,272,567 & other U.S. and worldwide patents issued & pending. DTS is a registered trademark and the DTS logos, Symbol, DTS-HD and DTS-HD Master Audio are trademarks of DTS, Inc.© 1996-2008 DTS, Inc. All Rights Reserved.
	"BD-LIVE" logo is trademark of Blu-ray Disc Association.
	"AVCHD" and "AVCHD" logo is the trademark of Panasonic Corporation and Sony Corporation.
	HDMI, the HDMI logo and High-Definition Multimedia Interface are trademarks or registered trademarks of HDMI Licensing LLC.
	Manufactured under license from Audyssey Laboratories™. U.S. and foreign patents pending. Audyssey MultEQ® is a registered trademark of Audyssey Laboratories. Audyssey Dynamic EQ™ is a trademark of Audyssey Laboratories. Audyssey Dynamic Volume™ is a trademark of Audyssey Laboratories.
	"Blu-ray Disc" and  are trademarks.
	Java and all other trademarks and logos are trademarks or registered trademarks of Sun Microsystems, Inc. in the United States and/or other countries.

	Windows Media and the Windows logo are trademarks or registered trademarks of Microsoft Corporation in the United States and/or other countries.
BONUS VIEW™	"BONUSVIEW" is the trademark of Blu-ray Disc Association.
	SDHC logo is a trademark.

- Getting Started
- Simple Version
- Connections
- Playback (Basic)
- Settings
- Playback (Advanced)
- Multi-zone
- GUI
- Remote Control
- Part Names
- Other Information
- Troubleshooting
- Spec.
- Index



Surround

This unit is equipped with a digital signal processing circuit that lets you play program sources in the surround mode to achieve the same sense of presence as in a movie theater.

Surround Modes and Audio Adjust

Surround Mode (☞ page 31)	Signals and adjustability in the different modes					
	Channel output					
	Front L/R	Center	Surround L/R	Surround Back L/R	Subwoofer	Front Height L/R
STEREO	<input type="radio"/>				<input type="radio"/>	
DOLBY PRO LOGIC IIz	<input type="radio"/>	<input checked="" type="radio"/>	<input checked="" type="radio"/>		<input checked="" type="radio"/>	<input checked="" type="radio"/>
DOLBY PRO LOGIC IIx	<input type="radio"/>	<input checked="" type="radio"/>	<input checked="" type="radio"/>	<input checked="" type="radio"/>	<input checked="" type="radio"/>	
DOLBY PRO LOGIC II	<input type="radio"/>	<input checked="" type="radio"/>	<input checked="" type="radio"/>		<input checked="" type="radio"/>	
DTS NEO:6	<input type="radio"/>	<input checked="" type="radio"/>	<input checked="" type="radio"/>	<input checked="" type="radio"/>	<input checked="" type="radio"/>	
DOLBY DIGITAL	<input type="radio"/>	<input checked="" type="radio"/>	<input checked="" type="radio"/>	<input checked="" type="radio"/>	<input checked="" type="radio"/>	<input checked="" type="radio"/> (NOTE1)
DOLBY DIGITAL Plus	<input type="radio"/>	<input checked="" type="radio"/>	<input checked="" type="radio"/>	<input checked="" type="radio"/>	<input checked="" type="radio"/>	<input checked="" type="radio"/> (NOTE1)
DOLBY TrueHD	<input type="radio"/>	<input checked="" type="radio"/>	<input checked="" type="radio"/>	<input checked="" type="radio"/>	<input checked="" type="radio"/>	<input checked="" type="radio"/> (NOTE1)
DTS SURROUND	<input type="radio"/>	<input checked="" type="radio"/>	<input checked="" type="radio"/>	<input checked="" type="radio"/>	<input checked="" type="radio"/>	<input checked="" type="radio"/> (NOTE1)
DTS 96/24	<input type="radio"/>	<input checked="" type="radio"/>	<input checked="" type="radio"/>	<input checked="" type="radio"/>	<input checked="" type="radio"/>	<input checked="" type="radio"/> (NOTE1)
DTS-HD	<input type="radio"/>	<input checked="" type="radio"/>	<input checked="" type="radio"/>	<input checked="" type="radio"/>	<input checked="" type="radio"/>	<input checked="" type="radio"/> (NOTE1)
DTS EXPRESS	<input type="radio"/>	<input checked="" type="radio"/>	<input checked="" type="radio"/>	<input checked="" type="radio"/>	<input checked="" type="radio"/>	<input checked="" type="radio"/> (NOTE1)
MULTI CH STEREO	<input type="radio"/>	<input checked="" type="radio"/>	<input checked="" type="radio"/>	<input checked="" type="radio"/>	<input checked="" type="radio"/>	<input checked="" type="radio"/>
ROCK ARENA	<input type="radio"/>	<input checked="" type="radio"/>	<input checked="" type="radio"/>	<input checked="" type="radio"/>	<input checked="" type="radio"/>	<input checked="" type="radio"/>
JAZZ CLUB	<input type="radio"/>	<input checked="" type="radio"/>	<input checked="" type="radio"/>	<input checked="" type="radio"/>	<input checked="" type="radio"/>	<input checked="" type="radio"/>
DOLBY VIRTUAL SPEAKER	<input type="radio"/>				<input checked="" type="radio"/>	

- Signal/Adjustable
- Turned on or off by speaker configuration setting

NOTE1 This parameter is available when the "Front Height" is set to "ON" (☞ page 49).

NOTE2 This parameter is available when the "Mode" is set to "Cinema" (☞ page 32).

NOTE3 This parameter is available when the "Mode" is set to "Cinema" or "ProLogic" (☞ page 32).

NOTE4 BASS +6 dB, TREBLE +4 dB

NOTE :

- * 1 When playing Dolby TrueHD signal.
- * 2 When playing Dolby Digital and DTS signals.

Surround Mode (☞ page 31)	Signals and adjustability in the different modes																	
	Audio Adjust (default values are shown in parentheses) (☞ page 48)																	
	Mode	Cinema EQ.	DRC * 1	D. COMP * 2	LFE * 2	NEO:6 MUSIC mode only			PRO LOGIC II/IIx MUSIC mode only			Front Height	AFDM * 2	Surround Back	Tone Control	MultEQ	Dynamic EQ	Dynamic Volume
						Center Image	Panorama	Dimension	Center Width	Panorama	Dimension							
STEREO			<input type="radio"/> (Auto)	<input type="radio"/> (OFF)	<input type="radio"/> (0 dB)									<input type="radio"/> (OFF)	<input type="radio"/> (OFF)	<input type="radio"/>	<input type="radio"/>	
DOLBY PRO LOGIC IIz	<input type="radio"/> (Height)	<input type="radio"/> (OFF)	<input type="radio"/> (Auto)	<input type="radio"/> (OFF)	<input type="radio"/> (0 dB)						<input type="radio"/>			<input type="radio"/> (OFF)	<input type="radio"/> (OFF)	<input type="radio"/>	<input type="radio"/>	
DOLBY PRO LOGIC IIx	<input type="radio"/> (Cinema)	<input type="radio"/> (NOTE2)	<input type="radio"/> (Auto)	<input type="radio"/> (OFF)					<input type="radio"/> (OFF)	<input type="radio"/> (3)	<input type="radio"/> (3)		<input type="radio"/>	<input type="radio"/> (OFF)	<input type="radio"/> (OFF)	<input type="radio"/>	<input type="radio"/>	
DOLBY PRO LOGIC II	<input type="radio"/> (Cinema)	<input type="radio"/> (NOTE3)	<input type="radio"/> (Auto)	<input type="radio"/> (OFF)					<input type="radio"/> (OFF)	<input type="radio"/> (3)	<input type="radio"/> (3)	<input type="radio"/>	<input type="radio"/>	<input type="radio"/> (OFF)	<input type="radio"/> (OFF)	<input type="radio"/>	<input type="radio"/>	
DTS NEO:6	<input type="radio"/> (Cinema)	<input type="radio"/> (NOTE2)		<input type="radio"/> (OFF)		<input type="radio"/> (0.3)						<input type="radio"/>	<input type="radio"/>	<input type="radio"/> (OFF)	<input type="radio"/> (OFF)	<input type="radio"/>	<input type="radio"/>	
DOLBY DIGITAL		<input type="radio"/> (OFF)		<input type="radio"/> (OFF)	<input type="radio"/> (0 dB)						<input type="radio"/>	<input type="radio"/> (ON)	<input type="radio"/>	<input type="radio"/> (OFF)	<input type="radio"/> (OFF)	<input type="radio"/>	<input type="radio"/>	
DOLBY DIGITAL Plus		<input type="radio"/> (OFF)		<input type="radio"/> (OFF)	<input type="radio"/> (0 dB)						<input type="radio"/>	<input type="radio"/> (ON)	<input type="radio"/>	<input type="radio"/> (OFF)	<input type="radio"/> (OFF)	<input type="radio"/>	<input type="radio"/>	
DOLBY TrueHD		<input type="radio"/> (OFF)	<input type="radio"/> (Auto)		<input type="radio"/> (0 dB)						<input type="radio"/>	<input type="radio"/> (ON)	<input type="radio"/>	<input type="radio"/> (OFF)	<input type="radio"/> (OFF)	<input type="radio"/>	<input type="radio"/>	
DTS SURROUND		<input type="radio"/> (OFF)		<input type="radio"/> (OFF)	<input type="radio"/> (0 dB)						<input type="radio"/>	<input type="radio"/> (ON)	<input type="radio"/>	<input type="radio"/> (OFF)	<input type="radio"/> (OFF)	<input type="radio"/>	<input type="radio"/>	
DTS 96/24		<input type="radio"/> (OFF)		<input type="radio"/> (OFF)	<input type="radio"/> (0 dB)						<input type="radio"/>	<input type="radio"/> (ON)	<input type="radio"/>	<input type="radio"/> (OFF)	<input type="radio"/> (OFF)	<input type="radio"/>	<input type="radio"/>	
DTS-HD		<input type="radio"/> (OFF)		<input type="radio"/> (OFF)	<input type="radio"/> (0 dB)						<input type="radio"/>	<input type="radio"/> (ON)	<input type="radio"/>	<input type="radio"/> (OFF)	<input type="radio"/> (OFF)	<input type="radio"/>	<input type="radio"/>	
DTS EXPRESS		<input type="radio"/> (OFF)		<input type="radio"/> (OFF)	<input type="radio"/> (0 dB)					<input type="radio"/>	<input type="radio"/> (ON)	<input type="radio"/>	<input type="radio"/>	<input type="radio"/> (OFF)	<input type="radio"/> (OFF)	<input type="radio"/>	<input type="radio"/>	
MULTI CH STEREO				<input type="radio"/> (OFF)	<input type="radio"/> (0 dB)							<input type="radio"/>	<input type="radio"/>	<input type="radio"/> (OFF)	<input type="radio"/> (OFF)	<input type="radio"/>	<input type="radio"/>	
ROCK ARENA				<input type="radio"/> (OFF)	<input type="radio"/> (0 dB)							<input type="radio"/>	<input type="radio"/> (NOTE4)	<input type="radio"/> (OFF)	<input type="radio"/> (OFF)	<input type="radio"/>	<input type="radio"/>	
JAZZ CLUB				<input type="radio"/> (OFF)	<input type="radio"/> (0 dB)							<input type="radio"/>	<input type="radio"/>	<input type="radio"/> (OFF)	<input type="radio"/> (OFF)	<input type="radio"/>	<input type="radio"/>	
DOLBY VIRTUAL SPEAKER			<input type="radio"/> (Auto)	<input type="radio"/> (OFF)	<input type="radio"/> (0 dB)									<input type="radio"/> (OFF)	<input type="radio"/> (OFF)	<input type="radio"/>	<input type="radio"/>	



Types of Input Signals, and Corresponding Surround Modes

Operation Buttons		Input Signal Types and Formats																		
Surround Mode (page 31)	Note	ANALOG	LINEAR PCM/WAV	WMA (Windows Media Audio)/MP3/MPEG-4 AAC/FLAC	DTS-HD		DTS				DOLBY		DOLBY DIGITAL					MULTI CH PCM		
					DTS-HD Master Audio	DTS-HD High Resolution Audio	DTS EXPRESS	DTS ES DSCRT (With Flag)	DTS ES MTRX (With Flag)	DTS (5.1ch)	DTS 96/24	DOLBY TrueHD	DOLBY DIGITAL Plus	DOLBY DIGITAL EX (With Flag)	DOLBY DIGITAL EX (With no Flag)	DOLBY DIGITAL (5.1/5/4ch)	DOLBY DIGITAL (4/3ch)	DOLBY DIGITAL (2ch)	PCM (multi ch)	PCM (2ch)
SURROUND button																				
DTS SURROUND																				
DTS-HD MSTR					●															
DTS-HD HI RES						●														
DTS ES DSCRT6.1	* 1							●	◎											
DTS ES MTRX6.1	* 1								●	◎										
DTS SURROUND									○	○	●									
DTS 96/24											●									
DTS (-HD) + PLIIx CINEMA	* 2				○	○	○	○	○	○	○	○								
DTS (-HD) + PLIIx MUSIC	* 1				○	○	○	○	○	○	○	○								
DTS (-HD) + PLIIz HEIGHT	* 3				○	○	○	○	○	○	○	○								
DTS EXPRESS							●													
DTS (-HD) + NEO:6	* 1				○	○	○		○	○	○									
DTS NEO:6 CINEMA		○	○	○															○	○
DTS NEO:6 MUSIC		○	○	○															○	○
DOLBY SURROUND																				
DOLBY TrueHD												●								
DOLBY DIGITAL+													●							
DOLBY DIGITAL EX	* 1												○	○	○	○				
DOLBY (D+) (HD) +EX	* 1											○	○							
DOLBY DIGITAL													○	●	●	●				
DOLBY (D) (D+) (HD) +PLIIx CINEMA	* 2											○	○	●	◎	○	○	○		
DOLBY (D) (D+) (HD) +PLIIx MUSIC	* 1											○	○	○	○	○	○			
DOLBY (D) (D+) (HD) +PLIIz HEIGHT	* 3											○	○	○	○	○	○			
DOLBY PRO LOGIC IIz HEIGHT	* 3	○	○	○															○	○
DOLBY PRO LOGIC IIx CINEMA	* 1	○	○	○															○	○
DOLBY PRO LOGIC IIx MUSIC	* 1	○	○	○															○	○
DOLBY PRO LOGIC IIx GAME	* 1	○	○	○															○	○
DOLBY PRO LOGIC II CINEMA		○	○	○															○	○
DOLBY PRO LOGIC II MUSIC		○	○	○															○	○
DOLBY PRO LOGIC II GAME		○	○	○															○	○
DOLBY PRO LOGIC		○	○	○															○	○
DOLBY VIRTUAL SPEAKER REFERENCE	* 4	○	○	○	○	○	○	○	○	○	○	○	○	○	○	○	○	○	○	○
DOLBY VIRTUAL SPEAKER WIDE	* 4	○	○	○	○	○	○	○	○	○	○	○	○	○	○	○	○	○	○	○
MULTI CH STEREO		○	○	○															○	○
ROCK ARENA		○	○	○															○	○
JAZZ CLUB		○	○	○															○	○
STEREO		●	●	●	○	○	○	○	○	○	○	○	○	○	○	○	○	○	○	○

NOTE

- * 1 This mode is not available when the surround back speaker setup is set to "None".
- * 2 This mode is not available when the surround back speaker setup is set to "1spkr" or "None".
- * 3 This mode is not available when the front height speaker setup is set to "None".
- * 4 This mode is available when the speaker setting is "2ch/2.1ch".

- Mode selectable in initial status
- ◎ Mode fixed when "AFDM" is "ON"
- Selectable mode

Getting Started

Simple Version

Connections

Playback (Basic)

Settings

Playback (Advanced)

Multi-zone

GUI

Remote Control

Part Names

Other Information

Troubleshooting

Spec.

Index



Language Code List

Language	Code
A Abkhazian	4748
Afar	4747
Afrikaans	4752
Albanian	6563
Amharic	4759
Arabic	4764
Armenian	5471
Assamese	4765
Aymara	4771
Azerbaijani	4772
B Bashkir	4847
Basque	5167
Bengali; Bangla	4860
Bhutani	5072
Bihari	4854
Bislama	4855
Breton	4864
Bulgarian	4853
Burmese	5971
Byelorussian	4851
C Cambodian	5759
Catalan	4947
Chinese	7254
Corsican	4961
Croatian	5464
Czech	4965
D Danish	5047
Dutch	6058
E English	5160
Esperanto	5161
Estonian	5166
F Faroese	5261
Fiji	5256
Finnish	5255
French	5264
Frisian	5271
G Galician	5358
Georgian	5747
German	5051
Greek	5158
Greenlandic	5758
Guarani	5360
Gujarati	5367
H Hausa	5447
Hebrew	5569
Hindi	5455
Hungarian	5467

Language	Code
I Icelandic	5565
Indonesian	5560
Interlingua	5547
Interlingue	5551
Inupiak	5557
Irish	5347
Italian	5566
J Japanese	5647
Javanese	5669
K Kannada	5760
Kashmiri	5765
Kazakh	5757
Kinyarwanda	6469
Kirghiz	5771
Kirundi	6460
Korean	5761
Kurdish	5767
L Laothian	5861
Latin	5847
Latvian; Lettish	5868
Lingala	5860
Lithuanian	5866
M Macedonian	5957
Malagasy	5953
Malay	5965
Malayalam	5958
Maltese	5966
Maori	5955
Marathi	5964
Moldavian	5961
Mongolian	5960
N Nauru	6047
Nepali	6051
Norwegian	6061
O Occitan	6149
Oriya	6164
Oromo (Afan)	6159
P Panjabi	6247
Pashto; Pushto	6265
Persian	5247
Polish	6258
Portuguese	6266
Q Quechua	6367
R Rhaeto-Romance	6459
Romanian	6461
Russian	6467

Language	Code
S Samoan	6559
Sangho	6553
Sanskrit	6547
Scots Gaelic	5350
Serbian	6564
Serbo-Croatian	6554
Sesotho	6566
Setswana	6660
Shona	6560
Sindhi	6550
Singhalese	6555
Siswat	6565
Slovak	6557
Slovenian	6558
Somali	6561
Spanish	5165
Sundanese	6567
Swahili	6569
Swedish	6568
T Tagalog	6658
Tajik	6653
Tamil	6647
Tatar	6666
Telugu	6651
Thai	6654
Tibetan	4861
Tigrinya	6655
Tonga	6661
Tsonga	6665
Turkish	6664
Turkmen	6657
Twi	6669
U Ukrainian	6757
Urdu	6764
Uzbek	6772
V Vietnamese	6855
Volapuk	6861
W Welsh	4971
Wolof	6961
X Xhosa	7054
Y Yiddish	5655
Yoruba	7161
Z Zulu	7267

Country Code List

Country	Code	Country	Code	Country	Code	Country	Code	Country	Code
A AFGHANISTAN	AF	CROATIA	HR	J JAMAICA	JM	NIGERIA	NG	SYRIAN ARAB REPUBLIC	SY
ÅLAND ISLANDS	AX	CUBA	CU	JERSEY	JE	NIUE	NU	T TAJIKISTAN	TJ
ALBANIA	AL	CYPRUS	CY	JORDAN	JO	NORFOLK ISLAND	NF	TANZANIA, UNITED	TZ
ALGERIA	DZ	CZECH REPUBLIC	CZ	K KAZAKHSTAN	KZ	NORTHERN MARIANA	MP	REPUBLIC OF	
AMERICAN SAMOA	AS	D DJIBOUTI	DJ	KENYA	KE	ISLANDS		TIMOR-LESTE	TL
ANDORRA	AD	DOMINICA	DM	KIRIBATI	KI	O OMAN	OM	TOGO	TG
ANGOLA	AO	DOMINICAN REPUBLIC	DO	KOREA, DEMOCRATIC	KP	P PALAU	PW	TOKELAU	TK
ANGUILLA	AI	E ECUADOR	EC	PEOPLE'S REPUBLIC OF		PALESTINIAN TERRITORY,	PS	TONGA	TO
ANTARCTICA	AQ	EGYPT	EG	KUWAIT	KW	OCCUPIED		TRINIDAD AND TOBAGO	TT
ANTIGUA AND BARBUDA	AG	EL SALVADOR	SV	KYRGYZSTAN	KG	PANAMA	PA	TUNISIA	TN
ARMENIA	AM	EQUATORIAL GUINEA	GQ	LAO PEOPLE'S	LA	PAPUA NEW GUINEA	PG	TURKEY	TR
ARUBA	AW	ERITREA	ER	DEMOCRATIC REPUBLIC		PARAGUAY	PY	TURKMENISTAN	TM
AZERBAIJAN	AZ	ESTONIA	EE	LATVIA	LV	PERU	PE	TURKS AND CAICOS	TC
B BAHAMAS	BS	ETHIOPIA	ET	LEBANON	LB	PITCAIRN	PN	ISLANDS	
BAHRAIN	BH	F FALKLAND ISLANDS	FK	LESOTHO	LS	PUERTO RICO	PR	TUVALU	TV
BANGLADESH	BD	(MALVINAS)		LIBERIA	LR	Q QATAR	QA	U UGANDA	UG
BARBADOS	BB	FAROE ISLANDS	FO	LIBYAN ARAB JAMAHIRIYA	LY	R RÉUNION	RE	UKRAINE	UA
BELARUS	BY	FIJI	FJ	LIECHTENSTEIN	LI	ROMANIA	RO	UNITED ARAB EMIRATES	AE
BELIZE	BZ	FRENCH GUIANA	GF	LITHUANIA	LT	RWANDA	RW	UNITED STATES MINOR	UM
BENIN	BJ	FRENCH POLYNESIA	PF	M MACAO	MO	S SAINT BARTHÉLEMY	BL	OUTLYING ISLANDS	
BERMUDA	BM	FRENCH SOUTHERN	TF	MACEDONIA, THE FORMER	MK	SAINT HELENA	SH	URUGUAY	UY
BHUTAN	BT	TERRITORIES		YUGOSLAV REPUBLIC OF		SAINT KITTS AND NEVIS	KN	UZBEKISTAN	UZ
BOLIVIA	BO	G GABON	GA	MADAGASCAR	MG	SAINT LUCIA	LC	V VANUATU	VU
BOSNIA AND		GAMBIA	GM	MALAWI	MW	SAINT MARTIN	MF	VATICAN CITY STATE	VA
HERZEGOVINA	BA	GEORGIA	GE	MALDIVES	MV	SAINT PIERRE AND	PM	VENEZUELA	VE
BOTSWANA	BW	GHANA	GH	MALI	ML	MIQUELON		VIET NAM	VN
BOUVET ISLAND	BV	GIBRALTAR	GI	MALTA	MT	SAINT VINCENT AND THE	VC	VIRGIN ISLANDS, BRITISH	VG
BRITISH INDIAN OCEAN		GREENLAND	GL	MARSHALL ISLANDS	MH	GRENADINES		VIRGIN ISLANDS, U.S.	VI
TERRITORY	IO	GRENADA	GD	MARTINIQUE	MQ	SAMOA	WS	W WALLIS AND FUTUNA	WF
BRUNEI DARUSSALAM	BN	GUADELOUPE	GP	MAURITANIA	MR	SAN MARINO	SM	WESTERN SAHARA	EH
BULGARIA	BG	GUAM	GU	MAURITIUS	MU	SAO TOME AND PRINCIPE	ST	Y YEMEN	YE
BURKINA FASO	BF	GUATEMALA	GT	MAYOTTE	YT	SAUDI ARABIA	SA	Z ZAMBIA	ZM
BURUNDI	BI	GUERNSEY	GG	MICRONESIA, FEDERATED	FM	SENEGAL	SN	ZIMBABWE	ZW
C CAMBODIA	KH	GUINEA	GN	STATES OF		SERBIA	RS		
CAMEROON	CM	GUINEA-BISSAU	GW	MOLDOVA	MD	SEYCHELLES	SC		
CAPE VERDE	CV	GUYANA	GY	MONACO	MC	SIERRA LEONE	SL		
CAYMAN ISLANDS	KY	H HAITI	HT	MONGOLIA	MN	SLOVAKIA	SK		
CENTRAL AFRICAN		HEARD ISLAND AND	HM	MONTENEGRO	ME	SLOVENIA	SI		
REPUBLIC	CF	MCDONALD ISLANDS		MONTSERRAT	MS	SOLOMON ISLANDS	SB		
CHAD	TD	HOLY SEE (VATICAN CITY	VA	MOROCCO	MA	SOMALIA	SO		
CHRISTMAS ISLAND	CX	STATE)		MOZAMBIQUE	MZ	SOUTH AFRICA	ZA		
COCOS (KEELING) ISLANDS	CC	HONDURAS	HN	MYANMAR	MM	SOUTH GEORGIA AND			
COMOROS	KM	HUNGARY	HU	NAMIBIA	NA	THE SOUTH SANDWICH	GS		
CONGO	CG	I ICELAND	IS	NAURU	NR	ISLANDS			
CONGO, THE DEMOCRATIC		IRAN, ISLAMIC REPUBLIC	IR	NEPAL	NP	SRI LANKA	LK		
REPUBLIC OF THE	CD	OF		NETHERLANDS ANTILLES	AN	SUDAN	SD		
COOK ISLANDS	CK	IRAQ	IQ	NEW CALEDONIA	NC	SURINAME	SR		
COSTA RICA	CR	ISLE OF MAN	IM	NICARAGUA	NI	SVALBARD AND JAN	SJ		
CÔTE D'IVOIRE	CI	ISRAEL	IL	NIGER	NE	MAYEN			
						SWAZILAND	SZ		

Explanation of Terms

Numerics

4:3 LB (letterbox)

When a wide (16:9) disc is played back by connecting a 4:3 TV and this unit, this function plays back the image with black area at the top and bottom.

4:3 PS (pan scan)

When a wide (16:9) disc is played back by connecting a 4:3 TV and this unit, this function cuts left and right of the played back image to the 4:3 size according to the disc's control information.

A

AAC (Advanced Audio Coding)

This is an internationally standardized audio data compression scheme. It has a compression ratio 1.4 times higher than the "MP3 audio compression scheme adopted for "MPEG-1.

Aspect ratio

This is the length and width ratio of the TV screen. The conventional TV's screen ratio is 4:3 and the wide screen TV's screen ratio is 16:9.

Audio commentary

This is an audio program included as a bonus feature in a DVD-Video or BD-Video. It uses a multi-audio function to provide an audio explanation or commentary by members of the crew or director, etc. to accompany the video.

Audyssey Dynamic EQ™

Audyssey Dynamic EQ solves the problem of deteriorating sound quality as volume is decreased by taking into account human perception and room acoustics. Audyssey Dynamic EQ works in tandem with Audyssey MultEQ® to provide well-balanced sound for every listener at any volume level.

Audyssey Dynamic Volume™

Audyssey Dynamic Volume solves the problem of large variations in volume level between television programs, commercials, and between the soft and loud passages of movies. Audyssey Dynamic EQ is integrated into Dynamic Volume so that as the playback volume is adjusted automatically, the perceived bass response, tonal balance, surround impression, and dialog clarity remain the same.

Audyssey MultEQ®

Audyssey MultEQ is a room equalization solution that calibrates any audio system so that it can achieve optimum performance for every listener in a large listening area. Based on several room measurements, MultEQ calculates an equalization solution that corrects for both time and frequency response problems in the listening area and also performs a fully automated surround system setup.

AVCHD (Advanced Video Codec High Definition)

This is a high-definition digital camera (HD) standard using high-efficiency encoding technology for recording high-definition Hi-Vision signals to various media.

B

BD-J (Blu-ray Disc Java)

With BD-Videos, there are fun software with more interactive functions (games) using Java applications.

BD-LIVE

This unit can be connected to the Internet to enjoy a number of features, including additional contents such as special videos or subtitles, network games, etc.

Bit rate

This expresses the read amount per 1 second of video/audio data recorded in a disc.

Blu-ray Disc

This is one-side 1 layer disc having 25 GB capacity and can record high vision video movie and games.

Bonus View

Special images for BD-Videos. It includes comment of the movie director, simultaneously developing sub-story, and images from different angles.

C

Chapter

This is a break intended by a producer who organizes the title of Blu-ray Disc or DVD-Video. The chapter search function searches the beginning of this break.

D

Deep Color

This technology allows expression of more number of colors than the conventional 8 bits and can reproduce colors close to natural ones without color streak.

DHCP (Dynamic Host Configuration Protocol)

This mechanism automatically perform network configuration such as IP address for network devices including the unit, PC, and broadband router.

Dolby Digital

Dolby Digital is a multi-channel digital signal format developed by Dolby Laboratories.

A total of 5.1 channels are played: 3 front channels ("FL" , "FR" and "C"), 2 surround channels ("SL" and "SR") and the "LFE" channel for low frequencies.

Because of this, there is no crosstalk between channels and a realistic sound field with a "three-dimensional" feeling (sense of distance, movement and positioning) is achieved.

A realistic, powerful sense of presence is achieved when playing movie sources in AV rooms as well.

Dolby Digital EX

Dolby Digital EX is a 6.1-channel surround format proposed by Dolby Laboratories that allows users to enjoy in their homes the "DOLBY DIGITAL SURROUND EX" audio format jointly developed by Dolby Laboratories and Lucas Films.

The 6.1 channels of sound, including surround back channels, provide improved sound positioning and expression of space.

Dolby Digital Plus

Dolby Digital Plus is an improved Dolby Digital signal format that is compatible with up to 7.1 channels of discrete digital sound and also improves sound quality thanks to extra data bit rate performance. It is upwardly compatible with conventional Dolby Digital, so it offers greater flexibility in response to the source signal and the conditions of the playback equipment.

Dolby TrueHD

Dolby TrueHD is a high definition audio technology developed by Dolby Laboratories, using lossless coding technology to faithfully reproduce the sound of the studio master.

This format is compatible with a maximum sampling frequency of 96 kHz and up to 7.1 channels, so it is used for applications particularly prioritizing sound quality.

Dolby Pro Logic II

Dolby Pro Logic II is a matrix decoding technology developed by Dolby Laboratories.

Regular music such as that on CDs is encoded into 5 channels to achieve an excellent surround effect. The surround channel signals are converted into stereo and full band signals (with a frequency response of 20 Hz to 20 kHz or greater) to create a "three-dimensional" sound image offering a rich sense of presence for all stereo sources.

Dolby Pro Logic IIx

Dolby Pro Logic IIx is a further improved version of the Dolby Pro Logic g matrix decoding technology. Audio signals recorded in 2 channels are decoded to achieve a natural sound with up to 7.1 channels. There are three modes: "Music" suited for playing music, "Cinema" suited for playing movies, and "Game" which is optimized for playing games.

Dolby Pro Logic IIz

Dolby Pro Logic IIz introduces a new dimension to Home Entertainment through the addition of a pair of front height channels. Compatible with stereo, 5.1-channel and 7.1-channel content, Dolby Pro Logic IIz provides enhanced spaciousness, depth and dimension to movies, concert video and video game playback while maintaining the full integrity of the source mix.

Dolby Pro Logic IIz identifies and decodes spatial cues that occur naturally in all content, directing this information to the front height channels, complementing the performance of left and right surround sound speakers. Content that is encoded with Dolby Pro Logic IIz height channel information can be even more revealing, with perceptually discrete height channel information bringing an exciting new dimension to home entertainment.

Dolby Pro Logic IIz, with front height channels is also an ideal alternative for households that cannot support the placement of back surround speakers of a typical 7.1-channel system but may have bookshelf space available to support the addition of height speakers.

Dolby Virtual Speaker

This is technology from Dolby Laboratories.

It is a surround system using just two speakers to create the effect of surround sound, with sound even coming from behind you as if it was a 5.1-channel system.

Downmix

This function converts the number of channels of surround audio to less number of channels and plays back.

DTS

This is an abbreviation of Digital Theater System, which is a digital audio system developed by DTS. When playing back audio by connecting this system with a device such as DTS amplifier, accurate sound field position and realistic sound effect as if you are in a movie theater can be obtained.

DTS 96/24

DTS 96/24 is a digital audio format enabling high sound quality playback in 5.1 channels with a sampling frequency of 96 kHz and 24 bit quantization on DVD-Video.

DTS Digital Surround

DTS Digital Surround is the standard digital surround format of DTS, Inc., compatible with a sampling frequency of 44.1 or 48 kHz and up to 5.1 channels of digital discrete surround sound.

DTS-ES™ Discrete 6.1

DTS-ES™ Discrete 6.1 is a 6.1-channel discrete digital audio format adding a surround back (SB) channel to the DTS digital surround sound.

Decoding of conventional 5.1-channel audio signals is also possible according to the decoder.

DTS-ES™ Matrix 6.1

DTS-ES™ Matrix 6.1 is a 6.1-channel discrete digital audio format inserting a surround back (SB) channel to the DTS digital surround sound through matrix encoding. Decoding of conventional 5.1-channel audio signals is also possible according to the decoder.

DTS Express

DTS Express is an audio format supporting low bit rates (max. 5.1 channels, 24 to 256 kbps).

Manufactured under license under U.S. Patent #: 5,451,942; 5,956,674; 5,974,380; 5,978,762; 6,226,616; 6,487,535; 7,212,872; 7,333,929; 7,392,195; 7,272,567 & other U.S. and worldwide patents issued & pending. DTS is a registered trademark and the DTS logos, Symbol, DTS-HD and DTS-HD Master Audio are trademarks of DTS, Inc. © 1996-2008 DTS, Inc. All Rights Reserved.

DTS-HD

This audio technology provides higher sound quality and enhanced functionality than the conventional DTS and is adopted as an optional audio for Blu-ray Disc. This technology supports multi-channel, high data transfer speed, high sampling frequency, and lossless audio playback. Maximum 7.1-channels are supported in Blu-ray Disc.

DTS-HD High Resolution Audio

DTS-HD High Resolution Audio is an improved version of the conventional DTS, DTS-ES and DTS 96/24 signals formats, compatible with sampling frequencies of 96 or 48 kHz and up to 7.1 channels of discrete digital sound. High data bit rate performance provides high quality sound. This format is fully compatible with conventional products, including conventional DTS digital surround 5.1-channel data.

DTS-HD Master Audio

DTS-HD Master Audio is DTS, Inc.'s lossless audio format compatible with up to 96 kHz/7.1 channels. The lossless audio coding technology faithfully reproduces the sound of the studio master. It is fully compatible with conventional products, including conventional DTS digital surround 5.1-channel data.

DTS NEO:6™ Surround

DTS NEO:6™ is a matrix decoding technology for achieving 6.1-channel surround playback with 2-channel sources. It includes "DTS NEO:6 Cinema" suited for playing movies and "DTS NEO:6 Music" suited for playing music.

Dynamic range

The difference between the maximum undistorted sound level and the minimum sound level that is discernible above the noise emitted by the device.

F**Finalise**

This is processing that enables playing back of disc of BD/DVD/CD, which was recorded using a recorder, by other players.

H**HDCP**

When transmitting digital signals between devices, this copyright protection technology encrypts the signals to prevent content from being copied without authorization.

HDMI

This is an abbreviation of High-Definition Multimedia Interface, which is an AV digital interface that can be connected to a TV or amplifier. Video signal and audio signal can be connected using 1 cable.

I**Interlacing (interlaced scanning)**

This conventional method used to project images on a TV displays 1 frame of image in half and half, respectively as 2 fields.

Interactive audio

Audio such as click sound that is generated during operation and is recorded in the title of BD-Videos.

J**JPEG (Joint Photo graphic Experts Group)**

This is a still picture data compression standard. Its ability to reduce the size of a file with relatively little deterioration in image quality means that it is widely used for storing images in video cameras, etc.

L**LFE**

This is an abbreviation of Low Frequency Effect, which is an output channel that emphasizes low frequency effect sound. Surround audio is intensified by outputting 20 Hz to 120 Hz deep bass.

Linear PCM

This signal is uncompressed PCM (Pulse Code Modulation) signal. This is the same system as the CD audio but this uses 192 kHz, 96 kHz, and 48 kHz sampling frequencies in Blu-ray Disc or DVD and provides higher sound quality than CD.

M**MP3 (MPEG AudioPlayer 3)**

This is an internationally standardized audio data compression scheme, using the "MPEG-1" video compression standard. It compresses the data volume to about one eleventh its original size while maintaining sound quality equivalent to a music CD.

MPEG (Moving Picture Experts Group), MPEG-2, MPEG-4

These are the names for digital compression format standards used for the encoding of video and audio. Video standards include "MPEG-1 Video", "MPEG-2 Video", "MPEG-4 Visual", "MPEG-4 AVC". Audio standards include "MPEG-1 Audio", "MPEG-2 Audio", "MPEG-4 AAC".

Multi-zone

This is a function for sharing audio and video from an AV device across several rooms.

For example, you could have 5.1-channel surround playing in the MAIN ZONE (the room in which this unit is located) and video and audio from an iPod in ZONE2 (another room).

Getting Started
Simple Version
Connections
Playback (Basic)
Settings
Playback (Advanced)
Multi-zone
GUI
Remote Control
Part Names
Other Information
Troubleshooting
Spec.
Index

P

Picture-in-picture

This BD-Video function allows you to view making or commentary scenes in the secondary video while viewing the main story in the primary video.

Popup menu

This menu recorded in Blu-ray Disc software. While playing back a Blu-ray Disc, this menu can be displayed on the front of the screen and can be operated.

Primary audio

This audio signal is recorded in the main story in BD-Video.

Progressive (sequential scanning)

This is a scanning system of video signal that displays 1 frame of video as one image. Compared to the interlace system, this system provides images with less flickering and bleeding.

Protection Circuit

This is a function to prevent damage to components within the power supply when an abnormality such as an overload or excess voltage occurs for any reason.

In this unit, the power indicator blinks and the unit enters standby mode when an abnormality occurs.

R

Rating

Depending on the age of the viewer, this function restricts playing back of BD-Video or DVD-Video. This unit can be set to restrict viewing in 0 to 254 level for BD-Video, and 1 to 8 level for DVD-Video.

Region code

This code indicates country or region where the Blu-ray Disc or DVD-Video can be played back.

S

Sampling frequency

Sampling involves taking a reading of a sound wave (analog signal) at regular intervals and expressing the height of the wave at each reading in digitized format (producing a digital signal).

The number of readings taken in one second is called the "sampling frequency". The larger the value, the closer the reproduced sound is to the original.

Secondary audio

This is audio signals of comment of movie director and other data recorded in the bonus view of BD-Video.

T

Title

This is the unit of content that consists of chapters of Blu-ray Disc or DVD-Video. Some Blu-ray Disc or DVD-Video may include multiple titles.

W

WMA (Windows Media Audio)

This is audio compression technology developed by Microsoft Corporation.

WMA data can be encoded using Windows Media® Player Ver.7, 7.1, Windows Media® Player for Windows® XP and Windows Media® Player 9 Series.

To encode WMA files, only use applications authorized by Microsoft Corporation. If you use an unauthorized application, the file may not work properly.

X

x.v.Color

This function lets HDTVs display colors more accurately. It enables display with natural, vivid colors. "x.v.Color" is a Sony registered trademark.

Troubleshooting

If a problem should arise, first check the following:

1. Are the connections correct?
2. Is the set being operated as described in the owner's manual?
3. Are the other components operating properly?

If this unit does not operate properly, check the items listed in the table below. Should the problem persist, there may be a malfunction.

In this case, disconnect the power immediately and contact your store of purchase.

[General]

Symptom	Cause/Solution	Page
Power does not turn on.	<ul style="list-style-type: none"> • Check whether the power plug is correctly inserted into the power outlet. • Check whether the power cord is correctly inserted into the AC inlet. • The protection circuit is active. Disconnect the power plug from the electric outlet, wait 5 to 10 seconds and then insert it back into the outlet. 	5 5 5
Display is off.	<ul style="list-style-type: none"> • Set "Dimmer" on the GUI menu to something other than "OFF". 	57
The power indicator is blinking red in intervals of approximately 2 seconds.	<ul style="list-style-type: none"> • The temperature inside the unit has risen. Please turn off power once, and re-apply the power after the temperature has fallen sufficiently. • Please re-install this unit in a place having good ventilation. 	– –
The power indicator is blinking red in intervals of approximately 0.5 seconds.	<ul style="list-style-type: none"> • Please use speakers which have the specified impedance. • The speaker cable has shorted (is touching). Firmly twist the core wire in the speaker cable, and then re-connect it to the speaker terminal. 	4 4
After turning on the power, the power indicator is blinking red in intervals of approximately 0.5 seconds.	<ul style="list-style-type: none"> • The unit amplifier circuit has failed. Turn off the power and please contact the DENON service adviser. 	–
Set does not operate properly.	<ul style="list-style-type: none"> • Reset the microprocessor. 	77
The power turns off or the input source suddenly switches for no reason.	<ul style="list-style-type: none"> • When "HDMI Control" – "Control" on the GUI menu is set to "ON", operation of this unit is linked to the operation of the TV. 	55

[Audio]

Symptom	Cause/Solution	Page
Audio is not output.	<ul style="list-style-type: none"> • Check the connections for all devices. • Check the speaker connections. • Check whether the audio device power is turned on. • Adjust the master volume. • Cancel the mute mode. • Select a suitable input source. • Select a suitable input mode. • Disconnect the headphones. No sound is output from the speakers or the PRE OUT connectors when headphones are connected. 	12 4, 35 5 28 10, 64 20 47 62
No sound is produced from surround back speaker.	• Set "Speaker Assign" on the GUI menu to "5.1CH + Surround Back".	53
	• Set "Speaker Configuration" – "Surround Back" on the GUI menu to something other than "None".	54
	• Set "Surround Parameters" – "Surround Back" on the GUI menu to something other than "OFF".	50
	• Set the surround mode to something other than "STEREO".	31
No sound is produced from front height speaker.	• Set "Audio Adjust" – "Surround Parameters" – "Front Height" on the GUI menu to "ON".	49
	• Set "Manual Setup" – "Speaker Setup" – "Speaker Assign" on the GUI menu to "5.1CH + Front Height".	53
No sound is produced from subwoofer.	• Check the subwoofer connections.	4
	• Turn on the subwoofer's power.	–
	• Set "Subwoofer" on the GUI menu to "Yes".	53
DTS sound is not output.	• Set "Decode Mode" on the GUI menu to "Auto" or "DTS".	47
Dolby TrueHD, DTS-HD, Dolby Digital Plus audio is not output.	• Make HDMI connections.	12
HD audio is not output.	• Set "BD Audio Mode" on the MODE menu to "HD Audio Output".	58
Audio input to the COAXIAL connector is not output.	• Set "Manual Setup" – "Audio Setup" – "COAX Input Assign" on the GUI menu to "AUX1" or "AUX2".	56
Audio input to the OPTICAL connector is not output.	• Set "Source Select" – "Input Mode" on the GUI menu to "Auto" or "Digital".	47
	• Set "Manual Setup" – "Audio Setup" – "COAX Input Assign" on the GUI menu to "OFF".	56

[Video]

Symptom	Cause/Solution	Page
No picture appears.	<ul style="list-style-type: none"> • Check the TV connection. • Set the TV input correctly. 	12, 13 –
No picture appears, the picture is disrupted, or the Blu-ray disc or DVD video picture appears in black and white.	• The picture may be slightly disturbed directly after fast-forwarding or reversing. This is not a malfunction.	29
	• Discs not compatible with this unit, or discs with different region codes, cannot be played back. The region codes compatible with this unit include "A" for BD-Video and "1" or "ALL" for DVD video.	19
Picture quality has deteriorated.	When ZONE2 is powered on, the HDMI video resolution in the MAIN ZONE switches automatically according to the input signal.	13, 41

[HDMI]

Symptom	Cause/Solution	Page
No audio is output with HDMI connection.	• Check the connection of the HDMI connectors.	12
	• When outputting HDMI audio from the speakers, set "HDMI Audio Out" on the GUI menu to "AMP".	55
	• When outputting HDMI audio from a TV, set "HDMI Audio Out" on the GUI menu to "TV".	55
No video is output with HDMI connection.	• Check the connection of the HDMI connectors.	12
	• Set the input source to match the connected HDMI connector.	20
When the following operations are performed on devices compatible with HDMI control, the same operations occur on this unit. • Power ON/OFF • Switching audio output devices • Adjust volume • Switch input source	• Check whether the TV is compatible with copyright protection (HDCP). If connected to a device not compatible with HDCP, video will not be output correctly.	–
	• Check whether the HDMI video resolution set in this unit is compatible with the TV resolution. If set to "Auto", this unit sets it automatically.	13
	• Set "HDMI Control" – "Control" on the GUI menu to "OFF". To operate power only for each device, set "Power Off Control" to "OFF".	55

Getting Started
Simple Version
Connections
Playback (Basic)
Settings
Playback (Advanced)
Multi-zone
GUI
Remote Control
Part Names
Other Information
Troubleshooting
Spec.
Index



Getting Started
Simple Version
Connections
Playback (Basic)
Settings
Playback (Advanced)
Multi-zone
GUI
Remote Control
Part Names
Other Information
Troubleshooting
Spec.
Index

[Blu-ray Disc]

Symptom	Cause/Solution	Page
Picture freezes momentarily during playback.	<ul style="list-style-type: none"> The disc may not play back correctly if it is scratched or dirty. Either clean the disc or replace it. There may be a problem with the recorded disc. 	–
Playback does not start even when ► is pressed, or starts but stops immediately.	<ul style="list-style-type: none"> Check whether there is condensation on the inside of the unit or disc. If there is condensation, turn off the power and let the unit stand for 1 to 2 hours. 	2
	<ul style="list-style-type: none"> The disc may not play back correctly if it is scratched or dirty. Either clean the disc or replace it. 	66
	<ul style="list-style-type: none"> Check whether the disc has been inserted upside down. Insert the disc so that the recording surface to be played back faces downward. Check whether a disc that cannot be played back on this unit has been inserted. 	65 19
Subtitles are not displayed.	<ul style="list-style-type: none"> Subtitles cannot be displayed for BD-Video or DVD-Video that do not contain subtitles. 	31
	<ul style="list-style-type: none"> Check whether the subtitles setting is set to "OFF". 	44
Wallpaper is not displayed even after the disc has been removed.	<ul style="list-style-type: none"> An internal error may have occurred in the unit. Set the power to standby, wait awhile, then turn the power back on. 	–
Button operation does not work. The unit fails to operate.	<ul style="list-style-type: none"> Operations may not be permitted by the disc. Refer to the instructions of the disc. 	65
	<ul style="list-style-type: none"> The protection circuit is active. In this case, disconnect the power plug from the electric outlet, wait 5 to 10 seconds and then insert it back into the outlet. 	74
The unit fails to read the disc.	<ul style="list-style-type: none"> The pickup lens may be dirty. Use a commercially available lens cleaner to clean the laser pickup. Avoid use of cleaners equipped with brushes, since they may scratch the lens. 	–
Angle does not switch.	<ul style="list-style-type: none"> If a BD-Video or DVD-Video does not record multiple angles, angle cannot be switched. Also, multiple angles may be recorded for specific scenes. 	30
Playback does not start when the title is selected.	<ul style="list-style-type: none"> Playback may be prohibited by the viewing restriction setting. Check "Ratings" on the GUI menu. 	45
The password for rating level has been forgotten.	<ul style="list-style-type: none"> Reset the microprocessor. 	77

[Radio]

Symptom	Cause/Solution	Page
Reception fails, or there is a lot of noise or distortion.	<ul style="list-style-type: none"> Change the antenna orientation or position. 	15
	<ul style="list-style-type: none"> Separate the AM loop antenna from the unit. 	15
	<ul style="list-style-type: none"> Use an FM outdoor antenna. 	15
	<ul style="list-style-type: none"> Separate the antenna from other connection cables. 	15

[SD memory card]

Symptom	Cause/Solution	Page
Unable to play back bonus view.	<ul style="list-style-type: none"> Check that capacity on the SD memory card is 1 GB or more. 	19
	<ul style="list-style-type: none"> Initialize the SD memory card on this unit. 	46
	<ul style="list-style-type: none"> Was the SD memory card mounted while the power was turned on? Mount the SD memory card while in Standby state. 	19
SD memory card cannot be read.	<ul style="list-style-type: none"> An incompatible SD memory card may have been inserted, or the recording format may not be compatible with the unit, preventing recognition. 	19

[USB memory device]

Symptom	Cause/Solution	Page
When a USB memory device is connected, "USB" is not displayed on the GUI menu.	<ul style="list-style-type: none"> The set cannot recognize a USB memory device. Check the connection. 	14
	<ul style="list-style-type: none"> A USB memory device not conforming to mass storage class is connected. Connect a USB memory device conforming to mass storage class. 	19
	<ul style="list-style-type: none"> A USB memory device cannot be connected via a USB hub. 	14
Files on a USB memory device cannot be played.	<ul style="list-style-type: none"> Set the USB memory device format to "FAT16" or "FAT32". For details, refer to the USB memory device's operating instructions. 	19
	<ul style="list-style-type: none"> If the USB memory device is divided into multiple partitions, only files stored in the top partition can be played. 	–
	<ul style="list-style-type: none"> The file is recorded in an incompatible format. Please record it in a compatible format. This unit cannot play back files covered by copyright protection. 	19 12
The sound quality is poor or there is noise during playback.	<ul style="list-style-type: none"> The file being played back has a low bit rate. 	–
"Connection Error" is displayed.	<ul style="list-style-type: none"> Unable to communicate properly. Turn off the power to this unit, unplug the USB memory device and then plug it back in. 	–
"Communication Error" is displayed.	<ul style="list-style-type: none"> The USB memory device is not responding. Turn off the power to this unit, unplug the USB memory device and then plug it back in. 	–
"Overcurrent" is displayed.	<ul style="list-style-type: none"> The USB memory device is consuming too much power. When using a USB portable hard disk that can be powered by an AC adapter, connect its AC adapter. 	–



[iPod]

Symptom	Cause/Solution	Page
iPod cannot be played.	<ul style="list-style-type: none"> • Check the iPod connections. • Plug the control dock for iPod's AC adapter into a power outlet. • Switch the input source to "AUX1". • If using an iPod connected to the USB terminal, incompatible iPod types cannot be played back. 	14 – 20 14
The file names are not displayed properly ("...", etc.).	<ul style="list-style-type: none"> • Characters that cannot be displayed on this unit are replaced by "*". 	22
"Connection Error" is displayed.	<ul style="list-style-type: none"> • Unable to communicate properly. Turn off the power to this unit, disconnect the iPod and then reconnect it. 	–
"Not Support" is displayed.	<ul style="list-style-type: none"> • The iPod connected to the unit is not compatible. Please make sure the iPod you are connecting is compatible. • The software version of the connected iPod is an old one. Please update to the latest version. 	14 –
"Communication Error" is displayed.	<ul style="list-style-type: none"> • The iPod is not responding. Turn off the power to this unit, disconnect the iPod and then reconnect it. 	–

[Remote Control Unit]

Symptom	Cause/Solution	Page
The set cannot be operated with the remote control unit.	<ul style="list-style-type: none"> • Batteries are worn out. Replace with new batteries. 	65
	<ul style="list-style-type: none"> • Operate the remote control unit within a distance of about 23 feet/7 m from this unit and at an angle of within 30°. 	65
	<ul style="list-style-type: none"> • Remove any obstacle between this unit and the remote control unit. 	–
	<ul style="list-style-type: none"> • Insert the batteries in the proper direction, checking the ⊕ and ⊖ marks. 	65
	<ul style="list-style-type: none"> • The set's remote control sensor is exposed to strong light (direct sunlight, inverter type fluorescent bulb light, etc.). Move the set to a place in which the remote control sensor will not be exposed to strong light. 	–
	<ul style="list-style-type: none"> • Set the remote control unit's device selection switch properly. 	59

NOTE

- Some function may not be used in some operation status and this is not failure of the unit. Read the description in this Owner's Manual for details on correct operations.
- The volume may differ from disc to disc. This is due to the differences in how the signals are recorded on the disc, and is not a malfunction.
- Some functions are prohibited on some discs.

Resetting the Microprocessor

Perform this procedure if the display is abnormal or if operations cannot be performed. When the microprocessor is reset, all the settings are reset to their default values.

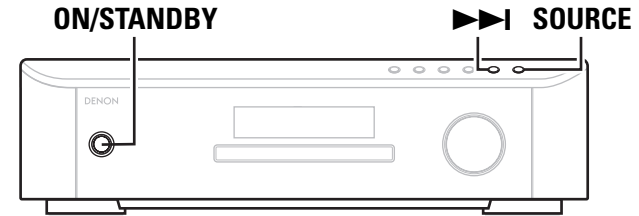

1 During standby, press **ON/STANDBY** while pressing **▶▶** and **SOURCE** simultaneously.

2 Once the display starts flashing at intervals of about 1 second, release the two buttons.

After "INITIALIZED" is displayed on the screen, the "FIRST SETUP" screen is displayed automatically.



If in step 2 the display does not flash at intervals of about 1 second, start over from step 1.

Attaching the Door

If the door on the front panel comes off, reattach it as shown below.

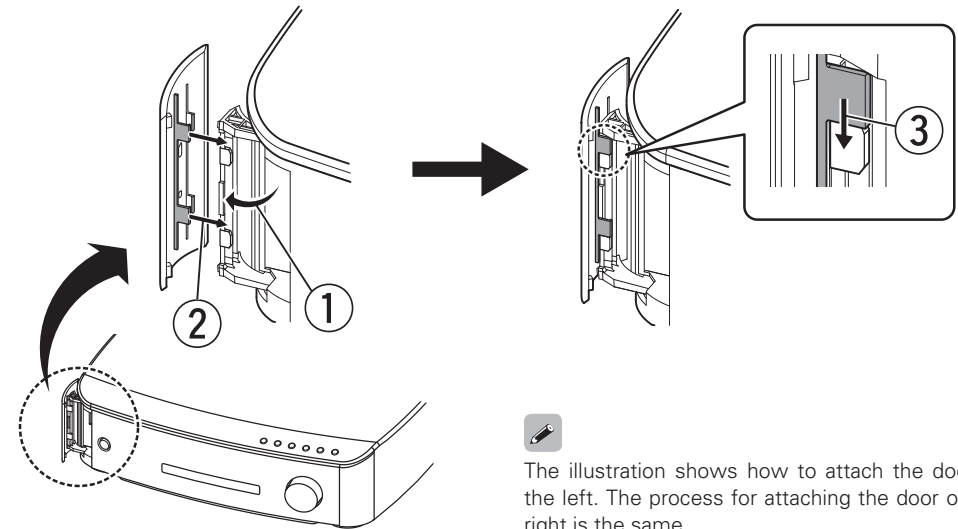

The illustration shows how to attach the door on the left. The process for attaching the door on the right is the same.

Getting Started
Simple Version
Connections
Playback (Basic)
Settings
Playback (Advanced)
Multi-zone
GUI
Remote Control
Part Names
Other Information
Troubleshooting
Spec.
Index



Index

Numerics

2.1-channel	31, 34, 36
4:3 LB (letterbox)	44, 72
4:3 PS (pan scan)	44, 72
5.1-channel	4
6.1-channel	34, 35
7.1-channel	34, 35

A

AAC	19, 72
Accessories	1
AFDM	49
AL24 Processing	63, 67
AM loop antenna	15
Angle	30
ARC function	12
Aspect ratio	44, 72
Attaching the door	77
Audio Adjust	48, 68
Audio cable	4, 13, 15
Audio commentary	30, 72
Audio Delay	52
Audio Setup	56
Audyssey Auto Setup	6, 36, 52
Audyssey Dynamic EQ	51, 72
Audyssey Dynamic Volume	52, 72
Audyssey MultEQ	63, 72
Audyssey Settings	51
Auto Format	44
Auto Preset	48
Auto Setup	52
AVCHD	19, 72

B

Bass	50
Bass Setting	54
BD-J (Blu-ray Disc Java)	28, 72
BD-LIVE	21, 72
BD-Video	19, 66
BD Audio Mode	58
BD Data Utility	46
BD Rating Level	45
Bit rate	19, 72
Blu-ray Disc	20, 66, 72
Bonus View	21, 72
Browse mode	22, 23

C

Cable	
Audio cable	4, 13, 15
Coaxial digital cable	13, 14, 15
Ethernet cable	16
HDMI cable	5, 12
Optical cable	13, 15
Speaker cable	4
Captions	46
CD-R	19, 66
CD-RW	19, 66
Center Image	49
Center Width	49
Channel Level	55
Chapter	66, 72
Chapter search	18, 37
Cinema EQ	49
Coaxial digital cable	13, 14, 15
COAX Input Assign	56
Condensation	2
Connection	
Antenna	15
Cable TV	15
Control dock for iPod	14
Digital camcorder	12
Digital video recorder	12
Game device	12
HDMI	12
iPod (USB)	14
Network	16
Power cord	5
REMOTE CONTROL	17
RS-232C	17
Satellite tuner	12, 15
Set-top box	15
Speaker	4, 35
TRIGGER OUT	17
TV	5, 12, 13
USB memory device	14
Copyright protection	67
Country code	71
Crossover Frequency	55

D

D.COMP	49
Decode Mode	47
Deep Color	12, 44, 72
DEVICE SELECT	64
DHCP	45, 72
Dialog	44
Dimension	49
Dimmer	57

Dimmer Sensor	57
Disc Layer	46
Disc Menus	44
Disc Mode	25
Display	62
Display Setup	46
Distance	54
Dolby	
Dolby Digital	32, 72
Dolby Digital EX	32, 72
Dolby Digital Plus	32, 72
Dolby PLII (Dolby Pro Logic II)	32, 72
Dolby PLIIx (Dolby Pro Logic IIx)	32, 72
DOLBY PLIIz (Dolby Pro Logic IIz)	32, 34, 73
Dolby TrueHD	32, 72
Dolby Virtual Speaker	31, 73
Downmix	73
DRC	49
DTS	32, 73
DTS-ES Discrete 6.1	32, 73
DTS-ES Matrix 6.1	32, 73
DTS-HD	32, 73
DTS-HD High Resolution Audio	73
DTS-HD Master Audio	73
DTS 96/24	32, 73
DTS Digital Surround	73
DTS Express	73
DTS NEO:6	32
DTS NEO:6™ Surround	73
DVD+R	19, 66
DVD+RW	19, 66
DVD-R	19, 66
DVD-RW	19, 66
DVD-Video	19, 20, 66
DVD Rating Level	45
Dynamic EQ	51
Dynamic Play Mode	56
Dynamic range	73
Dynamic Volume	52

E

Error messages	9
Ethernet cable	16

F

Fast forward	29
Fast reverse	29
File	19, 25, 66
File filter	58
Finalise	73
Firmware Update	46
FIRST SETUP	6, 36

Folder	66
Front Height	49, 54
Front Height Speaker	34, 35
Front Panel	62

G

GUI	56
GUI Language	5, 57
GUI menu operation	43

H

HDCP	12, 73
HDMI	12, 73
HDMI Audio Out	55
HDMI cable	5, 12
HDMI Control	39, 55
HDMI Setup	55
HDMI version 1.3a	12
HDMI version 1.4	12
HDMI video resolution	13
Headphones	62

I

Indicator	62
Information	46, 57
Audio Input Signal	57
Auto Surround Mode	58
HDMI Information	57
Preset Channel	58
Status	57
Input Mode	47
Input signal	32, 69
Inserting a disc	65
Interactive audio	30, 73
Interlacing	13, 73
IP Address	45

J

JPEG	19, 26, 73
------	------------

L

Language code	70
Language Setup	44
LFE	49, 73
LPCM (Linear PCM)	19, 73

Getting Started
Simple Version
Connections
Playback (Basic)
Settings
Playback (Advanced)
Multi-zone
GUI
Remote Control
Part Names
Other Information
Troubleshooting
Spec.
Index

M
MAC Address..... 45
MAIN ZONE..... 41
Manual Setup..... 53
Marker function..... 38
Marker search..... 37
Master Volume..... 56
Menu map..... 42
microSD card..... 19
miniSD card..... 19
Mode..... 48
MP3..... 19, 73
MPEG..... 73
MultEQ..... 51
Multi-channel source..... 32
Multi-zone..... 41, 73
MUTE..... 62, 64
N
Network Setup..... 45
O
One touch play..... 39
Operation
Fast forward..... 29
Fast reverse..... 29
Pause..... 28
Random..... 29
Repeat..... 29
Shuffle (iPod)..... 24
Skip..... 29
Slow forward..... 29
Slow reverse..... 29
Step-by-step..... 28
Stop..... 28
Optical cable..... 13, 15
Option Setup..... 56
Dimmer..... 57
Dimmer Sensor..... 57
GUI..... 56
Quick Start Mode..... 56
Remote Preset Codes..... 56
Setup Lock..... 57
Trigger Out..... 56
Volume Control..... 56
Other Setup..... 46
BD Data Utility..... 46
Firmware Update..... 46
Information..... 46

P
Panorama..... 49
Parameter Check..... 52
Password..... 45
Pause..... 28
Picture-in-picture..... 21, 74
Playable cards..... 19
Playable discs..... 19
Playable files..... 19
Playback
AAC..... 25
Blu-ray Disc..... 20
CD..... 21
DVD..... 20
FM/AM broadcasts..... 27
iPod (Control dock for iPod)..... 22
iPod (USB)..... 23
JPEG..... 26
LPCM..... 25
MP3..... 25
USB memory device..... 24
WMA..... 25
Playback mode (Disc/Folder)..... 25
Play Mode..... 58
Popup menu..... 74
Power Off Control..... 55
Preset codes..... 56, 59
Preset Name..... 48
Presetting radio stations..... 27
Primary audio..... 30, 74
Progressive..... 13, 74
Progressive Mode..... 44
Protection circuit..... 74
Proxy..... 45
Q
Quick Start Mode..... 56
R
Random..... 29
Rating Country Code..... 45
Ratings..... 45
Rear panel..... 63
Reference Level Offset..... 51
Region code..... 19, 74
Remote control unit..... 59, 64
Inserting the batteries..... 65
Operating components..... 59
Registering Preset Codes..... 59
Remote mode..... 22, 23
Remote Preset Codes..... 56
Rename..... 47

Repeat..... 29
Resetting the microprocessor..... 77
RESTORER..... 26
Resume function..... 28
S
Sampling frequency..... 19, 74
Screensaver..... 56
SD CARD slot..... 62
SDHC memory card..... 19
SD memory card..... 19, 66
SD Mode..... 25
Search mode..... 37
Chapter search..... 18, 37
Marker search..... 37
Time search..... 37
Title search..... 18, 37
Track search..... 37
Secondary audio..... 30, 74
Selecting the input source..... 20
Setting (Audyssey)..... 52
Setup Lock..... 57
Set up the subwoofer..... 7
Shuffle (iPod)..... 24
Skip..... 29
Sleep timer..... 40
Slide Show Time..... 46
Slow forward..... 29
Slow reverse..... 29
Source Select..... 20, 47
Speaker
Connect..... 4, 35
Install..... 4, 34
Set up..... 6, 36
Speaker Assign..... 53
Speaker cable..... 4
Speaker Configuration..... 53
Speaker Setup..... 53
Standby Source..... 55
Step-by-step..... 28
Still Mode..... 46
Stop..... 28
Subtitle..... 31, 44
Surround Back..... 50, 54
Surround back speaker..... 34, 35
Surround Mode..... 31, 68
Surround Parameters..... 48
Switching audio..... 30
Switching the display page..... 24

T
Thumbnail screen..... 26
Time search..... 37
Title..... 66, 74
Title search..... 18, 37
Tone Control..... 50
Top Panel..... 62
Track..... 66
Track search..... 37
Trademark..... 67
Treble..... 50
Trigger Out..... 56
Turn off power (standby)..... 10
Turn on power..... 5
TV Aspect..... 44
V
Video Setup..... 44
Volume..... 28
Volume Control..... 56
Volume Limit..... 56
W
WMA..... 19, 74
X
x.v.Color..... 12, 74
Z
ZONE2..... 41, 63

License / Licence / License

This section describes software license used for this unit. To maintain the correct content, the original (English) is used.

Cette section concerne la licence du logiciel utilisé pour cet appareil. Le document d'origine (en anglais) est utilisé afin d'assurer l'exactitude du contenu.

Esta sección describe el contenido de la licencia del software para esta unidad. Para mantener el contenido correcto, se utiliza el original (Inglés).

□ Exhibit-A

GNU GENERAL PUBLIC LICENSE

Version 2, June 1991

Copyright (C) 1989, 1991

Free Software Foundation, Inc. 59 Temple Place, Suite 330, Boston, MA 02111-1307 USA

Everyone is permitted to copy and distribute verbatim copies of this license document, but changing it is not allowed.

Preamble

The licenses for most software are designed to take away your freedom to share and change it. By contrast, the GNU General Public

License is intended to guarantee your freedom to share and change free software—to make sure the software is free for all its users. This General Public License applies to most of the Free Software Foundation's software and to any other program whose authors commit to using it. (Some other Free Software Foundation software is covered by the GNU Library General Public License instead.) You can apply it to your programs, too.

When we speak of free software, we are referring to freedom, not price. Our General Public Licenses are designed to make sure that you have the freedom to distribute copies of free software (and charge for this service if you wish), that you receive source code or can get it if you want it, that you can change the software or use pieces of it in new free programs; and that you know you can do these things.

To protect your rights, we need to make restrictions that forbid anyone to deny you these rights or to ask you to surrender the rights. These restrictions translate to certain responsibilities for you if you distribute copies of the software, or if you modify it.

For example, if you distribute copies of such a program, whether gratis or for a fee, you must give the recipients all the rights that you have. You must make sure that they, too, receive or can get the source code. And you must show them these terms so they know their rights.

We protect your rights with two steps: (1) copyright the software, and (2) offer you this license which gives you legal permission to copy, distribute and/or modify the software.

Also, for each author's protection and ours, we want to make certain that everyone understands that there is no warranty for this free software. If the software is modified by someone else and passed on, we want its recipients to know that what they have is not the original, so that any problems introduced by others will not reflect on the original authors' reputations.

Finally, any free program is threatened constantly by software patents. We wish to avoid the danger that redistributors of a free program will individually obtain patent licenses, in effect making the program proprietary. To prevent this, we have made it clear that any patent must be licensed for everyone's free use or not licensed at all.

The precise terms and conditions for copying, distribution and modification follow.

TERMS AND CONDITIONS FOR COPYING, DISTRIBUTION AND MODIFICATION

0. This License applies to any program or other work which contains a notice placed by the copyright holder saying it may be distributed under the terms of this General Public License. The "Program", below, refers to any such program or work, and a "work based on the Program" means either the Program or any derivative work under copyright law; that is to say, a work containing the Program or a portion of it, either verbatim or with modifications and/or translated into another language. (Hereinafter, translation is included without limitation in the term "modification.") Each licensee is addressed as "you".

Activities other than copying, distribution and modification are not covered by this License; they are outside its scope. The act of running the Program is not restricted, and the output from the Program is covered only if its contents constitute a work based on the Program (independent of having been made by running the Program). Whether that is true depends on what the Program does.

1. You may copy and distribute verbatim copies of the Program's source code as you receive it, in any medium, provided that you conspicuously and appropriately publish on each copy an appropriate copyright notice and disclaimer of warranty; keep intact all the notices that refer to this License and to the absence of any warranty; and give any other recipients of the Program a copy of this License along with the Program.

You may charge a fee for the physical act of transferring a copy, and you may at your option offer warranty protection in exchange for a fee.

2. You may modify your copy or copies of the Program or any portion of it, thus forming a work based on the Program, and copy and distribute such modifications or work under the terms of Section 1 above, provided that you also meet all of these conditions:

- You must cause the modified files to carry prominent notices stating that you changed the files and the date of any change.
- You must cause any work that you distribute or publish, that in whole or in part contains or is derived from the Program or any part thereof, to be licensed as a whole at no charge to all third parties under the terms of this License.
- If the modified program normally reads commands interactively when run, you must cause it, when started running for such interactive use in the most ordinary way, to print or display an announcement including an appropriate copyright notice and a notice that there is no warranty (or else, saying that you provide a warranty) and that users may redistribute the program under these conditions, and telling the user how to

view a copy of this License.

(Exception: if the Program itself is interactive but does not normally print such an announcement, your work based on the Program is not required to print an announcement.)

These requirements apply to the modified work as a whole. If identifiable sections of that work are not derived from the Program, and can be reasonably considered independent and separate works in themselves, then this License, and its terms, do not apply to those sections when you distribute them as separate works. But when you distribute the same sections as part of a whole which is a work based on the Program, the distribution of the whole must be on the terms of this License, whose permissions for other licensees extend to the entire whole, and thus to each and every part regardless of who wrote it.

Thus, it is not the intent of this section to claim rights or contest your rights to work written entirely by you; rather, the intent is to exercise the right to control the distribution of derivative or collective works based on the Program.

In addition, mere aggregation of another work not based on the Program with the Program (or with a work based on the Program) on a volume of a storage or distribution medium does not bring the other work under the scope of this License.

3. You may copy and distribute the Program (or a work based on it, under Section 2) in object code or executable form under the terms of Sections 1 and 2 above provided that you also do one of the following:

- Accompany it with the complete corresponding machine-readable source code, which must be distributed under the terms of Sections 1 and 2 above on a medium customarily used for software interchange; or,
- Accompany it with a written offer, valid for at least three years, to give any third party, for a charge no more than your cost of physically performing source distribution, a complete machine-readable copy of the corresponding source code, to be distributed under the terms of Sections 1 and 2 above on a medium customarily used for software interchange; or,
- Accompany it with the information you received as to the offer to distribute corresponding source code. (This alternative is allowed only for noncommercial distribution and only if you received the program in object code or executable form with such an offer, in accord with Subsection b above.)

The source code for a work means the preferred form of the work for making modifications to it. For an executable work, complete source code means all the source code for all modules it contains, plus any associated interface definition files, plus the scripts used to control compilation and installation of the executable.

However, as a special exception, the source code distributed need not include anything that is normally distributed (in either source or binary form) with the major components (compiler, kernel, and so on) of the operating system on which the executable runs, unless that component itself accompanies the executable.

If distribution of executable or object code is made by offering access to copy from a designated place, then offering equivalent access to copy the source code from the same place counts as distribution of the source code, even though third parties are not compelled to copy the source along with the object code.

- You may not copy, modify, sublicense, or distribute the Program except as expressly provided under this License. Any attempt otherwise to copy, modify, sublicense or distribute the Program is void, and will automatically terminate your rights under this License. However, parties who have received copies, or rights, from you under this License will not have their licenses terminated so long as such parties remain in full compliance.
- You are not required to accept this License, since you have not signed it. However, nothing else grants you permission to modify or distribute the Program or its derivative works. These actions are prohibited by law if you do not accept this License. Therefore, by modifying or distributing the Program (or any work based on the Program), you indicate your acceptance of this License to do so, and all its terms and conditions for copying, distributing or

modifying the Program or works based on it.

6. Each time you redistribute the Program (or any work based on the Program), the recipient automatically receives a license from the original licensor to copy, distribute or modify the Program subject to these terms and conditions. You may not impose any further restrictions on the recipients' exercise of the rights granted herein.

You are not responsible for enforcing compliance by third parties to this License.

7. If, as a consequence of a court judgment or allegation of patent infringement or for any other reason (not limited to patent issues), conditions are imposed on you (whether by court order, agreement or otherwise) that contradict the conditions of this License, they do not excuse you from the conditions of this License. If you cannot distribute so as to satisfy simultaneously your obligations under this License and any other pertinent obligations, then as a consequence you may not distribute the Program at all. For example, if a patent license would not permit royalty-free redistribution of the Program by all those who receive copies directly or indirectly through you, then the only way you could satisfy both it and this License would be to refrain entirely from distribution of the Program.

If any portion of this section is held invalid or unenforceable under any particular circumstance, the balance of the section is intended to apply and the section as a whole is intended to apply in other circumstances.

It is not the purpose of this section to induce you to infringe any patents or other property right claims or to contest validity of any such claims; this section has the sole purpose of protecting the integrity of the free software distribution system, which is implemented by public license practices. Many people have made generous contributions to the wide range of software distributed through that system in reliance on consistent application of that system; it is up to the author/donor to decide if he or she is willing to distribute software through any other system and a licensee cannot impose that choice.

This section is intended to make thoroughly clear what is believed to be a consequence of the rest of this License.

8. If the distribution and/or use of the Program is restricted in certain countries either by patents or by copyrighted interfaces, the original copyright holder who places the Program under this License may add an explicit geographical distribution limitation excluding those countries, so that distribution is permitted only in or among countries not thus excluded. In such case, this License incorporates the limitation as if written in the body of this License.

9. The Free Software Foundation may publish revised and/or new versions of the General Public License from time to time. Such new versions will be similar in spirit to the present version, but may differ in detail to address new problems or concerns.

Each version is given a distinguishing version number. If the Program specifies a version number of this License which applies to it and "any later version", you have the option of following the terms and conditions either of that version or of any later version published by the Free Software Foundation. If the Program does not specify a version number of this License, you may choose any version ever published by the Free Software Foundation.

10. If you wish to incorporate parts of the Program into other free programs whose distribution conditions are different, write to the author to ask for permission. For software which is copyrighted by the Free Software Foundation, write to the Free Software Foundation; we sometimes make exceptions for this. Our decision will be guided by the two goals of preserving the free status of all derivatives of our free software and of promoting the sharing and reuse of software generally.

NO WARRANTY

11. BECAUSE THE PROGRAM IS LICENSED FREE OF CHARGE, THERE IS NO WARRANTY FOR THE PROGRAM, TO THE EXTENT PERMITTED BY APPLICABLE LAW. EXCEPT WHEN OTHERWISE STATED IN WRITING THE COPYRIGHT HOLDERS AND/OR OTHER PARTIES PROVIDE THE PROGRAM "AS IS" WITHOUT

WARRANTY OF ANY KIND, EITHER EXPRESSED OR IMPLIED, INCLUDING, BUT NOT LIMITED TO, THE IMPLIED WARRANTIES OF MERCHANTABILITY AND FITNESS FOR A PARTICULAR PURPOSE. THE ENTIRE RISK AS TO THE QUALITY AND PERFORMANCE OF THE PROGRAM IS WITH YOU. SHOULD THE PROGRAM PROVE DEFECTIVE, YOU ASSUME THE COST OF ALL NECESSARY SERVICING, REPAIR OR CORRECTION.

12. IN NO EVENT UNLESS REQUIRED BY APPLICABLE LAW OR AGREED TO IN WRITING WILL ANY COPYRIGHT HOLDER, OR ANY OTHER PARTY WHO MAY MODIFY AND/OR REDISTRIBUTE THE PROGRAM AS PERMITTED ABOVE, BE LIABLE TO YOU FOR DAMAGES, INCLUDING ANY GENERAL, SPECIAL, INCIDENTAL OR CONSEQUENTIAL DAMAGES ARISING OUT OF THE USE OR INABILITY TO USE THE PROGRAM (INCLUDING BUT NOT LIMITED TO LOSS OF DATA OR DATA BEING RENDERED INACCURATE OR LOSSES SUSTAINED BY YOU OR THIRD PARTIES OR A FAILURE OF THE PROGRAM TO OPERATE WITH ANY OTHER PROGRAMS), EVEN IF SUCH HOLDER OR OTHER PARTY HAS BEEN ADVISED OF THE POSSIBILITY OF SUCH DAMAGES.

END OF TERMS AND CONDITIONS

How to Apply These Terms to Your New Programs

If you develop a new program, and you want it to be of the greatest possible use to the public, the best way to achieve this is to make it free software which everyone can redistribute and change under these terms.

To do so, attach the following notices to the program. It is safest to attach them to the start of each source file to most effectively convey the exclusion of warranty; and each file should have at least the "copyright" line and a pointer to where the full notice is found.

<one line to give the program's name and a brief idea of what it does.>

Copyright (C) <year> <name of author>

This program is free software; you can redistribute it and/or modify it under the terms of the GNU General Public License as published by the Free Software Foundation; either version 2 of the License, or (at your option) any later version.

This program is distributed in the hope that it will be useful, but WITHOUT ANY WARRANTY; without even the implied warranty of MERCHANTABILITY or FITNESS FOR A PARTICULAR PURPOSE. See the GNU General Public License for more details.

You should have received a copy of the GNU General Public License along with this program; if not, write to the Free Software Foundation, Inc., 59 Temple Place, Suite 330, Boston, MA 02111-1307 USA

Also add information on how to contact you by electronic and paper mail.

If the program is interactive, make it output a short notice like this when it starts in an interactive mode:

Gnomovision version 69, Copyright (C) year name of author

Gnomovision comes with ABSOLUTELY NO WARRANTY; for details type 'show w'. This is free software, and you are welcome to redistribute it under certain conditions; type 'show c' for details.

The hypothetical commands 'show w' and 'show c' should show the appropriate parts of the General Public License. Of course, the commands you use may be called something other than 'show w' and 'show c'; they could even be mouse-clicks or menu items—whatever suits your program.

You should also get your employer (if you work as a programmer) or your school, if any, to sign a "copyright disclaimer" for the program, if necessary. Here is a sample; alter the names:

Yoyodyne, Inc., hereby disclaims all copyright interest in the program 'Gnomovision' (which makes passes at compilers) written by James Hacker.

<signature of Ty Coon>, 1 April 1989

Ty Coon, President of Vice

This General Public License does not permit incorporating your program into proprietary programs. If your program is a subroutine library, you may consider it more useful to permit linking proprietary applications with the library. If this is what you want to do, use the GNU Library General Public License instead of this License.

□ Exhibit-B

GNU LESSER GENERAL PUBLIC LICENSE

Version 2.1, February 1999

Copyright (C) 1991, 1999 Free Software Foundation, Inc.
59 Temple Place, Suite 330, Boston, MA 02111-1307 USA

Everyone is permitted to copy and distribute verbatim copies of this license document, but changing it is not allowed.

[This is the first released version of the Lesser GPL. It also counts as the successor of the GNU Library Public License, version 2, hence the version number 2.1.]

Preamble

The licenses for most software are designed to take away your freedom to share and change it. By contrast, the GNU General Public Licenses are intended to guarantee your freedom to share and change free software—to make sure the software is free for all its users.

This license, the Lesser General Public License, applies to some specially designated software packages—typically libraries—of the Free Software Foundation and other authors who decide to use it. You can use it too, but we suggest you first think carefully about whether this license or the ordinary General Public License is the better strategy to use in any particular case, based on the explanations below.

When we speak of free software, we are referring to freedom of use, not price. Our General Public Licenses are designed to make sure that you have the freedom to distribute copies of free software (and charge for this service if you wish); that you receive source code or can get it if you want it; that you can change the software and use pieces of it in new free programs; and that you are informed that you can do these things.

To protect your rights, we need to make restrictions that forbid distributors to deny you these rights or to ask you to surrender these rights. These restrictions translate to certain responsibilities for you if you distribute copies of the library or if you modify it.

For example, if you distribute copies of the library, whether gratis or for a fee, you must give the recipients all the rights that we gave you. You must make sure that they, too, receive or can get the source code. If you link other code with the library, you must provide complete object files to the recipients, so that they can relink them with the library after making changes to the library and recompiling it. And you must show them these terms so they know their rights. We protect your rights with a two-step method: (1) we copyright the library, and (2) we offer you this license, which gives you legal permission to copy, distribute and/or modify the library.

To protect each distributor, we want to make it very clear that there is no warranty for the free library. Also, if the library is modified by someone else and passed on, the recipients should know that what they have is not the original version, so that the original author's reputation will not be affected by problems that might be introduced by others.

Finally, software patents pose a constant threat to the existence of any free program. We wish to make sure that a company cannot effectively restrict the users of a free program by obtaining a restrictive license from a patent holder. Therefore, we insist that any patent license obtained for a version of the library must be consistent with the full freedom of use specified in this license.

Most GNU software, including some libraries, is covered by the ordinary GNU General Public License. This license, the GNU Lesser General Public License, applies to certain designated libraries, and is quite different from the ordinary General Public License. We use this license for certain libraries in order to permit linking those libraries into non-free programs.

When a program is linked with a library, whether statically or using a shared library, the combination of the two is legally speaking a combined work, a derivative of the original library. The ordinary General Public License therefore permits such linking only if the entire combination fits its criteria of freedom. The Lesser General Public License permits more lax criteria for linking other code with the library.

We call this license the "Lesser" General Public License because it does Less to protect the user's freedom than the ordinary General Public License. It also provides other free software developers Less of an advantage over competing non-free programs. These disadvantages are the reason we use the ordinary General Public License for many libraries. However, the Lesser license provides

advantages in certain special circumstances.

For example, on rare occasions, there may be a special need to encourage the widest possible use of a certain library, so that it becomes a de-facto standard. To achieve this, non-free programs must be allowed to use the library. A more frequent case is that a free library does the same job as widely used non-free libraries. In this case, there is little to gain by limiting the free library to free software only, so we use the Lesser General Public License.

In other cases, permission to use a particular library in non-free programs enables a greater number of people to use a large body of free software. For example, permission to use the GNU C Library in non-free programs enables many more people to use the whole GNU operating system, as well as its variant, the GNU/Linux operating system.

Although the Lesser General Public License is Less protective of the users' freedom, it does ensure that the user of a program that is linked with the Library has the freedom and the wherewithal to run that program using a modified version of the Library.

The precise terms and conditions for copying, distribution and modification follow. Pay close attention to the difference between a "work based on the library" and a "work that uses the library".

The former contains code derived from the library, whereas the latter must be combined with the library in order to run.

TERMS AND CONDITIONS FOR COPYING, DISTRIBUTION AND MODIFICATION

0. This License Agreement applies to any software library or other program which contains a notice placed by the copyright holder or other authorized party saying it may be distributed under the terms of this Lesser General Public License (also called "this License").

Each licensee is addressed as "you".

A "library" means a collection of software functions and/or data prepared so as to be conveniently linked with application programs (which use some of those functions and data) to form executables.

The "Library", below, refers to any such software library or work which has been distributed under these terms. A "work based on the Library" means either the Library or any derivative work under copyright law: that is to say, a work containing the Library or a portion of it, either verbatim or with modifications and/or translated straightforwardly into another language. (Hereinafter, translation is included without limitation in the term "modification.")

"Source code" for a work means the preferred form of the work for making modifications to it. For a library, complete source code means all the source code for all modules it contains, plus any associated interface definition files, plus the scripts used to control compilation and installation of the library.

Activities other than copying, distribution and modification are not covered by this License; they are outside its scope. The act of running a program using the Library is not restricted, and output from such a program is covered only if its contents constitute a work based on the Library (independent of the use of the Library in a tool for writing it). Whether that is true depends on what the Library does and what the program that uses the Library does.

1. You may copy and distribute verbatim copies of the Library's complete source code as you receive it, in any medium, provided that you conspicuously and appropriately publish on each copy an appropriate copyright notice and disclaimer of warranty; keep intact all the notices that refer to this License and to the absence of any warranty; and distribute a copy of this License along with the Library.

You may charge a fee for the physical act of transferring a copy, and you may at your option offer warranty protection in exchange for a fee.

2. You may modify your copy or copies of the Library or any portion of it, thus forming a work based on the Library, and copy and distribute such modifications or work under the terms of Section 1 above, provided that you also meet all of these conditions:

- a) The modified work must itself be a software library.
- b) You must cause the files modified to carry prominent notices stating that you changed the files and the date of any change.
- c) You must cause the whole of the work to be licensed at no charge to all third parties under the terms of this License.
- d) If a facility in the modified Library refers to a function or a table of data to be supplied by an application program that uses the

facility, other than as an argument passed when the facility is invoked, then you must make a good faith effort to ensure that, in the event an application does not supply such function or table, the facility still operates, and performs whatever part of its purpose remains meaningful.

(For example, a function in a library to compute square roots has a purpose that is entirely well-defined independent of the application. Therefore, Subsection 2d requires that any application-supplied function or table used by this function must be optional: if the application does not supply it, the square root function must still compute square roots.)

These requirements apply to the modified work as a whole. If identifiable sections of that work are not derived from the Library, and can be reasonably considered independent and separate works in themselves, then this License, and its terms, do not apply to those sections when you distribute them as separate works. But when you distribute the same sections as part of a whole which is a work based on the Library, the distribution of the whole must be on the terms of this License, whose permissions for other licensees extend to the entire whole, and thus to each and every part regardless of who wrote it.

Thus, it is not the intent of this section to claim rights or contest your rights to work written entirely by you; rather, the intent is to exercise the right to control the distribution of derivative or collective works based on the Library.

In addition, mere aggregation of another work not based on the Library with the Library (or with a work based on the Library) on a volume of a storage or distribution medium does not bring the other work under the scope of this License.

3. You may opt to apply the terms of the ordinary GNU General Public License instead of this License to a given copy of the Library. To do this, you must alter all the notices that refer to this License, so that they refer to the ordinary GNU General Public License, version 2, instead of to this License. (If a newer version than version 2 of the ordinary GNU General Public License has appeared, then you can specify that version instead if you wish.) Do not make any other change in these notices.

Once this change is made in a given copy, it is irreversible for that copy, so the ordinary GNU General Public License applies to all subsequent copies and derivative works made from that copy.

This option is useful when you wish to copy part of the code of the Library into a program that is not a library.

4. You may copy and distribute the Library (or a portion or derivative of it, under Section 2) in object code or executable form under the terms of Sections 1 and 2 above provided that you accompany it with the complete corresponding machine-readable source code, which must be distributed under the terms of Sections 1 and 2 above on a medium customarily used for software interchange.

If distribution of object code is made by offering access to copy from a designated place, then offering equivalent access to copy the source code from the same place satisfies the requirement to distribute the source code, even though third parties are not compelled to copy the source along with the object code.

5. A program that contains no derivative of any portion of the Library, but is designed to work with the Library by being compiled or linked with it, is called a "work that uses the Library". Such a work, in isolation, is not a derivative work of the Library, and therefore falls outside the scope of this License.

However, linking a "work that uses the Library" with the Library creates an executable that is a derivative of the Library (because it contains portions of the Library), rather than a "work that uses the library". The executable is therefore covered by this License. Section 6 states terms for distribution of such executables.

When a "work that uses the Library" uses material from a header file that is part of the Library, the object code for the work may be a derivative work of the Library even though the source code is not.

Whether this is true is especially significant if the work can be linked without the Library, or if the work is itself a library. The threshold for this to be true is not precisely defined by law.

If such an object file uses only numerical parameters, data structure layouts and accessors, and small macros and small inline functions (ten lines or less in length), then the use of the object file is unrestricted, regardless of whether it is legally a derivative work. (Executables containing this object code plus



portions of the Library will still fall under Section 6.) Otherwise, if the work is a derivative of the Library, you may distribute the object code for the work under the terms of Section 6. Any executables containing that work also fall under Section 6, whether or not they are linked directly with the Library itself.

6. As an exception to the Sections above, you may also combine or link a "work that uses the Library" with the Library to produce a work containing portions of the Library, and distribute that work under terms of your choice, provided that the terms permit modification of the work for the customer's own use and reverse engineering for debugging such modifications. You must give prominent notice with each copy of the work that the Library is used in it and that the Library and its use are covered by this License. You must supply a copy of this License. If the work during execution displays copyright notices, you must include the copyright notice for the Library among them, as well as a reference directing the user to the copy of this License. Also, you must do one of these things:
 - a) Accompany the work with the complete corresponding machine-readable source code for the Library including whatever changes were used in the work (which must be distributed under Sections 1 and 2 above); and, if the work is an executable linked with the Library, with the complete machine-readable "work that uses the Library," as object code and/or source code, so that the user can modify the Library and then relink to produce a modified executable containing the modified Library. (It is understood that the user who changes the contents of definitions files in the Library will not necessarily be able to recompile the application to use the modified definitions.)
 - b) Use a suitable shared library mechanism for linking with the Library. A suitable mechanism is one that (1) uses at run time a copy of the library already present on the user's computer system, rather than copying library functions into the executable, and (2) will operate properly with a modified version of the library, if the user installs one, as long as the modified version is interface-compatible with the version that the work was made with.
 - c) Accompany the work with a written offer, valid for at least three years, to give the same user the materials specified in Subsection 6a, above, for a charge no more than the cost of performing this distribution.
 - d) If distribution of the work is made by offering access to copy from a designated place, offer equivalent access to copy the above specified materials from the same place.
 - e) Verify that the user has already received a copy of these materials or that you have already sent this user a copy.
- For an executable, the required form of the "work that uses the Library" must include any data and utility programs needed for reproducing the executable from it. However, as a special exception, the materials to be distributed need not include anything that is normally distributed (in either source or binary form) with the major components (compiler, kernel, and so on) of the operating system on which the executable runs, unless that component itself accompanies the executable. It may happen that this requirement contradicts the license restrictions of other proprietary libraries that do not normally accompany the operating system. Such a contradiction means you cannot use both them and the Library together in an executable that you distribute.
7. You may place library facilities that are a work based on the Library side-by-side in a single library together with other library facilities not covered by this License, and distribute such a combined library, provided that the separate distribution of the work based on the Library and of the other library facilities is otherwise permitted, and provided that you do these two things:
 - a) Accompany the combined library with a copy of the same work based on the Library, uncombined with any other library facilities. This must be distributed under the terms of the Sections above.
 - b) Give prominent notice with the combined library of the fact that part of it is a work based on the Library, and explaining where to find the accompanying uncombined form of the same work.
 8. You may not copy, modify, sublicense, link with, or distribute

the Library except as expressly provided under this License. Any attempt otherwise to copy, modify, sublicense, link with, or distribute the Library is void, and will automatically terminate your rights under this License. However, parties who have received copies, or rights, from you under this License will not have their licenses terminated so long as such parties remain in full compliance.

9. You are not required to accept this License, since you have not signed it. However, nothing else grants you permission to modify or distribute the Library or its derivative works. These actions are prohibited by law if you do not accept this License. Therefore, by modifying or distributing the Library (or any work based on the Library), you indicate your acceptance of this License to do so, and all its terms and conditions for copying, distributing or modifying the Library or works based on it.
10. Each time you redistribute the Library (or any work based on the Library), the recipient automatically receives a license from the original licensor to copy, distribute, link with or modify the Library subject to these terms and conditions. You may not impose any further restrictions on the recipients' exercise of the rights granted herein. You are not responsible for enforcing compliance by third parties with this License.
11. If, as a consequence of a court judgment or allegation of patent infringement or for any other reason (not limited to patent issues), conditions are imposed on you (whether by court order, agreement or otherwise) that contradict the conditions of this License, they do not excuse you from the conditions of this License. If you cannot distribute so as to satisfy simultaneously your obligations under this License and any other pertinent obligations, then as a consequence you may not distribute the Library at all. For example, if a patent license would not permit royalty-free redistribution of the Library by all those who receive copies directly or indirectly through you, then the only way you could satisfy both it and this License would be to refrain entirely from distribution of the Library. If any portion of this section is held invalid or unenforceable under any particular circumstance, the balance of the section is intended to apply, and the section as a whole is intended to apply in other circumstances. It is not the purpose of this section to induce you to infringe any patents or other property right claims or to contest validity of any such claims; this section has the sole purpose of protecting the integrity of the free software distribution system which is implemented by public license practices. Many people have made generous contributions to the wide range of software distributed through that system in reliance on consistent application of that system; it is up to the author/donor to decide if he or she is willing to distribute software through any other system and a licensee cannot impose that choice. This section is intended to make thoroughly clear what is believed to be a consequence of the rest of this License.
12. If the distribution and/or use of the Library is restricted in certain countries either by patents or by copyrighted interfaces, the original copyright holder who places the Library under this License may add an explicit geographical distribution limitation excluding those countries, so that distribution is permitted only in or among countries not thus excluded. In such case, this License incorporates the limitation as if written in the body of this License.
13. The Free Software Foundation may publish revised and/or new versions of the Lesser General Public License from time to time. Such new versions will be similar in spirit to the present version, but may differ in detail to address new problems or concerns. Each version is given a distinguishing version number. If the Library specifies a version number of this License which applies to it and "any later version," you have the option of following the terms and conditions either of that version or of any later version published by the Free Software Foundation. If the Library does not specify a license version number, you may choose any version ever published by the Free Software Foundation.
14. If you wish to incorporate parts of the Library into other free programs whose distribution conditions are incompatible with these, write to the author to ask for permission. For software which is copyrighted by the Free Software Foundation, write to the Free Software Foundation; we sometimes make exceptions for this. Our decision will be guided by the two goals of

preserving the free status of all derivatives of our free software and of promoting the sharing and reuse of software generally.

NO WARRANTY

15. BECAUSE THE LIBRARY IS LICENSED FREE OF CHARGE, THERE IS NO WARRANTY FOR THE LIBRARY, TO THE EXTENT PERMITTED BY APPLICABLE LAW. EXCEPT WHEN OTHERWISE STATED IN WRITING THE COPYRIGHT HOLDERS AND/OR OTHER PARTIES PROVIDE THE LIBRARY "AS IS" WITHOUT WARRANTY OF ANY KIND, EITHER EXPRESSED OR IMPLIED, INCLUDING, BUT NOT LIMITED TO, THE IMPLIED WARRANTIES OF MERCHANTABILITY AND FITNESS FOR A PARTICULAR PURPOSE. THE ENTIRE RISK AS TO THE QUALITY AND PERFORMANCE OF THE LIBRARY IS WITH YOU. SHOULD THE LIBRARY PROVE DEFECTIVE, YOU ASSUME THE COST OF ALL NECESSARY SERVICING, REPAIR OR CORRECTION.
16. IN NO EVENT UNLESS REQUIRED BY APPLICABLE LAW OR AGREED TO IN WRITING WILL ANY COPYRIGHT HOLDER, OR ANY OTHER PARTY WHO MAY MODIFY AND/OR REDISTRIBUTE THE LIBRARY AS PERMITTED ABOVE, BE LIABLE TO YOU FOR DAMAGES, INCLUDING ANY GENERAL, SPECIAL, INCIDENTAL OR CONSEQUENTIAL DAMAGES ARISING OUT OF THE USE OR INABILITY TO USE THE LIBRARY (INCLUDING BUT NOT LIMITED TO LOSS OF DATA OR DATA BEING RENDERED INACCURATE OR LOSSES SUSTAINED BY YOU OR THIRD PARTIES OR A FAILURE OF THE LIBRARY TO OPERATE WITH ANY OTHER SOFTWARE), EVEN IF SUCH HOLDER OR OTHER PARTY HAS BEEN ADVISED OF THE POSSIBILITY OF SUCH DAMAGES.

END OF TERMS AND CONDITIONS

How to Apply These Terms to Your New Libraries

If you develop a new library, and you want it to be of the greatest possible use to the public, we recommend making it free software that everyone can redistribute and change. You can do so by permitting redistribution under these terms (or, alternatively, under the terms of the ordinary General Public License).

To apply these terms, attach the following notices to the library. It is safest to attach them to the start of each source file to most effectively convey the exclusion of warranty; and each file should have at least the "copyright" line and a pointer to where the full notice is found.

<one line to give the library's name and a brief idea of what it does.>

Copyright (C) <year> <name of author>

This library is free software; you can redistribute it and/or modify it under the terms of the GNU Lesser General Public License as published by the Free Software Foundation; either version 2.1 of the License, or (at your option) any later version.

This library is distributed in the hope that it will be useful, but WITHOUT ANY WARRANTY; without even the implied warranty of MERCHANTABILITY or FITNESS FOR A PARTICULAR PURPOSE. See the GNU Lesser General Public License for more details.

You should have received a copy of the GNU Lesser General Public License along with this library; if not, write to the Free Software Foundation, Inc., 59 Temple Place, Suite 330, Boston, MA 02111-1307 USA

Also add information on how to contact you by electronic and paper mail.

You should also get your employer (if you work as a programmer) or your school, if any, to sign a "copyright disclaimer" for the library, if necessary. Here is a sample; alter the names:

Yoyodyne, Inc., hereby disclaims all copyright interest in the library 'Frob' (a library for tweaking knobs) written by James Random Hacker.

<signature of Ty Coon>, 1 April 1990

Ty Coon, President of Vice

That's all there is to it!

Exhibit-C

Copyright notice:
(C) 1995-2004 Jean-loup Gailly and Mark Adler

This software is provided 'as-is', without any express or implied warranty. In no event will the authors be held liable for any damages arising from the use of this software. Permission is granted to anyone to use this software for any purpose, including commercial applications, and to alter it and redistribute it

freely, subject to the following restrictions:

1. The origin of this software must not be misrepresented; you must not claim that you wrote the original software. If you use this software in a product, an acknowledgment in the product documentation would be appreciated but is not required.
2. Altered source versions must be plainly marked as such, and must not be misrepresented as being the original software.
3. This notice may not be removed or altered from any source distribution.
Jean-loup Gailly Mark Adler
jloup@gzip.org madler@alumni.caltech.edu

If you use the zlib library in a product, we would appreciate *not* receiving lengthy legal documents to sign. The sources are provided for free but without warranty of any kind. The library has been entirely written by Jean-loup Gailly and Mark Adler; it does not include third-party code.

If you redistribute modified sources, we would appreciate that you include in the file ChangeLog history information documenting your changes. Please read the FAQ for more information on the distribution of modified source versions.

Exhibit-D

Copyright (c) 1998, 1999, 2000 Thai Open Source Software Center Ltd and Clark Cooper
Copyright (c) 2001, 2002 Expat maintainers.

Permission is hereby granted, free of charge, to any person obtaining a copy of this software and associated documentation files (the "Software"), to deal in the Software without restriction, including without limitation the rights to use, copy, modify, merge, publish, distribute, sublicense, and/or sell copies of the Software, and to permit persons to whom the Software is furnished to do so, subject to the following conditions:

The above copyright notice and this permission notice shall be included in all copies or substantial portions of the Software.

THE SOFTWARE IS PROVIDED "AS IS" WITHOUT WARRANTY OF ANY KIND, EXPRESS OR IMPLIED, INCLUDING BUT NOT LIMITED TO THE WARRANTIES OF MERCHANTABILITY, FITNESS FOR A PARTICULAR PURPOSE AND NONINFRINGEMENT.

IN NO EVENT SHALL THE AUTHORS OR COPYRIGHT HOLDERS BE LIABLE FOR ANY CLAIM, DAMAGES OR OTHER LIABILITY, WHETHER IN AN ACTION OF CONTRACT, TORT OR OTHERWISE, ARISING FROM, OUT OF OR IN CONNECTION WITH THE SOFTWARE OR THE USE OR OTHER DEALINGS IN THE SOFTWARE.

Exhibit-E

The Independent JPEG Group's JPEG software
README for release 6b of 27-Mar-1998

This distribution contains the sixth public release of the Independent JPEG Group's free JPEG software. You are welcome to redistribute this software and to use it for any purpose, subject to the conditions under LEGAL ISSUES, below.

Serious users of this software (particularly those incorporating it into larger programs) should contact IJG at jpeg-info@uunet.uu.net to be added to our electronic mailing list. Mailing list members are notified of updates and have a chance to participate in technical discussions, etc.

This software is the work of Tom Lane, Philip Gladstone, Jim Boucher, Lee Crocker, Julian Minguillon, Luis Ortiz, George Phillips, Davide Rossi, Guido Vollbeding, Ge' Weijers, and other members of the Independent JPEG Group.

IJG is not affiliated with the official ISO JPEG standards committee. DOCUMENTATION ROADMAP

This file contains the following sections:

OVERVIEW	General description of JPEG and the IJG software.
LEGAL ISSUES	Copyright, lack of warranty, terms of distribution.
REFERENCES	Where to learn more about JPEG.
ARCHIVE LOCATIONS	Where to find newer versions of this software.
RELATED SOFTWARE	Other stuff you should get.
FILE FORMAT WARS	Software "not" to get.
TO DO	Plans for future IJG releases.

Other documentation files in the distribution are:

User documentation:

install.doc	How to configure and install the IJG software.
usage.doc	Usage instructions for cjpeg, djpeg, jpegtran, rdjpgcom, and wrjpgcom.
*.1	Unix-style man pages for programs (same info as usage.doc).
wizard.doc	Advanced usage instructions for JPEG wizards only.
change.log	Version-to-version change highlights.
Programmer and internal documentation:	
libjpeg.doc	How to use the JPEG library in your own programs.
example.c	Sample code for calling the JPEG library.
structure.doc	Overview of the JPEG library's internal structure.
filelist.doc	Road map of IJG files.
coderrules.doc	Coding style rules — please read if you contribute code.

Please read at least the files install.doc and usage.doc. Useful information can also be found in the JPEG FAQ (Frequently Asked Questions) article. See ARCHIVE LOCATIONS below to find out where to obtain the FAQ article.

If you want to understand how the JPEG code works, we suggest reading one or more of the REFERENCES, then looking at the documentation files (in roughly the order listed) before diving into the code.

OVERVIEW

This package contains C software to implement JPEG image compression and decompression. JPEG (pronounced "jay-peg") is a standardized compression method for full-color and gray-scale images. JPEG is intended for compressing "real-world" scenes; line drawings, cartoons and other non-realistic images are not its strong suit. JPEG is lossy, meaning that the output image is not exactly identical to the input image. Hence you must not use JPEG if you have to have identical output bits. However, on typical photographic images, very good compression levels can be obtained with no visible change, and remarkably high compression levels are possible if you can tolerate a low-quality image. For more details, see the references, or just experiment with various compression settings.

This software implements JPEG baseline, extended-sequential, and progressive compression processes. Provision is made for supporting all variants of these processes, although some uncommon parameter settings aren't implemented yet.

For legal reasons, we are not distributing code for the arithmetic-coding

variants of JPEG; see LEGAL ISSUES. We have made no provision for supporting the hierarchical or lossless processes defined in the standard. We provide a set of library routines for reading and writing JPEG image files, plus two sample applications "cjpeg" and "djpeg" which use the library to perform conversion between JPEG and some other popular image file formats.

The library is intended to be reused in other applications.

In order to support file conversion and viewing software, we have included considerable functionality beyond the bare JPEG coding/decoding capability; for example, the color quantization modules are not strictly part of JPEG decoding, but they are essential for output to colormapped file formats or colormapped displays. These extra functions can be compiled out of the library if not required for a particular application. We have also included "jpegtran", a utility for lossless transcoding between different JPEG processes, and "rdjpgcom" and "wrjpgcom", two simple applications for inserting and extracting textual comments in JFIF files.

The emphasis in designing this software has been on achieving portability and flexibility, while also making it fast enough to be useful. In particular, the software is not intended to be read as a tutorial on JPEG. (See the REFERENCES section for introductory material.) Rather, it is intended to be reliable, portable, industrial-strength code. We do not claim to have achieved that goal in every aspect of the software, but we strive for it.

We welcome the use of this software as a component of commercial

products.

No royalty is required, but we do ask for an acknowledgement in product documentation, as described under LEGAL ISSUES.

LEGAL ISSUES

In plain English:

1. We don't promise that this software works. (But if you find any bugs, please let us know!)
2. You can use this software for whatever you want. You don't have to pay us.
3. You may not pretend that you wrote this software. If you use it in a program, you must acknowledge somewhere in your documentation that you've used the IJG code.

In legalese:

The authors make NO WARRANTY or representation, either express or implied, with respect to this software, its quality, accuracy, merchantability, or fitness for a particular purpose. This software is provided "AS IS," and you, its user, assume the entire risk as to its quality and accuracy.

This software is copyright (C) 1991-1998, Thomas G. Lane.

All Rights Reserved except as specified below.

Permission is hereby granted to use, copy, modify, and distribute this software (or portions thereof) for any purpose, without fee, subject to these conditions:

- (1) If any part of the source code for this software is distributed, then this README file must be included, with this copyright and no-warranty notice unaltered; and any additions, deletions, or changes to the original files must be clearly indicated in accompanying documentation.
- (2) If only executable code is distributed, then the accompanying documentation must state that "this software is based in part on the work of the Independent JPEG Group."
- (3) Permission for use of this software is granted only if the user accepts full responsibility for any undesirable consequences; the authors accept NO LIABILITY for damages of any kind.

These conditions apply to any software derived from or based on the IJG code, not just to the unmodified library. If you use our work, you ought to acknowledge us.

Permission is NOT granted for the use of any IJG author's name or company name in advertising or publicity relating to this software or products derived from it. This software may be referred to only as "the Independent JPEG Group's software".

We specifically permit and encourage the use of this software as the basis of commercial products, provided that all warranty or liability claims are assumed by the product vendor.

ansi2knr.c is included in this distribution by permission of L. Peter Deutsch, sole proprietor of its copyright holder, Aladdin Enterprises of Menlo Park, CA.

ansi2knr.c is NOT covered by the above copyright and conditions, but instead by the usual distribution terms of the Free Software Foundation; principally, that you must include source code if you redistribute it. (See the file ansi2knr.c for full details.) However, since ansi2knr.c is not needed as part of any program generated from the IJG code, this does not limit you more than the foregoing paragraphs do.

The Unix configuration script "configure" was produced with GNU Autoconf.

It is copyright by the Free Software Foundation but is freely distributable.

The same holds for its supporting scripts (config.guess, config.sub, ltconfig, ltmain.sh). Another support script, install-sh, is copyright by M.I.T. but is also freely distributable.

It appears that the arithmetic coding option of the JPEG spec is covered by patents owned by IBM, AT&T, and Mitsubishi. Hence arithmetic coding cannot legally be used without obtaining one or more licenses. For this reason, support for arithmetic coding has been removed from the free JPEG software.

(Since arithmetic coding provides only a marginal gain over the unpatented Huffman mode, it is unlikely that very many implementations will support it.)

So far as we are aware, there are no patent restrictions on the remaining code.

The IJG distribution formerly included code to read and write GIF files.

To avoid entanglement with the Unisys LZW patent, GIF reading support has been removed altogether, and the GIF writer has been

simplified to produce "uncompressed GIFs". This technique does not use the LZW algorithm; the resulting GIF files are larger than usual, but are readable by all standard GIF decoders.

We are required to state that

"The Graphics Interchange Format(c) is the Copyright property of CompuServe Incorporated. GIF(sm) is a Service Mark property of CompuServe Incorporated."

REFERENCES

We highly recommend reading one or more of these references before trying to understand the innards of the JPEG software.

The best short technical introduction to the JPEG compression algorithm is

Wallace, Gregory K. "The JPEG Still Picture Compression Standard", Communications of the ACM, April 1991 (vol. 34 no. 4), pp. 30-44.

(Adjacent articles in that issue discuss MPEG motion picture compression, applications of JPEG, and related topics.) If you don't have the CACM issue handy, a PostScript file containing a revised version of Wallace's article is available at <ftp://ftp.uu.net/graphics/jpeg/wallace.ps.gz>. The file (actually a preprint for an article that appeared in IEEE Trans. Consumer Electronics) omits the sample images that appeared in CACM, but it includes corrections and some added material. Note: the Wallace article is copyright ACM and IEEE, and it may not be used for commercial purposes.

A somewhat less technical, more leisurely introduction to JPEG can be found in "The Data Compression Book" by Mark Nelson and Jean-loup Gailly, published by M&T Books (New York), 2nd ed. 1996, ISBN 1-55851-434-1. This book provides good explanations and example C code for a multitude of compression methods including JPEG. It is an excellent source if you are comfortable reading C code but don't know much about data compression in general. The book's JPEG sample code is far from industrial-strength, but when you are ready to look at a full implementation, you've got one here...

The best full description of JPEG is the textbook "JPEG Still Image Data Compression Standard" by William B. Pennebaker and Joan L. Mitchell, published by Van Nostrand Reinhold, 1993, ISBN 0-442-01272-1. Price US\$59.95, 638 pp.

The book includes the complete text of the ISO JPEG standards (DIS 10918-1 and draft DIS 10918-2).

This is by far the most complete exposition of JPEG in existence, and we highly recommend it.

The JPEG standard itself is not available electronically; you must order a paper copy through ISO or ITU. (Unless you feel a need to own a certified official copy, we recommend buying the Pennebaker and Mitchell book instead; it's much cheaper and includes a great deal of useful explanatory material.)

In the USA, copies of the standard may be ordered from ANSI Sales at (212) 642-4900, or from Global Engineering Documents at (800) 854-7179. (ANSI doesn't take credit card orders, but Global does.) It's not cheap: as of 1992, ANSI was charging \$95 for Part 1 and \$47 for Part 2, plus 7% shipping/handling. The standard is divided into two parts, Part 1 being the actual specification, while Part 2 covers compliance testing methods. Part 1 is titled "Digital Compression and Coding of Continuous-tone Still Images, Part 1: Requirements and guidelines" and has document numbers ISO/IEC IS 10918-1, ITU-T T.81. Part 2 is titled "Digital Compression and Coding of Continuous-tone Still Images, Part 2: Compliance testing" and has document numbers ISO/IEC IS 10918-2, ITU-T T.83.

Some extensions to the original JPEG standard are defined in JPEG Part 3, a newer ISO standard numbered ISO/IEC IS 10918-3 and ITU-T T.84. IJG currently does not support any Part 3 extensions. The JPEG standard does not specify all details of an interchangeable file format. For the omitted details we follow the "JFIF" conventions, revision 1.02. A copy of the JFIF spec is available from:

Literature Department
C-Cube Microsystems, Inc.
1778 McCarthy Blvd.
Milpitas, CA 95035
phone (408) 944-6300, fax (408) 944-6314

A PostScript version of this document is available by FTP at <ftp://ftp.uu.net/graphics/jpeg/jfif.ps.gz>. There is also a plain text version at <ftp://ftp.uu.net/graphics/peg/jfif.txt.gz>, but it is missing the figures.

The TIFF 6.0 file format specification can be obtained by FTP from <ftp://ftp.sgi.com/graphics/tiff/TIFF6.ps.gz>. The JPEG incorporation scheme found in the TIFF 6.0 spec of 3-June-92 has a number of serious problems.

IJG does not recommend use of the TIFF 6.0 design (TIFF Compression tag 6).

Instead, we recommend the JPEG design proposed by TIFF Technical Note #2 (Compression tag 7). Copies of this Note can be obtained from <ftp.sgi.com> or from <ftp://ftp.uu.net/graphics/jpeg/>. It is expected that the next revision of the TIFF spec will replace the 6.0 JPEG design with the Note's design.

Although IJG's own code does not support TIFF/JPEG, the free libtiff library uses our library to implement TIFF/JPEG per the Note. libtiff is available from <ftp://ftp.sgi.com/graphics/tiff/>.

ARCHIVE LOCATIONS

The "official" archive site for this software is <ftp.uu.net> (Internet address 192.48.96.9). The most recent released version can always be found there in directory <graphics/jpeg>. This particular version will be archived as <ftp://ftp.uu.net/graphics/jpeg/jpegsrc.v6b.tar.gz>.

If you don't have direct Internet access, UUNET's archives are also available via UUCP; contact help@uunet.uu.net for information on retrieving files that way.

Numerous Internet sites maintain copies of the UUNET files. However, only <ftp.uu.net> is guaranteed to have the latest official version.

You can also obtain this software in DOS-compatible "zip" archive format from the SimTel archives (<ftp://ftp.simtel.net/pub/simtelnet/msdos/graphics/>), or on CompuServe in the Graphics Support forum (GO CIS:GRAPHSUP), library 12 "JPEG Tools". Again, these versions may sometimes lag behind the <ftp.uu.net> release.

The JPEG FAQ (Frequently Asked Questions) article is a useful source of general information about JPEG. It is updated constantly and therefore is not included in this distribution. The FAQ is posted every two weeks to Usenet newsgroups <comp.graphics.misc>, <news.answers>, and other groups.

It is available on the World Wide Web at <http://www.faqs.org/faqs/jpeg-faq/> and other news.answers archive sites, including the official news.answers archive at <rtfm.mit.edu>: <ftp://rtfm.mit.edu/pub/usenet/news.answers/jpeg-faq/>.

If you don't have Web or FTP access, send e-mail to mail-server@rtfm.mit.edu with body

```
send usenet/news.answers/jpeg-faq/part1
send usenet/news.answers/jpeg-faq/part2
```

RELATED SOFTWARE

Numerous viewing and image manipulation programs now support JPEG. (Quite a few of them use this library to do so.) The JPEG FAQ described above lists some of the more popular free and shareware viewers, and tells where to obtain them on Internet.

If you are on a Unix machine, we highly recommend Jef Poskanzer's free PBMPPLUS software, which provides many useful operations on PPM-format image files. In particular, it can convert PPM images to and from a wide range of other formats, thus making cjpeg/djpeg considerably more useful. The latest version is distributed by the NetPBM group, and is available from numerous sites, notably <ftp://wuarhive.wustl.edu/graphics/graphics/packages/NetPBM/>.

Unfortunately PBMPPLUS/NETPBM is not nearly as portable as the IJG software is; you are likely to have difficulty making it work on any non-Unix machine.

A different free JPEG implementation, written by the PVRG group at Stanford,

is available from <ftp://havefun.stanford.edu/pub/jpeg/>. This program is designed for research and experimentation rather than production use; it is slower, harder to use, and less portable than the IJG code, but it is easier to read and modify. Also, the PVRG code supports lossless JPEG, which we do not. (On the other hand, it doesn't do progressive JPEG.)

FILE FORMAT WARS

Some JPEG programs produce files that are not compatible with our library.

The root of the problem is that the ISO JPEG committee failed to specify a concrete file format. Some vendors "filled in the blanks" on their own, creating proprietary formats that no one else could read. (For example, none of the early commercial JPEG implementations for the Macintosh were able to exchange compressed files.)

The file format we have adopted is called JFIF (see REFERENCES). This format has been agreed to by a number of major commercial JPEG vendors, and it has become the de facto standard. JFIF is a minimal or "low end" representation.

We recommend the use of TIFF/JPEG (TIFF revision 6.0 as modified



by TIFF Technical Note #2) for “high end” applications that need to record a lot of additional data about an image. TIFF/JPEG is fairly new and not yet widely supported, unfortunately. The upcoming JPEG Part 3 standard defines a file format called SPIFF.

SPIFF is interoperable with JFIF, in the sense that most JFIF decoders should be able to read the most common variant of SPIFF. SPIFF has some technical advantages over JFIF, but its major claim to fame is simply that it is an official standard rather than an informal one. At this point it is unclear whether SPIFF will supersede JFIF or whether JFIF will remain the de-facto standard. IJG intends to support SPIFF once the standard is frozen, but we have not decided whether it should become our default output format or not.

(In any case, our decoder will remain capable of reading JFIF indefinitely.)

Various proprietary file formats incorporating JPEG compression also exist.

We have little or no sympathy for the existence of these formats. Indeed, one of the original reasons for developing this free software was to help force convergence on common, open format standards for JPEG files. Don't use a proprietary file format!

TO DO

The major thrust for v7 will probably be improvement of visual quality.

The current method for scaling the quantization tables is known not to be very good at low Q values. We also intend to investigate block boundary smoothing, “poor man's variable quantization”, and other means of improving quality-vs-file-size performance without sacrificing compatibility.

In future versions, we are considering supporting some of the upcoming JPEG Part 3 extensions — principally, variable quantization and the SPIFF file format.

As always, speeding things up is of great interest.

Please send bug reports, offers of help, etc. to jpeg-info@uunet.uu.net.

❑ Exhibit-F

COPYRIGHT NOTICE, DISCLAIMER, and LICENSE:

If you modify libpng you may insert additional notices immediately following this sentence.

libpng version 1.2.6, August 15, 2004, is Copyright (c) 2004 Glenn Randers-Pehrson, and is distributed according to the same disclaimer and license as libpng-1.2.5 with the following individual added to the list of Contributing Authors

Cosmin Truta

libpng versions 1.0.7, July 1, 2000, through 1.2.5 - October 3, 2002, are Copyright (c) 2000-2002 Glenn Randers-Pehrson, and are distributed according to the same disclaimer and license as libpng-1.0.6 with the following individuals added to the list of Contributing Authors

Simon-Pierre Cadieux

Eric S. Raymond

Gilles Vollant

and with the following additions to the disclaimer:

There is no warranty against interference with your enjoyment of the library or against infringement. There is no warranty that our efforts or the library will fulfill any of your particular purposes or needs. This library is provided with all faults, and the entire risk of satisfactory quality, performance, accuracy, and effort is with the user.

libpng versions 0.97, January 1998, through 1.0.6, March 20, 2000, are Copyright (c) 1998, 1999 Glenn Randers-Pehrson, and are distributed according to the same disclaimer and license as libpng-0.96, with the following individuals added to the list of Contributing Authors:

Tom Lane

Glenn Randers-Pehrson

Willem van Schaik

libpng versions 0.89, June 1996, through 0.96, May 1997, are Copyright (c) 1996, 1997 Andreas Dilger Contributed according to the same disclaimer and license as libpng-0.88, with the following individuals added to the list of Contributing Authors:

John Bowler

Kevin Bracey

Sam Bushell

Magnus Holmgren

Greg Roelofs

Tom Tanner

libpng versions 0.5, May 1995, through 0.88, January 1996, are Copyright (c) 1995, 1996 Guy Eric Schalnat, Group 42, Inc.

For the purposes of this copyright and license, “Contributing Authors” is defined as the following set of individuals:

Andreas Dilger

Dave Martindale

Guy Eric Schalnat

Paul Schmidt

Tim Wegner

The PNG Reference Library is supplied “AS IS.” The Contributing Authors and Group 42, Inc. disclaim all warranties, expressed or implied, including, without limitation, the warranties of merchantability and of fitness for any purpose. The Contributing Authors and Group 42, Inc. assume no liability for direct, indirect, incidental, special, exemplary, or consequential damages, which may result from the use of the PNG Reference Library, even if advised of the possibility of such damage.

Permission is hereby granted to use, copy, modify, and distribute this source code, or portions hereof, for any purpose, without fee, subject to the following restrictions:

1. The origin of this source code must not be misrepresented.
2. Altered versions must be plainly marked as such and must not be misrepresented as being the original source.
3. This Copyright notice may not be removed or altered from any source or altered source distribution.

The Contributing Authors and Group 42, Inc. specifically permit, without fee, and encourage the use of this source code as a component to supporting the PNG file format in commercial products. If you use this source code in a product, acknowledgment is not required but would be appreciated.

A “png_get_copyright” function is available, for convenient use in “about” boxes and the like: `printf(“%s”,png_get_copyright(NULL));`

Also, the PNG logo (in PNG format, of course) is supplied in the files “pngbar.png” and “pngbar.jpg (88x31)” and “pngnow.png” (98x31).

Libpng is OSI Certified Open Source Software. OSI Certified Open Source is a certification mark of the Open Source Initiative.

Glenn Randers-Pehrson

glenrnp@users.sourceforge.net

August 15, 2004

❑ Exhibit-G

Copyright (c) 2001,2003 Keith Packard

Permission to use, copy, modify, distribute, and sell this software and its documentation for any purpose is hereby granted without fee, provided that the above copyright notice appear in all copies and that both that copyright notice and this permission notice appear in supporting documentation, and that the name of Keith Packard not be used in advertising or publicity pertaining to distribution of the software without specific, written prior permission. Keith Packard makes no representations about the suitability of this software for any purpose. It is provided “as is” without express or implied warranty.

KEITH PACKARD DISCLAIMS ALL WARRANTIES WITH REGARD TO THIS SOFTWARE, INCLUDING ALL IMPLIED WARRANTIES OF MERCHANTABILITY AND FITNESS, IN NO EVENT SHALL KEITH PACKARD BE LIABLE FOR ANY SPECIAL, INDIRECT OR CONSEQUENTIAL DAMAGES OR ANY DAMAGES WHATSOEVER RESULTING FROM LOSS OF USE, DATA OR PROFITS, WHETHER IN AN ACTION OF CONTRACT, NEGLIGENCE OR OTHER TORTIOUS ACTION, ARISING OUT OF OR IN CONNECTION WITH THE USE OR PERFORMANCE OF THIS SOFTWARE.

❑ Exhibit-H

The FreeType Project LICENSE

2002-Apr-11 Copyright 1996-2002 by David Turner, Robert Wilhelm, and Werner Lemberg

Introduction

The FreeType Project is distributed in several archive packages; some of them may contain, in addition to the FreeType font engine, various tools and contributions which rely on, or relate to, the FreeType Project.

This license applies to all files found in such packages, and which do not fall under their own explicit license. The license affects thus the FreeType font engine, the test programs, documentation and makefiles, at the very least.

This license was inspired by the BSD, Artistic, and IJG (Independent JPEG Group) licenses, which all encourage inclusion and use of free software in commercial and freeware products alike. As a consequence, its main points are that:

- We don't promise that this software works. However, we will be interested in any kind of bug reports. (as is' distribution)
- You can use this software for whatever you want, in parts or full form, without having to pay us. ('royalty-free' usage)
- You may not pretend that you wrote this software. If you use it, or only parts of it, in a program, you must acknowledge somewhere in your documentation that you have used the FreeType code. ('credits')

We specifically permit and encourage the inclusion of this software, with or without modifications, in commercial products.

We disclaim all warranties covering The FreeType Project and assume no liability related to The FreeType Project.

Finally, many people asked us for a preferred form for a credit/disclaimer to use in compliance with this license. We thus encourage you to use the following text:

Portions of this software are copyright © 1996-2002 The FreeType Project (www.freetype.org). All rights reserved.

Legal Terms

0. Definitions

Throughout this license, the terms ‘package’, ‘FreeType Project’, and ‘FreeType archive’ refer to the set of files originally distributed by the authors (David Turner, Robert Wilhelm, and Werner Lemberg) as the ‘FreeType Project’, be they named as alpha, beta or final release.

‘You’ refers to the licensee, or person using the project, where ‘using’ is a generic term including compiling the project's source code as well as linking it to form a ‘program’ or ‘executable’.

This program is referred to as ‘a program using the FreeType engine’.

This license applies to all files distributed in the original FreeType Project, including all source code, binaries and documentation, unless otherwise stated in the file in its original, unmodified form a distributed in the original archive.

If you are unsure whether or not a particular file is covered by this license, you must contact us to verify this.

The FreeType Project is copyright (C) 1996-2000 by David Turner, Robert Wilhelm, and Werner Lemberg. All rights reserved except as specified below.

1. No Warranty
THE FREETYPE PROJECT IS PROVIDED ‘AS IS’ WITHOUT WARRANTY OF ANY KIND, EITHER EXPRESS OR IMPLIED, INCLUDING, BUT NOT LIMITED TO, WARRANTIES OF MERCHANTABILITY AND FITNESS FOR A PARTICULAR PURPOSE. IN NO EVENT WILL ANY OF THE AUTHORS OR COPYRIGHT HOLDERS BE LIABLE FOR ANY DAMAGES CAUSED BY THE USE OR THE INABILITY TO USE, OF THE FREETYPE PROJECT.

2. Redistribution

This license grants a worldwide, royalty-free, perpetual and irrevocable right and license to use, execute, perform, compile, display, copy, create derivative works of, distribute and sublicense the FreeType Project (in both source and object code forms) and derivative works thereof for any purpose; and to authorize others to exercise some or all of the rights granted herein, subject to the following conditions:

- Redistribution of source code must retain this license file (‘FTL.TXT’) unaltered; any additions, deletions or changes to the original files must be clearly indicated in accompanying documentation. The copyright notices of the unaltered, original files must be preserved in all copies of source files.
- Redistribution in binary form must provide a disclaimer that states that the software is based in part of the work of the FreeType Team, in the distribution documentation. We also encourage you to put an URL to the FreeType web page in your documentation, though this isn't mandatory.

These conditions apply to any software derived from or based on the FreeType Project, not just the unmodified files. If you use our work, you must acknowledge us. However, no fee need be paid to us.

3. Advertising

Neither the FreeType authors and contributors nor you shall use the name of the other for commercial, advertising, or promotional purposes without specific prior written permission.

We suggest, but do not require, that you use one or more of the following phrases to refer to this software in your documentation or advertising materials: ‘FreeType Project’, ‘FreeType Engine’, ‘FreeType library’, or ‘FreeType Distribution’.

As you have not signed this license, you are not required to accept it. However, as the FreeType Project is copyrighted material, only this license, or another one contracted with the authors, grants you the right to use, distribute, and modify it.

Therefore, by using, distributing, or modifying the FreeType Project, you indicate that you understand and accept all the terms of this license.

4. Contacts

There are two mailing lists related to FreeType:

- freetype@freetype.org
Discusses general use and applications of FreeType, as well as future and wanted additions to the library and distribution. If you are looking for support, start in this list if you haven't found anything to help you in the documentation.
 - devel@freetype.org
Discusses bugs, as well as engine internals, design issues, specific licenses, porting, etc.
 - <http://www.freetype.org>
Holds the current FreeType web page, which will allow you to download our latest development version and read online documentation.
- You can also contact us individually at:
David Turner <david.turner@freetype.org>
Robert Wilhelm <robert.wilhelm@freetype.org>
Werner Lemberg <werner.lemberg@freetype.org>

❑ Exhibit-I

- * This document is freely plagiarised from the ‘Artistic Licence’, distributed as part of the Perl v4.0 kit by Larry Wall, which is available from most major archive sites

This documents purpose is to state the conditions under which these Packages (See definition below) viz: “Crack”; the Unix Password Cracker, and “CrackLib”, the Unix Password Checking library, which are held in copyright by Alec David Edward Muffett, may be copied, such that the copyright holder maintains some semblance of artistic control over the development of the packages, while giving the users of the package the right to use and distribute the Package in a more-or-less customary fashion, plus the right to make reasonable modifications.

So there.

Definitions:

A “Package” refers to the collection of files distributed by the Copyright Holder, and derivatives of that collection of files created through textual modification, or segments thereof.

“Standard Version” refers to such a Package if it has not been modified, or has been modified in accordance with the wishes of the Copyright Holder.

“Copyright Holder” is whoever is named in the copyright or copyrights for the package.

“You” is you, if you're thinking about copying or distributing this Package.

“Reasonable copying fee” is whatever you can justify on the basis of media cost, duplication charges, time of people involved, and so on. (You will not be required to justify it to the Copyright Holder, but only to the computing community at large as a market that must bear the fee.)

“Freely Available” means that no fee is charged for the item itself, though there may be fees involved in handling the item. It also means that recipients of the item may redistribute it under the same conditions they received it.

1. You may make and give away verbatim copies of the source form of the Standard Version of this Package without restriction, provided that you duplicate all of the original copyright notices and associated disclaimers.
2. You may apply bug fixes, portability fixes and other modifications derived from the Public Domain or from the Copyright Holder. A Package modified in such a way shall still be considered the Standard Version.
3. You may otherwise modify your copy of this Package in any way, provided that you insert a prominent notice in each changed file stating how and when AND WHY you changed that file, and

provided that you do at least ONE of the following:

- place your modifications in the Public Domain or otherwise make them Freely Available, such as by posting said modifications to Usenet or an equivalent medium, or placing the modifications on a major archive site such as unet.net, uu.net, or by allowing the Copyright Holder to include your modifications in the Standard Version of the Package.
 - use the modified Package only within your corporation or organization.
 - rename any non-standard executables so the names do not conflict with standard executables, which must also be provided, and provide separate documentation for each non-standard executable that clearly documents how it differs from the Standard Version.
 - make other distribution arrangements with the Copyright Holder.
4. You may distribute the programs of this Package in object code or executable form, provided that you do at least ONE of the following:
- distribute a Standard Version of the executables and library files, together with instructions (in the manual page or equivalent) on where to get the Standard Version.
 - accompany the distribution with the machine-readable source of the Package with your modifications.
 - accompany any non-standard executables with their corresponding Standard Version executables, giving the non-standard executables non-standard names, and clearly documenting the differences in manual pages (or equivalent), together with instructions on where to get the Standard Version.
 - make other distribution arrangements with the Copyright Holder.
5. You may charge a reasonable copying fee for any distribution of this Package. You may charge any fee you choose for support of this Package.
- YOU MAY NOT CHARGE A FEE FOR THIS PACKAGE ITSELF. However, you may distribute this Package in aggregate with other (possibly commercial) programs as part of a larger (possibly commercial) software distribution provided that YOU DO NOT ADVERTISE this package as a product of your own.
6. The name of the Copyright Holder may not be used to endorse or promote products derived from this software without specific prior written permission.
7. THIS PACKAGE IS PROVIDED "AS IS" AND WITHOUT ANY EXPRESS OR IMPLIED WARRANTIES, INCLUDING, WITHOUT LIMITATION, THE IMPLIED WARRANTIES OF MERCHANTABILITY AND FITNESS FOR A PARTICULAR PURPOSE.

□ Exhibit-J

Unless otherwise "explicitly" stated, the following text describes the licensed conditions under which the contents of this libcap release may be used and distributed:

Redistribution and use in source and binary forms of libcap, with or without modification, are permitted provided that the following conditions are met:

- Redistributions of source code must retain any existing copyright notice, and this entire permission notice in its entirety, including the disclaimer of warranties.
- Redistributions in binary form must reproduce all prior and current copyright notices, this list of conditions, and the following disclaimer in the documentation and/or other materials provided with the distribution.
- The name of any author may not be used to endorse or promote products derived from this software without their specific prior written permission.

ALTERNATIVELY, this product may be distributed under the terms of the GNU General Public License, in which case the provisions of the GNU GPL are required INSTEAD OF the above restrictions. (This clause is necessary due to a potential conflict between the GNU GPL and the restrictions contained in a BSD-style copyright.)

THIS SOFTWARE IS PROVIDED "AS IS" AND ANY EXPRESS OR IMPLIED WARRANTIES, INCLUDING, BUT NOT LIMITED TO, THE IMPLIED WARRANTIES OF MERCHANTABILITY AND FITNESS FOR A PARTICULAR PURPOSE ARE DISCLAIMED.

IN NO EVENT SHALL THE AUTHOR(S) BE LIABLE FOR ANY

DIRECT, INDIRECT, INCIDENTAL, SPECIAL, EXEMPLARY, OR CONSEQUENTIAL DAMAGES (INCLUDING, BUT NOT LIMITED TO, PROCUREMENT OF SUBSTITUTE GOODS OR SERVICES; LOSS OF USE, DATA, OR PROFITS; OR BUSINESS INTERRUPTION) HOWEVER CAUSED AND ON ANY THEORY OF LIABILITY, WHETHER IN CONTRACT, STRICT LIABILITY, OR TORT (INCLUDING NEGLIGENCE OR OTHERWISE) ARISING IN ANY WAY OUT OF THE USE OF THIS SOFTWARE, EVEN IF ADVISED OF THE POSSIBILITY OF SUCH DAMAGE.

□ Exhibit-K

Copyright 1995 by Wietse Venema. All rights reserved. Some individual files may be covered by other copyrights.

This material was originally written and compiled by Wietse Venema at Eindhoven University of Technology, The Netherlands, in 1990, 1991, 1992, 1993, 1994 and 1995.

Redistribution and use in source and binary forms are permitted provided that this entire copyright notice is duplicated in all such copies.

This software is provided "as is" and without any expressed or implied warranties, including, without limitation, the implied warranties of merchantability and fitness for any particular purpose.

□ Exhibit-L

Copyright (c) 1989 The Regents of the University of California.

All rights reserved.

Redistribution and use in source and binary forms, with or without modification, are permitted provided that the following conditions are met:

- Redistributions of source code must retain the above copyright notice, this list of conditions and the following disclaimer.
- Redistributions in binary form must reproduce the above copyright notice, this list of conditions and the following disclaimer in the documentation and/or other materials provided with the distribution.
- All advertising materials mentioning features or use of this software must display the following acknowledgement:
This product includes software developed by the University of California, Berkeley and its contributors.
- Neither the name of the University nor the names of its contributors may be used to endorse or promote products derived from this software without specific prior written permission.
THIS SOFTWARE IS PROVIDED BY THE REGENTS AND CONTRIBUTORS "AS IS" AND ANY EXPRESS OR IMPLIED WARRANTIES, INCLUDING, BUT NOT LIMITED TO, THE IMPLIED WARRANTIES OF MERCHANTABILITY AND FITNESS FOR A PARTICULAR PURPOSE ARE DISCLAIMED. IN NO EVENT SHALL THE REGENTS OR CONTRIBUTORS BE LIABLE FOR ANY DIRECT, INDIRECT, INCIDENTAL, SPECIAL, EXEMPLARY, OR CONSEQUENTIAL DAMAGES (INCLUDING, BUT NOT LIMITED TO, PROCUREMENT OF SUBSTITUTE GOODS OR SERVICES; LOSS OF USE, DATA, OR PROFITS; OR BUSINESS INTERRUPTION) HOWEVER CAUSED AND ON ANY THEORY OF LIABILITY, WHETHER IN CONTRACT, STRICT LIABILITY, OR TORT (INCLUDING NEGLIGENCE OR OTHERWISE) ARISING IN ANY WAY OUT OF THE USE OF THIS SOFTWARE, EVEN IF ADVISED OF THE POSSIBILITY OF SUCH DAMAGE.

□ Exhibit-M

Copyright (c) 1998 Red Hat Software

Permission is hereby granted, free of charge, to any person obtaining a copy of this software and associated documentation files (the "Software"), to deal in the Software without restriction, including without limitation the rights to use, copy, modify, merge, publish, distribute, sublicense, and/or sell copies of the Software, and to permit persons to whom the Software is furnished to do so, subject to the following conditions:

The above copyright notice and this permission notice shall be included in all copies or substantial portions of the Software.

THE SOFTWARE IS PROVIDED "AS IS"; WITHOUT WARRANTY OF ANY KIND, EXPRESS OR IMPLIED, INCLUDING BUT NOT LIMITED TO THE WARRANTIES OF MERCHANTABILITY, FITNESS FOR A PARTICULAR PURPOSE AND NONINFRINGEMENT. IN NO EVENT SHALL THE X CONSORTIUM BE LIABLE FOR ANY CLAIM, DAMAGES OR OTHER LIABILITY, WHETHER IN AN ACTION OF

CONTRACT, TORT OR OTHERWISE, ARISING FROM, OUT OF OR IN CONNECTION WITH THE SOFTWARE OR THE USE OR OTHER DEALINGS IN THE SOFTWARE.

Except as contained in this notice, the name of the X Consortium shall not be used in advertising or otherwise to promote the sale, use or other dealings in this Software without prior written authorization from the X Consortium.

□ Exhibit-N

Copyright (c) 2004-2005 by Internet Systems Consortium, Inc. ("ISC")

Copyright (c) 1995-2003 by Internet Software Consortium

Permission to use, copy, modify, and distribute this software for any purpose with or without fee is hereby granted, provided that the above copyright notice and this permission notice appear in all copies.

THE SOFTWARE IS PROVIDED "AS IS" AND ISC DISCLAIMS ALL WARRANTIES WITH REGARD TO THIS SOFTWARE INCLUDING ALL IMPLIED WARRANTIES OF MERCHANTABILITY AND FITNESS. IN NO EVENT SHALL ISC BE LIABLE FOR ANY SPECIAL, DIRECT, INDIRECT, OR CONSEQUENTIAL DAMAGES OR ANY DAMAGES WHATSOEVER RESULTING FROM LOSS OF USE, DATA OR PROFITS, WHETHER IN AN ACTION OF CONTRACT, NEGLIGENCE OR OTHER TORTIOUS ACTION, ARISING OUT OF OR IN CONNECTION WITH THE USE OR PERFORMANCE OF THIS SOFTWARE.

Internet Systems Consortium, Inc.

950 Charter Street Redwood City, CA 94063

<info@isc.org> http://www.isc.org/

□ Exhibit-O

OpenBSD: telnet.c,v 1.6 1998/07/27 15:29:29 millert Exp

NetBSD: telnet.c,v 1.7 1996/02/28 21:04:15 thorpej Exp

Copyright (c) 1988, 1990, 1993

The Regents of the University of California. All rights reserved.

Redistribution and use in source and binary forms, with or without modification, are permitted provided that the following conditions are met:

- Redistributions of source code must retain the above copyright notice, this list of conditions and the following disclaimer.
- Redistributions in binary form must reproduce the above copyright notice, this list of conditions and the following disclaimer in the documentation and/or other materials provided with the distribution.
- All advertising materials mentioning features or use of this software must display the following acknowledgement:
This product includes software developed by the University of California, Berkeley and its contributors.
- Neither the name of the University nor the names of its contributors may be used to endorse or promote products derived from this software without specific prior written permission.
THIS SOFTWARE IS PROVIDED BY THE REGENTS AND CONTRIBUTORS "AS IS" AND ANY EXPRESS OR IMPLIED WARRANTIES, INCLUDING, BUT NOT LIMITED TO, THE IMPLIED WARRANTIES OF MERCHANTABILITY AND FITNESS FOR A PARTICULAR PURPOSE ARE DISCLAIMED. IN NO EVENT SHALL THE REGENTS OR CONTRIBUTORS BE LIABLE FOR ANY DIRECT, INDIRECT, INCIDENTAL, SPECIAL, EXEMPLARY, OR CONSEQUENTIAL DAMAGES (INCLUDING, BUT NOT LIMITED TO, PROCUREMENT OF SUBSTITUTE GOODS OR SERVICES; LOSS OF USE, DATA, OR PROFITS; OR BUSINESS INTERRUPTION) HOWEVER CAUSED AND ON ANY THEORY OF LIABILITY, WHETHER IN CONTRACT, STRICT LIABILITY, OR TORT (INCLUDING NEGLIGENCE OR OTHERWISE) ARISING IN ANY WAY OUT OF THE USE OF THIS SOFTWARE, EVEN IF ADVISED OF THE POSSIBILITY OF SUCH DAMAGE.

□ Exhibit-P

ORIGINAL LICENSE:

This software is

(c) Copyright 1992 by Panagiotis Tsirigotis

The author (Panagiotis Tsirigotis) grants permission to use, copy, and distribute this software and its documentation for any purpose and without fee, provided that the above copyright notice extant in files in this distribution is not removed from files included in any redistribution and that this copyright notice is also included in any redistribution.

Modifications to this software may be distributed, either by distributing the modified software or by distributing patches to the original software, under the following additional terms:

1. The version number will be modified as follows:

- The first 3 components of the version number (i.e. <number>.<number>.<number>) will remain unchanged.
- A new component will be appended to the version number to indicate the modification level. The form of this component is up to the author of the modifications.

2. The author of the modifications will include his/her name by appending it along with the new version number to this file and will be responsible for any wrong behavior of the modified software.

The author makes no representations about the suitability of this software for any purpose. It is provided "as is" without any express or implied warranty.

Modifications:

Version: 2.1.8.7-current

Copyright 1998-2001 by Rob Braun

Sensor Addition

Version: 2.1.8.9pre14a

Copyright 2001 by Steve Grubb

This is an excerpt from an email I received from the original author, allowing xinetd as maintained by me, to use the higher version numbers:

I appreciate your maintaining the version string guidelines as specified in the copyright. But I did not mean them to last as long as they did.

So, if you want, you may use any 2.N.* (N >= 3) version string for future xinetd versions that you release. Note that I am excluding the 2.2.* line; using that would only create confusion. Naming the next release 2.3.0 would put to rest the confusion about 2.2.1 and 2.1.8.*.

□ Exhibit-Q

Except where otherwise noted in the source code (e.g. the files hash.c, list.c and the trio files, which are covered by a similar licence but with different Copyright notices) all the files are:

Copyright (C) 1998-2003 Daniel Veillard. All Rights Reserved.

Permission is hereby granted, free of charge, to any person obtaining a copy of this software and associated documentation files (the "Software"), to deal in the Software without restriction, including without limitation the rights to use, copy, modify, merge, publish, distribute, sublicense, and/or sell copies of the Software, and to permit persons to whom the Software is furnished to do so, subject to the following conditions:

The above copyright notice and this permission notice shall be included in all copies or substantial portions of the Software.

THE SOFTWARE IS PROVIDED "AS IS"; WITHOUT WARRANTY OF ANY KIND, EXPRESS OR IMPLIED, INCLUDING BUT NOT LIMITED TO THE WARRANTIES OF MERCHANTABILITY, FITNESS FOR A PARTICULAR PURPOSE AND NONINFRINGEMENT. IN NO EVENT SHALL THE DANIEL VEILLARD BE LIABLE FOR ANY CLAIM, DAMAGES OR OTHER LIABILITY, WHETHER IN AN ACTION OF CONTRACT, TORT OR OTHERWISE, ARISING FROM, OUT OF OR IN CONNECTION WITH THE SOFTWARE OR THE USE OR OTHER DEALINGS IN THE SOFTWARE.

Except as contained in this notice, the name of Daniel Veillard shall not be used in advertising or otherwise to promote the sale, use or other dealings in this Software without prior written authorization from him.

□ Exhibit-R

LICENSE ISSUES

The OpenSSL toolkit stays under a dual license, i.e. both the conditions of the OpenSSL License and the original SSLeay license apply to the toolkit.

See below for the actual license texts. Actually both licenses are BSD-style Open Source licenses. In case of any license issues related to OpenSSL please contact openssl-core@openssl.org.

OpenSSL License

Copyright (c) 1998-2004 The OpenSSL Project. All rights reserved.

Redistribution and use in source and binary forms, with or without modification, are permitted provided that the following conditions are met:

1. Redistributions of source code must retain the above copyright notice, this list of conditions and the following disclaimer.
2. Redistributions in binary form must reproduce the above copyright notice, this list of conditions and the following disclaimer in the documentation and/or other materials provided with the distribution.
3. All advertising materials mentioning features or use of this software must display the following acknowledgment:
"This product includes software developed by the OpenSSL Project for use in the OpenSSL Toolkit. (<http://www.openssl.org/>)"
4. The names "OpenSSL Toolkit" and "OpenSSL Project" must not be used to endorse or promote products derived from this software without prior written permission. For written permission, please contact openssl-core@openssl.org.
5. Products derived from this software may not be called "OpenSSL" nor may "OpenSSL" appear in their names without prior written permission of the OpenSSL Project.
6. Redistributions of any form whatsoever must retain the following acknowledgment:

"This product includes software developed by the OpenSSL Project for use in the OpenSSL Toolkit (<http://www.openssl.org/>)"
THIS SOFTWARE IS PROVIDED BY THE OpenSSL PROJECT "AS IS" AND ANY EXPRESSED OR IMPLIED WARRANTIES, INCLUDING, BUT NOT LIMITED TO, THE IMPLIED WARRANTIES OF MERCHANTABILITY AND FITNESS FOR A PARTICULAR PURPOSE ARE DISCLAIMED. IN NO EVENT SHALL THE OpenSSL PROJECT OR ITS CONTRIBUTORS BE LIABLE FOR ANY DIRECT, INDIRECT, INCIDENTAL, SPECIAL, EXEMPLARY, OR CONSEQUENTIAL DAMAGES (INCLUDING, BUT NOT LIMITED TO, PROCUREMENT OF SUBSTITUTE GOODS OR SERVICES; LOSS OF USE, DATA, OR PROFITS; OR BUSINESS INTERRUPTION) HOWEVER CAUSED AND ON ANY THEORY OF LIABILITY, WHETHER IN CONTRACT, STRICT LIABILITY, OR TORT (INCLUDING NEGLIGENCE OR OTHERWISE) ARISING IN ANY WAY OUT OF THE USE OF THIS SOFTWARE, EVEN IF ADVISED OF THE POSSIBILITY OF SUCH DAMAGE.
This product includes cryptographic software written by Eric Young (eyay@cryptsoft.com). This product includes software written by Tim Hudson (tjh@cryptsoft.com).

Original SSL License

Copyright (C) 1995-1998 Eric Young (eyay@cryptsoft.com)
All rights reserved.

This package is an SSL implementation written by Eric Young (eyay@cryptsoft.com). The implementation was written so as to conform with Netscape's SSL.

This library is free for commercial and non-commercial use as long as the following conditions are adhered to. The following conditions apply to all code found in this distribution, be it the RC4, RSA, lhash, DES, etc., code; not just the SSL code. The SSL documentation included with this distribution is covered by the same copyright terms except that the holder is Tim Hudson (tjh@cryptsoft.com). Copyright remains Eric Young's, and as such any Copyright notices in the code are not to be removed.

If this package is used in a product, Eric Young should be given attribution as the author of the parts of the library used.

This can be in the form of a textual message at program startup or in documentation (online or textual) provided with the package.

Redistribution and use in source and binary forms, with or without modification, are permitted provided that the following conditions are met:

1. Redistributions of source code must retain the copyright notice, this list of conditions and the following disclaimer.
2. Redistributions in binary form must reproduce the above copyright notice, this list of conditions and the following disclaimer in the documentation and/or other materials provided with the distribution.
3. All advertising materials mentioning features or use of this software must display the following acknowledgement:
"This product includes cryptographic software written by Eric Young (eyay@cryptsoft.com)"
The word "cryptographic" can be left out if the routines from the library being used are not cryptographic related :-).
4. If you include any Windows specific code (or a derivative thereof) from the apps directory (application code) you must include an acknowledgement:

"This product includes software written by Tim Hudson (tjh@cryptsoft.com)"

THIS SOFTWARE IS PROVIDED BY ERIC YOUNG "AS IS" AND ANY EXPRESS OR IMPLIED WARRANTIES, INCLUDING, BUT NOT LIMITED TO, THE IMPLIED WARRANTIES OF MERCHANTABILITY AND FITNESS FOR A PARTICULAR PURPOSE ARE DISCLAIMED. IN NO EVENT SHALL THE AUTHOR OR CONTRIBUTORS BE LIABLE FOR ANY DIRECT, INDIRECT, INCIDENTAL, SPECIAL, EXEMPLARY, OR CONSEQUENTIAL DAMAGES (INCLUDING, BUT NOT LIMITED TO, PROCUREMENT OF SUBSTITUTE GOODS OR SERVICES; LOSS OF USE, DATA, OR PROFITS; OR BUSINESS INTERRUPTION) HOWEVER CAUSED AND ON ANY THEORY OF LIABILITY, WHETHER IN CONTRACT, STRICT LIABILITY, OR TORT (INCLUDING NEGLIGENCE OR OTHERWISE) ARISING IN ANY WAY OUT OF THE USE OF THIS SOFTWARE, EVEN IF ADVISED OF THE POSSIBILITY OF SUCH DAMAGE.

The licence and distribution terms for any publicly available version or derivative of this code cannot be changed. i.e. this code cannot simply be copied and put under another distribution licence (including the GNU Public Licence.)

Exhibit-S

Copyright (c) 1998-2001, 2002 Free Software Foundation, Inc. Permission is hereby granted, free of charge, to any person obtaining a copy of this software and associated documentation files (the "Software"), to deal in the Software without restriction, including without limitation the rights to use, copy, modify, merge, publish, distribute, distribute with modifications, sublicense, and/or sell copies of the Software, and to permit persons to whom the Software is furnished to do so, subject to the following conditions: The above copyright notice and this permission notice shall be included in all copies or substantial portions of the Software. THE SOFTWARE IS PROVIDED "AS IS," WITHOUT WARRANTY OF ANY KIND, EXPRESS OR IMPLIED, INCLUDING BUT NOT LIMITED TO THE WARRANTIES OF MERCHANTABILITY, FITNESS FOR A PARTICULAR PURPOSE AND NONINFRINGEMENT. IN NO EVENT SHALL THE ABOVE COPYRIGHT HOLDERS BE LIABLE FOR ANY CLAIM, DAMAGES OR OTHER LIABILITY, WHETHER IN AN ACTION OF CONTRACT, TORT OR OTHERWISE, ARISING FROM, OUT OF OR IN CONNECTION WITH THE SOFTWARE OR THE USE OR OTHER DEALINGS IN THE SOFTWARE.

Except as contained in this notice, the name(s) of the above copyright holders shall not be used in advertising or otherwise to promote the sale, use or other dealings in this Software without prior written authorization.

Exhibit-T

Copyright (c) 1990 The Regents of the University of California. All rights reserved.

Redistribution and use in source and binary forms, with or without modification, are permitted provided that the following conditions are met:

1. Redistributions of source code must retain the above copyright notice, this list of conditions and the following disclaimer.
2. Redistributions in binary form must reproduce the above copyright notice, this list of conditions and the following disclaimer in the documentation and/or other materials provided with the distribution.
3. All advertising materials mentioning features or use of this software must display the following acknowledgement:
This product includes software developed by the University of California, Berkeley and its contributors.
4. Neither the name of the University nor the names of its contributors may be used to endorse or promote products derived from this software without specific prior written permission.

THIS SOFTWARE IS PROVIDED BY THE REGENTS AND CONTRIBUTORS "AS IS" AND ANY EXPRESS OR IMPLIED WARRANTIES, INCLUDING, BUT NOT LIMITED TO, THE IMPLIED WARRANTIES OF MERCHANTABILITY AND FITNESS FOR A PARTICULAR PURPOSE ARE DISCLAIMED. IN NO EVENT SHALL THE REGENTS OR CONTRIBUTORS BE LIABLE FOR ANY DIRECT, INDIRECT, INCIDENTAL, SPECIAL, EXEMPLARY, OR CONSEQUENTIAL DAMAGES (INCLUDING, BUT NOT LIMITED TO, PROCUREMENT OF SUBSTITUTE GOODS OR SERVICES; LOSS OF USE, DATA, OR PROFITS; OR BUSINESS INTERRUPTION)

HOWEVER CAUSED AND ON ANY THEORY OF LIABILITY, WHETHER IN CONTRACT, STRICT LIABILITY, OR TORT (INCLUDING NEGLIGENCE OR OTHERWISE) ARISING IN ANY WAY OUT OF THE USE OF THIS SOFTWARE, EVEN IF ADVISED OF THE POSSIBILITY OF SUCH DAMAGE.

Copyright (C) 1985-2005 by the Massachusetts Institute of Technology.

All rights reserved.

Export of this software from the United States of America may require a specific license from the United States Government. It is the responsibility of any person or organization contemplating export to obtain such a license before exporting. WITHIN THAT CONSTRAINT, permission to use, copy, modify, and distribute this software and its documentation for any purpose and without fee is hereby granted, provided that the above copyright notice appear in all copies and that both that copyright notice and this permission notice appear in supporting documentation, and that the name of M.I.T. not be used in advertising or publicity pertaining to distribution of the software without specific, written prior permission. Furthermore if you modify this software you must label your software as modified software and not distribute it in such a fashion that it might be confused with the original MIT software.

M.I.T. makes no representations about the suitability of this software for any purpose. It is provided "as is" without express or implied warranty.

THIS SOFTWARE IS PROVIDED "AS IS" AND WITHOUT ANY EXPRESS OR IMPLIED WARRANTIES, INCLUDING, WITHOUT LIMITATION, THE IMPLIED WARRANTIES OF MERCHANTABILITY AND FITNESS FOR A PARTICULAR PURPOSE.

Individual source code files are copyright MIT, Cygnus Support, OpenVision, Oracle, Sun Soft, FundsXpress, and others.

Project Athena, Athena, Athena MUSE, Discuss, Hesiod, Kerberos, Moira, and Zephyr are trademarks of the Massachusetts Institute of Technology (MIT). No commercial use of these trademarks may be made without prior written permission of MIT.

"Commercial use" means use of a name in a product or other for-profit manner. It does NOT prevent a commercial firm from referring to the MIT trademarks in order to convey information (although in doing so, recognition of their trademark status should be given).

The following copyright and permission notice applies to the OpenVision Kerberos Administration system located in `admin/`, `create`, `admin/dbutil`, `admin/passwd`, `admin/server`, `lib/kadm5`, and portions of `lib/rpc`:

Copyright, OpenVision Technologies, Inc., 1996, All Rights Reserved

WARNING: Retrieving the OpenVision Kerberos Administration system source code, as described below, indicates your acceptance of the following terms. If you do not agree to the following terms, do not retrieve the OpenVision Kerberos administration system.

You may freely use and distribute the Source Code and Object Code compiled from it, with or without modification, but this Source Code is provided to you "AS IS" EXCLUSIVE OF ANY WARRANTY, INCLUDING, WITHOUT LIMITATION, ANY WARRANTIES OF MERCHANTABILITY OR FITNESS FOR A PARTICULAR PURPOSE, OR ANY OTHER WARRANTY, WHETHER EXPRESS OR IMPLIED. IN NO EVENT WILL OPENVISION HAVE ANY LIABILITY FOR ANY LOST PROFITS, LOSS OF DATA OR COSTS OF PROCUREMENT OF SUBSTITUTE GOODS OR SERVICES, OR FOR ANY SPECIAL, INDIRECT, OR CONSEQUENTIAL DAMAGES ARISING OUT OF THIS AGREEMENT, INCLUDING, WITHOUT LIMITATION, THOSE RESULTING FROM THE USE OF THE SOURCE CODE, OR THE FAILURE OF THE SOURCE CODE TO PERFORM, OR FOR ANY OTHER REASON.

OpenVision retains all copyrights in the donated Source Code. OpenVision also retains copyright to derivative works of the Source Code, whether created by OpenVision or by a third party. The OpenVision copyright notice must be preserved if derivative works are made based on the donated Source Code. OpenVision Technologies, Inc. has donated this Kerberos Administration system to MIT for inclusion in the standard Kerberos 5 distribution. This donation underscores our commitment to continuing Kerberos technology development and our gratitude for the valuable work which has been performed by MIT and the Kerberos community.

Portions contributed by Matt Crawford <crawdad@fnal.gov> were work performed at Fermi National Accelerator Laboratory, which is operated by Universities Research Association, Inc., under contract DE-AC02-76CHO3000 with the U.S. Department of Energy.

The implementation of the Yarrow pseudo-random number generator in `src/lib/crypto/yarrow` has the following copyright:

Copyright 2000 by Zero-Knowledge Systems, Inc.

Permission to use, copy, modify, distribute, and sell this software and its documentation for any purpose is hereby granted without fee, provided that the above copyright notice appear in all copies and that both that copyright notice and this permission notice appear in supporting documentation, and that the name of Zero-Knowledge Systems, Inc. not be used in advertising or publicity pertaining to distribution of the software without specific, written prior permission. Zero-Knowledge Systems, Inc. makes no representations about the suitability of this software for any purpose. It is provided "as is" without express or implied warranty.

ZERO-KNOWLEDGE SYSTEMS, INC. DISCLAIMS ALL WARRANTIES WITH REGARD TO THIS SOFTWARE, INCLUDING ALL IMPLIED WARRANTIES OF MERCHANTABILITY AND FITNESS, IN NO EVENT SHALL ZERO-KNOWLEDGE SYSTEMS, INC. BE LIABLE FOR ANY SPECIAL, INDIRECT OR CONSEQUENTIAL DAMAGES OR ANY DAMAGES WHATSOEVER RESULTING FROM LOSS OF USE, DATA OR PROFITS, WHETHER IN AN ACTION OF CONTRACT, NEGLIGENCE OR OTHER TORTUOUS ACTION, ARISING OUT OF OR IN CONNECTION WITH THE USE OR PERFORMANCE OF THIS SOFTWARE.

The implementation of the AES encryption algorithm in

`src/lib/crypto/aes` has the following copyright:

Copyright (c) 2001, Dr Brian Gladman <brg@gladman.uk.net>, Worcester, UK.

All rights reserved.

LICENSE TERMS

The free distribution and use of this software in both source and binary form is allowed (with or without changes) provided that:

1. distributions of this source code include the above copyright notice, this list of conditions and the following disclaimer;
2. distributions in binary form include the above copyright notice, this list of conditions and the following disclaimer in the documentation and/or other associated materials;
3. the copyright holder's name is not used to endorse products built with this software without specific written permission.

DISCLAIMER

This software is provided "as is" with no explicit or implied warranties in respect of any properties, including, but not limited to, correctness and fitness for purpose.

The implementation of the RPCSEC_GSS authentication flavor in `src/lib/rpc` has the following copyright:

Copyright (c) 2000 The Regents of the University of Michigan.

All rights reserved.

Copyright (c) 2000 Dug Song <dugsong@UMICH.EDU>.

All rights reserved, all wrongs reversed.

Redistribution and use in source and binary forms, with or without modification, are permitted provided that the following conditions are met:

1. Redistributions of source code must retain the above copyright notice, this list of conditions and the following disclaimer.
2. Redistributions in binary form must reproduce the above copyright notice, this list of conditions and the following disclaimer in the documentation and/or other materials provided with the distribution.
3. Neither the name of the University nor the names of its contributors may be used to endorse or promote products derived from this software without specific prior written permission.

THIS SOFTWARE IS PROVIDED "AS IS" AND ANY EXPRESS OR IMPLIED WARRANTIES, INCLUDING, BUT NOT LIMITED TO, THE IMPLIED WARRANTIES OF MERCHANTABILITY AND FITNESS FOR A PARTICULAR PURPOSE ARE DISCLAIMED. IN NO EVENT SHALL THE REGENTS OR CONTRIBUTORS BE LIABLE FOR ANY DIRECT, INDIRECT, INCIDENTAL, SPECIAL, EXEMPLARY, OR CONSEQUENTIAL DAMAGES (INCLUDING, BUT NOT LIMITED TO, PROCUREMENT OF SUBSTITUTE GOODS OR SERVICES; LOSS OF USE, DATA, OR PROFITS; OR BUSINESS INTERRUPTION) HOWEVER CAUSED AND ON ANY THEORY OF LIABILITY,

WHETHER IN CONTRACT, STRICT LIABILITY, OR TORT (INCLUDING NEGLIGENCE OR OTHERWISE) ARISING IN ANY WAY OUT OF THE USE OF THIS SOFTWARE, EVEN IF ADVISED OF THE POSSIBILITY OF SUCH DAMAGE.

Acknowledgments

Appreciation Time!!!! There are far too many people to try to thank them all; many people have contributed to the development of Kerberos V5. This is only a partial listing....

Thanks to Kevin Coffman and the CITI group at the University of Michigan for providing patches for implementing RPCSEC_GSS authentication in the RPC library.

Thanks to Derrick Schommer for reporting multiple memory leaks.

Thanks to Quanah Gibson-Mount of Stanford University for helping exercise the thread support code.

Thanks to Michael Tautschnig for reporting the heap buffer overflow in the password history mechanism. [MITKRB5-SA-2004-004]

Thanks to Wyllys Ingersoll for finding a buffer-size problem in the RPCSEC_GSS implementation.

Thanks to the members of the Kerberos V5 development team at MIT, both past and present: Danilo Almeida, Jeffrey Altman, Jay Berkenbilt, Richard Basch, Mitch Berger, John Carr, Don Davis, Alexandra Ellwood, Nancy Gilman, Matt Hancher, Sam Hartman, Paul Hill, Marc Horowitz, Eva Jacobus, Miroslav Jurisic, Barry Jaspan, Geoffrey King, John Kohl, Peter Litwack, Scott McGuire, Kevin Mitchell, Cliff Neuman, Paul Park, Ezra Peisach, Chris Provenzano, Ken Raeburn, Jon Rochlis, Jeff Schiller, Jen Selby, Brad Thompson, Harry Tsai, Ted Ts'o, Marshall Vale, Tom Yu.

Very special thanks go to Marshall Vale, our departing team leader.

Over the past few years, Marshall has been extremely valuable to us as mentor, advisor, manager, and friend. Marshall's devotion as a champion of Kerberos has helped our team immensely through many trials and hardships. We will miss him tremendously, and we wish him the best in his future endeavors.

□ Exhibit-U

Copyright (c) 1989 The Regents of the University of California.

All rights reserved.

This code is derived from software contributed to Berkeley by Mike Muuss.

Redistribution and use in source and binary forms, with or without modification, are permitted provided that the following conditions are met:

1. Redistributions of source code must retain the above copyright notice, this list of conditions and the following disclaimer.
2. Redistributions in binary form must reproduce the above copyright notice, this list of conditions and the following disclaimer in the documentation and/or other materials provided with the distribution.
3. All advertising materials mentioning features or use of this software must display the following acknowledgement:
This product includes software developed by the University of California, Berkeley and its contributors.
4. Neither the name of the University nor the names of its contributors may be used to endorse or promote products derived from this software without specific prior written permission.

THIS SOFTWARE IS PROVIDED BY THE REGENTS AND CONTRIBUTORS "AS IS" AND ANY EXPRESS OR IMPLIED WARRANTIES, INCLUDING, BUT NOT LIMITED TO, THE IMPLIED WARRANTIES OF MERCHANTABILITY AND FITNESS FOR A PARTICULAR PURPOSE ARE DISCLAIMED. IN NO EVENT SHALL THE REGENTS OR CONTRIBUTORS BE LIABLE FOR ANY DIRECT, INDIRECT, INCIDENTAL, SPECIAL, EXEMPLARY, OR CONSEQUENTIAL DAMAGES (INCLUDING, BUT NOT LIMITED TO, PROCUREMENT OF SUBSTITUTE GOODS OR SERVICES; LOSS OF USE, DATA, OR PROFITS; OR BUSINESS INTERRUPTION) HOWEVER CAUSED AND ON ANY THEORY OF LIABILITY, WHETHER IN CONTRACT, STRICT LIABILITY, OR TORT (INCLUDING NEGLIGENCE OR OTHERWISE) ARISING IN ANY WAY OUT OF THE USE OF THIS SOFTWARE, EVEN IF ADVISED OF THE POSSIBILITY OF SUCH DAMAGE.

License Information for the Software Used in the Unit

About GPL (GNU-General Public License), LGPL (GNU Lesser General Public License) License

This product uses GPL/LGPL software and software made by other companies.

After you purchase this product, you may procure, modify or distribute the source code of the GPL/LGPL software that is used in the product.

DENON provides the source code based on the GPL and LPGL licenses at the actual cost upon your request to our customer service center. However, note that we make no guarantees concerning the source code. Please also understand that we do not offer support for the contents of the source code.

DEVICE SELECT : TV

Television

A	3M	100
	Addison	163
	Admiral	033, 044, 050, 141
	Advent	130
	Adventura	041
	Aiko	138
	Akai	018, 019, 034, 119, 137, 151
	Albatron	127, 131
	Alleron	039
	America Action	139
	Ampro	129
	Amtron	038
	Anam	139
	Anam National	035, 038
	AOC	030, 036, 079, 137, 151, 154
	Apex	048, 062
	Apex Digital	174
	Audiovox	038, 067, 071, 138, 139, 140
	Aventura	029
	Axion	120
B	Bang & Olufsen	146
	Barco	020
	Baur	034
	Belcor	030
	Bell & Howell	033
	Benq	089, 135
	Blue Sky	020
	Bradford	038, 139
	Brilliant	145
	Brockwood	030
	Broksonic	050, 139, 141
	byd:sign	123
C	Candle	037, 041, 137, 151
	Carnivale	137, 151
	Carver	155
	CCE	147, 152
	Celebrity	034
	Celera	048
	Changhong	048
	Ching Tai	163
	Chun Yun	157, 163, 169, 173
	Chung Hsin	160, 169
	Citizen	037, 038, 049, 137, 138, 151, 153, 156
	Clarion	139

	Coby	074
	Contec	139
	Contec/Cony	038
	Craig	038, 139
	Crosley	049, 155
	Crown	038, 139, 153
	CTX	082
	Curtis Mathes	010, 019, 044, 137, 140, 143, 151, 153, 155, 156
	CXC	038, 139
	Cytron	118
D	Daewoo	030, 036, 049, 138, 140, 153
	Daytron	030
	Dell	012, 032
	Denon	143
	DiamondVision	125
	Dimensia	010
	Disney	060
	Dumont	013, 030
	Durabrand	012, 029, 050, 111, 136, 139, 141
	Dwin	044, 128
E	Electroband	034
	Electrograph	142
	Electrohome	034, 035, 050
	Element	106
	Emerson	012, 029, 030, 038, 039, 049, 050, 139, 141, 153
	Emprex	124
	Envision	137, 151
	Epson	080, 097
	Erres	149
	ESA	018, 029
	Ether	158
F	Firststar	170
	Fujitsu	037, 039, 077
	Funai	029, 038, 039, 139
	Furi	165
	Futuretech	038, 139
G	Gateway	085, 142, 144
	GE	010, 012, 035, 040, 045, 055, 140
	GFM	027, 028
	Gibraltar	013, 030, 137, 151
	Go Video	134
	Goldstar	012, 030, 036, 137, 151
	Gradiente	084
	Grundig	152
	Grunpy	038, 039, 139
H	Haier	107, 114, 136, 148
	Hallmark	012

	Hankook	158, 168, 169
	Harman/Kardon	155
	Harvard	038, 139
	Havermy	044
	Hello Kitty	140
	Hewlett Packard	068
	Hisense	087, 167, 174
	Hitachi	[014]*, 058, 103, 143, 181
	HP	031
	Hyundai	133
I	Ilo	090, 115, 117, 122
	IMA	038
	Infinity	155
	InFocus	099
	Initial	117
	Innova	152
	Insignia	029, 108, 109, 110
J	Janeil	041
	JBL	155
	JC Penney	010, 036, 037, 040
	JCB	034
	Jean	159, 163, 167, 170
	Jinxing	161, 165, 167
	JVC	023, 024, 025, 040, 050
K	Kawasho	034
	Kaypani	154
	KEC	139
	Kenwood	030, 137, 151
	Kioto	020, 155
	KLH	048
	Kloss Novabeam	038, 041
	Kolin	166, 169
	KTV	038, 137, 139, 147, 151, 153
L	LG	012, 030, 036, 127, 151
	Logik	033
	LXI	010, 012, 155
M	M & S	155
	Magnasonic	049
	Magnavox	028, 037, 047, 054, 056, 137, 151, 155
	Majestic	033
	Marantz	046, 137, 151, 152, 155
	Maxent	112, 142
	Mediator	149
	Megapower	127
	Megatron	012, 143
	Memorex	012, 029, 033, 036, 050, 141
	MGA	012, 030, 036, 137, 151
	Megatron	013, 040, 153
	Mintek	117

	Mitsubishi	012, 030, 036, 044, 057, 178
	Monivision	127, 131
	Montgomery Ward	033
	Motorola	035, 044
	MTC	030, 036, 137, 151, 156
	Multitech	038, 139, 147
N	NAD	012, 152
	NEC	030, 035, 036, 081, 137, 151
	Netsat	152
	Net-TV	090, 142
	Newave	163, 164, 168
	Nikko	012, 137, 138, 151
	Norcent	079, 174
	Norwood Micro	090
	Noshi	150
	NTC	138
O	Olevia	064, 072, 078
	Onwa	038, 139
	Oppo	121
	Optoma	098
	Optonica	044
	Orion	050, 141
	Otto Versand	034
P	Panasonic	007, 008, 009, 035, 040, 059, 069, 176
	Penney	012, 030, 137, 150, 151, 153, 156
	Philco	030, 035, 036, 037, 050, 137, 151, 155
	Philips	020, 021, 022, 035, 037, 046, 066, 105, 149, 152, 155
	Philips Magnavox	020, 046, 047
	Phonola	149
	Pilot	030, 137, 151, 153
	Pioneer	180, 184
	Polaroid	030, 048, 075
	Portland	030, 036, 138, 153
	Prima	083, 130
	Princeton	127
	Prism	040
	Proscan	010
	Proton	012, 154
	Protron	073
	Proview	086, 106
	Pulsar	013, 030
	Pye	149
Q	Quasar	035, 040
	Quelle	034
R	Radio Shack/Realistic	010, 038
	Radiola	149
	RadioShack	012, 030, 137, 139, 151, 153

	RCA	010, 011, 030, 035, 036, 043, 045, 150, 156
	Realistic	012, 030, 137, 139, 151, 153
	Runco	013, 137, 151
S	Sampo	137, 142, 151, 153, 154
	Samsung	012, 018, 019, 030, 036, 101, 102, 137, 147, 151, 152, 156
	Samsux	153
	Sansui	050, 141
	Sanyo	092
	SBR	149
	Sceptre	096
	Scimitsu	030
	Scotch	012
	Scott	012, 030, 038, 039, 116, 139
	Sears	010, 012, 029, 039, 088, 155
	SEI	034
	Sharp	015, 016, 017, 044, 070, 153, 179, 183
	Shen Ying	163
	Sheng Chia	044, 164
	Shogun	030
	Signature	033
	Simpson	037
	Sinudyne	034
	SKY	152
	Skygiant	169
	Sony	000, 001, 002, 034, 052, 053, 175, 182
	Soundesign	012, 037, 038, 039, 139
	Sova	073
	Sowa	162, 167
	Squareview	029
	SSS	030, 038, 139
	Starlite	038, 139
	Studio Experience	131
	Superscan	044
	Supre-Macy	041
	Supreme	034
	SVA	020, 113, 148, 174
	Sylvania	026, 027, 028, 029, 037, 063, 104, 137, 151, 155
	Symphonic	029, 038, 139
	Synco	157, 162, 163, 164, 168, 172
	Syntax	072
	Syntax-Brilliant	072, 088
T	Tacico	163, 168
	Tandy	044
	Tatung	035, 090, 144, 159, 162, 167
	Technics	040
	Techview	132

Techwood	040
Teco	159, 164, 168
Teknika	030, 033, 036, 037, 038, 039, 138, 139, 153, 155, 156
Telefunken	019
TMK	012
Toshiba	003, 004, 005, 006, 030, 051, 156, 177
Totevision	153
Trutech	091
Tuntex	158, 163
TVS	050, 141
U US Logic	090
V Vector Research	137, 151
Vidikron	155
Vidtech	012, 030, 036
Viewsonic	061, 076, 142
Viking	041
Viore	115
Vizio	061, 093, 094, 095, 126, 144
W Wards	010, 012, 030, 033, 036, 039, 137, 151, 155
Westinghouse	061, 065, 140
White Westinghouse	049, 050, 141
Y Yamaha	030, 036, 137, 151
Yapshe	171
Z Zenith	012, 013, 014, 030, 033, 042, 050, 138, 141

DEVICE SELECT : SAT/CBL

Satellite Receiver

A AccessHD	109
Alpha Digital	109
Alphastar	083
Artec	106
C CaptiveWorks	102
Channel Master	111
Chaparral	077
Coolsat	103
Coship	114
Crossdigital	120
D Digital Stream	110
DIRECTV	058, 059, 060, 061, 062, 063, 064, 068, 069, 073, 074, 075, 076, 088, 089, 090, 093, 095, 116
Dish Network	052, 053, 054, 055, 065, 091, 115, 119
Dishpro	115, 119
Drake	078
E EchoStar	052, 065, 091, 115, 119
Expressvu	119

G GE	056, 057, 112
General Instrument	079, 117
GOI	119
Goodmind	112
H Hisense	118
Hitachi	074, 084
HTS	119
Hughes Network Systems	060, 062, 067, 068, 070, 075, 093
Humax	104
I Ilo	118
Insignia	096
J Jerrold	117
JVC	052, 065, 091, 119
L Lasonic	113
LG	096, 105
M Magnavox	073, 107
Memorex	073
MicroGem	108
Mitsubishi	068, 099
Motorola	117
N Next Level	117
P Panasonic	061, 095, 097
Pansat	100
Paysat	073
PCT	111
Philco	107
Philips	060, 067, 068, 070, 072, 073, 090
Pioneer	060
Primestar	082
Proscan	056, 057
Proton	118
R RadioShack	117
RCA	056, 057, 058, 070, 076, 086, 087, 088, 089, 092
Realistic	080
S Samsung	060, 062, 069, 070, 071, 094
Sharp	098
Sony	059, 066, 116
Star Choice	117
STS	085
T Tivax	109
Tivo	060, 070
Toshiba	063
U UltimateTV	116
Uniden	073, 081
US Digital	118
V Viewsat	101
Voom	117
Z Zenith	064, 096

Cable TV

A ABC	[009]*, 010, 012, 028, 040
Adelphia	007
Americast	047
Antronix	014, 015
Archer	015
AT&T	003
B Bell South	047
C Cable Vision	006
Cabletenna	014
Cableview	013
Clearmaster	046
ClearMax	046
Colour Voice	016
Comcast	000, 005, 033
Comtronics	017
Contec	018
Coolmax	046
COX	005
D Daeryung	036
Director	033
Dumont	051
E Eastern	019
Everquest	041
F Focus	045
G GC Electronics	015
GE	009, 010
Gehua	033
Gemini	020, 041
General Instrument	005, 010, 033, 044
Goldstar	042
H Hamlin	021
Hitachi	010
J Jasco	041
Jerrold	005, 010, 020, 028, 029, 033, 041, 044
L LG	050
M Magnavox	022
MegaCable	005
Memorex	023, 040
Motorola	000, 003, 005, 033, 037, 039, 044
Movie Time	024
Multitech	046
N NEC	011
NET Brazil	035
NSC	024
O Oak	018
P Pace	008, 043
Panasonic	026, 027, 040
Paragon	040
Philips	016, 022

Pioneer	002, 030, 036, 042
Popular Mechanics	045
Proscan	009, 010
Pulsar	040
Q Quasar	040
R RadioShack	041, 046
RCA	013, 027
Realistic	015
Recoton	045
Regal	021
Regency	019
Rembrandt	010
Runco	040
S Samsung	008, 034, 042
Scientific Atlanta	001, 002, 003, 007, 012, 036, 038
Signal	020, 041
Signature	010
Sony	006, 048
Sprucer	027
Standard Component	025
Starcom	020, 028, 041
Stargate	020, 041
Starquest	020, 041
Supercable	044
Supermax	046
T Time Warner	004
Tocom	031
Torx	049
Toshiba	040
Trans PX	044
Tristar	046
TS	049
Tusa	020, 041
TV86	024
U Unika	014, 015
United Cable	028
Universal	014, 015
V V2	046
View Star	018, 022, 024
Viewmaster	046
Vision	046
Vortex View	046
Z Zenith	032, 040, 047
Zentek	045

[]*: Preset codes set upon shipment from the factory.

[]*: Les codes pré-réglés diffèrent en fonction des livraisons de l'usine.

[]*: Los códigos vienen preprogramados de fábrica.

DENON

www.denon.com

D&M Holdings Inc.
Printed in China 5411 10392 008D

