

SEARS

**OWNERS
MANUAL**

**MODEL NO.
917.255915**

**Caution:
Read Rules for
Safe Operation
and Instructions
Carefully**



**GT 18 TWIN
6 SPEED
GARDEN TRACTOR**

**Assembly
Installation
Operation
Repair Parts**

CONGRATULATIONS on your purchase of a Sears GT 18 Garden Tractor. It has been designed, engineered and manufactured to give you dependability and performance. Should you experience any problem you cannot easily remedy, please contact your nearest Sears Service Center. They have competent, well-trained technicians and the proper tools and parts to service or repair this unit.

Please read and retain this manual. The instructions will enable you to assemble, operate and maintain your Tractor properly. Always observe the "RULES FOR SAFE OPERATION"

YOUR NEW GT 18 GARDEN TRACTOR FEATURES...

CRAFTSMAN 18 H.P. TWIN-CYLINDER ENGINE--cool-running performance and long life with plenty of power to take on a variety of yard, gardening or snow removal tasks.

INTERLOCK SWITCH SYSTEM--allows engine to start only when tractor Clutch-Brake Pedal is depressed and Attachment Clutch Switch is in "OFF" position.

ALL GEAR TRANSMISSION--six speeds forward, two reverse speeds--to let you select the proper match for the terrain and the job. Automotive-type differential helps guard against turf scuffing.

CONTROL PANEL--with Throttle, Choke, Light Switch, Ignition Switch, Ammeter, Parking Brake Lever and Clutch Switch--conveniently grouped for ease of use.

MODEL
NUMBER _____
SERIAL
NUMBER _____

THE MODEL AND SERIAL NUMBERS WILL BE FOUND ON THE MODEL PLATE ATTACHED TO THE FENDER.

YOU SHOULD RECORD BOTH MODEL AND SERIAL NUMBERS AND KEEP IN A SAFE PLACE FOR FUTURE REFERENCE

ATTACHMENT VERSATILITY--handles a large variety of Sears Yard and Garden Tractor Attachments including

44 INCH MOWER with three "high-lift" blades to stand grass up for level cuts

OTHER SOIL TILLAGE ATTACHMENTS including Plow, Disc Harrow, Drag Harrow and Cultivator

46 INCH DOZER BLADE levels or moves dirt and gravel or removes snow.

40 INCH SNOW BLOWER handles wet, heavy powdery snow with ease

REAR GRADER AND LEVELER BLADE levels new yards, grading lanes, driveways and parking areas.

LIMITED TWO YEAR WARRANTY ON ELECTRIC START RIDING EQUIPMENT

For two years from date of purchase, when this riding equipment is maintained, lubricated, and tuned up according to the operating and maintenance instructions in the owner's manual, Sears will repair free of charge any defect in material or workmanship in this electric start riding equipment.

This warranty excludes blade(s), blade adapter(s), spark plug(s), air cleaner(s) and belt(s), which are expendable and become worn during normal use.

This warranty does not cover:

- tire replacement or repair caused by punctures from outside objects (such as nails, thorns, stumps, or glass); and
- repairs necessary because of operator abuse or negligence, including the failure to maintain the equipment according to instructions contained in the owner's manual; and
- riding equipment used for commercial or rental purposes

FULL 90-DAY WARRANTY ON BATTERY

For 90 days from the date of purchase, if any battery included with this riding equipment proves defective in material or workmanship and our testing determines the battery will not hold a charge, Sears will replace the battery at no charge.

WARRANTY SERVICE IS AVAILABLE BY CONTACTING THE NEAREST SEARS SERVICE CENTER/DEPARTMENT IN THE UNITED STATES. This warranty applies only while this product is in use in the United States.

This warranty gives you specific legal rights, and you may also have other rights which vary from state to state.

Sears, Roebuck and Co., D/698-731A, Sears Tower, Chicago, IL 60684

TABLE OF CONTENTS

RULES FOR SAFE OPERATION	BELOW	MAINTENANCE INSTRUCTIONS.	13
ASSEMBLY INSTRUCTIONS	4	TROUBLE SHOOTING	25
OPERATION INSTRUCTIONS	7	REPAIR PARTS	27

RULES FOR SAFE OPERATION

1. Know the controls and how to stop quickly. READ THIS OPERATOR'S MANUAL and instructions furnished with attachments.
2. Do not allow children to operate the machine. Do not allow adults to operate it without proper instruction.
3. Do not carry passengers. Do not mow when children and others are around.
4. Always wear substantial footwear. Do not wear loose fitting clothing that could get caught in moving parts.
5. Keep your eyes and mind on your tractor, mower and the area being cut. Don't let other interests distract you.
6. Do not attempt to operate your tractor or mower when not in the drivers seat.
7. Always get on or off your tractor from the operators left hand side.
8. Clear the work area of objects (wire, rocks, etc.) which might be picked up and thrown.
9. Disengage all attachment clutches before attempting to start the engine.
10. Disengage power to attachments and stop the engine before leaving the operator's position.
11. Disengage power to mower, stop the engine and disconnect spark plug wire(s) from spark plug(s) before cleaning, making an adjustment or repairs.
12. Disengage power to attachments when transporting or not in use.
13. Take all possible precautions when leaving the vehicle unattended. Disengage the power-take-off, lower the attachments, return drive control lever to neutral, shift into neutral, set the parking brake, stop the engine and remove the key.
14. Do not stop or start suddenly when going uphill or downhill. Mow up and down the face of slopes (not greater than 15°); never across the face. Refer to page 47.
15. Reduce speed on slopes and make turns gradually to prevent tipping or loss of control. Exercise extreme caution when changing direction on slopes.
16. While going up or down slopes, place Gear Shift Control Lever in 1st gear and Range Shift Lever in "LO" (Low) position to negotiate the slope without stopping.
17. Never mow in wet or slippery grass, when traction is unsure or at a speed which could cause a skid.
18. Stay alert for holes in the terrain and other hidden hazards. Keep away from drop-offs.
19. Do not drive too close to creeks, ditches and public highways.
20. Exercise special care when mowing around fixed objects in order to prevent the blades from striking them. Never deliberately run tractor or mower into or over any foreign object.
21. Never shift gears until tractor comes to a stop.
22. Never place hands or feet under the mower, in discharge chute or near any moving parts while tractor or mower are running. Always keep clear of discharge chute.
23. Use care when pulling loads or using heavy equipment.
 - a. Use only approved drawbar hitch points.
 - b. Limit loads to those you can safely control.
 - c. Do not turn sharply. Use care when backing.
 - d. Use counterweight or wheel weights when suggested in the owner's manual.
24. Watch out for traffic when crossing or near roadways.
25. When using any attachments, never direct discharge of material toward bystanders nor allow anyone near the vehicle while in operation.
26. Handle gasoline with care - it is highly flammable.
 - a. Use approved gasoline containers.
 - b. Never remove the fuel cap of the fuel tank or add gasoline to a running or hot engine or an engine that has not been allowed to cool for several minutes after running. Never fill the tank indoors, always clean up spilled gasoline.
 - c. Open doors if the engine is run in the garage - exhaust fumes are dangerous. Do not run the engine indoors.
27. Keep the vehicle and attachments in good operating condition, and keep safety devices in place and working.
28. Keep all nuts, bolts and screws tight to be sure the equipment is in safe working condition.
29. Never store the equipment with gasoline in the tank inside a building where fumes may reach an open flame or spark. Allow the engine to cool before storing in any enclosure.
30. To reduce fire hazard, keep the engine free of grass, leaves or excessive grease. Do not clean product while engine is running.
31. Except for adjustment; DO NOT operate Engine if air cleaner or cover directly over carburetor air intake is removed. Removal of such part could create a fire hazard.
32. Do not operate without a muffler or tamper with the exhaust system. Damaged mufflers or spark arresters could create a fire hazard. Inspect periodically and replace if necessary.
33. The vehicle and attachments should be stopped and inspected for damage after striking a foreign object and the damage should be repaired before restarting and operating the equipment.
34. Do not change the engine governor settings or overspeed the engine; severe damage or injury may result.
35. When using the vehicle with mower, proceed as follows:
 - a. Mow only in daylight or in good artificial light.
 - b. Shut the engine off when unclogging chute.
 - c. Check the blade mounting bolts for proper tightness at frequent intervals.
36. Do not operate the mower without the deflector shield in place.
37. Disengage power to mower before backing up. Do not mow in reverse unless absolutely necessary and then only after careful observation of the entire area behind the mower.
38. Under normal usage the grass catcher bag material is subject to deterioration and wear. It should be checked frequently for bag replacement. Replacement bags should be checked to ensure compliance with the original manufacturer's recommendations or specifications.



LOOK FOR THIS SYMBOL TO POINT OUT IMPORTANT SAFETY PRECAUTIONS. IT MEANS -- ATTENTION! BECOME ALERT! YOUR SAFETY IS INVOLVED.

WARNING

This unit is equipped with an internal combustion engine and should not be used on or near any unimproved forest-covered, brush covered or grass-covered land unless the engine's exhaust system is equipped with a spark arrester meeting applicable local or state laws (if any). If a spark arrester is used, it should be maintained in effective working order by the operator.

In the State of California the above is required by law (Section 4442 of the California Public Resources Code). Other states may have similar laws. Federal laws apply on federal lands. See your Authorized Service Center for spark arrester muffler part number 674A380.

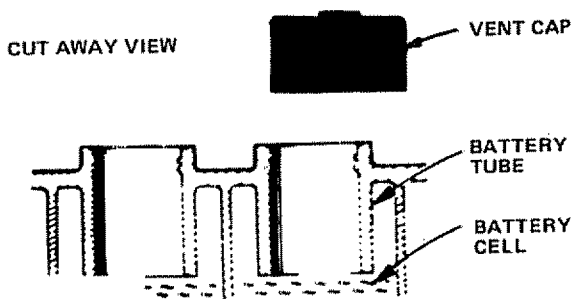

FIGURE 1

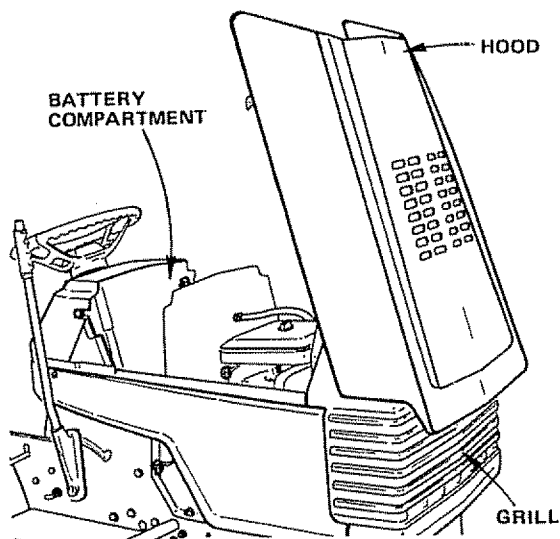

FIGURE 2

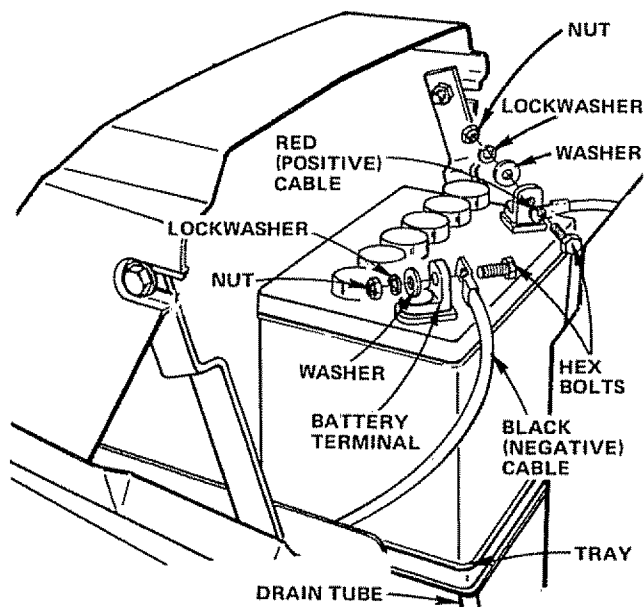



FIGURE 3

ASSEMBLY

To assemble and adjust your Tractor you will need: two 7/16" wrenches, one 9/16" wrench and a utility knife

NOTE: RIGHT HAND (R.H.) AND LEFT HAND (L.H.) ARE DETERMINED FROM OPERATOR'S POSITION WHILE SEATED ON THE TRACTOR.

1. Remove Battery, Steering Wheel, Seat and Bag of Parts. Cut down four corners of carton with utility knife, and fold down carton sides. Remove Banding holding Mower Deck in place and lower Deck down to the floor. Turn the Deck over so the Blades are down. Disengage the Parking Brake and roll the Tractor off the skid. Be careful that you do not step on or roll the Tractor over any carton staples



READ THE INSTRUCTIONS INCLUDED WITH THE BATTERY ACID CONTAINER. ALWAYS WEAR GLOVES, CLOTHING AND GOGGLES TO PROTECT YOUR HANDS, SKIN AND EYES. WASH HANDS OR CLOTHING IMMEDIATELY IF ACCIDENTALLY IN CONTACT WITH ELECTROLYTE. DO NOT SMOKE, FUMES FROM CHARGED ELECTROLYTE ARE EXPLOSIVE.

2. Fill and charge Battery (before installing). NOTE: SEE DETAILED INSTRUCTIONS PACKAGED WITH BATTERY VENT CAPS IN BAG OF PARTS.
 - a. Fill Battery with electrolyte to bottoms of tubes in cells (Fig. 1) NOTE: DO NOT OVERFILL. OVERFILLING WILL RESULT IN DAMAGE TO TRACTOR.
 - b. Check level of electrolyte after 30 minutes. Add additional electrolyte if necessary. NOTE: TIGHTEN VENT CAPS SECURELY.
 - c. Charge Battery at a rate of 6 amperes for one hour.
 - d. Neutralize excess electrolyte for disposal by adding it to four inches of water in a five gallon plastic container. Stir with a wooden or plastic paddle while adding baking soda until the addition of more soda causes no more foaming.



DO NOT SHORT BATTERY TERMINALS. BEFORE INSTALLING BATTERY, REMOVE METAL BRACELETS, WRIST-WATCH BANDS, RINGS, ETC. FROM YOUR PERSON.

3. Install Battery.
 - a. Lift hood from rear sides (Fig. 2).
 - b. Remove tape from Plastic Tray. Make sure Drain Tube (Fig. 3) is fastened to Drain Hole in Battery Tray and Battery Tray is positioned in hole of Battery Support.
 - c. Place Battery in Plastic Tray (Battery Terminals to front of Tractor) (Fig. 3)
4. Connect Battery Cables using: two Hex Bolts, two Flat Washers, two Lockwashers and two Hex Nuts (shown full size below) found in Bag of Parts.





POSITIVE TERMINAL MUST BE CONNECTED FIRST TO PREVENT SPARKS FROM ACCIDENTAL GROUNDING.

- a. Connect RED Battery Cable to Positive (+) Battery Terminal with Hex Bolt, Flat Washer, Lockwasher and Hex Nut (Fig. 3). Tighten securely.
- b. Connect BLACK Ground Cable to Negative (-) Battery Terminal with remaining Hex Bolt, Flat Washer, Lockwasher and Hex Nut (Fig. 3). Tighten securely.



5. Install Battery using: two Int./Ext. Lockwashers, two Wing Nuts (shown full size below) and

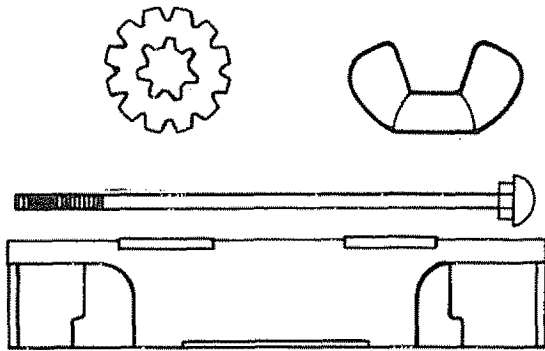

two Battery Bolts and one Terminal Guard found in Bag of Parts.

- a. Using the square hole on one side of the Battery Support (Fig. 4) insert one Battery Bolt, head of Bolt down. Fasten the Battery Bolt to the Terminal Guard using Int./Ext. Lockwasher and Wing Nut as shown in Fig. 4.
- b. Assemble the remaining Battery Bolt to other side of Battery Support and fasten Terminal Guard to it with remaining Int./Ext. Lockwasher and Wing Nut. Tighten Wing Nuts securely by hand (Fig. 4).

NOTE: USE TERMINAL ACCESS DOORS (FIG. 4) FOR:

1. Inspection for secure connections (tighten hardware).
2. Inspection for corrosion.
3. Testing battery.
4. Jumping (if required).
5. Charging (if required).

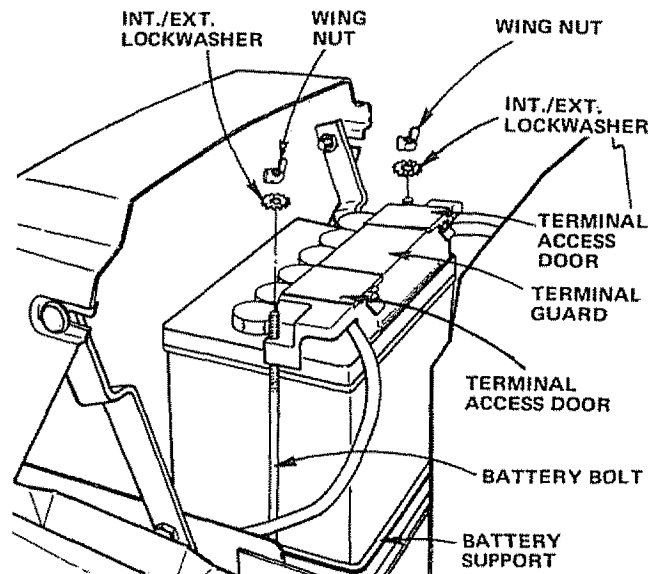

FIGURE 4

WHEN NOT IN USE, KEEP TERMINAL ACCESS DOORS CLOSED.



DO NOT START ENGINE UNTIL MOWER SUSPENSION BRACKET HAS BEEN RELEASED. SEE MOWER AND DRIVE BELT INSTALLATION, PAGE 8.

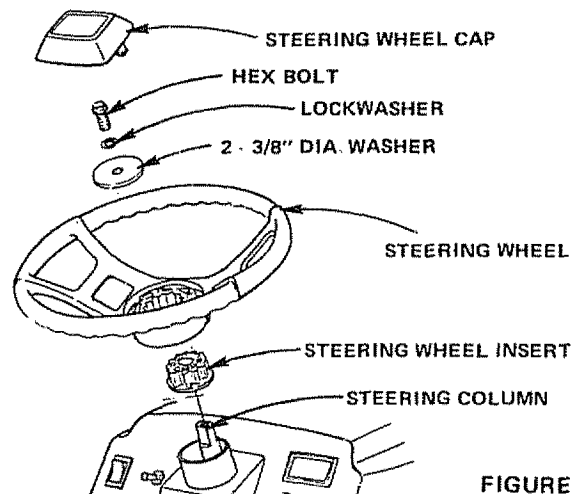

FIGURE 5

6. Remove plastic on Tractor Hood.

7. Close Hood.

8. Install Steering Wheel.

NOTE: POSITION FRONT WHEELS FORWARD

- a. Remove Hex Bolt, Lockwasher and 2 - 3/8" Dia. Washer from Steering Column (Fig. 5).
- b. Position Steering Wheel over Steering Wheel Insert.
- c. Secure Steering Wheel to Steering Column using Hex Bolt, Lockwasher and 2 - 3/8" Dia. Washer (Fig 5).
- d. Snap Steering Wheel Cap in place on Steering Wheel. Steering Wheel Cap found in Bag of Parts.

9. Install Seat.

- a. Remove cardboard from Seat Pan.
- b. Place Seat on Seat Pan. Screw Adjustment Bolts, Lockwashers and Flat Washers into Seat (Fig. 6). Adjustment Bolts, Lockwashers and Flat Washers found in Bag of Parts. Tighten finger tight.
- c. Place Seat in operating position. Sit on the Seat and press Clutch-Brake Pedal all the way down. If operating position is not comfortable, adjust Seat.
- d. Raise Seat. Use 9/16" wrench to loosen Adjustment Bolts (Fig. 6). When adjusted for comfortable operation, tighten Adjustment Bolts securely.

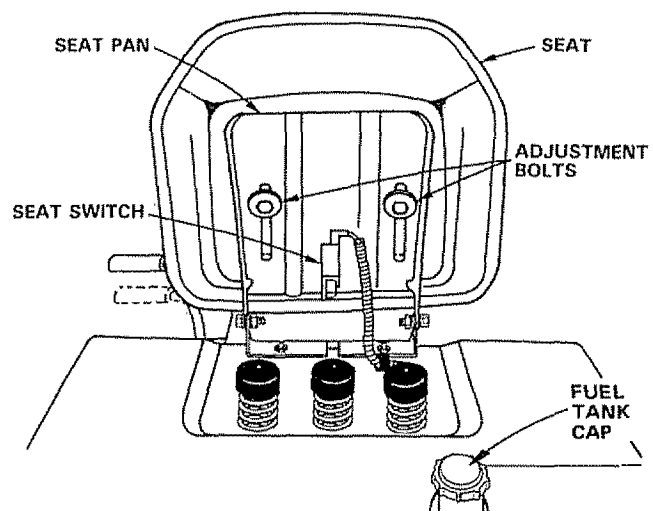

FIGURE 6

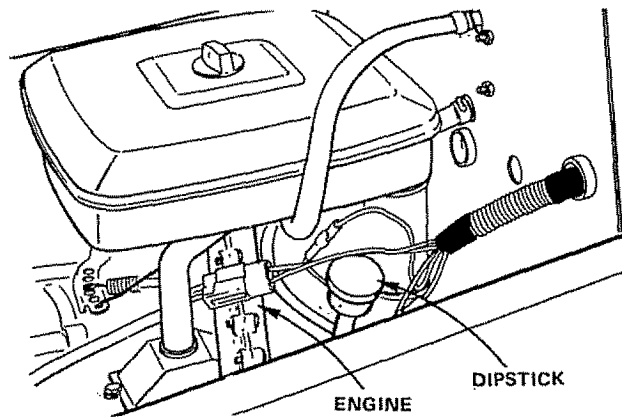

FIGURE 7

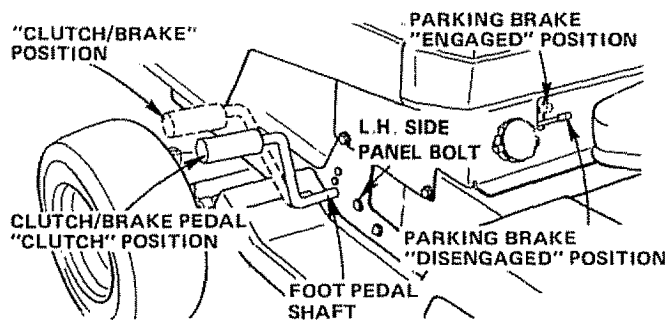

FIGURE 8

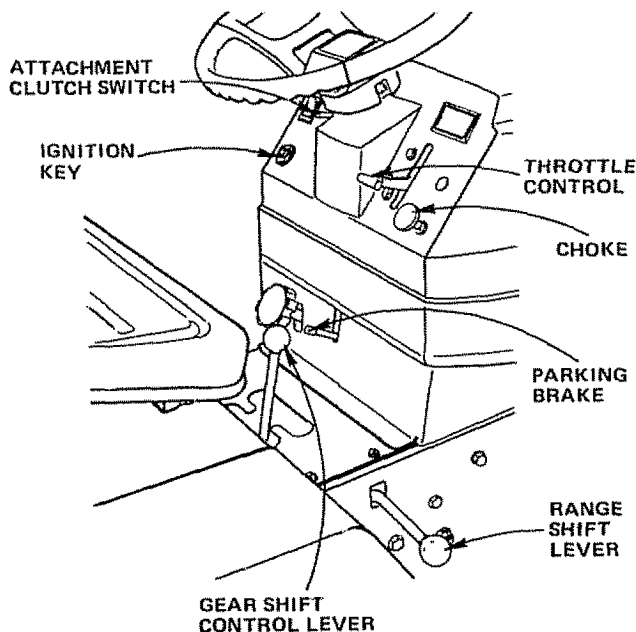

FIGURE 9

INITIAL SERVICE

1. This engine has been shipped filled with oil. Check Engine Oil Level with Tractor on level ground. Wipe Dipstick (Fig. 7) clean, screw it in tight for a few seconds, remove and read Oil Level. If necessary, add Oil until "FULL" mark is reached.

NOTE: ENGINE IS SHIPPED WITH SUMMER WEIGHT OIL

RECOMMENDED SAE VISCOSITY GRADES

TEMPERATURE RANGE EXPECTED BEFORE NEXT OIL CHANGE. ALL OILS MUST MEET A.P.I. SERVICE CLASSIFICATION SD, SE, OR SF.

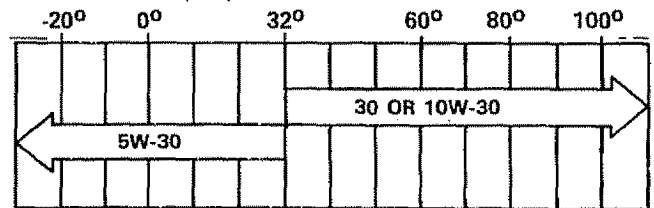

TO AVOID DAMAGE TO THE STARTING SYSTEM, USE SAE 5W30 OIL WHEN THE TEMPERATURE FALLS BELOW 32°.

Capacity is 1 - 1/2 quarts, NOTE: DO NOT OVERFILL. Dipstick assembly must be securely tightened into tube at all times when engine is operating.

2. Fill Fuel Tank (Fig. 6). Use fresh, clean, regular unleaded automotive gasoline. (Use of leaded gasoline will increase carbon and lead oxide deposits and reduce valve life). Capacity is 3 - 1/2 gallons.



FILL TO BOTTOM OF GAS TANK FILLER NECK. DO NOT OVERFILL. WIPE OFF ANY SPILLED OIL OR FUEL. DO NOT STORE, SPILL OR USE GASOLINE NEAR AN OPEN FLAME.

3. Reduce Tire pressure to 14 PSI in front and 10 PSI in rear Tires. (Tires were overinflated for shipping purposes).
4. Remove band from Mower Suspension Bracket (Fig. 11).

STARTING THE ENGINE



LEARN TO START, STOP AND REVERSE YOUR TRACTOR IN A LARGE, OPEN AREA.

NOTE: THIS TRACTOR IS EQUIPPED WITH INTERLOCK SWITCHES TO PREVENT STARTING OF THE TRACTOR ENGINE WHILE THE ATTACHMENT CLUTCH OR THE TRACTOR CLUTCH IS ENGAGED.



IMMEDIATELY REPLACE SWITCHES THAT ARE NOT IN PROPER WORKING ORDER. DO NOT ATTEMPT TO DEFEAT THE PURPOSE OF THESE SWITCHES.

1. Place Attachment Clutch Switch in "DISENGAGED" position (Fig. 9).
2. Push Clutch-Brake Pedal fully into brake position (Fig. 8).
3. Place Gear Shift Control Lever in "N" neutral, start position; and Range Shift Lever in "N" neutral position (Fig. 9).

4. Pull Choke out (Fig. 9).
5. Move Throttle Control to middle position (Fig. 9).
6. Turn Ignition Key to "START" position until Engine starts (Fig. 9). NOTE: DO NOT RUN STARTER CONTINUOUSLY FOR MORE THAN FIFTEEN SECONDS PER MINUTE. If engine does not start after several attempts, move Throttle Control to "F" (fast) position, wait a few minutes and try again.
The first time you start the engine, it will take extra cranking time to move fuel from tank to the engine.
NOTE: ALLOW ENGINE TO WARM UP FOR A FEW MINUTES BEFORE ENGAGING CLUTCH OF TRACTOR OR ATTACHMENT.
7. When restarting a warm engine, move Throttle Control midway between "S" (slow) and "F" (fast) position. Choke may not have to be used.

OPERATION



BEFORE DRIVING THE TRACTOR, INSTALL MOWER OR REMOVE MOWER SUSPENSION BRACKET.



CAUTION
TO AVOID INJURY

1. Read owners manual.
2. Know location and function of all controls.
3. Keep guards, safety shields and switches in place and working.
4. Remove objects that can be thrown by blades.
5. Do not mow when children and others are around.
6. Never carry children or passengers.
7. Always look behind machine before backing.
8. Do not mow where machine can tip or slip.
9. If machine stops going uphill, stop blade and back slowly down.
10. Be sure blades and engine have stopped before placing hands or feet near the blades.
11. Remove key when leaving machine.

TRACTOR OPERATION

NOTE: THIS TRACTOR IS EQUIPPED WITH AN OPERATOR PRESENCE SENSING SWITCH. ANY ATTEMPT BY THE OPERATOR TO LEAVE THE SEAT WITH THE ENGINE RUNNING AND THE ATTACHMENT CLUTCH ENGAGED WILL SHUT-OFF THE ENGINE.

1. With engine running and warm, place Throttle Control midway between "S" (slow) and "F" (fast) position.
2. Push Clutch-Brake Pedal down firmly (Fig. 8). Move Gear Shift Control Lever to desired gear and Range Shift Lever to "LO" (Low) position (Fig. 9).
3. Release Clutch-Brake Pedal SLOWLY to start forward or rearward movement.
4. If ground travel is too slow, move Throttle Control to "F" (fast) position or press Clutch-Brake Pedal and shift to a different gear.

NOTE: BRING TRACTOR TO COMPLETE STOP BEFORE SHIFTING GEARS. ALWAYS SELECT A GROUND TRAVEL SPEED THAT WILL SUIT THE TERRAIN AND THE ATTACHMENT BEING USED.



NEVER PLACE YOUR HANDS OR FEET IN OR UNDER ANY POWERED ATTACHMENT OR NEAR ANY MOVING PART WHILE TRACTOR OR ANY POWERED ATTACHMENT IS RUNNING.



DO NOT OPERATE THE MOWER WITHOUT THE DEFLECTOR SHIELD IN PLACE.

NOTE: A SPARK ARRESTER MUFFLER (PAGE 30) IS AVAILABLE AS AN ACCESSORY PART FOR YOUR TRACTOR. CHECK LEGAL REQUIREMENTS IN YOUR AREA.

STOPPING YOUR TRACTOR

1. Push Clutch-Brake Pedal into "BRAKE" position.
2. Place Parking Brake Lever in "ENGAGED" position and release pressure from Clutch-Brake. Pedal should remain in brake position. NOTE: MAKE SURE PARKING BRAKE WILL HOLD TRACTOR SECURE.
3. Move Shift Control Lever to "NEUTRAL" position.
4. Place Attachment Clutch Lever in "DISENGAGED" position.
5. Move Throttle Control to "S" (slow) position.
6. Turn Ignition Key to "OFF" position. Never use Choke to stop Engine.



REMOVE KEY WHEN LEAVING TRACTOR TO PREVENT UNAUTHORIZED USE.

TRANSPORTING YOUR TRACTOR

For pushing or towing your tractor, place Gear Shift Control Lever and Range Shift Lever to "N" neutral position (Fig. 9). NOTE: DO NOT TOW YOUR TRACTOR FASTER THAN SIX MILES PER HOUR.

TRACTOR OPERATION ON HILLS

1. Choose the lowest gear BEFORE starting up or down hills.



DO NOT DRIVE UP OR DOWN HILLS WITH SLOPES GREATER THAN 15°, AND DO NOT DRIVE ACROSS ANY SLOPE. REFER TO PAGE 47.

2. AVOID STOPPING OR SHIFTING ON HILLS.
 - a. If slowing is necessary, move Throttle Control Lever to middle position.



LEAVE ENOUGH ROOM WHEN STOPPING AND STARTING TO ALLOW SLIGHT TRACTOR ROLL DOWNHILL AS CLUTCH-BRAKE PEDAL MOVES THROUGH CLUTCH POSITION.

- b. If stopping is absolutely necessary, push Clutch-Brake Pedal quickly to brake position and engage Parking Brake.
- c. To restart your tractor, make sure tractor is in 1st gear and that you have allowed room to roll slightly downhill. Disengage Parking Brake and release Clutch-Brake Pedal SLOWLY to start tractor forward movement.

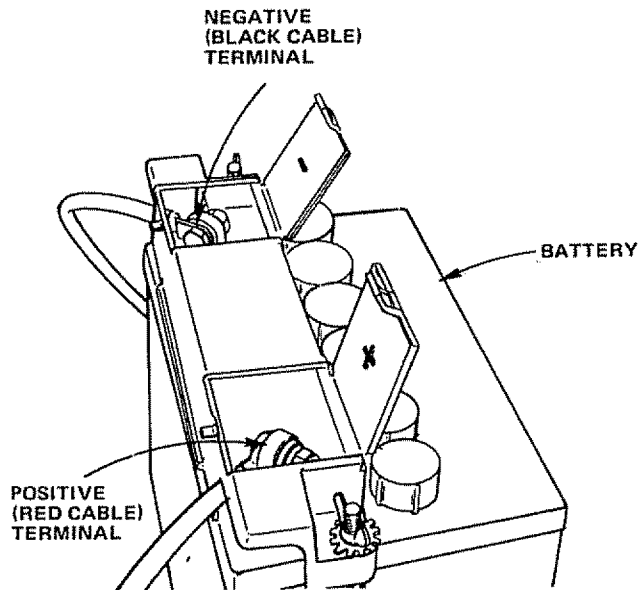

FIGURE 10

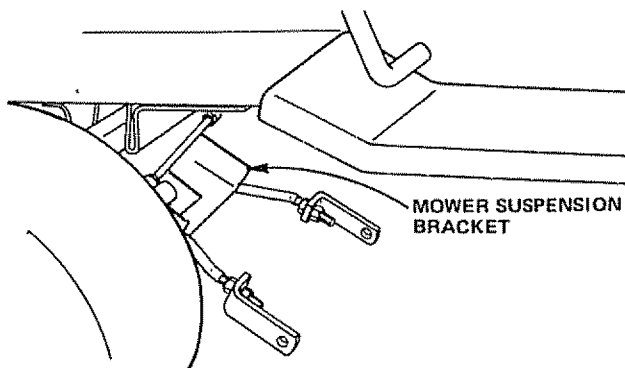

FIGURE 11

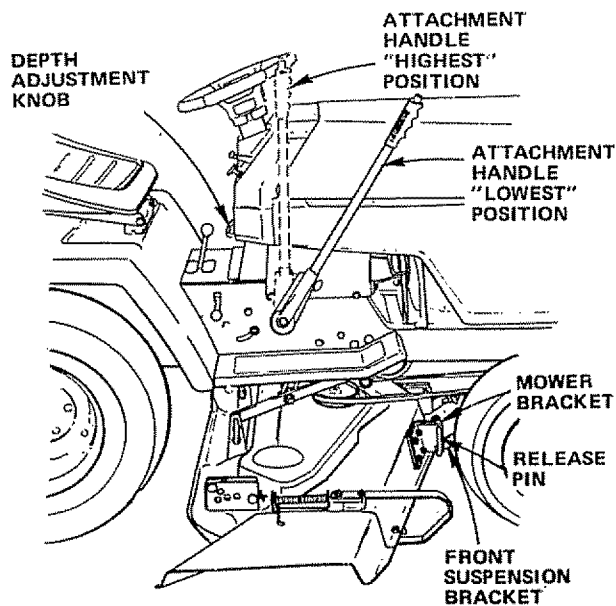

FIGURE 12

STARTING YOUR TRACTOR WITH A LOW BATTERY

If your Battery is too low to start the engine, it should be recharged. If "Jumper Cables" are used for emergency starting follow this procedure: NOTE: YOUR TRACTOR IS EQUIPPED WITH A 12 VOLT NEGATIVE GROUNDED SYSTEM, THE OTHER VEHICLE MUST ALSO BE A 12 VOLT NEGATIVE GROUNDED SYSTEM. NOTE: DO NOT USE TRACTOR TO START OTHER VEHICLES.



LEAD-ACID BATTERIES GENERATE EXPLOSIVE GASES. KEEP SPARKS, FLAME, AND SMOKING MATERIALS AWAY FROM BATTERIES. ALWAYS WEAR EYE PROTECTION AROUND BATTERIES.

1. Connect each end of the RED cable to the POSITIVE (+) terminals of each battery (taking care not to short against chassis) (Fig. 10).
2. Connect one end of the BLACK cable to the NEGATIVE (-) terminal of fully charged battery.
3. Connect the other end of the cable to the L.H. Side Panel Bolt (Fig. 8). NOTE: KEEP AWAY FROM GAS TANK AND BATTERY.
4. Disconnect cables in reverse order:
 - a. L.H. Side Panel Bolt (Fig. 8).
 - b. Negative terminal of fully charged battery.
 - c. Positive terminals.

MOWER AND DRIVE BELT INSTALLATION

Your tractor has been shipped with the Mower Suspension Bracket banded to the frame. Remove bands and lower Mower Suspension Bracket (Fig. 11).

MOWER INSTALLATION

1. Remove banding from Suspension Arms and Gauge Wheels. Set Gauge Wheels aside for later assembly.
2. Slide Mower under Tractor, Deflector to right hand side.
3. Slide Front Suspension Brackets into Mower Brackets. Retain with Release Pins (Fig. 12). Turn Depth Adjustment Knob counterclockwise (⤴) until it stops. Push Attachment Handle forward to lower mower to ground.
4. Slide Studs through Lift Links on both sides of Tractor (Fig. 12A). Retain with Washers and Retainer Springs found in Bag of Parts.
5. Place the Suspension Arms on Brackets on both sides of Frame (Fig. 12A). Retain with Washers and Retainer Springs found in Bag of Parts.
6. Turn Depth Adjustment Knob (Fig. 12) clockwise (⤵) to remove slack from Mower Suspension.
7. Roll Drive Belt over Primary Mandrel (Fig. 13).
8. Insert Gauge Wheel Bar into Bracket. Retain with Clevis Pin and Retainer Spring (Fig. 14).

DRIVE BELT INSTALLATION

1. Remove Hood and Grill (see page 24).
2. Place Mower Drive Belt over Clutch Pulley and under Idler Pulley and Tension Pulley (Fig. 15). NOTE: PULL LEVER UP TO SWING TENSION PULLEY FOR BELT CLEARANCE. Make sure narrow "V" side of Belt is engaged with each Pulley.
3. Pull Mower Drive Belt over Front Mower Suspension Bracket (Fig. 16).
4. Replace Hood and Grill.

BELT ADJUSTMENT

1. Lower mower.
2. If dimension "A" on Idler Bracket Assembly measures 1/4" or less, Mower Drive Belt must be adjusted (Fig. 15 - Inset).
3. Disengage Attachment Clutch Switch.
4. Remove Bolt, Washer, Washer (2), Lockwasher and Nut from Idler Pulley (Fig. 15 - Inset) (original position).
5. Place V-Belt and Idler Pulley in "NEW" Pulley position (Fig. 15 - Inset). Replace Bolt, Washer, Washer (2), Lockwasher and Nut. Tighten securely.
6. Check V-Belt for proper installation on all Pulley Grooves

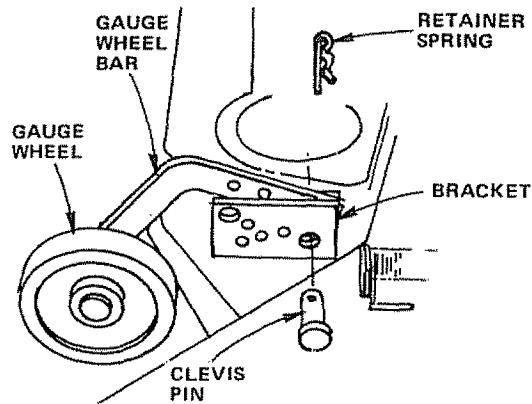

FIGURE 14

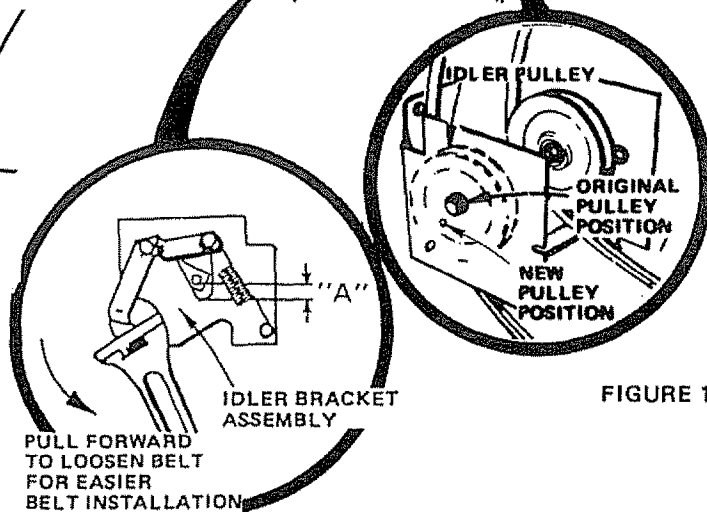
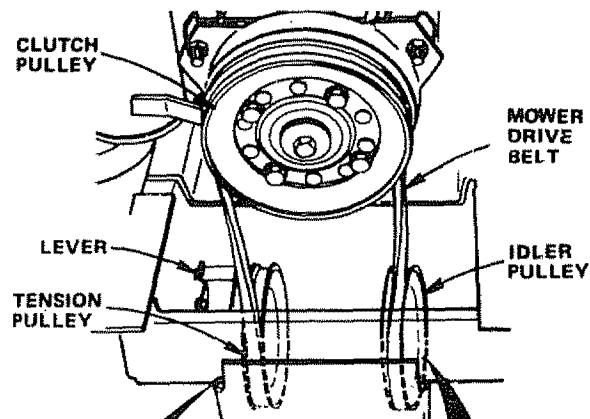

FIGURE 15

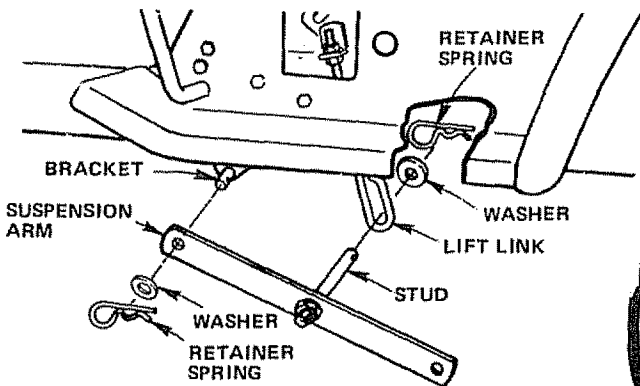

FIGURE 12A

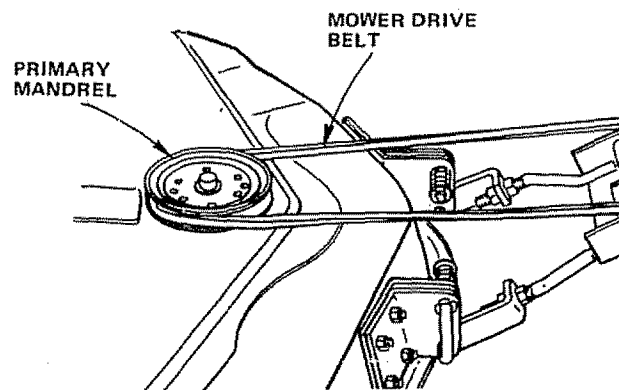

FIGURE 13

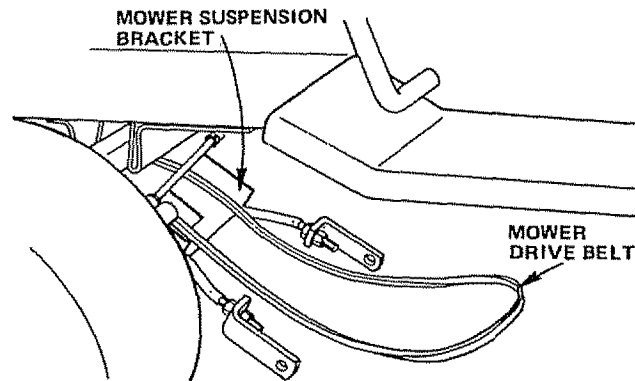

FIGURE 16

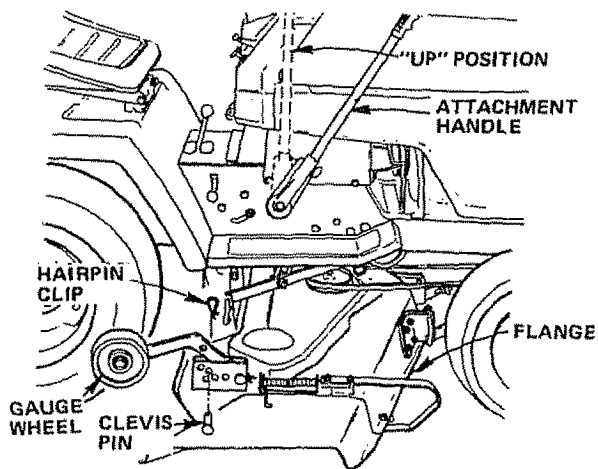

FIGURE 17

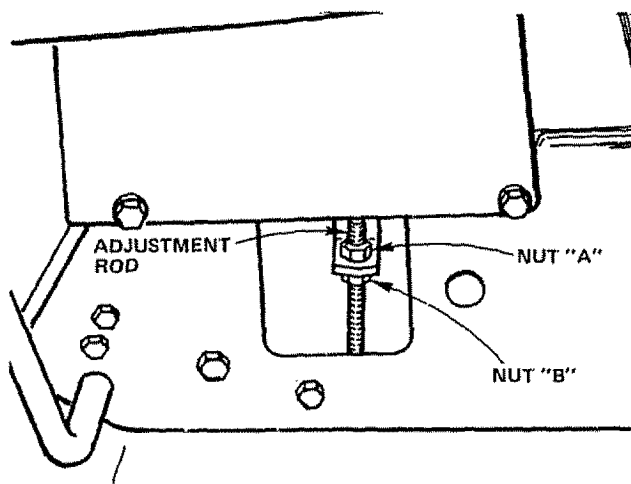

FIGURE 18

MOWER ADJUSTMENT

Adjust the mower while tractor is parked on level ground or driveway. NOTE: MOWER SHOULD BE IN LOWEST CUTTING POSITION. Make sure tire pressures are 14 PSI in front; 10 PSI in rear.

SIDE TO SIDE ADJUSTMENT

1. Use a ruler to make sure Flanges at rear of mower deck are the same height from the ground on each side (Fig. 19).
2. If adjustment is required, snap out Access Cover on L.H. side of tractor above Foot Rest (Fig. 18).
3. Move Attachment Handle to full "UP" position (Fig. 17).
4. To lower right side of mower, loosen Nut "B" and screw Nut "A" down on Adjustment Rod.
5. To lower left side of mower, loosen Nut "B" and screw Nut "A" up on Adjustment Rod.
6. Adjust until both rear mower flanges are the same height above the ground, Tighten Nuts "A" and "B" securely. Snap Access Cover in place.

FRONT TO REAR ADJUSTMENT

Move Attachment Handle to full "UP" position (Fig. 17). After leveling side to side, measure R.H. Flanges at FRONT AND REAR OF MOWER. The R.H. Front Flange should measure 3/4" lower than the R.H. Rear Flange (Fig. 19). If adjustment is required, follow procedure below.

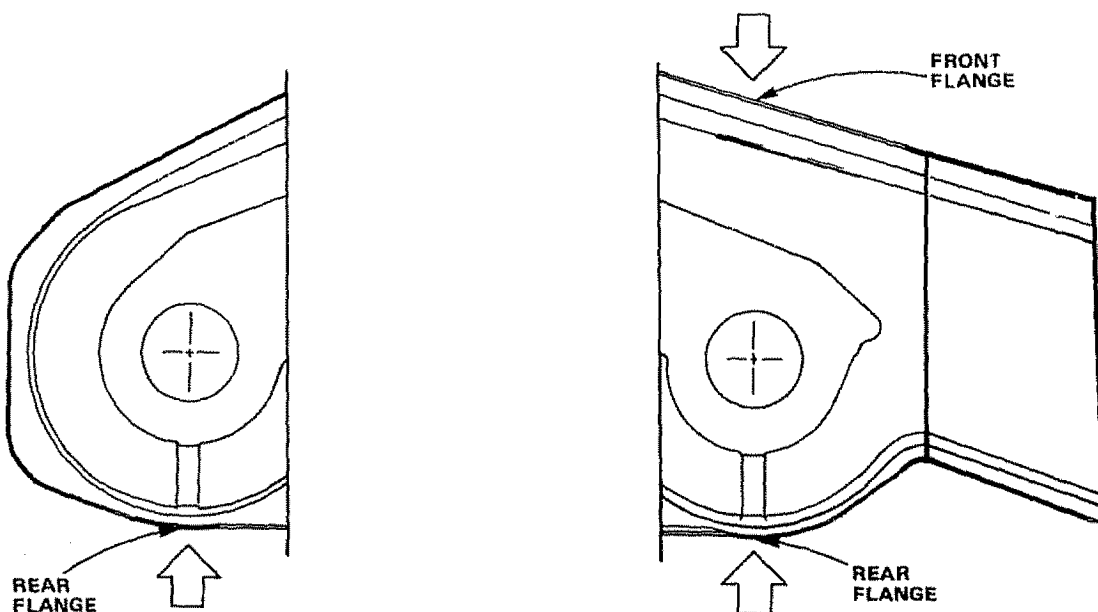

FIGURE 19

1. TO RAISE FRONT OF MOWER
Loosen Nuts "D". Screw Nuts "C" up onto Suspension Arms (Fig. 20). NOTE: SCREW NUTS "C" ON BOTH SUSPENSION ARMS THE SAME NUMBER OF TURNS SO MOWER WILL REMAIN LEVEL. Tighten Nuts "D" securely.
2. TO LOWER FRONT OF MOWER
Loosen Nuts "C". Screw Nuts "D" down Suspension Arms. NOTE: SCREW NUTS "D" THE SAME NUMBER OF TURNS SO MOWER WILL REMAIN LEVEL. Tighten Nuts "C" securely.
3. With mower deck at desired height, set Gauge Wheels (Fig. 17) to lowest position without touching the ground.

Use Adjustment Handle to set mower at the approximate cutting height you need. Use Clevis Pins (Fig. 17) to set gauge wheels at lowest point without touching the ground.

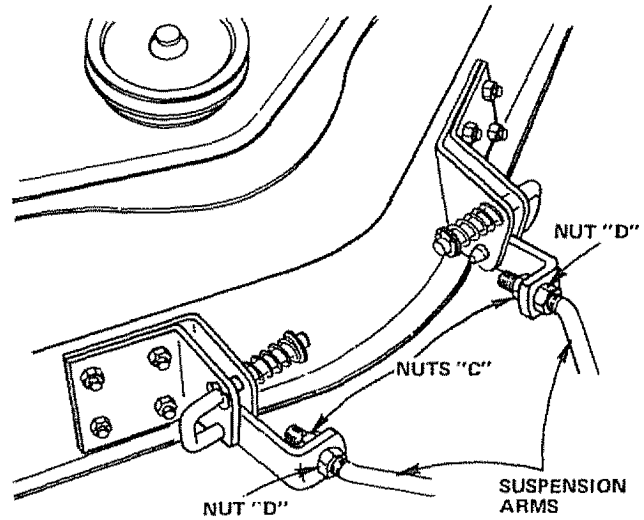

FIGURE 20

MOWER OPERATION

When ready to mow, lower Attachment Handle (Fig. 21) to preferred mower height. Select a gear that allows mowing at full throttle. This allows the mower blades to lift and cut the grass efficiently.

MOWER ENGAGEMENT

Pull Clutch Switch (Fig. 22) out and up to engage clutch. There will be an engine hesitation as the clutch engages. NOTE: THIS TRACTOR IS EQUIPPED WITH AN OPERATOR PRESENCE SENSING SWITCH. ANY ATTEMPT BY THE OPERATOR TO LEAVE THE SEAT WITH THE ENGINE RUNNING AND THE ATTACHMENT CLUTCH ENGAGED WILL SHUT-OFF THE ENGINE.

DEPTH ADJUSTMENT

Fine adjustment of mower height is controlled by the Depth Adjustment Knob. Turn clockwise (↻) to raise mower. Turn counterclockwise (↺) to lower mower (Fig. 22).

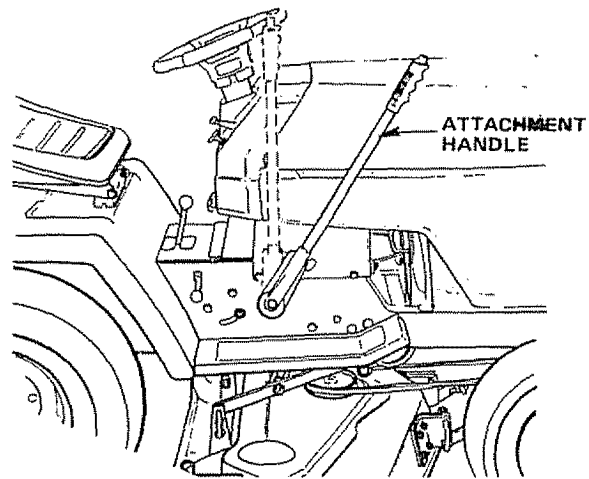

FIGURE 21

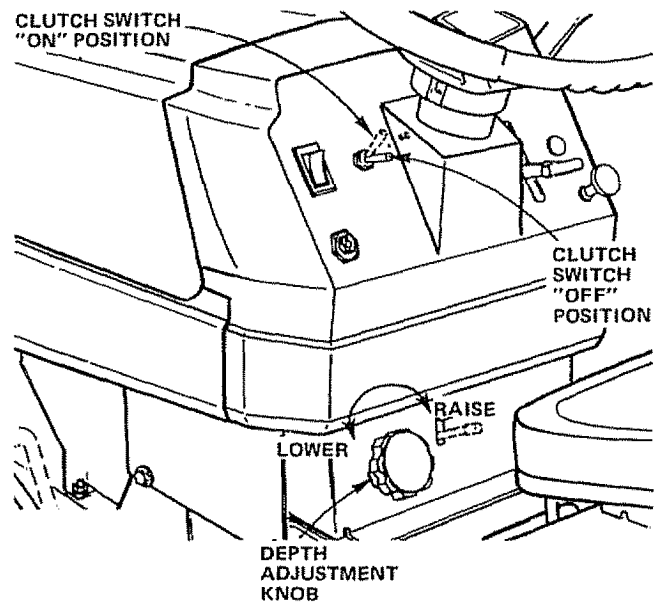

FIGURE 22

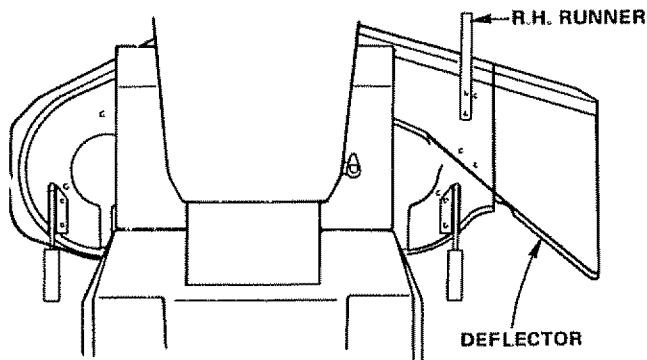

FIGURE 23

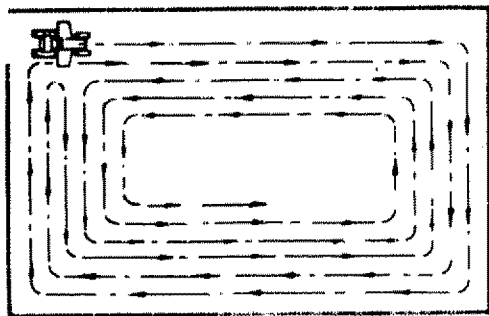

FIGURE 24

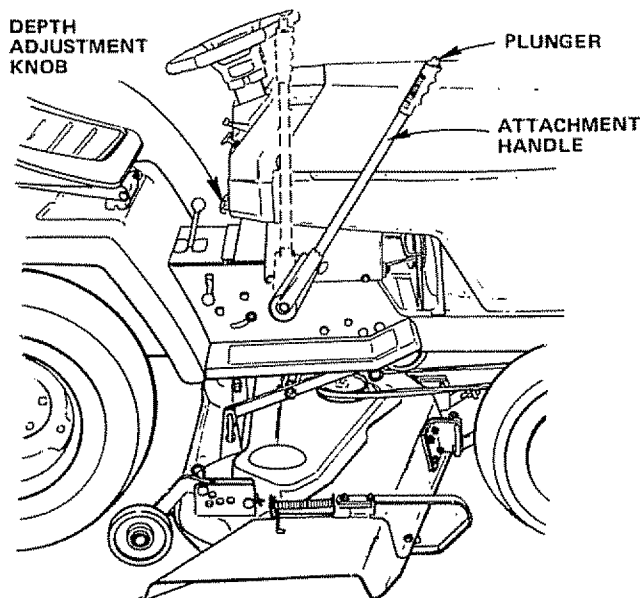

FIGURE 25

Use the Runner on the right hand side as a guide; the blade cuts approximately an inch outside the runner.



NEVER REMOVE DEFLECTOR. KEEP HANDS AND FEET FROM UNDER MOWER.



CAUTION TO AVOID INJURY

1. Read owners manual.
2. Know location and function of all controls.
3. Keep guards, safety shields and switches in place and working.
4. Remove objects that can be thrown by blades.
5. Do not mow when children and others are around.
6. Never carry children or passengers.
7. Always look behind machine before backing.
8. Do not mow where machine can tip or slip.
9. If machine stops going uphill, stop blade and back slowly down.
10. Be sure blades and engine have stopped before placing hands or feet near the blades.
11. Remove key when leaving machine.



NEVER ENGAGE ("ENGAGE" POSITION) MOWER EXCEPT WHEN SITTING ON TRACTOR SEAT.

TIRE CHAINS CANNOT BE USED WITH THE MOWER HOUSING ATTACHED.



READ THE "RULES FOR SAFE OPERATION" CAREFULLY BEFORE OPERATING YOUR MOWER. REFER TO PAGE 3.

12. Use Attachment Handle to lower mower into cutting position. Start mowing at slow speed and increase ground speed by increasing throttle as conditions will permit. Average cutting height is approximately 2 - 1/2 to 2 - 3/4 inches. Height of cut can be adjusted by means of the Depth Adjustment Knob (Fig. 25). Turn Depth Adjustment Knob (clockwise (↻) or counterclockwise (↺) to match pre-selected Lift Control Lever mowing height.
13. Drive so that clippings are discharged onto the area that has been cut. Have the cut area to the right of the machine. This will result in a more even distribution of clippings and more uniform cutting. When mowing large areas (Fig. 24), start by turning to the right so that the clippings will be discharged away from shrubs, fences, driveways, etc. After two or three rounds, mow in the opposite direction making left hand turns until finished. If grass is extremely tall, it should be mowed twice. The first time cut relatively high. The second time to the desired height. The left hand side of mower should be used for trimming.

MOWER MAINTENANCE INSTRUCTIONS



BEFORE MAKING ANY INSPECTION, ADJUSTMENT OR REPAIR: PUSH TRACTOR CLUTCH-BRAKE PEDAL COMPLETELY INTO BRAKE POSITION. MOVE SHIFT CONTROL LEVER TO NEUTRAL POSITION. PLACE PARKING BRAKE IN "ENGAGED" POSITION. TURN OFF MOWER CLUTCH SWITCH (FIG. 26).



SHUT OFF THE ENGINE. MAKE ABSOLUTELY SURE THE BLADES AND ALL MOVING PARTS HAVE COMPLETELY STOPPED. REMOVE THE IGNITION KEY. DISCONNECT THE SPARK PLUG WIRES FROM THE SPARK PLUGS AND KEEP WIRES AWAY FROM THE PLUGS TO PREVENT INJURY FROM ACCIDENTAL STARTING.

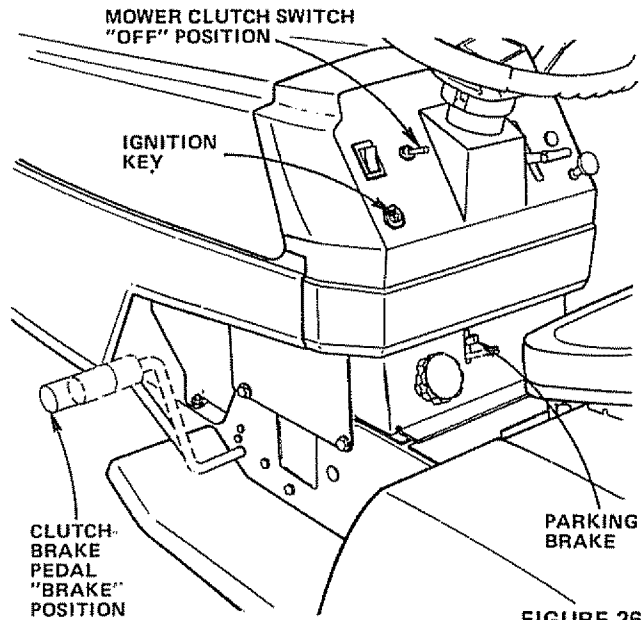

FIGURE 26

BLADE CARE

For best results mower blades must be kept sharp. The blades can be sharpened with a few strokes of a file or on a grinding wheel. We suggest they be sharpened after every 15 hours of mowing. Do not attempt to sharpen while on mower.

1. When grinding, care should be taken to maintain blade balance and the blade should be checked for proper balance before reinstallation on mower. Unbalanced or bent blade will cause excessive vibration when running and eventual damage to mower or engine. Replace bent or damaged blades.

To check Blade balance, drive a nail into a beam or wall. Leave about one inch of the straight nail exposed. Place Center Hole of clean Blade over the head of the nail (Fig. 27A). NOTE: CENTER HOLE OF BLADE ON NAIL. IF BLADE IS PROPERLY BALANCED, BLADE SHOULD REMAIN IN POSITION SHOWN IN FIG. 27A. IF EITHER END OF THE BLADE MOVES DOWNWARD, BLADE IS NOT BALANCED AND MUST BE REPLACED.

2. To ensure satisfactory operation, it is recommended that before the start of each mowing season, the old blades be discarded and replaced with new blades. Mower blades can be purchased at any Sears Service Center/Departments and most Sears Retail Stores.

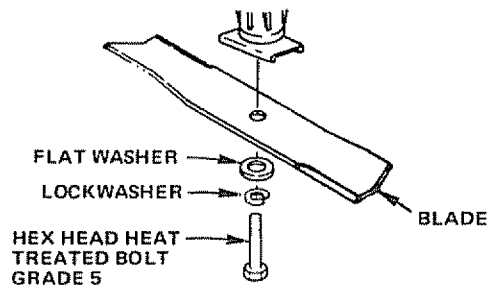

FIGURE 27

BLADE REPLACEMENT

It is not necessary to remove mower from tractor for blade replacement. By moving Lift Control Lever to up (Rear) position will permit access to blades.

1. Remove the Hex Head Bolt, Lockwasher and Flat Washer (Fig. 27).
2. Install new blade with SHARP EDGE DOWN and secure with Flat Washer, Lockwasher and Hex Head Bolt. TIGHTEN SECURELY.



ALWAYS USE GRADE 5 HEAT TREATED BOLTS TO ATTACH BLADES. CHECK BOLTS IN BLADES OCCASIONALLY TO MAKE SURE BOLTS ARE TIGHT. TORQUE BOLTS 30 - 35 FT. LBS.

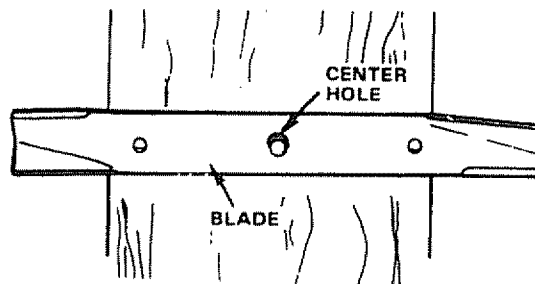
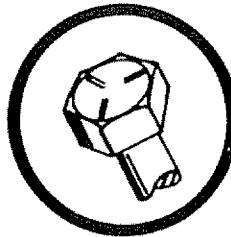

FIGURE 27A



A GRADE 5 HEAT TREATED BOLT CAN BE IDENTIFIED BY THREE LINES INDICATED ON THE BOLT HEAD AS SHOWN AT LEFT.

DAILY MAINTENANCE

Make sure all nuts on bolts are tight, cotter pins and retainer springs are secure. Keep blades sharp. Observe all safety precautions. Keep mower well lubricated.

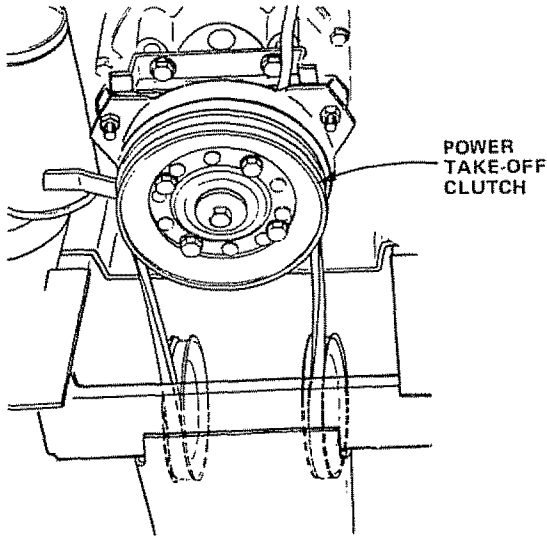

FIGURE 29

CLEANING MOWER



DISCONNECT SPARK PLUG WIRES TO PREVENT ACCIDENTAL STARTING BEFORE CLEANING.

Water pressure from a garden hose will remove fresh clippings from underside of mower. Clean mower after each mowing.

POWER TAKE - OFF CLUTCH

The Power Take-Off Clutch (Fig 29) should provide years of service. The Clutch incorporates a built in brake that stops the Pulley almost immediately. Eventually, the internal brake will wear so the mower blades will not stop as recommended. Adjustment should be made by a Sears Service Technician.

OUTER BLADES DRIVE BELT (CENTER TO OUTER MANDRELS)

BELT ROUTING DECAL UNDER MOWER DECK COVER

1. Remove Mower from Tractor (see below).
2. Remove Top Cover Self Tapping Screws, and Nut from Idler Arm Bolt.
3. Roll Belt over the top of the R. H. Mandrel.
4. Pull Belt off all other Mandrels.
5. Remove any dirt and grass which may have accumulated around Mandrels and Idler Arm.
6. Check Deck Idler Arm Assembly and Flat Idler to see that they rotate freely (Fig. 30).
7. Be sure spring is hooked in Deck Idler Arm Assembly and on bolt in Mower Housing (Fig. 30).
8. Install new Belt in groove of L.H. Mandrel Sheave, lower groove of Center Mandrel Sheave and around Flat Idler as shown (Fig. 30).
9. From a position at discharge end of mower, roll Belt into groove of R.H. Mandrel Sheave (Fig. 30).
10. Rotate Center Mandrel Sheave by hand to make sure Belt is in grooves properly

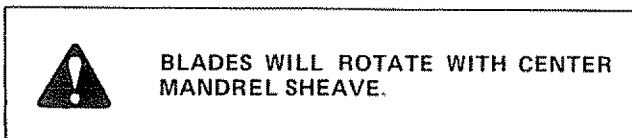

11. Reassemble Top Cover to Deck. Tighten all Screws securely.
12. Install Mower to tractor (see page 8).

REMOVING MOWER FROM TRACTOR

1. Lower Mower.
2. Pull the four (4) Release Pins out of Suspension Brackets (Fig. 31).
3. Pull back on Attachment Lift Handle and lock into place.
4. Slide Mower forward and remove Belt from Primary Mandrel.
5. Raise Attachment Lift Handle. Slide Mower out from under tractor.

NOTE: IF AN ATTACHMENT OTHER THAN THE MOWER DECK IS TO BE MOUNTED ON THE TRACTOR, THE L.H. AND R.H. SUSPENSION ARMS (FIG. 31) SHOULD BE REMOVED FROM TRACTOR.

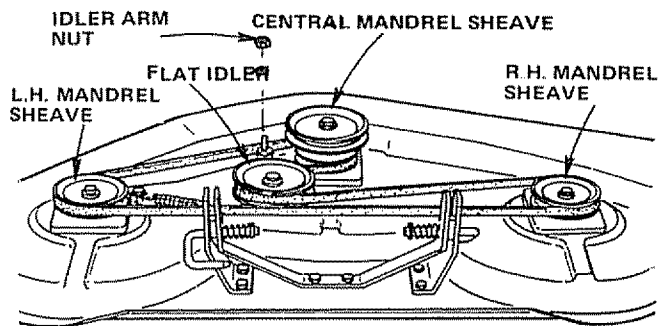

FIGURE 30

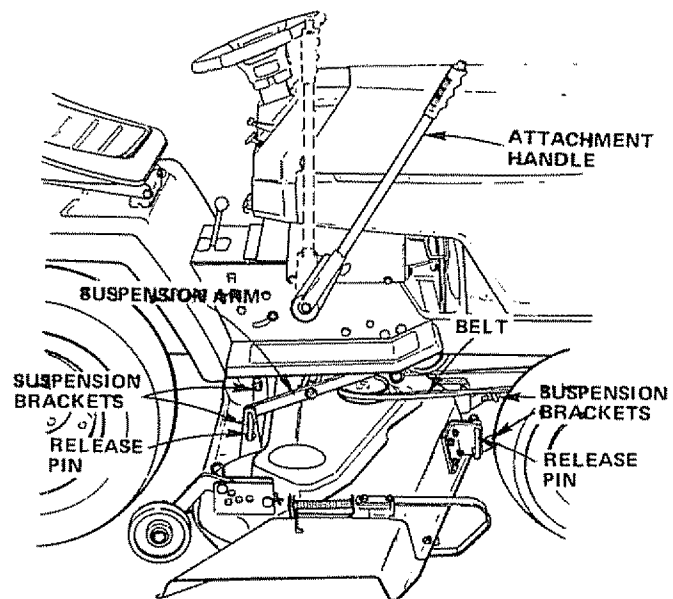

FIGURE 31

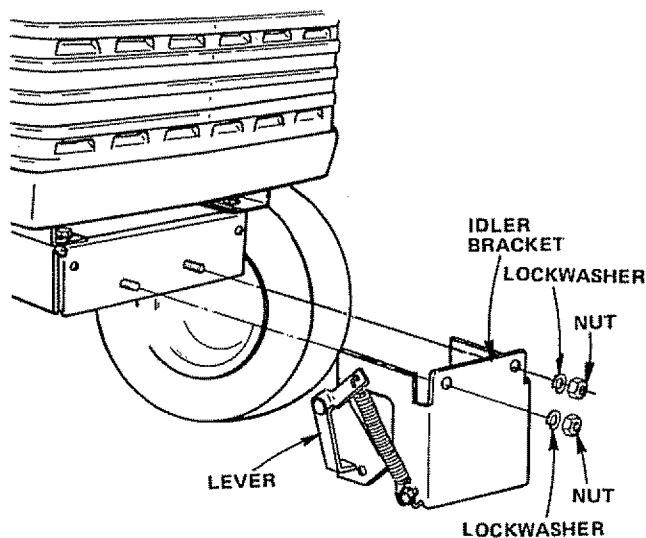

FIGURE 32

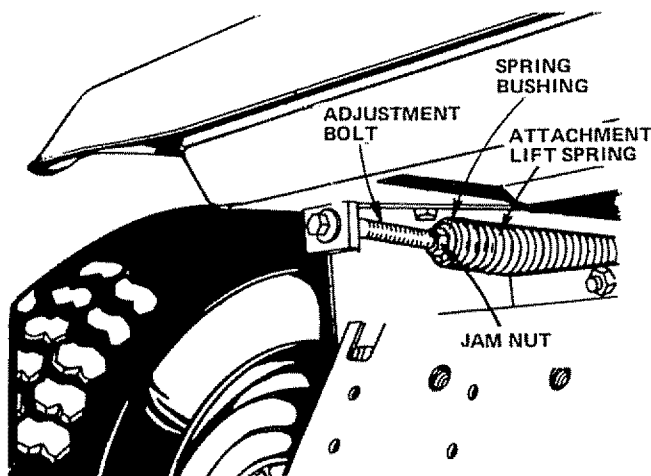

FIGURE 33

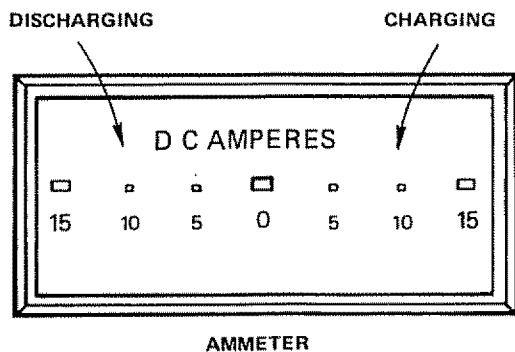

FIGURE 34

NOTE: WHEN OPERATING TRACTOR WITHOUT MOWER; REMOVE IDLER BRACKET FROM FRONT OF TRACTOR.

1. Pull Belt up through Idler Bracket and out of tractor. Use Lever to swing Tension Pulley for Belt removal.
2. Remove Lockwashers and Nuts from Idler Bracket (Fig. 32).

STORAGE

Remove mower from tractor for winter storage. When mower is to be stored for a period of time, clean it thoroughly, remove all dirt, grease, leaves, etc. Give blades and underside of housing a good coat of grease or rust preventative. Store in a clean dry area.

ATTACHMENT LIFT ADJUSTMENT

Due to different weights of Attachments, the Attachment Lift Spring may require adjustment. The Adjustment Bolt is located on rear of tractor top left side (Fig. 33).

1. Holding Spring Bushing with Wrench, loosen Jam Nut.
2. Turn Adjustment Bolt clockwise (↻) to extend Spring and reduce lift effort (for heavier Attachments).
3. Turn Adjustment Bolt counterclockwise (↺) (for lighter Attachments).
4. Retighten Jam Nut against Spring Bushing.

NOTE: DO NOT ADJUST FOR MAXIMUM SPRING TENSION WHEN USING LIGHT ATTACHMENTS SUCH AS A MOWER. ADJUST LIFT SPRING TO AID IN LIFTING ATTACHMENT - DON'T OVER POWER SPRING. WHEN REMOVING ATTACHMENT ALWAYS ADJUST WITH SPRING TENSION TO ITS LOWEST POSITION.

TRACTOR MAINTENANCE INSTRUCTIONS

To keep your tractor running better, longer; perform necessary service using the following Maintenance Schedule.

Each time you start your tractor, check your Ammeter (Fig. 34). The needle should move towards the + (charging) mark indicating the battery is being charged as you operate the tractor. The headlights will not show a discharge on the ammeter because they are not connected to the battery (they have their own electrical source, see page 26). If you have a lift motor connected it will show a discharge when being operated.



DISCONNECT SPARK PLUG WIRES TO PREVENT ACCIDENTAL STARTING BEFORE MAKING ANY INSPECTION, ADJUSTMENT OR REPAIR (EXCEPT CARBURETOR).

FIRST 2 HOURS

1. CHANGE ENGINE OIL

Changing Oil after the first two hours will help eliminate break-in residue which might be damaging to your Engine,

NOTE: BE CAREFUL NOT TO ALLOW DIRT TO ENTER THE ENGINE WHEN CHANGING OIL.

- a. Drain oil with Engine warm. Remove Hood and Grill (see page 24). Loosen Oil Drain Wing Nut. Catch oil in a suitable container. Tighten Oil Drain Wing Nut after all oil has been drained from Engine.
- b. Refill Engine Oil. (See chart, page 6). Refill capacity is 1 - 1/2 quarts. **NOTE: DO NOT OVERFILL.** Replace Dipstick.

DAILY OR EVERY 8 HOURS

1. CHECK ENGINE OIL LEVEL



DO NOT CHECK ENGINE OIL LEVEL WITH ENGINE RUNNING.

Several minutes after stopping Engine, check Engine Oil Level with Tractor on level ground. Wipe dipstick (Fig. 35) clean, screw it down tight for a few seconds, remove and read Oil Level. If necessary, add Oil until "FULL" mark is reached. (See chart, page 6). **NOTE: DO NOT OVERFILL.**

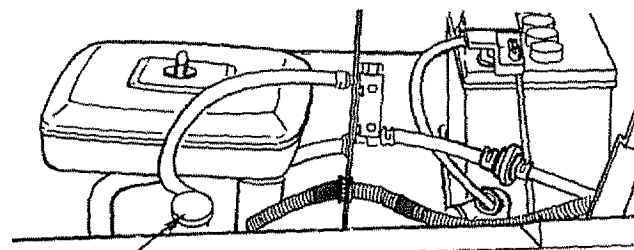

ENGINE OIL
DIPSTICK
AND FILL TUBE

L.H. SIDE

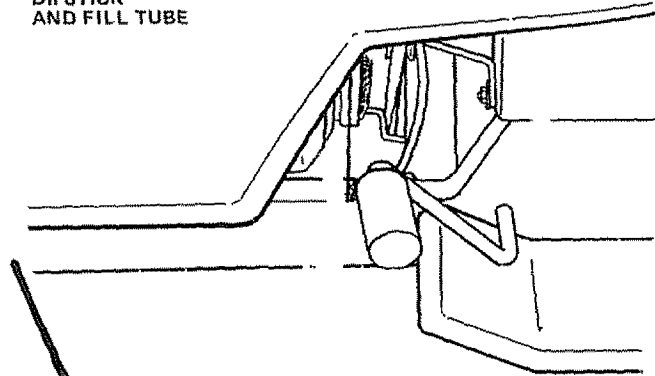
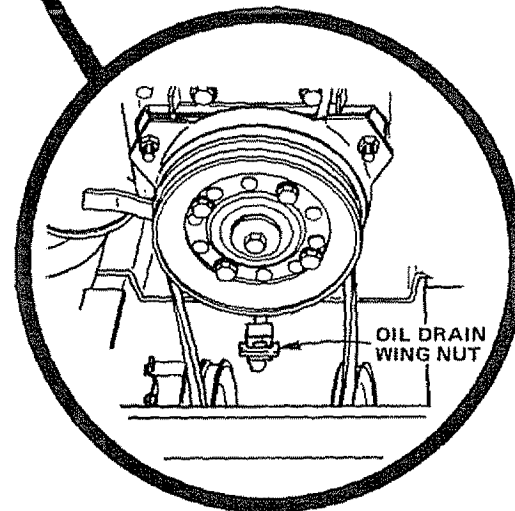

FIGURE 35



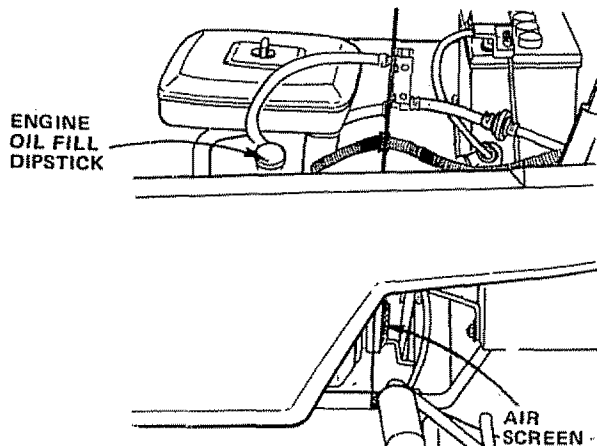

FIGURE 36

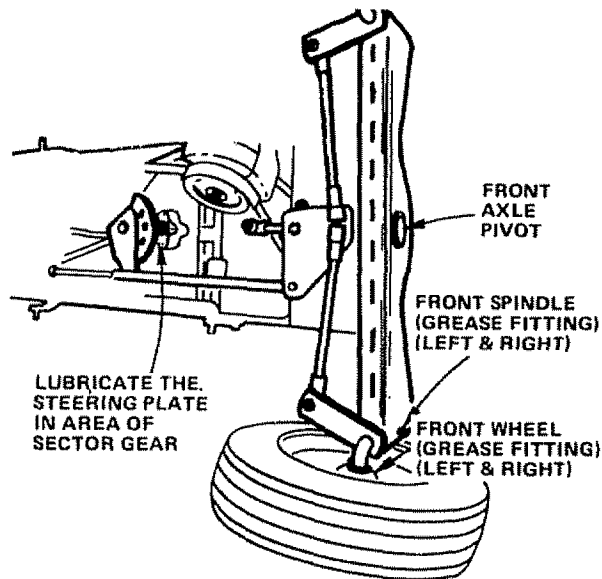

FIGURE 37

CUT-AWAY VIEW

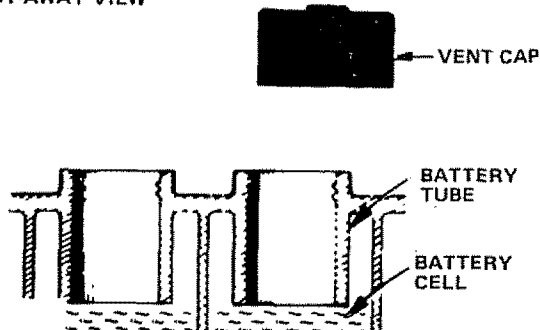

FIGURE 38

EVERY 25 HOURS

(EVERY 15 HOURS IF OPERATING IN VERY DUSTY CONDITIONS)

1. CLEAN AIR SCREEN

Air Screen (Fig. 36 and Fig. 40) must allow free-flow of air to prevent Engine damage from overheating. Clean with a wire brush, or compressed air to remove dirt, chaff, stubborn dried gum and fibers.

2. CLEAN FRONT GRILL

The front Grill (Fig. 2) must allow free flow of air to prevent engine damage from overheating.

- Brush off debris.

3. LUBRICATE STEERING AND FRONT WHEELS

There are four Grease Fittings on your Tractor (Fig. 37). Using a Grease Gun, give each Grease Fitting two shots of Extreme Pressure Lubricating Grease Amdex No. 1 or equivalent (available through your Sears Service Center). Sears Part No. 2557R.

4. OIL PIVOT POINTS

Place several drops of S.A.E. 30 Oil at points where parts move against each other, especially:

- Front Axle Pivot.
- Hood Hinges.
- Foot Pedal Shaft (both ends).
- Lift Shaft (both ends).
- Steering Plate.

SEE LUBRICATION CHART, PAGE 19.

5. CHECK BATTERY

- Electrolyte solution level in each Battery Cell should be even with bottoms of tubes in cells (Fig. 38). Add only distilled water if necessary. NOTE: DO NOT OVERFILL. DO NOT ADD ACID.
- Keep Battery and Terminals clean. Refer to step 8.
- Keep Battery Bolts tight.
- Keep Vent Caps tight and small vent holes in Caps open.
- Recharge at 6 amperes for 1 hour if necessary.

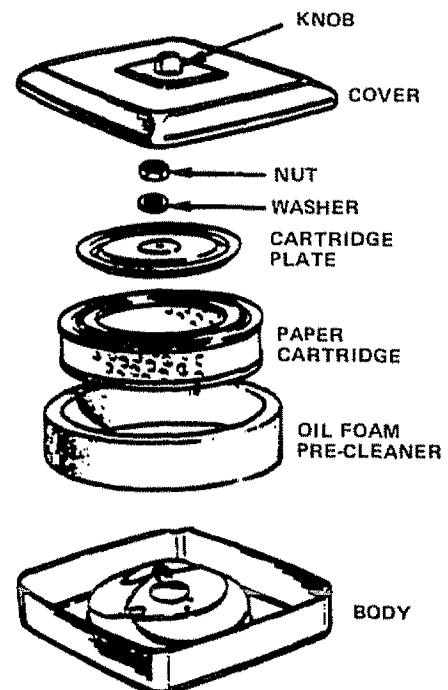
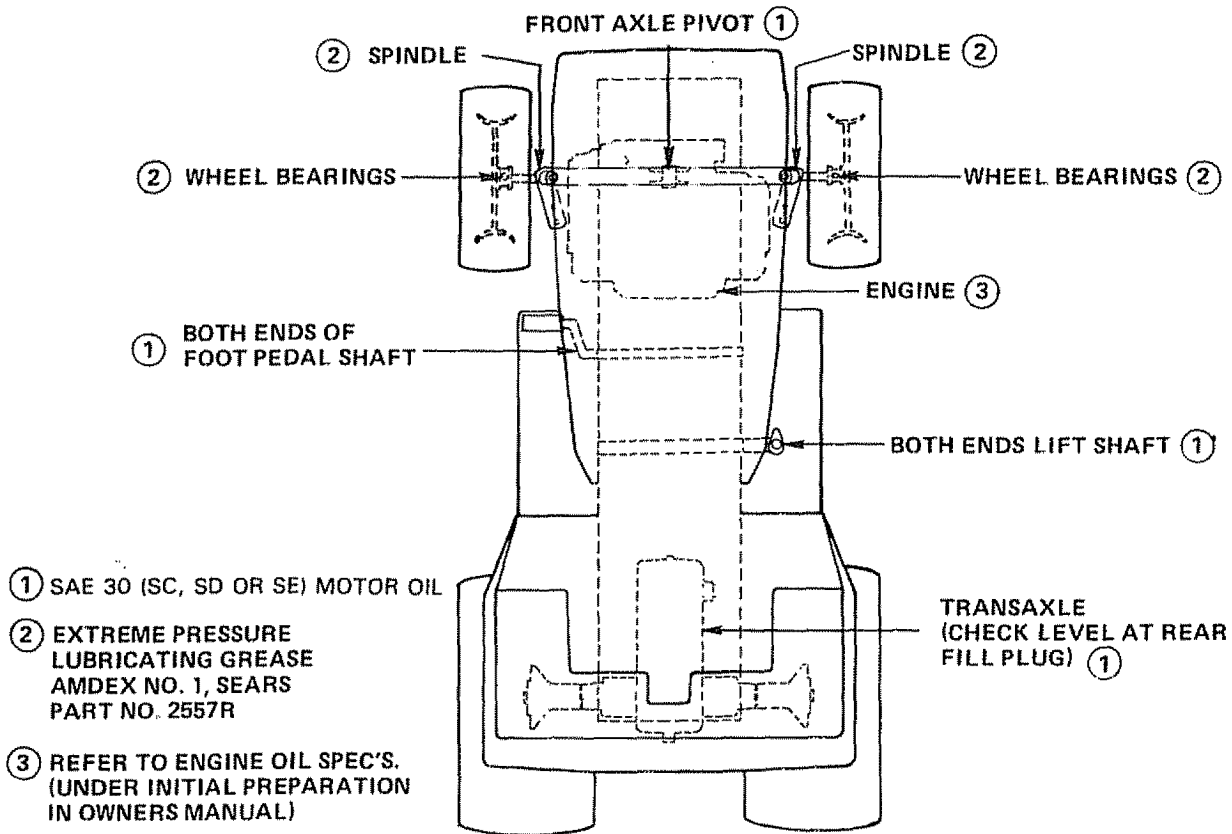

FIGURE 39

LUBRICATION CHART



6. CLEAN BATTERY AND TERMINALS

Corrosion and dirt on the Battery and Terminals cause the Battery to "leak" power and hinders the operation of the charger.

- Remove Terminal Guard. Remove the battery from the tractor and wash with four tablespoons of baking soda to one gallon of water. NOTE: BE CAREFUL NOT TO GET THE SODA SOLUTION INTO THE CELLS. Rinse the Battery with plain water, dry and reinstall on Tractor.
- Clean terminals and cable ends with a wire brush until bright. Replace Battery Cables. Coat terminal connections with Vasoline. Replace Terminal Guard.

EVERY 50 HOURS

(OPERATING IN DUSTY CONDITIONS MAY REQUIRE MORE FREQUENT SERVICING)

1. CLEAN AIR FILTER

- Unscrew Knob (Fig. 39) to remove Cover.
- Remove Nut and Washer to remove Cartridge Plate, Paper Cartridge and Oil Foam Pre-Cleaner.
- Wash Foam Pre-Cleaner in detergent and water.
- Rinse, squeeze (rather than twist) and allow to dry thoroughly.
- Coat with three Tablespoons of S.A.E. 30 Engine Oil, squeeze to distribute evenly, and squeeze out excess.
- Check Paper Cartridge, Replace if excessively dirty.
- Reassemble Paper Cartridge and re-position on Tractor. NOTE: NEVER RUN ENGINE WITH AIR CLEANER REMOVED AS DIRT (DUST) WILL DAMAGE THE ENGINE.

2. CHANGE ENGINE OIL

The best time to drain Engine Oil is at the end of a day's operation when all dirt and foreign materials are suspended in the hot Oil. Refer to page 17.

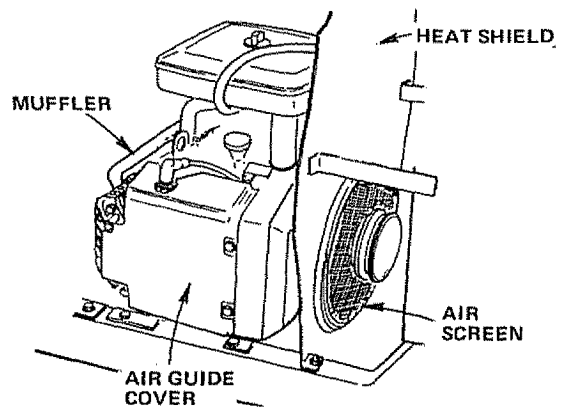

FIGURE 40

3. CLEAN ENGINE COOLING FINS

Remove any dust, dirt or oil from Engine Cooling Fins to prevent Engine damage from overheating (Fig. 41). Air Guide Covers must be removed (Fig. 40).

4. MUFFLER

Do not operate the tractor without a Muffler (Fig. 40) or tamper with the exhaust system. Damaged Mufflers or spark arresters could create a fire hazard. Inspect periodically and replace if necessary. If your engine is equipped with a spark arrester screen assembly, remove every 50 hours for cleaning and inspection. Replace if damaged.

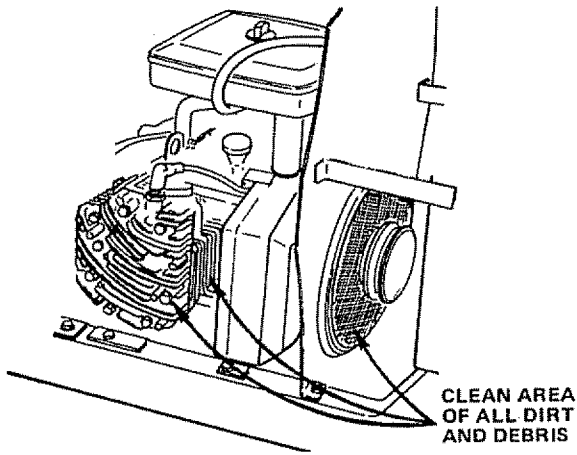

FIGURE 41

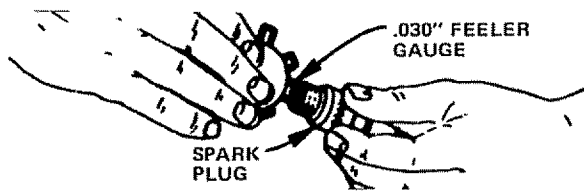

FIGURE 42

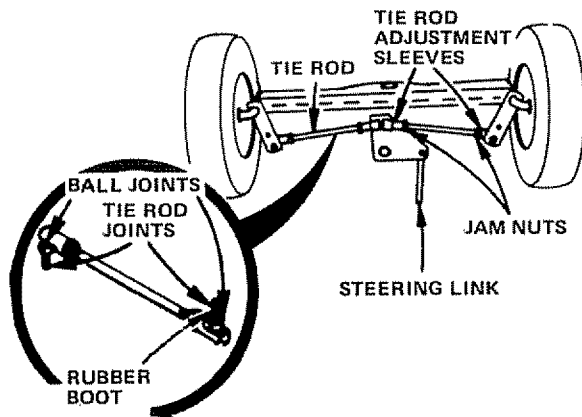

FIGURE 43

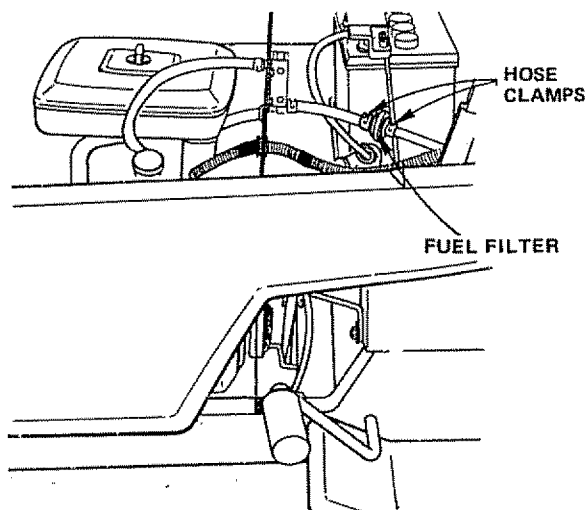

FIGURE 44

EVERY 100 HOURS

1. REPLACE SPARK PLUGS

Replace Spark Plugs at the beginning of each season or every 100 hours, whichever comes first. Gap should be set at .030 inch (Fig. 42).

2. LUBRICATE BALL JOINTS

- Move Rubber Boots to expose Ball Joints on Tie Rods and Steering Link (Fig. 43).
- Coat Ball Joints with Silicone Spray Lubricant.
- Reposition Rubber Boots.

3. REPLACE AIR CLEANER PAPER CARTRIDGE

Refer to page 19.

EVERY 200 HOURS

REPLACE IN-LINE FUEL FILTER

- Remove Hose Clamps from Fuel Lines at Fuel Filter (Fig. 44).
- Remove Fuel Filter.
- Place new Fuel Filter in position with fuel line (arrow on side of Filter in direction of Fuel Filter) and reinstall Hose Clamps.



BE SURE THERE ARE NO FUEL LINE LEAKS AND THAT HOSE CLAMPS ARE PROPERLY INSTALLED.

AS NEEDED

- Make sure all nuts on bolts are tight and cotter pins are secure. Observe all safety precautions. Keep Tractor well lubricated (refer to page 18).
- TOE-IN ADJUSTMENT**
If any parts in Front Axle or Steering Mechanism are being replaced, Toe-In adjustment is required.
 - Loosen Jam Nuts (Fig. 46) at each end of Tie Rod Adjustment Sleeves.
 - Adjust both Tie Rods so that Tie Rod Joints measure 9 - 5/8" from center to center.
 - On front of front tires measure distance from center to center (measurement No. 1).
 - On rear of front tires measure distance from center to center (measurement No. 2).

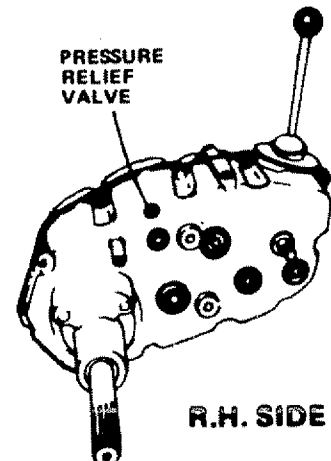

FIGURE 45

- e. Compare measurements - measurement No. 1 should be 1/8 - 1/4 less than measurement No. 2.
- f. If not adjust each Tie Rod equally to get correct measurement.
- g. Tighten Jam Nuts making sure Tie Rod Joints are parallel (180°) to each other. This adjustment secures proper front wheel Toe-In and Steering operation.

3. CHECK TRANSAXLE OIL LEVEL

- a. Remove Filler Plug (Fig. 47) from Transaxle. Oil Level should be even with Filler Plug threads. Add S.A.E. 30 (SC, SD OR SE) Motor Oil if necessary.
- b. Check Pressure Relief Valve (Fig. 45 - Inset) located on R.H. side near top. It should spring completely closed when pulled out by hand and released.

4. THROTTLE CONTROL CABLE ADJUSTMENTS

Never attempt to change maximum engine speed. This is preset at the factory (3400 ± 100 RPM) and should only be changed by a qualified service technician who has the necessary equipment.

- a. Remove hood, page 24.
- b. Loosen casing clamp screw until throttle cable is free to move.
- c. Move throttle control (on the dash board) to "Fast" position.
- d. Pull throttle cable tight (until swivel is against side of quarter circle). Fig. 48. Retighten casing clamp screw.



REFER TO "STARTING THE ENGINE", PAGE 6.

5. CARBURETOR ADJUSTMENT

NOTE: Adjust throttle control cable before making any adjustment to carburetor. Air cleaner must be assembled to carburetor when running engine.

Minor carburetor adjustments may be required to compensate for differences in fuel, temperature or altitude. Adjust the carburetor fuel mixture as follows:

- a. Gently turn idle mixture valve clockwise (↻) Fig. 49 until it just closes and then counterclockwise (↻) 1 1/2 turns.
CAUTION: Valve may be damaged if turned in too far.
- b. Start engine and allow to warm for five minutes. Make final adjustments with engine running and choke pushed in.
- c. Move throttle control lever (on dashboard) to slow position.
- d. Hold governor control lever against idle speed screw, and adjust idle speed screw to obtain 1200 to 1400 RPM. Fig. 49.
- e. While still holding the governor control lever against idle stop, turn idle mixture valve slowly clockwise (↻) (lean mixture) until speed just starts to slow.
- f. Turn idle mixture valve back to the midpoint between rich and lean.
- g. Adjust the idle speed screw to obtain 900 to 1200 RPM. Release governor control lever.
- f. Move throttle control (on the dashboard) to "FAST". If engine hesitates or dies, turn idle mixture valve approximately 1/8 turn counterclockwise (↻) until engine will accelerate as throttle control is moved from "SLOW" to "FAST".

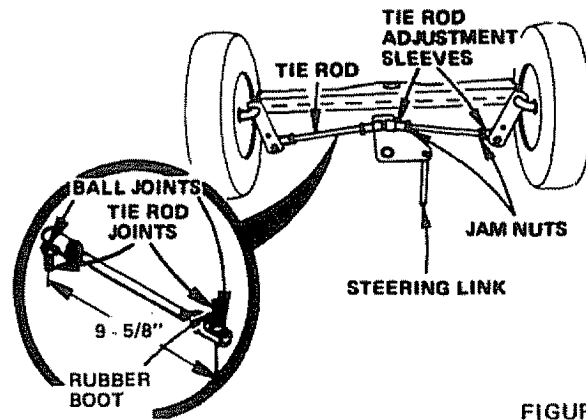

FIGURE 46

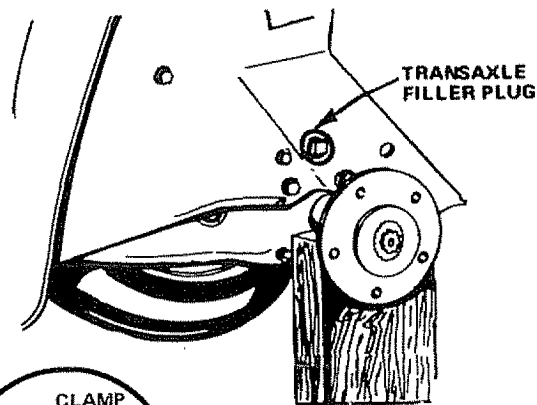

FIGURE 47

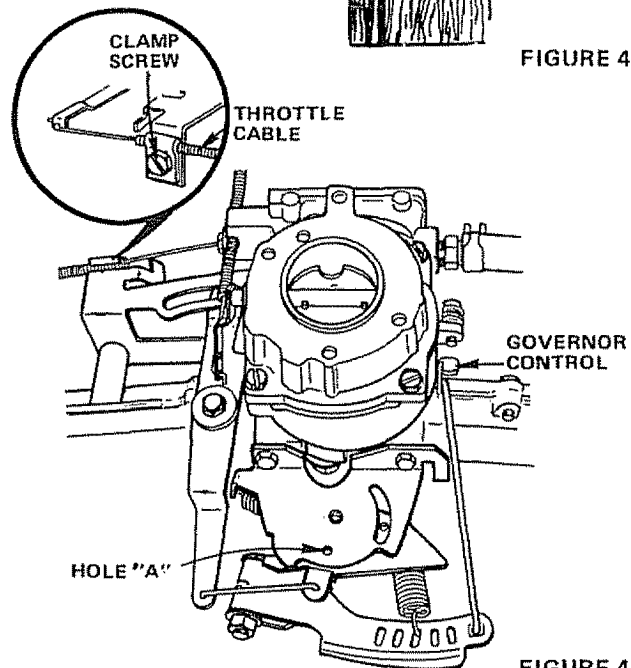

FIGURE 48

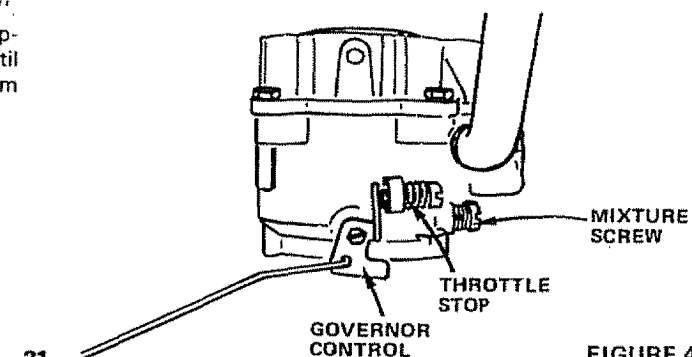

FIGURE 49

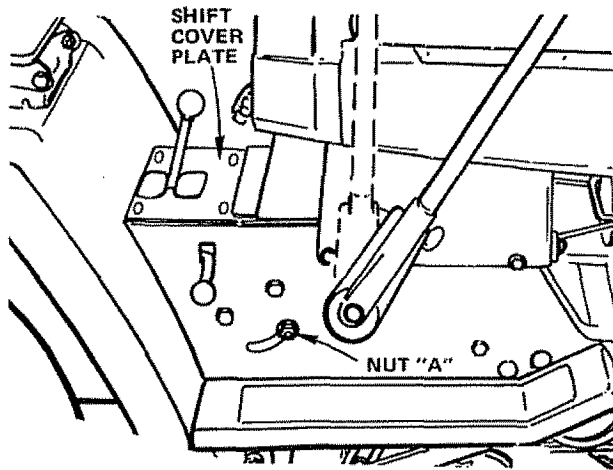

FIGURE 50

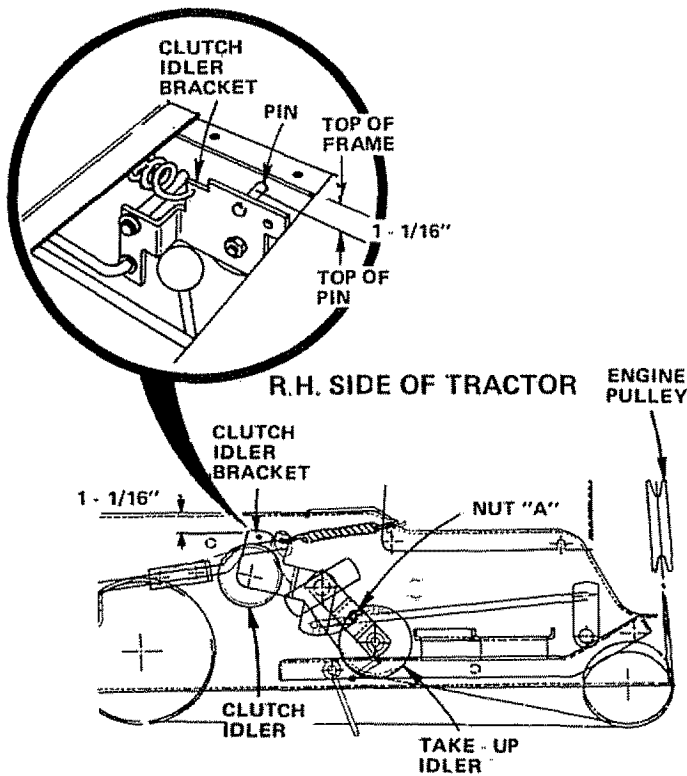

FIGURE 51

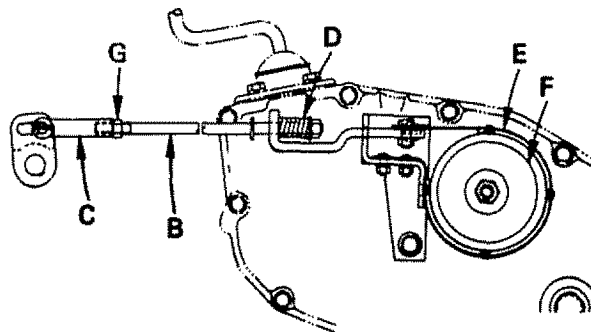

FIGURE 52

6. V-BELT ADJUSTMENT

To assure maximum belt life check belt adjustment seasonally.

- To tighten Belt, remove (4) Hex Washer Head Tapping Screws from Shift Cover Plate (Fig. 50) located on top of tractor frame. Remove the Cover Plate.
- Place Parking Brake Lever in "ENGAGED" position. Refer to "Stopping Your Tractor, page 7.
- Loosen Nut "A" located on outside of R.H. Chassis Frame (Fig. 50), slide Take-Up Idler down approximately 1/2" and tighten Nut "A".
- Disengage Parking Brake.
- Check position of Clutch Idler Bracket (Fig. 51).
- Repeat steps b thru e until a 1 - 1/16" dimension is obtained between top of Pin and top of Frame as shown in Fig. 51.
- Tighten Nut "A" securely. NOTE: AFTER ADJUSTING V-BELT YOU MUST READJUST BRAKE, SEE STEP 6.
- Reinstall Shift Cover Plate and (4) Screws removed in step a.

7. BRAKE ADJUSTMENT



IF TRACTOR REQUIRES MORE THAN SIX FEET STOPPING DISTANCE IN HIGHEST GEAR ON A LEVEL DRY CONCRETE OR PAVED SURFACE THEN BRAKE MUST BE ADJUSTED.

- Remove (4) Hex Washer Head Tapping Screws from Shift Cover Plate (Fig. 50), located on top of tractor frame. Remove the Cover Plate.
- Loosen Jam Nut (G) on Brake Rod (B) at Clevis (C) (Fig. 52). If you find it difficult to loosen Jam Nut (G), remove Cover Plate in L.H. Frame Rail.
- Rotate Brake Rod (B) counterclockwise, (⤴) turning Brake Rod out of Clevis (C) four to six turns.
- Start tractor with Transmission in "NEUTRAL" position.
- Depress Brake-Clutch Pedal to the point where Belt stops moving. Hold Brake-Clutch Pedal in position by engaging Parking Brake. If Belt begins to move after engaging Parking Brake, depress Brake-Clutch Pedal to next notch on Parking Brake.
- Shut engine off. Rotate Brake Rod (B) clockwise by hand, turning Brake Rod into Clevis (C), until tight. Tighten Jam Nut (G) on Brake Rod (B) at Clevis (C) (Fig. 52).
- Reinstall Lift Cover Plate and four (4) Mounting Screws. If Cover Plate was removed in step b it should be replaced.

8. V-BELT REPLACEMENT

BELT REMOVAL

The belt on this tractor is special for this application. Always replace with the Sears belt number in the parts list. It is not necessary to remove mower.

- Raise hood and disconnect negative ground battery cable.
- Set parking brake (to get belt slack).
- Loosen (do not remove) two Engine Pulley Belt Guide Bolts and swivel R.H. side of Belt Guide up. Tighten L.H. Bolt to hold Belt Guide in position (Fig. 53).
- Roll Belt off Engine Pulley.
- Roll Belt off "V" Idler, Flat Idler and Adjustable Idler Pulleys (Fig. 54).
- Pull Belt off Clutch Pulley - between Pulley and Frame. Pull Belt off Transaxle Pulley.
- Loosen Nut "A" on R.H. outside of Frame (Fig. 56).

BELT INSTALLATION

NOTE: THERE IS A BELT INSTALLATION DECAL UNDER LEFT HAND FOOTREST.

- Push Belt down from Engine Pulley area. Place back (flat) side of Belt on Flat Idler. (Flat Idler is next to Frame.)
- Place Belt on Adjustable Idler and over Clutch Pulley. "V" (narrow) part of Belt should engage Clutch Pulley.
- Place Belt around Transaxle Pulley. "V" part of Belt should engage Transaxle Pulley.
- Make sure "V" part of Belt engages "V" Idler (Fig. 54).
- Roll Belt over Engine Pulley.
- Loosen L.H. Engine Pulley Belt Guide Bolt and swivel Belt Guide onto R.H. Bolt. Tighten L.H. and R.H. Bolts securely (Fig. 55).
- Release Parking Brake, NOTE: WHEN A NEW BELT HAS BEEN INSTALLED, YOU MUST CHECK V-BELT ADJUSTMENT AND BRAKE ADJUSTMENT.

9. TIRE CARE

- Maintain tire pressure in front at 14 PSI and rear tires at 10 PSI.
- Keep tires free of gasoline, oil, or insect control chemicals which can destroy rubber.
- Avoid stumps, stones, deep ruts and other hazards that may cause tire damage.
- Removing front wheel for tire repair (Fig. 57).
 - Block up front axle securely.
 - Remove Hub Cap, Klip Ring and Washers to allow wheel removal.
 - Repair tire and reassemble. Replace Washers and snap Klip Ring securely in axle groove. Replace Hub Cap.
- Removing rear wheel for tire repair.
 - Block up rear axle securely.
 - Remove Hub Cap and (5) Hub Bolts to allow wheel removal.
 - Repair tire and reassemble. Replace and tighten Hub Bolts and Hub Cap securely.



WHEN MOUNTING TIRES, BEADS MUST BE SEATED. OVERINFLATION CAN CAUSE A FATAL EXPLOSION.

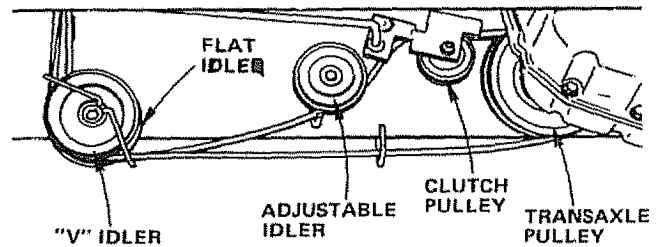

FIGURE 54

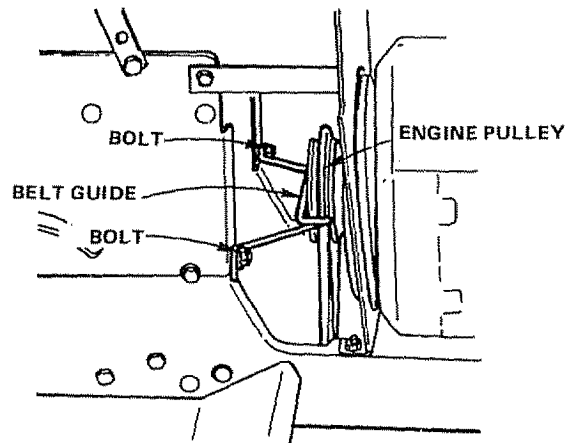

FIGURE 55

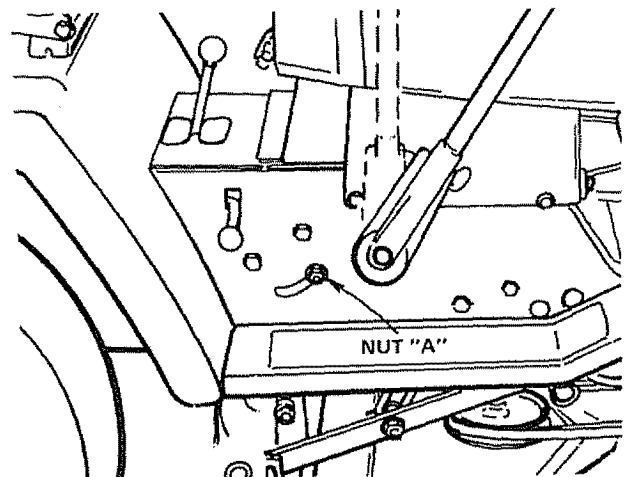

FIGURE 56

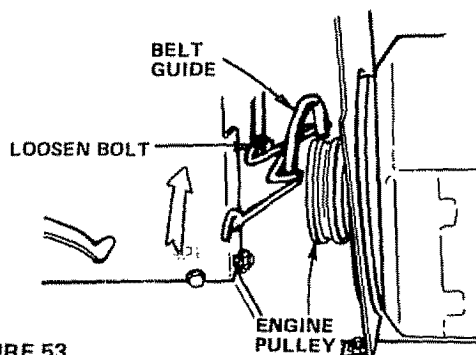

FIGURE 53

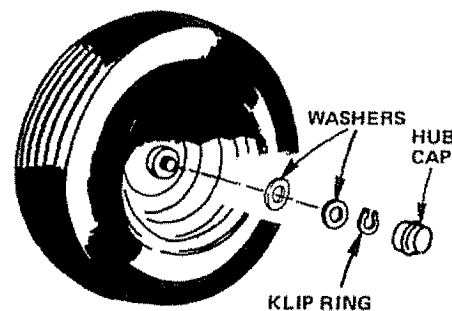

FIGURE 57

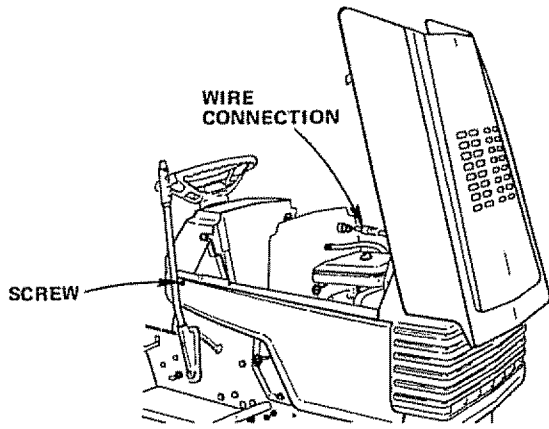

FIGURE 58

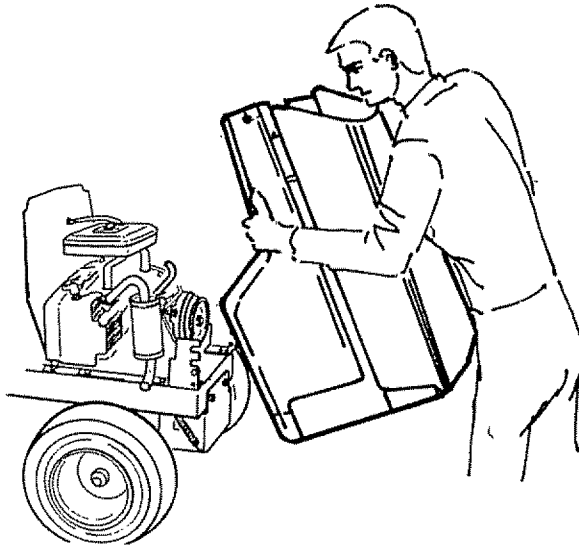

FIGURE 59

10. FINISH

Keep tractor finish and seat free of gasoline, oil, insect chemicals or battery electrolyte. Protect painted surfaces with automotive type wax.

11. HOOD REMOVAL

- a. Lift Hood. Disconnect Headlight Wiring Connection (Fig. 58).
- b. Unscrew one Screw at rear of each Side Panel (Fig. 58).
- c. Pivot Hood and Side Panel forward and lift off tractor (Fig. 59).
- d. To replace, reverse the above procedure.

12. ELECTRIC CLUTCH ADJUSTMENT

- a. Make sure Attachment Clutch and Ignition Switches are in the "OFF" position.
- b. Adjust the three nylon locknuts "B" until the space between the Clutch Plate and rotor measures .012 at all three slot locations cut in the side of the Brake Plate (Fig. 60).

NOTE: After installing new Electric Clutch, run Tractor at full throttle and Engage and Disengage Electric Clutch 10 cycles to wear in Clutch Plate.

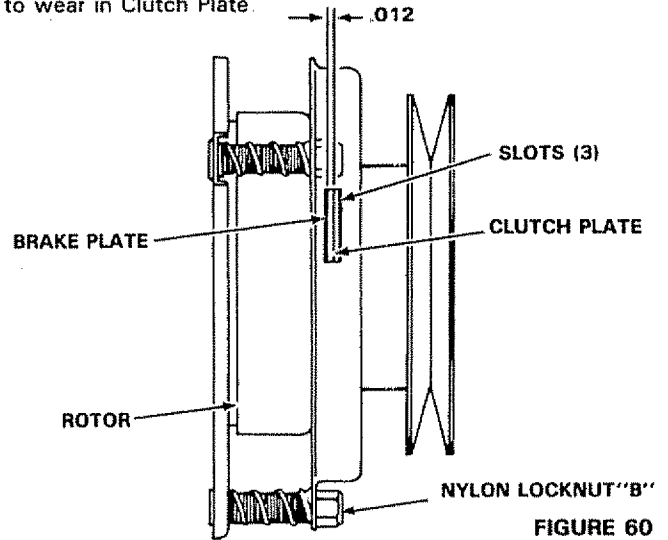

FIGURE 60

SERVICE RECORD FILL IN DATES AS YOU COMPLETE REGULAR SERVICE	SERVICE INTERVALS					SERVICE DATES
	AS NEEDED	EVERY 8 HOURS	EVERY 25 HOURS	EVERY 50 HOURS	EVERY 100 HOURS	
Check Engine Oil Level	✓					
Change Engine Oil (see chart, page 6)			✓			
Lubricate Pivot Points (see page 19)		✓				
Check Brake Operation	✓					
Clean Air Screen		✓				
Clean Air Filter			✓			
Replace Air Cleaner Paper Cartridge				✓		
Clean Engine Cooling Fins			✓			
Replace Spark Plug				✓		
Check Battery Level		✓				
Check Tire Pressure	✓					
Replace Fuel Filter					✓	



TROUBLE SHOOTING	
POSSIBLE CAUSE	POSSIBLE REMEDY
WILL NOT START Clutch-Brake Pedal in drive position Attachment Clutch Switch in "ENGAGED" position No gasoline in Fuel Tank or clogged Fuel Line or Fuel Filter Blown Fuse Dead Battery Defective Ignition or loose Wiring Spark Plug fouled	Push Pedal into brake position (Fig. 8) Move Switch to "DISENGAGED" position (Fig. 9) Fill Tank with fresh Gasoline. Check Fuel Line (Fig. 44) and Carburetor (clean if necessary) Check for fault and replace Fuse Recharge or replace Battery Check Wiring Replace Spark Plug and adjust gap (Fig. 42)
HARD TO START Choked improperly, flooded Engine Clogged Fuel Tank, Fuel Line or Fuel Filter Spark Plug fouled Defective Battery Defective Ignition or loose wiring Water in gasoline or old fuel Improper Carburetor adjustment Poor compression	Place Throttle Control in fast position (Fig. 9) and run starter several times to clean out gas Remove and clean (Fig. 44) Replace Spark Plug and adjust gap (Fig. 42) Recharge or replace Check the wiring and Spark Plugs Drain Fuel Tank and Carburetor, use fresh fuel and replace Spark Plug Make necessary adjustments (Fig. 48) Major engine overhaul
ENGINE MISSES OR LACKS POWER Engine overloaded Clogged Fuel Filter Clogged Fuel Tank Partially plugged Air Cleaner Improper Carburetor adjustment Dirty Air Screen Low oil level Spark Plug fouled, improper gap or wrong type Faulty ignition Poor compression Gasoline in oil Dirty Air Cleaner	Shift to a lower gear or reduce load Remove and replace (Fig. 44) Remove and clean Remove and clean (Fig. 39) Make necessary adjustments (Fig. 48) Clean Air Screen, Cylinder Fins (Fig. 41) and Muffler area Add or change oil (Fig. 35) Replace Spark Plugs and adjust gap (Fig. 42) Check Spark Plugs and for any loose wires Major Engine overhaul Drain Engine oil and refill Remove and clean (Fig. 39)
ENGINE OVERHEATS Dirty Air Screen Low oil level Dirty Engine Partially plugged Muffler Improper Carburetor adjustment	Clean Air Screen (Fig. 40) Add or change oil (Fig. 35) Clean Cylinder Fins, rotating Screen and Muffler area Remove and clean Muffler (Fig. 40) Adjust Carburetor (Fig. 48)
NO LIGHTS No Headlight with Light Switch in "ON" position and engine running	Check Wire Connections and Switch, Replace Light Bulbs
WON'T CHARGE Blown Fuse Defective Battery	Check for fault and replace Replace

STORAGE

1. FUEL SYSTEM

NOTE: THE USE OF A FUEL ADDITIVE, SUCH AS STABIL, OR AN EQUIVALENT, WILL MINIMIZE THE FORMATION OF FUEL GUM DEPOSITS DURING STORAGE. SUCH AN ADDITIVE MAY BE ADDED TO THE GASOLINE IN THE FUEL TANK OF THE ENGINE, OR TO THE GASOLINE IN A STORAGE CONTAINER.

If Sta-Bil is not used all fuel should be removed from fuel tank.

a. Drain fuel tank and carburetor by allowing the engine to run out of gasoline. NOTE: GASOLINE LEFT IN YOUR ENGINE WILL LEAVE GUM DEPOSITS CLOGGING FUEL SYSTEM.

b. Dispose of gasoline if not to be used. NOTE: GASOLINE STORED FOR SEVERAL MONTHS LOSES ITS VOLATILITY (ABILITY TO BURN EFFECTIVELY).

2. ENGINE OIL

Drain (with engine warm) and replace with clean engine oil. (See chart, page 6).

3. CYLINDERS

a. Remove Spark Plugs.

b. Pour one ounce of oil through spark plug holes into cylinders.

c. Turn Ignition Key to "START" position for a few seconds to distribute oil.

d. Replace with new Spark Plugs.

4. BATTERY

a. Remove battery if tractor is not used regularly during winter months. Store in cool, dry place (above 50°F.). CAUTION: A DIRTY BATTERY CAN RUIN A FLOOR. CLEAN BATTERY BEFORE STORAGE.

b. Re-charge each month at 6 amps for 1 hour if necessary. NOTE: BATTERIES NOT IN USE FOR SEVERAL MONTHS AND NOT KEPT FULLY CHARGED, PRODUCE SULPHATE. DEPOSITS ON PLATES WHICH CANNOT BE REMOVED BY RECHARGING.

5. GENERAL CLEANING

Clean engine, battery, seat, finish, etc. of all foreign matter.

6. STORE IN A CLEAN AND DRY AREA.

Sears, Roebuck and Co. reserves the right to make any changes in design or improvements without imposing any obligation to install the same upon its items heretofore manufactured.

REPAIR PARTS

GT 18 TWIN GARDEN TRACTOR--MODEL NUMBER 917.255915
CHASSIS AND ENCLOSURES

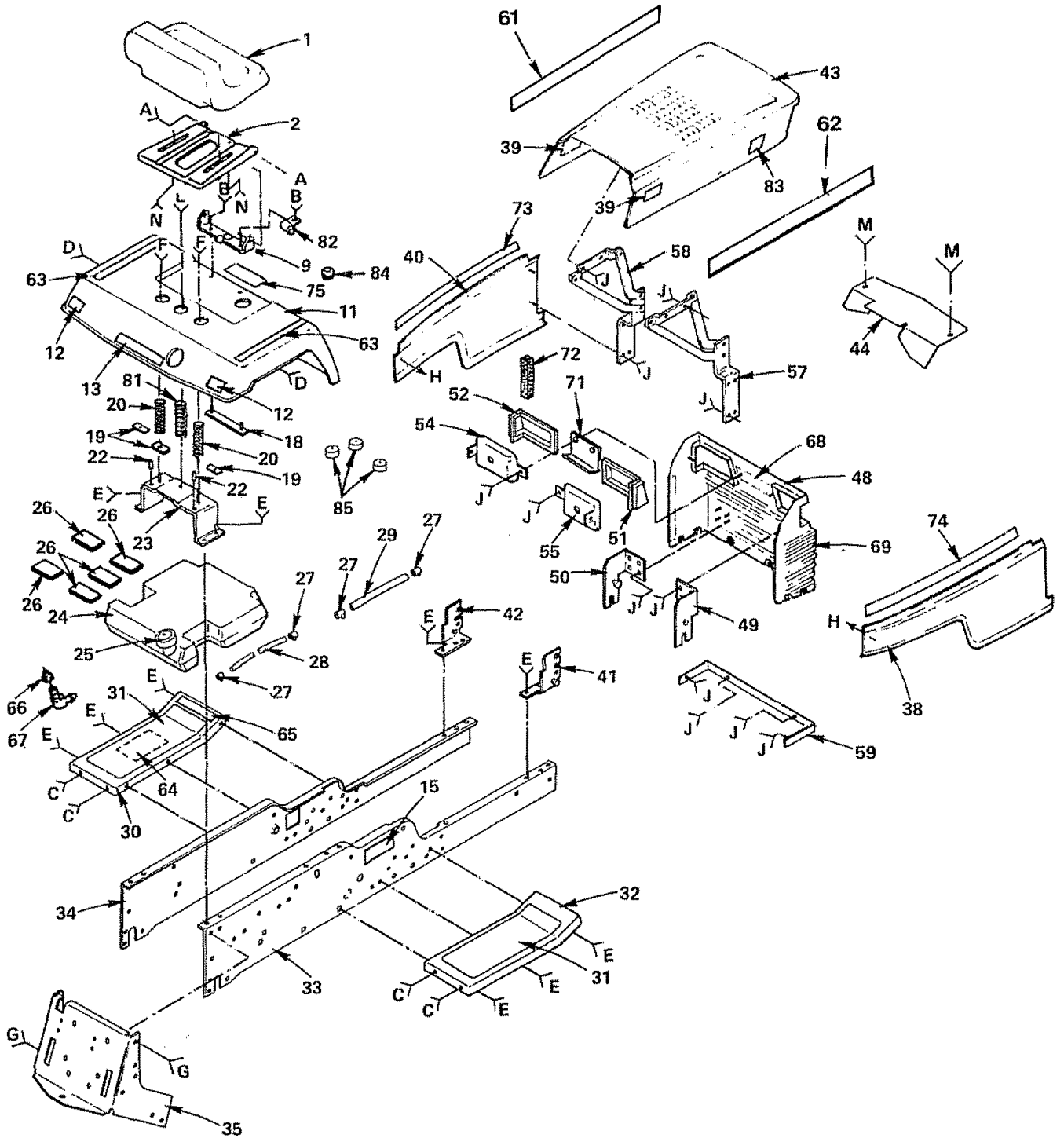

REPAIR PARTS

GT 18 TWIN GARDEN TRACTOR--MODEL NUMBER 917.255915

CHASSIS AND ENCLOSURES

KEY NO.	PART NO.	DESCRIPTION	KEY NO.	PART NO.	DESCRIPTION
1	110053X	Seat	41	108508X	Bracket - Pivot - Frame - R.H.
2	109866X	Pan - Seat	42	108509X	Bracket - Pivot - Frame - L.H.
3	105529X	Bolt - Shoulder	43	106013X	Hood
5	73680500	Nut - Lock 5/16 - 18	44	106087X	Shield, Heat, Front
9	110378X	Bracket - Pivot Seat	48	105528X	Grill
10	73680600	Nut - Lock 3/8 - 16	49	108512X	Bracket - Pivot - Grill - R.H.
11	109593X	Fender	50	108513X	Bracket - Pivot - Grill - L.H.
12	106202X	Reflector - Taillight	51	106003X	Lens - R.H.
13	105801X	Decal	52	106004X	Lens - L.H.
14	STD523707	*Bolt - Hex 3/8 - 16 x 3/4	54	106006X	Bezel - L.H.
15	105567X	Decal - Chassis	55	106005X	Bezel - R.H.
16	17490608	Screw - Hex Washer Thread Rolling 3/8 - 16 x 1/2	56	108067X	Pal Nut
17	17490616	Screw - Hex Washer Thread Rolling 3/8 - 16 x 1	57	106091X	Hinge - R.H.
18	105511X	Strap - Fender	58	106090X	Hinge - L.H.
19	105514X	Clamp - Spring	59	105524X	Strap - Grill
20	105512X	Spring - Compression	61	108743X	Decal - Stripe, L.H.
21	19132012	Washer 13/32 x 1 - 1/4 x 12 Ga.	62	108744X	Decal - Stripe, R.H.
22	105531X	Nut - Push	63	109139X	Decal - Fender
23	105509X	Bracket - Fender	64	106868X	Decal - Drive Schematic
24	106020X	Tank - Fuel	65	4900J	Decal - Clutch/Brake
25	109462X	Cap - Fuel	66	3645J	Bushing
26	106082X	Pad - Spacer	67	8710J	Stem - Tank, Fuel
27	6999R	Clamp - Hose	68	105806X	Decal - Grill
28	7834R	Line - Fuel	69	105568X	Decal - Grill (Stripe)
29	7833R	Line - Fuel	70	19131416	Washer 13/32 x 7/8 x 16 Ga.
30	105465X	Footrest - L.H.	71	106092X	Support, Heat Shield
31	105466X	Pad - Footrest	72	106088X	Strip - Foam
32	105464X	Footrest - R.H.	73	106813X	Decal - Stripe, Side Panel, L.H.
33	110892X	Rail - Frame - R.H. **	74	106814X	Decal - Stripe, Side Panel, R.H.
34	110893X	Rail - Frame - L.H. **	75	106974X	Decal - OPEI - Caution
35	7982J	Drawbar	76	STD551137	*Washer - Lock 3/8
36	74760716	Bolt - Hex 7/16 - 14 x 1	77	19131312	Washer 13/32 x 13/16 x 12 Ga.
37	73680700	Nut - Lock 7/16 - 14	78	106909X	Screw - Special
38	108403X	Panel - Side - R.H.	79	106910X	Washer
39	105562X	Decal	80	108402X	U-Clip
40	108410X	Panel - Side - L.H.	81	109867X	Spring, Compression
			82	2751R	Clip - Fuel Line
			83	108631X	Decal II
			84	109641X	Grommet
			85	109412X	Spring, Cap

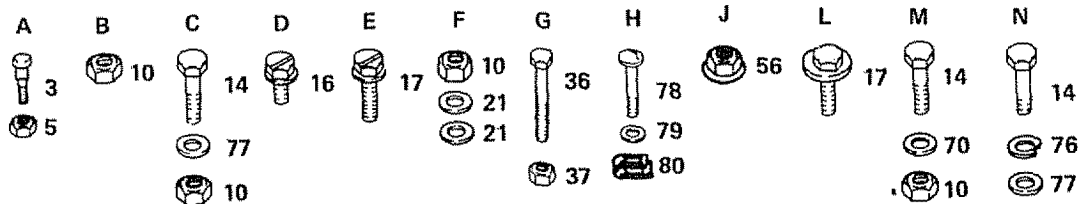

NOTE: When ordering Frame Rails - If your Tractor does not use a Plastic Bushing on the Foot Pedal (item 129 on page 31), then you must order Right Hand Frame Rail 105506X or Left Hand Frame Rail 105504X.

*STANDARD HARDWARE--PURCHASE LOCALLY

REPAIR PARTS

GT 18 TWIN GARDEN TRACTOR--MODEL NUMBER 917.255915

GROUND DRIVE

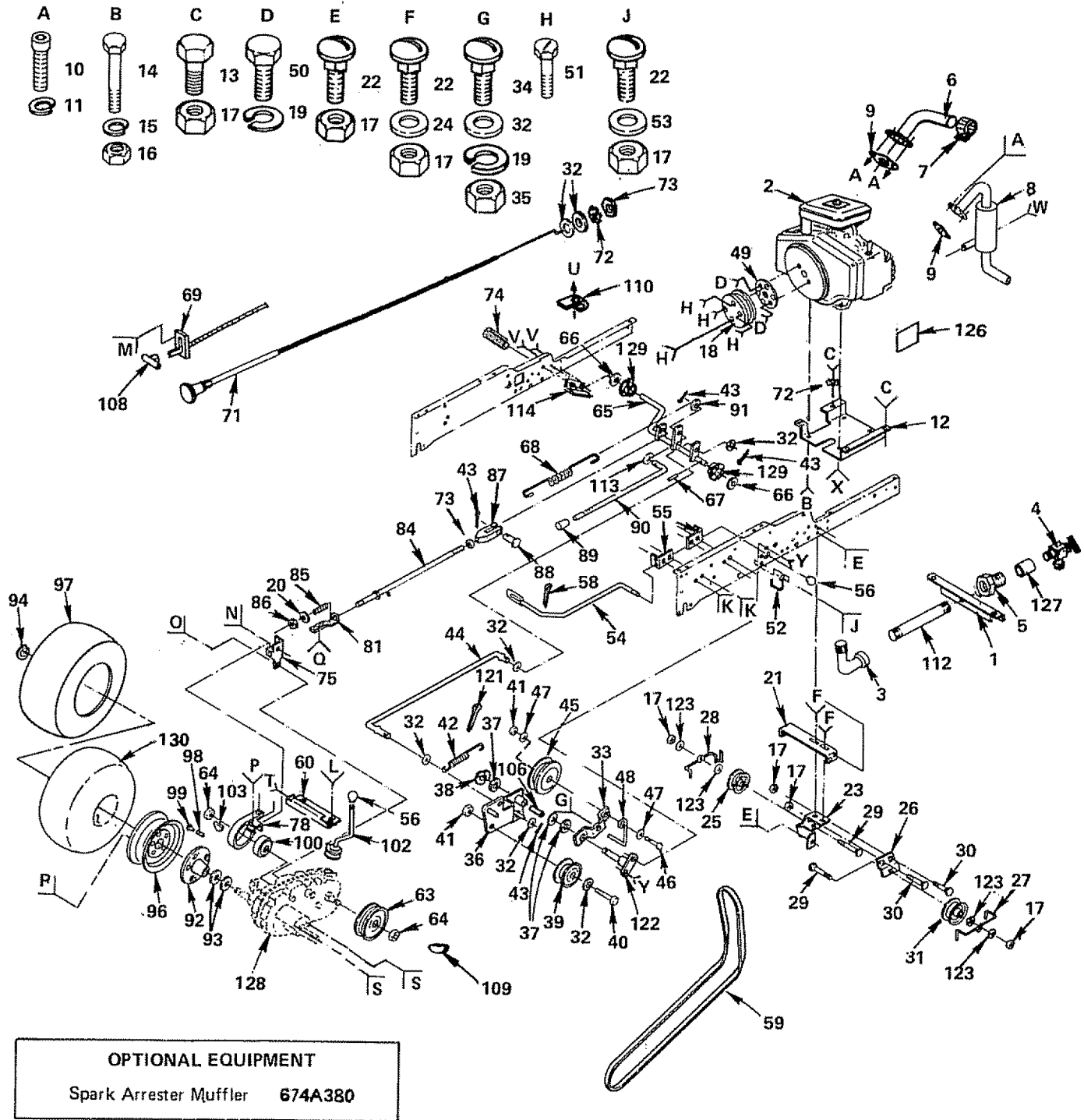

OPTIONAL EQUIPMENT
Spark Arrester Muffler 674A380

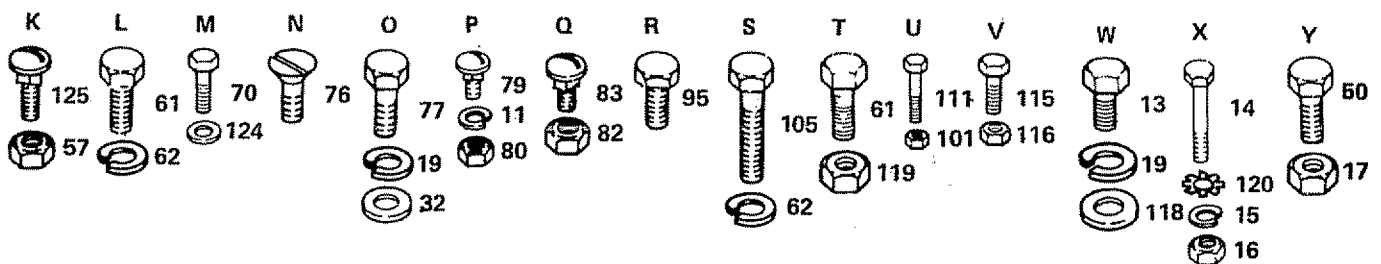

REPAIR PARTS

GT 18 TWIN GARDEN TRACTOR--MODEL NUMBER 917.255915

GROUND DRIVE

KEY NO.	PART NO.	DESCRIPTION	KEY NO.	PART NO.	DESCRIPTION
1	106637X	Bracket, Support	65	104375X	Shaft, Foot Pedal
2	108077X	Engine, 18 H.P., Briggs and Stratton, Model No. 422437, Type No. 0749-01	66	19252016	Washer, 25/32 x 1 - 1/4 x 16 Ga.
3	13240200	Elbow, Street	67	STD571812	Pin, Roll, 3/16 x 1 - 1/4
4	9767H	Valve, Oil Drain	68	106021X	Spring, Extension
5	13260302	Bushing	69	5693J	Control, Throttle
6	100229L	Tube - Exhaust	70	17720408	Screw, Hex, Thd. Cut, 1/4 - 20 x 1/2
7	100000K	Clamp - Tube	71	104596X	Control, Choke
8	108234X	Muffler	72	11050600	Washer, Lock, Ext. Tooth, 3/8
9	8545J	Gasket, Muffler	73	STD541137	*Nut, 3/8 - 24
10	74570412	Screw, Socket Hd., 1/4 - 20 x 3/4	74	8883R	Cover, Pedal
11	STD551125	*Washer, Lock, 1/4	75	677A637	Bracket, Brake
12	5266J	Base, Engine	76	74370612	Screw, Mach., Unct. Fl. Hd., 3/8 - 16 x 3/4
13	STD523707	*Bolt, Hex, 3/8 - 16 x 3/4	77	74760614	Bolt, Hex, 3/8 - 16 x 7/8
14	STD523112	*Bolt, Hex, 5/16 - 18 x 1 - 1/4, Gr 5	78	7920J	Band, Brake
15	STD551131	*Washer, Lock, 5/16	79	72140405	Bolt, Carr., 1/4 - 20 x 5/8
16	STD541031	*Nut, Hex, 5/16 - 18	80	STD541025	*Nut, Hex, 1/4 - 20
17	73680600	Nut, Lock, 3/8 - 16	81	7229J	Guide, Rod, Brake
18	101343L	Pulley, Ground Drive	82	1685H	Nut, Lock, 5/16 - 18
19	STD551137	*Washer, Lock, 3/8	83	STD533107	*Bolt, Carr., 5/16 - 18 x 3/4
20	19131614	Washer, 13/32 x 1 x 14 Ga.	84	5308J	Rod, Brake
21	105599X	Bracket, Drive, Mule	85	7241J	Spring, Compression
22	72110608	Bolt, Carriage 3/8 - 16 x 1	86	73530600	Nut, Lock, 3/8 - 24
23	106000X	Bracket, V-Pulley, Drive, Mule	87	100604K	Yoke
24	19131612	Washer, 13/32 x 1 x 12 Ga.	88	5102J	Pin, Clevis
25	101344L	Pulley, Idler	89	71673	Cap, Plunger
26	5255J	Bracket, Idler, Flat	90	109767X	Rod, Parking Brake
27	106048X	Guard, Belt, Mule Drive, Flat Idler	91	19111216	Washer, 11/32 x 3/4 x 16 Ga.
28	106023X	Guard, Belt, Mule Drive, V-Idler	92	634A692	Bushing and Wheel Hub
29	72110616	*Bolt, Carr., 3/8 - 16 x 2	93	7563R	Washer, Thrust, Axle
30	STD533707	*Bolt, Carr., 3/8 - 16 x 3/4	94	12000034	Klip Ring
31	102403X	Idler, Flat	95	1304H	Bolt, Hub
32	STD551037	*Washer, 13/32 x 13/16 x 16 Ga.	96	106277X	Wheel, Rear
33	101347L	Bracket, Flat Idler	97	105588X	Tire, Rear
34	STD533710	*Bolt, Carr., 3/8 - 16 x 1	98	65139	Valve, Tire
35	STD541037	*Nut, Hex, 3/8 - 16	99	59192	Cap, Valve
36	105592X	Bracket, Clutch w/Bearing (Inc. Key No. 106)	100	214J	Drum, Brake
37	207J	Washer, Hardened	101	STD541410	*Nut - Lock No. 10 - 24
38	12000039	Klip Ring	102	633A109	Gear Shift Lever Assembly
39	110484X	Idler, Grooved	103	2228M	Key, Woodruff
40	STD523715	*Bolt, Hex, 3/8 - 16 x 1 - 1/2	105	74760724	Bolt, Hex 7/16 - 14 x 1 - 1/2
41	73930600	Nut, Lock, 3/8 - 16	106	101350K	Bearing - Idler
42	101355X	Spring, Extension	108	61159	Knob - Throttle Control
43	STD570907	*Pin, Cotter, 3/32 x 3/4	109	9858M1	Key - Woodruff
44	101356L	Rod, Clutch	110	5304J	Actuator - Switch, Interlock
45	104360X	Idler, Flat	111	74321016	Screw - Fin 10 - 24 x 1
46	STD523720	*Bolt, Hex, 3/8 - 16 x 2	112	13280252	Nipple, Pipe
47	19131413	Washer, 13/32 x 7/8 x 13 Ga.	113	19132012	Washer 13/32 x 1 - 1/4 x 12 Ga.
48	105597X	Retainer, Belt	114	104601X	Bracket - Interlock
49	104577X	Adapter	115	STD522507	*Bolt - Hex 1/4 - 20 x 3/4
50	STD523710	*Bolt, Hex, 3/8 - 16 x 1 Gr. 5	116	73680400	Nut - Crownlock 1/4 - 20
51	17190512	Screw, Hex, Slotted, 5/16 - 18 x 3/4	118	19131210	Washer 13/32 x 3/4 x 10 Ga.
52	105500X	Retainer, Belt, Lower	119	73680700	Nut - Crownlock 7/16 - 14
53	19131312	Washer, 13/32 x 13/16 x 12 Ga.	120	11050500	Washer - Lock Ext. Tooth 5/16
54	101345M	Rod, Shift, Hi-Lo	121	76020816	Pin - Cotter 1/4 x 1
55	105598X	Bracket, Rod, Shift	122	101358K	Bracket - Assembly Clutch
56	100196K	Knob	123	19131612	Washer 13/32 x 1 x 12 Ga.
57	73680500	Nut, Lock, 5/16 - 18	124	STD551025	*Washer 9/32 x 5/8 x 16 Ga.
58	STD571810	*Pin, Cotter, 3/16 x 1	125	72140506	Bolt - Carriage 5/16 - 18 x 8/4
59	101342N	V-Belt	126	110042X	Decal, 18 H.P. Craftsman
60	120404X	Bracket, Support, Transaxle	127	13300300	Coupling, Pipe, Std. 3/8 - 18 NPT
61	74760716	Bolt, Hex, 7/16 - 14 x 1	128	105474X	Transaxle Assembly (less Brake Drum and Shift Lever)
62	STD551143	*Washer, Lock 7/16	129	110895X	Bushing, Flanged
63	101341M	Pulley, Transaxle	130	7154J	Tube, Tire (not furnished with tractor)
64	9204H	Nut, Lock, 1/2 - 20			

REPAIR PARTS

GT 18 TWIN GARDEN TRACTOR--MODEL NUMBER 917.255915

STEERING

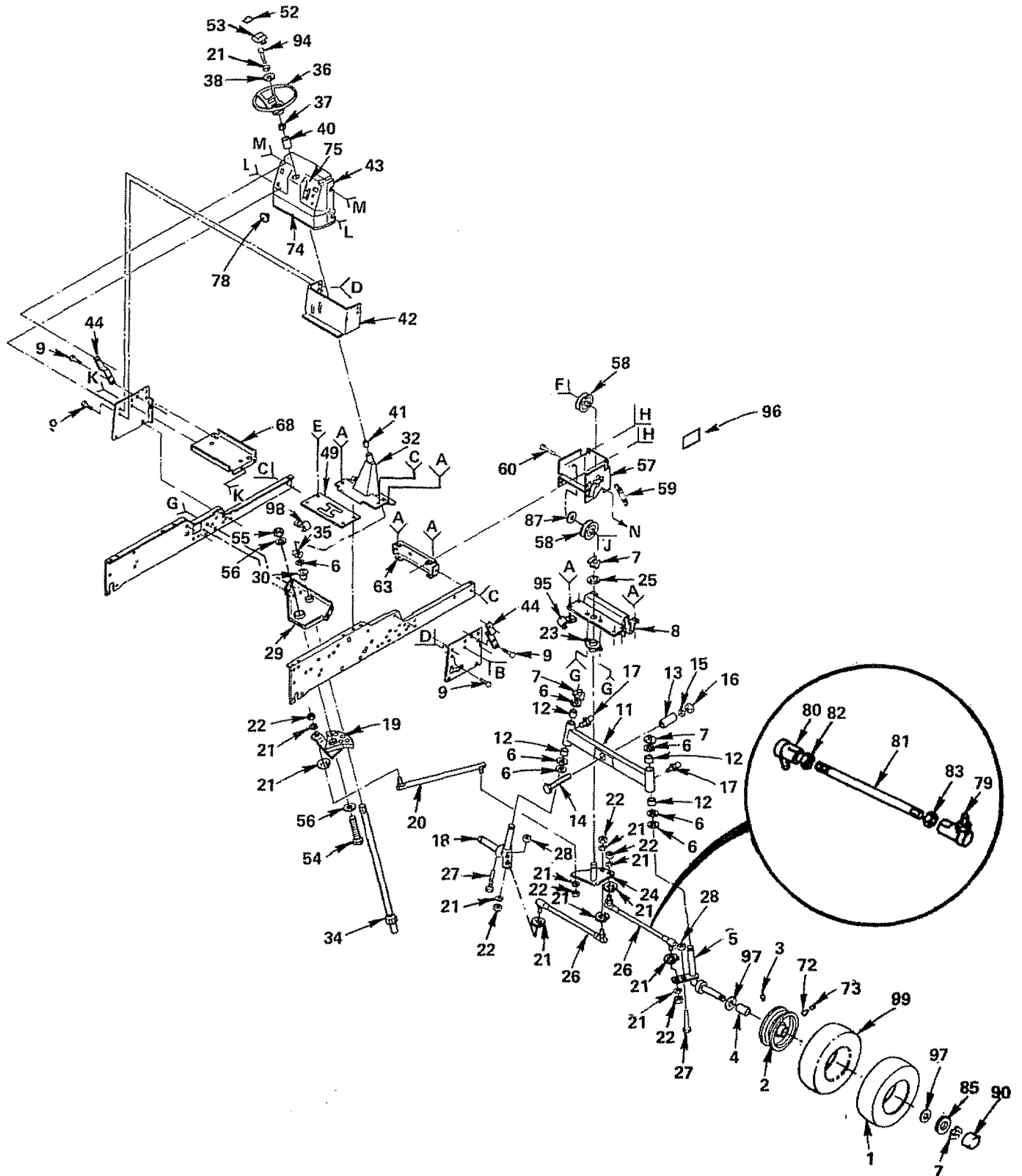

REPAIR PARTS

GT 18 TWIN GARDEN TRACTOR--MODEL NUMBER 917.255915

STEERING

KEY NO.	PART NO.	DESCRIPTION	KEY NO.	PART NO.	DESCRIPTION
1	106230X	Tire, 16 x 6 50	44	105525X	Bracket, Support, Dash
2	106228X	Front Wheel (Inc. Key No. 3 and 2 of Key No. 4)	45	19171416	Washer 17/32 x 7/8 x 16 Ga.
3	278H	Fitting, Grease	46	72110622	Bolt - Carr. 3/8 - 16 x 2 - 3/4
4	9040H	Bearing	47	106486X	Spacer
5	106045X	Spindle, R.H.	49	106042X	Cover, Gate, Shift
6	6266H	Bearing, Thrust	51	17240408	Screw, Hex Washer Thd. Cutting 1/4 - 20 x 1/2
7	12000029	Klip Ring	52	105810X	Decal, Insert
8	5284J	Bracket, Axle	53	100710L	Insert, Steering Wheel
9	STD523707	*Bolt - Hex 3/8 - 16 x 3/4	54	STD525020	*Bolt - Hex 1/2 - 13 x 2
10	73680600	Nut, Lock. 3/8 - 16	55	73680800	Nut, Lock 1/2 - 13
11	674A244	Axle, Front, (Inc. Key No. 12)	56	19172610	Washer 17/32 x 1 - 5/8 x 10 Ga.
12	1309H	Bearing	57	108253X	Bracket, Idler
13	5298J	Tube, Pivot, Axle	58	677A451	Pulley, Idler
14	74781044	Bolt, Hex 5/8 - 11 x 2 - 3/4 Gr. 5	59	7190J	Spring
15	STD551162	*Washer, Lock 5/8	60	STD523722	*Bolt, Hex 3/8 - 16 x 2 - 1/4
16	STD541062	*Nut, Hex 5/8 - 11	61	19131413	Washer 13/32 x 7/8 x 13 Ga.
17	6855M	Fitting, Grease	62	STD541037	*Nut - Hex 3/8 - 16
18	106046X	Spindle, L.H.	63	5213J	Bracket, Frame Front
19	108134X	Sector Assembly	67	73680500	Nut, Lock 5/16 - 18
20	108136X	Link, Drag	68	7985J	Support, Battery
21	STD551137	*Washer, Lock 3/8	72	65139	Stem, Valve
22	STD541137	*Nut, Hex 3/8 - 24	73	59192	Cap, Valve
23	5292J	Bushing, Bellcrank	74	108456X	Decal, Dash, Instruction
24	108137X	Bellcrank	75	108811X	Decal, Instruction
25	19292016	Washer 29/32 x 1 - 1/4 x 16 Ga.	76	106615X	Pin, Mounting, Idler Bracket
26	7990J	Rod, Tie	78	8022J	Plug - Dash
27	STD523720	*Bolt, Hex 3/8 - 16 x 2 Gr. 5	79	8921R	Joint - Tie Rod - R.H. Thread
28	73510600	Nut, Keps 3/8 - 16	80	8922R	Joint - Tie Rod - L.H. Thread
29	102439X	Bracket, Support, Steering	81	7919J	Rod - Tie
30	104239X	Bearing, Flanged	82	73700600	Nut - Hex Jam 3/8 - 24 L.H.
31	72110608	Bolt, Carr. 3/8 - 16 x 1 Gr. 5	83	STD541337	*Nut - Hex Jam 3/8 - 24
32	101274N	Support, Steering	84	STD533107	*Bolt - Carriage 5/16 - 18 x 3/4
33	17490612	Screw, Hex Washer Thd. Rolling 3/8 - 16 x 3/4	85	19252616	Washer 25/32 x 1 - 5/8 x 16 Ga.
34	102458X	Shaft, Steering	87	19132007	Washer 13/32 x 1 - 1/4 x 7 Ga.
35	12000034	Klip Ring	88	74930516	Bolt, Hex 5/16 - 18 x 1
36	100713N	Wheel, Steering	90	104757X	Cap - Hub, Front
37	100711L	Adapter, Steering	91	100644K	Spacer
38	19133808	Washer	92	19111416	Washer 11/32 x 7/8 x 16 Ga.
40	106014X	Sleeve, Steering	94	STD523710	*Bolt - Hex 3/8 - 16 x 1
41	9038R	Bearing	95	100207K	Clip - 3/8
42	105519X	Dash, Lower	96	108367X	Decal - Adjustment
43	108408X	Dash	97	19252016	Washer 25/32 x 1 - 1/4 x 16 Ga.
			98	4171R	Clip - Insulated
			99	8134H	Tube, Front (not furnished with tractor)

*STANDARD HARDWARE--PURCHASE LOCALLY

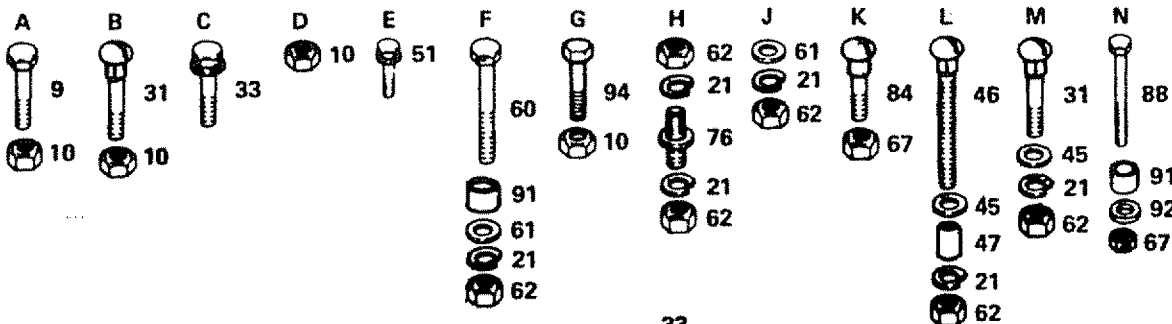

REPAIR PARTS

GT 18 TWIN GARDEN TRACTOR--MODEL NUMBER 917.255915

MOWER LIFT

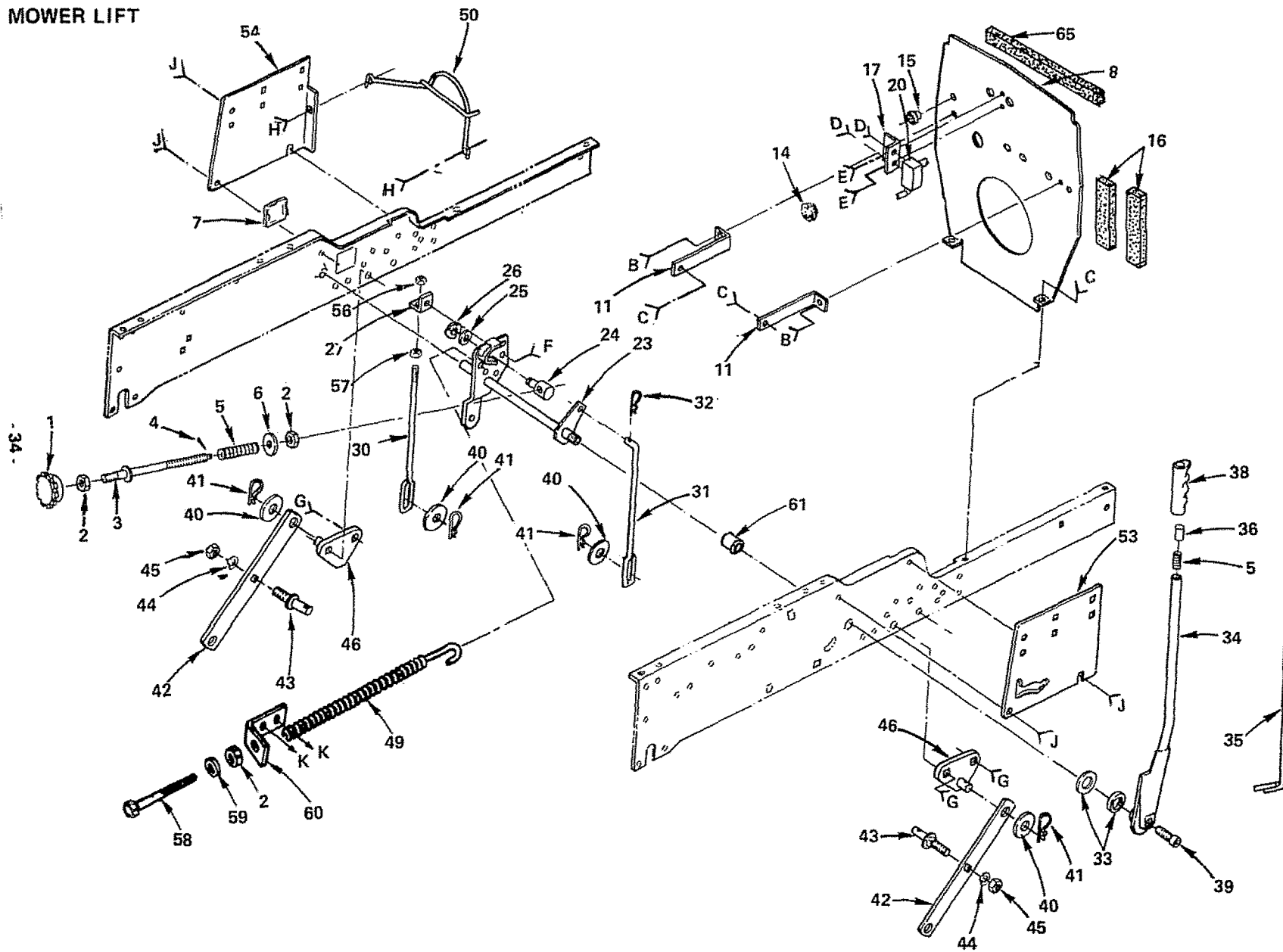

REPAIR PARTS

MOWER LIFT

GT 18 TWIN GARDEN TRACTOR--MODEL NUMBER 917.255915

KEY NO.	PART NO.	DESCRIPTION	KEY NO.	PART NO.	DESCRIPTION
1	100734K	Handle, Adjust, Lift	35	106644X	Rod, Detent
2	STD541237	*Nut, Hex Jam, 3/8 - 16	36	105723X	Plunger, Lever
3	106318X	Rod, Adjust, Lift	37	STD523710	*Bolt - Hex 3/8 - 16 x 1
4	STD570907	*Pin, Cotter, 3/32 x 3/4	38	106019X	Grip, Handle
5	2876H	Spring	39	74570616	Screw, Cap, Hex Socket Head, 3/8 - 16 x 1
6	19131016	Washer 13/32 x 5/8 x 16 Ga.	40	STD551050	*Washer 17/32 x 1 - 1/16 x 13 Ga.
7	105505X	Cover, Access	41	9135R	Retainer Spring
8	105559X	Shield, Heat, Rear	42	105429X	Arm, Suspension
9	STD523107	*Bolt, Hex, 5/16 - 18 x 3/4	43	105413X	Stud, Pivot Center
10	73680500	Nut, Lock, 5/16 - 18	44	STD551150	*Washer, Lock, 1/2
11	105573X	Brace, Heat Shield	45	STD541050	*Nut, Hex, 1/2 - 13
12	STD522505	*Bolt, Hex, 1/4 - 20 x 1/2	46	105501X	Bracket, Suspension, Mower
13	73680400	Nut, Lock, 1/4 - 20	47	STD533707	*Bolt, Carriage, 3/8 - 16 x 3/4
14	106351X	Plug	48	73680600	Nut, Lock, 3/8 - 16
15	110436X	Grommet - Split	49	674A247	Spring - Ass'y. - Assist. Lift
16	105036X	Foam - Strip 6"	50	105589X	Guard, Belt, Engine
17	105040X	Bracket, Fuel Pump	51	STD533110	*Bolt, Carriage, 5/16 - 18 x 1
18	74750806	Screw, Sl. Hex Hd. No. 8 - 32 x 3/8	52	19111610	Washer 11/32 x 1 x 10 Ga.
19	STD551108	*Washer, Lock No. 8	53	121045X	Panel, Side, R.H.
20	105041X	Pump, Fuel	54	121046X	Panel, Side, L.H.
21	STD511005	*Screw, Hex Hd. No. 10 - 24 x 1/2	55	17490608	Bolt, Hex Washer Thd. Rolling, 3/8 - 16 x 1/2
22	73631000	Nut, Lock No. 10 - 24	56	73800600	Nut, Lock, Hex w/Washer, 3/8 - 16
23	105633X	Shaft, Lift	57	STD541037	*Nut, Hex 3/8 - 16
24	6519J	Trunnion, Stop Depth	58	5328J	Bolt - Adjust, Spring, Assist
25	19151216	Washer 15/32 x 3/4 x 16 Ga.	59	STD551037	*Washer 13/32 x 13/16 x 16 Ga.
26	12000037	Klip Ring	60	5329J	Bracket, Spring - Assist
27	7594J	Bracket, Lift, L.H.	61	106012X	Spacer
28	7901J	Bolt, Shoulder	64	73930600	Nut - Centerlock 3/8 - 16
29	73900400	Nut, Hex Flange 1/4 - 20	65	106086X	Strip - Foam
30	7596J	Link, Lift, L.H.			
31	105503X	Link, Lift, R.H.			
32	4939M	Retainer, Spring			
33	105630X	Washer, Nylon			
34	105622X	Lever, Lift			

*STANDARD HARDWARE--PURCHASE LOCALLY

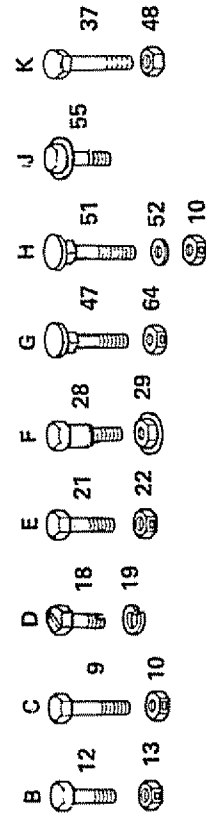

REPAIR PARTS

GT 18 TWIN GARDEN TRACTOR--MODEL NUMBER 917.255915

MOWER

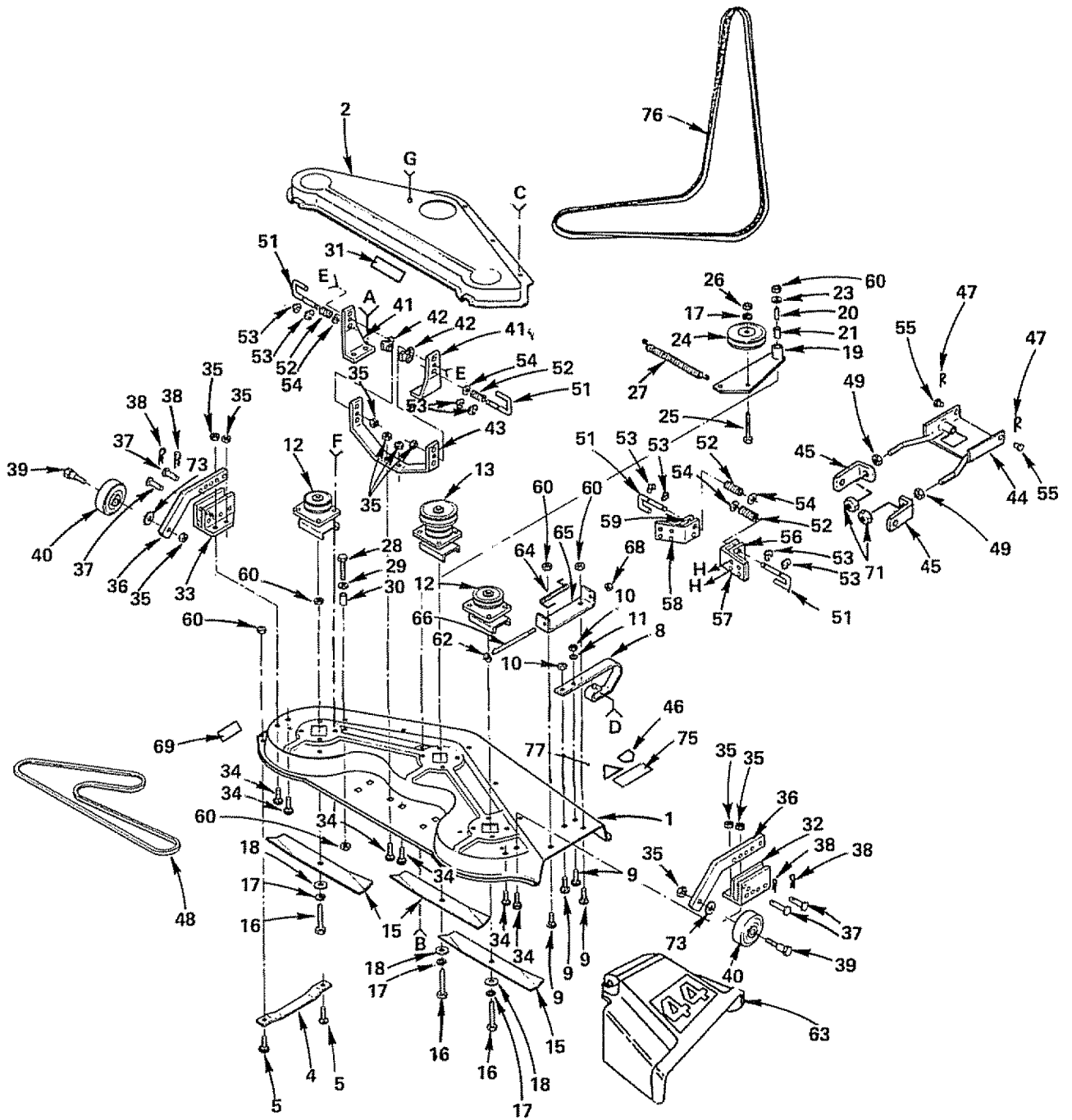

REPAIR PARTS

GT 18 TWIN GARDEN TRACTOR--MODEL NUMBER 917.255915

MOWER

KEY NO.	PART NO.	DESCRIPTION	KEY NO.	PART NO.	DESCRIPTION
1	105415X	Housing, Mower	35	73680600	Nut, Crownlock 3/8 - 16
2	106022X	Cover - Drive, Deck	36	105453X	Bar, Ga. Wheel
3	17490508	Screw - Hex Washer Thd. Roll 5/16 - 18 x 1/2	37	5565J	Pin, Clevis
4	7631J	Runner, L.H.	38	4939M	Retainer, Spring
5	72110505	Bolt, Carr. 5/16 - 18 x 5/8	39	4898H	Bolt, Shoulder
6	STD551131	*Washer-Lock, 5/16	40	105455X	Wheel, Gauge
7	STD541031	*Nut-Hex 5/16 - 18	41	105433X	Brkt., Suspension
8	8418J	Runner, R.H.	42	110237X	Spacer
9	72140506	Bolt, Carr. 5/16 - 18 x 3/4	43	105434X	Brace, Suspension
10	1685H	Nut, Lock 5/16 - 18	44	105436X	Parallel Link
11	STD551031	*Washer 11/32 x 11/16 x 16 Ga.	45	105441X	Brkt., Suspension
12	105483X	Mandrel - Secondary	46	78850	Decal - Warning
13	106038X	Mandrel - Primary	47	3146R	Retainer - Spring
14	17490612	Screw - Hex Washer Thd. Roll 3/8 - 16 x 3/4	48	106381X	V-Belt
15	106635X	Blade	49	STD541050	*Nut, 1/2 - 13
16	STD623715	*Bolt - Hex, 3/8 - 24 x 1 - 1/2 Gr. 5	50	74760622	Bolt, Hex 3/8 - 16 x 1 - 3/8
17	STD551137	*Washer-Lock, 3/8	51	105435X	Pin, Release
18	19132012	Washer 13/32 x 1 - 1/4 x 12 Ga.	52	3720R	Spring
19	674A213	Arm Assembly, Idler	53	12000039	Ring, Klip
20	7834J	Liner, Bearing	54	19171612	Washer 17/32 x 1 x 12 Ga.
21	7835J	Bearing	55	105440X	Pin, Clevis
22	72110522	Bolt, Carriage 5/16 - 18 x 2 - 3/4	56	105456X	Brkt., Outer, R.H.
23	19111610	Washer 11/32 x 1 x 10 Ga.	57	105460X	Brkt., Inner, R.H.
24	102403X	Pulley, Idler	58	105461X	Brkt., Inner, L.H.
25	STD523715	*Bolt - Hex 3/8 - 16 x 1 - 1/2	59	105457X	Brkt., Outer, L.H.
26	STD541037	*Nut - Hex 3/8 - 16	60	73680500	Locknut 5/16 - 18
27	104361X	Spring	62	19111016	Washer 11/32 x 5/8 x 16 Ga.
28	STD523112	*Bolt - Hex 5/16 - 18 x 1 - 1/4 Gr. 5	63	109785X	Shield, Deflector
29	19111216	Washer 11/32 x 3/4 x 16 Ga.	64	106734X	Spring, Deflector
30	8438J	Spacer	65	109743X	Bracket, Deflector
31	106224X	Decal - V-Belt, Dr., Schematic, Mower	66	106735X	Rod, Hinge
32	105448X	Bracket, Ga. Wheel, R.H.	68	110452X	Push Nut
33	105449X	Bracket, Ga. Wheel, L.H.	69	3713J	Instruction - Caution Decal
34	STD533707	*Bolt, Carriage 3/8 - 16 x 3/4	71	73680800	Nut - Lock 1/2 - 13
			73	19171512	Washer 17/32 x 15/16 x 12 Ga.
			74	72240608	Bolt, Carriage 3/8 - 16 x 1
			75	106679X	Decal - Warning
			76	106863X	V-Belt
			77	106975X	Decal

*STANDARD HARDWARE--PURCHASE LOCALLY

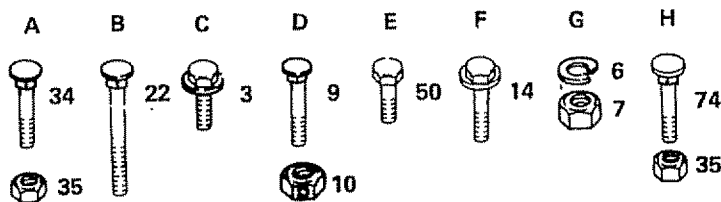

REPAIR PARTS

GT 18 TWIN GARDEN TRACTOR--MODEL NUMBER 917.255915

TRANSAXLE

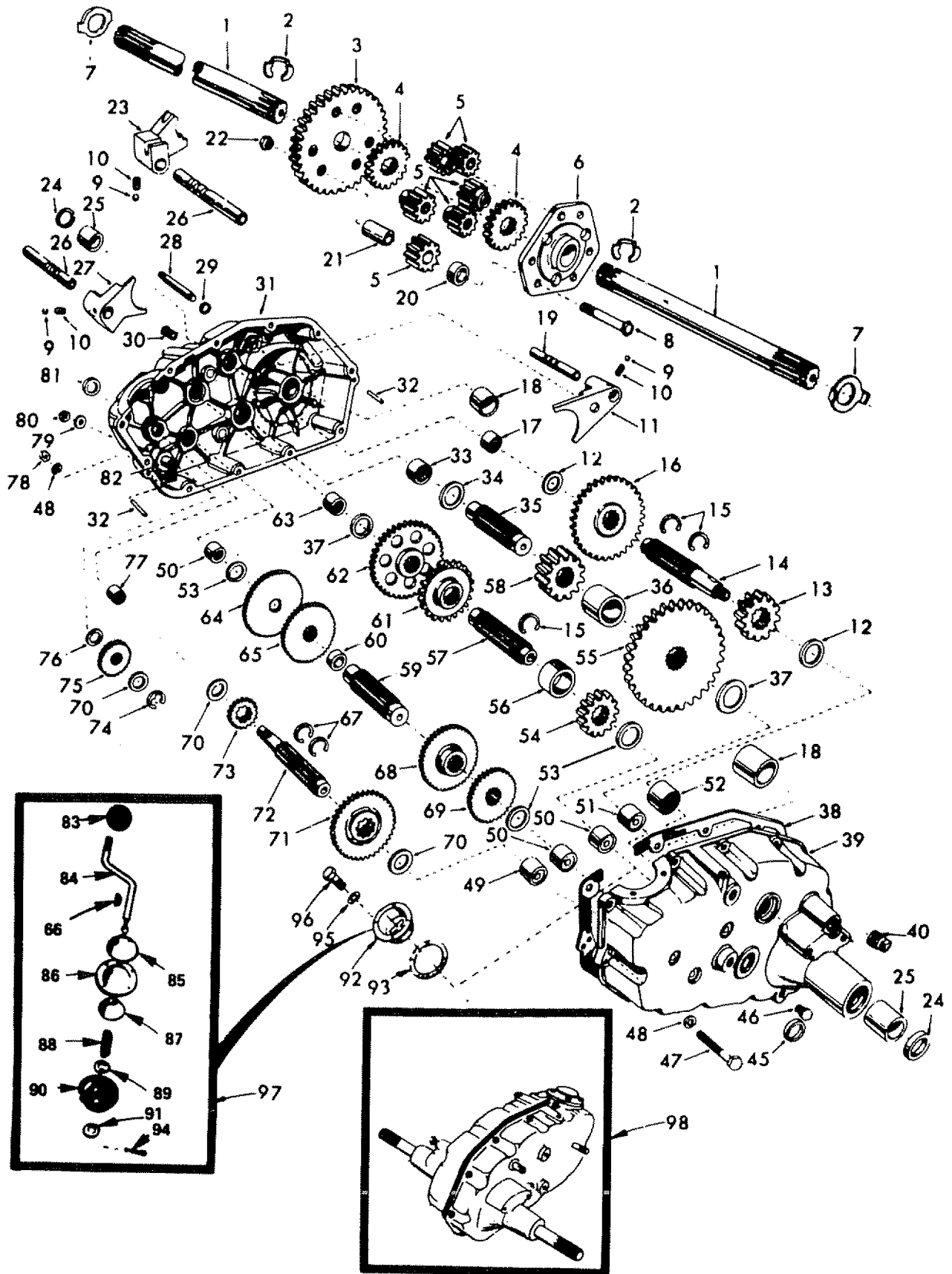

REPAIR PARTS

GT 18 TWIN GARDEN TRACTOR--MODEL NUMBER 917.255915

TRANSAXLE

KEY NO.	PART NO.	DESCRIPTION	KEY NO.	PART NO.	DESCRIPTION
1	4197R	Axle Shaft	49	4895H	Needle Bearing
2	5845R	Retaining Ring	50	4222R	Needle Bearing
3	4199R	Final Drive Gear	51	1529R	Needle Bearing
4	4216R	Differential Gear	52	8119M	Needle Bearing
5	4215R	Differential Pinion	53	4220R	Thrust Bearing Race
6	4217R	Differential Carrier	54	4209R	3rd Reduction Pinion - Low
7	6256H	Axle Thrust Washer	55	4213R	4th Reduction Gear
8	74020652	Hex Bolt 3/8 - 24 x 3 - 1/4 (1" Thread Length)	56	4442R	3rd Reduction Pinion Spacer
9	7392M	Steel Ball	57	4195R	2nd Reduction Gear Shaft
10	6272H	Spring Shift Fork Detent	58	4214R	Final Drive Pinion
11	4985R	Shift Fork, High - Low Range	59	4194R	1st Reduction Gear Shaft
12	6266H	Thrust Bearing Race	60	7528R	1st Reduction Shaft Spacer
13	4212R	4th Reduction Pinion	61	4208R	3rd Reduction Pinion - High
14	4196R	3rd Reduction Gear Shaft	62	4207R	2nd Reduction Gear
15	6276H	Snap Ring - Crescent Type	63	7398H	Needle Bearing
16	633A63	High - Low Range Gears	64	4203R	Low Speed Gear and 2nd Reduction Pinion Cluster
17	8118M	Needle Bearing	65	4204R	Reverse Gear
18	8740H1	Sintered Iron Bearing	66	2898J	Key - Hi - Pro 1/8 x 17/32
19	6217H	Shift Fork Shaft, High - Low Range	67	4926H	Snap Ring - Crescent Type
20	4218R	Differential Pinion Spacer	68	4205R	Intermediate Speed Gear
21	6252H1	Differential Pinion Bushing	69	4206R	High Speed Gear
22	7810H	Gripco Centerlock Nut 3/8 - 24	70	1370H	Thrust Bearing Race
23	4986R	Shift Fork - L.H.	71	633A69	Intermediate and High Speed Cluster Pinions
24	7393R	Oil Seal	72	208J	Input Shaft
25	992R1	Sintered Iron Bearing	73	4201R	Low Speed Pinion
26	6216H	Shift Fork Shaft	74	12000002	E-Ring
27	6262H	Shift Fork - R.H.	75	1153R	Reverse Idler Gear
28	101416X	Shift Shaft, High - Low Range	76	7392H	Reverse Idler Thrust Washer
29	6269H	Oil Seal	77	3990H	Needle Bearing
30	5855H	Pressure Relief Valve	78	STD541031	*Hex Nut 5/16 - 18
31	105406X	Gearcase, Reverse Idler Shaft and Bearings - R.H. (Inc. Key No's 17, 18, 25, 33, 50, 63, 76, 77 and 82)	79	1167R	Sealing Washer
32	6277H	Dowel Pin	80	73360700	Hex Jam Nut 7/16 - 20
33	4225R	Needle Bearing	81	6270H	Oil Seal
34	7396H	Thrust Bearing Race	82	7384H	Reverse Idler Shaft
35	4198R	4th Reduction Gear Shaft	83	100196K	Control Knob
36	4200R	4th Reduction Gear Spacer	84	5384J	Gear Shift Lever - Bent
37	7395H	Thrust Bearing Race	85	2978J	Gear Shift Cap
38	6275H	Gearcase Gasket	86	633A85	Gear Shift Ball Cover and Pin
39	105402X	Gearcase and Bearings - L.H. (Inc. Key No's 18, 25, 49, 50 (2), 51 and 52)	87	8739H1	Shift Lever Guide Ball - Keyed
40	13060400	Pipe Plug 1/2 - 14 N.P.T.	88	4924H	Spring
45	6271H	Oil Seal	89	19151516	Washer 15/32 x 15/16 x 16 Ga.
46	13020200	Pipe Plug 1/4 - 18 N.P.T.	90	8105R	Shift Mechanism Seal
47	STD523115	*Hex Bolt 5/16 - 18 x 1 - 1/2 Grade 5	91	19181511	Washer 9/16 x 15/16 x 12 Ga.
48	10140500	Lockwasher 5/16 Extra Heavy	92	75J	Gear Shift Gate and Reinforcement
			93	6274H	Shift Ball Cover Gasket
			94	76020412	Cotter 1/8 x 3/4
			95	STD551131	*Lockwasher 5/16
			96	STD523108	*Hex Bolt 5/16 - 18 UNC x 7/8
			97	633A109	Gear Shift Lever Ass'y.
			98	105474X	Transaxle Assembly Less Brake Drum & Shift Lever

*STANDARD HARDWARE--PURCHASE LOCALLY

REPAIR PARTS

GT 18 TWIN GARDEN TRACTOR--MODEL NUMBER 917.255915
ENGINE--MODEL NUMBER 422437, TYPE NUMBER 0758-01

CYLINDER, CRANKSHAFT AND ENGINE BASE GROUP

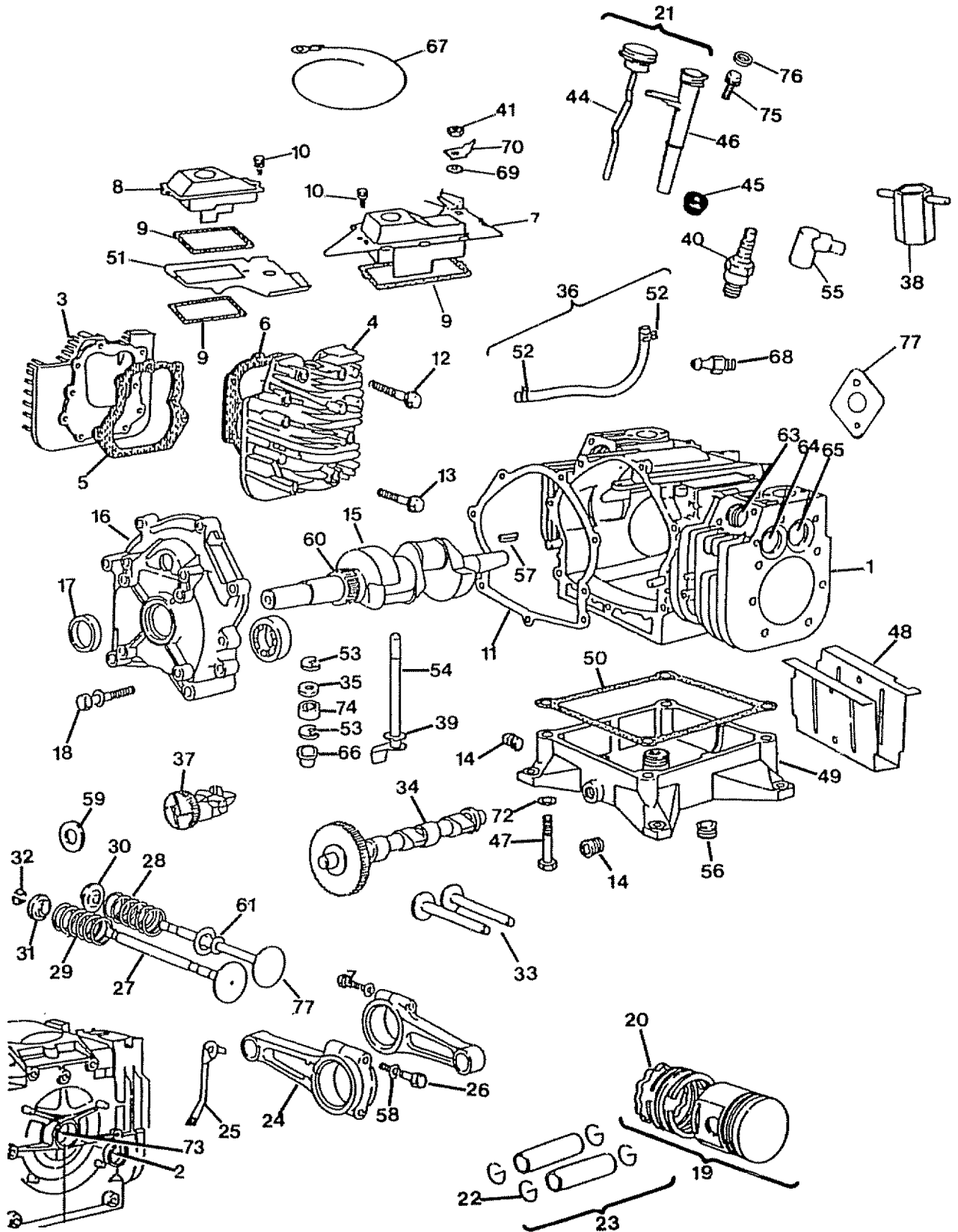

REPAIR PARTS

GT 18 TWIN GARDEN TRACTOR--MODEL NUMBER 917.255915
ENGINE--MODEL NUMBER 422437, TYPE NUMBER 0758-01

CYLINDER, CRANKSHAFT AND ENGINE BASE GROUP

KEY NO.	PART NO.	DESCRIPTION	KEY NO.	PART NO.	DESCRIPTION
01	491685	Cylinder Assembly			
02	391086	Seal-Oil	34	212337	Gear-Cam
03	212461	Head-Cylinder No. 1	35	271316	Foam Seal - Governor Shaft
04	212462	Head-Cylinder No. 2	36	296004	Pipe - Fuel 23" cut to length
05	271867	Gasket-Cylinder Head No. 1	37	394348	Gear - Governor
06	271868	Gasket-Cylinder Head No. 2	38	89838	Wrench-Spark Plug
07	393243	Breather Assembly No. 1	39	220863	Washer-Gov. Crank (inside)
08	393153	Breather Assembly No. 2	40	394539	Plug-Spark (Resistor) 12-3/8 high-60mm)
09	27803	Gasket-Valve Cover			
10	93394	Screw-Sem	41	90576	Nut-Hex 8-32
11	270982	Gasket-Crankcase Cover 1/64" Thick	42	231174	Terminal
11	271145	Gasket-Crankcase Cover .005" Thick	43	280180	Gommet - Insulator
11	271146	Gasket-Crankcase Cover .009" Thick	44	398924	Cap and Dipstick-Oil Filler
12	93113	Screw-Cylinder Head (2-5/16" long)	45	68838	Seal-Filler Tube
13	93111	Screw-Cylinder Head (1-15/16" long)	46	280220	Tube - Oil Filler
14	Plyg-Oil Drain		47	93783	Screw-Hex Hd.
15	394430	Crankshaft - order part 94196	48	223055	Trough-Dipper
		Key for retaining timing gear	49	394391	Base-Engine
16	394535	Cover Assembly - Crankcase	50	270981	Gasket-Engine Base
17	291675	Seal-Oil	51	222700	Guide Air
18	93847	Screw-Crankcase cover Mtg. Sem	52	93053	Clamp-Fuel Pipe
19	394955	Piston Assembly-Standard Inc. Key No.'s 20 & 22)	53	93851	Retainer-E-Ring
19	394956	Piston Assembly - .010" O.S.	54	394396	Crank-Governor
19	394957	Piston Assembly - .020" O.S.	55	66538	Elbow-Spark Plug
19	394958	Piston Assembly - .030" O.S.	56	93448	Plug-Hex Socket
20	394959	Ring Set - Piston - Standard	57	222698	Key-Flywheel
20	394960	Ring Set-Piston - .010" O.S.	58	220863	Washer
20	394961	Ring Set - Piston - .020" O.S.	59	222773	Washer-Thrust
20	394962	Ring Set - Piston - .030" O.S.)	60	231445	Gear-Timing
21	398990	Dipstick and Tube Assembly (Inc. Key No's. 44, 45 & 46)	61	393606	Seal Ass'y. and Retainer
22	260924	Lock-Piston Pin	62	393741	Bearing-Ball (P.T.O. side)
23	299691	Pin Assembly - Piston Standard (Inc. Key No. 22)	63	261961	Guide-Exhaust Valve
23	391286	Pin - Assembly-Piston-.005" O.S.			NOTE: 231218 Intake Valve Guide Only (Brass)
24	394306	Rod Assembly-Connecting For Connecting Rod with .020" Crankpin bore order No. 397158	64	210940	Seat-Exhaust Valve (Standard)
25	223053	Dipper-Connecting Rod	65	261463	Seat-Intake Valve (Standard)
26	92909	Screw-Connecting Rod	66	261559	Lower Bushing - Gov.
27	390420	Valve-Exhaust	67	398808	Wire-Ground
28	65906	Spring-Intake Valve	68	230318	Connector-Fuel Pipe
29	26828	Spring-Exhaust Valve	69	92791	Washer-Lock Shakeproof
30	221596	Retainer-Intake Valve	70	93722	Terminal-Spade
31	292260	Rotocoil-Exhaust	71	261528	Valve-Intake
32	93630	Retainer-Exhaust Valve Rotocoil	72	92268	Washer
33	261368	Tappet-Valve	73	191523	Bearing-Cylinder
			74	261560	Upper Bushing-Governor
			75	93886	Screw
			76	271170	Seal Tube
			77	271174	Gasket - Exhaust

*INCLUDED IN GASKET SET 394501
+SPECIAL TOOLS REQUIRED TO INSTALL



REPAIR PARTS

GT 18 TWIN GARDEN TRACTOR--MODEL NUMBER 917.255915
 ENGINE--MODEL NUMBER 422437, TYPE NUMBER 0758-01

AIR CLEANER-CARBURETOR GROUP

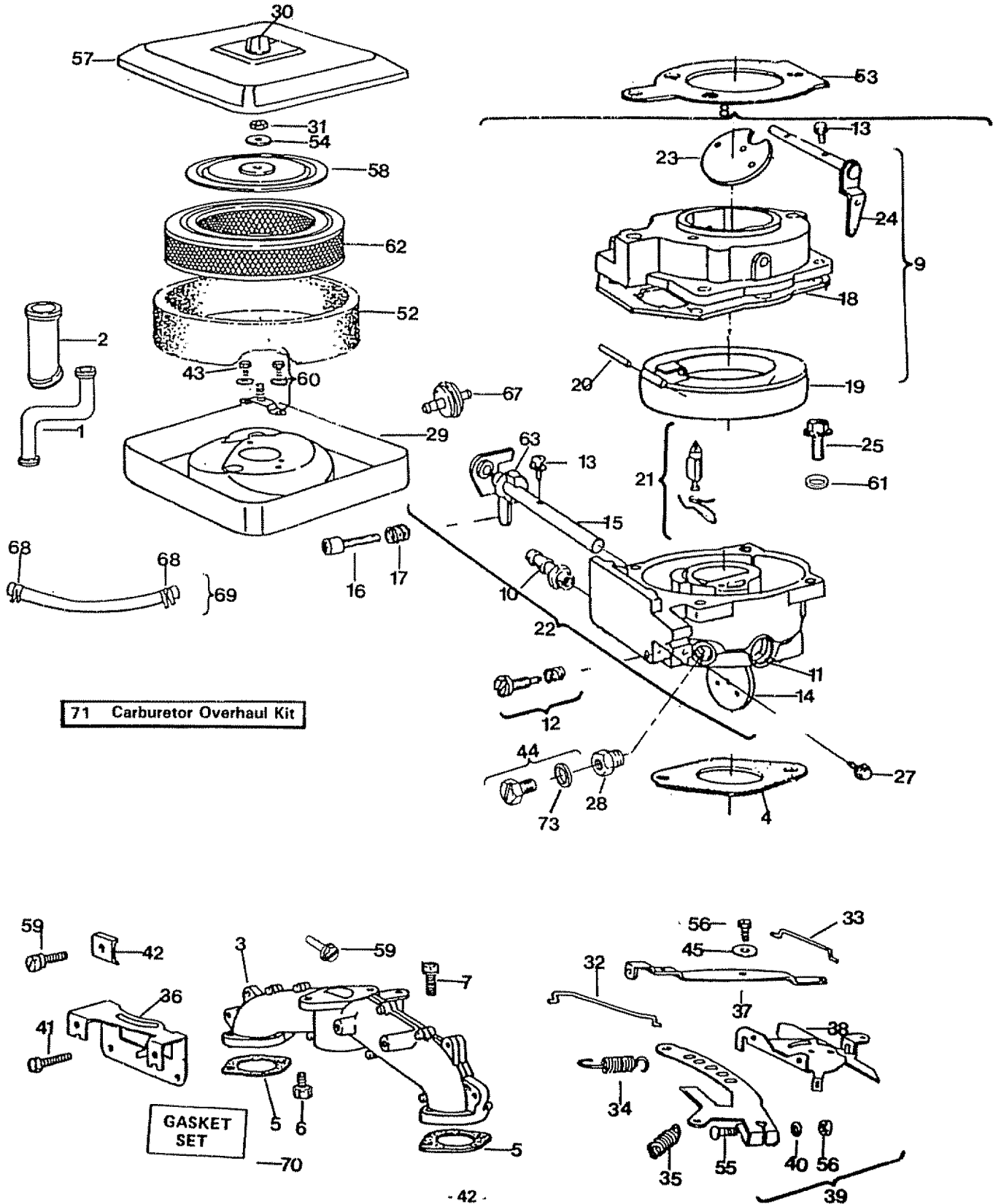

REPAIR PARTS

GT 18 TWIN GARDEN TRACTOR--MODEL NUMBER 917.255915
ENGINE--MODEL NUMBER 422437, TYPE NUMBER 0758-01

AIR CLEANER--CARBURETOR GROUP

KEY NO.	PART NO.	DESCRIPTION	KEY NO.	PART NO.	DESCRIPTION
1	280185	Tube-Breather	31	93715	Nut-Hex
2	280198	Tube-Intake	32	261444	Kink-Governor
3	212999	Manifold Ass'y Intake	33	261531	Link-Speed Control
4	271412	+ *Gasket-Carb. Mtg	34	261720	Spring-Governor
5	270884	Gasket-Intake Manifold Mtg	35	251563	Spring - Governor Idle
6	93415	Screw Carb MTG Sem	36	222807	Bracket-Speed Control
7	93208	Screw Intake Manifold Mtg Sem	37	222828	Lever-Speed Control
8	491630	Carburetor Ass'y (Inc Key No's	38	394324	Plate Ass'y Governor Control
		9. 10. 11. 12. 13. 14. 15. 16. 17.	39	393846	Lever Ass'y Governor (Inc Key
		18. 19. 20. 21. 22. 23. 24. 25.			No's 40 55 & 56)
		28. 44. 46. 47. 48. 49. 50. 51.	40	222289	Washer
		61. 63. 64 & 65	41	93163	Screw-Sem
9	91541	Body Assembly - Upper Carburetor	42	221535	Clamp-Casing
		(Inc Key No's 10 13 18 23 &	43	83893	Screw-Sem
		24)	44	397882	Plug (Inc Key No 28A)
10	230318	Connector - Fuel	45	231172	Bushing-Speed Control
11	231209	Bushing-Throttle Shaft	52	271271	Element-Air Cleaner
12	491538	+ Valve Ass'y -Carb Idle	53	271411	+ Gasket-Air Cleaner
13	93499	Screw-Throttle and Choke Valve	54	271180	Washer
		Mtg Sem	55	93853	Bolt-Governor Lever
14	221939	Valve-Throttle	56	92278	Nut-Hex
15	392672	Shaft and Lever-Throttle	57	223001	Cover-Air Cleaner
16	91920	Screw-Mach. Fil Hd 8-32 x 5/8	58	222835	Cartridge Plate-Air Cleaner
17	26157	Spring - Throttle Adj.	59	93496	Screw-Sem
18	271607	+ *Gasket-Carburetor Body	60	392643	Mounting Strap Ass'y Air Cleaner
19	298514	Float-Carburetor Body			(Inc Key No 43)
20	230896	+ Pin-Float Hinge	61	66432	Washer Plain
21	394681	+ Valve-Fuel Inlet	62	394018	Cartridge-Air Cleaner
22	491665	Body - Lower Carburetor (Inc. Key	63	271013	+ Washer-Choke Shaft
		No's 11. 13. 14. 15 & 65)	66	93828	Screw-Sem
23	223534	Valve-Choke	67	394358	Filter-Fuel
24	392673	Shaft and Lever-Choke	68	93053	Clamp-Fuel Pipe
25	94152	Screw-Hex Head Sem 10/32 x 3/4	69	393815	Fuel-Line (28") (cut to required
27	93897	Screw-Casing Clamp			length 11- 1/4)
28	231338	Jet-Needle Valve	70	394501	Gasket Set
29	222752	Body-Air Cleaner	71	491539	Carburetor Overhaul Kit
30	212706	Knob-Air Cleaner	72	223472	Plug - Welch
			73	280474	O-Ring Seal

*INCLUDED IN GASKET SET
+ INCLUDED IN CARBURETOR OVERHAUL KIT
°HIGH ALTITUDE - JET NEEDLE
VALVE - PART NO. 231333



REPAIR PARTS

GT 18 TWIN GARDEN TRACTOR--MODEL NUMBER 917.255915
ENGINE--MODEL NUMBER 422437, TYPE NUMBER 0758-01

STARTER MOTOR GROUP

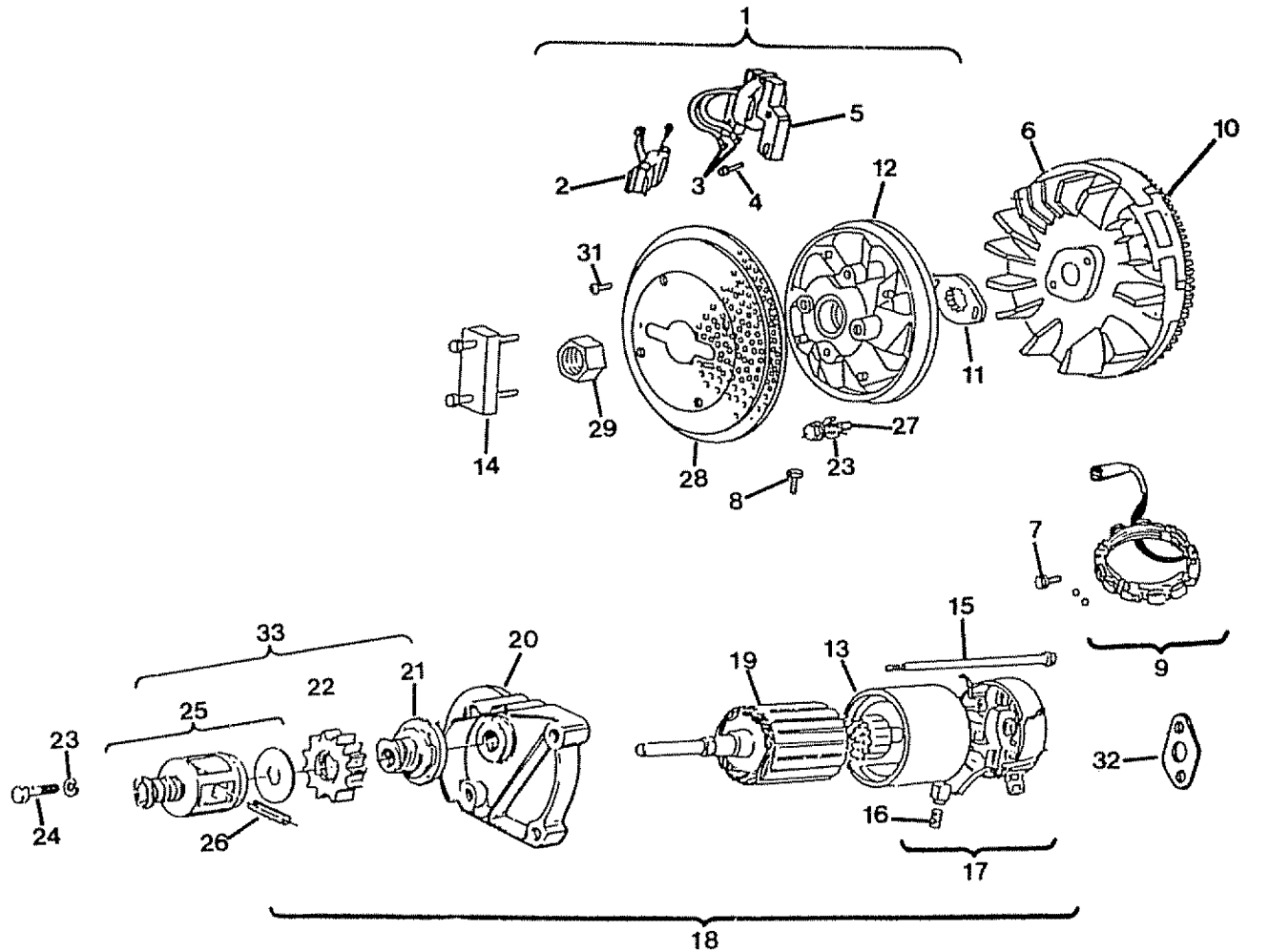

KEY NO.	PART NO.	DESCRIPTION	KEY NO.	PART NO.	DESCRIPTION
1	394891	Armature Group (Inc. Key No's 2, 3 & 5)	18	394808	Motor - Starting (Inc. Key No's. 13, 15, 16, 17, 19, 20, 21, 22, 23 & 24)
2	394970	Capsule Assembly - Magnatron® Ignition	19	390837	Amature Assembly (Motor)
3	221798	Terminal - Ignition Cable	20	394860	Drive End Cap Ass'y. - Starter
4	93381	Screw - Armature Mtg. Sem	21	391135	Clutch Ass'y.
5	394988	Armature Ass'y.	22	280104	Gear
6	392956	Flywheel and Ring Gear Ass'y.	23	90366	Lockwasher
7	93621	Screw - Sem	24	91162	Screw - Hex Hd. - 5/16 - 18 x 1 - 1/2"
8	93343	Screw-Regulator	25	393254	Kit - Pinion Spring (Inc. Key No's. 22 & 26)
9	392595	Stator - Alternator	26	93754	Roll Pin
10	391362	Gear - Flywheel Ring (Includes Mounting Parts)	27	92674	Screw - Hex Hd.
11	22906	Nut Flywheel Lock	28	223008	Screen - Rotating
12	212418	Fan - Booster	29	231247	Nut - Jam
13	393825	Housing Assembly	30	393537	Connector - Tri Circuit
14	19203	Puller - Flywheel (Optional Accessory)	31	93808	Screw-Sem
15	94003	Thru Bolt	32	271174	Gasket - Exhaust
16	395538	Brush Set	33	396865	Starter Drive Group (Inc. Key No's. 21, 22, 25 & 26)
17	395537	Commutator End Cap Ass'y. - Starter (Inc. Key No. 16)	34	393422	Alternator Harness Assembly

REPAIR PARTS

GT 18 TWIN GARDEN TRACTOR--MODEL NUMBER 917.255915

ENGINE--MODEL NUMBER 422437, TYPE NUMBER 0758-01

MUFFLER, AIR GUIDE AND HOUSING GROUP

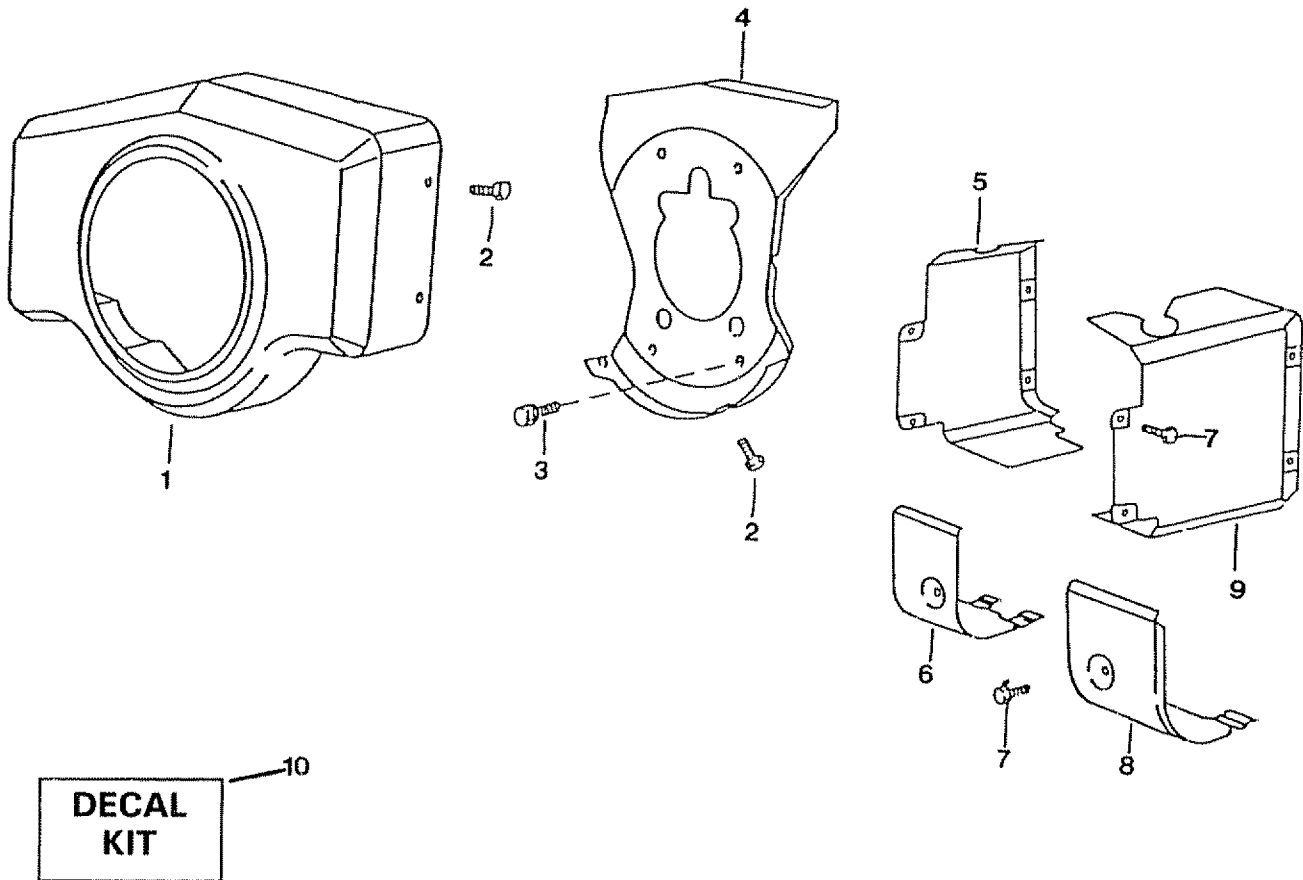

KEY NO.	PART NO.	DESCRIPTION
1	396088	Housing-Blower
2	93158	Screw - Sem
3	93777	Screw - Hex H
4	392934	Back Plate Assembly
5	222848	Cover - Air Guide
6	222846	Shield - Cylinder
7	93163	Screw - Sem
8	222847	Shield - Cylinder
9	222849	Cover - Air Guide
10	491262	Decal Kit

SERVICE NOTES



SUGGESTED GUIDE FOR SIGHTING SLOPES FOR SAFE OPERATION

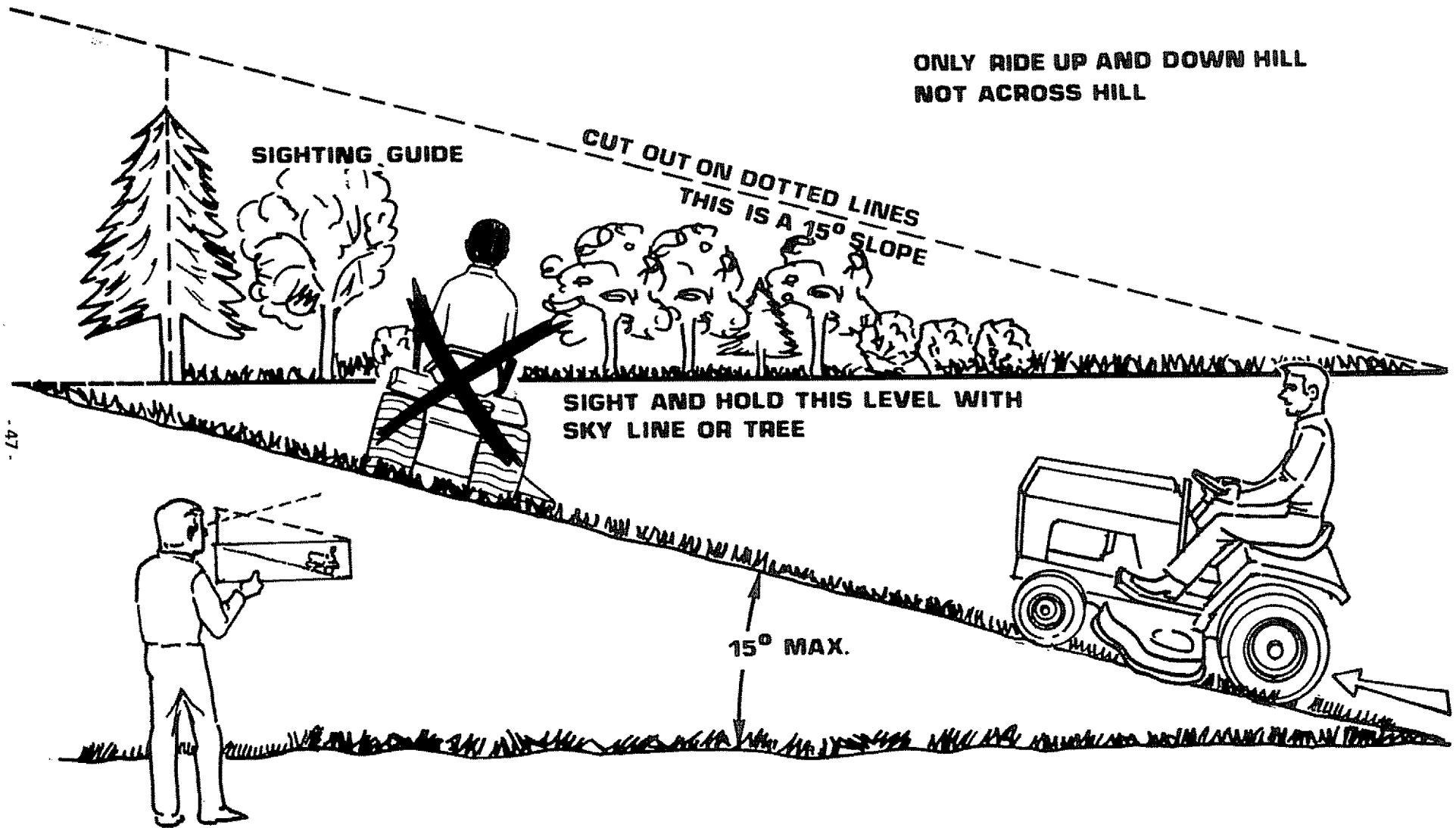

Operate your Tractor up and down the face of slopes (not greater than 15°); never across the face. Make turns gradually to prevent tipping or loss of control. Exercise extreme caution when changing direction on slopes.



SEARS

**OWNERS
MANUAL**

**MODEL NO.
917.255915**

**HOW TO ORDER
REPAIR PARTS**

GT 18 TWIN 6 SPEED GARDEN TRACTOR

The Model Number will be found on the Model Plate attached to the Fender. Always provide the Model Number when requesting service or repair parts for your Garden Tractor.

All parts listed herein may be ordered from any Sears Service Center/Departments and most Sears Retail Stores.

WHEN ORDERING REPAIR PARTS, ALWAYS GIVE THE FOLLOWING INFORMATION:

- THE PART NUMBER
- THE PART DESCRIPTION
- THE MODEL NUMBER
- THE NAME OF MERCHANDISE

Your Sears merchandise has added value when you consider Sears has service units nationwide staffed with Sears trained technicians having the parts, tools and the equipment to insure that we meet our pledge to you, "We Service What We Sell".