

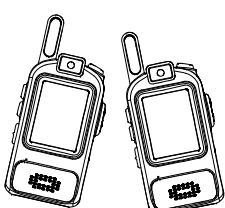

**Veenix**

**V01 WALKIE-TALKIE MANUAL**



**V01**

CONTACT US FOR MORE TECH SUPPORT  
☎ +1 (971) 391-2223 | ☎ Mon-Sun 8AM-5PM (PST)

**I. Product Overview & Controls**  
(This section identifies the main features. Refer to the product diagram for locations.)

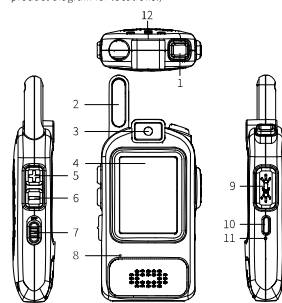

**1. Camera Mode / Voice Effect Button:**  
Short Press: Switch between the different screen views/layouts  
Long Press: Activate/deactivate fun voice change effects during a call.

**2. Antenna:** Internal antenna for a stable wireless connection and clear video transmission.  
**3. Camera:** Built-in lens for capturing and transmitting your live video.  
**4. Display Screen:** High-resolution screen for viewing the live video feed from the paired device.  
**5. Volume Up Button**  
**6. Volume Down Button**  
**7. Power Switch:** Slide to turn the device ON or OFF.  
**8. Microphone (MIC):** Internal microphone for capturing your voice during calls.  
**9. Intercom Key (PTT):** Press and hold to talk; release to listen. Press once to take a picture; double-press to open the album.  
**10. Type-C Charging Port:** For connecting the included USB-C cable to recharge the battery.  
**11. Charging Indicator Light:**  
Solid Red: Device is charging.  
Off: Battery is fully charged.  
**12. Lanyard Hole:** For attaching the included wrist strap for secure portability.

**II. Power On/Off**  
**1. Initial State:** The unit ships with its power switch in the "OFF" position.  
**2. Turning On & Connection:**  
Slide the power switch to "ON" to start the device.  
Note: The video feed from the paired unit will appear on your screen only after the other unit is also powered on.  
**3. Before First Use:** Please fully charge the device before initial use.

**III. Charging**  
**1. Charging Process:** Connect the provided USB cable to the charger. The charging indicator will light up red.  
**2. Full Charge:** The indicator light will automatically turn off once the battery is fully charged.  
**3. Charge Specifications:** Use a standard 5V/1A (or higher) USB charger.  
**4. Precaution:** Charging must be performed under adult supervision.

**IV. Function Description**  
**1. Power On & Auto-Connect:**  
Turn the power switch to "ON". The device will power on and display its own camera view on the screen.  
When the paired walkie-talkie is also powered on, the two units will automatically connect and display each other's live video feed.  
**2. Push-to-Talk (PTT) Operation**  
This device features a one-way voice transmission channel, allowing only one person to speak at a time. Please follow the steps below to communicate:  
**To Speak:** Press and hold the Intercom Key (PTT). A yellow icon will appear on the left side of the screen, indicating that your microphone is live. Speak clearly into the device.  
**To Listen:** Release the Intercom Key (PTT) after speaking. A green icon will appear on the left side of the screen, indicating that the paired device is now transmitting audio. Listen for the other party's response.

**3. Screen Display Mode**  
This device offers four different screen display layouts. Briefly press the Display Mode / Camera Switch Button to cycle through the following modes:  
**Mode 1:** Picture-in-Picture (Paired device's camera is primary)  
**Mode 2:** Picture-in-Picture (Your camera is primary)  
**Mode 3:** Full-screen view of the paired device's camera  
**Mode 4:** Full-screen view of your own camera

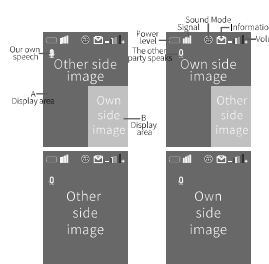

**4. Volume adjustment:**  
Short press the "+" button to increase the volume.  
Short press the "-" key to decrease the volume.

**5. Voice Changing Function**  
Press and hold the Voice Effect Button for 2 seconds to activate the feature. The on-screen voice mode icon will change to indicate activation. To return to the normal, unaltered voice mode, press and hold the same button for 2 seconds again.

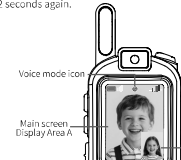

**6. Power Management & Auto-Shutdown:**  
**Standby Status:** The device remains in a low-power working state when powered on, ready for instant use.  
**Auto-Shutdown:** To prevent complete battery drain, the device will automatically shut down when the battery level becomes critically low.  
**Manual Shutdown:** To conserve battery when not in use for an extended period, manually slide the power switch to the "OFF" position.  
**Restart:** If needed, you can restart the device by sliding the power switch to "OFF" and then back to "ON".

**7. Camera Function (Photo Capture)**  
Briefly press the Intercom Key (PTT) to take a photo. The primary subject in the main display area (Area A) will be captured.  
**Storage Error:** If the message "No space left to save photo" appears, it indicates the device's internal storage is full. Please manage your photos via the Album feature.

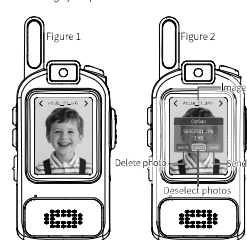

**8. Album Browsing & Management:**  
**Enter Album:** From the main screen, double-press the Intercom Key (PTT) to enter the Album.  
**Browse Photos:** In the Album, use the Volume Up (+) or Volume Down (-) buttons to navigate through your photos.

**Select & Operate on a Photo:**  
a. Navigate to a photo and briefly press the Intercom Key (PTT) to select it. A menu will appear.  
b. Use the Volume Up (+) or Volume Down (-) buttons to highlight your desired option in the menu (e.g., Cancel, Send, Delete).  
c. Briefly press the Intercom Key (PTT) again to confirm your selection.  
**Exit Album:** To return to the main screen, press and hold the Intercom Key (PTT) while in the Album view.

**9. Send and Receive Photos**  
You can share and receive photos with the paired device.  
**a. Send a Photo:**  
In the Album, navigate to the photo you wish to send (see Section 8, "Select & Operate on a Photo"). In the menu that appears, select the "Send" option and confirm.  
The photo will be transmitted to the paired device.  
**b. Receive a Photo:**  
When a photo is being sent to you, a notification icon will appear at the top of the screen, and you will hear a prompt tone.  
The received photo is automatically saved to your Album for later viewing.  
Received photos are named in the format: "Receive\_img\*" (e.g., Receive\_001.jpg).  
**Error Messages:**  
Photo Save Failed, No Space: The receiver's memory is full.  
Photo Send Failed: Poor signal (move to an open area).

**10. Product Pairing & Connection**  
**Dedicated Pairing:** Each set of walkie-talkies comes pre-paired as a dedicated pair (one-to-one).  
**Do Not Mix Sets:** Walkie-talkies from different sets cannot connect with each other. If you own multiple sets, please ensure they are stored and used separately to avoid confusion.

**11. Precautions**  
**a. Usage Environment:** This product is designed for outdoor use. Indoor performance, including the maximum reliable connection distance, is based on achieving a smooth, lag-free video image.  
**b. Water Resistance:** This device is not waterproof. Do not expose it to rain, moisture, or liquids.  
**c. Connection Range:** The effective operating range can vary significantly with the environment. Obstacles like walls will reduce the range. For best results, ensure a clear line of sight between devices.

**V. Troubleshooting**

Problem	Possible Cause	Solution
Can't turn on	Dead battery	Charge for 100mins, then retry.
No connection	Paired device off / out of range	Turn on the paired device; keep within range
Can't take photos	Memory full	Delete old photos
Auto-shutdown	Low battery	Charge immediately.

**VI. Product specifications**

Screen	2.0 Inch IPS
CMOS pixel	300000 pixels
Battery capacity	3.7V 600mAh
Language	English
USB Port	Type-C
Operate TEMP	-20°C - 60°C
Storage TEMP	-30°C - 70°C
Power	5V/1.0A
Product size	124mm*54mm*23 mm

**CE FC RoHS**  
Made in China

This device complies with Part 15 of the FCC Rules. Operation is subject to the following two conditions: (1) this device may not cause harmful interference, and (2) this device must accept any interference received, including interference that may cause undesired operation.

Changes or modifications to this unit not expressly approved by the party responsible for compliance could void the user's authority to operate the equipment.

**NOTE:** This equipment has been tested and found to comply with the limits for a Class B digital device, pursuant to Part 15 of the FCC Rules. These limits are designed to provide reasonable protection against harmful interference in a residential installation. This equipment generates uses and can radiate radio frequency energy and, if not installed and used in accordance with the instructions, may cause harmful interference to radio communications. However, there is no guarantee that interference will not occur in a particular installation. If this equipment does cause harmful interference to radio or television reception, which can be determined by turning the equipment off and on, the user is encouraged to try to correct the interference by one or more of the following measures:  
- Reorient or relocate the receiving antenna.  
- Increase the separation between the equipment and receiver.  
- Connect the equipment into an outlet on a circuit different from that to which the receiver is connected.  
- Consult the dealer or an experienced radio/TV technician for help.

This device and its antenna(s) must not be co-located or operation in conjunction with any other antenna or transmitter.

**Radiation Exposure Statement**  
The device has been evaluated to meet general RF exposure requirement in portable exposure condition without restriction.

**Veenix**  
veenix.com

CONTACT US FOR MORE TECH SUPPORT  
☎ +1 (971) 391-2223 | ☎ Mon-Sun 8AM-5PM (PST)

veenixtoy@gmail.com

