

Kelvinator 

Heat Pump Hot Water System
User Manual



Congratulations

Congratulations and thank you for choosing our Heat Pump hot water system. We are sure you will find your new hot water system a pleasure to use. Before you use the hot water system, we recommend that you read through the entire user manual, which provides the description of the hot water system and its functions.

Just a little preventative care on your part can save you a great deal of time and money over the life of your hot water system. You'll find many answers to common problems in the chart of troubleshooting tips. If you review the chart of Troubleshooting Tips first, you may not need to call for service.

To avoid the risks that are always present when you use an appliance, it is important that the hot water system is installed correctly and that you read the safety instructions carefully to avoid misuse and hazards.

We recommend that you keep this user manual for future reference and pass it on to any future owners.

After unpacking the hot water system please check it is not damaged. If in doubt, do not use the hot water system but contact your local Electrolux Customer Care Centre.

Meanings of symbols used in this manual are shown below:



warning

This symbol indicates information concerning your personal safety



caution

This symbol indicates information on how to avoid damaging the hot water system



environmental tips

This symbol indicates tips and information about economical and ecological use of the hot water system



environmental tips

Information on disposal for users

- Most of the packing materials are recyclable. Please dispose of those materials through your local recycling depot or by placing them in appropriate collection containers.
- If you wish to discard this hot water system, please contact your local authorities and ask for the correct method of disposal.

Contents

Important safety instructions	3
Components and specifications	5
Information required to claim your STCs	5
How your hot water system works	6
Using your hot water system	6
Maintenance	8
Troubleshooting	10
Warranty	11

Conditions of use

This appliance is intended to be used in household and similar applications such as :

- staff kitchen areas in shops, offices and other working environments.
- farm houses.
- by clients in hotels, motels and other residential type environments.
- bed and breakfast type environments

Important safety instructions

warning

- Contact an authorised installer for installation of this hot water system.
- Contact an authorised service technician for repair or maintenance of this hot water system.
- Installation work must be performed in accordance with national standards by suitably licensed installers only. Wrong connection can cause over heating or fire.
- This hot water system should be installed in accordance with AS/NZS 3000 and your electricity suppliers rules.

For the installer

The installation must be done in accordance with the information supplied in the installation manual supplied with the hot water system.

All other relevant National, State or Local regulations must also be conformed with and these include (but are not limited to):

- Australian Standard AS/NZS3500.1 - Water Supply
- Australian Standard AS/NZS3500.4 - Hot Water Supply
- Australian Standard AS/NZS3000 - Electrical Installations







warning

This heat pump hot water system is approved for connection to either continuous tariff or extended off peak tariff only (also referred to as off peak 2 tariff where there may be approximately 19 hours of power available per day). This heat pump is NOT suitable for connection to night rate tariff power supply (also referred to as off peak 1 where there may be approximately 8 hours of power available per day). Connecting to night rate power supply may cause the automatic sanitisation function to not always comply with Australian Standard AS 3498 for legionella control.

warning

This hot water system delivers water in excess of 50°C. Water temperatures above 50°C can cause severe burns, scalding or death. Feel the water temperature before bathing or showering. Do not leave children unsupervised. Under AS/NZS 3500 the temperature of the hot water being delivered must not exceed 50°C at any outlets used primarily for purposes of personal hygiene. To comply with these standards, a tempering valve set (supplied) must be fitted to this hot water system.

warning

	Do not operate or stop the hot water system by switching on or off the power
	Do not use a damaged or unspecified power supply cable
	Do not allow water to run into electric parts of the hot water system as it may cause failure or electric shock
	Do not open any part of the hot water system during operation as it may cause electric shock
	Do not store flammable gas or combustibles such as gasoline, benzene, paint thinner etc near the hot water system as this may cause corrosion or an explosion
	Do not disassemble or modify the hot water system as it may cause failure and electric shock

Important safety instructions

Ensure the following safety instructions are read and understood before using this hot water system.

warning

- Do not use this hot water system if it has at any stage been immersed in water. Immediately call a licensed plumber, gas fitter or authorised technician to inspect and/or service the system.
- In order to avoid electric shock, fire or injury, if any abnormality is detected, such as the smell of smoke coming from the hot water system, isolate the power at the main switchboard then contact your local Electrolux Customer Care Centre.
- Do not insert fingers, rods or other objects into the air inlet or outlet of the heat pump. If the fan is rotating, it may cause personal injury or damage.
- Do not remove any guards or panels on the heat pump. It may cause a safety hazard or allow the unit to be damaged.
- Do not touch the heat exchanger fins. These fins are sharp and could result in cutting injuries.
- Never use a flammable spray such as hair spray, lacquer or paint near the hot water system as it may cause a fire.
- If the heat pump has been installed on a stand or wall brackets, periodically check the stand, brackets and fittings. If damaged or loose, the heat pump may fall and result in injury.
- The operation of the thermal cut out (located on the storage tank thermostat) indicates a possibly dangerous situation. Do not reset the thermal cut out until the water heater has been serviced by a qualified person.
- If power to the hot water system has been turned off for an extended period of time e.g. holidays, prolonged blackout or maintenance, it is recommended that the auxiliary heating boost function be activated once power is available. This will ensure that the hot water is sufficiently sanitised for household usage.

caution

- Do not use the hot water system for any other purposes besides heating water for domestic use.
- Do not place items which might be damaged by moisture around the hot water system or near the drain outlets.
- If a power cable is damaged, it must be replaced by an Electrolux service agent or qualified persons in order to avoid a hazard.
- This appliance is not intended for use by persons (including children) with reduced physical, sensory or mental capabilities, or lack of experience and knowledge, unless they have been given supervision or instruction concerning use of the appliance by a person responsible for their safety. Children should be supervised to ensure that they do not play with the appliance.
- Water may drip from underneath the heat pump or from the heat pump condensation discharge pipe (if installed) during its heating cycle. Ensure that this water is drained to a suitable location, away from the footings of a building.
- Water may drip from the discharge pipe of the pressure relief valve. This pipe must be left open to atmosphere at all times.
- The pressure-relief device is to be operated regularly to remove lime deposits and to verify that it is not blocked.
- A discharge pipe connected to the pressure-relief valve is to be installed in a continuously downward direction and in a frost-free environment.
- If the heat pump is installed in a location that has the potential to drop below freezing point, the heat pump must be installed on continuous power supply only and the power supply must be connected at all times. The freeze protection system only works when power is connected to the heat pump and the warranty may be void if the heat pump is damaged as a result of freezing when there was no power available.

Your heat pump hot water system components (please tick)

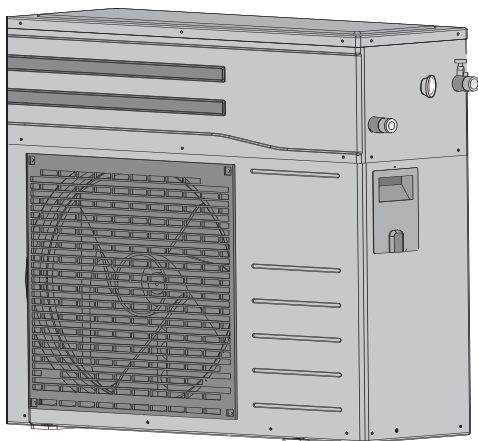

Heat Pump KSE362HPCA

- Continuous power supply
- Extended off-peak (off peak 2) power supply

When calling the service centre, please refer to this section of the user manual as it will help you to describe your heat pump hot water system and assist you in quoting the model numbers.

Refer to the rating labels on each product in order to find and record their individual serial numbers. The system model number required to claim your STC's (Small-scale Technology Certificates) can be found by referring to the table on this page.

System model number: _____

Heat pump serial number: _____

Storage tank serial number: _____

Installation date: _____

Installed by: _____

Notes: _____

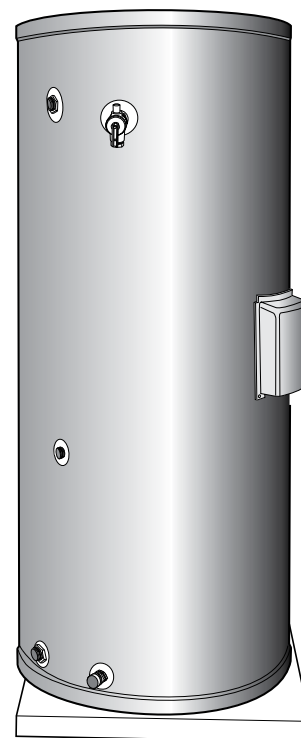

Hot water storage tank

- 270L (KCT27036A)
- 270L (KCT27036B)
- 340L (KCT34036A)
- 340L (KCT34036B)
- 425L (KCT42536B)

System model number required to claim your STCs

Heat pump model no.	Tank model no.	Power supply	System model no. for claiming STCs
KSE362HPCA	KCT27036A	Continuous	KHPE270362A-C
		Off peak 2	KHPE270362A-OP2
	KCT27036B	Continuous	KHPE270362D-C
		Off peak 2	KHPE270362D-OP2
	KCT34036A	Continuous	KHPE340362A-C
		Off peak 2	KHPE340362A-OP2
	KCT34036B	Continuous	KHPE340362D-C
		Off peak 2	KHPE340362D-OP2
	KCT42536B	Continuous	KHPE425362D-C
		Off peak 2	KHPE425362D-OP2

How your hot water system works

Your hot water system contains two main components – a heat pump and a hot water storage tank:

Heat Pump

The heat pump is the primary heating device and employs the same heating technology as a refrigeration style air conditioner. The heating operation works by taking heat energy from the surrounding air and then transferring the heat energy into water circulating from the hot water storage tank. Since this energy is not created but simply moved and concentrated from one location to another, it is a very efficient and cost effective when compared to a common electric hot water service.

Hot Water Storage Tank

The hot water storage tank is where the hot water is stored and kept available for use throughout the day. It comprises of an enamel coated steel preservation tank, surrounded by a thick layer of thermal insulation and protected by an outer metal casing. A sacrificial anode is installed inside the tank to protect it from corrosion as well as an electric element, controlled by a thermostat, which can be used as an auxiliary heating device. Depending on the installation your storage tank will have the storage capacity of either 270, 340 or 425 litres.

Operating modes

The hot water system has two operating modes, automatic mode and electric heating manual mode:

1. Automatic mode: This is the default operating mode. The heat pump starts up and shuts down according to the water temperature inside the storage tank. When the temperature inside the tank drops below the restart temperature setpoint, the heat pump will start up automatically. When the temperature inside the tank reaches the required temperature setpoint, the heat pump will stop automatically.
2. Electric heating manual mode: When the auxiliary heating boost button is pressed, the heat pump operation will change to the electric heating manual mode. During this mode the heat pump will not operate, instead outputting power to a heating element inside the storage tank. This heating element will maintain the water temperature inside the tank according to the thermostat setting (factory pre-set to 60°C). The electric heating manual mode will operate for up to a one day period before the heat pump automatically reverts back to its normal automatic mode (no resetting required). This mode can be useful when wanting to quickly boost the temperature of the water inside the tank or in the unlikely event that the heat pump requires a service call, ensuring hot water will always be available when required.

NOTE: Electric heating manual mode can only be activated by manually pressing the boost button on the heat pump. The heat pump will never automatically change over to this mode, even if a fault situation occurs. In this way you will always be aware and able to identify when something has happened to the heat pump that requires attention and there will be no unpleasant surprises on the next electricity bill.

Using your hot water system

The auxiliary heating boost button is located on the side of the heat pump near the inlet and outlet water connections.

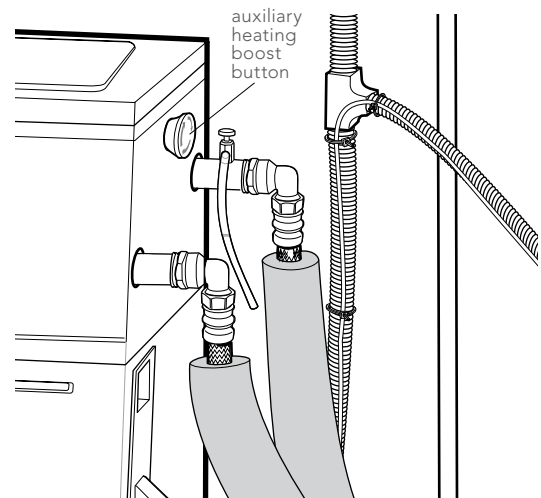

To activate the electric heating manual mode:

- Twist clockwise to release the button (if already in pushed in position), wait a few seconds then push the button until it clicks into place.
- The fan may start up if needed to keep the heat pump circuitry and electronics cool
- After a couple of seconds a “click” sound may be heard inside the heat pump and the storage tank element circuit will be activated.
- The storage tank element circuit will stay activated for up to a 1 day period, after which the heat pump will deactivate the element circuit and revert back to its normal operating mode (even when the button remains depressed).

Continuous or off-peak power supply

The heat pump may be installed on a continuous only power supply, or with an extended off-peak supply to power the compressor circuit and continuous supply to power the electronics and tank element. If the heat pump is installed on a continuous only power supply, the compressor will operate at any time of the day as required. If the heat pump is installed on extended off-peak power supply, the compressor will operate as required only when the extended off-peak power supply is available.

The heat pump is designed to operate on extended off peak (or off peak 2) which provides power for approximately 18 hours per day. If the premises only has standard night rate off peak (or off peak 1) which provides power for approximately 8 hours per day, then there is a possibility that the customer may not have sufficient hot water in the late afternoon, and the automatic weekly sanitisation function may not always work in accordance to Australian Standard AS3498 for Legionella control. Failure to follow this requirement is considered an installation error, and hence resulting complaints may not be covered under warranty. Please contact your electricity supplier to confirm or change to extended off peak power supply as required.

Using your hot water system

Water temperature operating range

The heat pump has been designed to achieve maximum efficiency and reduce greenhouse gas emissions. It maintains the water inside the storage tank between 47°C and 60°C, these temperature settings can not be modified by the installer or customer. While this may be less than the temperature setpoint of previously installed hot water systems, it is still well above showering temperature. A tempering valve has been supplied and installed with the hot water system as an important and required safety measure. If a tempering valve wasn't previously installed this may create a noticeable difference to the temperature or pressure of the hot water at the fixtures. To maximise the amount of hot water available and to save water it is recommended to install and use 3 or 4 star WELS rated showerheads (previously called AAA rated).

Bacteria and Legionella control

Once a week the heat pump will operate at a higher set point and heat water up to 60°C. This function protects your household by sanitising the water inside the storage tank to prevent Legionella and other bacteria from causing a health hazard. The heat pump will operate on this higher set point for up to 24 hours and then revert back to the normal set point for the remainder of the week. By default the heat pump starts up in this sanitisation function for added safety, and as such the weekly cycle will be reset if the heat pump continuous power supply is switched off and on.

Ambient temperature range of the heat pump

In order for the heat pump to operate correctly, the ambient temperature should be between -7°C and 50°C. If the ambient temperature is outside this range the heat pump may not operate.

Fan speed during heat pump's heating operation

During the heat pump's heating operation, the fan speed will vary according to the outdoor ambient temperature and may even stop completely. This optimises the performance of the heat pump heating operation and is part of its normal operation.

Heat pump freeze protection

The heat pump is suitable for use in frost conditions, however in order for the freeze protection mechanism to operate there must be power available to the heat pump. For this reason, when installed in location where frost can occur the heat pump MUST be installed on continuous only power supply. If the heat pump is to be without power for a long period of time due to power failure, maintenance or periodic shut down and there is a risk of frosty conditions, the heat pump could become damaged due to freezing. Follow the instructions in this manual to isolate and drain the hot water system in order to protect it from being damaged due to freezing. If it is suspected that the heat pump has become frozen, ensure that power is available and then call a service technician to inspect it. Resulting freeze damage may not be covered under warranty if the above requirements are not followed.

Periodic shut down of the hot water system

If power is to be switched off to the hot water system for extended periods of time due to non usage or maintenance of the hot water system, it is recommended that the system be drained of water to prevent damage due to freezing. Follow the instructions on page 8 of this manual to safely drain and then re-fill the hot water system as required.

Water quality

Water quality can vary in different locations and affect the performance and safe operation of the hot water system. If the water quality is not within the acceptable limits as indicated on this page, the hot water system should not be installed and may not be covered by the Electrolux warranty.

A suitable solution is to implement a water pre-treatment process (e.g. a water softener) to bring the water quality to within acceptable limits to support the installation.

The saturation index (SI) is a measure of the corrosive or scaling properties of the water supply. Corrosive water (SI<-1.0) can corrode copper components. In these conditions the warranty may not apply. Scaling water (SI>0.5) can cause build up of CaCO₃ (Calcium carbonate) which can impact to the correct operation of moving parts within the system, including the temperature and pressure relief valve. In these conditions the warranty may not apply.

Total Dissolved Solids (TDS) and water hardness can also impact the life of the hot water system, and warranty does not apply outside the following limits:

- TDS exceeding 600 p.p.m
- Electrical conductivity exceeding 850us/cm
- Total hardness exceeding 200 p.p.m
- Chloride exceeding 250 p.p.m
- Magnesium exceeding 10 p.p.m
- Sodium exceeding 150 p.p.m
- Acidity/Alkalinity must also be within the limits of pH 6.5 - 8.5

Heat pump protection devices

The heat pump is programmed to prevent unsafe conditions occurring and to protect itself from damage. When power is applied to the heat pump it will not start until it has several minutes of uninterrupted power supply to protect it from excessive cycling of the power supply. The heat pump may stop operating and become locked out due to a fault if some of the following occur:

- Air inlet or outlet is blocked
- Water inlet or outlet is blocked
- Air mix in water or refrigerant
- Refrigeration circuit pressure is too high
- Supply voltage is outside the accepted range
- Temperature sensor has been damaged or removed from storage tank
- Temperature sensors inside heat pump become faulty or damaged

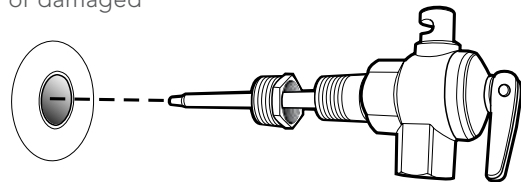

Temperature and Pressure Relief valve (TPR valve)

A temperature and pressure relief valve has been installed at the top of the storage tank to the right of the outlet connection. It is essential to the safe operation of your hot water system and may activate if an unsafe condition arises. The relief valve is designed to allow a small amount of hot water to discharge during heating to allow for hot water expansion. Over the course of a day this could add up to a few litres but if it continually leaks when the heat pump is not operating it may need to be checked and gently operated.

Running out of hot water

If you find you are occasionally running out of hot water, it may be wise to review your household's hot water usage. Since this hot water system is designed as an energy saving appliance, you should consider adjusting your water usage accordingly. Install more efficient appliances e.g. washing machines or dishwashers and water saving fixtures e.g. 3 or 4 star WELS rated showerheads. If the number of people in the household has increased, consider installing a larger capacity storage tank or changing the power supply from extended off peak to continuous.

Maintenance

Maintaining your hot water system

Regularly inspect the air inlet and outlet of the heat pump. Remove any foreign objects or blockages to allow the air to flow freely.

Once the hot water system is in use, sediment can accumulate in the system.

In order to maximise the life of the hot water system, it is recommended that you flush the system every 5 years (more frequently in poor water quality areas) according to the below instructions:

Drainage or flushing of tank

To flush or drain the storage tank:

1. The power to the hot water system must be turned off at the switchboard. Locate and turn off the circuit breaker that supplies the hot water system.

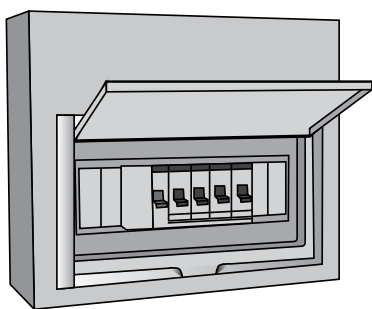

2. The water inside the tank may be very hot. Turn on the nearest hot water tap and allow it to run until the water coming out has reached a safe temperature for draining.

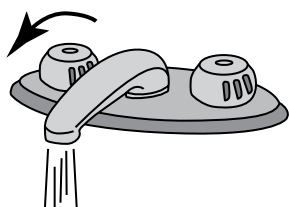

3. Before draining the hot water system assess the best area for the water to be directed (i.e. an outside drain) where it will not damage property or cause an unsafe situation to arise.
4. Turn off the mains water supply to the hot water system using the isolation valve located on the inlet piping.

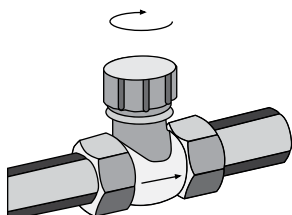

5. Release the pressure inside the tank by lifting up the lever on the pressure and temperature relief valve. Caution should be taken so the lever does not snap back as it could damage the valve seat. Once the lever is activated water will be discharged from the relief valve drainage pipe, relieving the pressure inside the storage tank.

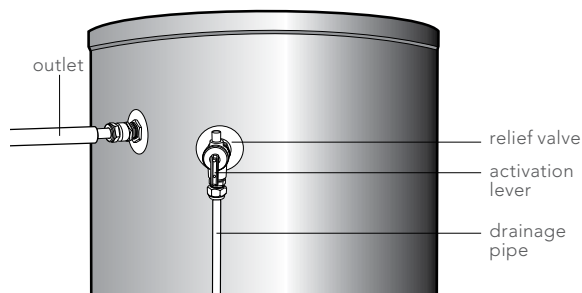

6. When water has stopped discharging from the relief valve drainage pipe, this indicates that the pressure inside the tank has now been reduced to atmospheric pressure. De-activate the lever on the relief valve, returning it to its normal position.
7. Drain the storage tank by undoing the connection to the tank inlet and placing your drainage solution in position as needed. Activate the relief valve lever, releasing the vacuum and allowing air to flow into the tank as the water drains out. Whilst the storage tank is draining, continually monitor the process and most importantly where the water is draining to. If at any time the draining needs to be halted, simply de-activate the relief valve lever.
8. Once the storage tank has been fully drained, flush the system by inserting a garden hose into the inlet of the storage tank. Allow water to enter the inlet and drain several times to ensure that all sediment is removed.
9. De-activate the relief valve, returning it to its normal position.
10. Reconnect the inlet piping to the storage tank and then turn on the isolation valve, located on the inlet piping to allow mains water to refill the tank.

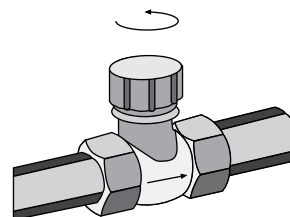

11. Turn on the nearest hot water tap to allow air to be expelled from the system. Once water has begun to flow freely from the tap for a period of time and all air has been expelled from the system, close the hot water tap.

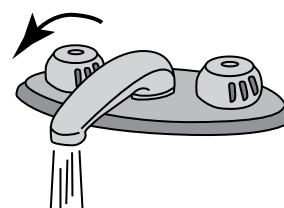

Maintenance

- Air needs to be bled from the heat pump water lines to ensure the circulating pump can operate effectively. First ensure the drainage tube connected to the small drain valve on the circulating water outlet connection is pointing away from any electrical components. Bleed air from the water lines by twisting the knob on the valve anti-clockwise. Once water has begun flowing freely from the drainage tube for 10 seconds or more, twist the knob clockwise to stop the valve from draining.

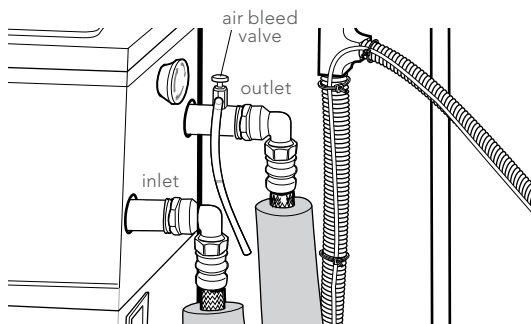

- Clean all filters in the hot water system including the tempering valve filters, and any filters that may be located on individual fixtures as they may have become blocked by debris during the process of flushing and draining of the hot water system.
- Check that all isolation valves that are designed to be open during normal operation of the hot water system are fully open. The tank **MUST** be full of hot water before turning the power back on.
- The power to the hot water system can now be turned on at the switchboard.

Note: Since the water inside the storage tank will now be cold, it may take some time for the water to return to its optimum operating temperature. If hot water is needed within 2-4 hrs, activate the electric heating manual mode to produce the hot water more quickly (see page 6 for details).

Temperature and Pressure Relief valve (TPR valve)

The valve easing gear on the relief valve must be operated gently at least once every 6 months. We recommend that this relief valve be checked regularly to ensure it is not continually leaking or that the discharge piping connected to the valve is not blocked. If the valve continually leaks when the heat pump is not operating, carefully operate the easing lever as described in step 5 on the previous page. If the valve continues to leak it is recommended to get it inspected and replaced by an authorised person.

warning

Failure to operate the relief valve easing gear at least once every six months may result in the hot water storage tank failing or in extreme cases exploding. Continuous leakage of the water from the valve may indicate a problem with the hot water system.

Anode replacement

Inside the storage tank is a sacrificial anode designed to protect the vitreous enamel coated steel tank from corrosion. The anode will slowly oxidise while protecting the steel tank liner, reducing its effectiveness in protecting the tank from rusting over time.

The anode must therefore be inspected and replaced (as required) every 2 to 5 years depending on the supply water quality, in order to keep the storage tank warranty valid. The anode inspection and replacement must be conducted by an authorised service person or plumber and be replaced by a manufacturer authorised spare part, which can be sourced from the Electrolux spare parts division (see contact details in warranty section).

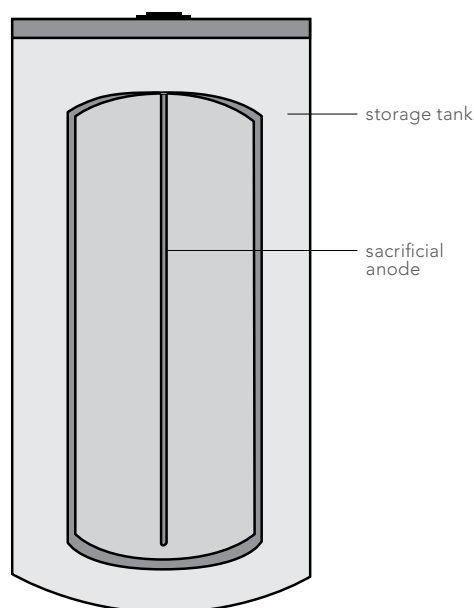

warning

If the hot water system is not used for two weeks or more, a quantity of highly flammable hydrogen gas may accumulate in the water heater. To dissipate this gas safely, it is recommended that a hot tap be turned on for several minutes or until discharge of gas ceases. Use a sink, basin, or bath outlet, but not a dishwasher, clothes washer, or other appliance. During this procedure, there must be no smoking, open flame, or any electrical appliance operating nearby. If hydrogen is discharged through the tap, it will probably make an unusual sound as with air escaping.

Note: For the purposes of the above warning, "water heater" is referring to the hot water storage tank which may also act as a water heater when the electric heating manual mode is activated via the boost button.

Troubleshooting

Before calling for servicing or repair, check the following points:

Operation	Problem	Possible solutions
Part of normal operation	The heat pump is not running	The temperature inside the tank could be above the set point and the unit has shutdown. When the temperature drops below the set point, the unit will start automatically and begin to heat the water again.
		Under colder conditions the heat pump may shutdown in order to go into defrost mode.
		If the heat pump is wired up to an off-peak tariff it will only run when this supply is available.
		The heat pump will not operate until it has 3 minutes of uninterrupted power supply as part of its protection.
	The heat pump is running but the water is cold	If this heat pump hasn't been on for long it will take some time (allow 4-6 hours) for the temperature inside the tank to get to its set-point level. If the heat pump is working correctly the output connection on the heat pump should be warm, indicating that it is pumping warm water into the tank.
		If the heat pump is installed on off peak, check with your power provider that you are on extended off peak or off peak 2 tariff. This appliance is not designed for installation on standard off peak or off peak 1.
	The fan is not running but the rest of the heat pump is	The fan speed varies according to the ambient temperature and may stop entirely during operation for a period of time. If the fan stops indefinitely while the rest of the heat pump is operating, please call a service technician.
	Boost element in storage tank is not operating	Power must be available to the heat pump for it to change to electric heating manual mode. Check that the circuit breaker is switched on.
Small amount of water leaking from underneath heat pump or installed drainage pipe	Water may collect in the bottom tray of the heat pump due to rain or condensation as part of the normal operation of the heat pump. There is a drain hole on the bottom tray of the heat pump that allows water to run out from underneath it and a drainage pipe may be connected to this hole as part of the installation. If an excessive amount of water is coming from this hole/drainage pipe or anywhere else on the heat pump please call a service technician.	
The sound of water flow inside the heat pump	This is caused by the refrigerant and water flowing inside the heat pump. It may be louder during the first few minutes of operation and is normal.	
Short 'hissing' sound coming from the heat pump	This is made by the heat exchanger as the temperature changes inside. The heat expands and the cold contracts creating an audible 'hiss' sound. This is part of normal operation and not a product fault.	
Abnormal operation	Water is discharging from the pressure relief valve on the storage tank	A small amount of water may discharge from the relief valve regularly to compensate for water that has expanded upon heating. However if a large volume of water is being discharged with steam, then turn off power to the heat pump and call a service technician. If there is a small but continuous leak, operate the lever on the relief valve a couple of times to see if the leak stops, if the leak continues call a service technician.
	The water inside the tank is cold and the heat pump is not running	Check that power is available at the switchboard supplying the heat pump and that its circuit breaker is on or that the fuse is in. If there is an isolator switch for the heat pump installed check that this is not switched off. If the circuit breaker is tripped or the fuse is blown call a service technician.
	Power is available to the heat pump but it is not running and the water in the tank is cold	The heat pump may have shutdown due to a fault condition. Turn power off to the heat pump for a few seconds and then power it back on. This may reset the heat pump from a protection mode (due to a power surge etc.). If this occurs again, this may indicate a fault condition, call a service technician.
	There is low water pressure or flow coming from the hot taps or fixtures	Check that all isolation valves in the water system are fully opened (e.g. isolation valve at mains water meter, isolation valve at inlet to hot water system). Also check that all filters in the hot water system are clean and free from blockages including any filters on individual taps or fixtures and the tempering valve.

This document sets out the terms and conditions of the product warranties for Electrolux Appliances. It is an important document. Please keep it with your proof of purchase documents in a safe place for future reference should you require service for your Appliance.

1. In this warranty:
 - (a) 'acceptable quality' as referred to in clause 10 of this warranty has the same meaning referred to in the ACL;
 - (b) 'ACL' means Schedule 2 to the Competition and Consumer Act 2010;
 - (c) 'Appliance' means any Electrolux product purchased by you accompanied by this document;
 - (d) 'ASC' means Electrolux authorised service centres;
 - (e) 'Electrolux' means Electrolux Home Products Pty Ltd of 163 O'Riordan Street, Mascot NSW 2020, ABN 51 004 762 341 in respect of Appliances purchased in Australia and Electrolux (NZ) Limited (collectively 'Electrolux') of 3-5 Niall Burgess Road, Mount Wellington, in respect of Appliances purchased in New Zealand;
 - (f) 'major failure' as referred to in clause 10 of this warranty has the same meaning referred to in the ACL and includes a situation when an Appliance cannot be repaired or it is uneconomic for Electrolux, at its discretion, to repair an Appliance during the Warranty Period;
 - (g) 'Warranty Period' means the Appliance is warranted against manufacturing defects in Australia and in New Zealand for the period of 1 year, following the date of original purchase of the Appliance. Specific components are warranted against manufacturing defects in Australia for the periods listed below if there is evidence provided to Electrolux that the Appliance was installed by a licensed plumber; and in New Zealand if there is evidence that the Appliance was installed according to the Electrolux installation guidelines which can be inspected on the Kelvinator website;
 - Hot water tank - cylinder 5 years , labour 3 years, parts 1 year
 - Continuous Gas
 - Heat Exchanger – parts 10 years, labour 3 years
 - all others components - parts 3 years, labour 3 years
 - Heat Pump Refrigerant Sealed System - 2 years parts and labour
 - Solar Collectors - parts 5 years, labour 3 years, 1 year for all other parts (mounting and connection sets)
 - (h) 'you' means the purchaser of the Appliance not having purchased the Appliance for re-sale, and 'your' has a corresponding meaning.
2. This warranty only applies to Appliances purchased and used in Australia or New Zealand and used in normal domestic applications and is in addition to (and does not exclude, restrict, or modify in any way) any non-excludable statutory warranties in Australia or New Zealand.
3. During the Warranty Period Electrolux or its ASC will, at no extra charge if your Appliance is readily accessible for service, without special equipment and subject to these terms and conditions, repair or replace any parts which it considers to be defective. Electrolux or its ASC may use remanufactured parts to repair your Appliance. You agree that any replaced Appliances or parts become the property of Electrolux. This warranty does not apply to light globes, batteries, filters or similar perishable parts.
4. Parts and Appliances not supplied by Electrolux are not covered by this warranty.
5. To the extent permitted by law, you will bear the cost of transportation, travel and delivery of the Appliance to and from Electrolux or its ASC. If you reside outside of the service area, you will bear the cost of:
 - (a) travel of an authorised representative;
 - (b) transportation and delivery of the Appliance to and from Electrolux or its ASC.

In all instances, unless the Appliance is transported by Electrolux or an Electrolux authorised representative, the Appliance is transported at the owner's cost and risk while in transit to and from Electrolux or its ASC.

6. Proof of purchase is required before you can make a claim under this warranty.
7. You may not make a claim under this warranty unless the defect claimed is due to faulty or defective parts or workmanship. Electrolux is not liable in the following situations (which are not exhaustive):
 - (a) the Appliance is damaged by:
 - (i) accident
 - (ii) misuse or abuse, including failure to properly maintain or service
 - (iii) normal wear and tear
 - (iv) power surges, electrical storm damage, excessive water pressure, excessive inlet water temperature or incorrect power supply
 - (v) incomplete or improper installation
 - (vi) incorrect, improper or inappropriate operation
 - (vii) insect or vermin infestation
 - (viii) failure to comply with any additional instructions supplied with the Appliance;
 - (ix) quality of water that is not in accordance with the "Water Quality" guidelines in the installation instructions;
 - (b) the Appliance is modified without authority from Electrolux in writing;
 - (c) the Appliance's serial number or warranty seal has been removed or defaced;
 - (d) the Appliance was serviced or repaired by anyone other than Electrolux, an authorised repairer or ASC.
8. This warranty, the contract to which it relates and the relationship between you and Electrolux are governed by the law applicable where the Appliance was purchased. Where the Appliance was purchased in New Zealand for commercial purposes the Consumer Guarantee Act does not apply.
9. To the extent permitted by law and subject to your non-excludable statutory rights and warranties, Electrolux excludes all warranties and liabilities (other than as contained in this document) including liability for any loss or damage whether direct or indirect arising from your purchase, use or non use of the Appliance.
10. For Appliances and services provided by Electrolux in Australia, the Appliances come with a guarantee that cannot be excluded under the ACL. You are entitled to a replacement or refund for a major failure and for compensation for any other reasonably foreseeable loss or damage. You are also entitled to have the Appliance repaired or replaced if the Appliance fails to be of acceptable quality and the failure does not amount to a major failure. The benefits to you given by this warranty are in addition to your other rights and remedies under a law in relation to the Appliances or services to which the warranty relates.
11. At all times during the Warranty Period, Electrolux shall, at its discretion, determine whether repair, replacement or refund will apply if an Appliance has a valid warranty claim applicable to it.
12. For Appliances and services provided by Electrolux in New Zealand, the Appliances come with a guarantee by Electrolux pursuant to the provisions of the Consumer Guarantees Act, the Sale of Goods Act and the Fair Trading Act.
13. To enquire about claiming under this warranty, please follow these steps:
 - (a) carefully check the operating instructions, user manual and the terms of this warranty;
 - (b) have the model and serial number of the Appliance available;
 - (c) have the proof of purchase (e.g. an invoice) available;
 - (d) telephone the numbers shown below.
14. You accept that if you make a warranty claim, Electrolux and its ASC may exchange information in relation to you to enable Electrolux to meet its obligations under this warranty.

Important Notice

Before calling for service, please ensure that the steps listed in clause 13 above have been followed.

<p>FOR SERVICE or to find the address of your nearest state service centre in Australia PLEASE CALL 13 62 26 For the cost of a local call (Australia only)</p>	<p>SERVICE AUSTRALIA  Electrolux ELECTROLUX HOME PRODUCTS www.electrolux.com.au</p>	<p>FOR SPARE PARTS or to find the address of your nearest state spare parts centre in Australia PLEASE CALL 1300 666 019 For the cost of a local call (Australia only)</p>
<p>FOR SERVICE or to find the address of your nearest authorised service centre in New Zealand FREE CALL 0800 10 66 10 (New Zealand only)</p>	<p>SERVICE NEW ZEALAND  Electrolux ELECTROLUX (NZ) Limited www.electrolux.co.nz</p>	<p>FOR SPARE PARTS or to find the address of your nearest state spare parts centre in New Zealand FREE CALL 0800 10 66 20 (New Zealand only)</p>

If you'd like further information about Kelvinator appliances, please visit your retailer, phone or email our Customer Care team or visit our website.

telephone: 136 226

fax: 1800 350 067

email: hotwatersystems@electrolux.com.au

web: www.kelvinator.com.au

Kelvinator. We are part of the Electrolux family.
Share more of our thinking at www.electrolux.com.au