

# Aero

## Cordless Floor Washer

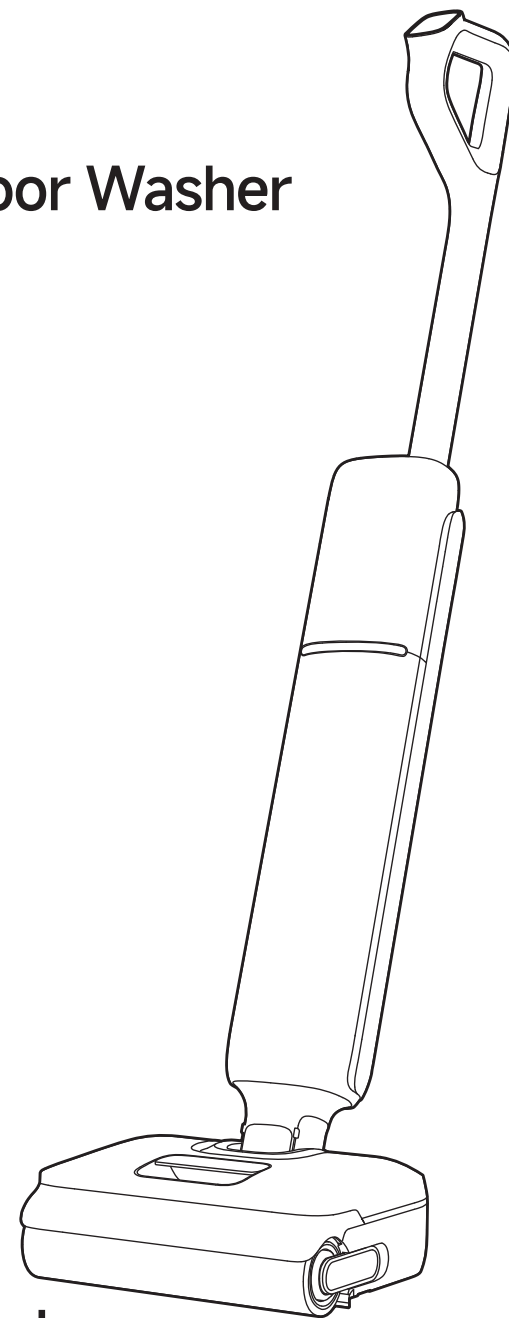

## User Manual

The illustrations in this manual are for reference only.  
Please refer to the actual product.

**DREAME**

Website: <https://global.dreametech.com>  
Manufactured by: Dreame Trading (Tianjin) Co.,Ltd.  
Made in China



# THANK YOU

## FOR PURCHASING THIS DREAME WET AND DRY VACUUM

---

### Scan for Quick Start

Scan the QR code to access the video tutorial and the user manual.

Register your Dreame account to receive special offers and updates.



### Contact Us for Support

Your satisfaction is our priority. Before considering a return, please reach out to our friendly support team. We are ready to help troubleshoot and find a solution, ensuring you get the most out of your product.



Customer Service: +1 (866) 977-5177  
(Mon.to Sat.9:00-21:00, Sun.9:00-12:00 Eastern Time)



support.na@dreame.tech

---

## Contents

<b>EN</b> User Manual	01
<b>FR</b> Mode d'emploi	16
<b>AES</b> Manual del usuario	30

## Important Safety Instructions

When using an electrical appliance, basic precautions should always be followed, including the following:

**READ ALL INSTRUCTIONS BEFORE USING (THIS APPLIANCE).** Failure to follow the warnings and instructions may result in electric shock, fire and/or serious injury.

**WARNING-** To reduce the risk of fire, electric shock, or injury:

- Do not use outdoors. Do not use on wet surfaces during charging.
- Do not allow to be used as a toy. Close attention is necessary when used by or near children, pets or plants.
- Use only as described in this manual. Use only manufacturer's recommended attachments.
- Do not use with damaged cord or plug. If appliance is not working as it should, has been dropped, damaged, left outdoors, or dropped into water, return it to a service center.
- Do not pull or carry by cord, use cord as a handle, close a door on cord, or pull cord around sharp edges or corners. Do not run appliance over cord. Keep cord away from heated surfaces.
- Do not unplug by pulling on cord. To unplug, grasp the plug, not the cord.
- Do not handle charging base, including charging base plug, and charging base terminals with wet hands.
- Do not put any object into openings. Do not use with any opening blocked; keep free of dust, lint, hair, and anything that may reduce air flow.
- Keep hair, loose clothing, fingers, and all parts of body away from openings and moving parts.
- Use extra care when cleaning on stairs.
- Do not use to pick up flammable or combustible liquids, such as gasoline, or use in areas where they may be present.
- Do not pick up anything that is burning or smoking, such as cigarettes, matches, or hot ashes.
- To reduce the risk of fire, do not use a flammable or combustible liquid to clean a floor.
- Do not use without water tank and/or filter in place.
- Prevent unintentional starting. Ensure the switch is in the off-position before picking up or carrying the appliance. Carrying the appliance with your finger on the switch or energizing appliance that has the switch on invites accidents.
- Recharge only with the charger specified by the manufacturer. A charger that is suitable for one type of battery pack may create a risk of fire when used with another battery pack.
- Use appliances only with specifically designated battery packs. Use of any other battery packs may create a risk of injury and fire.
- When battery pack is not in use, keep it away from other metal objects, like paper clips, coins, keys, nails, screws or other small metal objects, that can make a connection from one terminal to another. Shorting the battery terminals together may cause burns or a fire.

## Important Safety Instructions

- Under abusive conditions, liquid may be ejected from the battery; avoid contact. If contact accidentally occurs, flush with water. If liquid contacts eyes, additionally seek medical help. Liquid ejected from the battery may cause irritation or burns.
- Do not use a battery pack or appliance that is damaged or modified. Damaged or modified battery packs may exhibit unpredictable behavior resulting in fire, explosion or risk of injury.
- Do not expose a battery pack or appliance to fire or excessive temperature. Exposure to fire or temperature above 130° C/266° F may cause explosion.
- Follow all charging instructions and do not charge the battery pack or appliance outside of the temperature range specified in the instructions. Charging improperly or at temperatures outside of the specified range may damage the battery and increase the risk of fire.
- Have servicing performed by a qualified repair person using only identical replacement parts. This will ensure that the safety of the appliance is maintained.
- Do not modify or attempt to repair the appliance or the battery pack except as indicated in the instructions for use and care.
- Always turn off this appliance before connecting or disconnecting motorized nozzle.
- Risk of injury. Brush may start unexpectedly. Keep the switch in off position before cleaning or servicing.
- Turn off all controls before unplugging.
- The appliance should be stored, used and charged only in the temperature range of 4° C/39.2° F~40° C/104° F.
- This appliance contains batteries that are non-replaceable.
- To reduce the risk of fire and electric shock due to internal component damage, use only dreamer cleaning fluid intended for use with this appliance. See the Cleaning Fluid section of this manual.

### SAVE THESE INSTRUCTIONS

Household use only.

To reduce the risk of electric shock, the appliance has a polarized plug (one-blade is wider than the other). This-plug will fit in a polarized outlet-only one-way. If the plug does not fit fully in the outlet, reverse the plug. If it still does not fit, contact a qualified electrician-to install the proper outlet. Do not change the plug in any way.

---	Direct current
~	Alternating current

# FCC Information

Compliance Information	
Product Name	Cordless Floor Washer with Power Adapter
Produce Model	Cordless Floor Washer Model: HHR32A Power Adapter Model: YLS0251B-T260090 / XHD024-260090USV
Compliance Statement	This device complies with part 15 of the FCC Rules. Operation is subject to the following two conditions: (1) This device may not cause harmful interference, and (2) this device must accept any interference received, including interference that may cause undesired operation.
Correspondence of the responsible party in USA	
Company	DREAME TECHNOLOGY USA INC
Address	16192 Coastal Highway, Lewes, Delaware 19958, County of Sussex
Email	support.us@dreame.tech

## Caution:

This device complies with Part 15 of the FCC Rules / Innovation, Science and Economic Development Canada's licence-exempt RSS(s). Operation is subject to the following two conditions: (1) this device may not cause harmful interference. (2) this device must accept any interference received, including interference that may cause undesired operation.

Changes or modifications not expressly approved by the party responsible for compliance could void the user's authority to operate the equipment.

This equipment has been tested and found to comply with the limits for a Class B digital device, pursuant to part 15 of the FCC Rules. These limits are designed to provide reasonable protection against harmful interference in a residential installation. This equipment generates uses and can radiate radio frequency energy and, if not installed and used in accordance with the instructions, may cause harmful interference to radio communications. However, there is no guarantee that interference will not occur in a particular installation. If this equipment does cause harmful interference to radio or television reception, which can be determined by turning the equipment off and on, the user is encouraged to try to correct the interference by one or more of the following measures:

- Reorient or relocate the receiving antenna.
- Increase the separation between the equipment and receiver.
- Connect the equipment into an outlet on a circuit different from that to which the receiver is connected.
- Consult the dealer or an experienced radio/TV technician for help.

# Product Overview

## Packing List



Handle

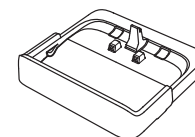

Charging Base

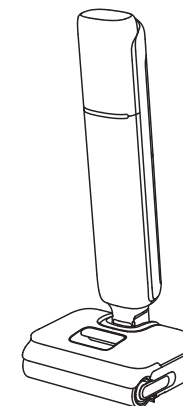

Main Body



Power Adapter



Cleaning Brush



Filter

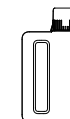

Cleaner

# Product Overview

## Vacuum

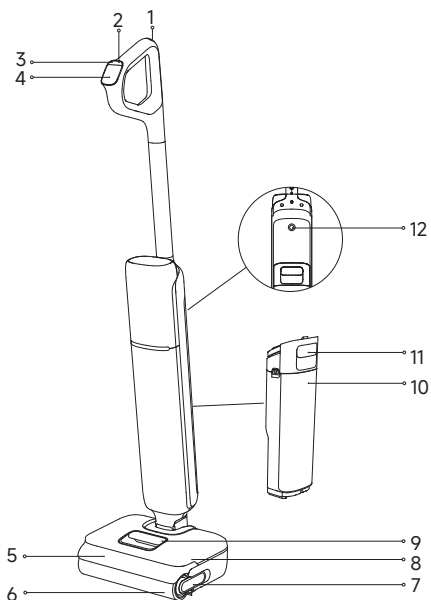

- |   |                      |    |                         |    |                        |
|---|----------------------|----|-------------------------|----|------------------------|
| 1 | Self-Cleaning Button | 6  | Roller Brush            | 11 | Used Water Tank Handle |
| 2 | Power Switch         | 7  | Roller Brush Handle     | 12 | Omnidirectional Wheel  |
| 3 | Mode Switch          | 8  | Clean Water Tank        |    |                        |
| 4 | Display Screen       | 9  | Clean Water Tank Handle |    |                        |
| 5 | Roller Brush Cover   | 10 | Used Water Tank         |    |                        |

## Charging Base

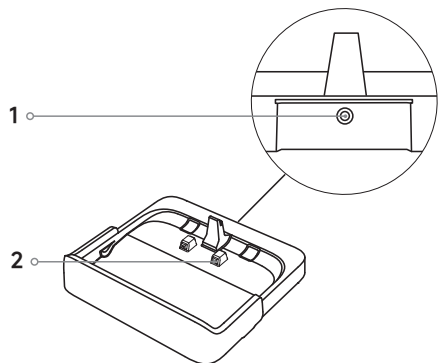

1. Charging Port
2. Charging Contacts

# Installation & Charging

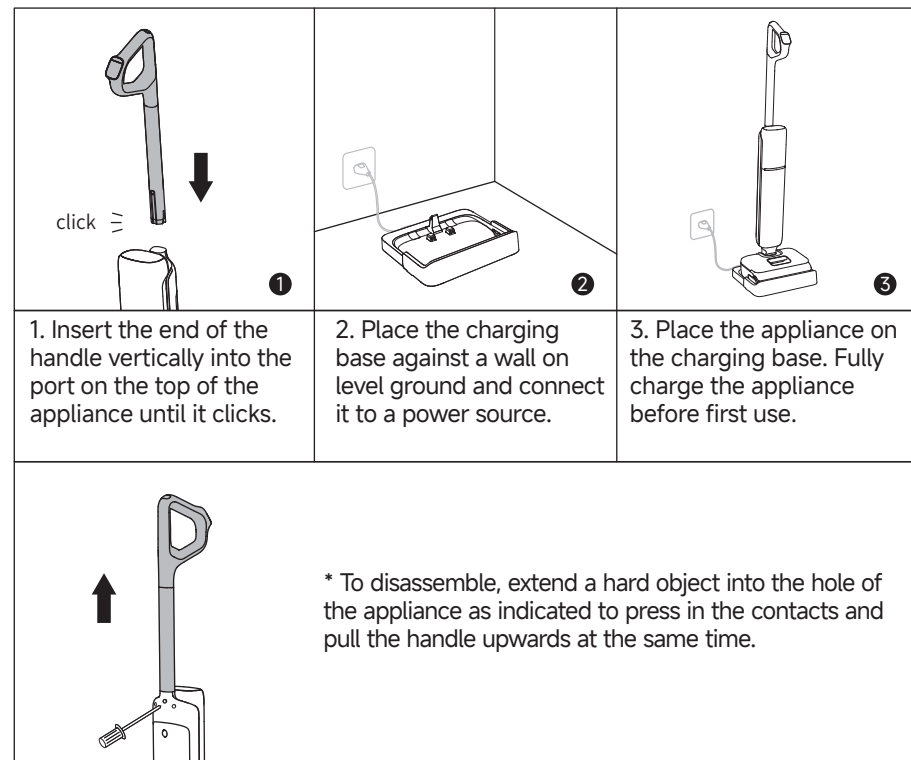

Fully charge the appliance before first use.



### Note:

- If there is no operation within 10 minutes of being fully charged, the appliance will enter sleep mode. Please restart the appliance if you need to use it.
- To extend the battery life time, the battery keeps cooling down automatically after you have used the appliance for a long time.

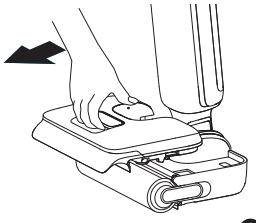
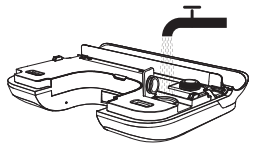
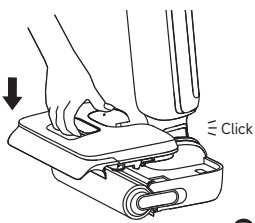
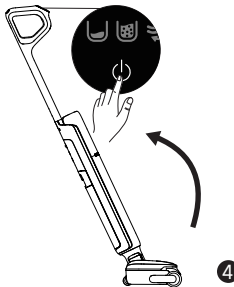
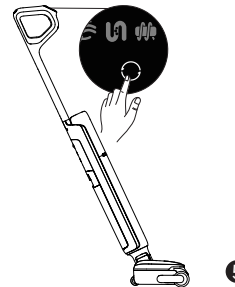
## Starting Cleaning

 <p>1</p>	 <p>2</p>	 <p>Click</p> <p>3</p>
<p>1. Remove the tank.</p>	<p>2. Open the tank cover and fill the tank with clean water.</p>	<p>3. Reinstall the clean water tank until it clicks.</p>
 <p>4</p>	 <p>5</p>	
<p>4. Gently step on the floor brush and recline the appliance backwards. Briefly press the power switch  to start/stop operating.</p>	<p>5. Briefly press the mode switch  to switch modes according to your needs.</p>	

### Note:

- Do not vacuum any foamy liquids.
- The appliance is suitable for cleaning floors, marble, tiles and other hard surfaces.
- When the appliance is in operation, do not lift it off the ground, move it or tilt it. Otherwise, the used water may flow into the motor.
- When powered on for the first time, the device defaults to Smart Mode. For subsequent use, it will automatically enter the last used mode upon startup.

## Add Cleaning Fluid











To reduce the risk of fire and electric shock due to internal component damage, use only Dreame Trading (Tianjin) Co., Ltd. AWH10 cleaning fluid intended for use with the appliance.

1. Remove the seal before use.
2. Measure the floor cleaner with the bottle cap (\*approximately 10 ml/0.34 fl oz per cap).
3. Pour it into the clean water tank and gently shake to mix it evenly before use.

Note: Do not add any liquids other than the officially-approved cleaner. The cleaner can be available on the official online store. Refer to the cleaning solution label for specific usage instructions.

## Display Screen





-  **Standard Mode**  
Medium suction power and water flow for routine cleaning.
-  **Quiet Mode**  
The appliance will maintain moderate suction power at a low noise level.
-  **Turbo Mode**  
Maximum suction power and increased water flow for stubborn stains on hard floors.
-  **Suction Mode**  
Suck up a large amount of water from the floor.
-  **Self-Cleaning Mode**
-  **Insufficient water in the clean water tank**
-  **The used water tank is full**
-  **Blocked tube**
-  **Roller brush stuck**
-  **Appliance malfunction**
-  **Battery Indicator**
  - Green: 50% < Battery level ≤ 100%
  - Red: Battery level ≤ 20%

\*Battery Indicator color cycles from green to yellow, orange, and red as charge decreases. Recharge when red.

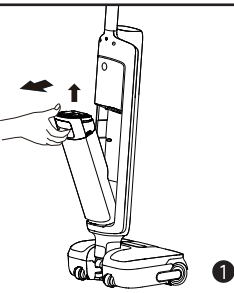
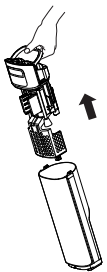
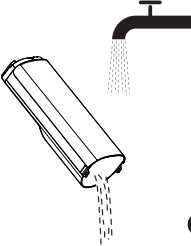
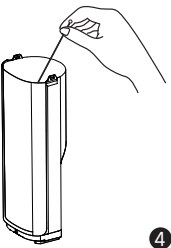
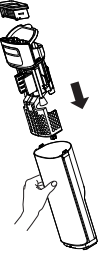
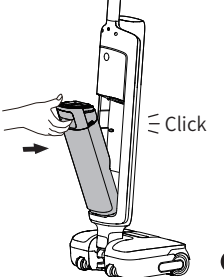
## Emptying the Used Water Tank

		
<p>1. Press the used water tank release button to take out the tank.</p>	<p>2. Hold the used water tank cover and pull it out. Hold the filter and pull up to remove. Remove debris from filter.</p>	<p>3. Pour dirty water out and rinse tank with clean water.</p>
		
<p>4. Use the provided cleaning brush to clean the inner walls of the tank.</p>	<p>5. After cleaning, insert filter into the used water tank cover, and insert used water tank cover into the tank.</p>	<p>6. Reinstall the Used Water Tank until you hear a click.</p>

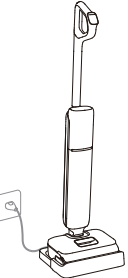
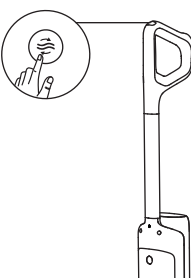
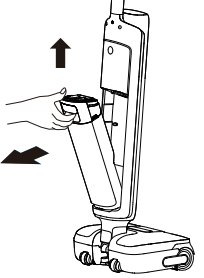

## One-Press Self-Cleaning



		
<p>1. Place the appliance back onto the base. Ensure that the water in the clean water tank is sufficient for self-cleaning.</p>	<p>2. Briefly press the self-cleaning button on the top of the handle to start/stop self-cleaning (Battery level <math>\geq 20\%</math>).</p>	<p>3. After self-cleaning is complete, the  will light up. Empty the used water tank promptly.</p>

## Care & Maintenance

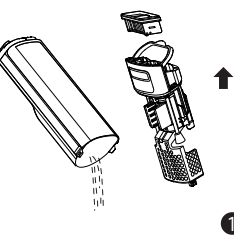
### Tips:

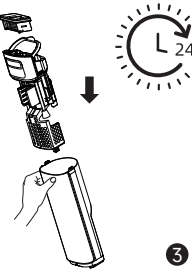
- Turn off the appliance before maintenance. Do not touch the power switch.
- Replace parts if needed. The parts must be replaced by those available from the manufacturer or its service agent.
- If the appliance is not used for an extended period, fully charge it, unplug the power plug, and store the appliance in a cool, low-humidity environment away from direct sunlight. To avoid over-discharge of the battery, charge the appliance at least once every 3 months.

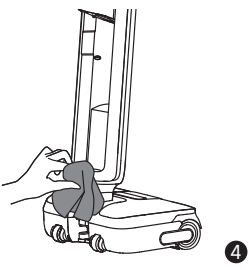
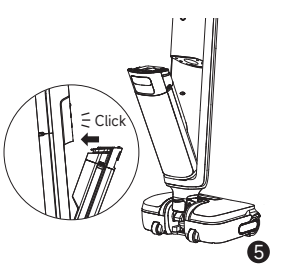
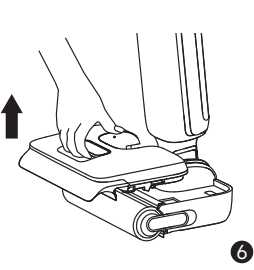
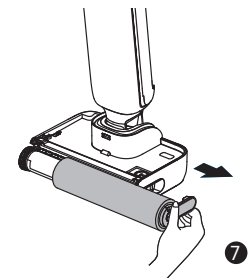
		
<p>1. Pour dirty water out, remove the filter, and rinse tank and tank cover with clean water.</p>	<p>2. Gently knock off the floating dust on the filter surface. When the filter is dirty and needs washing, rinse it with water.</p>	<p>3. After fully drying the filter, reinstall it into the used water tank cover. Insert used water tank cover into the tank.</p>

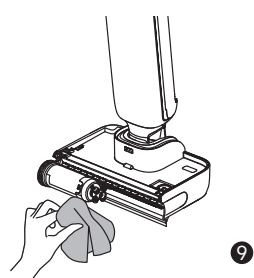
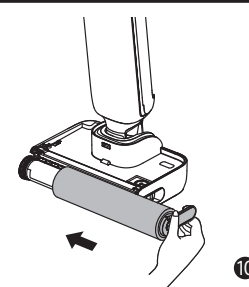
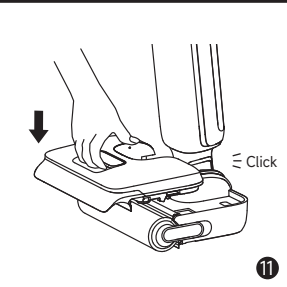
		
4. Gently wipe the tube with a wet cloth before use. Do not rinse the tube.	5. Insert bottom of tank into main body. Tilt tank towards main body until it clicks.	6. Remove the clean water tank.
		
7. Pull out the brush handle and remove the brush.	8. Remove hair or debris tangled on the roller brush with the provided cleaning brush. Rinse the roller brush with clean water.	9. Wipe the suction inlet with a dry cloth or wet tissue. Do not rinse the brush assembly with water.
		
10. After fully drying the roller brush, hold the roller brush handle and reinstall it.	11. Reinstall the clean water tank until you hear a click.	* Remove the roller brush handle to replace it with a new roller brush, and press it firmly into place.

Note:

- Replacing the filter every 3 to 6 months is recommended.
- Clean as needed. Replacing the roller brush every 3 to 6 months is recommended.

## Troubleshooting

If an error occurs, the appliance will stop working. Please refer to the following table for troubleshooting. If the problem persists, please contact customer service.

Error	Possible Cause	Solution
The appliance does not work.	The appliance is out of battery or its battery level is low.	Fully charge its battery before use.
	The appliance is in the upright position.	Recline the appliance backwards.
	Blockage activated overheat protection mode.	Clear the blockage and wait until the temperature returns normal.
	The Used Water Tank is full.	Empty the Used Water Tank.
The appliance charges slowly.	The temperature of the battery is too low or too high.	Wait until the battery's temperature returns normal.
	The filter is clogged.	Cleaning the filter.
The suction power of the appliance is weak.	The suction inlet or tube is blocked by a foreign object.	Clean the tube and the suction inlet.
	The motor is making a strange noise.	There is too much used water in the Used Water Tank.
The display screen does not light up while charging.	The suction inlet is blocked.	Clear any blockage in the suction inlet.
	The charging base cable is not plugged into the electrical outlet.	Make sure the charging base cable is plugged in.
No water is coming out of the appliance.	The appliance is not placed onto the charging base properly.	Make sure the appliance is placed onto the charging base properly.
	The Clean Water Tank is not properly installed in place, or the water in the Clean Water Tank is insufficient.	Reinstall or fill the Clean Water Tank.
	It takes 30 seconds to dampen the roller brush.	Turn on the appliance and check again in 30 seconds.





## Troubleshooting

The vent leaks water.	A collision or a sharp pull causes water to enter the motor.	Move the appliance gently back and forth while it is turned on.
	The filter is not completely dry after being cleaned.	Dry the filter completely before use.
Self-cleaning fails.	The roller brush may be jammed by large debris.	Open the roller brush cover to check and clean the roller brush.
	The appliance is not placed onto the charging base properly.	Make sure the appliance is being charged before self-cleaning.
	Self-cleaning cannot be enabled if the battery level is lower than 20%.	The self-cleaning function can only be enabled when the appliance is being charged and the battery level is more than 20%.
	The Used Water Tank is not installed in place, or the Used Water Tank is full.	Reinstall or empty the Used Water Tank.
	The Clean Water Tank is not installed in place, or the water in the Clean Water Tank is insufficient.	Reinstall or fill the Clean Water Tank.

For additional services, please contact us via <https://global.dreametech.com/pages/contact-us>  
Website: <https://global.dreametech.com>

## Error Prompts and Solutions

If the appliance is not working properly, the screen display will show an error message. Please refer to the troubleshooting table to find your solution.

Error Icon	Possible Cause	Solution
	Insufficient water.	Fill the clean water tank.
	The Used Water Tank is full.	Please clean the used water tank.
	Roller brush stuck.	Clean the roller brush.
	Blocked tube.	Refer to the Care & Maintenance section to clean the tube and dirt sensor.
	Appliance malfunction	Restart the appliance for troubleshooting. If the problem persists, please contact customer service.

## Specifications

Cordless Floor Washer			
Model	HHR32A	Charging Time	≤ 4 hours
Rated Voltage	21.6 V ---	Rated Power	315 W
Clean Water Tank Capacity	1000 mL	Used Water Tank Capacity	500 mL
Power Adapter 1			
Model	YLS0251B-T260090		
Rated Input	100-240 V ~ 50/60 Hz 0.8 A Max	Rated Output	26.0 V --- 0.9 A
Power Adapter 2			
Model	XHD024-260090USV		
Rated Input	100-240 V ~ 50/60 Hz 0.8 A	Rated Output	26.0 V --- 0.9 A

# Battery Disposal and Removal

The built-in lithium-ion battery contains substances that are hazardous to the environment. Before disposing of the battery, make sure the battery is removed by qualified technicians and discarded at an appropriate recycling facility.

- the battery must be removed from the appliance before it is scrapped;
- the appliance must be disconnected from the supply mains when removing the battery;
- the battery is to be disposed of safely.

## Removal Guide

1. Use tools to sequentially disassemble the main unit of the appliance and the power source components.
2. Disconnect the terminal connecting the battery to the mainboard.
3. Use tools to sequentially remove the screws securing the battery bracket, then pry open the bracket with a tool and remove the battery.
4. Disassembly should be performed by the manufacturer, an authorized service provider, or qualified professionals.

## CAUTION:

- Before removing the battery, disconnect the power and run out the battery as much as possible.
- Unneeded batteries should be discarded at an appropriate recycling facility.
- Do not expose to high temperature environment to avoid risks of explosion.
- Under abusive conditions, liquid may be ejected from the battery. If contact occurs, flush with water and seek medical help.

## Warranty

1. Dreame is liable to the consumer for any lack of conformity in material or workmanship not detectable at the time of the purchase.
2. Warranty period: please refer to the customer service office for more information. If the territory where the consumer is located has different regulations, local regulations prevail.
3. The warranty will not be applicable in the following cases:
  - a) Issues due to carelessness, use, or installation that does not comply with the instructions provided by Dreame.
  - b) Tampering and/or modifications of the product by entities or individuals not expressly authorized by Dreame.
  - c) Damage due to accidental causes and/or negligence on the part of the consumer, with particular reference to external parts.
  - d) Parts subject to wear that do not have manufacturing defects.
  - e) No valid purchasing document (receipt, invoice, or other) is provided to certify the date the product was purchased.
  - f) The model and/or numbers of the product on the purchase certificate is not consistent with the model and/or numbers shown on the product.
4. For more warranty information, please refer to the official Dreame website: <https://global.dreametech.com>



### WEEE Information

All products bearing this symbol are waste electrical and electronic equipment (WEEE as in directive 2012/19/EU) which should not be mixed with unsorted household waste. Instead, you should protect human health and the environment by handing over your waste equipment to a designated collection point for the recycling of waste electrical and electronic equipment, appointed by the government or local authorities. Correct disposal and recycling will help prevent potential negative consequences to the environment and human health. Please contact the installer or local authorities for more information about the location as well as terms and conditions of such collection points.

# Instructions importantes de sécurité

## INSTRUCTIONS IMPORTANTES DE SÉCURITÉ

Lors de l'utilisation d'un appareil électrique, des précautions de base doivent toujours être prises, notamment les suivantes :

**LISEZ TOUTES LES INSTRUCTIONS AVEC D'UTILISER (CET APPAREIL).** Ces messages d'avertissement et ces instructions doivent être suivis pour éviter les risques d'électrocution, de départ de feu et d'éventuelles blessures.

**AVERTISSEMENT-** Pour éviter les risques de départ de feu, de choc électrique ou de blessures :

- N'utilisez pas l'appareil à l'extérieur. N'utilisez pas l'appareil sur des surfaces mouillées pendant la charge.
- Ne le laissez pas être utilisé comme jouet. Une attention particulière est nécessaire en cas d'utilisation par ou à proximité d'enfants, d'animaux de compagnie ou de plantes.
- Utilisez uniquement comme indiqué dans ce manuel. N'utilisez que les accessoires recommandés par le fabricant.
- N'utilisez pas l'appareil avec un cordon ou une fiche endommagé(e). Si l'appareil ne fonctionne pas comme il le devrait, s'il est tombé, s'il a été endommagé, s'il est resté à l'extérieur ou s'il est tombé dans l'eau, retournez-le à un centre de service.
- Évitez de tirer ou de transporter par le cordon, d'utiliser le cordon comme une poignée, de fermer une porte sur le cordon et de tirer le cordon autour de bords ou d'angles tranchants. Ne faites pas passer l'appareil sur le cordon. Éloignez le cordon des surfaces chauffées.
- Ne débranchez pas l'appareil en tirant sur le cordon. Pour débrancher l'appareil, saisissez la fiche et non le cordon.
- Ne manipulez pas le socle de recharge, y compris la fiche du socle de recharge, et les bornes du socle de recharge avec des mains mouillées.
- Ne mettez aucun objet dans les ouvertures. N'utilisez pas l'appareil si l'une de ses ouvertures est obstruée ; gardez-le à l'abri de la poussière, des peluches, des cheveux et de tout ce qui pourrait réduire le flux d'air.
- Éloignez les cheveux, les vêtements amples, les doigts et les autres parties du corps des ouvertures et des pièces mobiles.
- Faites très attention lorsque vous nettoyez les escaliers.
- N'utilisez pas l'appareil pour aspirer des liquides inflammables ou combustibles, tels que l'essence, ni dans des zones où ils peuvent être présents.
- N'aspirez rien qui brûle ou qui fume, comme des cigarettes, des allumettes ou des cendres chaudes.
- Pour réduire le risque de départ de feu, n'utilisez pas de liquide inflammable ou combustible pour nettoyer un sol.
- N'utilisez pas l'appareil sans le réservoir d'eau et/ou le filtre en place.
- Empêchez tout démarrage intempestif. Assurez-vous que l'interrupteur est en position d'arrêt avant de prendre ou de transporter l'appareil. Le fait de porter l'appareil avec le doigt sur l'interrupteur ou d'allumer l'appareil activé peut provoquer un accident.
- Rechargez uniquement avec le chargeur spécifié par le fabricant. Un chargeur adapté à un type de batterie peut créer un risque de départ de feu s'il est utilisé avec une autre batterie.
- N'utilisez les appareils qu'avec des batteries spécialement conçues à cet effet. L'utilisation d'autres batteries peut entraîner des risques de blessures et de départ de feu.

## Instructions importantes de sécurité

- Lorsque la batterie n'est pas utilisée, tenez-la à l'écart d'autres objets métalliques, comme des trombones, des pièces de monnaie, des clés, des clous, des vis ou d'autres petits objets métalliques, qui peuvent connecter les bornes entre elles. La mise en court-circuit des bornes de la batterie peut provoquer des brûlures ou un départ de feu.
- En cas d'usage abusif, du liquide peut s'échapper de la batterie ; évitez tout contact. En cas de contact accidentel, rincez à l'eau. En cas de contact du liquide avec les yeux, consultez également un médecin. Le liquide éjecté de la batterie peut provoquer des irritations ou des brûlures.
- N'utilisez pas une batterie ou un appareil endommagé ou modifié.
- Une batterie endommagée ou modifiée peut avoir un comportement imprévisible et provoquer un incendie, une explosion ou un risque de blessure.
- N'exposez pas une batterie ou un appareil au feu ou à une température excessive. L'exposition au feu ou à une température supérieure à 130 °C peut provoquer une explosion.
- Suivez toutes les instructions de chargement et ne chargez pas la batterie ou l'appareil en dehors de la plage de température spécifiée dans les instructions. Une mise en charge incorrecte ou à des températures en dehors de la plage spécifiée peut endommager la batterie et augmenter le risque de départ de feu.
- Confiez l'entretien de l'appareil à un réparateur qualifié qui n'utilisera que des pièces de rechange identiques. Cela permet de garantir la sécurité de l'appareil.
- Ne modifiez pas ou n'essayez pas de réparer l'appareil ou la batterie sauf si cela est indiqué dans les instructions d'utilisation et d'entretien.
- Éteignez toujours cet appareil avant de brancher ou de débrancher la buse motorisée.
- Risque de blessures. La brosse peut démarrer de façon inattendue. Gardez le commutateur sur la position d'arrêt avant de nettoyer ou de réparer.
- Éteignez toutes les commandes avant de débrancher l'appareil.
- L'appareil doit être rangé, utilisé et chargé uniquement à une température comprise entre 4 °C~40 °C.
- Cet appareil contient des batteries qui ne sont pas remplaçables.
- Pour éviter les risques de départ de feu et de choc électrique dus à la détérioration des composants internes, n'utilisez que le liquide de nettoyage Dreame prévu pour l'appareil. Reportez-vous à la section Liquide de nettoyage du présent manuel.

## CONSERVEZ CES INSTRUCTIONS

Usage domestique uniquement.

Pour réduire le risque de choc électrique, l'appareil est équipé d'une fiche polarisée (une lame est plus large que l'autre). Cette fiche ne s'adapte à une prise polarisée que dans un sens. Si la fiche ne s'adapte pas complètement à la prise, inversez-la. Si elle ne s'adapte toujours pas, contactez un électricien qualifié pour installer une prise appropriée. Ne modifiez pas la fiche de quelque façon que ce soit.

---	Courant continu
~	Courant alternatif

## Instructions importantes de sécurité

### Attention :

Cet appareil est conforme à la partie 15 des Règles de la FCC/appareils radio exempts de licence Innovation, Sciences et Economic Development Canada. Le fonctionnement est soumis aux deux conditions suivantes : (1) Cet appareil ne doit pas provoquer d'interférences nuisibles. (2) Cet appareil doit accepter toute interférence reçue, y compris les interférences susceptibles de provoquer un fonctionnement indésirable.

Toutes modification ou altération de cet appareil qui n'est pas expressément approuvée par la partie responsable de la conformité peut entraîner une interdiction de l'autorisation de l'utilisateur à faire fonctionner l'équipement. Cet équipement a été testé et déclaré conforme aux limites d'un appareil numérique de classe B, conformément à la partie 15 des règles de la FCC. Ces limites sont conçues pour fournir une protection raisonnable contre les interférences nuisibles dans une installation résidentielle. Cet équipement génère, utilise et peut émettre de l'énergie par radio fréquence et s'il n'est pas installé conformément à ces instructions, des interférences nuisibles aux communications radio peuvent survenir. Cependant, il n'y a aucune garantie que des interférences ne se produiront pas dans certaines installations. Si cet équipement provoque des interférences nuisibles à la réception radio ou télévision, ce qui peut être vérifié en mettant l'appareil hors et sous tension, l'utilisateur doit essayer d'éliminer les interférences par l'une des méthodes suivantes:

- Réorienter ou déplacer l'antenne de réception.
- Augmenter la distance entre l'équipement et le récepteur.
- Brancher l'équipement sur une prise de courant située sur un circuit différent de celui sur lequel le récepteur est branché.
- Consulter le revendeur ou un technicien radio/TV expérimenté pour obtenir de l'aide.