

SENCOR®

SSJ 9000NP



EN ■ Slow Juicer

READ CAREFULLY AND STORE FOR FUTURE USE.

- This appliance may be used by persons with physical or mental impairments or by inexperienced persons, if they are properly supervised or have been informed about how to use the product in a safe manner and understand the potential dangers.
- Children must not use this appliance or play with it. Keep the appliance and its power cord out of their reach.
- This appliance is intended for home use. It is not intended for use in locations such as:
 - staff kitchens in stores, offices and other workplaces;
 - agricultural farms;
 - hotel or motel rooms and other living areas;
 - bed and breakfast establishments.
- Only place the appliance on a stable, even, dry surface. Do not place it on window sills, sink drainboards, unstable surfaces, on equipment that is a source of heat, or in its vicinity.
- Do not use the appliance in an industrial environment or outdoors.
- Only use the original accessories supplied with this appliance.
- Before connecting this appliance to a power socket, make sure the rated voltage stated on its rating label corresponds to the voltage in your power socket.
- Make sure that the appliance is correctly assembled before putting it into operation.
- Prior to juicing, remove from the fruit and vegetables any hard stones that are contained in them, for example, peaches, apricots, mangoes, etc., and inedible peels, e.g. from oranges, pineapples, melons, mandarins, etc. Seeds from berries and kiwi fruit do not need to be removed.
- Do not place ingredients that are too hard into the juicer, e.g. sugar cane, pepper, coffee beans, etc., or hard stones. Otherwise, the juicer may be damaged or an injury may result.
- The juicer may be used for pressing fresh garlic or capsicum, however, it is not intended for grinding dried spices.
- Thanks to the vertical position of the pressing auger, it is practically unnecessary to push the ingredients through the feed tube. The majority of ingredients will be automatically pulled into the juicing mechanism by the pressing auger. When ingredients need to be pushed through the feed tube, always use the supplied pusher. Do not use fingers or other items, e.g. kitchen utensils, etc. to push ingredients into the feed tube.



Warning:

Incorrect use may lead to injuries.

- In the event that ingredients become jammed inside the juicing mechanism, set the control knob to the "REVERSE" (reverse motor direction) position and hold it in this position for 15 to 20 seconds to release the jammed ingredients. Then set the desired speed to process the released ingredients.
- Regularly check the juice level in the juicing chamber and make sure that it does not overflow.
- The maximum continuous operating time of the appliance is 60 minutes. Then allow it to cool down for 30 minutes.
- Always turn off the appliance and disconnect it from the power socket when not being used and when leaving it without supervision, before assembling, disassembling, replacing accessories, moving or cleaning it.
- Before disassembling it, make sure that the appliance is turned off, disconnected from the power socket and that the rotating parts are not moving.
- When cleaning it, adhere to the instructions in chapter Cleaning and maintenance. Do not wash the motor unit under running water or submerge it in water or another liquid.
- Ensure that the power plug contacts do not come into contact with water or moisture.
- Do not place heavy items on the power cord. Make sure that the power cord does not hang over the edge of a table or that it is not touching a hot surface.
- Disconnect the appliance from the power socket by pulling on the plug, never pulling on the power cord. Otherwise, this could damage the power cord or the socket.
- If the power cord is damaged, it must be replaced by an authorised service centre or by another similarly qualified person, this will prevent the creation of a dangerous situation. It is forbidden to use the appliance if it has a damaged power cord.
- Do not use the appliance if any part of it is damaged. Do not repair the appliance yourself or make any adjustments to it. Have all repairs performed at an authorised service centre. By tampering with the appliance, you risk voiding your legal rights arising from unsatisfactory performance or quality warranty.

A

1



2

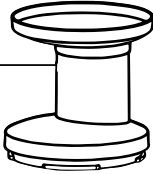

3



4



5

6

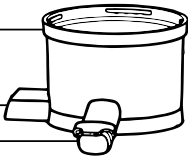

7

8

9

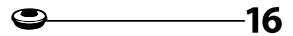
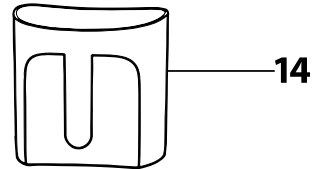
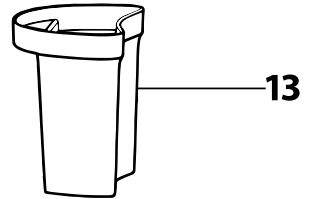
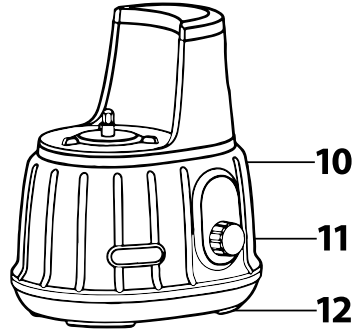
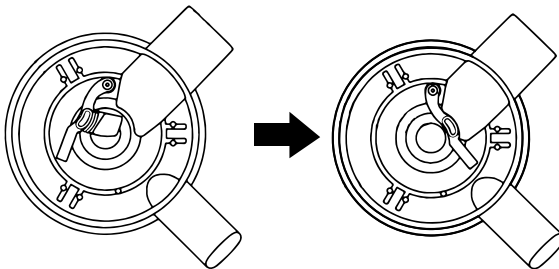
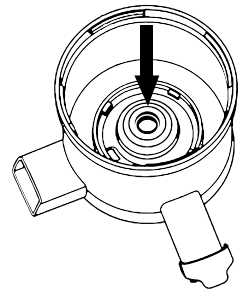
**B****C**

- Prior to using this appliance, please read the user's manual thoroughly, even in cases, when one has already familiarised themselves with previous use of similar types of appliances. Only use the appliance in the manner described in this user's manual. Keep this user's manual in a safe place where it can be easily retrieved for future reference.
- We recommend saving the original cardboard box, packaging material, purchase receipt and responsibility statement of the vendor or warranty card for at least the duration of the legal liability for unsatisfactory performance or quality. In the event of transportation, we recommend that you pack the appliance in the original box from the manufacturer.

DESCRIPTION OF THE JUICER

A1 Pusher	A11 Control knob serves to set the speed levels 1 to 3 (40 to 80 rpm), reverse the motor and turn off the motor unit.
A5 Lid with feed tube and hopper	A12 Anti-slip feet
A3 Pressing auger	A13 Pulp container with capacity of 1.2l
A4 Fine strainer	A14 Juice container with capacity of 1.2l
A5 Coarse strainer	A15 Cleaning brush
A6 Homogenisation insert	A16 Spare seal ring
A7 Juicing chamber	
A8 Pulp ejection chute	
A9 Closable juice spout	
A10 Motor unit	

THE PRINCIPLE AND ADVANTAGES OF A SLOW JUICER

- The slow juicer can juice various fruits and vegetables, including berries, leafy vegetables and green wheat, and prepare combinations of refreshing fresh juices, or delicious smoothies with the addition of milk and yoghurt. Two types of strainers, fine and coarse, will enable you to make juices with a finer texture and a smaller pulp content, or juices with a thicker consistency, greater pulp content and fuller flavour. Apart from fruits and vegetables you can place various nuts into the juicer to create homemade nut milks rich in vitamins and minerals. With the homogenisation insert, it is possible to quickly and easily prepare fresh fruit sorbets or ice creams.
- Thanks to the vertical position of the pressing auger, it is practically unnecessary to push the ingredients through the feed tube. The majority of ingredients will be automatically pulled into the juicing mechanism by the pressing auger. In the first phase, the pressing auger coarsely masticates the inserted ingredients. In the second phase, juice is pressed out and pulp is separated. The juice extracted in this way contains less fibre and retains valuable vitamins and enzymes.
- The juicer's closable spout makes it possible to allow the ingredients to mix directly in the juicing chamber to perfectly combine your favourite flavours.

CHOOSING THE RIGHT TYPE OF STRAINER

Fine strainer A4	It is used for extracting juice with a smaller pulp fibre content and for making nut or soya milks.
Coarse strainer A5	It is used for extracting juice with a higher pulp fibre content, for juicing soft types of fruit and vegetables (currants, raspberries, bilberries, tomatoes, etc.) and for making smoothie drinks.
Homogenisation insert A6	It is used for making fruit ice creams and sorbets. It does not separate juice from pulp.

BEFORE FIRST USE

- Remove all packaging materials, including promotional tags and labels from the juicer and its accessories.
- Thoroughly wash all removable parts that are intended to come into contact with food using warm water and a neutral kitchen detergent. Then rinse them under clean running water and thoroughly wipe dry with a wiping cloth. All removable parts are suitable for washing in a dishwasher (in the upper rack).



Attention:

Never submerge the motor unit **A10** or its power cord in water or rinse it under running water.

ASSEMBLING THE JUICER

- Make sure that the juicer is turned off and disconnected from the power socket.
- Place the motor unit **A10** on an even, dry and stable surface, for example on a kitchen countertop.

- Turn the juicing chamber **A7** upside down and properly push the seal ring on the underside of the juicing chamber **A7** into the opening in the pulp ejection chute **A8**, see figure B.
- Turn the juicing chamber **A7** back over and check that the seal ring (see figure C) is installed in its central part, or install it.
- Select the type of strainer you wish to use and insert it into the juicing chamber **A7**.
- Insert the pressing auger **A3** into the strainer and push it down properly. The top edge of the pressing auger **A3** should not be higher than the top edge of the strainer.
- Seat the lid **A2** on to the juicing chamber **A7** so that the symbol ▼ marked on it is aligned with the open padlock symbol marked on the juicing chamber **A7**. Turning the lid **A2** clockwise all the way will align the ▼ symbol marked on it with the closed padlock symbol marked on the juicing chamber **A7**. The locking of the lid **A2** in correct position is signalled by an audible click.
- Place the assembled juicing chamber **A7** on to the motor unit **A10** from above so that the symbol ▼ marked on it is aligned with the ▲ symbol marked on the motor unit **A10**. Make sure that the juicing chamber **A7** is properly seated on the motor unit **A10**.
- Insert the pusher **A1** into the feed tube. Place the pulp container **A13** under the pulp ejection chute **A8**, and place the juice container **A14** under the juice spout **A9**. The juicer is now assembled and ready for use.
- The juicer is equipped with a safe start system. This means that it will not start unless it is correctly assembled and the lid **A2** is properly secured in the correct position.

OVERVIEW OF INGREDIENTS AND THEIR PREPARATION

Fruit and vegetables Preparation

Peaches, apricots, nectarines, cherries, plums, etc.	Contain hard stones that need to be removed before juicing. From certain types of fruit, it is necessary to also remove inedible peels, e.g. from mango. Wash them under lukewarm running water and cut into pieces that will pass through the feed tube.
Apples, pears, etc.	Wash them under lukewarm running water and cut into pieces that will pass through the feed tube. May be juiced together with their peels and kernels. However, apple and pear kernels contain toxic amygdalin, so we recommend that they are removed, especially when you wish to consume a large amount of juice from these fruits.
Oranges, mandarins, grapefruits, lemons, etc.	Wash them. Peel them and cut them up into pieces that will pass through the feed tube.
Grapes, gooseberries, raspberries, blackberries, bilberries, kiwi fruit, cucumbers, pomegranate, tomatoes, etc.	Wash the fruits and vegetables using lukewarm water. Stems need to be removed from grapes. Cut up larger size fruits and vegetables. The peel from pomegranates needs to be removed. Only pomegranate kernels are used for juicing.
Pineapples, water melons, muskmelons	Wash the fruits under running lukewarm water and peel them. Remove muskmelon seeds. Cut them up into pieces that will pass through the feed tube.
Carrots, celery, beetroot, celeriac, etc.	Thoroughly wash the ingredients under lukewarm running water, remove the tops and cut them up into pieces that will pass through the feed tube.
Leafy vegetables, herbs and young wheat (green shoots), etc.	Wash the leafy vegetables and herbs under lukewarm running water. Cut leafy vegetables such as, for example celery, spinach, etc. into pieces about 4–5 cm long. Cut herb bunches such as chives, etc. and young wheat into parts about 3 cm long.
Nuts and soya beans	
Almonds, cashews, hazelnuts, walnuts, etc.	Nuts must always have their shells removed. Before making nut or soya milks, it is necessary to soak the nuts or soya beans in water for at least 8 hours.
Other ingredients	
Water, milk, yoghurt, cream, etc.	These ingredients are added together with the fruit and vegetables, nuts or soya beans into the feed tube to prepare various types of drinks, homemade sorbets and ice creams.

USING THE JUICER

- Prepare the ingredients according to the instructions provided above.
- Make sure that the juicer is correctly assembled and that the control knob **A11** is set to the 0 position (off). Insert the power plug into a power socket.
- Turn on the juicer by setting the control knob **A11** to the required speed.

Speed setting	Type of fruit or vegetable
1 – low speed	Grapes, gooseberries, raspberries, blackberries, bilberries, cherries, kiwi fruit, cucumbers, pomegranate, tomatoes, oranges, mandarins, etc.
2 – medium speed	Leafy vegetables, herbs, young wheat, apples, pears, nectarines, peaches, melons, pineapple, etc.
3 – high speed	Carrot, celery, nuts, frozen pieces of fruit for making sorbets and ice creams, etc.

- Gradually place the prepared ingredients into the feed tube. If they are not pulled in by the pressing auger **A3** into the juicing mechanism, e.g. apples with slippery peels, use the pusher **A1** to push them through the feed tube. You will achieve maximum juice extraction yield by inserting the ingredients gradually and pushing them down gently with low pressure. The juicing process takes place in two stages, first the ingredients are masticated by the pressing auger **A3** and then they are pressed through a strainer. The process cannot be sped up by pushing ingredients through quickly. Otherwise, the juicer may become clogged by a large amount of ingredients.



Attention:

Do not use fingers or other utensils to push ingredients through the feed tube. Always use the pusher **A1** designed for this purpose. The maximum continuous operating time is 60 minutes. Then allow the appliance to cool down for 30 minutes.

- The pulp is released into the pulp container **A13** that is ready underneath the pulp ejection chute **A8** and the pressed juice flows into the juice container **A14** or a glass that is ready underneath the juice spout **A9**. If one of the containers fills up during the juicing process, close the juice spout **A9** and turn off the juicer by setting the control knob **A11** to position 0 (Off). Empty out the given container and put it back in its place. Then you can continue juicing.
- When juicing one type of ingredient, we recommend leaving the juice spout open during the juicing process to enable the juice to freely flow into the juice container **A14** or glass located underneath the juice spout **A9**.
- When juicing various types of ingredients at the same time, or preparing a smoothie, nut or soya milks, or cocktails with the addition of yoghurt or milk, the closable juice spout **A9** enables the ingredients inside the juicing chamber **A7** to be blended together. Then simply open the plug and release the blended drink into the juice container **A14** or a glass located under the juice spout **A9**. Regularly check the juice level in the juicing chamber **A7** and make sure that it does not overflow past the maximum mark.
- When preparing sorbets and ice cream using the homogenisation insert **A6**, the resulting mixture is ejected only through the pulp ejection chute **A8**.
- In the event that the juicing mechanism jams during operation, set the control knob **A11** to the "REVERSE" position (reverse motor direction). Hold it in this position for 15 to 20 seconds to release the jammed ingredients. Then release it. The control knob **A11** will return to position 0 (Off). Set the desired speed to process the released ingredients. You may repeat this procedure several times.
- If you wish to juice various types of ingredients one after another without blending the flavours of various ingredients together; simply quickly rinse the juicing mechanism with clean water without completely disassembling the juicer, in the following manner: Prior to juicing further ingredients, close the juice spout **A9**. Pour 200 ml of clean water through the feed tube into the juicing chamber **A7**. Allow the juicer to run for approx. 1 minute and then release the water into the juice container **A14** located underneath the juice spout **A9**. Now the juicing mechanism is cleaned and you may commence juicing other ingredients.
- When you have finished using the juicer, we recommend that you flush out any remaining ingredients from the juicing mechanism according to the procedure described in the preceding paragraph. This will make the subsequent cleaning of disassembled parts easier. Then turn off the juicer by setting the control knob to position 0 and disconnect the plug from the power socket. Before removing the juice container **A14** or glass located underneath the juice spout **A9**, close the plug to prevent juice from dripping.
- After every use, disassemble the juicer according to the instructions contained in chapter Disassembling the juicer, and clean it out according to the instructions contained in chapter Cleaning and maintenance.

USEFUL ADVICE AND TIPS

- To make juice with a lower pulp content, use the fine strainer **A4**.
- To make juice with a higher pulp fibre content and for juicing softer types of fruit and vegetables, such as for example currants, raspberries, bilberries, tomatoes, etc., use the coarse strainer **A5**. Using the coarse strainer **A5** is particularly important when processing a larger amount of currants.
- Mangoes and bananas are not particularly suitable for juicing because they have a very low juice content. They may, however, form the ideal base ingredients when preparing fruit ice creams and sorbets with the use of the homogenisation insert **A6**.
- To achieve optimal results, always process only fresh ripened fruits and vegetables. Override or unripe fruits and vegetables are not suitable for juicing and will negatively affect the resulting taste of the juice.
- To prevent losing valuable minerals, we recommended consuming the juice immediately after it is pressed.

DISASSEMBLING THE JUICER

- Before disassembling the juicer, make sure that it is turned off, disconnected from the power socket and that the rotating parts are not moving.
- Remove the juice container **A14** and the pulp container **A13**. Turn the lid **A2** anticlockwise and remove it from the juicing chamber **A7**.
- Lift the juicing chamber **A7**, with the strainer and the pressing auger **A3** inside, out of the motor unit **A10**.
- Remove the pressing auger **A3** and strainer out of the juicing chamber **A10**.

CLEANING AND MAINTENANCE

- Clean out the juicer after every use. Before cleaning the juicer, make sure that it is turned off, disconnected from the power socket and that the rotating parts are not moving.
- Disassemble the juicer and thoroughly wash the removable parts in warm water with neutral dishwashing detergent and then dry thoroughly with a wiping cloth. To make the removal of the pulp remains easier, remove the seal ring from the hole located underneath the juicing chamber **A7** in the pulp ejection chute **A8**. It is important not to forget to close the seal ring after cleaning. Thoroughly wash the strainer under running warm water using a neutral kitchen detergent and a cleaning brush **A15**. View it against light to check that the holes in the strainer are clean. If you are unsuccessful in cleaning out the holes, soak the strainer in warm water with the addition of lemon juice and then wash again. Finally, rinse the strainer under running water and thoroughly wipe dry with a wiping cloth. All removable parts are suitable for washing in a dishwasher. Place them in the upper rack of the dishwasher.



Note:

For easier cleaning, immediately wash all the removable parts that come into contact with food. Dried on juice and pulp residues may clog the holes in the strainer and thereby reduce juicing efficiency when used next time.

- If the surface of the motor unit **A10** is dirty, it can be wiped using a dampened cloth. Then dry everything thoroughly. Never submerge the motor unit **A10** or its power cord in water or rinse it under running water.
- For cleaning, do not use cleaning products with an abrasive effect, solvents, etc. Otherwise, the cleaned surface may be damaged.

STORAGE

- When not using the appliance, store it in a dry place out of children's reach. You can store the appliance assembled.

TROUBLESHOOTING

Problem	Possible cause and solution
The juicer does not run when started.	Check that it is connected to a working power socket Check that it is correctly assembled.
The juicer stopped during operation.	The juicer may have been clogged by a large amount of ingredients or excessively hard ingredients. Add ingredients into the juicer gradually and push them through gently with mild pressure. The juicer is not suitable for processing excessively hard ingredients, e.g. sugar cane. The juicer has been running for too long. After approximately 60 minutes of operation, allow it to cool down for approximately 30 minutes.

Juice is leaking out of the bottom of the juicing chamber A7 .	The silicone seal ring on the underside of the juicing chamber A7 is not securely closed. Turn off the juicer, disconnect it from the power socket and disassemble it. Close the seal ring located on the underside of the juicing chamber A7 .
The juicer is vibrating slightly during operation.	Slight vibrations are caused by the effect of juicing hard ingredients.
A noise can be heard during operation.	Make sure that the juicer is located on an even, dry and stable surface. When juicing hard ingredients the noise made is louder than when juicing soft ingredients. Make sure that the juicer is not clogged with an excessive amount of ingredients.
The lid A2 cannot be removed after you have finished using the juicer.	This may be caused by large amounts of pulp residues inside the juicing mechanism or the ingredients may have jammed inside. Do not attempt to disassemble the lid A2 by force! Start the juicer to remove pulp remains from the juicing mechanism, or run it in reverse motor direction for 15 to 20 seconds to release any jammed ingredients and return them to the feed tube. Then start normal operation to process the released ingredients.

RECIPES

DRINK FROM YOUNG WHEAT

100 g of young wheat

- Cut young wheat bunches into 3 cm long parts. Use the fine strainer **A4** and gradually insert the wheat into the juicer. Serve immediately.
- Freshly pressed juice from young wheat is a good source of enzymes and minerals, supports immunity, acts positively on the digestive tract and is a good supplement for treating high blood pressure and cholesterol.

BANANA-STRAWBERRY SORBET

3x ripe bananas

3x ripe strawberries

fresh fruits of the forest and mint leaves for garnish

- Peel the banana and cut it up into circles. Wash the strawberries, remove their stems and cut them into pieces. Spread the banana and strawberries on to a container lined with parchment paper and place in the freezer for 4 to 5 hours.
- Using the homogenisation insert **A6**, process the banana slices and strawberry pieces in the juicer. You may leave the juice spout **A9** closed. The freshly made sorbet will be pushed out through the pulp ejection chute **A8**. If the mixture is not sufficiently homogeneous, allow it to go through the juicer again. Serve the created sorbet in small bowls and garnish with fresh fruits of the forest and mint leaves.

ALMOND MILK

100 g of sweet almonds (unpeeled)

200 ml of water

- Soak the almonds in water for approximately 12 hours. The longer that they soak, the smoother will be the milk. When soaking the almonds for extended periods, it is good to rinse them every few hours to prevent the liquid from fermenting. The soaking time should not exceed 24 hours. Strain the water and add 200 ml of fresh cold water to the swollen almonds. Start the juicer with the fine strainer **A4** installed. Leave the juice spout **A9** closed and use a ladle to pour the water with the almonds into the feed tube. When the juicing chamber **A7** is full, release the milk into the juice container **A14**. If you strain the almond milk through a textile bag intended for plant milk production, you will achieve an even finer consistency. Almond milk is a good source of vitamins, trace elements, calcium and other minerals, and is therefore an excellent alternative to dairy milk. You may flavour it with, for example, maple syrup.
- Consume the freshly-made milk immediately, though no later than within 24 hours. Its nutritional value declines with storage. If you do not consume it immediately, place it in the fridge in a closed glass container.
- Prepare other types of nut milks in the same way. The separated crushed material can be used for preparing desserts, biscuits, cakes, etc.

SOYA MILK

100 g of soya beans

1 l of water

- Soak the soya beans in water for approximately 8 to 10 hours. Strain the water and add 1 l of fresh cold water to the swollen soya beans. Start the juicer with the fine strainer **A4** installed. Leave the juice spout **A9** closed and use a ladle to pour the water with the soya beans into the feed tube. When the juicing chamber **A7** is full, release the milk into the juice container **A14**. Strain the soya milk into a larger pot through a textile bag intended for plant milk production. Bring the milk to a boil. Then allow it to simmer for approximately 20 to 30 minutes at low heat, so that foam is not created. Once it has cooled down, the milk may be consumed. Place unconsumed milk enclosed in a glass container into a refrigerator for up to 24 hours.
- Soya milk does not contain lactose or cholesterol, it contains fibre including soluble prebiotic oligosaccharides, which support the growth of probiotics.

HOMEMADE STRAWBERRY ICE CREAM

250 g of strawberries

100 g of cream

2 tablespoons of white yoghurt

50 g of sugar (maple syrup can be used instead of sugar)

2 tablespoons of lemon juice

- Wash the strawberries, remove the stems and cut into pieces. Spread them out on a container lined with parchment paper and place in the freezer for approximately 5 hours. Mix the remaining ingredients together and place them in the freezer for the same period of time. When removed from the freezer, the mixture must be sufficiently firm. Using the homogenisation insert **A6**, process the strawberries and the mixture. Put the ingredients in alternately. You may leave the juice spout **A9** closed. The freshly made ice cream will be pushed out through the pulp ejection chute **A8**. If it is not sufficiently homogeneous, allow it to go through the juicer again. Serve the ice cream in small bowls.

TECHNICAL SPECIFICATIONS

Rated voltage range.....	220–240 V
Rated frequency.....	50 Hz
Rated power input.....	200 W
Noise level	63 dB(A)

The declared noise emission level of the appliance is 63 dB(A), which represents a level A of acoustic power with respect to a reference acoustic power of 1 pW.

Changes to text and technical parameters are reserved.

INSTRUCTIONS AND INFORMATION REGARDING THE DISPOSAL OF USED PACKAGING MATERIALS

Dispose of used packaging material at a site designated for waste in your municipality.

DISPOSAL OF USED ELECTRICAL AND ELECTRONIC EQUIPMENT



This symbol on products or original documents means that used electric or electronic products must not be added to ordinary municipal waste. For proper disposal, renewal and recycling hand over these appliances to determined collection points. Alternatively, in some European Union states or other European countries you may return your appliances to the local retailer when buying an equivalent new appliance.

Correct disposal of this product helps save valuable natural resources and prevents potential negative effects on the environment and human health, which could result from improper waste disposal. Ask your local authorities or collection facility for more details.

In accordance with national regulations penalties may be imposed for the incorrect disposal of this type of waste.

For business entities in European Union states

If you want to dispose of electric or electronic appliances, ask your retailer or supplier for the necessary information.

Disposal in other countries outside the European Union

This symbol is valid in the European Union. If you wish to dispose of this product, request the necessary information about the correct disposal method from the local council or from your retailer.



This product meets all the basic requirements of EU directives related to it.