

NINJA®

Foodi®

MAX PRO

Health Grill,
Flat Plate &
Air Fryer

AG651UK

INSTRUCTIONS



ninjakitchen.co.uk

THANK YOU

for purchasing the Ninja® Foodi® Max Pro Health Grill, Flat Plate & Air Fryer



REGISTER YOUR PURCHASE



ninjakitchen.co.uk/registerguarantee



Scan QR code using mobile device

RECORD THIS INFORMATION

Model Number: _____

Serial Number: _____

Date of Purchase: _____
(Keep receipt)

Store of Purchase: _____

TECHNICAL SPECIFICATIONS

Voltage: 220-240V~ 50-60Hz

Watts: 2460W

TIP: You can find the model and serial numbers on the QR code label on the back of the unit by the power cord.

PRODUCT REGISTRATION: Please visit ninjakitchen.co.uk or call 0800 862 0453 to register your new Ninja® product within 28 days of purchase. You will be asked to provide the store name, date of purchase, and model number along with your name and address.

The registration will enable us to contact you in the unlikely event of a product safety notification.

CONTENTS

Product Registration	2
Important Safeguards	4
Parts	6
Getting to Know Your Grill	7
Function Buttons	7
Operating Buttons	7
Before First Use	7
Using the Ninja® Foodi® Max Pro	8
Splatter Guard	8
Grill Control	8
Batch Grilling	8
Using the Digital Cooking Probe.....	9
Using the Probe in Different Cooking Scenarios	10
How to Insert the Probe.....	11
Cooking Functions	12
Grill	12
Flat Plate	12
Roast	14
Air Fry	15
Bake	16
Dehydrate	16
Reheat	17
Cleaning & Maintenance	18
Troubleshooting	19

IMPORTANT SAFEGUARDS

HOUSEHOLD USE ONLY • READ ALL INSTRUCTIONS BEFORE USE

When using electrical appliances, basic safety precautions should always be followed, including the following:

⚠ WARNING

- 1** To eliminate a choking hazard for young children, discard all packaging materials immediately upon unpacking.
- 2** This appliance can be used by persons with reduced physical, sensory or mental capabilities or lack of experience and knowledge if they have been given supervision or instruction concerning use of the appliance in a safe way and understand the hazards involved.
- 3** Keep the appliance and its cord out of reach of children. **DO NOT** allow the appliance to be used by children. Close supervision is necessary when used near children.
- 4** This appliance is for household use only. **DO NOT** use this appliance for anything other than its intended use. **DO NOT** use in moving vehicles or boats. **DO NOT** use outdoors. Misuse may cause injury.
- 5** Ensure the surface is level, clean and dry. **DO NOT** place the appliance near the edge of a worktop during operation.
- 6** **ALWAYS** ensure the appliance is properly assembled before use.
- 7** When using this appliance, provide at least 15cm of space above and on all sides for air circulation.
- 8** **DO NOT** use an extension cord. A short power-supply cord is used to reduce the risk of children grabbing the cord or becoming entangled and to reduce the risk of people tripping over a longer cord.
- 9** To protect against electrical shock **DO NOT** immerse cord, plugs, or main unit housing in water or other liquid.
- 10** **DO NOT** use the appliance if there is damage to the power cord or plug. Regularly inspect the appliance and power cord. If the appliance malfunctions or has been damaged in any way, immediately stop use and call Customer Service.
- 11** **NEVER** use socket below worktop surface.
- 12** **DO NOT** place appliance on hot surfaces including on or near a gas or electric burner or in a heated oven.
- 13** **DO NOT** let cord hang over edges of tables or worktops.
- 14** Only use recommended accessories included with this appliance or authorised by SharkNinja. The use of accessories or attachments not recommended by SharkNinja may cause a risk of fire or injury.
- 15** Before placing any accessory into the cooker, ensure it is clean and dry.
- 16** **DO NOT** use the appliance without the grill plate and splatter guard installed.
- 17** **ALWAYS** ensure lid is fully closed before operating.
- 18** **DO NOT** move the appliance when in use.
- 19** **DO NOT** cover the air intake vent or air socket vent while unit is operating. Doing so will prevent even cooking and may damage the unit or cause it to overheat.
- 20** **DO NOT** touch hot surfaces. Appliance surfaces are hot during and after operation. To prevent burns or personal injury, **ALWAYS** use protective hot pads or insulated oven gloves and use available handles and knobs.

- 21 DO NOT** touch accessories during or immediately after cooking. The grill plate and basket becomes extremely hot during the cooking process. Avoid physical contact while removing the accessory from the appliance. To prevent burns or personal injury **ALWAYS** use care when using product. Recommend use of long handed utensil and protective hot pads or insulated oven gloves.
- 22 DO NOT** use this appliance for deep-frying.
- 23 DO NOT** place hands near the Digital Cooking Probe cord when in use to prevent burning or scalding.
- 24** We recommend that you confirm the internal temperature of food using an external food probe.
- 25** Please refer to the Cleaning & Maintenance section for regular maintenance of the appliance.
- 26** To disconnect, turn any control to "off", then unplug from socket when not in use and before cleaning.
- 27** Allow to cool before cleaning, disassembly, putting in or taking off parts and for storage.
- 28 DO NOT** clean with metal scouring pads. Pieces can break off the pad and touch electrical parts, creating a risk of electric shock.
- 29** Cleaning and user maintenance should not be performed by children.
- 30** Extreme caution must be used when moving an appliance containing hot oil or other hot liquids.
- 31 DO NOT** place anything on top of the product when the lid is closed during use and stored.
- 32** Ensure the grill plate is correctly inserted and securely locked into position.
- 33** Always ensure the grill is completely cool before releasing and removing the cooking plates.



Indicates to read and review instructions to understand operation and use of product.



Indicates the presence of a hazard that can cause personal injury, death or substantial property damage if the warning included with this symbol is ignored.



Take care to avoid contact with hot surface. Always use hand protection to avoid burns.



For indoor and household use only.

SAVE THESE INSTRUCTIONS

PARTS

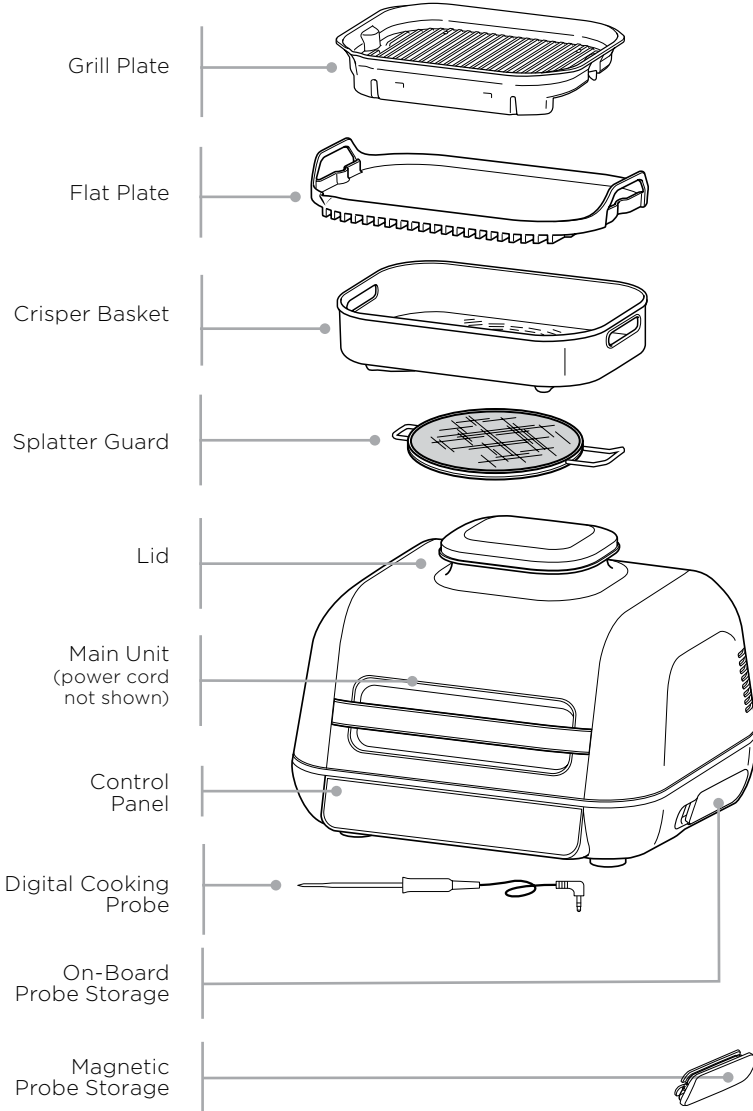

GETTING TO KNOW YOUR GRILL

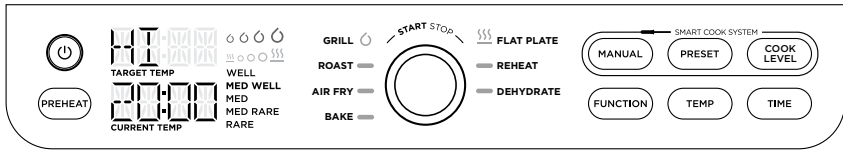

NOTE: Not all functions included with every model.

FUNCTION BUTTONS

GRILL Closed-lid cooking: Top and bottom heat which is best for grilling large or thick cuts of meat, frozen food or for an all-around sear.

Open lid cooking: Ideal for grilling delicate foods or lean proteins to develop char-grilled textures without over-cooking.

ROAST Tenderise meats, roast vegetables and more.

AIR FRY For crispiness and crunch with little to no oil.

BAKE Make cakes, treats, desserts and more.

FLAT PLATE Perfect for delicate foods like onions, eggs, fish or fajitas.

REHEAT Revive leftovers by gently warming them, leaving you with crispy results.

DEHYDRATE Dehydrate meats, fruits and vegetables for healthy snacks.

MANUAL Switches the display so you can manually set the internal outcome with the dial.

PRESET When probe is inserted, the display will allow you to select your food type. Turn the dial to select your protein.

COOK LEVEL Cook to your preference, choose from Rare to Well Done.

BEFORE FIRST USE

- 1 Remove all packaging material, promotional labels and tape from the unit.
- 2 Remove all accessories from the package and read this manual carefully. Please pay particular attention to operational instructions, warnings and important safeguards to avoid any injury or property damage.
- 3 Wash the grill plate, flat plate, crisper basket, probe and splatter guard in warm, soapy water, then rinse and dry thoroughly. All accessories, except the probe and probe storage, are dishwasher safe. **NEVER** clean the main unit or probe in the dishwasher.
- 4 Do not use abrasive brushes or sponges on the cooking surfaces, as they will cause damage to the coating.

OPERATING BUTTONS

⏻ POWER Make sure unit is plugged in. To turn on the unit, press the ⏻ button.

DIAL To select a cooking function or other setting, turn the dial ⌚.

START/STOP Press the centre of the dial to start or stop the selected cooking function. When most cooking functions are started, the unit enters preheat mode, then cooking begins when the temperature setting is reached.

TEMP To select temperature, press the **TEMP** button and use the dial to adjust.

TIME To select cook time, press **TIME** button and use the dial to adjust.

FUNCTION Press to clear all settings or when probe is in "Rest" state (if preheating and cooking have not begun).

PREHEAT After you set function, time and temperature then press the dial, the unit will automatically begin preheating. If **PREHEAT** button is selected after pressing dial, the unit will skip preheating (not recommended).

PREHEAT FOR BETTER RESULTS For best grilling results, let the unit fully preheat before adding food. Adding food before preheating is complete may lead to overcooking, smoke and longer preheat time.

USING THE NINJA® FOODI® MAX PRO

SPLATTER GUARD

Located on the underside of the lid, the splatter guard keeps the heating element clean. **ALWAYS** ensure the splatter guard is installed when cooking. Failure to use the splatter guard will result in oil build-up on the heating element, which can cause smoking.

Installing the splatter guard

To install, hook the left side of the splatter guard into place and then snap the right side into place until you hear it click and it feels secure.

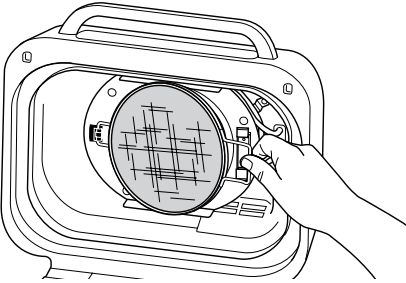

Removing the splatter guard

Remove the splatter guard for cleaning after each use. Allow the shield to cool completely, then unhook the shield from the back of the lid by pressing the top tab back, then pull handle forward.

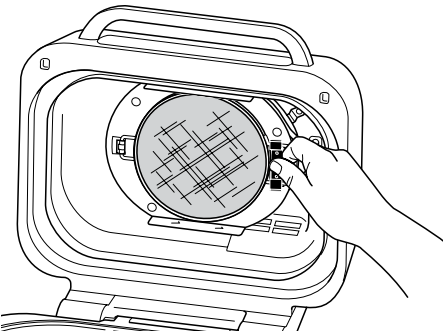

GRILL CONTROL

Closed-lid cooking for top and bottom heat. Best when grilling large or thick cuts of meat or frozen food or for an all-around sear.

When using the Grill function, you will need to select the temperature for the grill plate. Below are recommended temperature levels for common ingredients. **The unit may produce smoke when cooking ingredients on a setting hotter than recommended.**

LOW (200°C)	MED (230°C)	HI (250°C)	MAX (260°C)
<ul style="list-style-type: none">• Bacon• Sausages• When using thick BBQ sauce	<ul style="list-style-type: none">• Frozen meats• Marinated/sauced meats• Burgers	<ul style="list-style-type: none">• Steaks• Chicken• Hot dogs• Meat kebabs	<ul style="list-style-type: none">• Veggies• Fruit• Pizzas• Fresh/frozen seafood• Veggie Kebabs

Switching to Grill after using another function

If the unit is already warm from using a different function, "ADD FOOD" may appear on the screen immediately. We recommend allowing the grill plate to heat up for at least 6 minutes before placing ingredients on it.

Batch grilling

When grilling more than two consecutive batches of food, it is recommended that you empty the fat/oil from the removable cooking pot. It is also HIGHLY recommended to clean the splatter guard in between uses. This will help prevent grease from burning and causing smoke.

USING THE NINJA® FOODI® MAX PRO - CONT.

USING THE DIGITAL COOKING PROBE

IMPORTANT: DO NOT place hands near Digital Cooking Probe cord when in use to prevent burning or scalding.

Before First Use

Make sure the probe jack is free of any residue and the cord is free of knots before plugging it into the socket. Handle cord with care.

- 1 Pull the magnetic probe storage compartment on the right side of the unit outward. Then unwind the wire from the compartment to remove the probe.

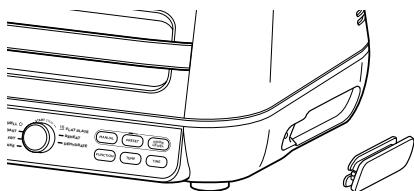

- 2 Plug the probe into the input jack on the right hand side of the unit. Push firmly on the plug until it cannot go into the jack any further and you feel or hear it click into place. Place the storage compartment back onto the side of the unit.

- 3 Once the probe is plugged into the jack, it will enable and illuminate the PRESET and MANUAL probe buttons. Turn the dial to select the desired cook function (e.g., Grill) and cook temperature.

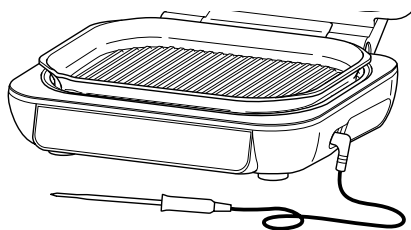

NOTE: There is no need to set a cook time, as the unit will automatically turn off the heating element and alert you when your food has completed cooking.

- 4 If using PRESET, then press the **PRESET** button and turn the centre dial to select your desired food type. Upon selection, press the **COOK LEVEL** button and turn the dial to choose your preferred internal outcome of your food (rare to well done).

NOTE: Cooking different meats or to different preferences? Refer to page 10 for details on programming.

WELL
MED WELL
MED
MED RARE
RARE

If using MANUAL, then press the **MANUAL** button and use the below recommended internal cook temperatures.

FOOD TYPE:	SET LEVEL TO:
Fish	Medium Rare (50°C)
	Medium (55°C)
	Medium Well (60°C)
	Well Done (65°C)
Chicken/Turkey	Well Done (75°C)
Pork	Medium Rare (50°C)
	Medium (55°C)
	Medium Well (65°C)
	Well Done (70°C)
Beef/Lamb	Rare (50°C)
	Medium Rare (55°C)
	Medium (60°C)
	Medium Well (65°C)
	Well Done (70°C)

NOTE: Refer to the UK Food Standards Agency for recommended food safe temperatures.

NOTE: Preset cooking levels for BEEF/LAMB are lower than normal recommendations as unit will carry-over cook 5-10°C.

USING THE NINJA® FOODI® MAX PRO - CONT.

- Place the accessory required for your selected cook function in the unit and close the lid. Press the dial to begin preheating.
- While the unit is preheating, insert the probe horizontally into the centre of the thickest part of the piece of protein.
Refer to the chart on the adjacent page on further probe placement instructions.
- When the unit has preheated and “ADD FOOD” appears on the screen, open the lid, place food with inserted probe in the unit and close the lid over the probe cord if the function requires the lid to be closed.

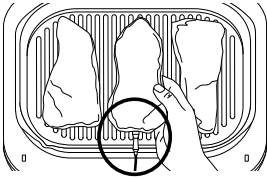

Correct probe placement.
Probe grip is fully inside unit.

- The progress bar at the top of the display will track the stages of cook. Flashing indications progression to that stage.

WELL
MED WELL
MED
MED RARE
RARE

NOTE: When using Grill, Flat Plate, Roast and Air Fry, the unit will beep and display FLIP. Flipping is optional but recommended

- The unit will automatically stop when your selection is almost reached, as it accounts for carry-over cooking and GET FOOD will display on the screen.
- When REST displays on the screen, transfer the protein to a plate. Probe can be removed before transferring. The protein will continue to carry-over cook to your set outcome, which takes about 3–5 minutes. This is an important step, as not resting could lead to results looking less cooked. Carry-over cook times can vary based on size of protein, cut of protein and type of protein.

NOTE: The probe will be HOT. Use either oven gloves or tongs to take the probe out of the food.

NOTE: To check the internal temperature of other pieces of protein, press and hold MANUAL and insert the probe into each piece of meat.

USING THE PROBE IN DIFFERENT COOKING SCENARIOS:

Cooking 2 or more proteins of the same size to different levels of outcome:

- Set the cook level to the highest required.
- Insert the probe in the protein with the highest desired cook level.
- After preheating, place proteins inside the grill. When the progress bar shows that the lowest cook level is reached, remove the protein without probe.
- Continue cooking the remaining protein until the next desired cook level is reached.

Cooking 2 or more proteins of different sizes:

- Insert probe in the smaller protein and use the Preset feature to choose the level of outcome.
- When that protein is cooked, remove it from the unit.
- Using oven gloves, transfer probe to the larger protein and use the arrows to the left of the display to choose its level of outcome.



Cooking 2 or more different types of protein:

- Insert probe in the protein with the lower desired level of outcome.
- Use the Manual feature to choose the desired internal temperature.
- When that protein is cooked, remove it from the unit.
- Using oven gloves, transfer probe to the other protein and use the Manual feature to choose the desired internal temperature.

USING THE NINJA® FOODI® MAX PRO - CONT.

HOW TO INSERT THE PROBE

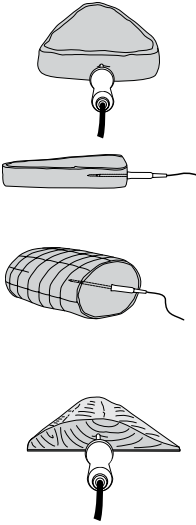
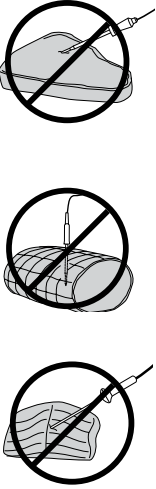
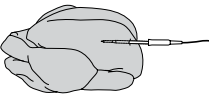
NOTE: DO NOT use the probe with frozen foods or for cuts of meat thinner than 1.5cm.

FOOD TYPE:	PLACEMENT	CORRECT	INCORRECT
<p>Steaks Pork chops Lamb chops Chicken breasts Burgers Tenderloins Fish fillets</p>	<ul style="list-style-type: none"> • Insert probe horizontally into the centre of the thickest part of the meat. • Make sure the tip of the probe is inserted straight into the centre of the meat, not angled toward the bottom or top of it. • Make sure the probe is close to (but not touching) the bone and away from any fat or gristle. <p>NOTE: The thickest part of the fillet may not be the centre. It is important that the end of the probe hits the thickest part so desired results are achieved.</p>		
<p>Whole chicken</p>	<ul style="list-style-type: none"> • Insert probe horizontally into the thickest part of the breast, parallel to, but not touching, the bone. • Make sure the top reaches the centre of the thickest part of the breast and doesn't go all the way through the breast into the cavity. 		

COOKING FUNCTIONS

Grill

Cook with lid open for bottom heat only, best for cooking delicate foods and lean proteins such as kebabs or vegetables.

Cook with lid closed for top and bottom heat which is best for thick cuts or frozen proteins.

- 1 To install the grill plate, position it in the front of the base so it hooks in, then press down on the back of the plate until it clicks in place. Ensure the splatter guard is in place, then close the lid.

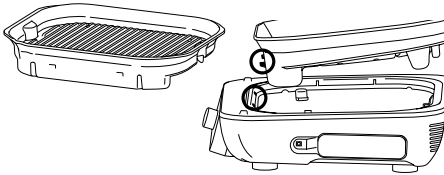

- 2 Make sure the unit is plugged in and press  to turn the unit on. Grill will be selected by default.
- 3 The default temperature setting will display. To adjust temperature if desired, press **TEMP** button and turn dial.
- 4 Press the **TIME** button and turn the dial to select the desired time.
- 5 Press dial to begin preheating. The progress bar will illuminate. It will take approximately 4-7 minutes to preheat.
- 6 When preheating is complete, the unit will beep and **ADD FOOD** will appear on the display.
- 7 Open the lid and place ingredients on the grill plate. Close the lid when cooking thick cuts of meats, frozen protein. Keep lid open when cooking delicate food or lean proteins.
- 8 When cook time is complete, the unit will beep and **END** will appear on the display.
- 9 Remove food from the grill plate.
- 10 Remove the grill plate by pressing the orange release button on the left side of the unit. The plate will pop up from the back, then you can lift it up and out.

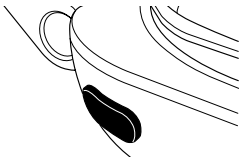

Flat Plate

Cook with lid open with heat from the bottom for foods that require flipping or stirring and constant attention like sliced vegetables or fried eggs.

Cook with lid closed for top and bottom heat, ideal for melting cheese, crisping toppings or quickly cooking thicker foods.

- 1 To install the grill plate, position it in the front of the base so it hooks in, then press down on the back of the plate until it clicks in place. Ensure the splatter guard is in place.

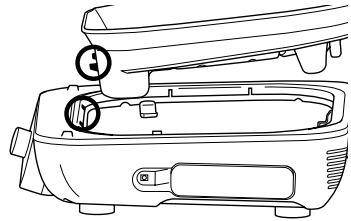

- 2 Place flat plate on the grill so plate sits level. Line up the lip on the flat plate with the lip on the grill plate (if incorrectly installed it will tilt forward). Close the lid.

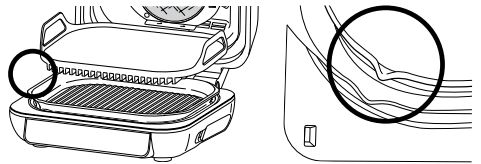

- 3 Make sure the unit is plugged in and press  to turn the unit on.
- 4 Turn the dial to **FLAT PLATE** function. The default temperature setting will display. To adjust temperature if desired, press **TEMP** button and turn dial.
- 5 Press the **TIME** button and turn the dial to select the desired time.
- 6 Press the dial to begin preheating. The progress bar will illuminate. It will take approximately 7-9 minutes to preheat.

PRE

COOKING FUNCTIONS - CONT.

- 7** When preheating is complete, the unit will beep and ADD FOOD will appear on the display.
- 8** Open the lid and place ingredients on the flat plate. The countdown timer has a 15-second delayed start. Leave lid open unless recipe directs otherwise.

NOTE: If batch cooking meats, for best results, we recommend in between batches to close the lid and run the programmed function for 2-3 minutes before adding more food.

- 9** When cook time reaches zero, the unit will beep and END will appear on the display.
- 10** Remove food from the flat plate, then remove the flat plate from the grill plate.
- 11** Remove the grill plate by pressing the orange release button on the left side of the unit. The plate will pop from the back then lift up.

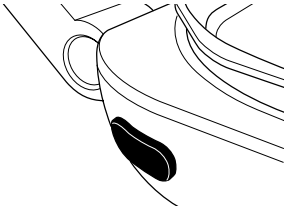

COOKING FUNCTIONS - CONT.

Roast

- 1 To install the grill plate, position it in the front of the base so it hooks in, then press down on the back of the plate until it clicks in place. Ensure the splatter guard is in place, then close the lid.

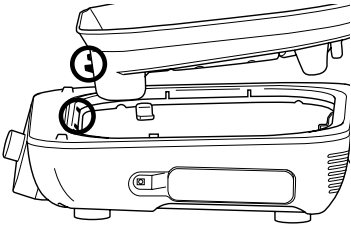
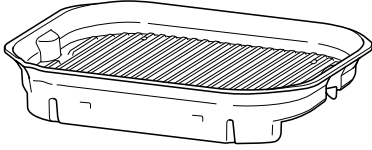

- 2 Make sure the unit is plugged in and press  to turn the unit on.
- 3 Turn the dial to **ROAST**. The default temperature setting will appear on the display. To adjust temperature if desired, press **TEMP** button and turn dial.
- 4 Press the **TIME** button and turn the dial to select the desired time.
- 5 Press the dial to begin preheating. The progress bar will begin illuminating. It will take approximately 3 minutes to preheat.

NOTE: While preheating is strongly recommended for best results, you can skip it by pressing the **PREHEAT** button. **ADD FOOD** will appear on the display.

- 6 When preheating is complete, the unit will beep and **ADD FOOD** will appear on the display.
- 7 Open the lid and place ingredients on the grill plate. Once the lid is closed, cooking will begin and the timer will begin counting down.
- 8 When cook time reaches zero, the unit will beep and **END** will appear on the display.
- 9 Remove food from the grill plate.
- 10 Remove the grill plate by pressing the orange release button on the left side of the unit. The plate will pop from the back, then lift up.



COOKING FUNCTIONS - CONT.

Air Fry

- 1 To install the grill plate, position it in the front of the base so it hooks in, then press down on the back of the plate until it clicks in place. Ensure the splatter guard is in place.

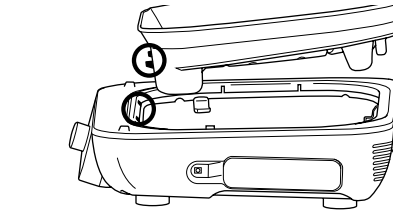
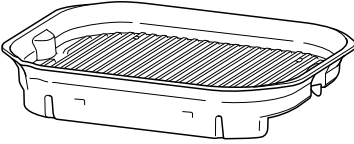

- 2 Place the crisper basket on the plate and position the basket to sit along the rear of the grill plate so the basket feet sit in the grill plate spaces, then close the lid.

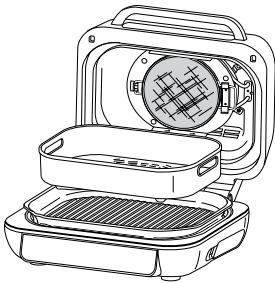

- 3 Make sure the unit is plugged in and press  to turn the unit on.
- 4 Turn the dial to **AIR FRY**. The default temperature setting will appear on the display. To adjust temperature if desired, press **TEMP** button and turn dial.
- 5 Press the **TIME** button and turn the dial to select the desired time.

- 6 Press the dial to begin preheating. The progress bar will illuminate. It will take approximately 3 minutes to preheat.
- 7 When preheating is complete, the unit will beep and **ADD FOOD** will appear on the display.

NOTE: While preheating is strongly recommended for best results, you can skip it by pressing the **PREHEAT** button. Display will show **ADD FOOD**, lift and close lid to begin cooking.

- 8 Open the lid and place ingredients in the crisper basket. Once the lid is closed, cooking will begin and the timer will start counting down.
- 9 For best results, we recommend shaking ingredients frequently. When you open the lid, the unit will pause. Use silicone-tipped tongs or oven gloves to shake the basket. When done, replace the basket and close the lid. Cooking will automatically resume after lid is closed.
- 10 When cook time reaches zero, the unit will beep and **END** will appear on the display.
- 11 Remove crisper basket from the grill plate.
- 12 Remove the grill plate by pressing the orange release button on the left side of the unit. The plate will pop from the back, then lift up.

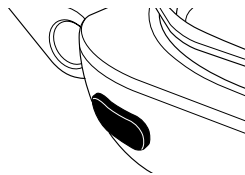

COOKING FUNCTIONS - CONT.

Bake

- 1 To install the grill plate, position it in the front of the base so it hooks in, then press down on the back of the plate until it clicks in place. Ensure the splatter guard is in place, then close the lid.

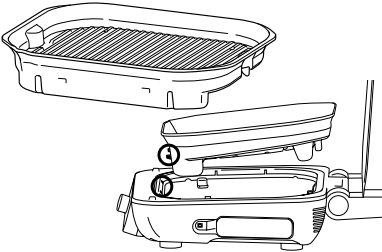

- 2 Make sure the unit is plugged in and press  to turn the unit on.
- 3 Turn the dial to **BAKE**. The default temperature setting will appear on the display. To adjust temperature if desired, press **TEMP** button and turn dial.
- 4 Press the **TIME** button and turn the dial to select the desired time.
- 5 Press the dial to begin preheating. The progress bar will begin illuminating. It will take approximately 3 minutes to preheat.

NOTE: While preheating is strongly recommended for best results, you can skip it by pressing the **PREHEAT** button. Display will show **ADD FOOD**, lift and close lid to begin cooking.

- 6 When preheating is complete, the unit will beep and **ADD FOOD** will appear on the display.
- 7 Open the lid and place ingredients on the plate or place loaf tin on the plate. Once the lid is closed, cooking will begin and the timer will start counting down.
- 8 When cook time reaches zero, the unit will beep and **END** will appear on the display.
- 9 Remove food from the grill plate.
- 10 Remove the grill plate by pressing the orange release button on the left side of the unit. The plate will pop up from the back, then you can lift it up and out.

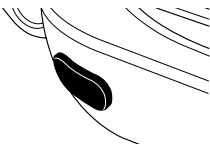

Dehydrate

- 1 To install the grill plate, position it in the front of the base so it hooks in, then press down on the back of the plate until it clicks in place. Ensure the splatter guard is in place.

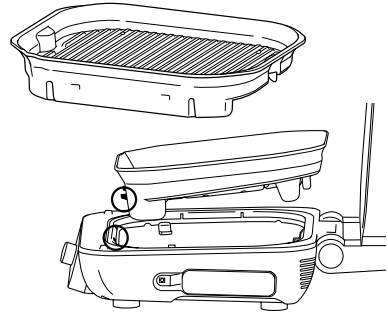

- 2 Place the crisper basket on the grill plate and add ingredients to the basket. Close the lid, as the unit does not require preheating for this function.
- 3 Make sure the unit is plugged in and press  to turn the unit on.
- 4 Turn the dial to **DEHYDRATE** function. The default temperature setting will display. To adjust temperature if desired, press **TEMP** button and turn dial.
- 5 Press the **TIME** button and turn the dial to select the desired time.
- 6 Press the dial to begin. (The unit does not preheat in dehydrate mode.)
- 7 When dehydrate time reaches zero, the unit will beep and **END** will appear on the display.
- 8 Remove ingredients and basket from the grill plate.
- 9 Remove the grill plate by pressing the orange release button on the left side of the unit. The plate will pop up from the back, then you can lift it up and out.



COOKING FUNCTIONS - CONT.

Reheat

- 1 To install the grill plate, position it in the front of the base so it hooks in, then press down on the back of the plate until it clicks in place. Ensure the splatter guard is in place.

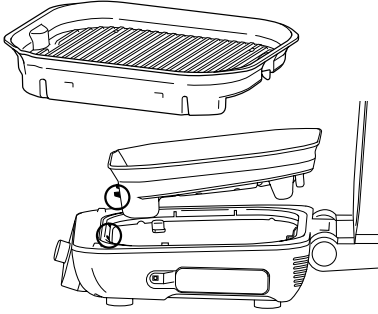

- 2 Place the crisper basket on the plate and position the basket to sit along the rear of the grill plate so the basket feet sit in the grill plate spaces. Add ingredients, then close the lid.

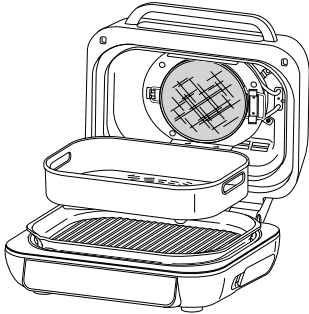

- 3 Make sure the unit is plugged in and press  to turn the unit on.
- 4 Turn the dial to **REHEAT**. The default temperature setting will appear on the display. To adjust temperature if desired, press **TEMP** button and turn dial.

NOTE: If you would like to use the probe to check your food's internal temperature, press **MANUAL** for 2 seconds and the food's internal temp will appear on the screen for 5 seconds.

- 5 Press the **TIME** button and turn the dial to select the desired time. Press the dial to begin (the unit does not preheat in Reheat mode). Cooking will begin and the timer will start counting down.
- 6 For best results, we recommend shaking ingredients frequently. When you open the lid, the unit will pause. Use silicone-tipped tongs or oven gloves to shake the basket and close the lid. Cooking will automatically resume after lid is closed.
- 7 When cook time reaches zero, the unit will beep and **END** will appear on the display.
- 8 Remove crisper basket from the grill plate.
- 9 Remove the grill plate by pressing the orange release button on the left side of the unit. The plate will pop from the back, then lift up.



CLEANING & MAINTENANCE

The unit should be cleaned thoroughly after every use. Always let the appliance cool before cleaning.

- Unplug the unit from the wall socket before cleaning. Keep the lid open after removing your food to allow the unit to cool more quickly.
- The grill plate, flat plate, crisper basket and splatter guard are dishwasher safe. The probe and probe holder are **NOT** dishwasher safe.
- For the best dishwasher cleaning results, we recommend rinsing the grill plate, flat plate, crisper basket and splatter guard with warm water before placing them in the dishwasher.
- If hand-washing, air-dry or towel-dry all parts after hand-washing.
- The inner lid should be wiped down with a damp towel or cloth after each use to deodorise the unit and remove any grease.

NOTE: The Digital Cooking Probe and holder are handwash only. **DO NOT** immerse any part of the probe in water or any other liquid. We recommend cleaning with a damp cloth only.

- If food residue or grease are stuck on the grill plate, splatter guard, or any other removable part, soak in warm soapy water before cleaning.
- Clean the splatter guard after every use. Soaking the splatter guard overnight will help soften the baked-on grease. After soaking, use a cleaning brush to remove the grease from the stainless steel frame and front tabs.
- Deep clean the splatter guard by putting it in a pan of water and boiling it for 10 minutes. Then, rinse with room temperature water and allow to dry completely.
- Gently wipe down the inside of the lid with a damp cloth.

NOTE: NEVER use abrasive tools or cleaners. **NEVER** immerse the main unit in water or any other liquid.

- When stacking your coated accessories to store, place a cloth or paper towel between each piece to protect the coated surfaces.

TROUBLESHOOTING

- **“ADD FOOD” appears on the control panel display.**
The unit has completed preheating and it is now time to add your ingredients.
- **“Shut Lid” appears on the control panel display.**
The lid is open and needs to be closed for the selected function to start.
- **“Plug In” appears on the control panel display.**
The probe is not plugged into the socket on the right side of the control panel. Plug the probe in before proceeding. Press the probe in until you hear a click.
- **“PRBE ERR” appears on the control panel display.**
This means the unit timed out before food reached the set internal temperature. As a protection for the unit, it can run for only certain lengths of time at specific temperatures.
- **“Add Plate” appears on the control panel display.**
The grill plate must be installed in the base unit before cooking. Add the grill plate.
- **“E” appears on the control panel display.**
The unit is not functioning properly. Please contact Customer Service at 0800 862 0453. So we may better assist you, please register your product online at ninjakitchen.co.uk and have the product on hand when you call.
- **Why is my food overcooked or undercooked even though I used the probe?**
It is important to insert the probe lengthwise into the thickest part of the ingredient to get the most accurate reading. Make sure to allow food to rest for 3-5 minutes to complete cooking. For more information, refer to the Using the Digital Cooking Probe section.
- **Why is there no noise during Flat Plate preheat even though the preheat progress bars are showing?**
As long as the progress bar shows, your unit is preheating. Flat Plate will preheat the bottom plate and switch on the fan several minutes into the preheat cycle.
- **Can I cancel or override preheating?**
Preheating is highly recommended for best results, but you can skip it by selecting the PREHEAT button after you press the dial. Display will show ADD FOOD, lift and close lid to begin cooking.
- **Should I add my ingredients before or after preheating?**
For best results, let the unit preheat before adding ingredients.
- **Why is my unit emitting smoke?**
When using the Grill and Flat Plate functions, always select the recommended temperature setting. Recommended settings can be found in the Recipe Guide. Make sure the splatter guard is installed.
- **How do I pause the unit so I can check my food?**
By opening the lid during a cooking function besides Grill and Flat Plate, the unit will automatically pause.
- **Will the probe grip melt if it touches the hot grill plate?**
No, the grip is made of a high-temperature silicone that can handle the unit's high temperatures.
- **Why does the unit have a 1-9 scale for the Beef Preset?**
Perception of how well something is cooked differs. The 1-9 scale provides a wide range of options for each level of cook so you can customise to your liking.
- **Can I use the Flat Top function and flat top accessory after having cooked on the grill plate?**
Yes, but we highly recommend cleaning the grill plate first so there is no debris to interfere with the flat top-to-grill plate contact.

VISIT US ONLINE AT:

ninjakitchen.co.uk

Or follow us on any of our social media pages:



NOTE: Save these instructions. Keep for future reference.



This marking indicates this product should not be disposed of with other household wastes throughout the UK. To prevent possible harm to the environment or human health from uncontrolled waste disposal, recycle it responsibly to promote the sustainable reuse of material sources. To return your used device, please use the return and collection systems or contact the retailer where this product was purchased. They can take this product for environmentally safe recycling.

Euro-Pro Europe Limited
3150 Century Way
Thorpe Park, Leeds
LS15 8ZB, UK
0800 862 0453

ninjakitchen.co.uk

SharkNinja Germany GmbH,
c/o Regus Management GmbH
Excellent Business Center 10.
+ 11/ Stock Westhafenplatz 1,
60327 Frankfurt am Main, Germany

ninjakitchen.eu

Illustrations may differ from actual product. We are constantly striving to improve our products, therefore the specifications contained herein are subject to change without notice.

FOODI and NINJA are registered trademarks of SharkNinja Operating LLC.

© 2021 SharkNinja Operating LLC

PRINTED IN CHINA

AG651UK_IB_MP_210714_Mv2

