

Owner's Manual

CRAFTSMAN®

7-1/4 in. CIRCULAR SAW Double Insulated

Model Nos.
315.108400
315.108410

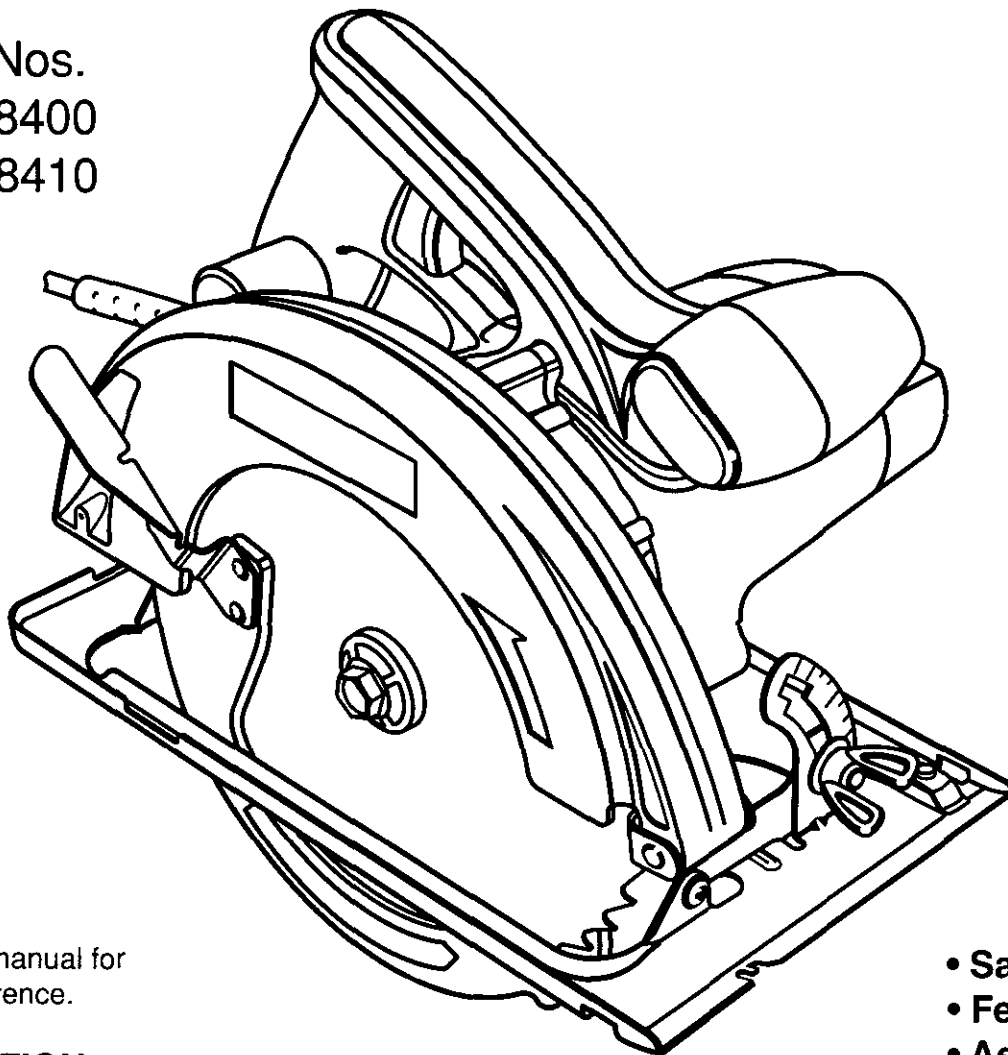

Save this manual for future reference.

⚠ CAUTION: Read and follow all Safety Rules and Operating Instructions before first use of this product.

Customer Help Line: 1-800-932-3188

Sears, Roebuck and Co., Hoffman Estates, IL 60179 USA
Visit the Craftsman web page: www.sears.com/craftsman

972000-823
10-01

- Safety
- Features
- Assembly
- Operation
- Maintenance
- Parts List



TABLE OF CONTENTS

■ Table of Contents	2
■ General Safety Rules	2-3
■ Specific Safety Rules and/or Symbols	3-6
■ Features	7-8
■ Assembly	9-10
■ Operation	11-18
■ Maintenance	18-19
■ Accessories	19
■ Exploded View and Repair Parts List	20-21
■ Parts Ordering / Service	22

GENERAL SAFETY RULES

⚠ WARNING: Read and understand all instructions. Failure to follow all instructions listed below may result in electric shock, fire and/or serious personal injury.

SAVE THESE INSTRUCTIONS

Work Area

- **Keep your work area clean and well lit.** Cluttered benches and dark areas invite accidents.
- **Do not operate power tools in explosive atmospheres, such as in the presence of flammable liquids, gases, or dust.** Power tools may create sparks which may ignite the dust or fumes.
- **Keep bystanders, children, and visitors away while operating a power tool.** Distractions can cause you to lose control.

Electrical Safety

- **Double insulated tools are equipped with a polarized plug (one blade is wider than the other). This plug will fit in a polarized outlet only one way. If the plug does not fit fully in the outlet, reverse the plug. If it still does not fit, contact a qualified electrician to install a polarized outlet. Do not change the plug in any way.** Double insulation eliminates the need for the three-wire grounded power cord and grounded power supply system.
- **Avoid body contact with grounded surfaces, such as pipes, radiators, ranges, and refrigerators.** There is an increased risk of electric shock if your body is grounded.
- **Don't expose power tools to rain or wet conditions.** Water entering a power tool will increase the risk of electric shock.
- **Do not abuse the cord. Never use the cord to carry the tools or pull the plug from an outlet.**

Keep cord away from heat, oil, sharp edges, or moving parts. Replace damaged cords immediately. Damaged cords increase the risk of electric shock.

- **When operating a power tool outside, use an outdoor extension cord marked "W-A" or "W".** These cords are rated for outdoor use and reduce the risk of electric shock.

Personal Safety

- **Stay alert, watch what you are doing and use common sense when operating a power tool. Do not use tool while tired or under the influence of drugs, alcohol, or medication.** A moment of inattention while operating power tools may result in serious personal injury.
- **Dress properly. Do not wear loose clothing or jewelry. Contain long hair. Keep your hair, clothing, and gloves away from moving parts.** Loose clothes, jewelry, or long hair can be caught in moving parts.
- **Avoid accidental starting. Be sure switch is off before plugging in.** Carrying tools with your finger on the switch or plugging in tools that have the switch on, invites accidents.
- **Remove adjusting keys or wrenches before turning the tool on.** A wrench or a key that is left attached to a rotating part of the tool may result in personal injury.
- **Do not overreach. Keep proper footing and balance at all times.** Proper footing and balance enables better control of the tool in unexpected situations.
- **Use safety equipment. Always wear eye protection.** Dust mask, nonskid safety shoes, hard hat, or hearing protection must be used for appropriate conditions.

GENERAL SAFETY RULES

Tool Use and Care

- **Use clamps or another practical way to secure and support the workpiece to a stable platform.** Holding the work by hand or against your body is unstable and may lead to loss of control.
- **Do not force tool. Use the correct tool for your application.** The correct tool will do the job better and safer at the rate for which it is designed.
- **Do not use tool if switch does not turn it on or off.** Any tool that cannot be controlled with the switch is dangerous and must be repaired.
- **Disconnect the plug from power source before making any adjustments, changing accessories, or storing the tool.** Such preventive safety measures reduce the risk of starting the tool accidentally.
- **Store idle tools out of the reach of children and other untrained persons.** Tools are dangerous in the hands of untrained users.
- **Maintain tools with care. Keep cutting tools sharp and clean.** Properly maintained tools with sharp cutting edges are less likely to bind and are easier to control.

- **Check for misalignment or binding of moving parts, breakage of parts, and any other condition that may affect the tool's operation. If damaged, have the tool serviced before using.** Many accidents are caused by poorly maintained tools.
- **Use only accessories that are recommended by the manufacturer for your model.** Accessories that may be suitable for one tool, may become hazardous when used on another tool.

Service

- **Tool service must be performed only by qualified repair personnel.** Service or maintenance performed by unqualified personnel could result in a risk of injury.
- **When servicing a tool, use only identical replacement parts. Follow instructions in the Maintenance section of this manual.** Use of unauthorized parts or failure to follow Maintenance Instructions may create a risk of electric shock or injury.

SPECIFIC SAFETY RULES

Specific Safety Rules for Circular Saws

- **DANGER! Keep hands away from cutting area and blade. Keep your second hand on the auxiliary handle or motor housing.** If both hands are holding the saw, they cannot be cut by the blade.
- **Keep your body positioned to either side of the saw blade, but not in line with the saw blade.** Kickback could cause the saw to jump backwards. (See "Causes and Operator Prevention of Kickback.")
- **Do not reach underneath the work.** The guard cannot protect you from the blade below the work.
- **Check lower guard for proper closing before each use. Do not operate saw if lower guard does not move freely and close instantly. Never clamp or tie the lower guard into the open position.** If saw

is accidentally dropped, lower guard may be bent. Raise the lower guard with the retracting handle. Make sure it moves freely and does not touch the blade or any other part, in all angles and depths of cut.

- **Check the operation and condition of the lower guard spring. If the guard and the spring are not operating properly, they must be serviced before use.** Lower guard may operate sluggishly due to damaged parts, gummy deposits, or a buildup of debris.
- **Lower guard should be retracted manually only for special cuts, such as "Pocket Cuts" and "Compound Cuts."** Raise lower guard by retracting handle. As soon as blade enters the material, lower guard must be released. For all other sawing, the lower guard should operate automatically.

SPECIFIC SAFETY RULES

Specific Safety Rules for Circular Saws (continued)

- **Always observe that the lower guard is covering the blade before placing saw down on bench or floor.** An unprotected, coasting blade will cause the saw to walk backwards, cutting whatever is in its path. Be aware of the time it takes for the blade to stop after switch is released.
- **NEVER hold piece being cut in your hands or across your leg.** It is important to support the work properly to minimize body exposure, blade binding, or loss of control.
- **Hold tool by insulated gripping surface when performing an operation where the cutting tool may contact hidden wiring or its own cord.** Contact with a "live" wire will also make exposed metal parts of the tool "live" and shock the operator.
- **When ripping, always use a rip fence or straight edge guide.** This improves the accuracy of the cut and reduces the chance for blade binding.
- **Always use blades with correct size and shape (diamond vs. round) arbor holes.** Blades that do not match the mounting hardware of the saw will run eccentrically, causing loss of control.
- **Never use damaged or incorrect blade washers or bolts.** The blade washers and bolts were specially designed for your saw for optimum performance and safety of operation.

Causes and Operator Prevention of Kickback

- Kickback is a sudden reaction to a pinched, bound, or misaligned saw blade, causing an uncontrolled saw to lift up and out of the workpiece toward the operator.
- When the blade is pinched or bound tightly by the kerf closing down, the blade stalls and the motor reaction drives the unit rapidly back toward the operator.
- If the blade becomes twisted or misaligned in the cut, the teeth at the back edge of the blade can dig into the top surface of the wood

causing the blade to climb out of the kerf and jump back toward the operator.

- Kickback is the result of tool misuse and/or incorrect operating procedures or conditions and can be avoided by taking proper precautions, as given below:
- **Maintain a firm grip with both hands on the saw and position your body and arm to allow you to resist KICKBACK forces.** KICKBACK forces can be controlled by the operator, if proper precautions are taken.
- **When blade is binding, or when interrupting a cut for any reason, release the trigger and hold the saw motionless in the material until the blade comes to a complete stop. Never attempt to remove the saw from the work or pull the saw backward while the blade is in motion, or KICKBACK may occur.** Investigate and take corrective actions to eliminate the cause of blade binding.
- **When restarting a saw in the workpiece, center the saw blade in the kerf and check that saw teeth are not engaged into the material.** If saw blade is binding, it may walk up or KICKBACK from the workpiece as the saw is restarted.
- **Support large panels to minimize the risk of blade pinching and KICKBACK.** Large panels tend to sag under their own weight. Supports must be placed under the panel on both sides, near the line of cut and near the edge of the panel.
- **Do not use dull or damaged blade.** Unsharpened or improperly set blades produce narrow kerf which causes excessive friction, blade binding and KICKBACK.
- **Blade depth and bevel adjusting locking levers must be tight and secure before making cut.** If blade adjustment shifts while cutting, it may cause binding and KICKBACK.
- **Use extra caution when making a "Pocket Cut" into existing walls or other blind areas.** The protruding blade may cut objects that can cause KICKBACK.

SPECIFIC SAFETY RULES AND/OR SYMBOLS

Hold tool by insulated gripping surfaces when performing an operation where the cutting tool may contact hidden wiring or its cord. Contact with a “live” wire will make exposed metal parts of the tool “live” and shock the operator.

Additional Rules For Safe Operation

- **Know your power tool.** Read operator’s manual carefully. Learn its applications and limitations, as well as the specific potential hazards related to this tool. Following this rule will reduce the risk of electric shock, fire, or serious injury.
- **Always wear safety glasses.** Everyday eye-glasses have only impact-resistant lenses; they are NOT safety glasses. Following this rule will reduce the risk of serious personal injury.
- **Protect your lungs.** Wear a face or dust mask if the operation is dusty. Following this rule will reduce the risk of serious personal injury.
- **Protect your hearing.** Wear hearing protection during extended periods of operation. Following this rule will reduce the risk of serious personal injury.
- **Inspect tool cords periodically and, if damaged, have repaired at your nearest Factory Service Center or other Authorized Service Organization.** Constantly stay aware of cord location. Following this rule will reduce the risk of electric shock or fire.
- **Check damaged parts.** Before further use of the tool, a guard or other part that is damaged should be carefully checked to determine that it will operate properly and perform its intended function. Check for alignment of moving parts, binding of moving parts, breakage of parts, mounting, and any other conditions that may affect its operation. A guard or other part that is damaged should be properly repaired or replaced by an authorized service center. Following this rule will reduce the risk of shock, fire, or serious injury.
- **Do not abuse cord.** Never carry the tool by the cord or yank it to disconnect it from the receptacle. Keep cord away from heat, oil, and sharp edges. Following this rule will reduce the risk of electric shock or fire.

- **Make sure your extension cord is in good condition.** When using an extension cord, be sure to use one heavy enough to carry the current your product will draw. A wire gage size (A.W.G.) of at least 16 is recommended for an extension cord 100 feet or less in length. A cord exceeding 100 feet is not recommended. If in doubt, use the next heavier gage. The smaller the gage number, the heavier the cord. An undersized cord will cause a drop in line voltage resulting in loss of power and overheating.
- **Inspect for and remove all nails from lumber before sawing.** Following this rule will reduce the risk of serious personal injury.
- **Drugs, alcohol, medication.** Do not operate tool while under the influence of drugs, alcohol, or any medication. Following this rule will reduce the risk of electric shock, fire, or serious personal injury.
- **Save these instructions.** Refer to them frequently and use them to instruct others who may use this tool. If you loan someone this tool, loan them these instructions also.

⚠ WARNING: Some dust created by power sanding, sawing, grinding, drilling, and other construction activities contains chemicals known to cause cancer, birth defects or other reproductive harm. Some examples of these chemicals are:

- lead from lead-based paints,
- crystalline silica from bricks and cement and other masonry products, and
- arsenic and chromium from chemically-treated lumber.



Your risk from these exposures varies, depending on how often you do this type of work. To reduce your exposure to these chemicals: work in a well ventilated area, and work with approved safety equipment, such as those dust masks that are specially designed to filter out microscopic particles.

⚠ WARNING:



The operation of any circular saw can result in foreign objects being thrown into your eyes, which can result in severe eye damage. Before beginning power tool operation, always wear safety goggles or safety glasses with side shields and a full face shield when needed. We recommend Wide Vision Safety Mask for use over eyeglasses or standard safety glasses with side shields, available at Sears Retail Stores.

SYMBOLS

SYMBOL	NAME	DESIGNATION/EXPLANATION
V	Volts	Voltage
A	Amperes	Current
Hz	Hertz	Frequency (cycles per second)
min	Minutes	Time
~	Alternating Current	Type or a characteristic of current
≡	Direct Current	Type or a characteristic of current
n_0	No Load Speed	Rotational speed, at no load
	Class II Construction	Designates Double Insulated Construction Tools
.../min	Revolutions or Reciprocation Per Minute	Revolutions, strokes, surface speed, orbits etc. per minute
	Safety Alert Symbol	Indicates danger, warning or caution. It means attention!!! Your safety is involved.

The purpose of safety symbols is to attract your attention to possible dangers. The safety symbols, and the explanations with them, deserve your careful attention and understanding. The safety warnings do not by themselves eliminate any danger. The instructions or warnings they give are not substitutes for proper accident prevention measures.

SYMBOL MEANING



SAFETY ALERT SYMBOL:

Indicates danger, warning, or caution. May be used in conjunction with other symbols or pictographs.



DANGER: Failure to obey a safety warning will result in serious injury to yourself or to others. Always follow the safety precautions to reduce the risk of fire, electric shock, and personal injury.



WARNING: Failure to obey a safety warning can result in serious injury to yourself or to others. Always follow the safety precautions to reduce the risk of fire, electric shock, and personal injury.



CAUTION: Failure to obey a safety warning may result in property damage or personal injury to yourself or to others. Always follow the safety precautions to reduce the risk of fire, electric shock, and personal injury.

NOTE: Advises you of information or instructions vital to the operation or maintenance of the equipment.

SAVE THESE INSTRUCTIONS

UNPACKING

Your circular saw has been shipped completely assembled except for the blade. Inspect it carefully to make sure no breakage or damage has occurred during shipping. If any parts are damaged or missing, contact your nearest Sears Retail Store to obtain replacement parts before attempting to operate saw. A blade, blade wrench, and this owner's manual are also included.

⚠ WARNING: If any parts are missing, do not operate this tool until the missing parts are replaced. Failure to do so could result in possible serious personal injury.

PRODUCT SPECIFICATIONS

Horsepower		Cutting Depth at 0° Bevel Cut	2-3/8 in. (60 mm)
Model 315.108400	2-1/3	Cutting Depth at 45° Bevel Cut	1-13/16 in. (46 mm)
Model 315.108410	2-1/2	Cutting Depth at 51.5° Bevel Cut	1-5/8 in. (41 mm)
Input		Rating	120 volts, 60 Hz, AC
Model 315.108400	11 Amperes	No Load Speed	
Model 315.108410	12 Amperes	Model 315.108400	4,700 RPM
Blade Diameter	7-1/4 in. (184 mm)	Model 315.108410	5,000 RPM
Blade Arbor	5/8 in. (16 mm)		

FEATURES

KNOW YOUR CIRCULAR SAW

See Figure 1.

Before attempting to use any tool, familiarize yourself with all operating features and safety requirements.

Your circular saw has many features for making cutting operations more pleasant and enjoyable. Safety, performance and dependability have been given top priority in the design of this saw making it easy to maintain and operate.

Features include easily operated bevel cut and depth of cut adjustment mechanisms, positive 0° bevel stop, length of cut scale, depth of cut scale, directed air flow for keeping line of cut clear, blade wrench storage, dust chute, and spindle lock button on Model 315.108410 only.

⚠ CAUTION: Carefully read through this entire owner's manual before using your new circular saw. Pay close attention to the Rules For Safe Operation, Warnings and Cautions. If you use your circular saw properly and only for what it is intended, you will enjoy years of safe, reliable service.

APPLICATIONS

(Use only for the purpose listed below)

- Cutting all types of wood products (lumber, plywood, paneling).

ELECTRICAL CONNECTION

Your circular saw has a precision built electric motor. It should be connected to a **power supply that is 120 volts, 60 Hz, AC only (normal household current)**. Do not operate this tool on direct current (DC). A substantial voltage drop will cause a loss of power and the motor will overheat. If your saw does not operate when plugged into an outlet, double-check the power supply.

SWITCH

To turn your saw **ON**, depress the switch trigger. Release switch trigger to turn your saw **OFF**.

DUST CHUTE

To direct saw dust and chips away from the operator, a dust chute is located on the side of the upper blade guard. An optional dust nozzle, that fits over the dust chute, is available at your nearest Sears Retail Store.

SPINDLE LOCK BUTTON – MODEL 315.108410

A spindle lock button has been provided for locking the spindle on your saw in a stationary position.

⚠ WARNING: Do not allow familiarity with your saw to make you careless. Remember that a careless fraction of a second is sufficient to inflict severe injury.

FEATURES

MODEL 315.108400 / MODEL 315.108410

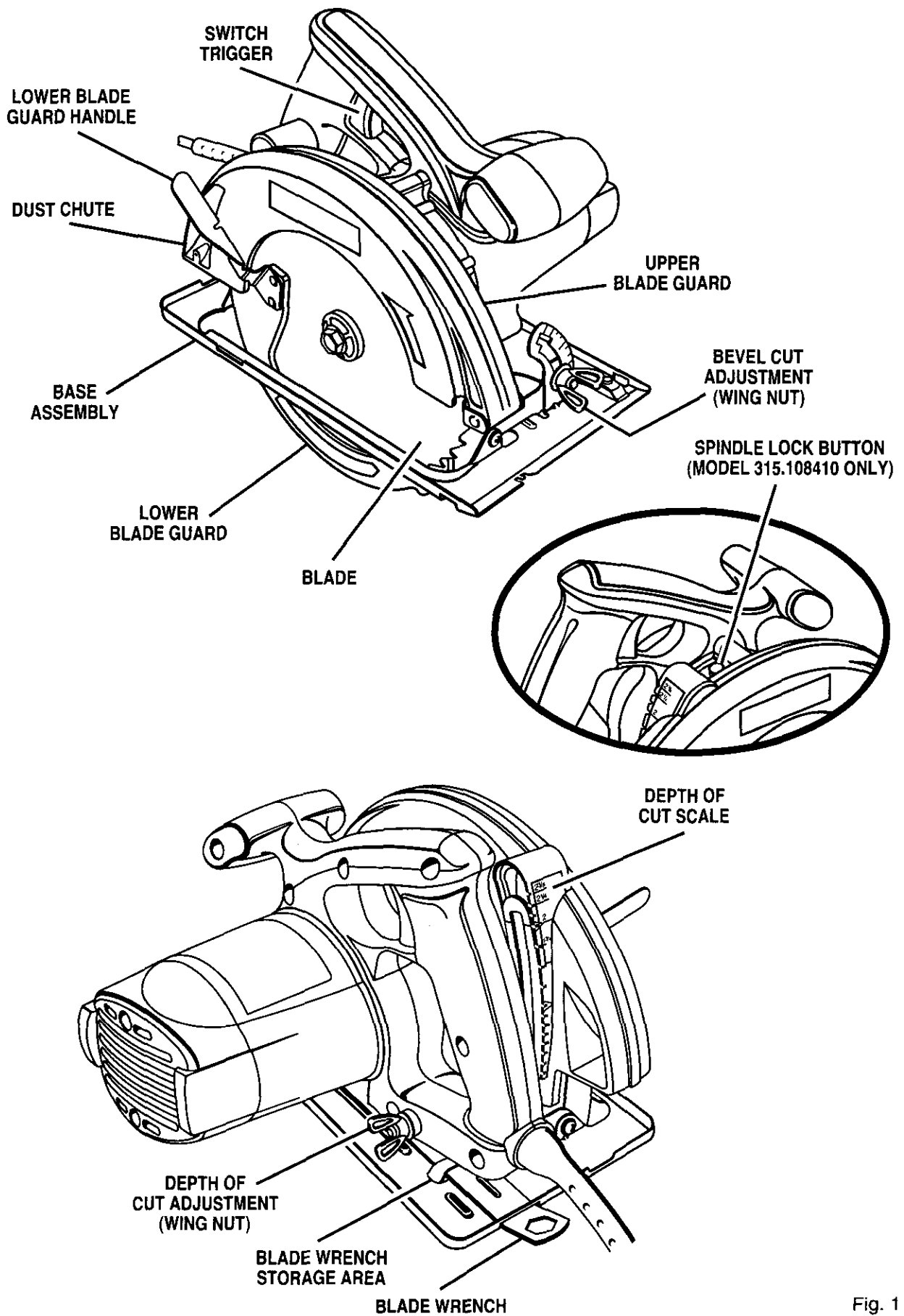

Fig. 1

ASSEMBLY

⚠ WARNING: Your saw should never be connected to power supply when you are assembling parts, making adjustments, assembling or removing blades, cleaning, or when not in use. Disconnecting your saw will prevent accidental starting that could cause serious personal injury.

⚠ WARNING: A 7-1/4 in. blade is the maximum blade capacity of your saw. Never use a blade that is too thick to allow outer blade washer to engage with the flat on the spindle. Larger blades will come in contact with the blade guards, while thicker blades will prevent blade screw from securing blade on spindle. Either of these situations could result in a serious accident.

TO ASSEMBLE OR REMOVE BLADE MODEL 315.108400

See Figures 2, 3, and 4.

■ Unplug your saw.

⚠ WARNING: Failure to unplug your saw could result in accidental starting causing possible serious personal injury.

TO ASSEMBLE BLADE:

■ Remove blade wrench from storage area.
See Figure 1.

■ Place your saw on a piece of wood as shown in Figure 4, and remove blade screw. See Figure 2.

Note: Turn blade screw counterclockwise to remove.

■ Remove spring washer, and outer blade washer ("D" washer). See Figure 2.

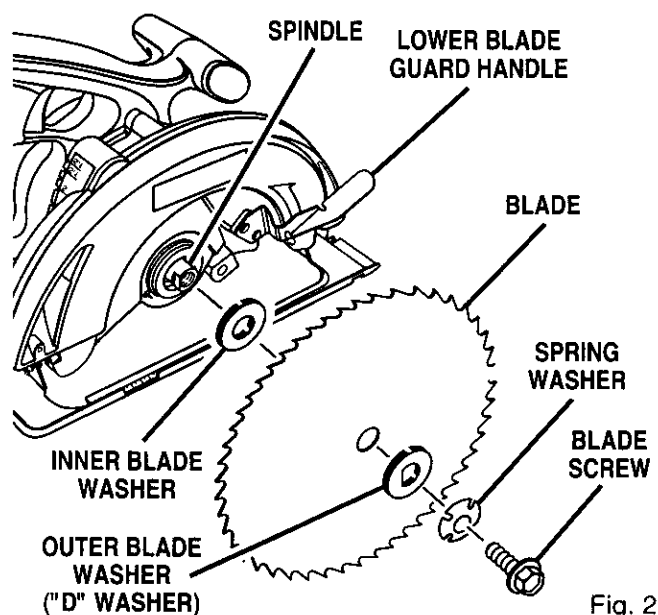

Fig. 2

■ Wipe a drop of oil onto inner blade washer and outer blade washer ("D" washer) where they contact blade.

⚠ WARNING: If inner blade washer has been removed, replace it before placing blade on spindle. Failure to do so could cause an accident since blade will not tighten properly.

■ Fit saw blade inside lower blade guard and onto spindle. **Note:** The saw teeth point upward at the front of saw as shown in Figure 2.

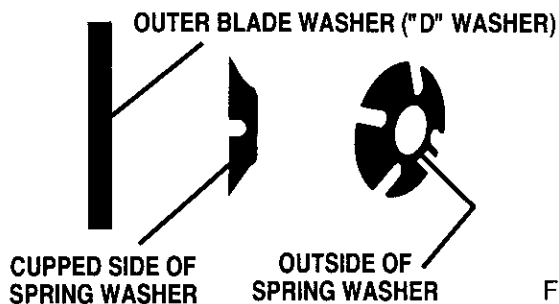

Fig. 3

■ Replace "D" washer and spring washer. **Note:** "Cupped" side of spring washer goes against "D" washer. See Figure 3.

■ Replace blade screw. Tighten blade screw securely. **Note:** Turn blade screw clockwise to tighten.

■ Return blade wrench to storage area. **Note:** Always place angled portion of blade wrench up as shown in Figure 1.

REMEMBER: Never use a blade that is too thick to allow the "D" washer to engage with the flat on the spindle.

TO REMOVE BLADE:

■ Remove blade wrench from storage area.
See Figure 1.

■ Place your saw on a piece of scrap wood as shown in Figure 4, and remove blade screw. See Figure 2. **Note:** With blade teeth embedded in the wood, turn blade screw counterclockwise to remove.

■ Remove spring washer and outer blade washer ("D" washer). See Figure 2.

Note: Blade can be removed at this point.

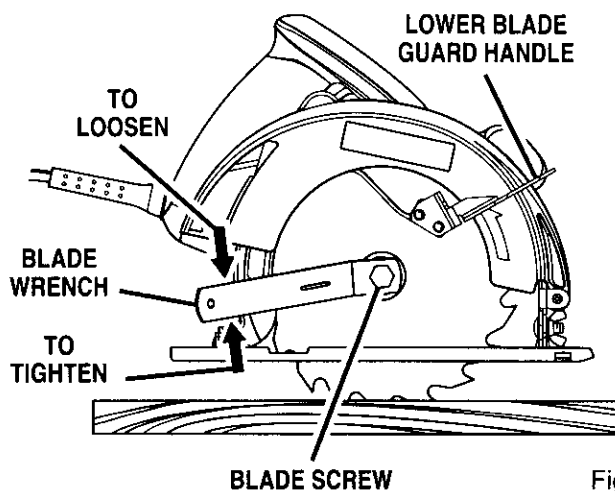

Fig. 4

ASSEMBLY

TO ASSEMBLE OR REMOVE BLADE

MODEL 315.1084100

See Figures 5, 6, and 7.

- Unplug your saw.

⚠ WARNING: Failure to unplug your saw could result in accidental starting causing possible serious personal injury.

SPINDLE LOCK BUTTON - MODEL 315.108410

If your saw is model 315.108410 it has a spindle lock button for locking the spindle on your saw in a stationary position. Depress and hold the spindle lock button while installing, changing or removing the blade.

TO ASSEMBLE BLADE:

- Remove blade wrench from storage area. See Figure 1.
- Position your saw as shown in Figure 7, depress spindle lock button, and remove blade screw. See Figure 5.
- Note:** Turn blade screw counterclockwise to remove.
- Remove spring washer, and outer blade washer ("D" washer). See Figure 5.

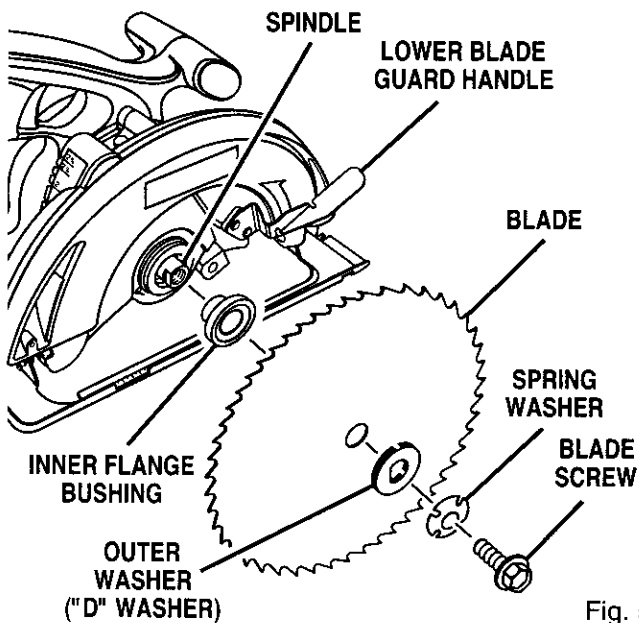

Fig. 5

- Wipe a drop of oil onto inner flange bushing and outer blade washer ("D" washer) where they contact blade.

⚠ WARNING: If inner flange bushing has been removed, replace it before placing blade on spindle. Failure to do so could cause an accident since blade will not tighten properly.

- Fit saw blade inside lower blade guard and onto spindle. **Note:** The saw teeth point upward at the front of saw as shown in Figure 5.

- Replace "D" washer and spring washer. **Note:** "Cupped" side of spring washer goes against "D" washer. See Figure 6.

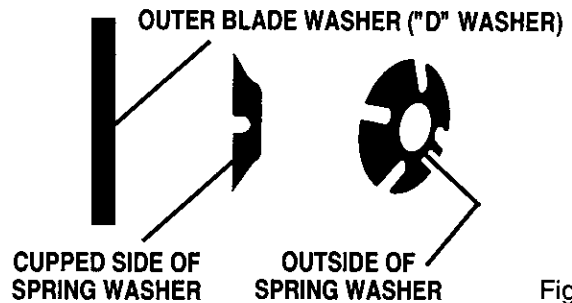

Fig. 6

- Depress spindle lock button, then replace blade screw. Tighten blade screw securely. **Note:** Turn blade screw clockwise to tighten.
- Return blade wrench to storage area. **Note:** Always place angled portion of blade wrench up as shown in Figure 1.

REMEMBER: Never use a blade that is too thick to allow the "D" washer to engage with the flat on the spindle.

TO REMOVE BLADE:

- Remove blade wrench from storage area. See Figure 1.
- Position your saw as shown in Figure 7, depress spindle lock button, and remove blade screw. **Note:** Turn blade screw counterclockwise to remove.
- Remove spring washer and outer blade washer ("D" washer). See Figure 5.

Note: Blade can be removed at this point.

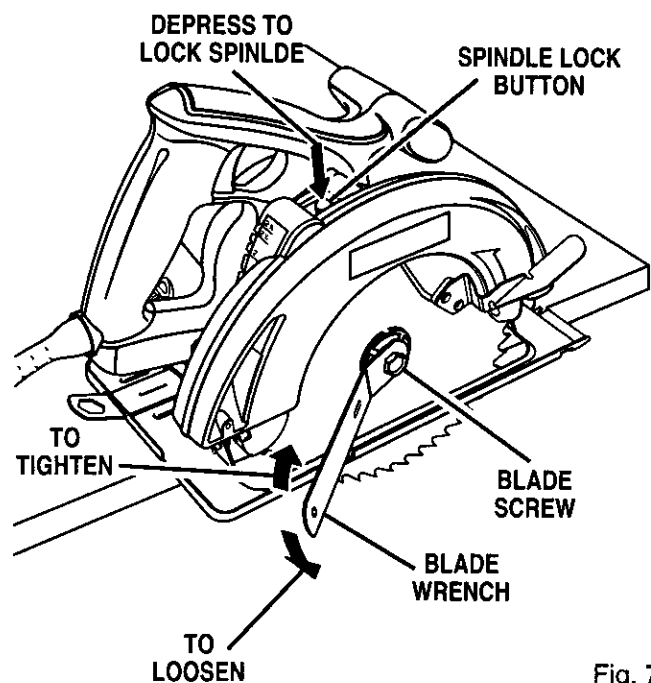

Fig. 7

OPERATION

SAW BLADES

The best of saw blades will not cut efficiently if they are not kept clean, sharp, and properly set. Using a dull blade will place a heavy load on your saw and increase the danger of kickback. Keep extra blades on hand, so that sharp blades are always available.

Gum and wood pitch hardened on blades will slow your saw down. Use gum and pitch remover, hot water, or kerosene to remove these accumulations. **Do not use gasoline.**

BLADE GUARD SYSTEM

The lower blade guard attached to your circular saw is there for your protection and safety. It should never be altered for any reason. If it becomes damaged or begins to return slow or sluggish, do not operate your saw until the damage has been repaired or replaced. Always leave guard in operating position when using saw.

⚠ DANGER: When sawing through workpiece, lower blade guard does not cover blade on the underside of workpiece. Since blade is exposed on underside of workpiece, keep hands and fingers away from cutting area. Any part of your body coming in contact with moving blade will result in serious injury. See Figure 8.

LOWER BLADE GUARD IS IN UP POSITION WHEN MAKING A CUT

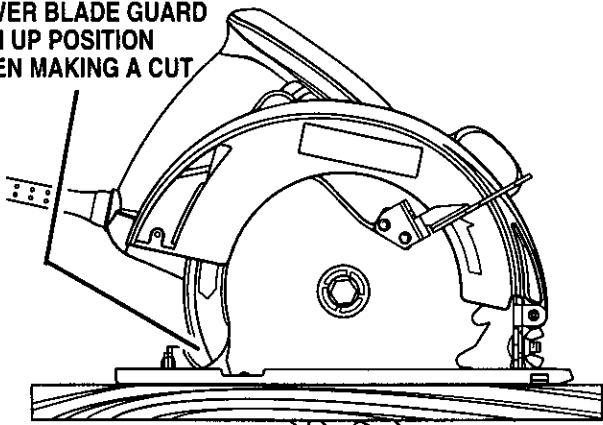

BLADE EXPOSED ON UNDERSIDE OF WORKPIECE

Fig. 8

⚠ CAUTION: Never use saw when guard is not operating correctly. Guard should be checked for correct operation before each use. If you drop your saw, check the lower blade guard and bumper for damage at all depth settings before reuse. **Note:** The guard is operating correctly when it moves freely and readily returns to the closed position. If for any reason your lower blade guard does not close freely, take it to the nearest Sears Repair Center for service before using.

KICKBACK

See Figure 9.

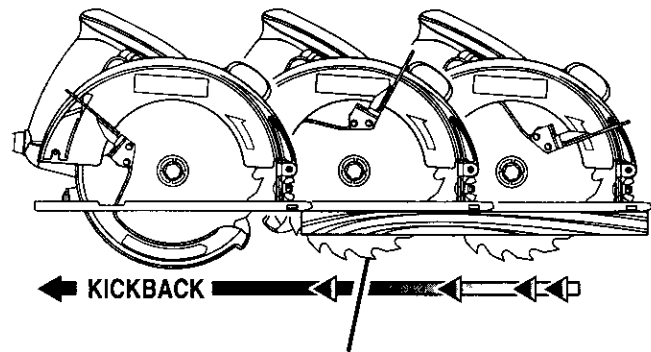

BLADE SET TOO DEEP

Fig. 9

The best guard against kickback is to avoid dangerous practices.

Kickback occurs when the blade stalls rapidly and the saw is driven back towards you. Blade stalling is caused by any action which pinches the blade in the wood.

⚠ DANGER: Release switch immediately if blade binds or saw stalls. Kickback could cause you to lose control of your saw. Loss of control can lead to serious injury.

KICKBACK IS CAUSED BY:

- Incorrect blade depth setting. See Figure 9.
- Sawing into knots or nails in workpiece.
- Twisting blade while making a cut.
- Making a cut with a dull, gummed up, or improperly set blade.
- Incorrectly supporting workpiece. See Figure 10.

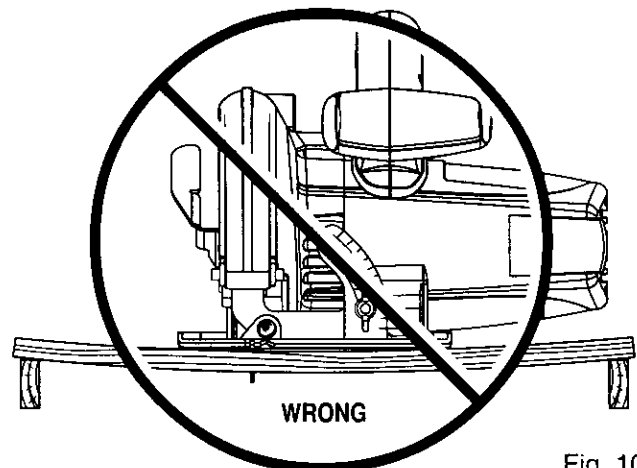

WRONG

Fig. 10

- Forcing a cut.
- Cutting warped or wet lumber.
- Tool misuse or incorrect operating procedures.

OPERATION

TO LESSEN THE CHANCE OF KICKBACK:

- Always keep the correct blade depth setting – the correct blade depth setting for all cuts should not exceed 1/4 inch below the material to be cut. See Figure 11.

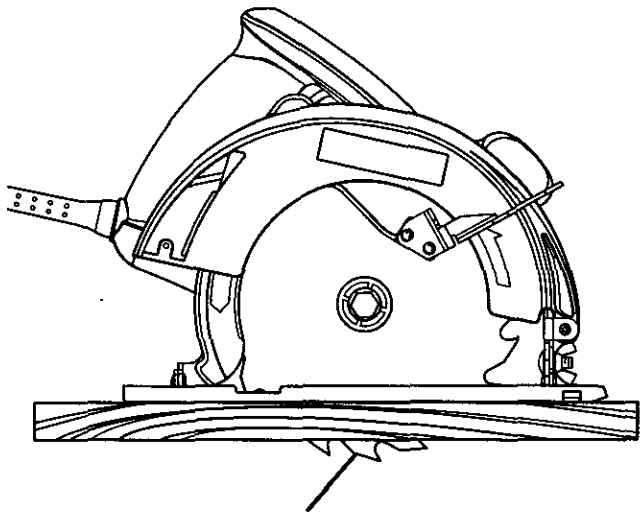

**CORRECT BLADE DEPTH SETTING = BLADE EXPOSED
1/4 in. OR LESS ON UNDERSIDE OF WORKPIECE**

Fig. 11

- Inspect the workpiece for knots or nails before beginning a cut. Never saw into a knot or nail.
- Make straight cuts. Always use a straight edge guide when rip cutting. This helps prevent twisting the blade in the cut.
- Always use clean, sharp and properly set blades. Never make cuts with dull blades.
- To avoid pinching the blade, support the workpiece properly before beginning a cut. The right and wrong ways to support large pieces of work are shown in Figures 10 and 12.

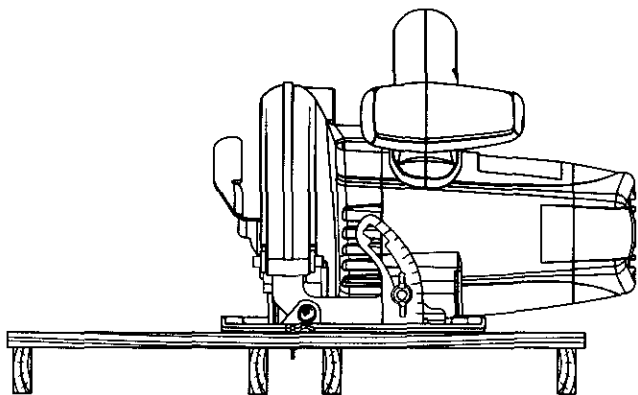

RIGHT

Fig. 12

- When making a cut use steady, even pressure. Never force cuts.
- Do not cut warped or wet lumber.
- Always hold your saw firmly with both hands and keep your body in a balanced position so as to resist the forces of kickback should it occur.

When using your saw, always stay alert and exercise control. Do not remove your saw from workpiece while the blade is moving.

DEPTH OF CUT ADJUSTMENT

See Figure 13.

Always keep correct blade depth setting. The correct blade depth setting for all cuts should not exceed 1/4 inch below the material to be cut. More blade depth will increase the chance of kickback and cause the cut to be rough. For more depth of cut accuracy, a scale is located on the upper blade guard.

TO ADJUST BLADE DEPTH

- Unplug your saw.

WARNING: Failure to unplug your saw could result in accidental starting causing possible serious personal injury.

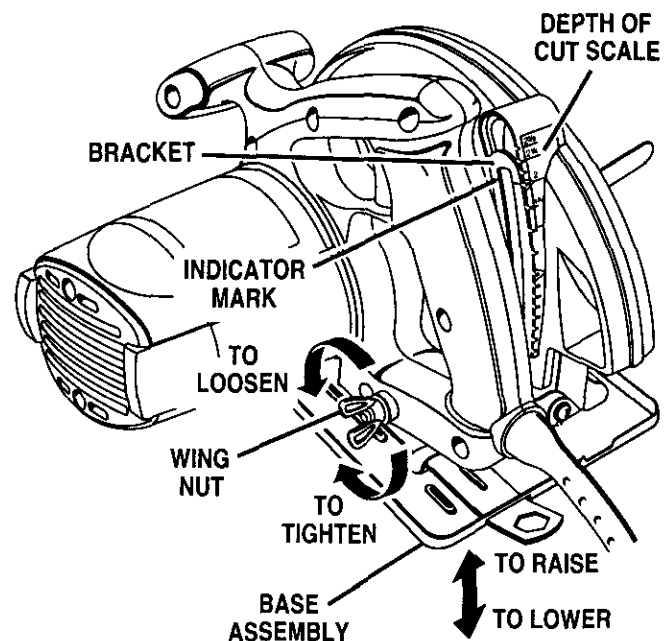

Fig. 13

- Loosen wing nut. See Figure 13.
- Determine the desired depth of cut.
- Locate depth of cut scale on back of upper blade guard.
- Hold base flat against the workpiece and raise or lower saw until the indicator mark on bracket aligns with notch on blade guard.
- Tighten wing nut securely.

OPERATION

STARTING A CUT

Know the right way to use your saw.
See Figure 14.

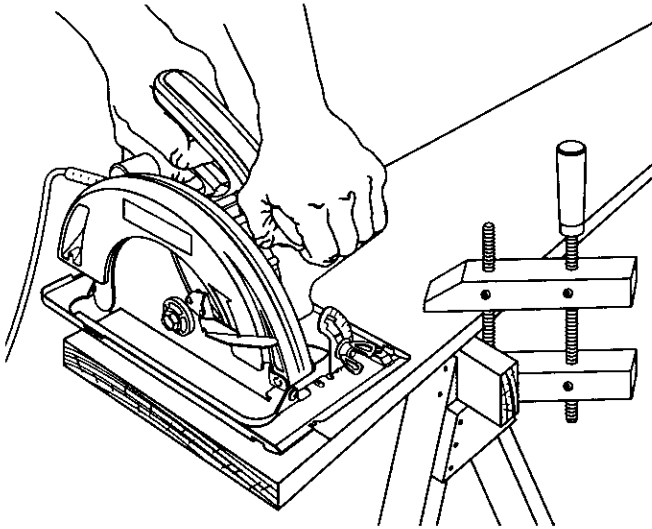

RIGHT

Fig. 14

⚠ WARNING: To make sawing easier and safer, always maintain proper control of your saw. Loss of control of your saw could cause an accident resulting in possible serious injury.

Never use your saw as shown in Figure 15.

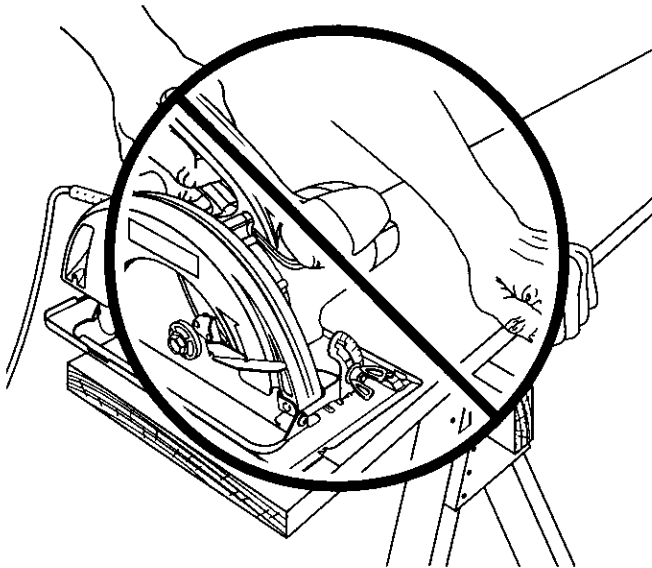

WRONG

Fig. 15

Never place your hand on the workpiece behind your saw while making a cut.

TO HELP MAINTAIN CONTROL:

- Always support your workpiece near the cut.
- Support your workpiece so the cut will be on your right.
- Clamp your workpiece so it will not move during the cut.

Place your workpiece with its good side down. **Note:** The good side is the side on which appearance is important.

Before beginning a cut, draw a guideline along the desired line of cut. Then place front edge of base on that part of your workpiece that is solidly supported. See Figure 14.

Never place your hand on that part of the workpiece that will fall off when the cut is made. See Figure 16.

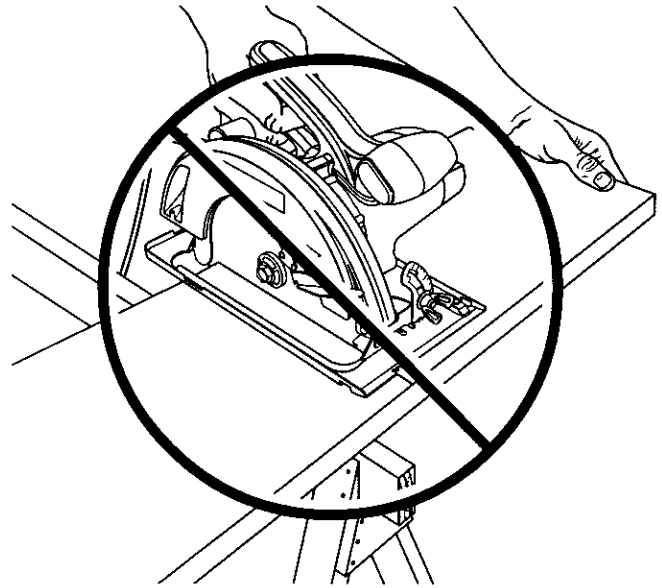

WRONG

Fig. 16

Keep the cord away from cutting area. **Always** place the cord to prevent it from hanging up on the workpiece while making a cut.

⚠ DANGER: If the cord hangs up on the workpiece during a cut, release the switch trigger immediately. Unplug your saw and reposition the cord to prevent it from hanging up again.

⚠ DANGER: Using your saw with a damaged cord could result in serious injury or death. If the cord has been damaged, have it replaced before using your saw again.

OPERATION

Hold your saw firmly with both hands.
See Figure 17.

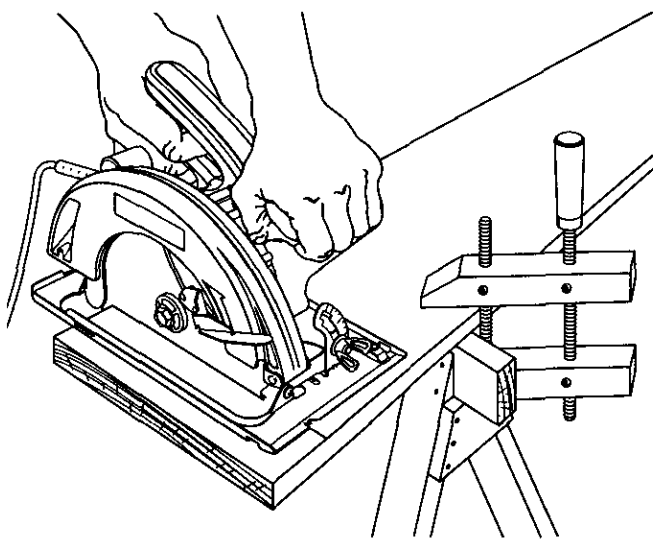

RIGHT

Fig. 17

Squeeze the switch trigger to start your saw. **Always** let the blade reach full speed, then guide your saw into the workpiece.

WARNING: The blade coming in contact with the workpiece before it reaches full speed could cause your saw to "kickback" towards you resulting in serious injury.

When making a cut use steady, even pressure. Forcing causes rough cuts, could shorten the life of your saw and could cause "kickback."

REMEMBER:

When sawing through work, the lower blade guard does not cover the blade, exposing it on the underside of work. Keep your hands and fingers away from cutting area. Any part of your body coming in contact with the moving blade will result in serious injury.

After you complete your cut release the trigger and allow the blade to come to a complete stop. **Do not remove your saw from workpiece while the blade is moving.**

CAUTION: When lifting your saw from the workpiece, the blade is exposed on the underside of your saw until the lower blade guard closes. Make sure lower guard is closed before setting your saw down on work surface.

TO CROSS CUT OR RIP CUT

When making a cross cut or rip cut, align your line of cut with the outer blade guide notch on the saw base as shown in Figure 18.

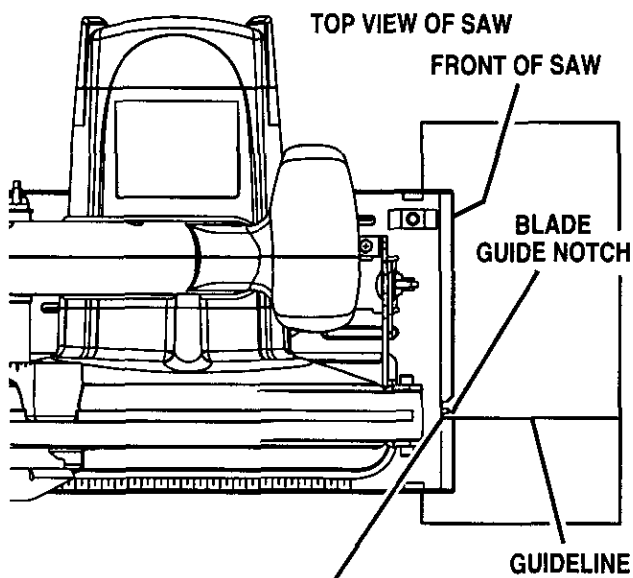

ALIGN OUTER BLADE GUIDE NOTCH ON SAW BASE WITH LINE OF CUT AS SHOWN WHEN MAKING CROSS CUTS OR RIP CUTS

Fig. 18

Since blade thicknesses vary, always make a trial cut in scrap material along a guideline to determine how much, if any, the guideline must be offset to produce an accurate cut. **Note:** The distance from the line of cut to the guideline is the amount you should offset the guideline.

OPERATION

TO BEVEL CUT

The angle of cut of your saw may be adjusted to any desired setting between zero and 51.5°. **Note:** When making cuts at 51.5° blade should be set at full depth of cut, with edge guide screw removed.

When making 45° bevel cuts, there is a notch in the saw base to help you line up the blade with the line of cut. See Figure 19.

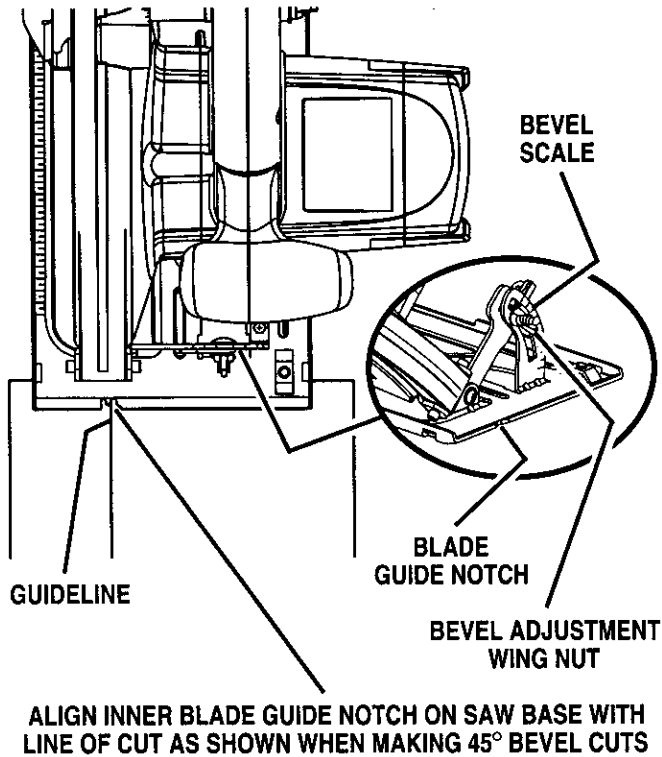

Fig. 19

Align your line of cut with the inner blade guide notch on the saw base when making 45° bevel cuts.

Since blade thicknesses vary and different angles require different settings, always make a trial cut in scrap material along a guideline to determine how much you should offset the guideline on the board to be cut.

When making a bevel cut hold your saw firmly with both hands as shown in Figure 20.

Rest the front edge of the base on the workpiece. Squeeze the switch trigger to start your saw. **Always** let the blade reach full speed, then guide your saw into the workpiece.

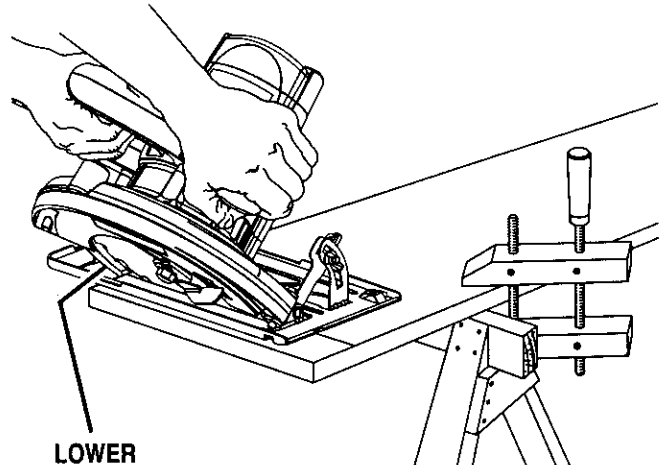

Fig. 20

WARNING: The blade coming in contact with the workpiece before it reaches full speed could cause saw to "kickback" toward you resulting in serious injury.

After you complete your cut release the trigger and allow the blade to come to a complete stop. **After** the blade has stopped, lift your saw from the workpiece.

TO ADJUST BEVEL SETTING

■ Unplug your saw.

WARNING: Failure to unplug your saw could result in accidental starting causing possible serious personal injury.

■ Loosen wing nut. See Figure 19.

■ Raise motor housing end of saw until you reach desired angle setting on bevel scale. See Figure 19.

■ Tighten wing nut securely.

WARNING: Attempting bevel cut without wing nut securely tightened can result in serious injury.

OPERATION

POSITIVE 0° BEVEL STOP

See Figure 21.

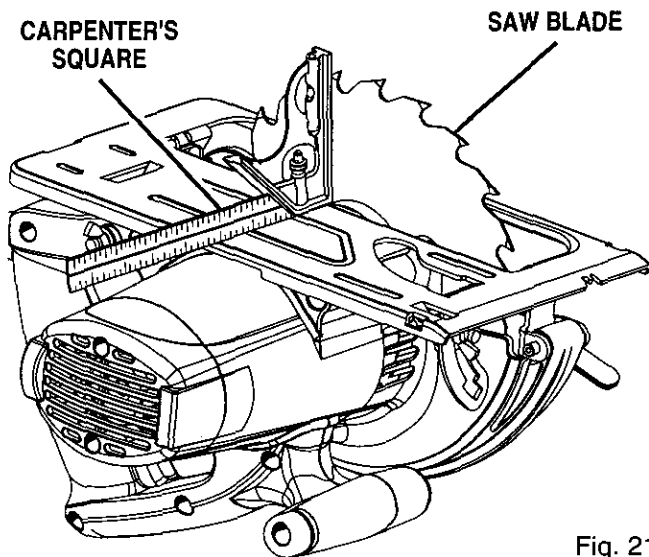
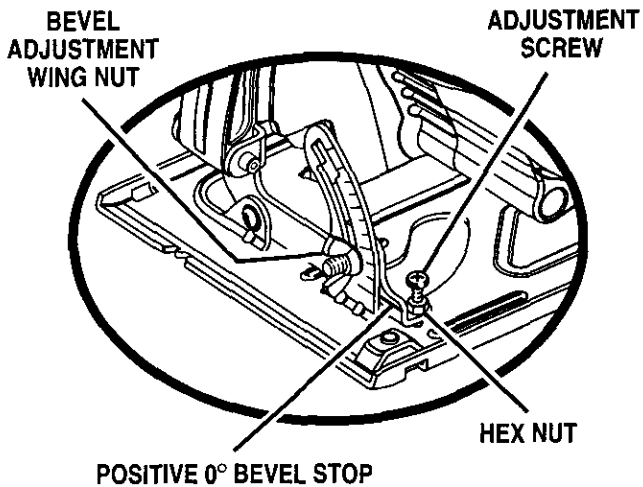

Fig. 21

Your saw has a positive 0° bevel stop, that has been factory adjusted to assure 0° angle of your saw blade when making 90° cuts. However, misalignment can occur during shipping.

TO CHECK

- Unplug your saw.

⚠ WARNING: Failure to unplug your saw could result in accidental starting causing possible serious personal injury.

- Place your saw in an upside down position on workbench. See Figure 21.
- Using a carpenter's square, check squareness of saw blade to the base of your saw.

TO ADJUST

- Unplug your saw.

⚠ WARNING: Failure to unplug your saw could result in accidental starting causing possible serious personal injury.

- Loosen wing nut.
- Loosen hex nut securing adjustment screw.
- Turn screw and adjust base until square with saw blade.
- Tighten hex nut and wing nut securely.

⚠ WARNING: Attempting to make cuts without wing nut securely tightened can result in serious injury.

LENGTH OF CUT SCALE

See Figure 22.

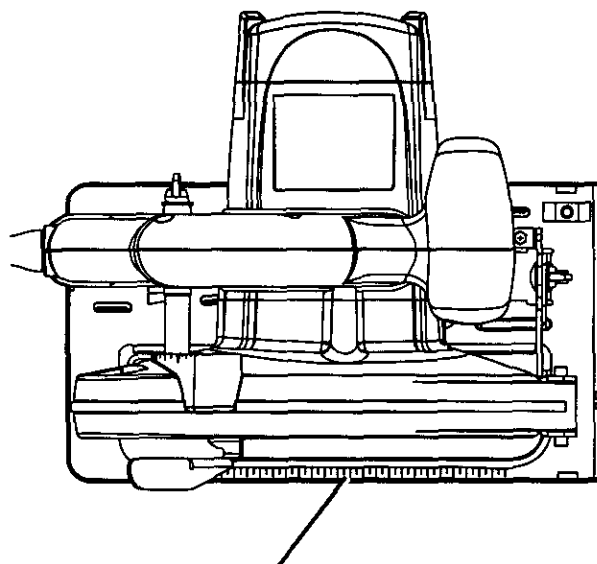

LENGTH OF CUT SCALE

Fig. 22

A length of cut scale has been provided on the base of your saw. It is parallel with the saw blade and can be used to measure the distance into material the blade has cut. **Note:** Six inches is the maximum length of cut that can be measured. Also, it is accurate only when the depth of cut is set at full maximum depth.

OPERATION

TO POCKET CUT

See Figure 23.

WARNING: Always adjust bevel setting to zero before making a pocket cut. Attempting a pocket cut at any other setting can result in loss of control of your saw possibly causing serious injury.

Adjust the bevel setting to zero, set blade to correct blade depth setting, and swing the lower blade guard up using the lower blade guard handle.

Always raise the lower blade guard with the handle to avoid serious injury.

While holding lower blade guard by the handle, firmly rest the front of the base flat against the workpiece with the rear of the handle raised so the blade does not touch the workpiece. See Figure 23.

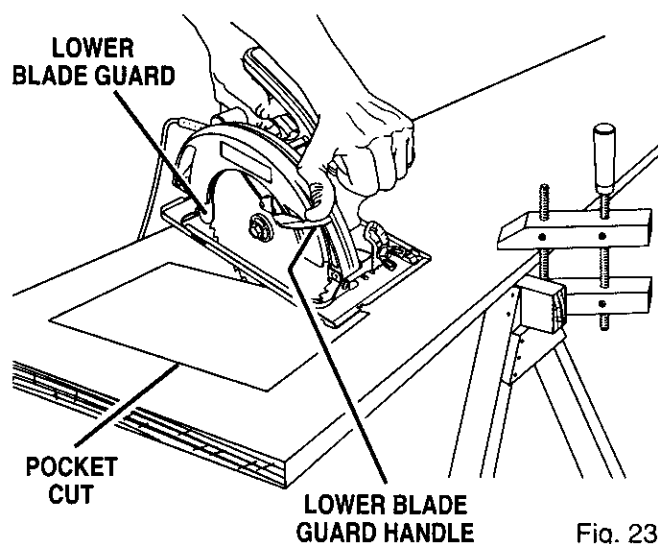

Fig. 23

Squeeze the switch trigger to start your saw. **Always let the blade reach full speed then slowly lower blade into the workpiece until base is flat against workpiece.**

After you complete your cut release the trigger and allow the blade to come to a complete stop. After the blade has stopped, remove it from the workpiece. Corners may then be cleared out with a hand saw or sabre saw.

WARNING: Never tie the lower blade guard in a raised position. Leaving the blade exposed could lead to serious injury.

TO RIP CUT

OPTIONAL RIP GUIDE (EDGE GUIDE)

See Figure 24.

Use a guide when making long or wide rip cuts with your saw. An optional rip guide with a five inch scale is available at your Sears Retail Store or you can make an efficient rip guide by clamping a straight edge to your workpiece. Secure the workpiece. Using

C-clamps, firmly clamp a straight edge to the workpiece and guide the saw along the straight edge to achieve a straight rip cut. Do not bind the blade in the cut. If using the optional rip guide, see the following instructions and Figure 25.

ALTERNATE METHOD FOR RIP CUTTING

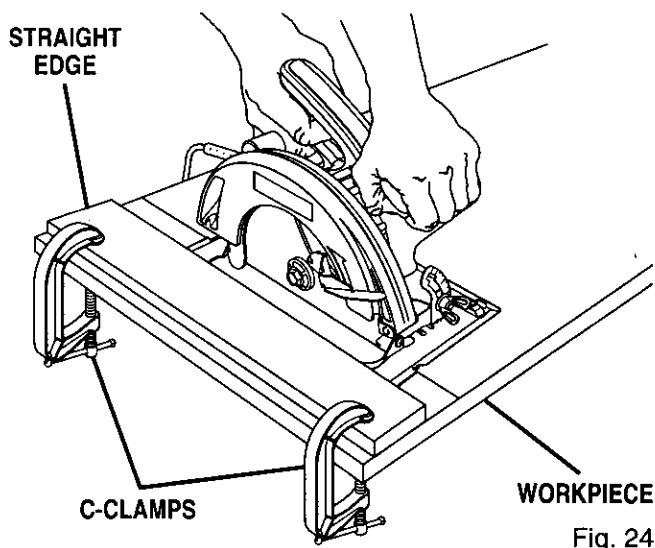

Fig. 24

TO ASSEMBLE OPTIONAL RIP GUIDE

■ Unplug your saw.

WARNING: Failure to unplug your saw could result in accidental starting causing possible serious personal injury.

■ Place rip guide through holes in saw base as shown in Figure 25.

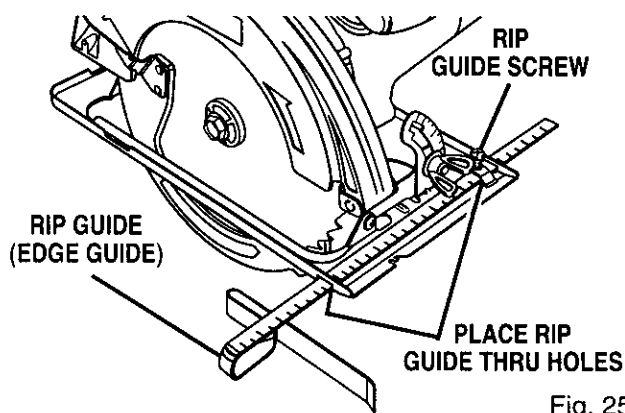

Fig. 25

■ Adjust rip guide to the width needed.

■ Tighten rip guide screw securely.

When using a rip guide, position the face of the rip guide firmly against the edge of workpiece. This makes for a true cut without pinching the blade. The guiding edge of workpiece must be straight for your cut to be straight. Use caution to prevent the blade from binding in the cut.

OPERATION

OPTIONAL DUST NOZZLE KIT

See Figure 26.

An optional dust nozzle kit, part no. 982829-001, is available for purchase at your nearest Sears Retail Store. As shown in Figure 26, the adapter fits over the dust chute which is located on the upper blade guard. The nozzle attaches to the adapter.

Note: If you use the nozzle, you should always connect it to a standard vacuum hose.

TO ATTACH DUST NOZZLE KIT

- Unplug your saw.

⚠ WARNING: Failure to unplug your saw could result in accidental starting causing possible serious personal injury.

- Orient adapter to fit into the dust chute opening (1) on upper blade guard. Secure adapter with screw (2) provided.
- When using a vacuum hose, align hole in nozzle with raised lip on adapter and snap into place (3).

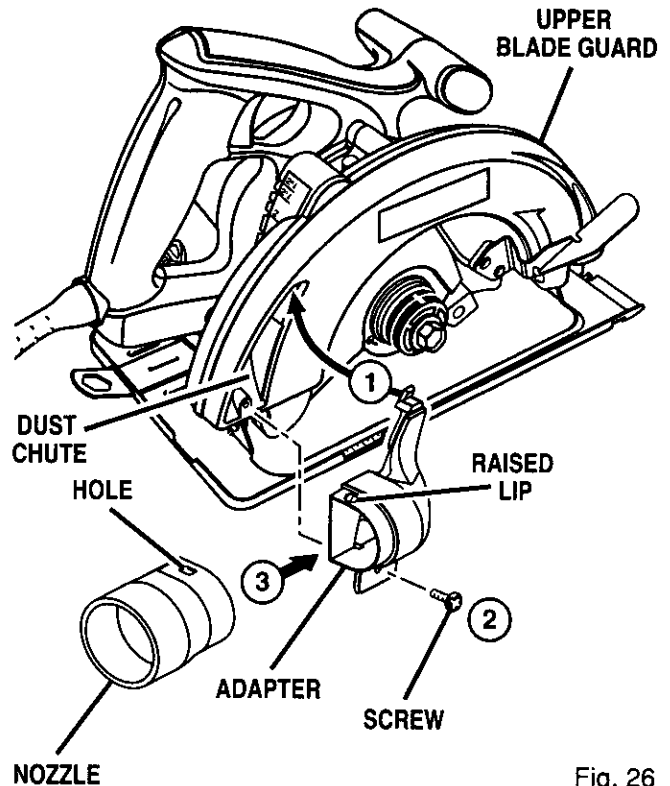

Fig. 26

MAINTENANCE

GENERAL

Only the parts shown on parts list, page 21, are intended to be repaired or replaced by the customer. All other parts represent an important part of the double insulation system and should be serviced only at a Sears Service Center.

Avoid using solvents when cleaning plastic parts. Most plastics are susceptible to damage from various types of commercial solvents and may be damaged by their use. Use clean cloths to remove dirt, carbon dust, etc.

⚠ WARNING: Do not at any time let brake fluids, gasoline, petroleum-based products, penetrating oils, etc. come in contact with plastic parts. They contain chemicals that can damage, weaken or destroy plastic.

It has been found that electric tools are subject to accelerated wear and possible premature failure when they are used on fiberglass boats, sports cars, wallboard, spackling compounds, or plaster. The chips and grindings from these materials are highly abrasive to electric tool parts, such as bearings, brushes, commutators, etc. Consequently, it is not recommended that this tool be used for extended work on any fiberglass material, wallboard, spackling compounds, or plaster. During any use on these materials, it is extremely important that the tool is cleaned frequently by blowing with an air jet.

LUBRICATION

All of the bearings in this tool are lubricated with a sufficient amount of high-grade lubricant for the life of the unit under normal operating conditions. Therefore, no further lubrication is required.

⚠ WARNING: Always wear safety goggles or safety glasses with side shields during power tool operation or when blowing dust. If operation is dusty, also wear a dust mask.

MAINTENANCE

DOUBLE INSULATION

Double insulation is a concept in safety in electric power tools, which eliminates the need for the usual three-wire grounded power cord. All exposed metal parts are isolated from the internal metal motor components with protecting insulation. Double insulated tools do not need to be grounded.

IMPORTANT

Servicing of a tool with double insulation requires extreme care and knowledge of the system and should be performed only by a qualified service technician. For service, we suggest you return the tool to your nearest Sears Service Center for repair. Always use original factory replacement parts when servicing.

EXTENSION CORDS

The use of any extension cord will cause some loss of power. To keep the loss to a minimum and to prevent tool overheating, use an extension cord that is heavy enough to carry the current the tool will draw.

A wire gage size (A.W.G.) of at least **16** is recommended for an extension cord 100 feet or less in length. When working outdoors, use an extension cord that is suitable for outdoor use. The cord's jacket will be marked **WA**.

 **CAUTION:** Keep extension cords away from the cutting area and position the cord so that it will not get caught on lumber, tools, etc., during cutting operation.

 **WARNING:** Check extension cords before each use. If damaged replace immediately. Never use tool with a damaged cord since touching the damaged area could cause electrical shock resulting in serious injury.

Extension cords suitable for use with your saw are available at your nearest Sears Retail Store.

ACCESSORIES

The following recommended accessories are currently available at Sears Retail Stores.

- 7-1/4 in. 40 Tooth General Purpose Cut-Off Blade
- 7-1/4 in. 35 Tooth Master Combination Blade
- 7-1/4 in. 200 Tooth Plywood Blade
- 7-1/4 in. 18 Tooth Carbide Blade
- 7-1/4 in. 18 Tooth Mach II Silver Series Carbide Blade
- 7-1/4 in. 24 Tooth Mach II Silver Series Carbide Blade
- 7-1/4 in. 24 Tooth Combination Carbide Blade
- Rip Guide
- Dust Nozzle Kit – Part No. 982829-001

 **WARNING:** The use of attachments or accessories not listed might be hazardous.

WARRANTY

FULL ONE YEAR WARRANTY ON CRAFTSMAN CIRCULAR SAW

If this **CRAFTSMAN** Circular Saw fails to give complete satisfaction within one year from the date of purchase, **RETURN IT TO THE NEAREST SEARS STORE OR SEARS SERVICE CENTER IN THE UNITED STATES**, and Sears will replace it, free of charge.

If this **CRAFTSMAN** Circular Saw is used for commercial or rental purposes, this warranty applies for only 90 days from the date of purchase.

This warranty gives you specific legal rights, and you may also have other rights which vary from state to state.

Sears, Roebuck and Co., Dept. 817WA, Hoffman Estates, IL 60179

CRAFTSMAN CIRCULAR SAW – MODEL NUMBER 315.108400

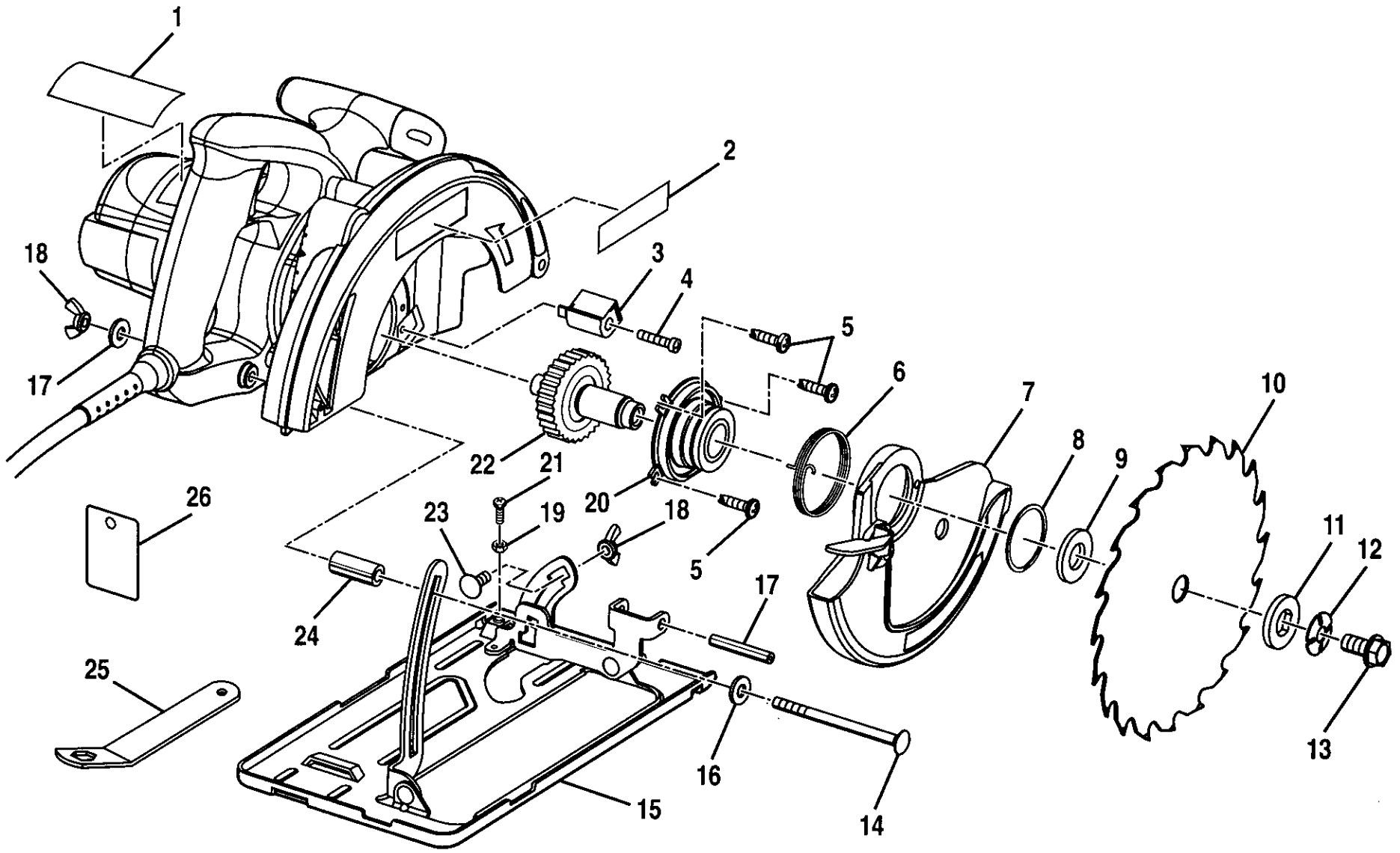

The model number will be found on a plate attached to the motor housing. Always mention the model number in all correspondence regarding your **CIRCULAR SAW** or when ordering repair parts.

SEE BACK PAGE FOR PARTS ORDERING INSTRUCTIONS

PARTS LIST

Key No.	Part Number	Description	Quan.	Key No.	Part Number	Description	Quan.
1	982595-001	Data Plate	1	15	3053002	Base Assembly	1
2	982820-001	Logo Plate	1	16	931744-059	Flat Washer	2
3	974900-001	Bumper	1	17	941401-310	Roll Pin	1
4	982492-131	* Screw (#8-32 x 3/4 in. Fil. Hd.)	1	18	621438-006	Wing Nut **STD541625	2
5	610122-003	* Screw (#8-32 x 3/8 in. Pan Hd.)	3	19	706404-007	Hex Nut (#8-32) **STD541008	1
6	967952-001	Torsion Spring	1	20	6447801	Lower Blade Guard Support	1
7	982380-001	Lower Blade Guard Assembly	1	21	614658-010	* Screw (#8-32 x 5/8 in. Pan Hd.)	1
8	718602-804	Retaining Ring	1	22	982481-001	Gear and Spindle Assembly	1
9	999982-001	Inner Blade Washer	1	23	621433-001	Carriage Bolt (1/4-20 x 5/8 in.) **STD532507	1
10	***	Saw Blade 7-1/4 in. for 5/8 in. Arbor	1	24	5542301	Spacer	1
11	998463-001	Outer Blade Washer	1	25	974716-001	Wrench	1
12	623547-002	Spring Washer	1	26	982832-001	Warning Tag	1
13	612999-001	Blade Screw	1	27	982829-001	Optional Dust Nozzle Assembly – Not Shown	
14	621433-018	Carriage Bolt (1/4-20 x 3-3/4 in.)	1		972000-823	Owner's Manual	

* Standard Hardware Item — May Be Purchased Locally
 ** Available From Div. 98 — Source 980.00
 *** Complete Assortment Available At Your Nearest Sears Retail Store



CRAFTSMAN CIRCULAR SAW – MODEL NUMBER 315.108410

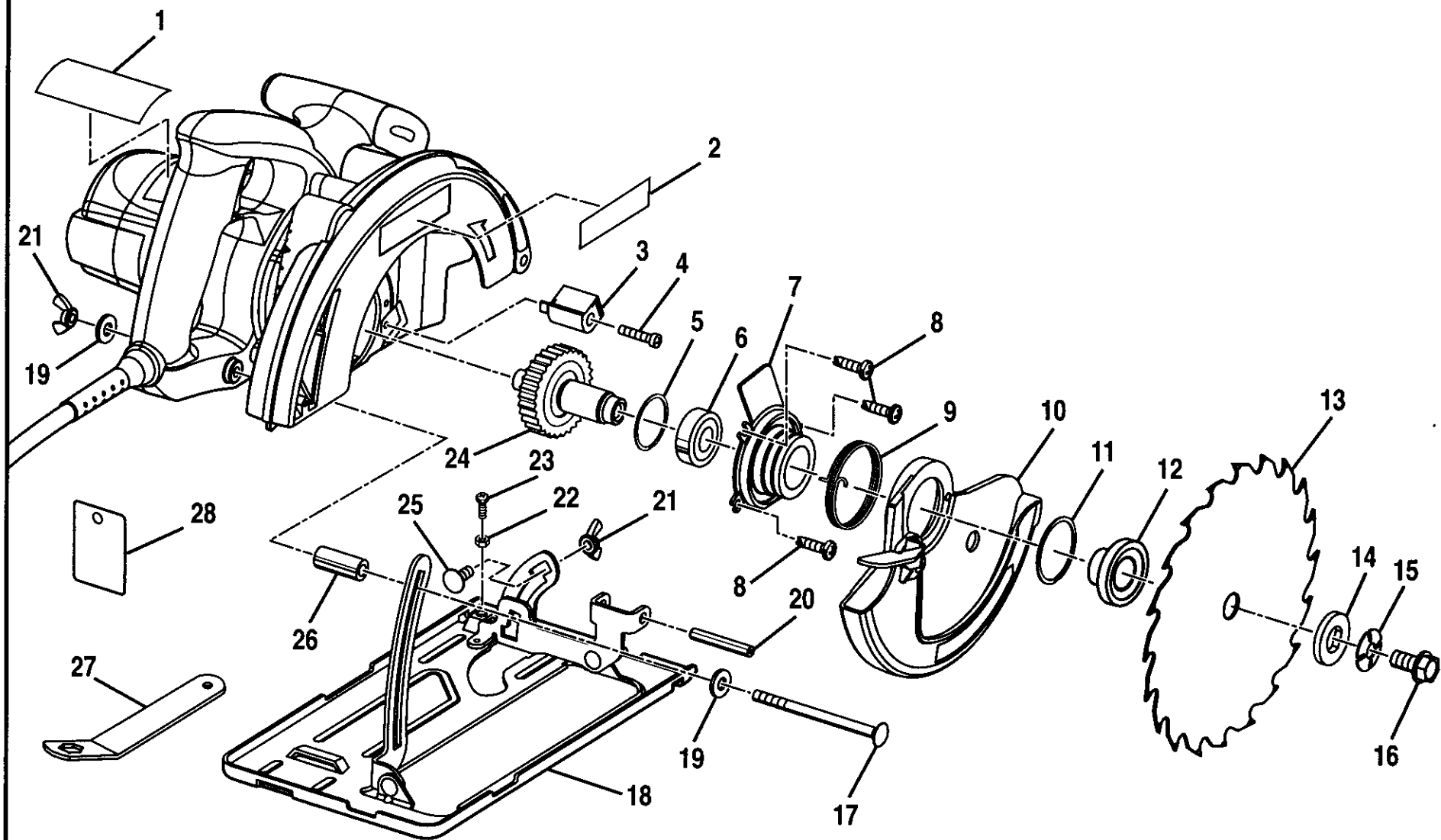

CRAFTSMAN CIRCULAR SAW – MODEL NUMBER 315.108410

The model number will be found on a plate attached to the motor housing. Always mention the model number in all correspondence regarding your **CIRCULAR SAW** or when ordering repair parts.

SEE BACK PAGE FOR PARTS ORDERING INSTRUCTIONS

PARTS LIST

Key No.	Part Number	Description	Quan.	Key No.	Part Number	Description	Quan.
1	982596-001	Data Plate	1	16	612999-001	Blade Screw	1
2	982820-001	Logo Plate	1	17	621433-007	Carriage Bolt (1/4-20 x 4 in.)	1
3	974900-001	Bumper	1	18	3053002	Base Assembly	1
4	982492-131	* Screw (#8-32 x 3/4 in. Fil. Hd.)	1	19	931744-059	Flat Washer	2
5	617096-002	Retaining Ring	1	20	941401-310	Roll Pin	1
6	**STD315535	Ball Bearing	1	21	621438-006	Wing Nut **STD541625	2
7	982828-001	Lower Blade Guard Support	1	22	706404-007	Hex Nut (#8-32) **STD541008	1
8	610122-003	* Screw (#8-32 x 3/8 in. Pan Hd.)	3	23	614658-010	* Screw (#8-32 x 5/8 in. Pan Hd.)	1
9	967952-001	Torsion Spring	1	24	982821-001	Gear and Spindle Assembly	1
10	982380-001	Lower Blade Guard Assembly	1	25	621433-001	Carriage Bolt (1/4-20 x 5/8 in.) **STD532507	1
11	718602-804	Retaining Ring	1	26	982366-002	Spacer	1
12	967887-003	Inner Flange Bushing	1	27	974716-001	Wrench	1
13	***	Saw Blade 7-1/4 in. for 5/8 in. Arbor	1	28	982832-001	Warning Tag	1
14	998463-001	Outer Blade Washer	1	29	982829-001	Optional Dust Nozzle Assembly– Not Shown	
15	623547-002	Spring Washer	1		972000-823	Owner's Manual	

- * Standard Hardware Item — May Be Purchased Locally
- ** Available From Div.98 — Source 980.00
- *** Complete Assortment Available At Your Nearest Sears Retail Store



Get it fixed, at your home or ours!

For repair of major brand appliances **in your own home...**
no matter who made it, no matter who sold it!

1-800-4-MY-HOMESM Anytime, day or night
(1-800-469-4663)

www.sears.com

To bring in products such as vacuums, lawn equipment and electronics
for repair, call for the location of your nearest **Sears Parts & Repair Center.**

1-800-488-1222 Anytime, day or night

www.sears.com

For the replacement parts, accessories and owner's manuals
that you need to do-it-yourself, call **Sears PartsDirectSM**!

1-800-366-PART 6 a.m. – 11 p.m. CST,
(1-800-366-7278) 7 days a week

www.sears.com/partsdirect

To purchase or inquire about a Sears Service Agreement:

1-800-827-6655

7 a.m. – 5 p.m. CST, Mon. – Sat.

Para pedir servicio de reparación a domicilio,
y para ordenar piezas con entrega a domicilio

1-888-SU-HOGARSM
(1-888-784-6427)

Au Canada pour service en français:

1-877-LE-FOYERSM
(1-877-533-6937)

