

Operator's Manual

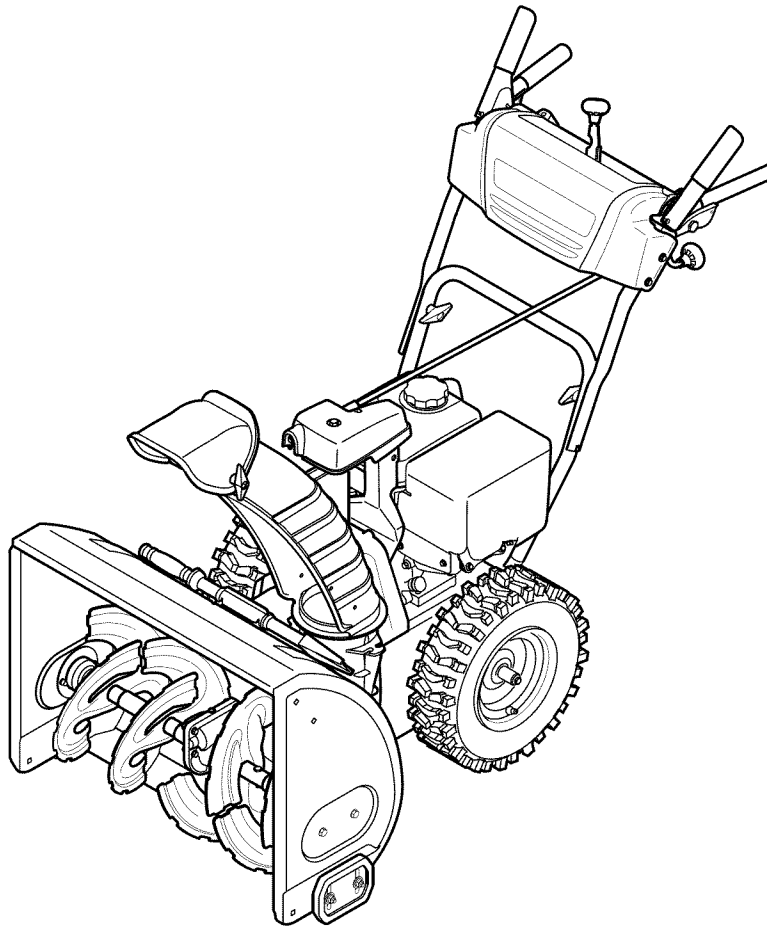

24" SNOW THROWER

Model No. 247.881731



CAUTION: Before using this product, read this manual and follow all safety rules and operating instructions.

- SAFETY
- ASSEMBLY
- OPERATION
- MAINTENANCE
- PARTS LIST
- ESPAÑOL

Sears Brands Management Corporation, Hoffman Estates, IL 60179, U.S.A.

Visit our website: www.craftsman.com

Form No. 769-08174C
(June 21, 2013)

TABLE OF CONTENTS

Warranty Statement.....	Page 2	Off-Season Storage.....	Page 23
Safe Operation Practices	Pages 3-6	Troubleshooting	Page 24
Assembly	Pages 8-11	Parts List.....	Pages 26-43
Operation	Pages 12-15	Repair Protection Agreement.....	Page 46
Service & Maintenance.....	Pages 16-22	Español.....	Page 47

WARRANTY STATEMENT

CRAFTSMAN TWO YEAR FULL WARRANTY

FOR TWO YEARS from the date of purchase, this product is warranted against any defects in material or workmanship. Defective product will receive free repair or free replacement if repair is unavailable.

ADDITIONAL LIFETIME LIMITED WARRANTY on UPPER and LOWER CHUTE

FOR AS LONG AS IT IS USED by the original owner after the second year from the date of purchase, the upper and lower chute of this snow thrower are warranted against any defects in material or workmanship as verified by a Sears authorized service provider. With proof of purchase, you will receive a new chute free of charge. You are responsible for the labor cost of installation and any cost incurred to verify the defect.

For warranty coverage details to obtain repair or replacement, visit the web site: www.craftsman.com

This warranty covers ONLY defects in material and workmanship. Warranty coverage does NOT include:

- Expendable items that can wear out from normal use within the warranty period, including but not limited to augers, auger paddles, drift cutters, skid shoes, shave plate, shear pins, spark plug, air cleaner, belts, and oil filter.
- Standard maintenance servicing, oil changes, or tune-ups.
- Tire replacement or repair caused by punctures from outside objects, such as nails, thorns, stumps, or glass.
- Tire or wheel replacement or repair resulting from normal wear, accident, or improper operation or maintenance.
- Repairs necessary because of operator abuse, including but not limited to damage caused by over-speeding the engine, or from impacting objects that bend the frame, auger shaft, etc.
- Repairs necessary because of operator negligence, including but not limited to, electrical and mechanical damage caused by improper storage, failure to use the proper grade and amount of engine oil, or failure to maintain the equipment according to the instructions contained in the operator's manual.
- Engine (fuel system) cleaning or repairs caused by fuel determined to be contaminated or oxidized (stale). In general, fuel should be used within 30 days of its purchase date.
- Normal deterioration and wear of the exterior finishes, or product label replacement.

This warranty is void if this product is ever used while providing commercial services or if rented to another person.

This warranty gives you specific legal rights, and you may also have other rights which vary from state to state.

Sears Brands Management Corporation, Hoffman Estates, IL 60179

PRODUCT SPECIFICATIONS

Engine Oil: 5W-30
Fuel: Unleaded Gasoline
Engine: MTD

MODEL NUMBER

Model Number _____
Serial Number _____
Date of Purchase _____

Record the model number, serial number,
and date of purchase above.

SAFETY INSTRUCTIONS

WARNING

This symbol points out important safety instructions which, if not followed, could endanger the personal safety and/or property of yourself and others. Read and follow all instructions in this manual before attempting to operate this machine. Failure to comply with these instructions may result in personal injury. When you see this symbol, **HEED ITS WARNING!**

WARNING

CALIFORNIA PROPOSITION 65

Engine Exhaust, some of its constituents, and certain vehicle components contain or emit chemicals known to State of California to cause cancer and birth defects or other reproductive harm.

DANGER

This machine was built to be operated according to the safe operation practices in this manual. As with any type of power equipment, carelessness or error on the part of the operator can result in serious injury. This machine is capable of amputating fingers, hands, toes and feet and throwing debris. Failure to observe the following safety instructions could result in serious injury or death.

WARNING

Your Responsibility—Restrict the use of this power machine to persons who read, understand and follow the warnings and instructions in this manual and on the machine.

SAVE THESE INSTRUCTIONS!

TRAINING

- Read, understand, and follow all instructions on the machine and in the manual(s) before attempting to assemble and operate. Failure to do so can result in serious injury to the operator and/or bystanders. Keep this manual in a safe place for future and regular reference and for ordering replacement parts.
- Be familiar with all controls and their proper operation. Know how to stop the machine and disengage them quickly.
- Never allow children under 14 years of age to operate this machine. Children 14 and over should read and understand the instructions and safe operation practices in this manual and on the machine and be trained and supervised by an adult.
- Never allow adults to operate this machine without proper instruction.
- Thrown objects can cause serious personal injury. Plan your snow-throwing pattern to avoid discharge of material toward roads, bystanders and the like.
- Keep bystanders, pets and children at least 75 feet from the machine while it is in operation. Stop machine if anyone enters the area.
- Exercise caution to avoid slipping or falling, especially when operating in reverse.

PREPARATION

- Thoroughly inspect the area where the equipment is to be used. Remove all doormats, newspapers, sleds, boards, wires and other foreign objects, which could be tripped over or thrown by the auger/impeller.
- Always wear safety glasses or eye shields during operation and while performing an adjustment or repair to protect your eyes. Thrown objects which ricochet can cause serious injury to the eyes.
- Do not operate without wearing adequate winter outer garments. Do not wear jewelry, long scarves or other loose clothing, which could become entangled in moving parts. Wear footwear which will improve footing on slippery surfaces.
- Use a grounded three-wire extension cord and receptacle for all machines with electric start engines.

- Disengage all control levers before starting the engine.
- Adjust collector housing height to clear gravel or crushed rock surfaces.
- Never attempt to make any adjustments while engine is running, except where specifically recommended in the operator's manual.
- Let engine and machine adjust to outdoor temperature before starting to clear snow.

Safe Handling of Gasoline:

To avoid personal injury or property damage use extreme care in handling gasoline. Gasoline is extremely flammable and the vapors are explosive. Serious personal injury can occur when gasoline is spilled on yourself or your clothes which can ignite. Wash your skin and change clothes immediately.

- Use only an approved gasoline container.
- Never fill containers inside a vehicle or on a truck or trailer bed with a plastic liner. Always place containers on the ground away from your vehicle before filling.
- When practical, remove gas-powered equipment from the truck or trailer and refuel it on the ground. If this is not possible, then refuel such equipment on a trailer with a portable container, rather than from a gasoline dispenser nozzle.
- Keep the nozzle in contact with the rim of the fuel tank or container opening at all times until fueling is complete. Do not use a nozzle lock-open device.
- Extinguish all cigarettes, cigars, pipes and other sources of ignition.
- Never fuel machine indoors.
- Never remove gas cap or add fuel while the engine is hot or running. Allow engine to cool at least two minutes before refueling.
- Never over fill fuel tank. Fill tank to no more than ½ inch below bottom of filler neck to allow space for fuel expansion.
- Replace gasoline cap and tighten securely.
- If gasoline is spilled, wipe it off the engine and equipment. Move unit to another area. Wait 5 minutes before starting the engine.

SAFETY INSTRUCTIONS

- To reduce fire hazards, keep machine free of grass, leaves, or other debris build-up. Clean up oil or fuel spillage and remove any fuel soaked debris.
- Never store the machine or fuel container inside where there is an open flame, spark or pilot light as on a water heater, space heater, furnace, clothes dryer or other gas appliances.

OPERATION

- Do not put hands or feet near rotating parts, in the auger/impeller housing or chute assembly. Contact with the rotating parts can amputate hands and feet.
- The auger/impeller control lever is a safety device. Never bypass its operation. Doing so makes the machine unsafe and may cause personal injury.
- The control levers must operate easily in both directions and automatically return to the disengaged position when released.
- Never operate with a missing or damaged chute assembly. Keep all safety devices in place and working.
- Never run an engine indoors or in a poorly ventilated area. Engine exhaust contains carbon monoxide, an odorless and deadly gas.
- Do not operate machine while under the influence of alcohol or drugs.
- Muffler and engine become hot and can cause a burn. Do not touch. Keep children away.
- Exercise extreme caution when operating on or crossing gravel surfaces. Stay alert for hidden hazards or traffic.
- Exercise caution when changing direction and while operating on slopes. Do not operate on steep slopes.
- Plan your snow-throwing pattern to avoid discharge towards windows, walls, cars etc. Thus, avoiding possible property damage or personal injury caused by a ricochet.
- Never direct discharge at children, bystanders and pets or allow anyone in front of the machine.
- Do not overload machine capacity by attempting to clear snow at too fast of a rate.
- Never operate this machine without good visibility or light. Always be sure of your footing and keep a firm hold on the handles. Walk, never run.
- Disengage power to the auger/impeller when transporting or not in use.
- Never operate machine at high transport speeds on slippery surfaces. Look down and behind and use care when backing up.
- If the machine should start to vibrate abnormally, stop the engine, disconnect the spark plug wire and ground it against the engine. Inspect thoroughly for damage. Repair any damage before starting and operating.
- Disengage all control levers and stop engine before you leave the operating position (behind the handles). Wait until the auger/impeller comes to a complete stop before unlogging the chute assembly, making any adjustments, or inspections.
- Never put your hand in the discharge or collector openings. Do not unlog chute assembly while engine is running. Shut off engine and remain behind handles until all moving parts have stopped before unlogging.

- Use only attachments and accessories approved by the manufacturer (e.g. wheel weights, tire chains, cabs etc.).
- When starting engine, pull cord slowly until resistance is felt, then pull rapidly. Rapid retraction of starter cord (kickback) will pull hand and arm toward engine faster than you can let go. Broken bones, fractures, bruises or sprains could result.
- If situations occur which are not covered in this manual, use care and good judgment.

CLEARING A CLOGGED DISCHARGE CHUTE

Hand contact with the rotating impeller inside the discharge chute is the most common cause of injury associated with snow throwers. Never use your hand to clean out the discharge chute.

To clear the chute:

- a. SHUT THE ENGINE OFF!
- b. Wait 10 seconds to be sure the impeller blades have stopped rotating.
- c. Always use a clean-out tool, not your hands.

MAINTENANCE & STORAGE

- Never tamper with safety devices. Check their proper operation regularly. Refer to the maintenance and adjustment sections of this manual.
- Before cleaning, repairing, or inspecting machine disengage all control levers and stop the engine. Wait until the auger/impeller come to a complete stop. Disconnect the spark plug wire and ground against the engine to prevent unintended starting.
- Check bolts and screws for proper tightness at frequent intervals to keep the machine in safe working condition. Also, visually inspect machine for any damage.
- Do not change the engine governor setting or over-speed the engine. The governor controls the maximum safe operating speed of the engine.
- Snow thrower shave plates and skid shoes are subject to wear and damage. For your safety protection, frequently check all components and replace with original equipment manufacturer's (OEM) parts only as listed in the Parts pages of this operator's manual. Use of parts which do not meet the original equipment specifications may lead to improper performance and compromise safety!
- Check control levers periodically to verify they engage and disengage properly and adjust, if necessary. Refer to the adjustment section in this operator's manual for instructions.
- Maintain or replace safety and instruction labels, as necessary.
- Observe proper disposal laws and regulations for gas, oil, etc. to protect the environment.
- Prior to storing, run machine a few minutes to clear snow from machine and prevent freeze up of auger/impeller.
- Never store the machine or fuel container inside where there is an open flame, spark or pilot light such as a water heater, furnace, clothes dryer etc.
- Always refer to the operator's manual for proper instructions on off-season storage.

SAFETY INSTRUCTIONS

- Check fuel line, tank, cap, and fittings frequently for cracks or leaks. Replace if necessary.
- Do not crank engine with spark plug removed.
- According to the Consumer Products Safety Commission (CPSC) and the U.S. Environmental Protection Agency (EPA), this product has an *Average Useful Life* of seven (7) years, or 60 hours of operation. At the end of the *Average Useful Life* have the machine inspected annually by an authorized service dealer to ensure that all mechanical and safety systems are working properly and not worn excessively. Failure to do so can result in accidents, injuries or death.

DO NOT MODIFY ENGINE

To avoid serious injury or death, do not modify engine in any way. Tampering with the governor setting can lead to a runaway engine and cause it to operate at unsafe speeds. Never tamper with factory setting of engine governor.

NOTICE REGARDING EMISSIONS

Engines which are certified to comply with California and federal EPA emission regulations for SORE (Small Off Road Equipment) are certified to operate on regular unleaded gasoline, and may include the following emission control systems: Engine Modification (EM), Oxidizing Catalyst (OC), Secondary Air Injection (SAI) and Three Way Catalyst (TWC) if so equipped.

SPARK ARRESTOR

WARNING

This machine is equipped with an internal combustion engine and should not be used on or near any unimproved forest-covered, brushcovered or grass-covered land unless the engine's exhaust system is equipped with a spark arrestor meeting applicable local or state laws (if any).







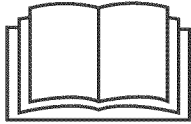

If a spark arrestor is used, it should be maintained in effective working order by the operator. In the State of California the above is required by law (Section 4442 of the California Public Resources Code). Other states may have similar laws. Federal laws apply on federal lands.

A spark arrestor for the muffler is available through your nearest Sears Parts and Repair Service Center.

SAFETY INSTRUCTIONS

SAFETY SYMBOLS

This page depicts and describes safety symbols that may appear on this product. Read, understand, and follow all instructions on the machine before attempting to assemble and operate.

Symbol	Description
	READ THE OPERATOR'S MANUAL(S) Read, understand, and follow all instructions in the manual(s) before attempting to assemble and operate
	WARNING— ROTATING BLADES Keep hands out of inlet and discharge openings while machine is running. There are rotating blades inside
	WARNING— ROTATING BLADES Keep hands out of inlet and discharge openings while machine is running. There are rotating blades inside
	WARNING— ROTATING AUGER Do not put hands or feet near rotating parts, in the auger/impeller housing or chute assembly. Contact with the rotating parts can amputate hands and feet.
	WARNING—THROWN OBJECTS This machine may pick up and throw and objects which can cause serious personal injury.
	WARNING— GASOLINE IS FLAMMABLE Allow the engine to cool at least two minutes before refueling.
	WARNING— CARBON MONOXIDE Never run an engine indoors or in a poorly ventilated area. Engine exhaust contains carbon monoxide, an odorless and deadly gas.
	WARNING— ELECTRICAL SHOCK Do not use the engine's electric starter in the rain
	WARNING— HOT SURFACE Engine parts, especially the muffler, become extremely hot during operation. Allow engine and muffler to cool before touching.



WARNING: Your Responsibility—Restrict the use of this power machine to persons who read, understand and follow the warnings and instructions in this manual and on the machine.

SAVE THESE INSTRUCTIONS!

This page left intentionally blank.

ASSEMBLY

NOTE: References to right or left side of the snow thrower are determined from behind the unit in the operating position (standing directly behind the snow thrower, facing the handle panel).

Removing From Carton

1. Cut the corners of the carton and lay the sides flat on the ground. Remove and discard all packing inserts.
2. Move the snow thrower out of the carton.
3. Make certain the carton has been completely emptied before discarding it.

Assembly

1. Place the shift lever in the Forward-6 position.
2. Observe the lower rear area of the snow thrower to be sure both cables are aligned with roller guides before pivoting the handle upward. See Figure 1.

NOTE: Make certain the upper ends of each cable are seated properly in its bracket.

3. Secure the handle by tightening the plastic wing knob located on both the left and right sides of the handle. See Figure 2. Remove and discard any rubber bands, if present. They are for packaging purposes only.
4. Remove wing nut and hex screw from chute control head and clevis pin and cotter pin from chute support bracket. Position chute (forward-facing) over chute base. See Figure 3.

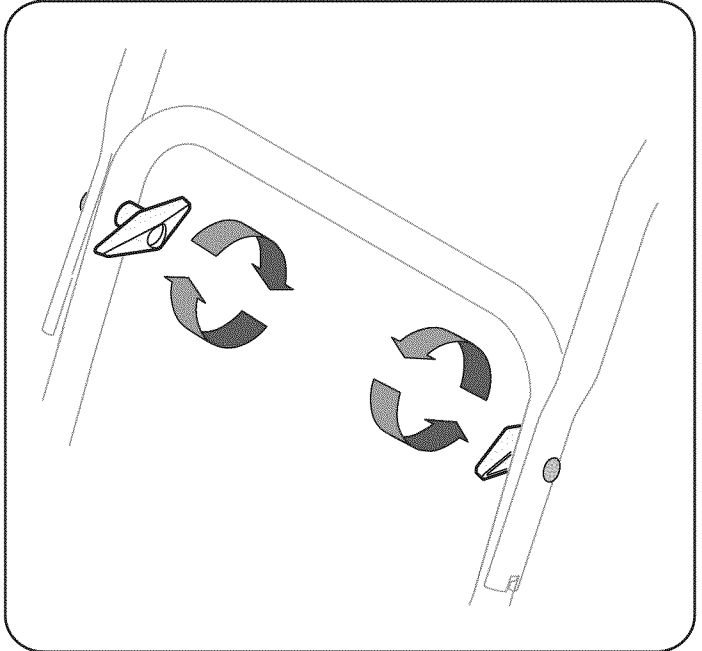

Figure 2

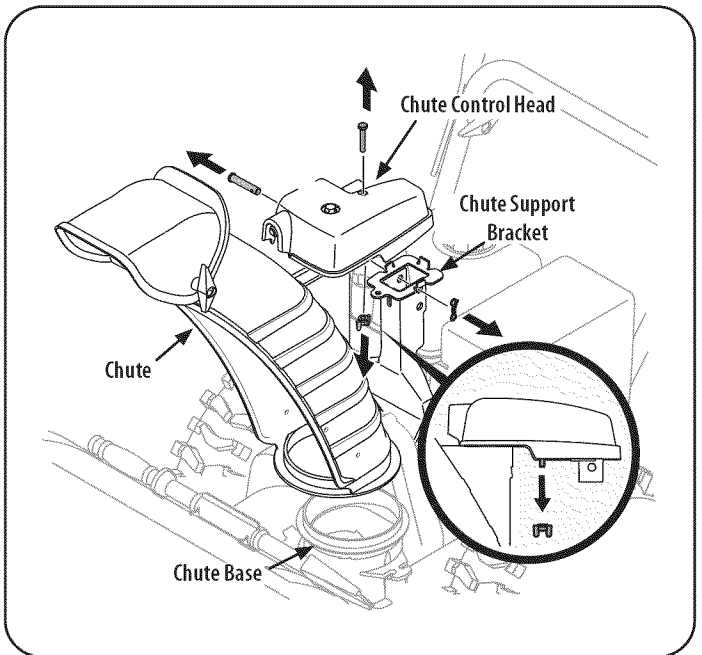

Figure 3

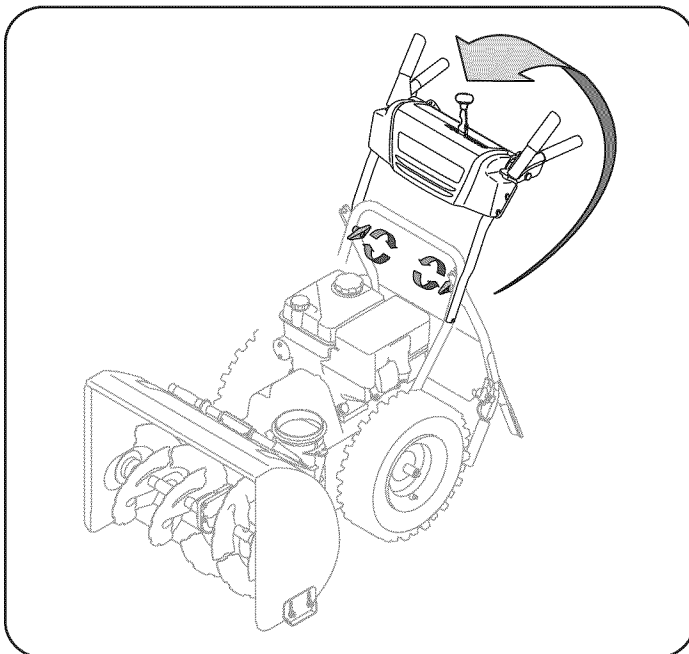

Figure 1

ASSEMBLY

5. Place chute onto chute base and secure chute control head to chute support bracket with clevis pin and cotter pin removed earlier. See Figure 4.
6. Finish securing chute control head to chute support bracket with wing nut and hex screw removed earlier. See Figure 5.
7. Insert the chute directional control into the support bracket on the rear of the dash panel. See Figure 6.
8. Remove the hairpin clip from the rear of the chute control head.
9. Insert chute directional control into rear of the chute control head. Secure the chute directional control to the chute control head with the hairpin clip removed earlier. See Figure 7.

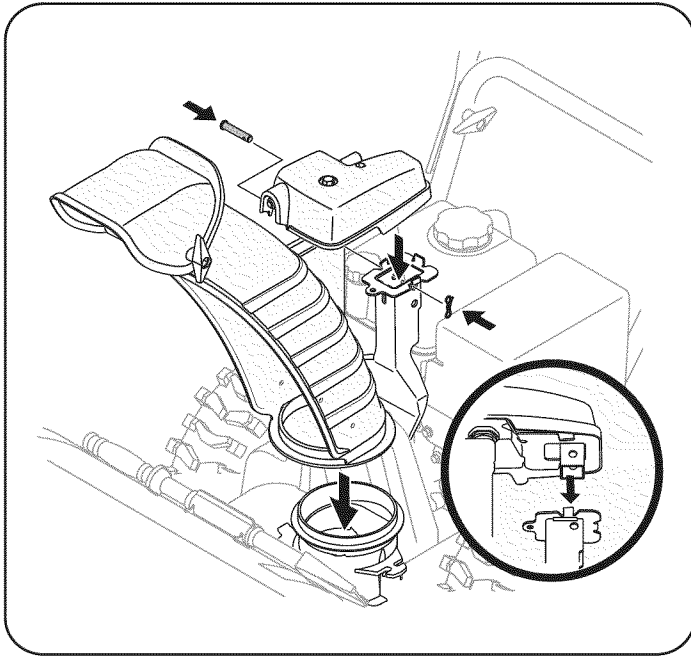

Figure 4

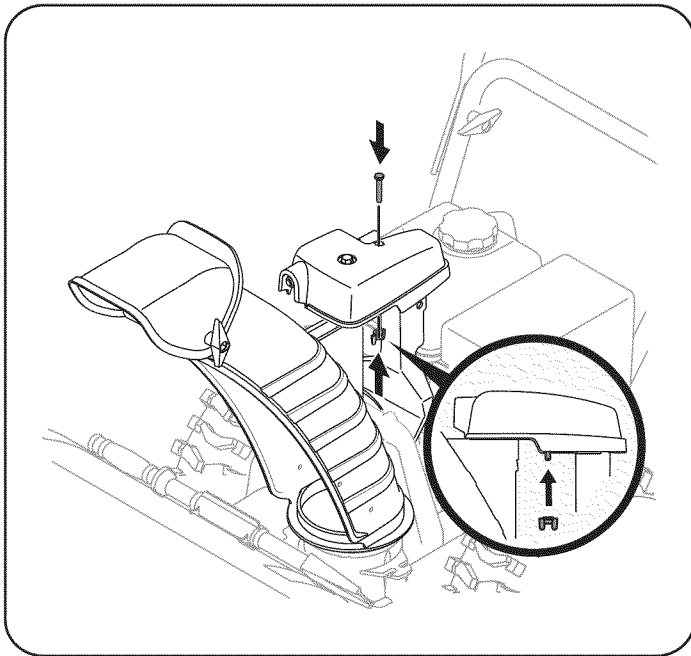

Figure 5

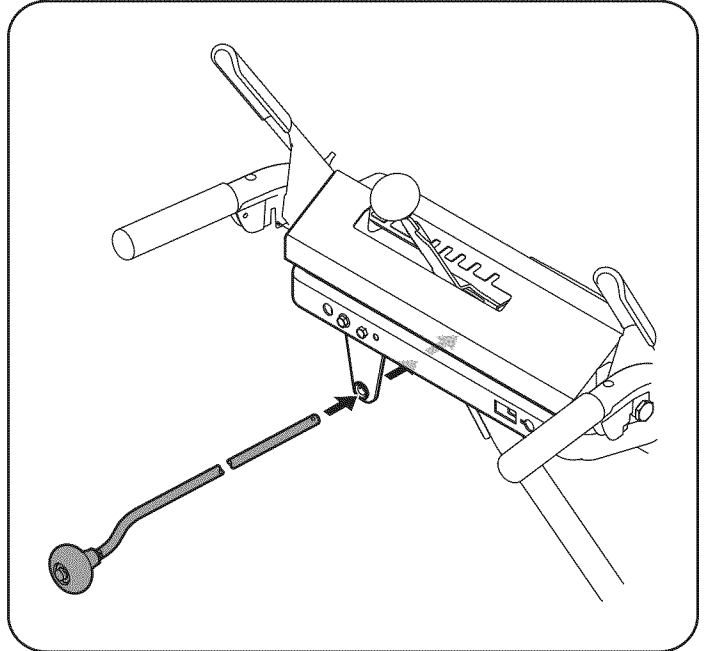

Figure 6

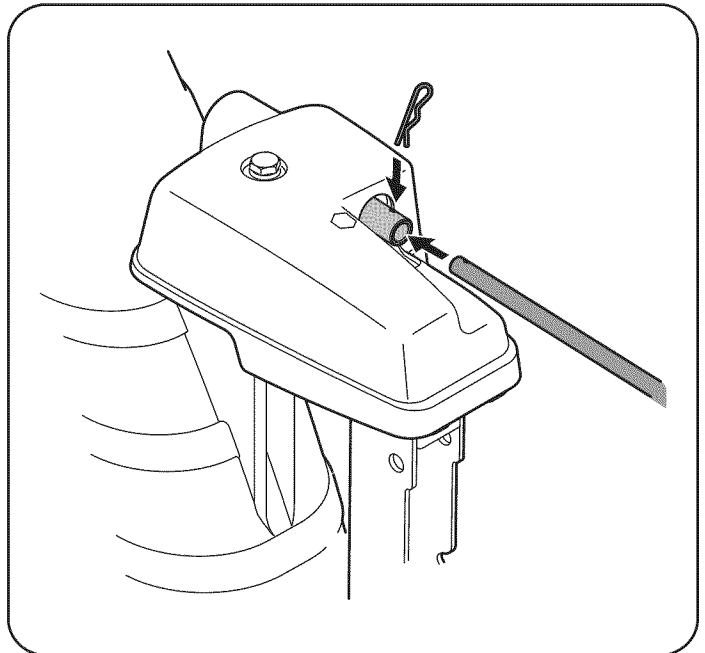

Figure 7

ASSEMBLY

Set-Up

Chute Clean-Out Tool

A chute clean-out tool is fastened to the top of the auger housing with a mounting clip. See Figure 8. The tool is designed to clear a chute assembly of ice and snow. This item is fastened with a cable tie at the factory. Cut the cable tie before operating the snow thrower.

⚠ WARNING

Never use your hands to clear a clogged chute assembly. Shut off engine and remain behind handles until all moving parts have stopped before using the clean-out tool to clear the chute assembly.

Tire Pressure

⚠ WARNING

Under any circumstance do not exceed manufacturer's recommended psi. Equal tire pressure should be maintained at all times. Excessive pressure when seating beads may cause tire/rim assembly to burst with force sufficient to cause serious injury. Refer to sidewall of tire for recommended pressure.

The tires are over-inflated for shipping purposes. Check the tire pressure before operating the snow thrower. Refer to the tire side wall for tire manufacturer's recommended psi and deflate (or inflate) the tires as necessary.

NOTE: Equal tire pressure is to be maintained at all times for performance purposes.

Adjustments

Skid Shoes

The snow thrower skid shoes are adjusted upward at the factory for shipping purposes. Adjust them downward, if desired, prior to operating the snow thrower.

⚠ CAUTION

It is not recommended that you operate this snow thrower on gravel as it can easily pick up and throw loose gravel, causing personal injury or damage to the snow thrower and surrounding property.

- For close snow removal on a smooth surface, raise skid shoes higher on the auger housing. Refer to Figure 9.
- Use a middle or lower position when the area to be cleared is uneven, such as a gravel driveway.

NOTE: If you choose to operate the snow thrower on a gravel surface, keep the skid shoes in position for maximum clearance between the ground and the shave plate.

To adjust the skid shoes:

1. Loosen the four hex nuts (two on each side) and carriage bolts. Move skid shoes to desired position. See Figure 9.
2. Make certain the entire bottom surface of skid shoe is against the ground to avoid uneven wear on the skid shoes.
3. Retighten nuts and bolts securely.

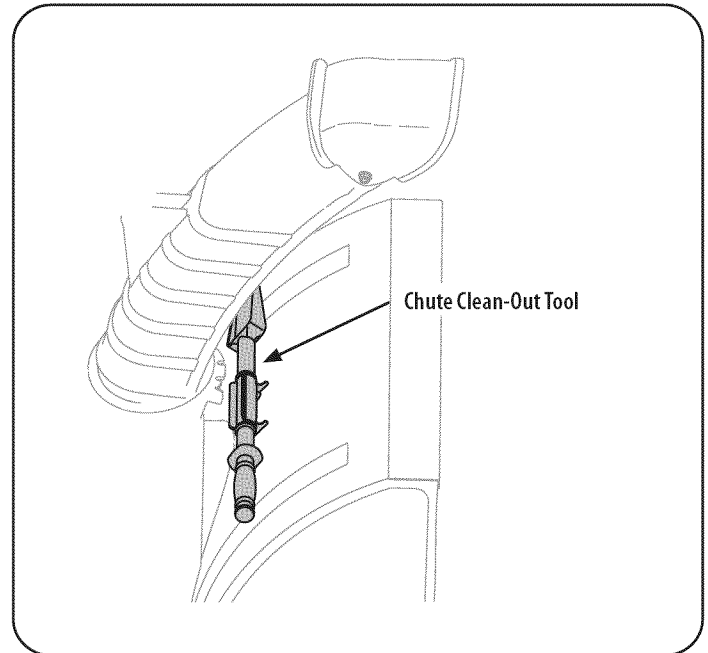

Figure 8

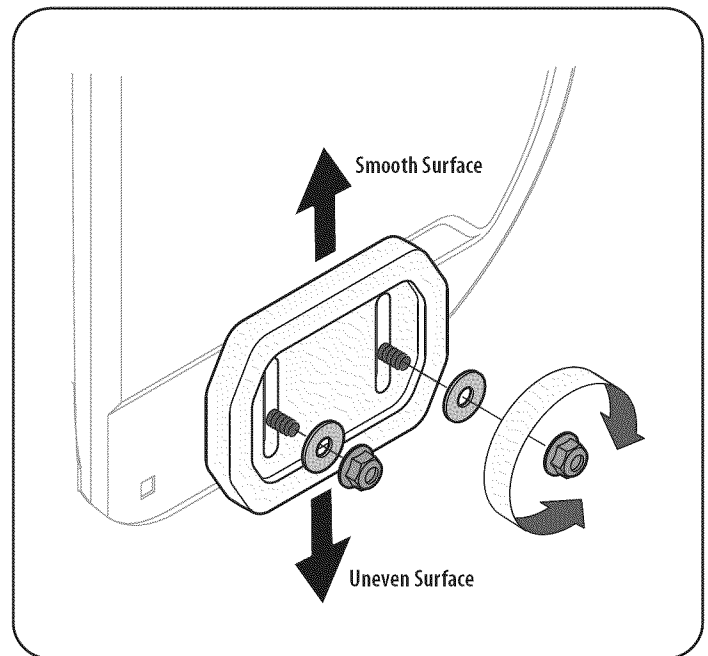

Figure 9

OPERATION

Chute

The distance snow is thrown can be adjusted by changing the angle of the upper chute. To do so:

1. Stop the engine by removing the ignition key and loosen the plastic wing knob found on the left side of the chute assembly.
2. Pivot the chute upward or downward before retightening the wing knob. See Figure 10.

Auger Control

WARNING

Prior to operating your snow thrower, carefully read and follow all instructions below. Perform all adjustments to verify your snow thrower is operating safely and properly.

Check the adjustment of the auger control as follows:

1. The auger control is located on the left handle. See Figure 11 inset. When the auger control is released and in the disengaged “up” position, the cable should have very little slack. It should NOT be tight.
2. In a well-ventilated area, start the snow thrower engine. Refer to Starting the Engine in the Operation section.
3. While standing in the operator’s position (behind the snow thrower), engage the auger.
4. Allow the auger to remain engaged for approximately ten (10) seconds before releasing the auger control. Repeat this several times.
5. With the auger control in the disengaged “up” position, walk to the front of the machine.
6. Confirm that the auger has completely stopped rotating and shows NO signs of motion. If the auger shows ANY signs of rotating, immediately return to the operator’s position and shut off the engine. Wait for ALL moving parts to stop before adjusting the auger control.
7. To readjust the control cable, loosen the upper hex bolt on the auger cable bracket. See Figure 11.
8. Position the bracket upward to provide more slack (or downward to increase cable tension).
9. Retighten the upper hex bolt.
10. Repeat steps 2-6 above to verify proper adjustment has been achieved.

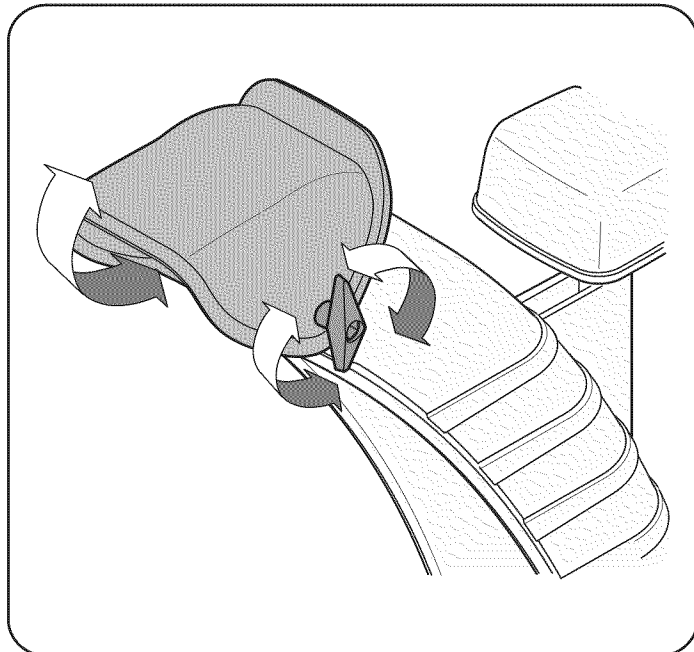

Figure 10

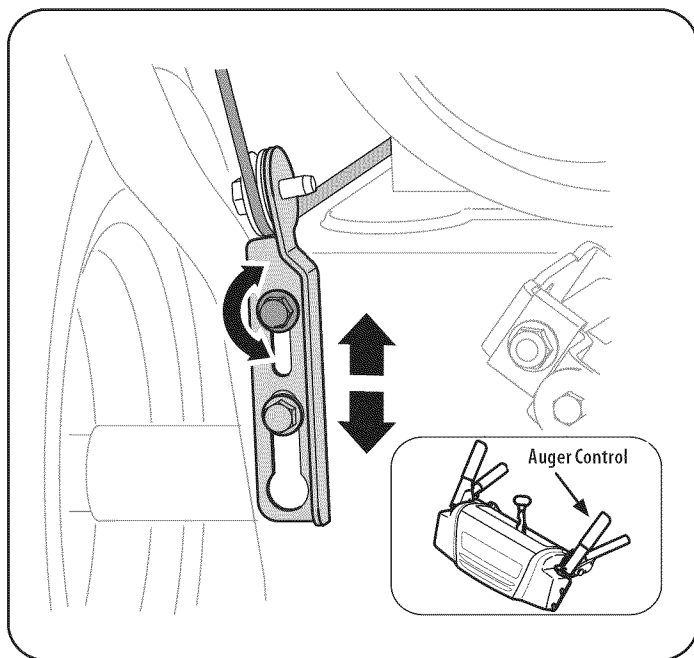

Figure 11

OPERATION

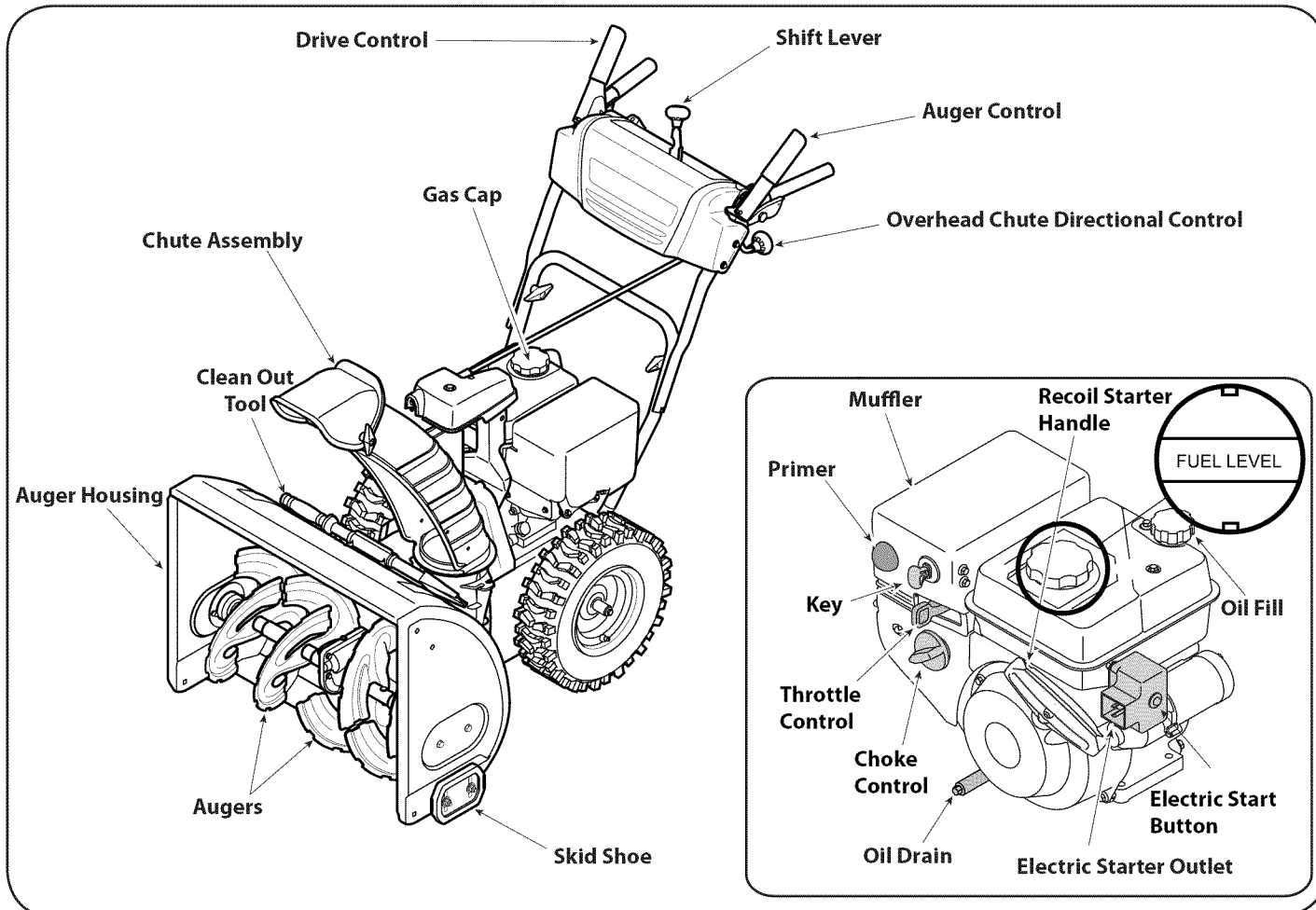
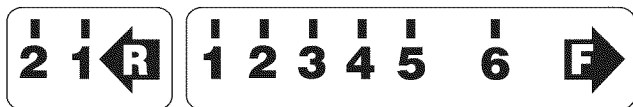

Figure 12

Now that you have set up your snow thrower, it's important to become acquainted with its controls and features. Refer to Figure 12.

Shift Lever



The shift lever is located on the dash panel. Place the shift lever into any of eight positions to control the direction of travel and ground speed.

Forward

Your snow thrower has six forward (F) speeds. Position one (1) is the slowest and position six (6) is the fastest.

Reverse

Your snow thrower has two reverse (R) speeds. One (1) is the slower and two (2) is the faster.

Key

The key is a safety device. It must be fully inserted in order for the engine to start. Remove the key when the snow thrower is not in use.

NOTE: Do not turn the ignition key in an attempt to start the engine. Doing so may cause it to break.



Choke Control

The choke control is found on the rear of the engine and is activated by turning the rotary choke knob to the CHOKE position. Activating the choke control closes the choke plate on the carburetor and aids in starting the engine.



Meets ANSI Safety Standards

Craftsman Snow Throwers conform to the safety standard of the American National Standards Institute (ANSI).

OPERATION

Throttle control



The throttle control is located on the rear of the engine. It regulates the speed of the engine and will shut off the engine when moved into the STOP position.

Primer

Depressing the primer forces fuel directly into the engine's carburetor to aid in cold-weather starting.

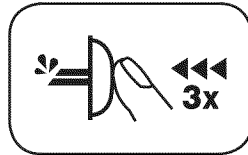

Recoil Starter Handle

This handle is used to manually start the engine.

Electric Starter Button

Pressing the electric starter button engages the engine's electric starter when plugged into a 120V power source.

Electric Starter Outlet

Requires the use of a three-prong outdoor extension cord and a 120V power source/wall outlet.

Oil Fill

Engine oil level can be checked and oil added through the oil fill.

Gas Cap

Unthread the gas cap to add gasoline to the fuel tank.

Auger

When engaged, the auger blades rotate and draw snow into the auger housing.

Chute Assembly

Snow drawn into the auger housing is discharged out the chute assembly.

Auger Control

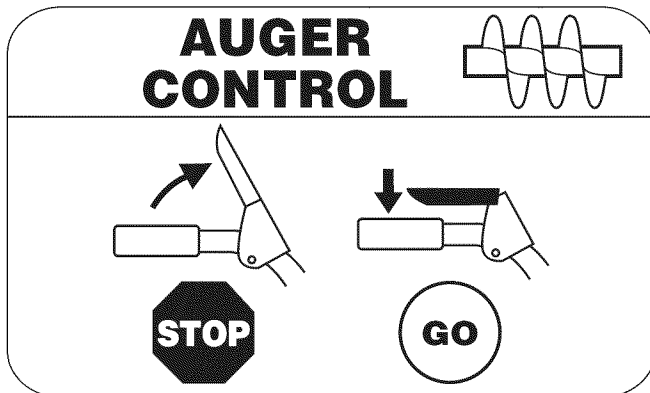

The auger control is located on the left handle. Squeeze the control grip against the handle to engage the auger and start snow throwing action. Release to stop.

Drive Control/ Auger Control Lock

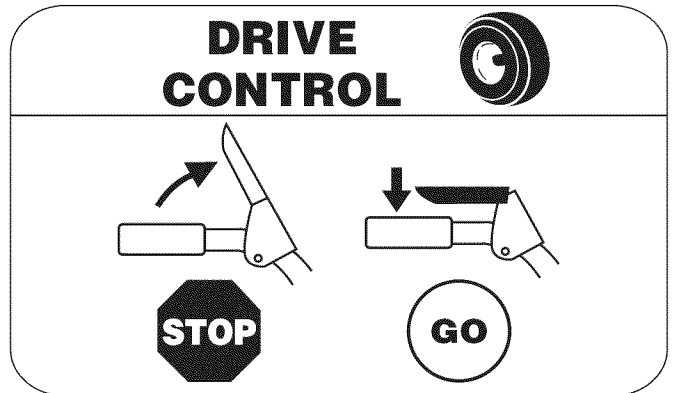

The drive control is located on the right handle. Squeeze the control grip against the handle to engage the wheel drive. Release to stop.

The drive control also locks the auger control so you can operate the chute directional control without interrupting the snow throwing process. If the auger control is engaged simultaneously with the drive control, the operator can release the auger control (on the left handle) and the augers will remain engaged. Release both controls to stop the augers and wheel drive.

NOTE: Always release the drive control before changing speeds. Failure to do so will result in increased wear on your machine's drive system.

Overhead Chute Directional Control

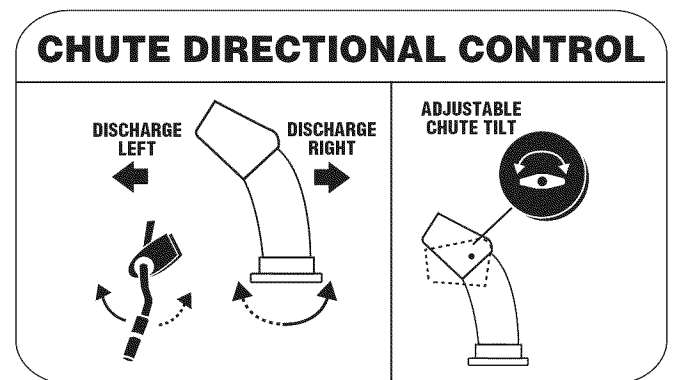

The overhead chute directional control is located in the center of the snow thrower between the handle panel and lower handle. To change the direction in which snow is thrown, rotate the chute directional control.

Skid Shoes

Position the skid shoes based on surface conditions. Adjust upward for hard-packed snow. Adjust downward when operating on gravel or crushed rock surfaces.

OPERATION

Clean-Out Tool

WARNING

Never use your hands to clear a clogged chute assembly. Shut off engine and remain behind handles until all moving parts have stopped before using the clean-out tool to clear the chute assembly.

The chute clean-out tool is conveniently fastened to the rear of the auger housing with a mounting clip. Should snow and ice become lodged in the chute assembly during operation, proceed as follows to safely clean the chute assembly and chute opening:

1. Release both the Auger Control and the Drive Control.
2. Stop the engine by removing the ignition key.
3. Remove the clean-out tool from the clip which secures it to the rear of the auger housing.
4. Use the shovel-shaped end of the clean-out tool to dislodge and scoop any snow and ice which has formed in and near the chute assembly.
5. Refasten the clean-out tool to the mounting clip on the rear of the auger housing, reinsert the ignition key and start the snow thrower's engine.
6. While standing in the operator's position (behind the snow thrower), engage the auger control for a few seconds to clear any remaining snow and ice from the chute assembly.

Before Starting Engine

WARNING

Read, understand, and follow all instructions and warnings on the machine and in this manual before operating.

Oil

The unit was shipped with oil in the engine. Check oil level before each operation to ensure adequate oil in the engine.

NOTE: Be sure to check the engine on a level surface with the engine stopped.

1. Remove the oil filler cap/dipstick and wipe the dipstick clean.
2. Insert the cap/dipstick into the oil filler neck, but do NOT screw it in.
3. Remove the oil filler cap/dipstick. If the level is low, slowly add oil (5W-30, with a minimum classification of SF/SG) until oil level registers between high (H) and low (L).

NOTE: Do not overfill. Overfilling with oil may result in engine smoking, hard starting or spark plug fouling.

4. Replace and tighten cap/dipstick firmly before starting engine.

Gasoline

Use automotive gasoline (unleaded or low leaded to minimize combustion chamber deposits) with a minimum of 87 octane. Gasoline with up to 10% ethanol or 15% MTBE (Methyl Tertiary Butyl Ether) can be used. Never use an oil/gasoline mixture or dirty gasoline. Avoid getting dirt, dust, or water in the fuel tank. DO NOT use E85 gasoline.

- Refuel in a well-ventilated area with the engine stopped. Do not smoke or allow flames or sparks in the area where the engine is refueled or where gasoline is stored.

- Do not overfill the fuel tank. After refueling, make sure the tank cap is closed properly and securely.
- Be careful not to spill fuel when refueling. Spilled fuel or fuel vapor may ignite. If any fuel is spilled, make sure the area is dry before starting the engine.
- Avoid repeated or prolonged contact with skin or breathing of vapor.

WARNING

Use extreme care when handling gasoline. Gasoline is extremely flammable and the vapors are explosive. Never fuel the machine indoors or while the engine is hot or running. Extinguish cigarettes, cigars, pipes and other sources of ignition.

1. Clean around fuel fill before removing cap to fuel.
2. A fuel level indicator is located in the fuel tank. See Figure 12 inset. Be careful not to overfill. Fill tank until fuel reaches the fuel level indicator to allow space for fuel expansion.

Starting The Engine

WARNING

Always keep hands and feet clear of moving parts. Do not use a pressurized starting fluid. Vapors are flammable.

NOTE: Allow the engine to warm up for a few minutes after starting. The engine will not develop full power until it reaches operating temperatures.

1. Make certain both the auger control and drive control are in the disengaged (released) position.
2. Insert key into slot. Make sure it snaps into place. Do not attempt to turn the key.

NOTE: The engine cannot start without the key fully inserted into the ignition switch.

Electric Starter

WARNING

The electric starter is equipped with a grounded plug, and is designed to operate on 120 volt AC household current. It must be used with a properly grounded three-prong receptacle at all times to avoid the possibility of electric shock. Follow all instructions carefully prior to operating the electric starter. DO NOT use electric starter in the rain.

Determine that your home's wiring is a three-wire grounded system. Ask a licensed electrician if you are not certain.



If you have a grounded three-prong receptacle, proceed as follows. If you do not have the proper house wiring, DO NOT use the electric starter under any conditions.

1. Plug an extension cord into the outlet located on the engine's surface. Plug the other end of extension cord into a three-prong 120-volt, grounded, AC outlet in a well-ventilated area.

CAUTION

The extension cord can be any length, but **must** be rated for 15 amps at 125 volts, grounded and rated for outdoor use.



OPERATION

2. Move throttle control to FAST (rabbit)  position.
3. Move choke to the CHOKE  position (cold engine start). If engine is warm, place choke in RUN position.
4. Push primer three (3) times, making sure to cover vent hole in primer bulb when pushing. If engine is warm, push primer only once. Always cover vent hole when pushing. Cool weather may require priming to be repeated.
5. Push starter button to start engine. Once the engine starts, immediately release starter button. Electric starter is equipped with thermal overload protection; system will temporarily shut-down to allow starter to cool if electric starter becomes overloaded.
6. As the engine warms, slowly rotate the choke control to RUN position. If the engine falters, restart engine and run with choke at half-choke position for a short period of time, and then slowly rotate the choke into RUN position.
7. After engine is running, disconnect power cord from electric starter. When disconnecting, always unplug the end at the wall outlet before unplugging the opposite end from the engine.

Recoil Starter

CAUTION

Do not pull the starter handle while the engine running.

1. Move throttle control to FAST (rabbit)  position.
2. Move choke to the CHOKE  position (cold engine start). If engine is warm, place choke in RUN position.
3. Push primer three (3) times, making sure to cover vent hole when pushing. If engine is warm, push primer only once. Always cover vent hole when pushing. Cool weather may require priming to be repeated.
4. Pull gently on the starter handle until it begins to resist, then pull quickly and forcefully to overcome the compression. Do not release the handle and allow it to snap back. Return rope SLOWLY to original position. If required, repeat this step.
5. As the engine warms, slowly rotate the choke control to RUN position. If the engine falters, restart engine and run with choke at half-choke position for a short period of time, and then slowly rotate the choke into RUN position.

WARNING

To avoid unsupervised engine operation, never leave the machine unattended with the engine running. Turn the engine off after use and remove key.

Stopping The Engine

After you have finished snow-throwing, run engine for a few minutes before stopping to help dry off any moisture on the engine.

1. Move throttle control to OFF position.
2. Remove the key. Removing the key will reduce the possibility of unauthorized starting of the engine while equipment is not in use. Keep the key in a safe place. The engine cannot start without the key.
3. Wipe any moisture away from the controls on the engine.

To Engage Drive

1. With the throttle control in the Fast (rabbit)  position, move shift lever into one of the six forward (F) positions or two reverse (R) positions. Select a speed appropriate for the snow conditions and a pace you're comfortable with.

NOTE: When selecting a Drive Speed, use the slower speeds until you are comfortable and familiar with the operation of the snow thrower.

2. Squeeze the drive control against the handle and the snow thrower will move. Release it and drive motion will stop.

NOTE: NEVER reposition the shift lever (change speeds or direction of travel) without first releasing the drive control and bringing the snow thrower to a complete stop. Doing so will result in premature wear to the snow thrower's drive system.

To Engage Auger

1. To engage the auger and start throwing snow, squeeze the auger control against the left handle. Release to stop the auger.

Replacing Shear Pins

Each auger blade is secured to the spiral shaft with a shear pin and bow-tie clip. If an auger blade strikes a foreign object or ice jam, the pin will shear off to prevent damage to the blade. If an auger blade does not turn, check to see if its pin has sheared off. See Figure 13.

CAUTION

NEVER replace the auger shear pins with anything other than Sears SKU# 88389/OEM Part No. 738-04124A replacement shear pins. Any damage to the auger gearbox or other components as a result of failing to do so will NOT be covered by your snow thrower's warranty.

WARNING

Always turn off the snow thrower's engine and remove the key prior to replacing shear pins.

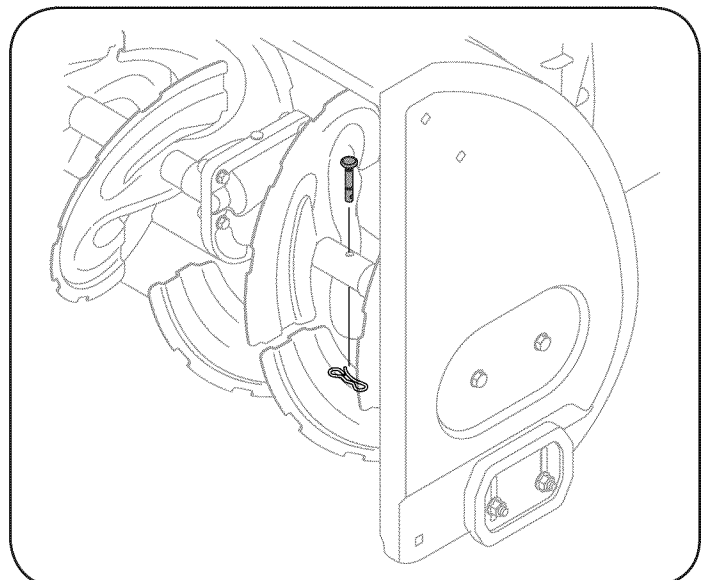

Figure 13

SERVICE AND MAINTENANCE

MAINTENANCE SCHEDULE

⚠ WARNING

Before performing any type of maintenance/service, disengage all controls and stop the engine. Wait until all moving parts have come to a complete stop. Disconnect spark plug wire and ground it against the engine to prevent unintended starting.

Follow the maintenance schedule given below. This chart describes service guidelines only. Use the Service Log column to keep track of completed maintenance tasks. To locate the nearest Sears Service Center or to schedule service, simply contact Sears at 1-800-4-MY-HOME®.

Interval	Item	Service	Service Log
Each Use and every 5 hours	1. Engine oil level 2. Loose or missing hardware 3. Unit and engine.	1. Check 2. Tighten or replace 3. Clean	
1st 5 hours	1. Engine oil	1. Change	
Annually or 25 hours	1. Spark plug 2. Control linkages and pivots 3. Wheels 4. Gear shaft and Auger shaft	1. Check 2. Lube with light oil 3. Lube with multipurpose auto grease 4. Lube with light oil	
Annually or 50 hours	1. Engine oil	1. Change	
Annually or 100 hours	1. Spark plug	1. Change	
Before Storage	1. Fuel system	1. Run engine until it stops from lack of fuel	

GENERAL RECOMMENDATIONS

Checking Engine Oil

⚠ WARNING

Before lubricating, repairing, or inspecting, disengage all controls and stop engine. Wait until all moving parts have come to a complete stop.

NOTE: Check the oil level before each use to be sure correct oil level is maintained.

When adding oil to the engine, refer to viscosity chart below. Engine oil capacity is 600 ml (approx. 20 oz.). Do not over-fill. Use a 4-stroke, or an equivalent high detergent, premium quality motor oil certified to meet or exceed U.S. automobile manufacturer's requirements for service classification SG, SF. Motor oils classified SG, SF will show this designation on the container.

1. Remove the oil filler cap/dipstick and wipe the dipstick clean.
2. Insert the cap/dipstick into the oil filler neck, but do NOT screw it in.
3. Remove the oil filler cap/dipstick. If level is low, slowly add oil until oil level registers between high (H) and low (L). See Figure 14.
4. Replace and tighten cap/dipstick firmly before starting engine.

Changing Engine Oil

NOTE: Change the engine oil after the first 5 hours of operation and once a season or every 50 hours thereafter.

1. Drain fuel from tank by running engine until the fuel tank is empty. Be sure fuel fill cap is secure.
2. Place suitable oil collection container under oil drain plug.
3. Remove oil drain plug. See Figure 15 on next page.
4. Tip unit to drain oil into the container. Used oil must be disposed of at a proper collection center.

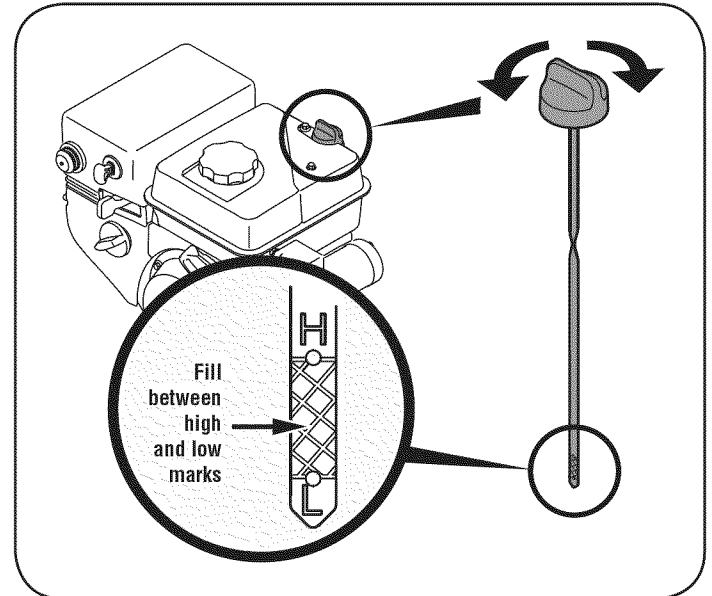

Figure 14

⚠ CAUTION

Used oil is a hazardous waste product. Dispose of used oil properly. Do not discard with household waste. Check with your local authorities or Sears Service Center for safe disposal/recycling facilities.

5. Reinstall the drain plug and tighten it securely.

SERVICE AND MAINTENANCE

6. Refill with the recommended oil and check the oil level. See Recommended Oil Usage chart. The engine's oil capacity is 20 ounces.

	Synthetic 0W-30				
	5W-30				
(°F)	-40°	-20°	0°	20°	40°
(°C)	-30°	-20°	-10°	0°	

CAUTION

DO NOT use nondetergent oil or 2-stroke engine oil. It could shorten the engine's service life.

7. Reinstall the oil filler cap/dipstick securely.

CAUTION

Thoroughly wash your hands with soap and water as soon as possible after handling used oil.

Checking Spark Plug

WARNING

DO NOT check for spark with spark plug removed. DO NOT crank engine with spark plug removed.

WARNING

If the engine has been running, the muffler will be very hot. Be careful not to touch the muffler.

NOTE: Check the spark plug once a season or every 25 hours of operation. Change the spark plug once a season or every 100 hours. To ensure proper engine operation, the spark plug must be properly gapped and free of deposits.

1. Remove the spark plug boot and use a spark plug wrench to remove the plug. See Figure 16.
2. Visually inspect the spark plug. Discard the spark plug if there is apparent wear, or if the insulator is cracked or chipped. Clean the spark plug with a wire brush if it is to be reused.
3. Measure the plug gap with a feeler gauge. Correct as necessary by bending side electrode. See Figure 17. The gap should be set to .02-.03 inches (0.60-0.80 mm).
4. Check that the spark plug washer is in good condition and thread the spark plug in by hand to prevent cross-threading.
5. After the spark plug is seated, tighten with a spark plug wrench to compress the washer.

NOTE: When installing a new spark plug, tighten 1/2-turn after the spark plug seats to compress the washer. When reinstalling a used spark plug, tighten 1/8- to 1/4-turn after the spark plug seats to compress the washer.

CAUTION

The spark plug must be tightened securely. A loose spark plug can become very hot and can damage the engine.

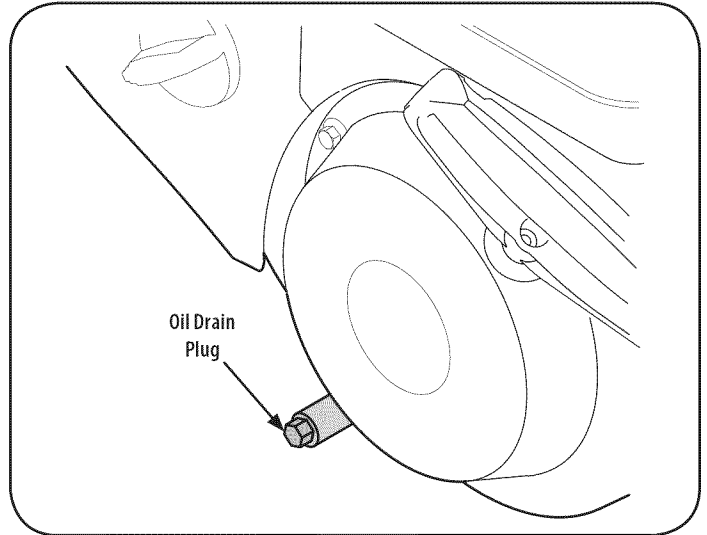

Figure 15

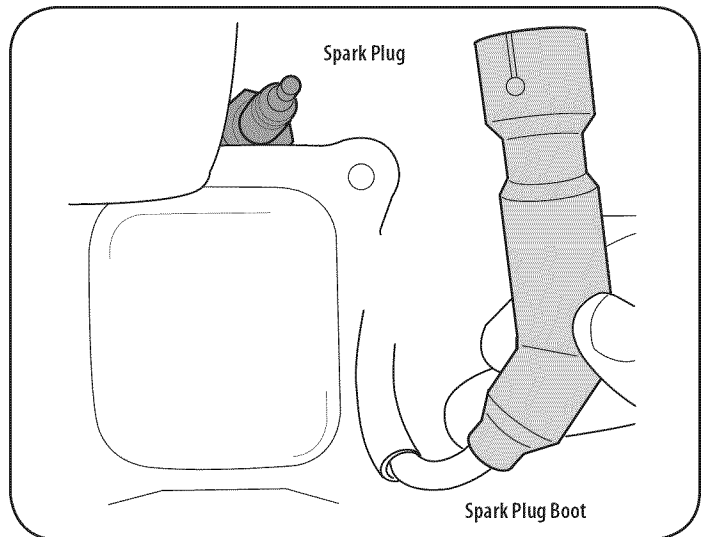

Figure 16

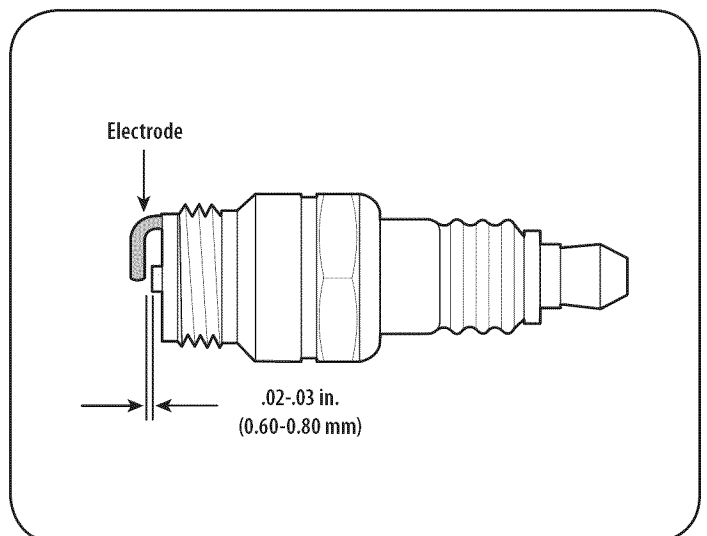

Figure 17

SERVICE AND MAINTENANCE

Lubrication

Gear Shaft

The gear (hex) shaft should be lubricated at least once a season or after every 25 hours of operation.

1. To prevent spillage, remove all fuel from tank by running engine until it stops.
2. Carefully pivot the snow thrower up and forward so that it rests on the auger housing.
3. Remove the lower frame cover from the underside of the snow thrower by removing the self-tapping screws which secure it.
4. Apply a light coating of engine oil (or 3-in-1 oil) to the hex shaft. See Figure 18.

NOTE: When lubricating the hex shaft, be careful not to get any oil on the aluminum drive plate or rubber friction wheel. Doing so will hinder the snow thrower's drive system. Wipe off any excess or spilled oil.

Wheels

At least once a season, remove both wheels. Clean and coat the axles with a multipurpose automotive grease before reinstalling wheels.

Auger Shaft

At least once a season, remove the shear pins on auger shaft. Spray lubricant inside shaft, and around the spacers and flange bearings found at either end of the shaft. See Figure 19.

Shave Plate and Skid Shoes

The shave plate and skid shoes on the bottom of the snow thrower are subject to wear. They should be checked periodically and replaced when necessary.

NOTE: The skid shoes on this machine have two wear edges. When one side wears out, they can be rotated 180° to use the other edge.

To remove skid shoes:

1. Remove the two carriage bolts, washers, and hex flange nuts that secure each skid shoe to the snow thrower.
2. Reassemble new skid shoes with the four carriage bolts (two on each side), washers, and hex flange nuts. Refer to Figure 20.

To remove shave plate:

1. Remove the carriage bolts and hex nuts which attach it to the snow thrower housing.
2. Reassemble new shave plate, making sure heads of carriage bolts are to the inside of housing. Tighten securely. See Figure 20.

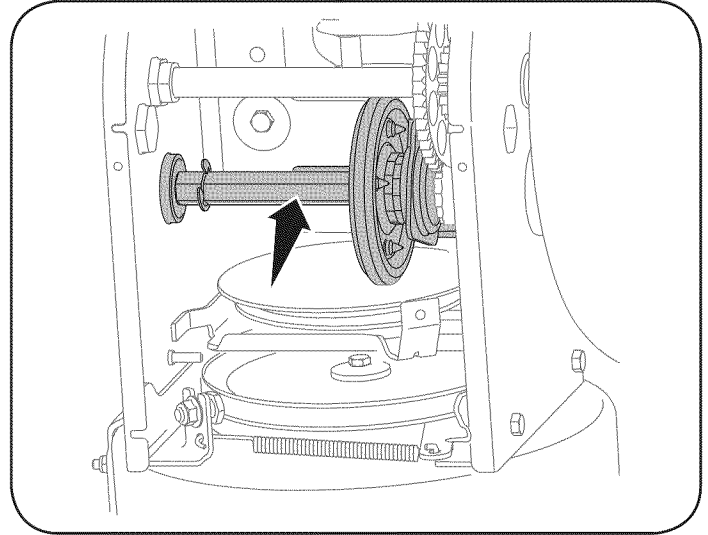

Figure 18

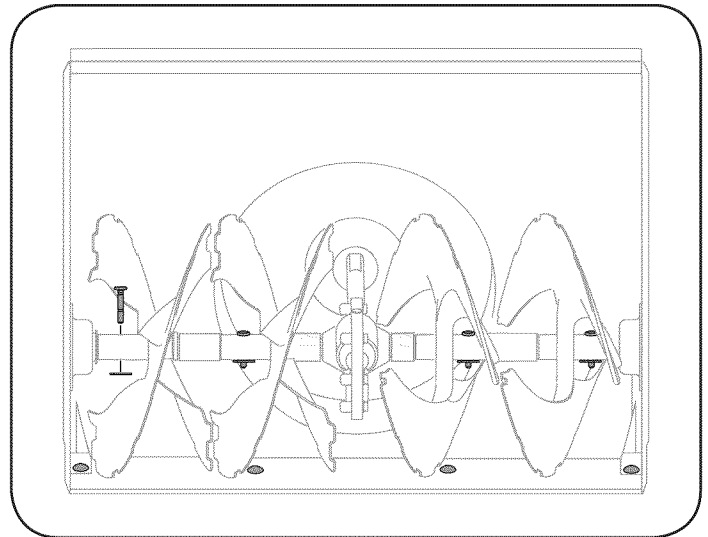

Figure 19

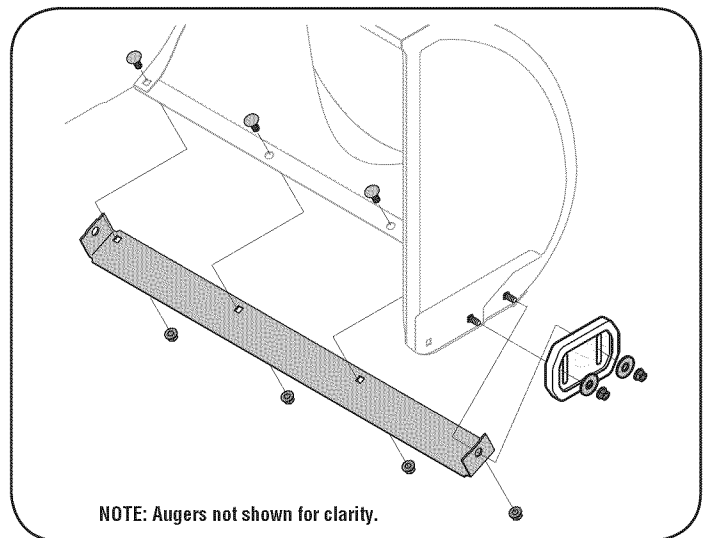

Figure 20

SERVICE AND MAINTENANCE

Adjustments

Shift Cable

If the full range of speeds (forward and reverse) cannot be achieved, refer to the figure to the right and adjust the shift cable as follows:

1. Place the shift lever in the fastest forward speed position (F6).
2. Loosen the hex nut on the shift cable index bracket. See Figure 21.
3. Pivot the bracket downward to take up slack in the cable.
4. Retighten the hex nut.

Drive Control

When the drive control is released and in the disengaged “up” position, the cable should have very little slack. It should NOT be tight. Also, if there is excessive slack in the drive cable or if the unit experiences intermittent drive while using, the cable may need to be adjusted. Check the adjustment of the drive control as follows:

1. With the drive control released, push the snow thrower gently forward. The unit should roll freely.
2. Engage the drive control and gently attempt to push the snow thrower forward. The wheels should not turn. The unit should not roll freely.
3. With the drive control released, move the shift lever back and forth between the R2 position and the F6 position several times. There should be no resistance in the shift lever.
4. If any of the above tests failed, the drive cable is in need of adjustment. Proceed as follows:
 - a. Shut off the engine as instructed in the Operation section.
 - b. Loosen the lower hex bolt on the drive cable bracket. See Figure 22.
 - c. Position the bracket upward to provide more slack (or downward to increase cable tension).
 - d. Retighten the lower hex bolt.

Chute

If the chute fails to remain stationary during operation, the pre-load of the chute can be adjusted by tightening the hex nut found on the front of the chute control head.

1. To increase the preload, tighten the hex nut clockwise in $\frac{1}{4}$ turn intervals. See Figure 23.
2. If the chute directional control is difficult to crank, decrease the preload by loosening the hex nut counterclockwise in $\frac{1}{4}$ turn intervals.

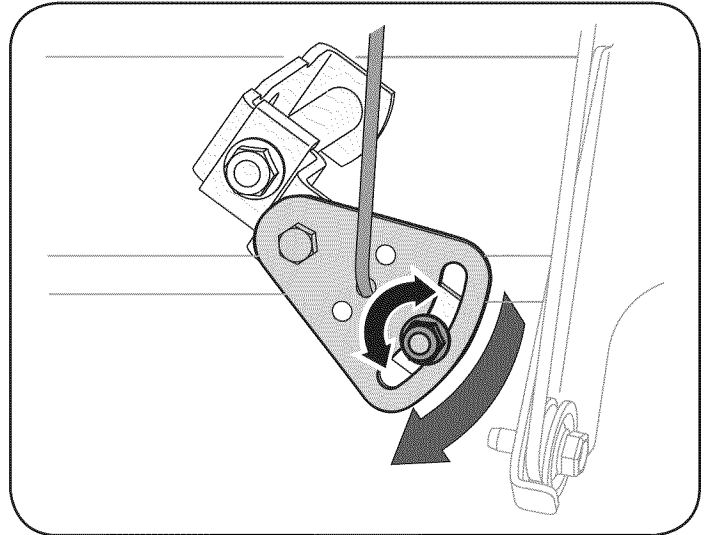

Figure 21

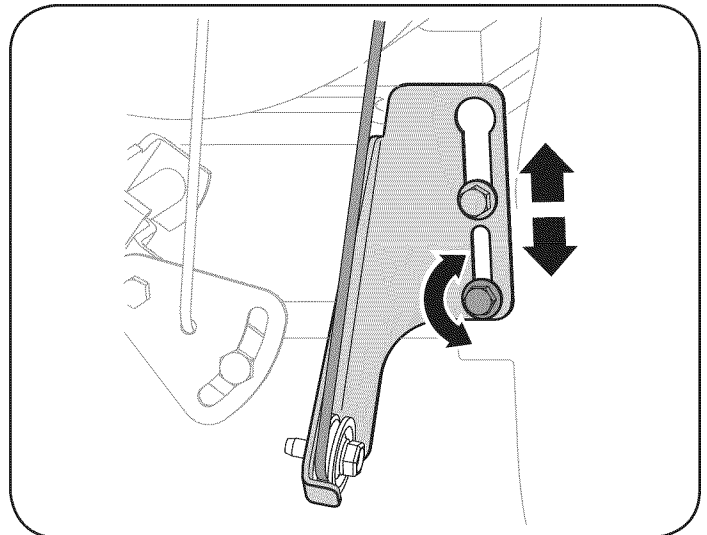

Figure 22

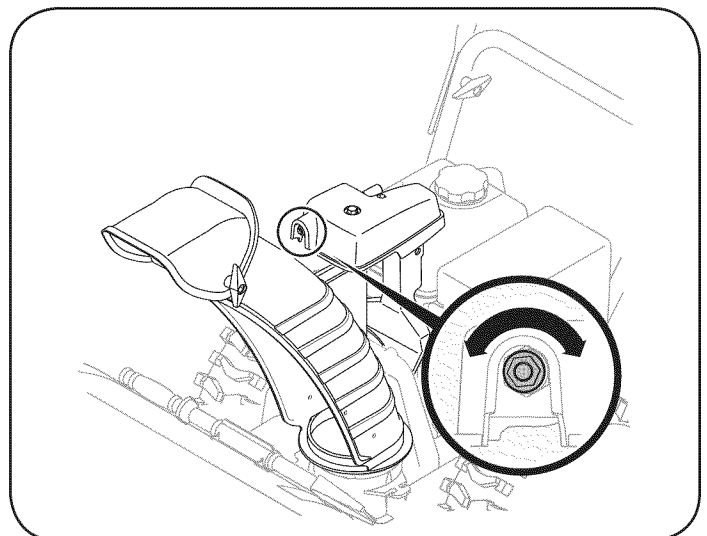

Figure 23

SERVICE AND MAINTENANCE

Auger Control

Refer to the Assembly section for instructions on adjusting the auger control cable.

Skid Shoes

Refer to the Assembly section for instructions on adjusting the skid shoes.

Belt Replacement

Auger Belt

To remove and replace your snow thrower's auger belt, proceed as follows:

1. To prevent spillage, remove all fuel from tank by running engine until it stops.
2. Remove the plastic belt cover on the front of the engine by removing the two self-tapping screws. See Figure 24.
3. Roll the auger belt off the engine pulley. See Figure 25.
4. Carefully pivot the snow thrower up and forward so that it rests on the auger housing.
5. Remove the frame cover from the underside of the snow thrower by removing four self-tapping screws which secure it. See Figure 26.

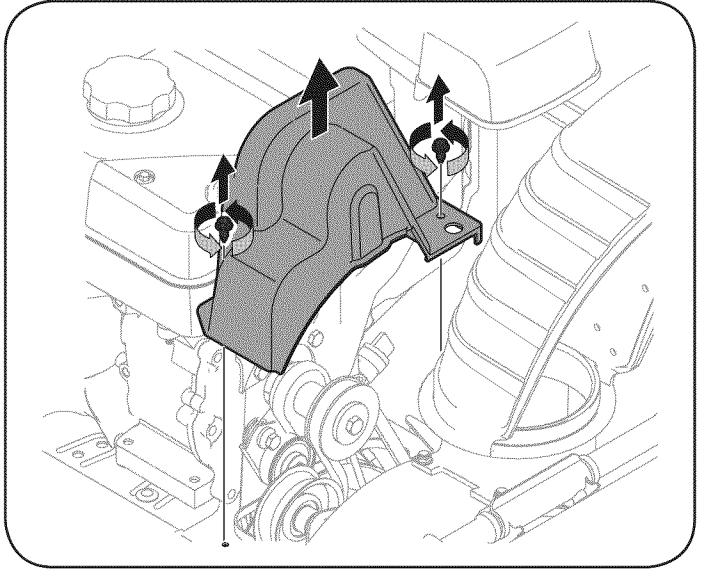

Figure 24

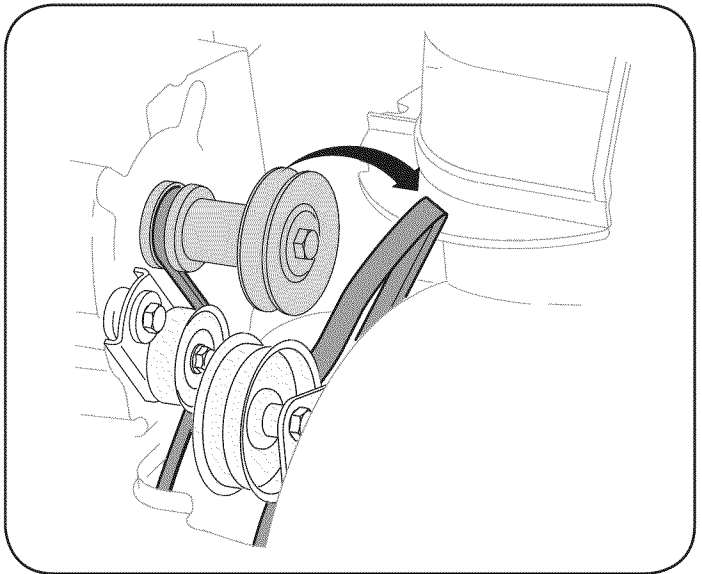

Figure 25

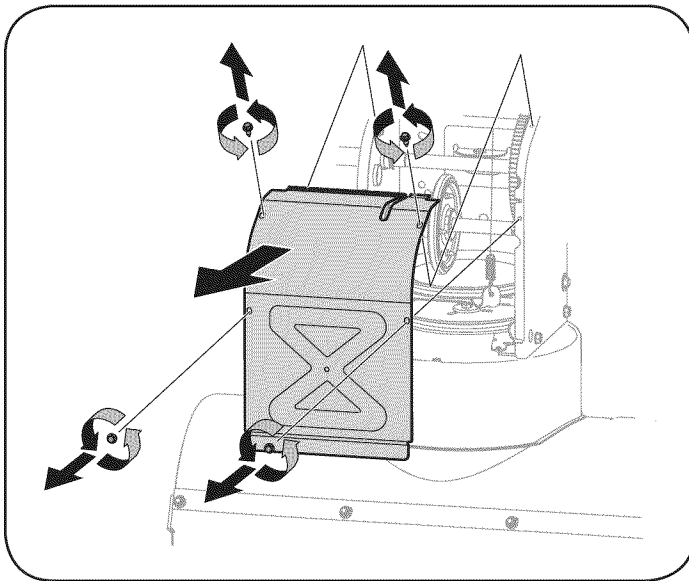

Figure 26

SERVICE AND MAINTENANCE

- Loosen and remove the shoulder screw which acts as a belt keeper. Refer to Figure 27.
- Remove the belt from around the auger pulley, and slip the belt between the support bracket and the auger pulley. See Figure 28.
NOTE: Engaging the auger control will ease removal and reinstallation of the belt.
- Reassemble auger belt by following instructions in reverse order.
NOTE: Do NOT forget to reinstall the shoulder screw and reconnect the spring to the frame after installing a replacement auger belt.
- Perform the Auger Control test outlined in the Assembly section of this manual.

Drive Belt

NOTE: Several components must be removed and special tools are required in order to replace the snow thrower's drive belt. Contact the nearest Sears Parts & Repair Center to have the drive belt replaced.

Friction Wheel Removal

If the snow thrower fails to drive with the drive control engaged, and performing the drive control cable adjustment fails to correct the problem, the friction wheel may need to be replaced. Follow the instructions below. Examine the friction wheel rubber for signs of wear or cracking and replace wheel if necessary.

- To prevent spillage, remove all fuel from tank by running engine until it stops.
- Place the shift lever in first Forward (F1) position.
- Carefully pivot the snow thrower up and forward so that it rests on the auger housing.
- Remove the frame cover from the underside of the snow thrower by removing the self-tapping screws which secure it.
- Remove the right-hand wheel by removing the screw and bell washer which secure it to the axle. See Figure 29.

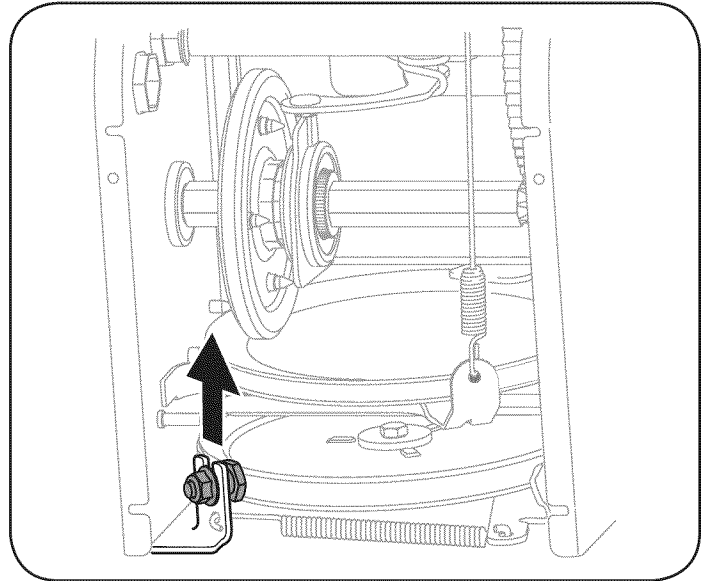

Figure 27

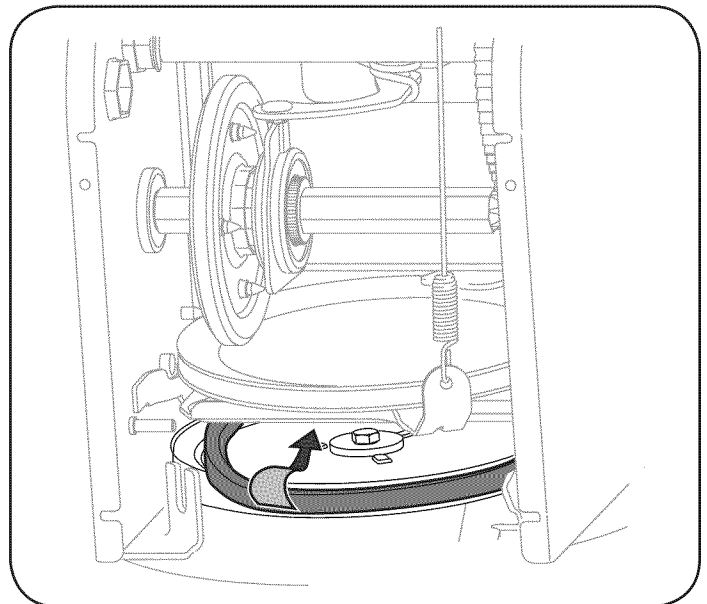

Figure 28

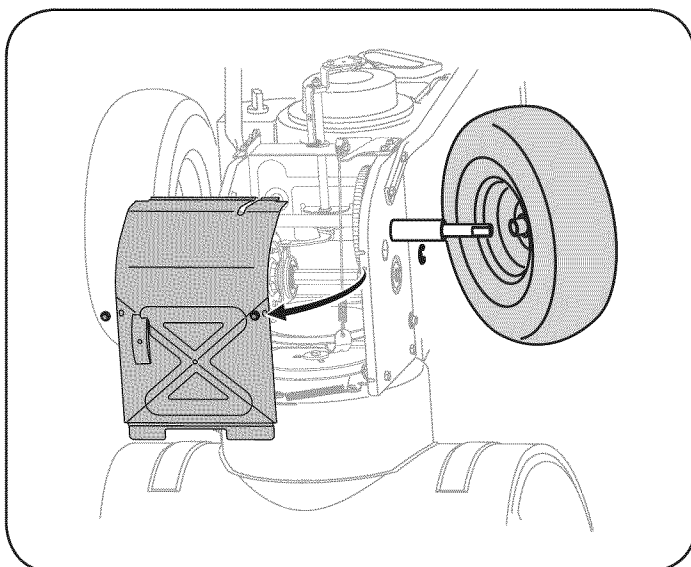

Figure 29

SERVICE AND MAINTENANCE

6. Carefully remove the hex nut and washer which secures the hex shaft to the snow thrower frame and lightly tap the shaft's end to dislodge the ball bearing from the right side of the frame. See Figure 30.

NOTE: Be careful not to damage the threads on the shaft.

7. Carefully position the hex shaft downward and to the left before carefully sliding the friction wheel assembly off the shaft. See Figure 31.

NOTE: If you're replacing the friction wheel assembly as a whole, discard the worn part and slide the new part onto the hex shaft.

8. Follow the steps above in reverse order to reassemble components.
9. Perform the test previously described in the Drive Control section.

If you're disassembling the friction wheel and replacing only the rubber ring, proceed as follows:

NOTE: Not all friction wheels are serviceable. If this is the case, simply replace the friction wheel assembly.

1. Remove the four screws which secure the friction wheel's side plates together. See Figure 32.
2. Remove the rubber ring from between the plates.
3. Reassemble the side plates with a new rubber ring.

NOTE: When reassembling the friction wheel assembly, make sure that the rubber ring is centered and seated properly between the side plates. Tighten each screw only one rotation before turning the wheel clockwise and proceeding with the next screw. Repeat this process several times to ensure the plates are secured with equal force (between 6 ft-lbs and 9 ft-lbs).

4. Slide the friction wheel assembly back onto the hex shaft and follow the steps above in reverse order to reassemble components.
5. Perform the test previously described in the Drive Control section.

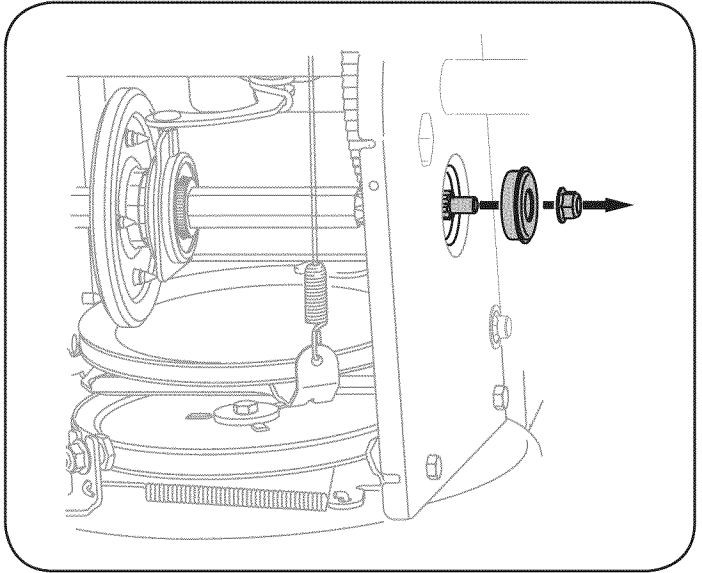

Figure 30

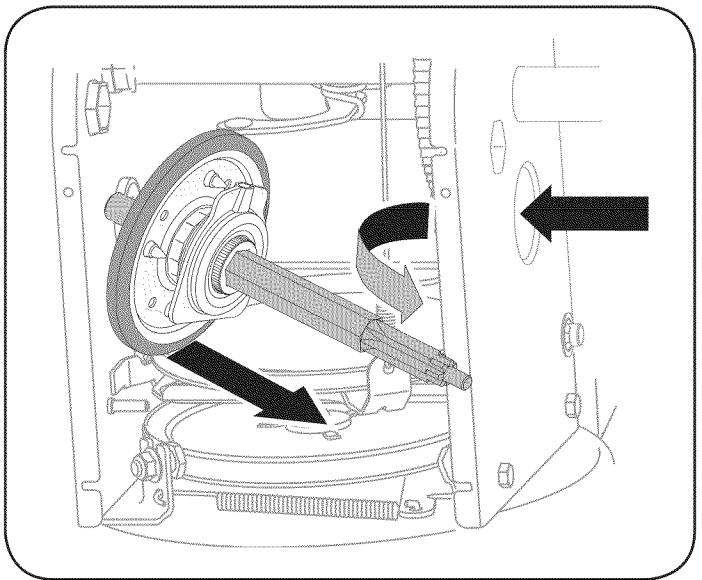

Figure 31

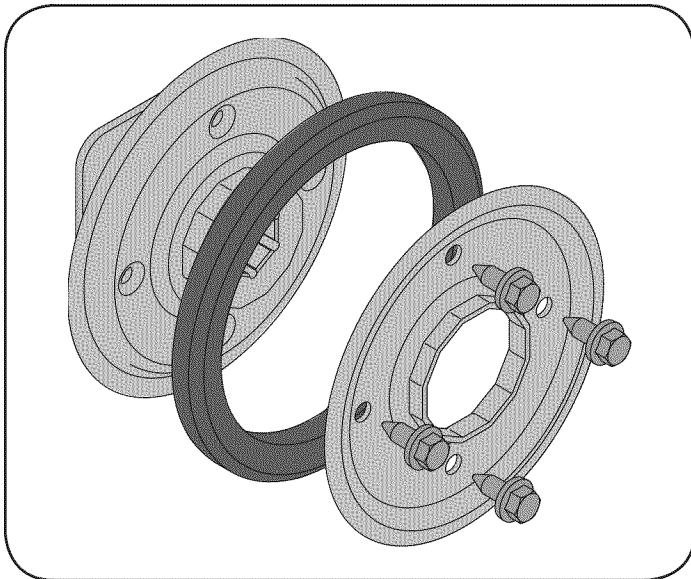

Figure 32

OFF-SEASON STORAGE

If the snow thrower will not be used for 30 days or longer, or if it is the end of the snow season when the last possibility of snow is gone, the equipment needs to be stored properly. Follow storage instructions below to ensure top performance from the snow thrower for many more years.

Preparing Engine

Engines stored over 30 days need to be drained of fuel to prevent deterioration and gum from forming in fuel system or on essential carburetor parts. If the gasoline in your engine deteriorates during storage, you may need to have the carburetor, and other fuel system components, serviced or replaced.

1. Remove all fuel from tank by running engine until it stops. Do not attempt to pour fuel from the engine.
 2. Change the engine oil.
 3. Remove spark plug and pour approximately 1 oz. (30 ml) of clean engine oil into the cylinder. Pull the recoil starter several times to distribute the oil, and reinstall the spark plug.
 4. Clean debris from around engine, and under, around, and behind muffler. Apply a light film of oil on any areas that are susceptible to rust.
- Store in a clean, dry and well ventilated area away from any appliance that operates with a flame or pilot light, such as a furnace, water heater, or clothes dryer. Avoid any area with a spark producing electric motor, or where power tools are operated.

WARNING

Never store snow thrower with fuel in tank indoors or in poorly ventilated areas, where fuel fumes may reach an open flame, spark or pilot light as on a furnace, water heater, clothes dryer or gas appliance.

- If possible, avoid storage areas with high humidity.
- Keep the engine level in storage. Tilting can cause fuel or oil leakage.

Preparing Snow Thrower

- When storing the snow thrower in an unventilated or metal storage shed, care should be taken to rustproof the equipment. Using a light oil or silicone, coat the equipment, especially any chains, springs, bearings and cables.
- Remove all dirt from exterior of engine and equipment.
- Follow lubrication recommendations.
- Store equipment in a clean, dry area.
- Inflate the tires to the maximum PSI. Refer to tire sidewall.

TROUBLESHOOTING

WARNING

Disconnect the spark plug wire and ground it against the engine to prevent unintended starting. Before performing any type of maintenance/service, disengage all controls and stop the engine. Wait until all moving parts have come to a complete stop. Always wear safety glasses during operation or while performing any adjustments or repairs.

This section addresses minor service issues. To locate the nearest Sears Service Center or to schedule service, simply contact Sears at 1-800-4-MY-HOME®.

Problem	Cause	Remedy
Engine fails to start	<ol style="list-style-type: none"> 1. Choke control not in CHOKE position. 2. Spark plug wire disconnected. 3. Faulty spark plug. 4. Fuel tank empty or stale fuel. 5. Engine not primed. 6. Key not inserted. 7. Extension cord not connected (when using electric start button, on models so equipped). 	<ol style="list-style-type: none"> 1. Move choke control to CHOKE position. 2. Connect wire to spark plug. 3. Clean, adjust gap, or replace. 4. Fill tank with clean, fresh gasoline. 5. Prime engine as instructed in the Operation Section. 6. Insert key fully into the switch. 7. Connect one end of the extension cord to the electric starter outlet and the other end to a three-prong 120-volt, grounded, AC outlet.
Engine running erratically/inconsistent RPM (hunting or surging)	<ol style="list-style-type: none"> 1. Engine running on CHOKE. 2. Stale fuel. 3. Water or dirt in fuel system. 4. Carburetor out of adjustment. 5. Over-governed engine. 	<ol style="list-style-type: none"> 1. Move choke control to RUN position. 2. Fill tank with clean, fresh gasoline. 3. Drain fuel tank by running engine until it stops. Refill with fresh fuel. 4. Contact your Sears Parts & Repair Center. 5. Contact your Sears Parts & Repair Center.
Excessive vibration	<ol style="list-style-type: none"> 1. Loose parts or damaged auger. 	<ol style="list-style-type: none"> 1. Stop engine immediately and disconnect spark plug wire. Tighten all bolts and nuts. If vibration continues, have unit serviced by a Sears Parts & Repair Center.
Loss of power	<ol style="list-style-type: none"> 1. Spark plug wire loose. 2. Gas cap vent hole plugged. 	<ol style="list-style-type: none"> 1. Connect and tighten spark plug wire. 2. Remove ice and snow from gas cap. Be certain vent hole is clear.
Unit fails to propel itself	<ol style="list-style-type: none"> 1. Drive cable in need of adjustment. 2. Drive belt loose or damaged. 3. Worn friction wheel. 	<ol style="list-style-type: none"> 1. Adjust drive control cable. Refer to Service and Maintenance section. 2. Have drive belt replaced. Contact your Sears Parts & Repair Center. 3. Have friction wheel replaced at a Sears Parts & Repair Center.

NEED MORE HELP?

You'll find the answer and more on managemylife.com – for free!

- Find this and all your other product manuals online.
- Get answers from our team of home experts.
- Get a personalized maintenance plan for your home.
- Find information and tools to help with home projects.



brought to you by Sears

TROUBLESHOOTING

Problem	Cause	Remedy
Unit fails to discharge snow	<ol style="list-style-type: none"> 1. Chute assembly clogged. 2. Foreign object lodged in auger. 3. Auger cable in need of adjustment. 4. Auger belt loose or damaged. 5. Shear pin(s) sheared. 	<ol style="list-style-type: none"> 1. Stop engine immediately and disconnect spark plug wire. Clean chute assembly and inside of auger housing with clean-out tool or a stick. 2. Stop engine immediately and disconnect spark plug wire. Remove object from auger with clean-out tool or a stick. 3. Adjust auger control cable. Refer to Assembly section. 4. Replace auger belt. Refer to Service and Maintenance section. 5. Replace with new shear pin(s).
Chute fails to easily rotate 180 degrees	<ol style="list-style-type: none"> 1. Chute assembled incorrectly. 	<ol style="list-style-type: none"> 1. Disassemble chute control and reassemble as directed in the Assembly section.

NEED MORE HELP?

You'll find the answer and more on managemylife.com -- for free!

- Find this and all your other product manuals online.
- Get answers from our team of home experts.
- Get a personalized maintenance plan for your home.
- Find information and tools to help with home projects.

 **managemylife**

brought to you by Sears

PARTS LIST

Craftsman Snow Thrower Model 247.881731

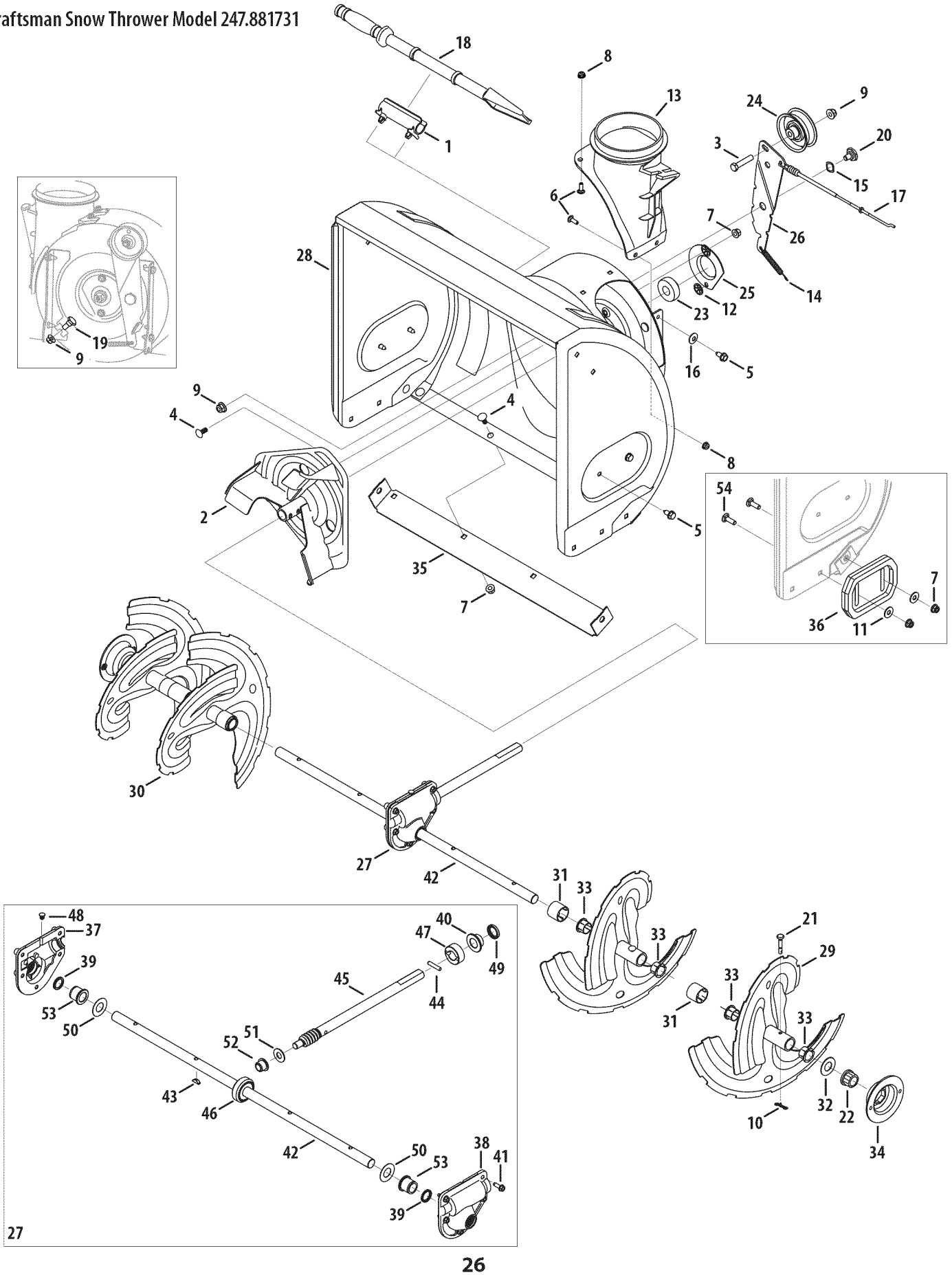

PARTS LIST

Craftsman Snow Thrower Model 247.881731

Ref. No.	Part No.	Description
1.	731-2635	Snow Removal Tool Mount
2.	684-04057A-0637	Impeller Assembly, 12" Dia.
3.	710-0347	Hex Screw, 3/8-16, 1.75, Gr5
4.	710-0451	Bolt, Carriage, 5/16-18, .750 Gr1
5.	710-04484	Screw, 5/16-18, 0.750
6.	710-0703	Screw, Carriage, 1/4-20, .750, Gr5
7.	712-04063	Nut, Flange Lock, 5/16-18, Nylon
8.	712-04064	Nut, Flange Lock, 1/4-20, Nylon
9.	712-04065	Nut, Flange Lock, 3/8-16, Nylon
10.	714-04040	Cotter Pin, Bow-tie
11.	936-0159	Washer, Flat, .349 x .879 x .063
12.	926-04012	Nut, Push-on, .25 Dia
13.	731-07525	Chute, Adapter 5" Dia
14.	732-04460	Spring, Extension, .38 OD x 4.59
15.	736-0174	Washer, Wave, .625 x .885 x .015
16.	736-0242	Washer, Bell, .340 x .872 x .060
17.	946-04230A	Clutch Cable, Auger, 47.23"
18.	931-2643	Snow Removal Tool
19.	738-0143	Screw, Shoulder, .498 x .34, 3/8-16
20.	938-0281	Screw, Shoulder, .625 x .17, 3/8-16
21.	738-04124A	Shear Pin, .25 x 1.50
22.	941-0245	Bearing, Hex Flange x .75 ID
23.	941-0309	Bearing, Ball, .75 ID x 1.85 OD
24.	756-04224	Flat Pulley, Idler, 2.75 OD
25.	790-00075	Housing, Bearing, 1.85 ID
26.	790-00080A-0637	Bracket, Auger Idler w/ Brake
27.	918-04171B	Gearbox Assembly, Auger, 24"

Ref. No.	Part No.	Description
28.	684-04265-4044	Housing Assembly, Auger 24"
29.	684-04107-0637	Spiral Assembly, LH
30.	684-04108-0637	Spiral Assembly, RH
31.	731-04870	Spacer, 1.25 OD x .75 ID x 1.00
32.	736-0188	Washer, Flat, .76 x 1.49 x .06
33.	741-0493A	Bushing, Flange, .80 ID x .91 OD
34.	790-00087A-0637	Housing, 1" Hex Bearing
35.	790-00120-4044	Shave Plate, 2.25 x 23.66
36.	731-06439	Slide Shoe
37.	918-0123A	Housing, Auger, RH Reduced
38.	918-0124A	Housing, Auger, LH Reduced
39.	921-0338	Seal, Oil, .750 x 1.00 x .125
40.	741-0662	Bearing, Flange, .75 x 1.0 x .59
41.	710-0642	Screw, Self-tapping, 1/4-20, 0.750
42.	711-04285	Axle, Auger, 24"
43.	914-0161	Key, Hi-pro 3/16 x 5/8
44.	715-04021	Pin, Dowel, .25 OD x 1.2
45.	917-04126	Shaft, Worm .75 OD
46.	917-04861	Gear, Worm 20T
47.	718-04071	Collar, Thrust
48.	721-0325	Plug, 1/4 x .437
49.	721-0327	Seal, Oil, .75 x 1 x .131
50.	936-0351	Washer, Flat, .760 ID x 1.5 OD
51.	736-3084	Washer, Flat, .51 x 1.12
52.	741-0663	Bearing, Flange, .75 x 1.0 x .925
53.	741-0661B	Bearing, Flange, .75 x 1.00 x .975
54.	710-0276	Screw, Carriage, 5/16-18 x 1.00

PARTS LIST

Craftsman Snow Thrower Model 247.881731

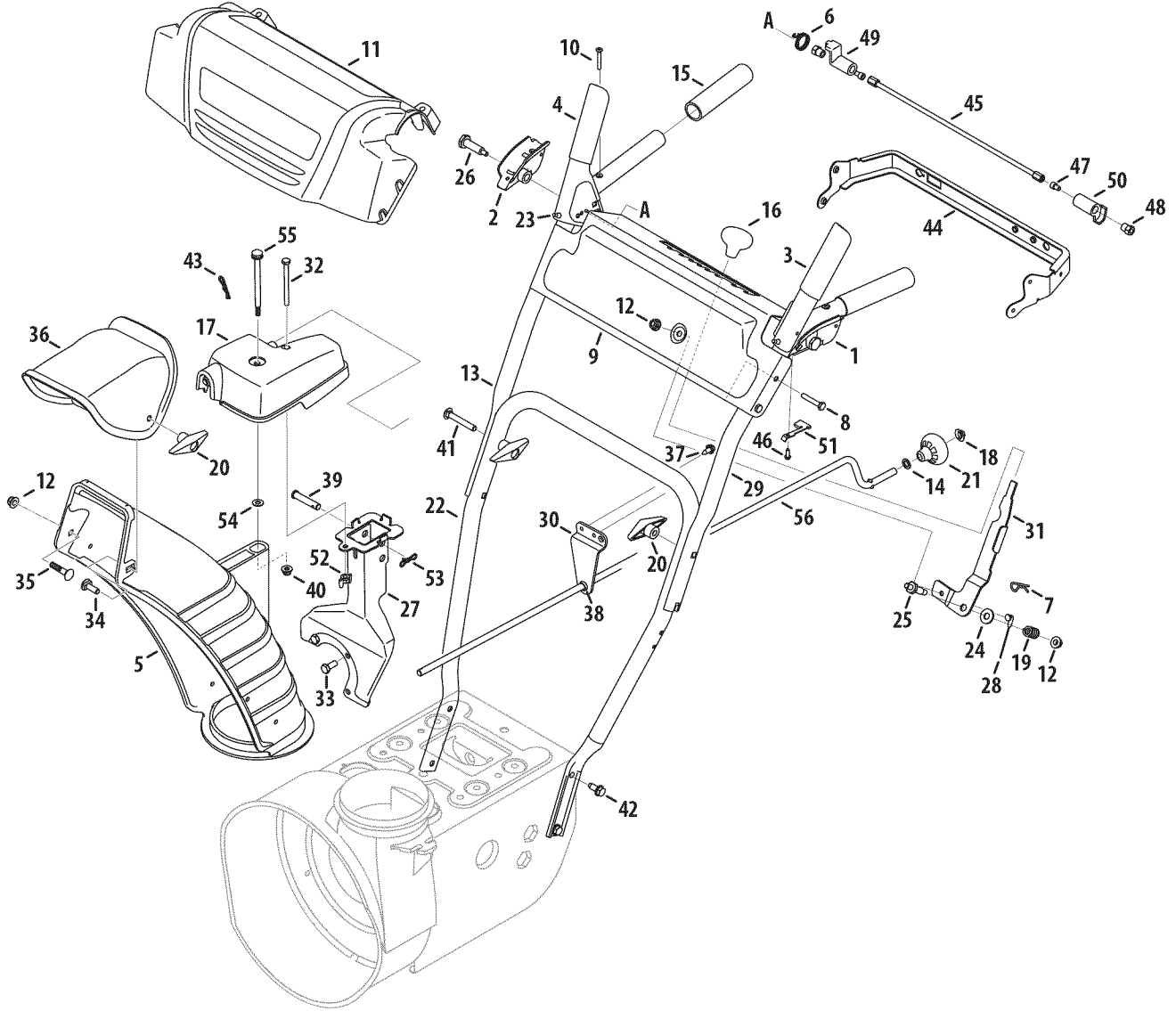

PARTS LIST

Craftsman Snow Thrower Model 247.881731

Ref. No.	Part No.	Description
1.	631-04133A	Handle Assembly, Clutch Lock, LH
2.	631-04134B	Handle Assembly, Clutch Lock, RH
3.	684-04111B	Handle Ass'y, Engage, LH
4.	684-04112C	Handle Ass'y, Engage, RH
5.	731-06440A	Chute, Lower
6.	732-04238	Spring, Torsion, .8156 ID x .3038
7.	914-0145	Click Pin
8.	710-04586	Screw, 1/4-20 x 1.625
9.	790-00219-4044	Panel, Handle, (no cutout)
10.	710-1233	Screw, Machine, #10-24, 1.375
11.	731-06471	Handle Panel Cover
12.	712-04063	Nut, Flange Lock, 5/16-18, Nylon
13.	749-04190A-0637	Handle, Upper, RH
14.	936-0185	Washer, Flat, .375 x .738 x .063
15.	720-0274	Grip, 1.0 ID x 5.0
16.	720-04039	Knob, Shift, Black
17.	918-04933	Gearbox Assembly
18.	926-0100	Cap, Push, 3/8 Rod
19.	732-0193	Spring, .39 x .60 x .88
20.	920-0284	Knob, 5/16-18, Black
21.	720-04102	Crank Knob
22.	749-04138B-0637	Handle, Lower
23.	935-0199A	Bumper, Rubber, .62 OD x .22
24.	736-0262	Washer, Flat, .385 x .870 x .092
25.	738-04118	Bolt, Shoulder, 5/16-18 x 0.905
26.	738-04348	Screw, Shoulder, .43 x 1.3, 1/4-20
27.	684-04311A-0637	Bracket, Chute Support
28.	946-04397A	Cable, Speed Selector
29.	749-04191A-0637	Handle, Upper, LH

Ref. No.	Part No.	Description
30.	790-00341-0637	Bracket, Rod
31.	790-00313-0637	Shift Lever
32.	710-04370	Screw, 1/4-20 x 3.00
33.	710-0627	Screw, 5/16-24 x .750
34.	710-04071	Bolt, Carriage, 5/16-18, 1.0
35.	710-0451	Bolt, Carriage, 5/16-18, .750
36.	731-04426A	Chute, Upper, w/ Label
37.	710-1652	Screw, 1/4-20 x .625
38.	941-0475	Bushing, Plastic, .380
39.	711-04469A	Pin, Clevis
40.	712-04064	Nut, Flange Lock, 1/4-20
41.	710-0572	Screw, Carriage, 5/16-18, 2.25
42.	710-04484	Screw, 5/16-18, 2.25, Gr5
43.	914-0101	Pin, Cotter
44.	790-00248C-0637	Bracket, Panel
45.	684-04250	Rod, Pivot
46.	710-04326	Screw, #8-16 x .50
47.	710-3069	Screw, 1/4-20 x .50
48.	712-04081A	Nut, Hex, 1/4-20
49.	731-04894D	Plate, Lock
50.	731-04896B	Cam, Clutch Lock
51.	732-04219C	Spring, Clutch Lock
52.	712-3087	Nut, Wing
53.	714-04040	Bow-Tie Cotter Pin
54.	736-04446	Washer, Flat, .25 x .630 x .0515
55.	738-04367	Scr. Shldr. Flg., .312 x 3.5 x 1/4-20
56.	747-05386-0637	Crank, Chute
—	753-08018†	Chute Kit (Incl. Ref.# 5 & 36)

† Available for warranty coverage only. Contact a Sears authorized service provider for details.

PARTS LIST

Craftsman Snow Thrower Model 247.881731

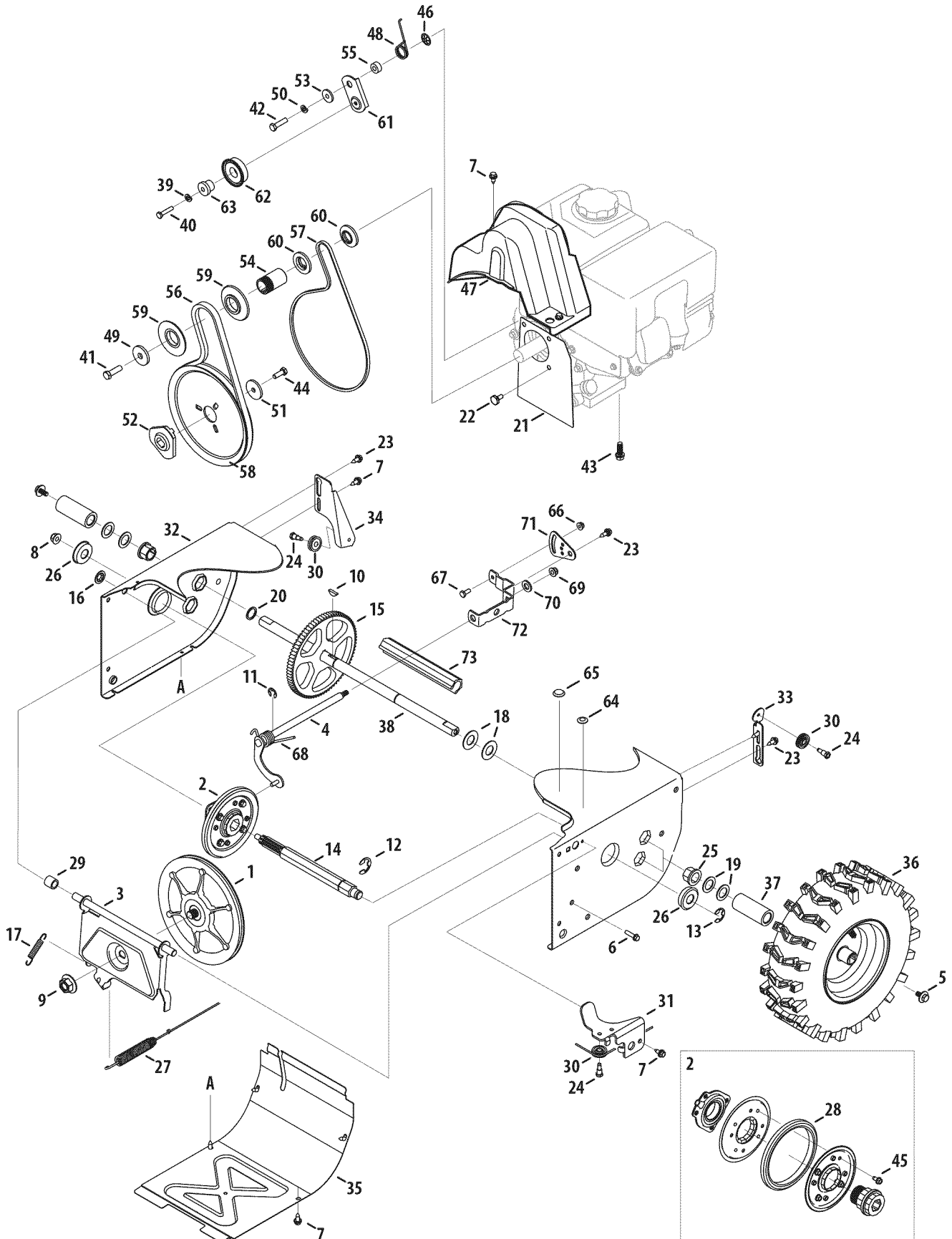

PARTS LIST

Craftsman Snow Thrower Model 247.881731

Ref. No.	Part No.	Description	Ref. No.	Part No.	Description
1.	656-04055	Disc Assembly, Friction Wheel	38.	738-04493	Axle, .75 x 22"
2.	684-04153C	Friction Wheel Assembly, 5.5 OD	39.	936-0329	Washer, Lock, 1/4
3.	684-04154B-0637	Support Bracket, Friction Wheel	40.	710-0809	Hex Screw, 1/4-20, 1.25, Gr5
4.	684-04156A	Shift Assembly, Rod	41.	710-0191	Hex Screw, 3/8-24, 1.25, Gr8
5.	710-05339	Screw, 5/16-24, .750, Gr5	42.	710-0672	Hex Screw, 5/16-24, 1.25, Gr5
6.	710-0788	Screw, 1/4-20, 1.000	43.	710-0654A	Screw, Sems, 3/8-16, 1.00
7.	710-1652	Screw, 1/4-20 x .625	44.	710-1245B	Hex Screw, 5/16-24, .875, Gr8
8.	712-04065	Nut, Flange Lock, 3/8-16, Nylon	45.	710-04484	Screw, 5/16-18 x .750
9.	712-0417A	Nut, Flange, 5/8-18	46.	926-04012	Nut, Push-on, .25 Dia.
10.	914-0126	Key, Hi Pro, 3/16 x 3/4 Dia.	47.	731-05353	Cover, Belt
11.	916-0104	E-ring, .500 Dia.	48.	732-04308A	Spring, Torsion, .850 ID x .354
12.	716-0136	E-ring, Retaining, .875 Dia.	49.	736-3082A	Washer, Flat, .45 x 1.5 x .172
13.	916-0231	E-ring, .750 Dia.	50.	936-0119	Washer, Lock .3125
14.	917-04209A	Hex Shaft, .8125, 7-Tooth	51.	736-0505	Washer, Flat, .34 x 1.50 x .150
15.	917-04230	Gear, 80-Tooth	52.	748-04053A	Pulley, Adapter, .75 Dia.
16.	726-0221	Speed Nut, .500	53.	748-04112B	Spacer, Shoulder, .317 x .50 x .102
17.	932-0264	Extension Spring	54.	750-04303	Spacer, .875 ID x 1.185 OD
18.	736-0188	Washer, Flat, .760 x 1.490 x .060	55.	750-04477A	Spacer, .340 x .750 x .360
19.	936-0287	Washer, Flat, .793 x 1.24 x .060	56.	954-04050	Belt, Auger Drive
20.	736-04161	Washer, Flat, .75 x 1.00 x .060	57.	954-04260	Belt, Wheel Drive
21.	790-00289A-0637	Plate, Cover	58.	756-04109	Pulley, Auger Drive, 8.1 x .5
22.	738-04439	Shoulder Screw	59.	756-04113	Pulley, Half, V x 2.600 OD
23.	738-04184A	Screw, Shoulder, .37 x .105, 1/4-20	60.	756-04252	Pulley, Half, 3/8-V x 1.7160 OD
24.	738-0924A	Screw, 1/4-28, .375	61.	790-00208D	Idler Bracket, Wheel Drive
25.	941-0245	Bearing, Hex Flange x .75 ID	62.	684-04169	Idler Pulley Assembly
26.	941-0563	Bearing, Ball, 17 x 40 x 12	63.	750-04571	Spacer, Shoulder, .26 x .79 x .538
27.	946-05067	Clutch Cable, Wheel, 44.95"	64.	735-04099	Plug, 3/8 ID
28.	935-04054	Rubber, Friction Wheel, 5.5 OD	65.	735-04100	Plug, 1/2 ID
29.	748-0190	Spacer, .508 ID x .75 OD x .68	66.	712-04064	Nut, Flange Lock, 1/4-20, Nylon
30.	756-0625	Roller, Cable	67.	710-0751	Hex Screw, 1/4-20, .620, Gr5
31.	790-00096A-0637	Front Guide Bracket, Auger Cable	68.	732-04311A	Spring, Torsion, .750 ID x .968
32.	790-00180C-4044	Frame	69.	712-04063	Nut, Flange Lock, 5/16-18, Nylon
33.	790-00206A-0637	Guide Bracket, Auger Cable	70.	936-3015	Wash., Flat, .469 x .875 x .105
34.	790-00207C	Guide Bracket, Drive Cable	71.	790-00217A-0637	Pivot Bracket, Speed Selector
35.	790-00316-4044	Cover, Frame	72.	790-00218A-0637	Shift Bracket, Speed Selector
36.	634-04167A-0911	LH Wheel Assembly	73.	731-08181	Spacer, Axle
	634-04168A-0911	RH Wheel Assembly	N/A		Engine (see breakdown)
37.	731-04873	Spacer, 1.25 x .75 x 3.0			MTD Model No. 952Z270-SUA

PARTS LIST

Craftsman Engine Model 270-SUA For Snow Model 247.881731

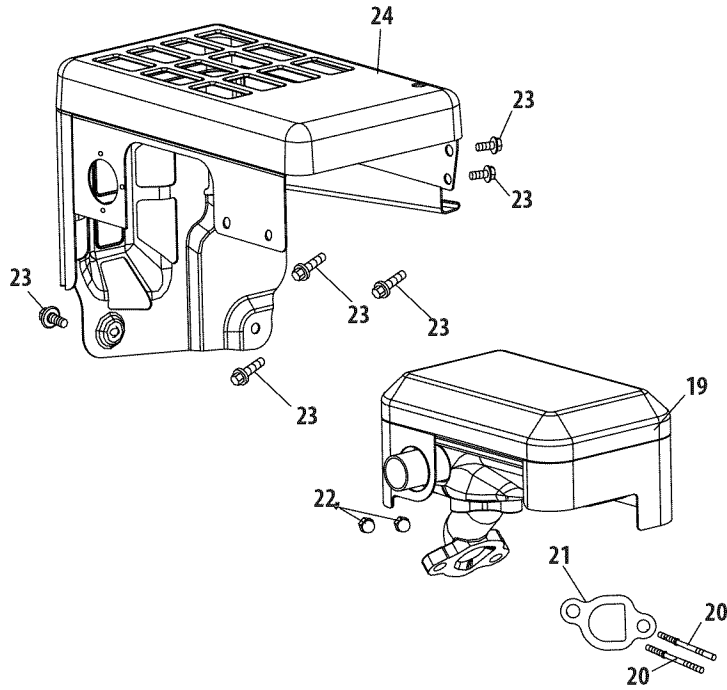

Ref.	Part No.	Description
19	951-11282	Muffler Assembly
20	710-05001	Muffler Stud
20	951-14190	Muffler Stud Kit
21	951-11289	Muffler Gasket
22	712-04214	Nut - M8
23	710-04915	Bolt - M6 X 12 Zin
24	951-10642B	Muffler Shroud

PARTS LIST

Craftsman Engine Model 270-SUA For Snow Model 247.881731

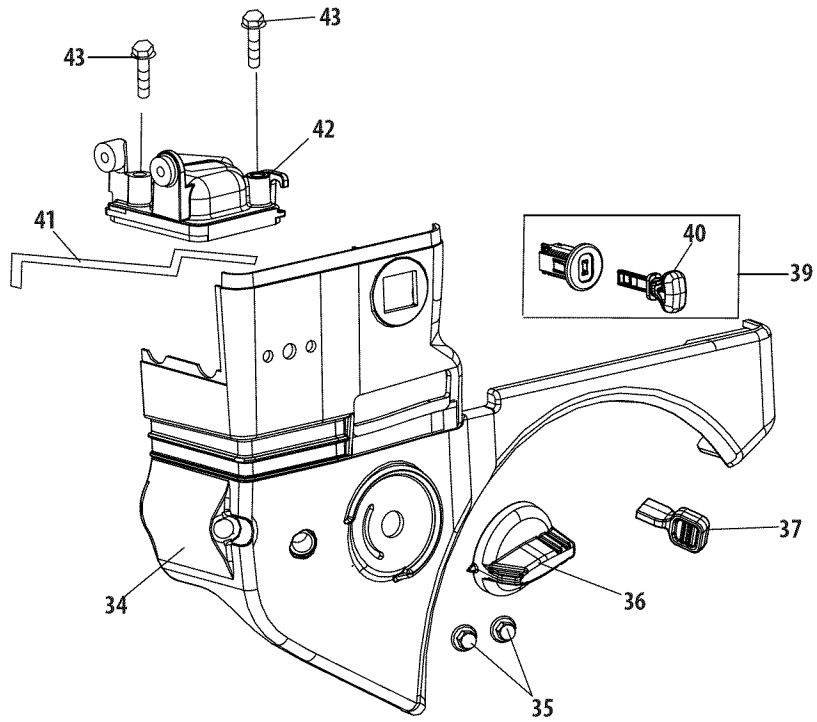

Ref.	Part No.	Description
34	951-10634	Shroud-Engine
35	712-04213	Nut
36	951-11284	Choke Knob
37	951-10757	Throttle Knob
39	951-10637	Switch-Ignition
40	731-05632	Ignition Key Switch
41	951-10640	Push Rod-Choke
42	951-10635	Air Filter Heating
43	710-04943	Bolt-M6 1X28M Spec

PARTS LIST

Craftsman Engine Model 270-SUA For Snow Model 247.881731

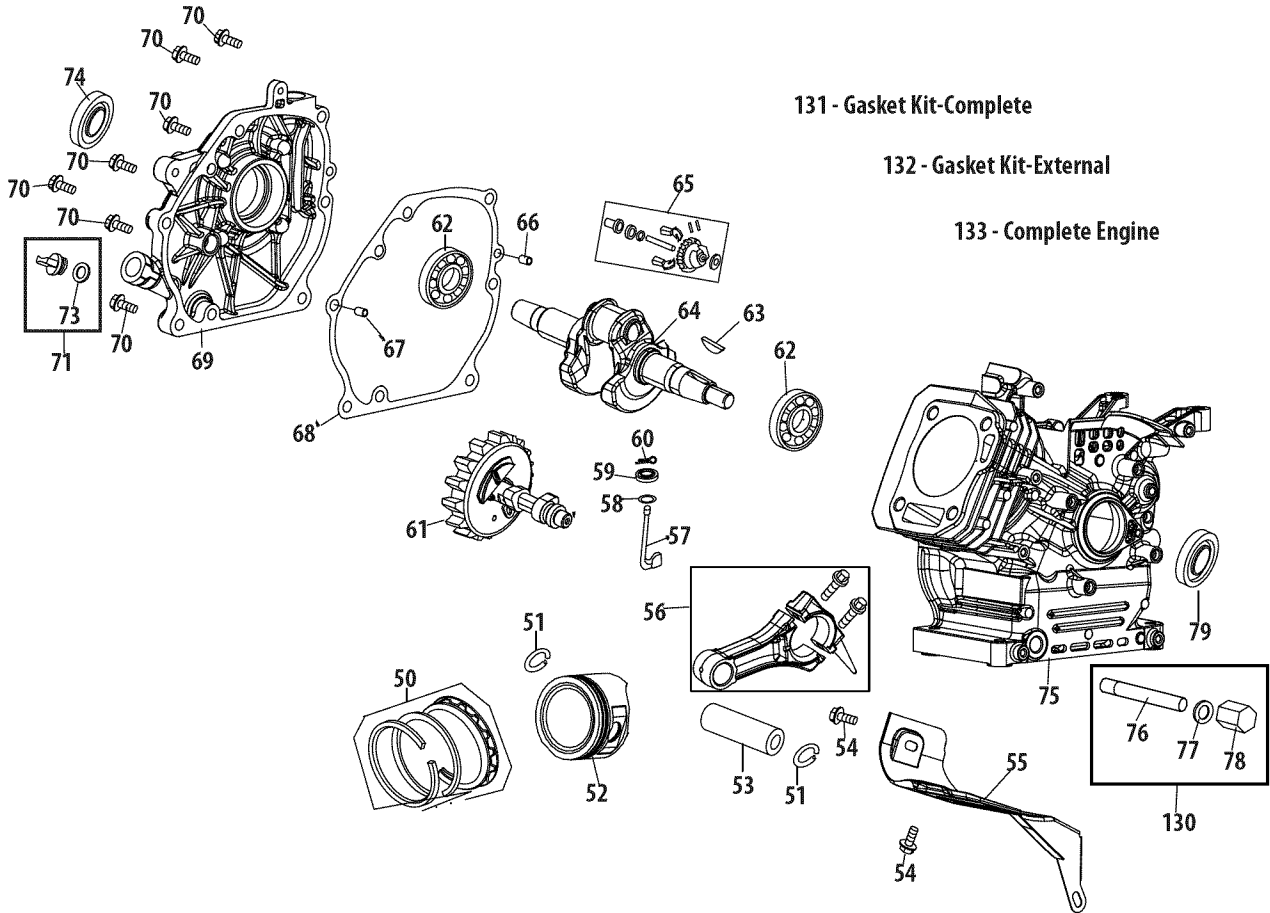

PARTS LIST

Craftsman Engine Model 270-SUA For Snow Model 247.881731

Ref.	Part No.	Description
50	951-12111	Piston Ring Set
51	951-11632	Piston Pin Snap Ring
52	951-12007	Piston
53	951-11633	Piston Pin
54	710-04915	Bolt - M6 X 12 Zin
55	951-11113	Shield - Air
56	951-11573	Connecting Rod Assembly
57	951-14053	Governor Shaft
58	736-04461	Washer
59	951-11902	Governor Seal
60	714-04078	Cotter Pin
61	951-11575	Camshaft Assembly
62	951-11369	Bearing
63	951-10307	Key:Flywheel
64	951-11247A	Crankshaft Kit (Incl. 62,63,64,74,79)
65	951-11576	Governor Gear/Shaft
66	715-04092	Pin-Dowel
67	715-04096	Dowl Pin 9X14
68	951-11371	Crankcase Cover Gasket
69	951-12125	Crankcase Cover
	951-11246	Crankcase Cover Kit (Incl. 62,68-74)
70	710-04932	Bolt
71	951-11283	Oil Fill Plug Assembly
73	951-11577	O-Ring 15.8 X 2.5
74	951-11368	Oil Seal
75	951-11249	Crankcase Kit (Incl. 59,62,74,75,79)
	951-11060B	Shortblock Assembly (Incl. 4,21,27-29,44,46, 47, 50-53,56-79)
76	951-11350	Oil Drain Pipe
77	736-04440	Washer
78	710-04906	Bolt - Drain Plug
79	951-11370	Oil Seal
130	951-10641	Oil Drain Assembly
131	951-11059A	Gasket Kit-Complete (Incl. 4,21,27-29,32,44,58,59,68,74,77,79)
132	951-10661B	Gasket Kit-External (Incl. 4,21,27 29,32,77)
133	952Z270-SUA	Complete Engine

PARTS LIST

Craftsman Engine Model 270-SUA For Snow Model 247.881731

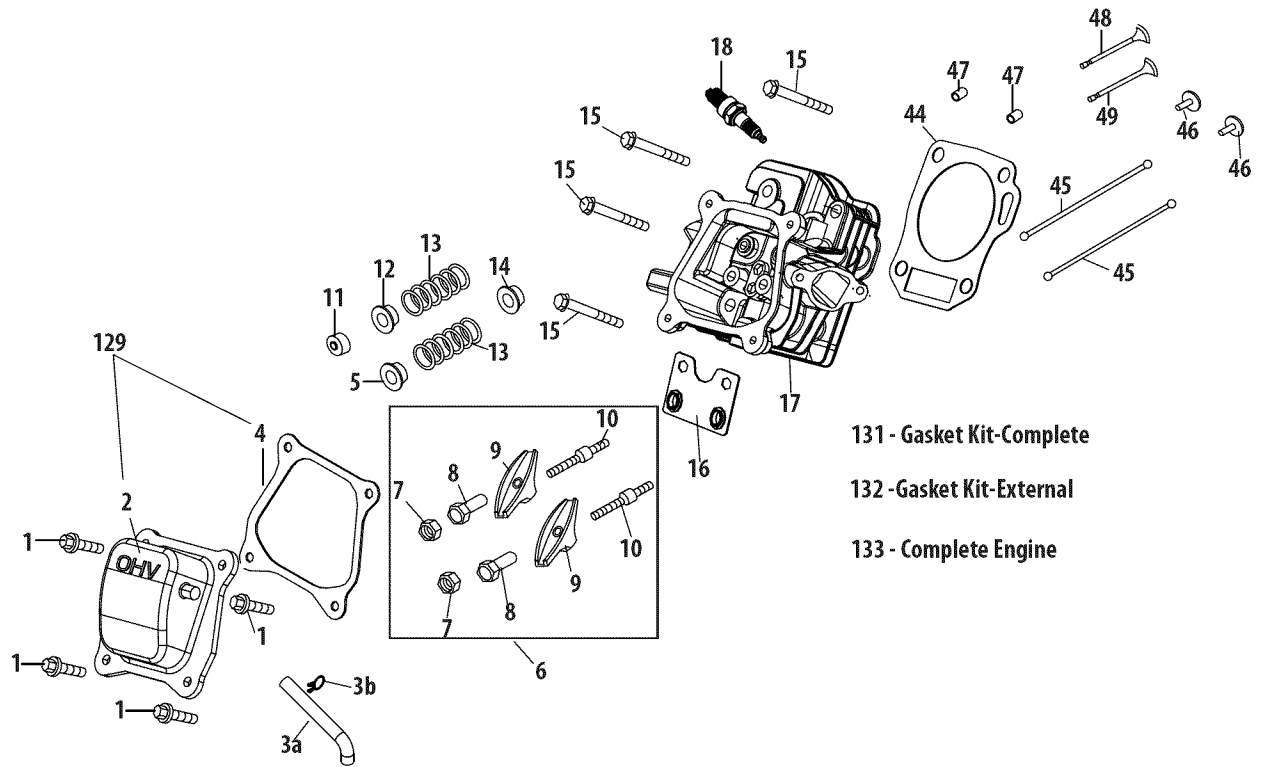

PARTS LIST

Craftsman Engine Model 270-SUA For Snow Model 247.881731

Ref.	Part No.	Description
1	710-04968	Flange Bolt M6
2	951-11054A	Valve Cover
3a	731-07059	Hose-Breather
3b	726-04101	Clamp-Breather Hose
4	951-11565	Valve Cover Gasket
5	951-12000	Intake Valve Spring Retainer
6	951-11892	Rocker Arm Assembly
7	751-11124	Nut - Pivot Lockin
8	751-11123	Nut - Valve Adjust
9	951-11893	Rocker Arm
10	710-04902	Bolt - Pivot
11	951-12002	Exhaust Valve Adjuster
12	951-12003	Exhaust Valve Spring Retainer
13	951-12004	Valve Spring
14	951-11894	Intake Valve Seal
15	710-04933	Bolt - M8 X 55 Zin
16	951-11895	Push Rod Guide
17	951-10722B	Cylinder Head Assembly (Incl. 4-14,16,17,21,27-29, 44,48,49)
18	951-10292	Plug:Spark
44	951-11572	Gasket-Cylinder Head
45	951-10648	Kit-Push Rod
46	951-11899	Tappet
47	715-04108	Pin-Dowl 10 X 16
48	951-10647A	Valve Kit
49	951-10647A	Valve Kit
129	951-12626	Valve Cover Kit
131	951-11059A	Gasket Kit-Complete (Incl. 4,21,27-29,32,44,58,59,68,74,77,79)
132	951-10661B	Gasket Kit-External (Incl. 4,21,27 29,32,77)
133	952Z270-SUA	Complete Engine

PARTS LIST

Craftsman Engine Model 270-SUA For Snow Model 247.881731

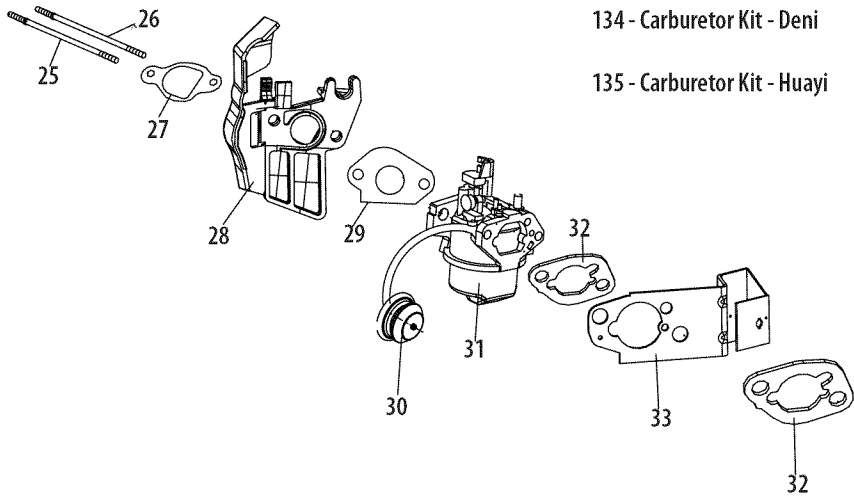

134 - Carburetor Kit - Deni

135 - Carburetor Kit - Huayi

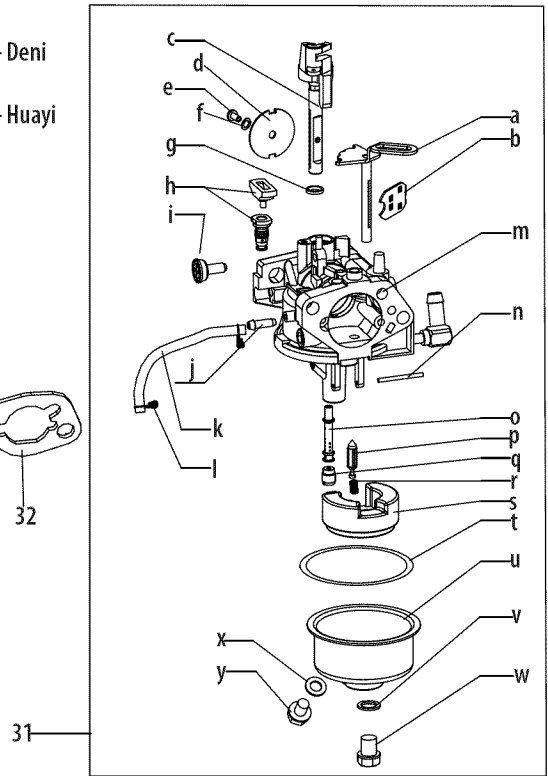

PARTS LIST

Craftsman Engine Model 270-SUA For Snow Model 247.881731

Ref.	Part No.	Description
25	710-04939	Stud-Carb
26	710-04910	Stud - M6 X 105
27	951-11567	Gasket-Carb Insulator
28	951-11896	Carburetor Insulat
29	951-11569A	Carburetor Gasket
30	951-10639A	Primer
30	951-11824	Primer Bulb
31	951-14026A	Carburetor Assembly - Huayi
31	951-14027A	Carburetor Assembly - Deni
32	951-11897	Carburetor Gasket
33	951-11112	Bracket - Choke Control
134	951-14154	Carburetor Kit - Deni (Incl. h,n,o,p,q,r,s,t,u,x)
135	951-12788A	Carburetor Kit - Huayi (Incl. h,n,o,p,q,r,s,t,u,x)
a	n/a	Choke Shaft
b	n/a	Choke Plate
c	n/a	Throttle Shaft
d	n/a	Throttle Plate
e	710-05469	Screw M3x5
f	736-04638	Lock Washer
g	n/a	Gasket, Throttle Plate
h	n/a	Idle Jet Assembly
i	n/a	Idle Speed Adjusting Screw
j	n/a	Mixture Screw
k	951-11699	Primer Hose
l	951-11906	Hose Clamp
m	n/a	Carburetor Body
n	n/a	Float Pin
o	n/a	Emulsion Tube
p	951-12875	Float Needle Valve
q	n/a	Main Jet
r	n/a	Needle Valve Spring
s	n/a	Float
t	951-11589	Fuel Bowl Gasket
u	n/a	Fuel Bowl
v	951-11348	Fuel Bowl Gasket
w	710-04945	Fuel Bowl Mounting Bolt
x	951-11349	Fuel Drain Plug Gasket
y	710-04938	Fuel Drain Plug

PARTS LIST

Craftsman Engine Model 270-SUA For Snow Model 247.881731

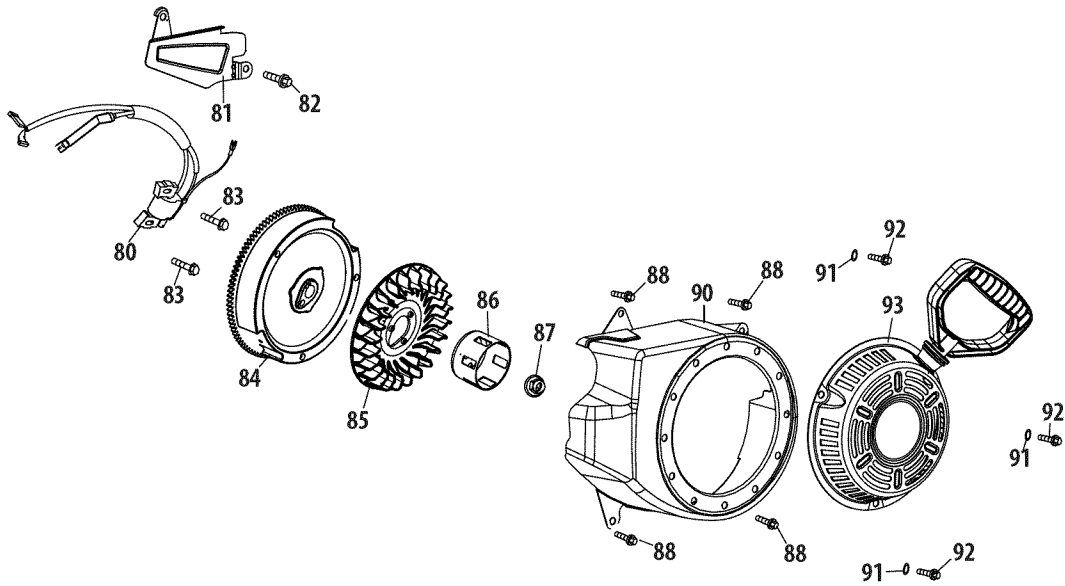

Ref.	Part No.	Description
80	951-10646	Ignition Coil
81	951-11110	Shield - Air Flow
82	710-04940	Bolt
83	710-04919	Bolt - Flange M6
84	951-12416	Flywheel
85	951-10934	Cooling Fan
86	951-10911	Starter Cup
87	712-04209	Nut - M14
88	710-04915	Bolt - M6 X 12 Zin
90	951-10663A	Fan Cover Complete
91	736-04455	Flat Washer-Recoil
92	710-04974	Flange Bolt M6
93	951-14151	Recoil Start Assembly

PARTS LIST

Craftsman Engine Model 270-SUA For Snow Model 247.881731

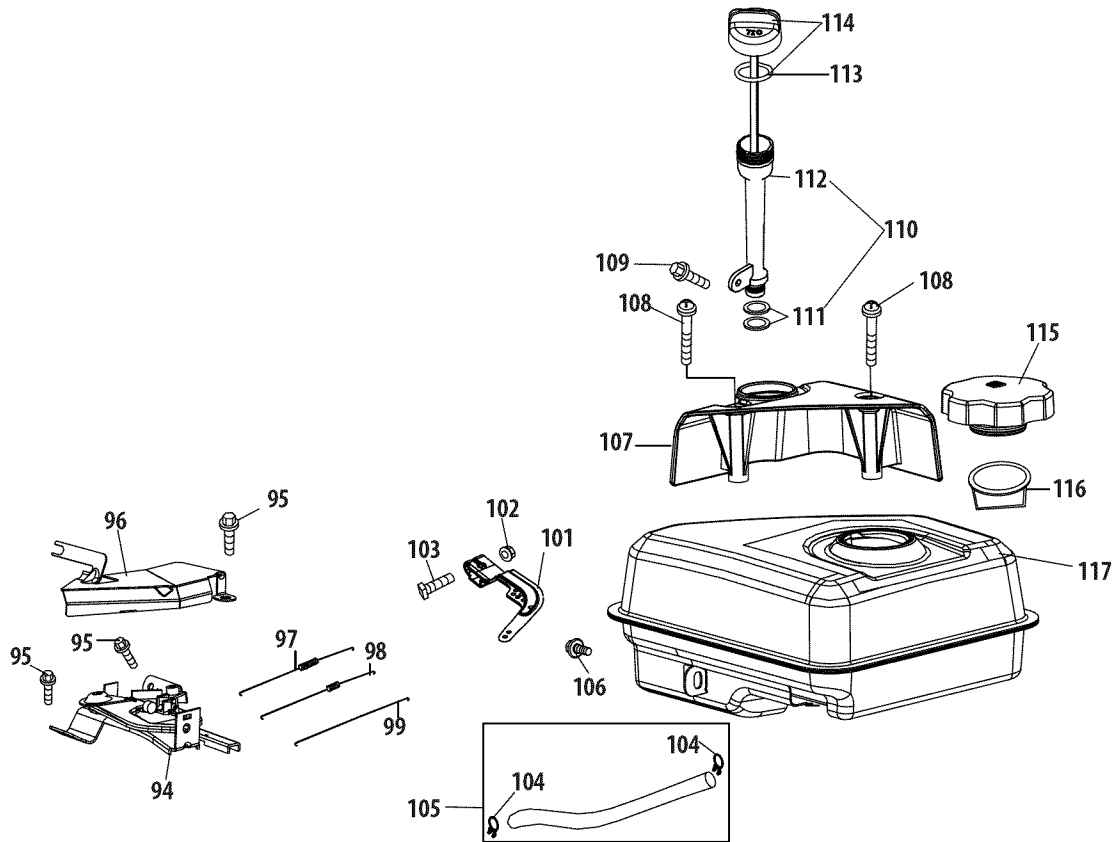

Ref.	Part No.	Description
94	951-10758	Throttle Control Assembly
95	710-05103	Bolt-M6 X 12
96	951-11108	Shield - Governor
97	951-11935	Governor Spring
98	951-10664	Spring-Throttle Return
99	951-10665	Rod-Governor
101	951-11106	Bracket - Governor
102	712-04212	Nut - M6
103	710-04908	Bolt - M6 X 21 Gov
104	951-11700	Hose Clamp-Carb
105	951-10650	Kit-Fuel Line
106	710-04915	Bolt - M6 X 12 Zin

Ref.	Part No.	Description
107	951-11914	Engine/Dipstick Cover
108	710-04905	Bolt
109	710-04915	Bolt - M6 X 12 Zin
110	951-11913	Oil Fill Tube Assembly
111	951-11381	O-Ring
112	951-10656	Dipstick Tube
113	951-11904	O-Ring Dipstick
114	951-12482	Dipstick Assy
115	951-12533	Fuel Cap
116	951-11933	Fuel Level Indicator
117	951-10653B	Fuel Tank

PARTS LIST

Craftsman Engine Model 270-SUA For Snow Model 247.881731

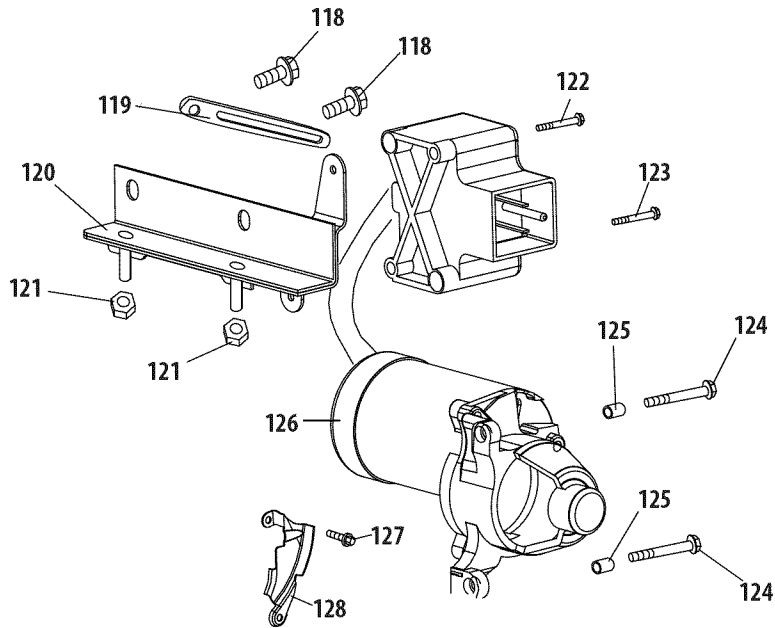

Ref.	Part No.	Description
118	710-04914	Bolt - Flange M6
119	951-11680	Flexible Clamp
120	951-11114	Bracket - Switch Housing Mount
121	712-05015	Nut
122	710-04965	Screw M4 X 55
123	710-04935	Screw - M4 X 60
124	710-05182	Bolt-M6 X 32
125	715-04088	Pin - Dowel
126	951-10645A	Electric Starter
127	710-04915	Bolt - M6 X 12 Zin
128	951-11109	Shield - Blower Housing

PARTS LIST

Craftsman Snow Thrower Model 247.881731

777S32636

CLEAN-OUT TOOL



1. KEEP AWAY FROM ROTATING IMPELLER AND AUGER. CONTACT WITH IMPELLER OR AUGER CAN AMPUTATE HANDS AND FEET.
2. USE CLEAN-OUT TOOL TO UNCLOG DISCHARGE CHUTE.
3. DISENGAGE CLUTCH LEVERS, STOP ENGINE, AND REMAIN BEHIND HANDLES UNTIL ALL MOVING PARTS HAVE STOPPED BEFORE UNBLOCKING OR SERVICING MACHINE.
4. TO AVOID THROWN OBJECTS INJURIES, NEVER DIRECT DISCHARGE AT BYSTANDERS. USE EXTRA CAUTION WHEN OPERATING ON GRAVEL SURFACES.
5. READ OPERATOR'S MANUAL.

DANGER

DANGER



AVOID INJURY FROM ROTATING AUGER - KEEP HANDS, FEET AND CLOTHING AWAY.

777X43688

DO NOT USE E85 OR FUEL CONTAINING MORE THAN 10% ETHANOL TO AVOID ENGINE DAMAGE



777S32236

DANGER



- NEVER PUT HAND IN CHUTE. CONTACT WITH ROTATING PARTS CAN AMPUTATE FINGERS AND HANDS.
- SHUT OFF ENGINE AND WAIT UNTIL ALL MOVING PARTS HAVE STOPPED BEFORE UNBLOCKING.
- USE CLEAN-OUT TOOL OR WOODEN STICK TO UNBLOCK DISCHARGE CHUTE.

777D18152

CRAFTSMAN

208cc OVERHEAD VALVE

777D16340

CRAFTSMAN

777I22363

DRIVE AUGER LOCK



STOP





777D16355

CRAFTSMAN

777I23031

2 1 ← 1 2 3 4 5 6 →

777I23030

AUGER CONTROL



CHUTE DIRECTIONAL CONTROL



STARTING INSTRUCTIONS:

- 1.) INSERT IGNITION KEY AND SNAP IN PLACE.
- 2.) SET CHOKE AND THROTTLE TO FULL (ON) POSITION. PUSH PRIMER SW.
- 3.) ROPE START: PULL SLOWLY UNTIL HARDER TO PULL, THEN PULL RAPIDLY TO START. REPEAT PRIMING IF NEEDED.
- 4.) MOVE CHOKE SLOWLY TO OFF POSITION.
- 5.) TO STOP ENGINE: MOVE THROTTLE TO STOP POSITION.

ELECTRIC START: DO NOT USE IN RAIN. CONNECT POWER CORD AND PUSH STARTER BUTTON. REPEAT PRIMING IF NEEDED.

DRIVE CONTROL



777D18044

CRAFTSMAN

CLEARING WIDTH 24"

ELECTRIC START

FEDERAL and/or CALIFORNIA EMISSION CONTROL WARRANTY STATEMENT

YOUR WARRANTY RIGHTS AND OBLIGATIONS

MTD Consumer Group Inc, the United States Environmental Protection Agency (EPA), and for those products certified for sale in the state of California, the California Air Resources Board (CARB) are pleased to explain the emission (evaporative and/or exhaust) control system (ECS) warranty on your 2013 and later small off-road spark-ignited engine and equipment (outdoor equipment engine). In California, new outdoor equipment engines must be designed, built and equipped to meet the State's stringent anti-smog standards (in other states, outdoor equipment engines must be designed, built, and equipped to meet the U.S. EPA small off-road spark ignition engine regulations). MTD Consumer Group Inc must warrant the ECS on your outdoor equipment engine for the period of time listed below, provided there has been no abuse, neglect, or improper maintenance of the outdoor equipment engine.

Your ECS may include parts such as the carburetor, fuel-injection system, ignition system, catalytic converter, fuel tanks, fuel lines, fuel caps, valves, canisters, filters, vapor hoses, clamps, connectors, and other associated emission-related components.

Where a warrantable condition exists, MTD Consumer Group Inc will repair your outdoor equipment engine at no cost to you including diagnosis, parts, and labor.

MANUFACTURER'S WARRANTY COVERAGE:

This emission control system is warranted for two years. If any emission-related part on your outdoor equipment engine is defective, the part will be repaired or replaced by MTD Consumer Group Inc. In the event that a component is covered for longer than two years by the Manufacturer's equipment warranty, the longer coverage period will apply.

OWNER'S WARRANTY RESPONSIBILITIES:

As the outdoor equipment engine owner, you are responsible for performance of the required maintenance listed in your owner's manual. MTD Consumer Group Inc recommends that you retain all receipts covering maintenance on your outdoor equipment engine, but MTD Consumer Group Inc cannot deny warranty solely for the lack of receipts.

As the outdoor equipment engine owner, you should however be aware that MTD Consumer Group Inc may deny you warranty coverage if your outdoor equipment engine or a part has failed due to abuse, neglect, improper maintenance, or unapproved modifications.

You are responsible for presenting your outdoor equipment engine to MTD Consumer Group Inc's distribution center or service center as soon as the problem exists. The warranty repairs should be completed in a reasonable amount of time, not to exceed 30 days. If you have a question regarding your warranty coverage, you should contact the MTD Consumer Group Inc Service Department at 1-800-800-7310 or at <http://support.mtdproducts.com>.

GENERAL EMISSIONS WARRANTY COVERAGE:

MTD Consumer Group Inc warrants to the ultimate purchaser and each subsequent purchaser that the outdoor equipment engine is: (1) designed, built, and equipped so as to conform with all applicable regulations; and (2) free from defects in materials and workmanship that cause the failure of a warranted part for a period of two years.

The warranty period begins on the date the outdoor equipment engine is delivered to an ultimate purchaser or first placed into service.

Subject to certain conditions and exclusions as stated below, the warranty on emission-related parts is as follows:

1. Any warranted part that is not scheduled for replacement as required maintenance in the written instructions supplied is warranted for the warranty period stated above. If the part fails during the period of warranty coverage, the part will be repaired or replaced by MTD Consumer Group Inc according to subsection (4) below. Any such part repaired or replaced under warranty will be warranted for the remainder of the period.
2. Any warranted part that is scheduled only for regular inspection in the written instructions supplied is warranted for the warranty period stated above. Any such part repaired or replaced under warranty will be warranted for the remaining warranty period.
3. Any warranted part that is scheduled for replacement as required maintenance in the written instructions supplied is warranted for the period of time before the first scheduled replacement date for that part. If the part fails before the first scheduled replacement, the part will be repaired or replaced by MTD Consumer Group Inc according to subsection (4) below. Any such part repaired or replaced under warranty will be warranted for the remainder of the period prior to the first scheduled replacement point for the part.
4. Repair or replacement of any warranted part under the warranty provisions herein must be performed at a warranty station at no charge to the owner.
5. Notwithstanding the provisions herein, warranty services or repairs will be provided at all of our distribution centers that are franchised to service the subject engines or equipment.
6. The outdoor equipment engine owner will not be charged for diagnostic labor that is directly associated with diagnosis of a defective, emission-related warranted part, provided that such diagnostic work is performed at a warranty station.
7. MTD Consumer Group Inc is liable for damages to other engine or equipment components proximately caused by a failure under warranty of any warranted part.
8. Throughout the off-road engine and equipment warranty period stated above, MTD Consumer Group Inc will maintain a supply of warranted parts sufficient to meet the expected demand for such parts.
9. Any replacement part may be used in the performance of any warranty maintenance or repairs and must be provided without charge to the owner. Such use will not reduce the warranty obligations of MTD Consumer Group Inc.

-
10. Add-on or modified parts that are not exempted by the Air Resources Board may not be used. The use of any non-exempted add-on or modified parts by the ultimate purchaser will be grounds for disallowing a warranty claims. MTD Consumer Group Inc will not be liable to warrant failures of warranted parts caused by the use of a non-exempted add-on or modified part.

WARRANTED PARTS:

The repair or replacement of any warranted part otherwise eligible for warranty coverage may be excluded from such warranty coverage if MTD Consumer Group Inc demonstrates that the outdoor equipment engine has been abused, neglected, or improperly maintained, and that such abuse, neglect, or improper maintenance was the direct cause of the need for repair or replacement of the part. That notwithstanding, any adjustment of a component that has a factory installed, and properly operating, adjustment limiting device is still eligible for warranty coverage. Further, the coverage under this warranty extends only to parts that were present on the off-road engine and equipment purchased.

The following emission warranty parts are covered (if applicable):

1. Fuel Metering System
 - Cold start enrichment system (soft choke)
 - Carburetor and internal parts (or fuel injection system)
 - Fuel pump
 - Fuel tank
2. Air Induction System
 - Air cleaner
 - Intake manifold
3. Ignition System
 - Spark plug(s)
 - Magneto ignition system
4. Exhaust System
 - Catalytic converter
 - SAI (Reed valve)
5. Miscellaneous Items Used in Above System
 - Vacuum, temperature, position, time sensitive valves and switches
 - Connectors and assemblies
6. Evaporative Control
 - Fuel hose
 - Fuel hose clamps
 - Tethered fuel cap
 - Carbon canister
 - Vapor lines

REPAIR PROTECTION AGREEMENT

Congratulations on making a smart purchase. Your new Craftsman® product is designed and manufactured for years of dependable operation. But like all products, it may require repair from time to time. That's when having a Repair Protection Agreement can save you money and aggravation.

Here's what the Repair Protection Agreement* includes:

- ☑ **Expert service** by our 10,000 professional repair specialists
- ☑ **Unlimited service and no charge** for parts and labor on all covered repairs
- ☑ **Product replacement** up to \$1500 if your covered product can't be fixed
- ☑ **Discount of 25%** from regular price of service and related installed parts not covered by the agreement; also, 25% off regular price of preventive maintenance check
- ☑ **Fast help by phone** – we call it Rapid Resolution – phone support from a Sears representative. Think of us as a “talking owner's manual.”

Once you purchase the Repair Protection Agreement, a simple phone call is all that it takes for you to schedule service. You can call anytime day or night, or schedule a service appointment online.

The Repair Protection Agreement is a risk-free purchase. If you cancel for any reason during the product warranty period, we will provide a full refund. Or, a prorated refund anytime after the product warranty period expires. Purchase your Repair Protection Agreement today!

Some limitations and exclusions apply. For prices and additional information in the U.S.A. call 1-800-827-6655.

***Coverage in Canada varies on some items. For full details call Sears Canada at 1-800-361-6665.**

Sears Installation Service

*For Sears professional installation of home appliances, garage door openers, water heaters, and other major home items, in the U.S.A. or Canada call **1-800-4-MY-HOME®**.*

Get it fixed, at your home or ours!

Your Home

For troubleshooting, product manuals and expert advice:



www.managemylife.com

For repair – **in your home** – of **all** major brand appliances, lawn and garden equipment, or heating and cooling systems, **no matter who made it, no matter who sold it!**

For the replacement parts, accessories and owner's manuals that you need to do-it-yourself.

For Sears professional installation of home appliances and items like garage door openers and water heaters.

1-800-4-MY-HOME[®] (1-800-469-4663)

Call anytime, day or night (U.S.A. and Canada)

www.sears.com www.sears.ca

Our Home

For repair of carry-in items like vacuums, lawn equipment, and electronics, call anytime for the location of your nearest

Sears Parts & Repair Service Center

1-800-488-1222 (U.S.A.)

www.sears.com

1-800-469-4663 (Canada)

www.sears.ca

To purchase a protection agreement on a product serviced by Sears:

1-800-827-6655 (U.S.A.)

1-800-361-6665 (Canada)

Para pedir servicio de reparación a domicilio, y para ordenar piezas:

1-888-SU-HOGAR[®]

(1-888-784-6427)

www.sears.com

Au Canada pour service en français:

1-800-LE-FOYER^{MC}

(1-800-533-6937)

www.sears.ca

sears

® Registered Trademark / TM Trademark of KCD IP, LLC in the United States, or Sears Brands, LLC in other countries

® Marca Registrada / TM Marca de Fábrica de KCD IP, LLC en Estados Unidos, o Sears Brands, LLC in otros países

^{MC} Marque de commerce / ^{MD} Marque déposée de Sears Brands, LLC