



R-807

NETWORK AV RECEIVER
RÉCEPTEUR RÉSEAU AV
RECEPTOR A/V CON CONEXIÓN DE RED
NETZWERK-AV-RECEIVER
СЕТЕВОЙ AV-РЕСИВЕР

OPERATING INSTRUCTIONS
GUIDE D'UTILISATION
INSTRUCCIONES DE FUNCIONAMIENTO
BEDIENUNGSANLEITUNG
ИНСТРУКЦИЯ ПО ЭКСПЛУАТАЦИИ

Safety Information

READ THIS BEFORE OPERATING YOUR UNIT





CAUTION
RISK OF ELECTRIC SHOCK
DO NOT OPEN



CAUTION
TO REDUCE THE RISK OF ELECTRIC SHOCK, DO NOT REMOVE FRONT OR BACK COVER. NO USER-SERVICEABLE PARTS INSIDE. REFER SERVICING TO QUALIFIED SERVICE PERSONNEL.

CE R&TTE Directive 1999/5/EC

 This symbol indicates the presence of uninsulated “dangerous voltage” within the product’s enclosure that may be of sufficient magnitude to constitute a risk of electric shock.

 This symbol indicates important operating and maintenance (servicing) instructions in the literature accompanying the appliance.

WARNING: TO REDUCE THE RISK OF FIRE OR ELECTRIC SHOCK, DO NOT EXPOSE THIS APPLIANCE TO RAIN OR MOISTURE.

CAUTION

- Leave space around the unit for sufficient ventilation.
- Avoid installation in extremely hot or cold locations, or in an area that is exposed to direct sunlight or heating equipment.
- Keep the unit free from moisture, water, and dust.
- Do not let foreign objects in the unit.
- Keep the ventilation openings clear of items, such as newspapers, linens, or curtains.
- Keep open flame from candles or other sources away from the unit.
- Observe the local regulations regarding disposal of packaging materials, exhausted batteries and old equipment.
- Do not expose the unit to dripping or splashing, or place objects filled with liquids such as vases.
- Do not let insecticides, benzene, or thinner come in contact with the unit.
- Never disassemble or modify the unit in any way.

Notes on the AC power cord and the wall outlet

- The unit remains connected to AC power as long as it is plugged into the wall outlet, even if the unit has been turned off.
- To completely disconnect this product from AC power, disconnect the plug from the wall socket outlet.
- When setting up this product, make sure that the AC outlet you are using is easily accessible.
- Disconnect the plug from the wall outlet when not using the unit for long periods of time.

Caution regarding installation

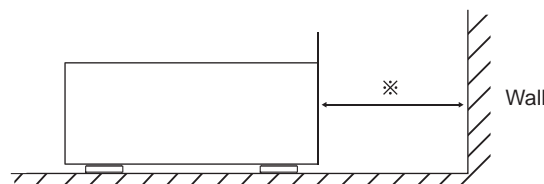
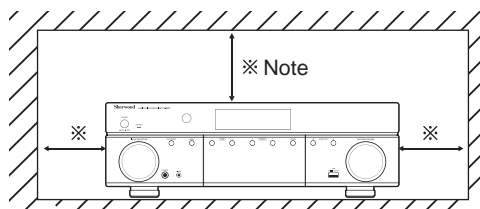

Do not block ventilation openings or stack other equipment on the top.

※ **Note:** For heat dispersal, do not install this unit in a confined space such as a bookcase or similar enclosure.

Table of Contents

2 SAFETY INFORMATION

5 GETTING STARTED

- 5 What's Included
- 6 Installing the Remote Control Battery
- 6 Operating the range of the Remote Control

7 PARTS DESCRIPTION

- 7 Front Panel
- 8 Front Display
- 8 Rear Panel
- 9 Remote Control

10 MAKING CONNECTIONS

- 10 Connection Overview
- 11 Connecting Speakers
 - 11 Placing Speakers
 - 13 Connecting Speakers
 - 14 Setting the Speaker
- 15 Connecting a TV
 - 15 Connecting with an HDMI TV
 - 16 Connecting with a non-HDMI TV
- 17 Connecting Playback Components
 - 17 Connecting HDMI Components
 - 17 Connecting Video Components
 - 18 Connecting Audio Components
 - 20 Connecting Recording Components
- 20 Connecting to a Network
- 21 Connecting an Antenna
 - 21 Connecting FM Antenna
 - 22 Connecting AM Antenna
- 23 Connecting to Muti-Room
 - 24 Connecting to the System's Internal Amplifier
 - 24 Connecting to an External Amplifier
 - 25 Controlling Room2
- 25 Connecting Power

26 OPERATING YOUR SYSTEM

- 26 Listening to Your System
 - 26 Basic Operation
 - 26 Muting the Sound
- 27 Enjoying Surround Effects
 - 27 Setting the Surround Mode
 - 30 Cancelling the Surround Mode for Stereo Operation
 - 30 Adjusting the Current Channel Level
- 31 Listening to Music on USB
 - 31 To Stop Playback
 - 31 To Pause Playback
 - 31 To Skip Forward or Backward
 - 32 To Play Repeatedly
 - 32 To Play Randomly
- 32 Listening to Internet Radio
- 33 Listening to Music from the Media Server
 - 33 Configuring the Windows Media Player
 - 34 Listening to Music from the Media Server
- 34 Using the Sherwood Remote Application
 - 34 Preparing for the Application
 - 35 Using the Application
- 39 Listening to FM Radio
 - 39 Auto Tuning
 - 39 Manual Tuning
 - 39 Manual Presetting
 - 40 Auto Presetting
 - 40 Tuning in to Preset Stations
 - 40 RDS Tuning
- 41 Recording

42 CUSTOMIZING SETTINGS

- 42 Setting the System
- 43 Setting Options Overview
- 44 Setting the System Setup
 - 44 AMP Assign
 - 44 Automatic Power Control
 - 44 Network Standby Control
- 44 Setting the Speaker Setup
 - 44 Auto Setup
 - 46 Speaker Setup
 - 46 Speaker Crossover
 - 46 Speaker Distance
 - 46 Speaker Channel Level
- 47 Setting the HDMI Setup
 - 47 HDMI
 - 47 CEC Control
- 47 Setting the Surround Parameter Setup
 - 47 Height Gain
 - 47 PANORAMA
 - 47 Center Width
 - 47 Dimension
 - 47 Center Image
 - 48 DRC
 - 48 Tone
 - 48 Sound Delay
 - 48 Low Frequency Effect
- 49 Setting the Multi Room Setup
- 49 Setting the Network Setup
 - 49 Network Settings Overview
 - 49 Setting the Direct Wireless Network Connection
 - 50 Setting the Wired Network Connection
 - 50 Setting Other Network Options
 - 50 Viewing the Network Information

51 TROUBLESHOOTING

- 51 GENERAL
- 51 SOUND
- 52 VIDEO
- 53 USB device
- 54 NETWORK CONNECTION
- 54 Important Information Regarding the HDMI Connection

55 ADDITIONAL INFORMATION

- 55 Specifications
- 56 Trademarks and Licenses
 - 56 DTS-HD Master Audio
 - 56 Dolby TrueHD
 - 56 HDMI

Getting Started

What's Included

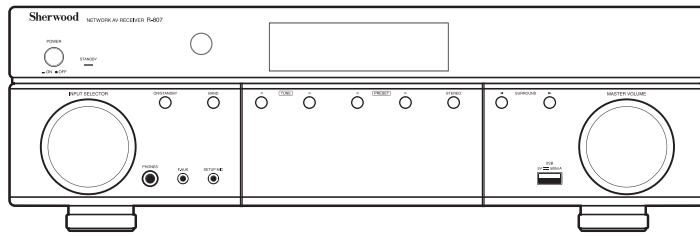

Main unit

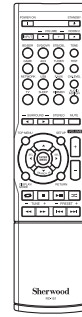

Remote control (1 ea)

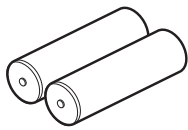

Battery

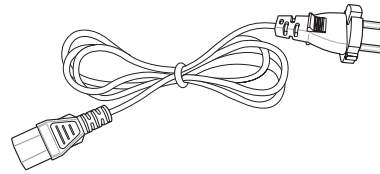

Power Cable (1 ea)

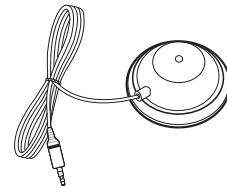

Setup Mic (1 ea)

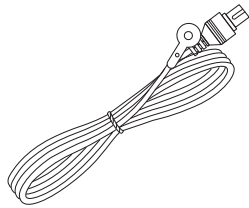

FM antenna (1 ea)



AM Antenna (1 ea)

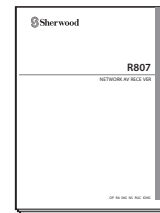

User Manual

Installing the Remote Control Battery

- 1 Remove the battery cover.

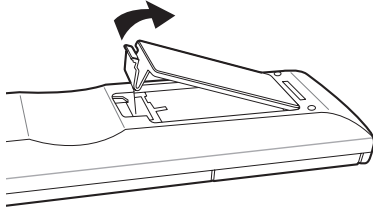

- 2 Insert two AAA size batteries with the polarity matched properly.

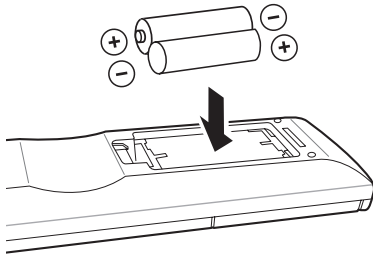

! Caution

- Always use alkaline batteries, and do not use the rechargeable batteries (Ni-Cd type).
- If the batteries run out, remove the old batteries and replace them with new ones within several minutes.
- If the batteries are removed or have been exhausted for a longer period of time, memorized contents will be cleared. In this case, you should memorize them again.
- If the battery is placed incorrectly, it can cause explosion.
- Remove the battery if the remote control is not used for a long period of time.
- Do not leave the product in a hot or humid place.
- Do not handle and store the battery with metallic tools.

Operating the range of the Remote Control

Use the remote control within a range of about 7 meters (23 feet) and angles of up to 30 degrees aiming at the remote control sensor.

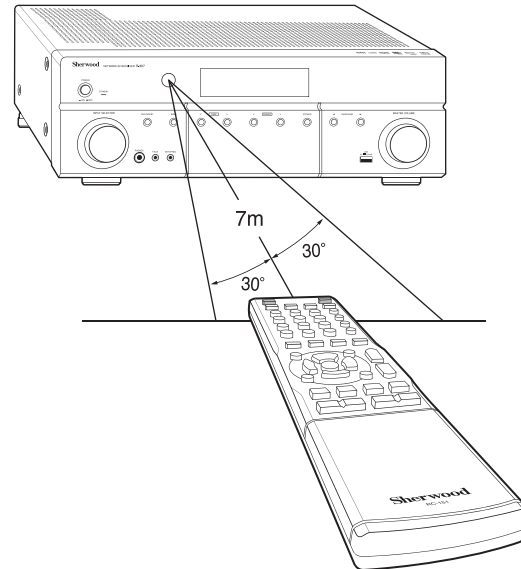

Parts Description

Front Panel

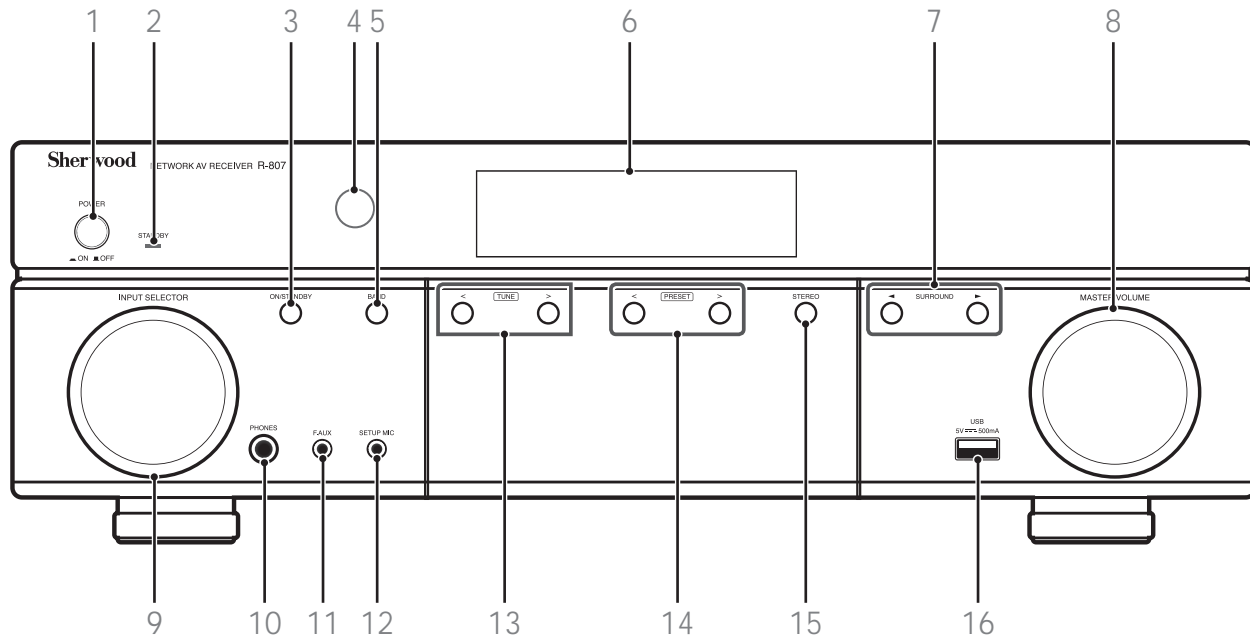

- | | | | |
|---|-------------------------|----|------------------------|
| 1 | Main Power Switch | 9 | Input Selector |
| 2 | Standby Indicator | 10 | Headphone Connector |
| 3 | On/Standby Switch | 11 | Aux Input Connector |
| 4 | IR Sensor | 12 | Setup MIC Connector |
| 5 | Band Select Button | 13 | Tuning Up/Down Buttons |
| 6 | Display | 14 | Preset Select Buttons |
| 7 | Surround Select Buttons | 15 | Stereo Mode Button |
| 8 | Master Volume Control | 16 | USB Port |

R-807 NETWORK AV RECEIVER

Front Display

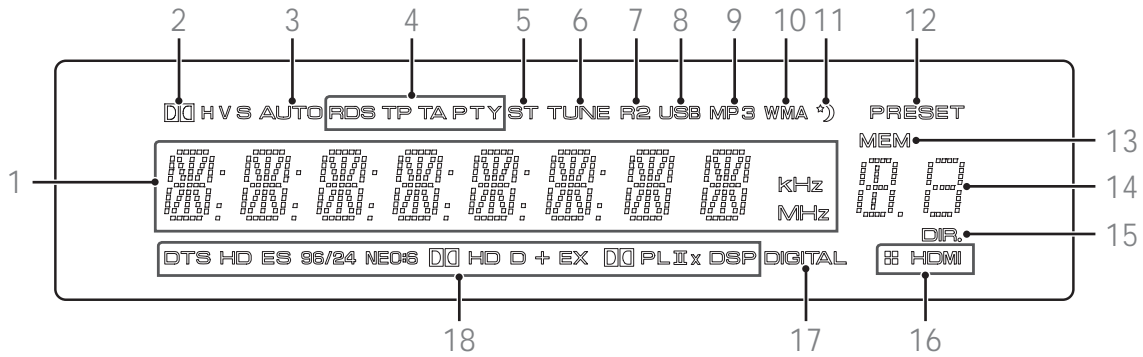

- | | | | |
|---|----------------------------------|----|--|
| 1 | Information Display | 10 | WMA Indicator |
| 2 | Dolby Digital Surround indicator | 11 | Sleep Timer Indicator |
| 3 | Auto Detecting Indicator | 12 | Preset Indicator |
| 4 | RDS Indicators | 13 | Station Memory Indicator |
| 5 | Stereo Indicator | 14 | Preset Station Indicator |
| 6 | Tuning indicator | 15 | Direct Indicator |
| 7 | Room2 Indicator | 16 | HDMI Indicator |
| 8 | USB Indicator | 17 | Digital Input Indicator |
| 9 | MP3 Indicator | 18 | Dolby/DTS/DSP Surround mode indicators |

Rear Panel

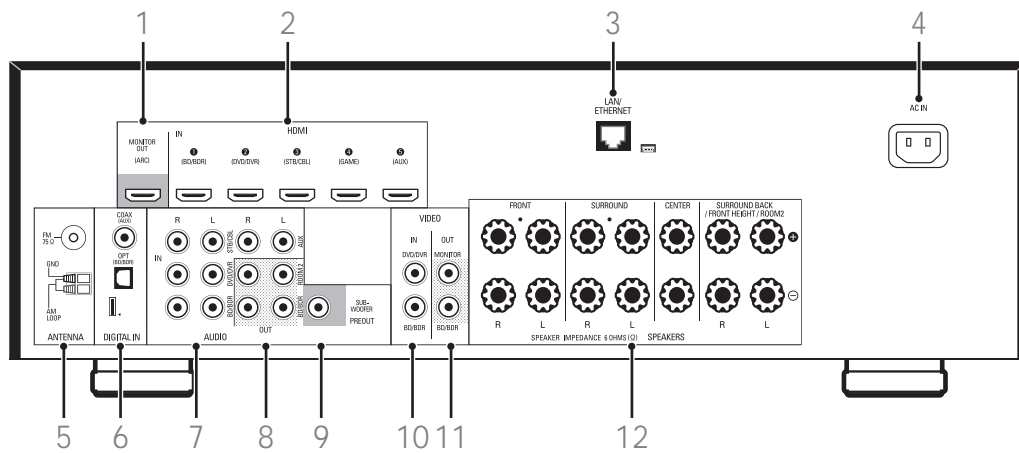

- | | | | |
|---|-----------------------------|----|-----------------------------------|
| 1 | Monitor OUT (ARC) Connector | 7 | Analog Audio Input Connectors |
| 2 | HDMI Connectors | 8 | Analog Audio Output Connectors |
| 3 | LAN/ETHERNET Connector | 9 | Subwoofer Connector |
| 4 | AC Input Connector | 10 | Composite Video Input Connectors |
| 5 | Radio Antenna Connectors | 11 | Composite Video Output Connectors |
| 6 | Digital Audio Connectors | 12 | Speaker Connectors |

Remote Control

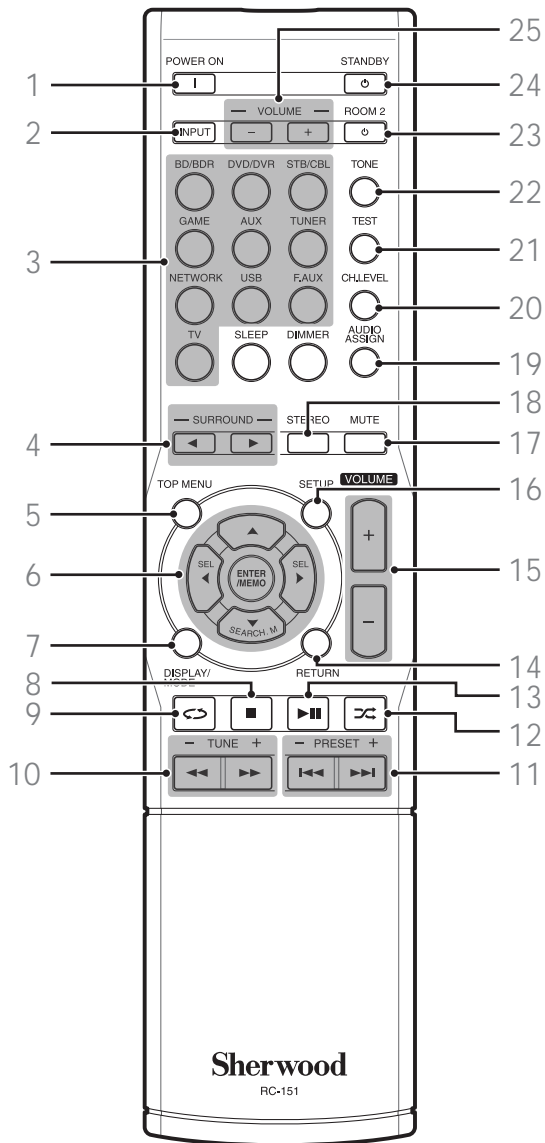

- 1 Power On Button
- 2 Room2 Input Select Button
- 3 Source Select Buttons
- 4 Surround Select Buttons
- 5 Top Menu Button
- 6 ▲/▼/◀/▶ Select Buttons
- ENTER/MEMO Enter/Memory Button
- SEARCH.M RDS Search Button
- 7 Display/Mode Button
- 8 Stop Button
- 9 Repeat Button
- 10 Tuning Up/Down Buttons
Rewind/Fast forward Buttons
- 11 Preset Station Up/Down Buttons
Previous/Next Buttons
- 12 Random Button
- 13 Play/Pause Button
- 14 Return Button
- 15 Volume Up/Down Buttons
- 16 Setup Menu Button
- 17 Mute Button
- 18 Stereo Mode Button
- 19 Audio Assign Button
- 20 Channel Level Button
- 21 Test Tone Sequence Button
- 22 Tone Control Button
- 23 Room2 ON/OFF Button
- 24 Standby Button
- 25 Room2 Volume Up/Down Buttons

Making Connections

Connection Overview

Connect various external devices to the ports on the main unit.

- 1 Find an external device you want to connect to the main unit as shown on the following illustration.
- 2 Check the connection type of the external device.
- 3 Go to the appropriate illustration and check the connection details.

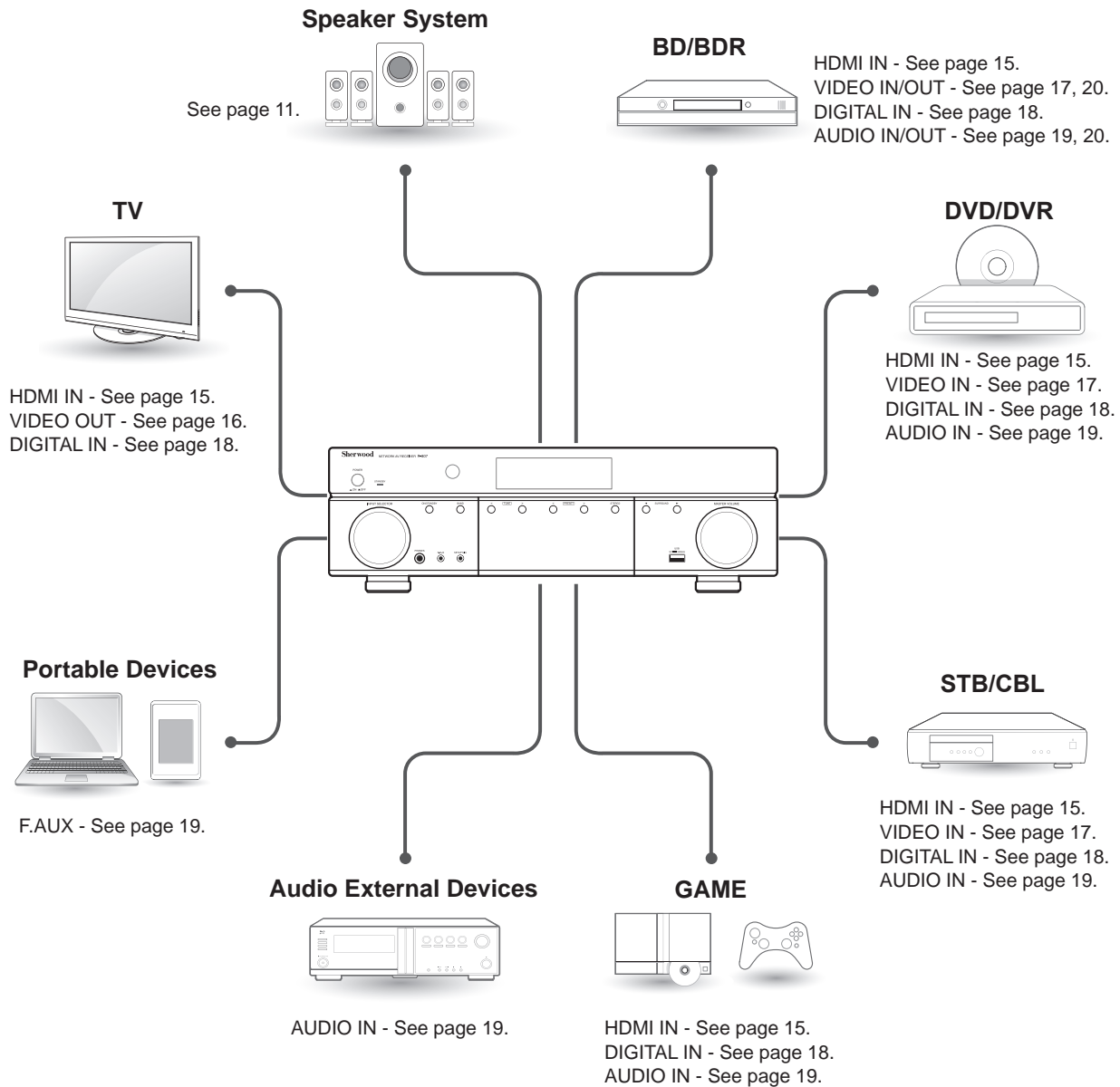

Connecting Speakers

Placing Speakers

Determine the locations for your speaker placement according to their manufacturer's directions and the layout of your listening room. Use the illustration on page 12 as a guide for speaker placement.

To create the most realistic surround-sound environment possible, you should place your speakers in a circle around the listener. You should angle each speaker so it directly faces the listening position. Use the diagram below as a guide.

Speaker Type	Abbr.	Speaker System						
		7.1 Channel (for Dolby Pro Logic IIz playback)	7.1 Channel	6.1 Channel	5.1 Channel	4.1 Channel	3.1 Channel	2.1 Channel
Front Left	FL	•	•	•	•	•	•	•
Front Right	FR	•	•	•	•	•	•	•
Front Height Left	FHL	•						
Front Height Right	FHR	•						
Center	C	•	•	•	•		•	
Subwoofer	SW	•	•	•	•	•	•	•
Surround Left	SL	•	•	•	•	•		
Surround Right	SR	•	•	•	•	•		
Surround Back Left	SBL		•					
Surround Back Right	SBR		•					
Surround Back	SB			•				



Note

- If you're using only one surround back speaker, connect it to the surround back left speaker terminals.
- Front high and surround back speakers cannot be used at the same time.
- To avoid interference with the TV picture when using a conventional TV, use only magnetically shielded front left, right, and center speakers.
- To obtain the best surround effects, all the speakers except the subwoofer should be full range speakers.

Front left and right speakers and center speaker

- Place the front speakers with their front surfaces as flush to the TV or monitor screen as possible.
- Place the center speaker between the front left and right speakers and its distance should not be further from the listener than the front speakers.
- Place each speaker so that sound is aimed at where listener's ears would be in the main listening position.

Surround left and right speakers

- Place the surround speakers approximately 60 ~ 90 cm (24 ~ 36 inches) above on the direct left/right side or slightly behind the ear level of a seated listener.

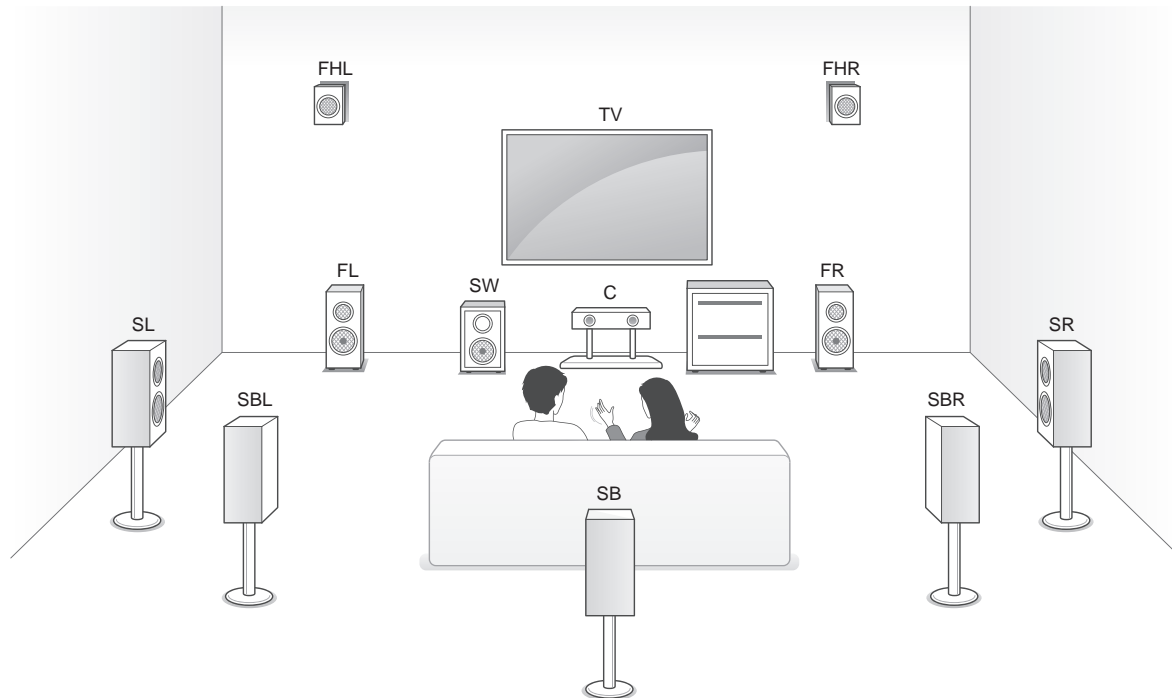

Surround back left and right speakers

- Place the surround back speakers at the back facing forward together and closer than front speakers.
- When using a single surround back speaker, place it at the rear center facing forward at a slightly higher position (0 to 20 cm) than the surround speakers.
- We recommend installing the surround back speaker(s) facing slightly. This effectively prevents the surround back channel signals from bouncing off the TV or screen at the front center, resulting in interference and making the sense of movement from the front to the back less sharp.

Subwoofer

Because a room's shape and volume can have a dramatic effect on a subwoofer's performance, you should experiment with placement in order to find the location that produces the best results in your particular listening room. With that in mind, these rules will help you get started.

- Placing the subwoofer next to a wall generally will increase the amount of bass in the room.
- Placing the subwoofer in a corner generally will maximize the amount of bass in the room.
- In many rooms, placing the subwoofer along the same plane as the left and right speakers can produce the best integration between the sound of the subwoofer and that of the left and right speakers.

- In some rooms, the best performance comes from placing the subwoofer behind the listener. A good way to determine the best location for the subwoofer is by temporarily placing it in the listening position and playing music with strong bass content. Move around to various locations in the room while the system is playing (putting your ears where the subwoofer would be placed), and listen until you find the location where the bass performance is best. Place the subwoofer in that location.

Front height left and right speakers (Recommended for Dolby Pro Logic IIz playback)

- Place the front height speakers at least 1 meter (40 inches) above the front speakers.

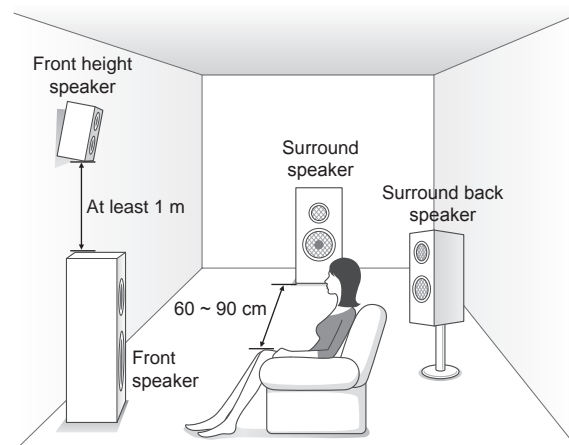

Connecting Speakers

Carefully check the left (L) and right (R) channels and the polarities on the speakers being connected to this receiver.

Connecting Speaker Wires

- 1 Strip away approx. 10 mm (3/8 inch) of wire insulation, and then tightly twist the wire ends.



- 3 Insert the bare part of the wire.



- 2 Loosen the speaker terminal by turning it counter-clockwise.



- 4 Tighten the speaker terminal by turning it clockwise.

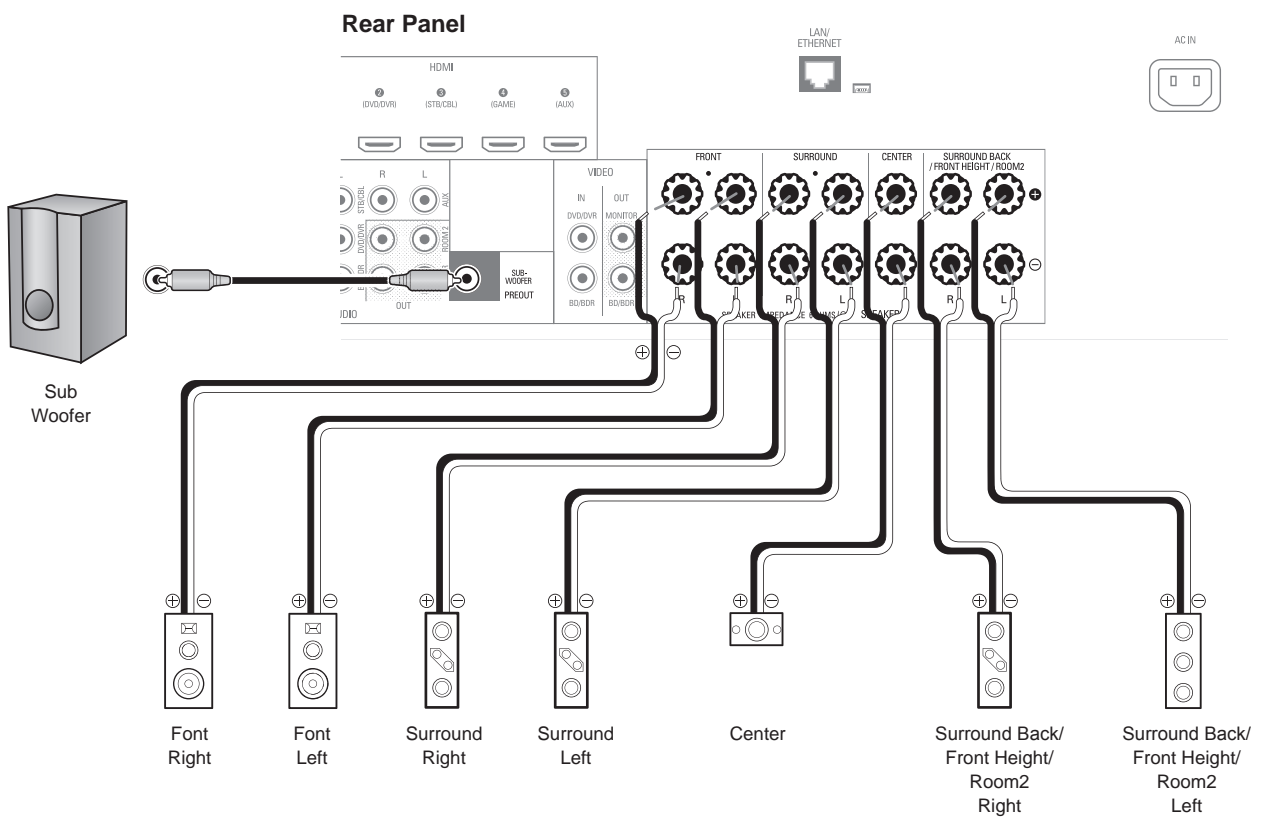

R-807 NETWORK AV RECEIVER

- Be sure to connect speakers firmly and accurately according to the channel (left and right) and the polarity (+ and -). If the connections are incorrect, no sound will be produced by the speakers, and if the polarity of the speaker connection is incorrect, the sound will be unnatural and tinny.
- When listening in Dolby Pro Logic IIz mode, connect the front height speakers.
- To install the speakers, see “Placing Speakers” on page 11.
- For ROOM 2 playback, connect the ROOM 2 speakers. For details, see “Connecting to Multi-Room” on page 23.
- After installing the speakers, first adjust the speaker settings according to your environment and speaker layout. For details, see “Setting the Speaker”.

! Caution

- Be sure to use the speakers with the impedance of 6 ohms or above.
- Do not let bare speaker wires touch each other or any metal part of this receiver. This could damage the main unit and/or the speakers.
- Never touch the speaker terminals while the AC input cord is connected to the wall AC outlet. Doing so could result in electric shock.

Setting the Speaker

You will be using the following remote control buttons to configure the main unit. For details on the speaker setup, see page 44.

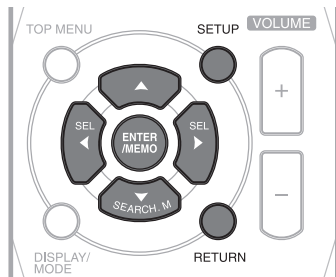

- 1 Turn on your TV and select the TV input.

Note

- Although you can configure the main unit using only its front-panel message display, it is much easier to use the On-Screen Display (OSD) menu system.

- 2 Press the remote control's SETUP button. The main unit's OSD System Setup menu will appear on the TV.
- 3 Use the remote's arrow and ENTER buttons to select “Speaker Setup”. The Speaker Setup menu will appear.
- 4 Select “Speaker Settings”. The Speaker Settings menu will appear.
- 5 Use the remote's left and right arrow buttons to select OFF, SMALL or LARGE for the Front, Center and Surround speaker positions, depending on the speakers you have connected to the receiver.

OFF: Select this setting if you have not connected a speaker in that position (not available for the front speakers).

SMALL: Select this setting if the speaker is not capable of producing clean, deep bass energy at output levels that match those produced by a powered subwoofer. All bass in that channel is removed from that speaker and is sent to the subwoofer (or to the front speakers if subwoofer is set to NO). Most speakers (unless they are large and powerful) should be considered SMALL.

LARGE: Select this setting if the speaker is capable of producing clean, deep bass energy at output levels that match those produced by a powered subwoofer. All bass in that channel is sent to that speaker.

When you're finished, press the remote control's RETURN button to return to the Speaker Setting menu.

Note

- If your system has a subwoofer and you set the front speakers to LARGE, the subwoofer may only play Dolby Digital-audio signals and DTS-encoded program material that contains LFE channel information. If you set your front speakers to LARGE and you want your subwoofer to reproduce bass from all program material, set the Subwoofer to PLUS (see below).
- For subwoofer, select YES (if your system has a subwoofer), NO (if your system does not have a subwoofer), or PLUS (if your system has a subwoofer, you set your front speakers to LARGE and you want your subwoofer to reproduce bass from all program material).

- 6 You can skip the “Crossover” setting.
- 7 Select “Speaker Distance”. The Speaker Distance menu will appear.
- 8 Measure the distance from each speaker in your system to the listener. Set the distances.
- 9 Use the remote’s left and right arrow buttons to change the distance setting for each speaker so that it matches the distance you wrote down in step 8. When you’re finished, press the remote control’s RETURN button to return to the Speaker Setting menu.
- 10 Select “Channel Level”. The Channel Level menu will appear. Use the remote’s left and right arrow buttons to set Test Tone to “Manual” and press the remote’s ENTER button. After the on-screen countdown you will hear test noise through the front left speaker.
- 11 Sit in the main listening position and adjust the main unit’s volume control so the test sound is moderately loud. Note the volume of the test sound through the first speaker. Press the remote’s down arrow button to advance the test noise to each of your system’s speakers and note the volume level of the noise in each speaker.
- 12 As you advance the test sound through the speakers, use the remote’s left and right arrow buttons to adjust the volumes of the channels until all of them play at the same volume. When you’re finished, press the remote’s SETUP button to turn off the on-screen menus.

Connecting a TV

Connecting with an HDMI TV

With HDMI, you can easily enjoy high quality sounds and images. The main unit plays audio from HDMI compatible products while also passing on the video signal to a HDMI-connected TV.

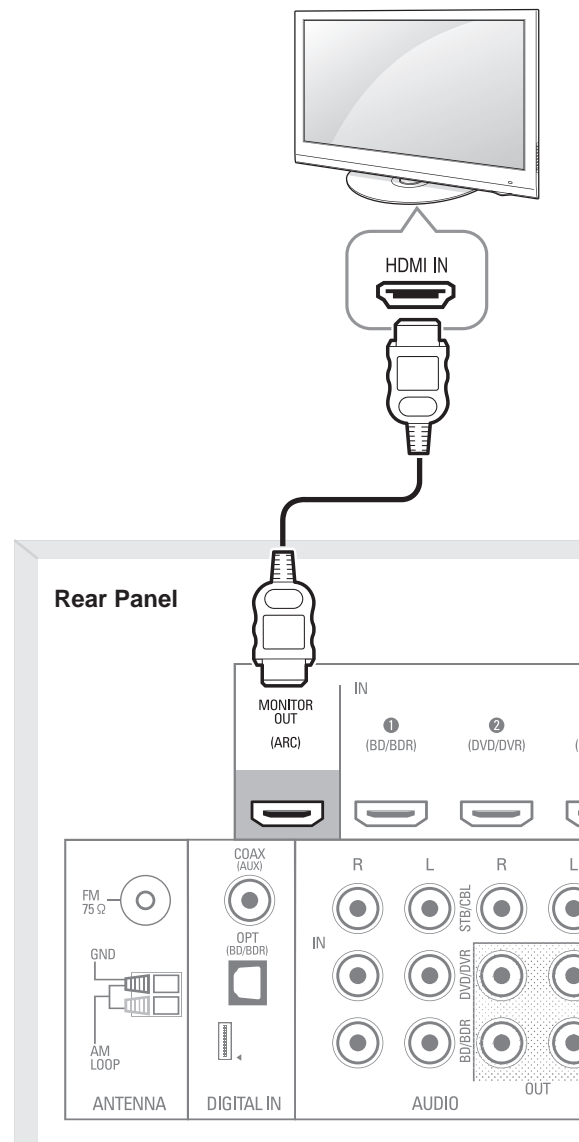

About HDMI

HDMI (High Definition Multimedia Interface) supports both audio and video on a single digital connection for use with DVD players, DTV, set-top boxes, and other AV devices. HDMI was developed to provide the technologies of High Bandwidth Digital Content Protection (HDCP) as well as Digital Visual Interface (DVI) in one specification. HDCP is used to protect the digital content transmitted and received by DVI-compliant displays.

R-807 NETWORK AV RECEIVER

HDMI has the capability to support standard, enhanced, or high-definition video plus standard to multi-channel surround-sound audio. HDMI features include uncompressed digital video, a bandwidth of up to 2.2 gigabytes per second (with HDTV signals), one connector (instead of several cables and connectors), and communication between the AV source and AV devices such as DTVs.

This main unit is also compatible with the DeepColor and x.v.Color feature (x.v.Color is trademarks of Sony Corporation).

HDMI, the HDMI logo and High-Definition Multimedia Interface are trademarks or registered trademarks of HDMI Licensing, LLC.



Note

- Check the setup of the connected component if an image is poor or there is no sound from a component connected via the HDMI cable.
- Audio signals (sampling frequency, bit length, etc.) transmitted from an HDMI jack may be suppressed by the connected component.
- When the connected component is not compatible with copyright protection technology (HDCP), the image and the sound from the HDMI TV OUT jack may be distorted or may be not output. In this case, check the specification of the connected component.
- Regardless of which input is selected for the system, the video signal from the HDMI input jack (BD, DVD, SAT) that was last selected is output from the HDMI TV OUT jack.

Confirming the HDMI control functions

To use the HDMI control functions properly, it is recommended to confirm the HDMI control functions usable with each connected component by performing the following operations.

- 1 Turn on all the components connected with HDMI cables.
- 2 Turn the TV off to standby mode.
 - Confirm that all the components are turned off.
- 3 With all the components off, start playback of a device (connected with HDMI cable).
- 4 Confirm that all the components are turned on and the inputs of the main unit and TV are switched automatically.

Connecting with a non-HDMI TV

If your TV does not have an HDMI connector, or if your TV does have an HDMI connector but you are connecting some source devices with only composite video connectors, use a composite video cable (not included) to connect the composite Monitor Out connector to your TV's composite video connector.

Rear Panel

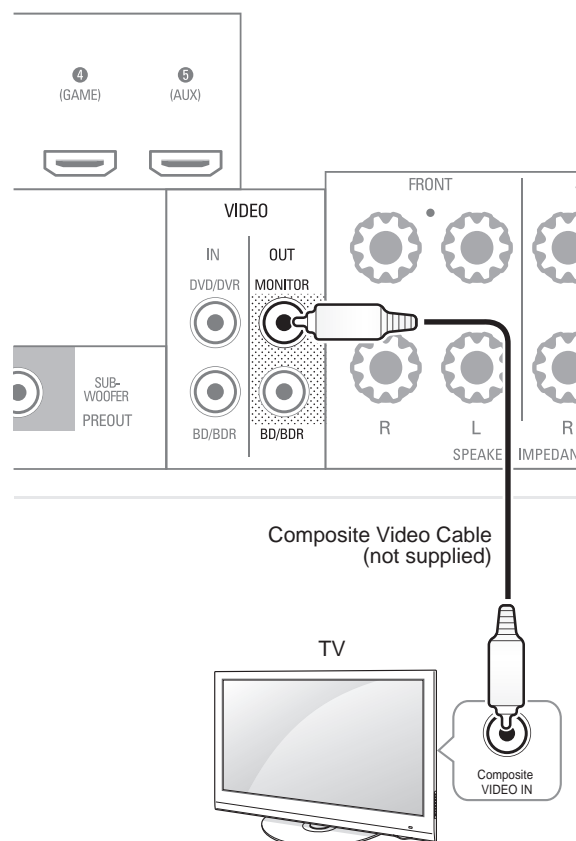

Note

- The on-screen display (OSD) only appears through the Composite Monitor Out connector. If you want to use the main unit's OSD menus you will need to connect its Composite Monitor Out connector to your TV even if you are not connecting any composite video source devices to the system.

Connecting Playback Components

Source devices are components from which a playback signal originates, e.g., a Blu-ray Disc™ or DVD player; a set-top box, or HDTV tuner, etc. The receiver has several different types of input connectors for your audio and video source devices: HDMI, composite video, optical digital audio, coaxial digital audio and analog audio.

Connecting HDMI Components

If any of your source devices have HDMI connectors, using those connectors will provide the best possible video and audio performance quality. Since the HDMI cable carries both digital video and digital audio signals, you do not have to make any additional audio connections for devices you connect via HDMI cables.

If you have an HDMI or DVI (with HDCP) equipped component (Blu-ray disc player, etc.), you can connect it to this receiver using a commercially available HDMI cable.

Rear Panel

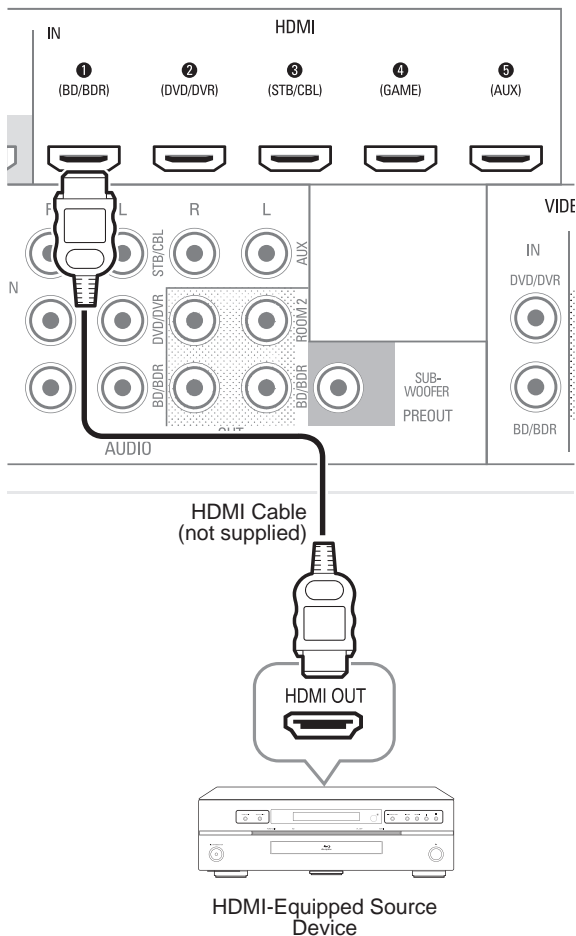

Connecting Video Components

You will need to make composite video connections from your source devices that do not have HDMI video connections. You will also need to make an audio connection from the device to the main unit.

Rear Panel

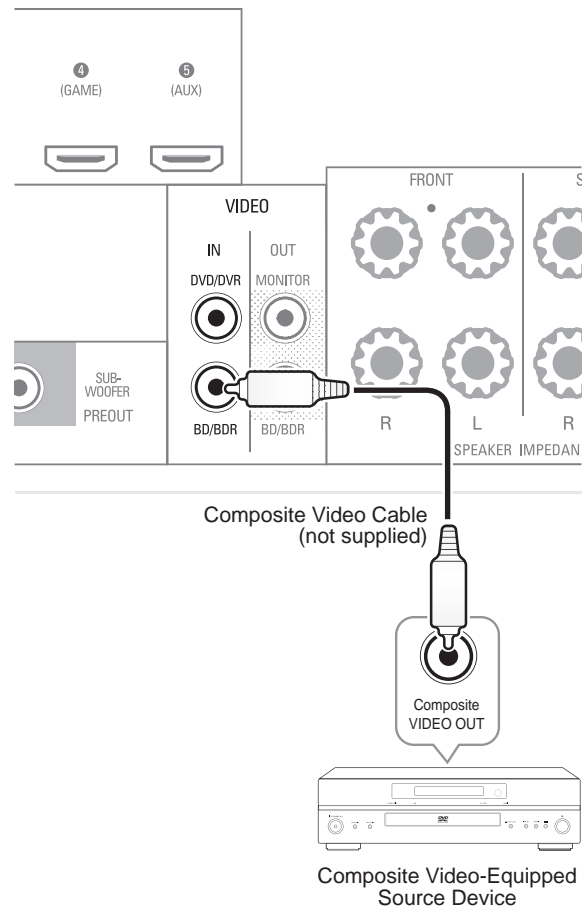

R-807 NETWORK AV RECEIVER

Connecting Audio Components

Optical Digital Audio Connection

You can connect components equipped with an optical output jack. On the main unit, you can enjoy the full sound of components, such as DVD players, set-top box, BD (Blu-ray Disc™) players or TVs.

* "Blu-ray Disc" is a trademark of Blu-ray Disc Association.

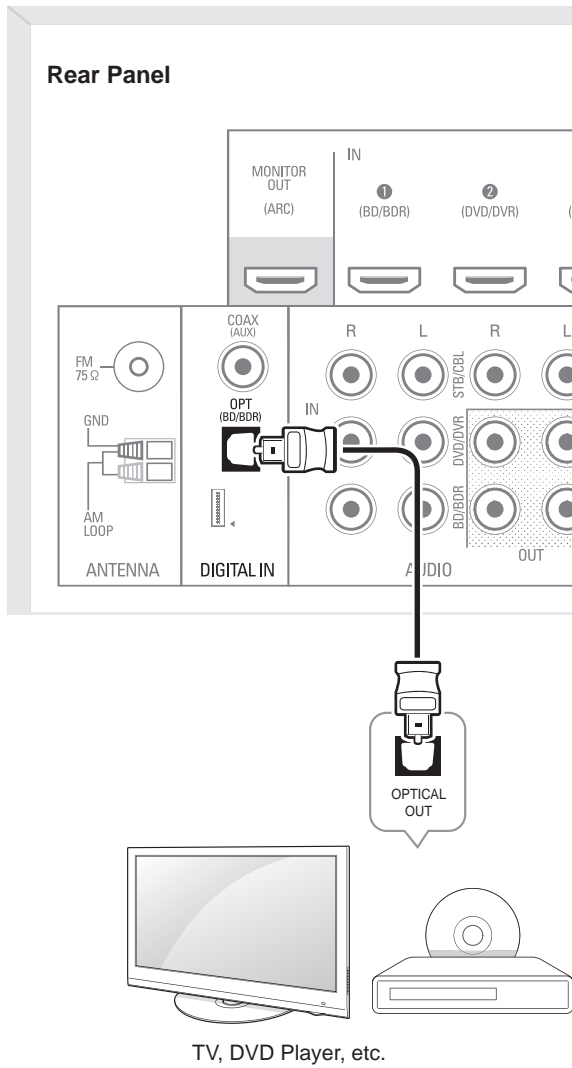

Coaxial Digital Audio Connection

If your source devices have a coaxial digital output, connect it to the main unit's coaxial digital audio connector.

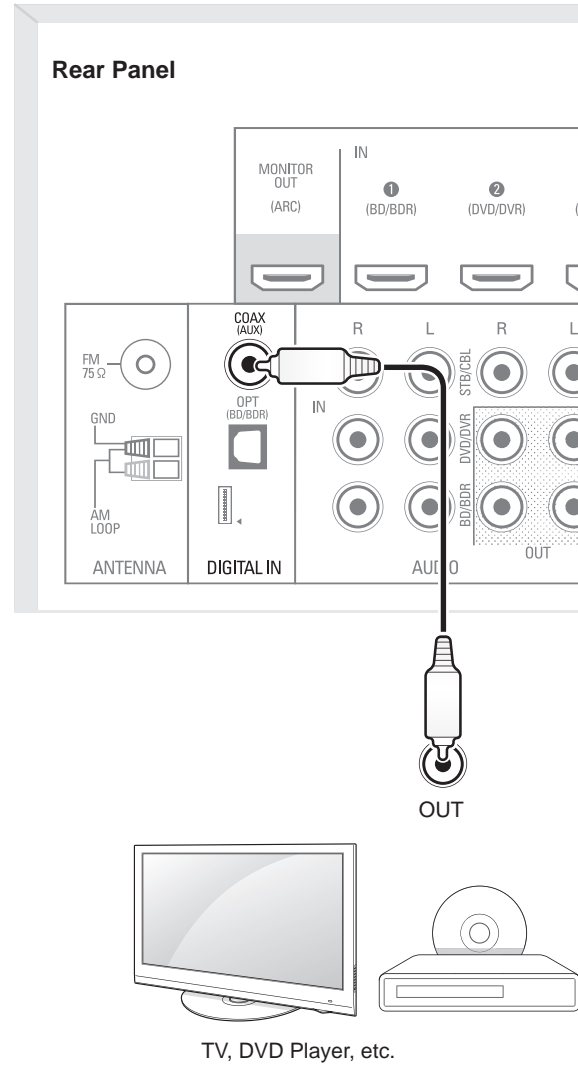

Analogue Audio Connection

Make analog audio connections from your source devices that do not have HDMI or digital audio connections. If you're connecting video sources to the main unit, you must also connect the source device's composite video output to the corresponding composite video connector.

- Ensure the left (L) and right (R) channels and the inputs and outputs are correctly connected.
- To listen to the sound of a connected audio device, select AUX as the input source.
- To listen to TV audio, select TV as the input source.

Rear Panel

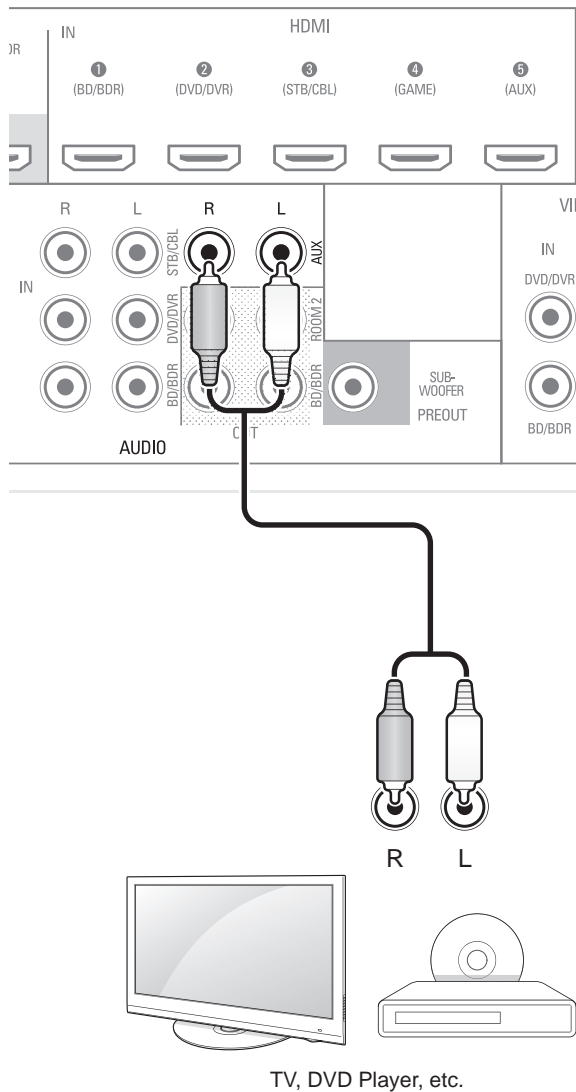

F.AUX Connection

You can use the F.AUX input jack to connect portable audio components such as an MP3 player, etc.

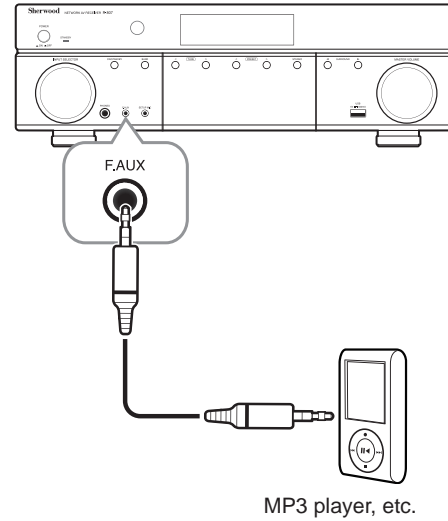

Listening with Headphones

- 1 Connect the headphones to the PHONES jack on the front panel.

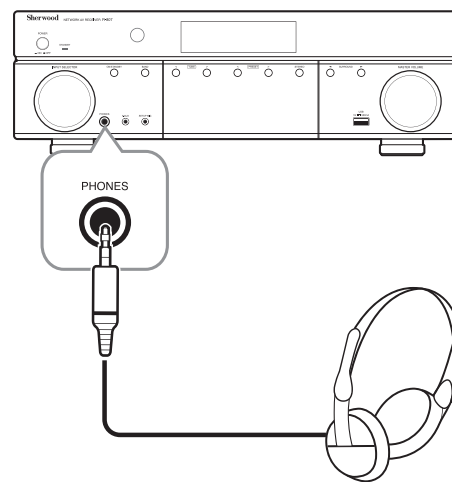

! Caution

- Be careful not to set the volume too high when using headphones.

Connecting Recording Components

You can connect video and audio recording devices to the VIDEO OUT and AUDIO OUT jacks. You can make an audio or a video recording from the built-in tuner or from an audio or video source connected to the main unit.

Rear Panel

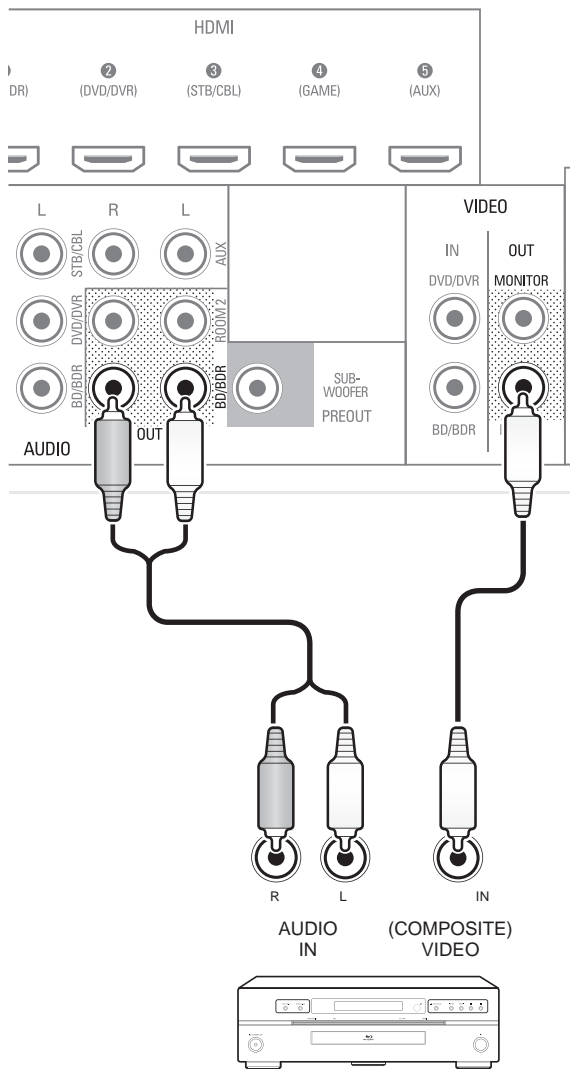

Connecting to a Network

If you have an internet connection, you can connect the main unit to the internet as well as using a wireless or a wired LAN connection.

The following illustration is a configuration example of a home network with the system and a server. It is recommended to connect the server to the router with a wired connection.

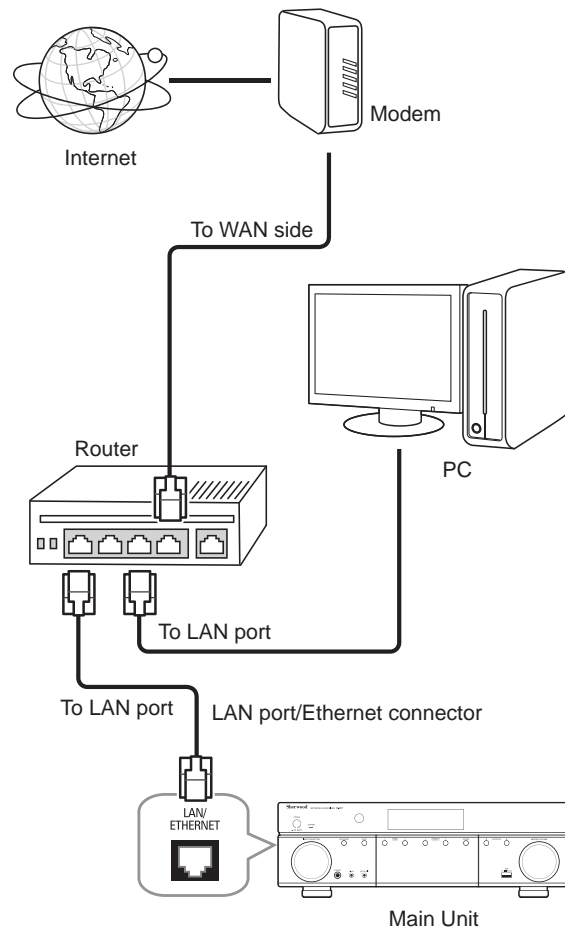

Note

- After making a broadband internet connection, you should set the communication settings. For details, see "Network Setup" on page 49.
- When using a broadband internet connection, a contract with an internet service provider is required. For more information, contact local internet service provider.
- Since the connected equipment and connection method may differ depending on your internet environment, refer to the operating instructions of the equipment.

Connecting an Antenna

To listen to radio stations, connect the FM wire antenna and AM loop antenna as illustrated below.

Connecting FM Antenna

To strengthen the signal reception, extend the antenna to its full length.

Indoor Antenna

- 1 Connect the FM indoor antenna to the FM antenna terminal.
- 2 Change the position of the antenna until you get the best reception of your favorite FM stations.

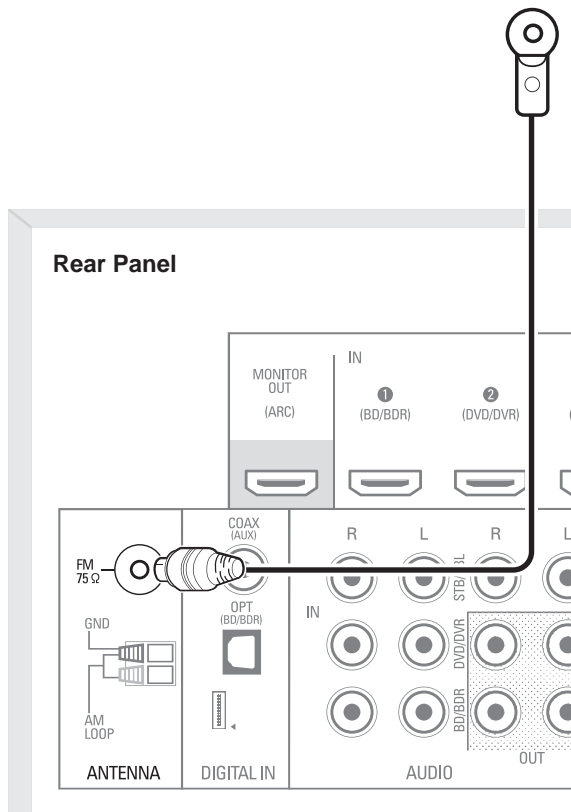

Outdoor Antenna

- 1 Remove the indoor antenna if it is connected.
- 2 Connect the FM outdoor antenna to the FM antenna terminal.

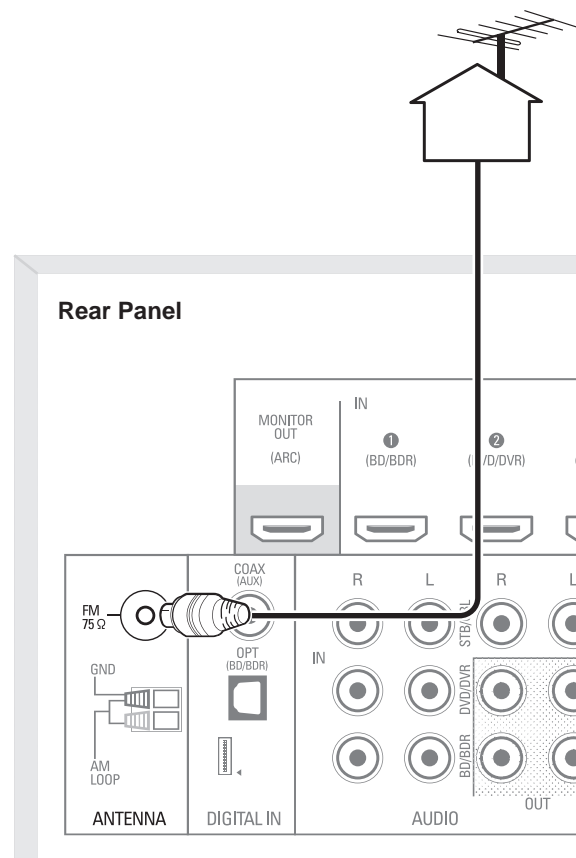

R-807 NETWORK AV RECEIVER

Connecting AM Antenna

- 1 Assemble the AM loop antenna as illustrated below.
- 2 Place the antenna as far as possible from the main unit, TV set, speaker cords and the AC input cord, and set the direction for the best reception.
- 3 If the reception is poor with the AM loop antenna, it is recommended to replace it with an AM outdoor antenna.

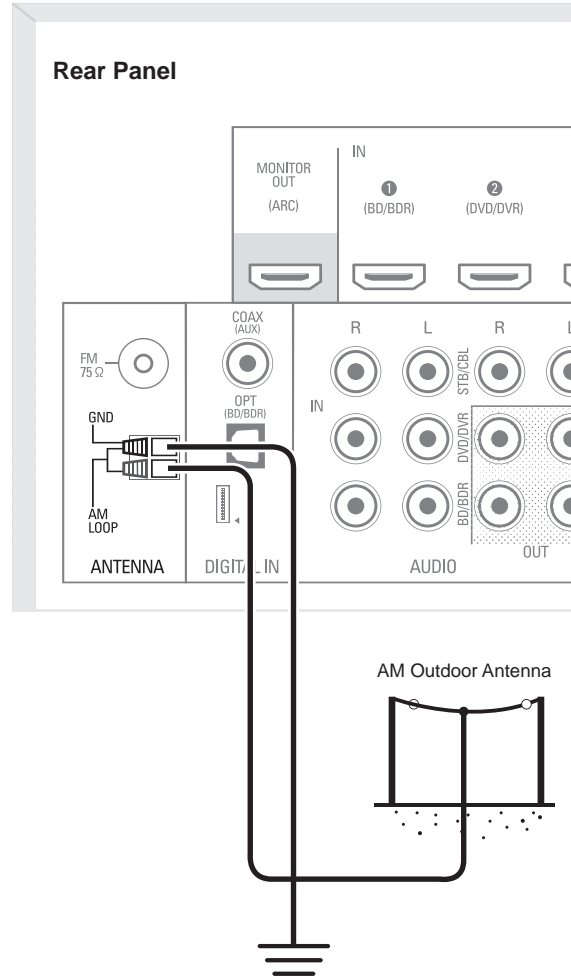
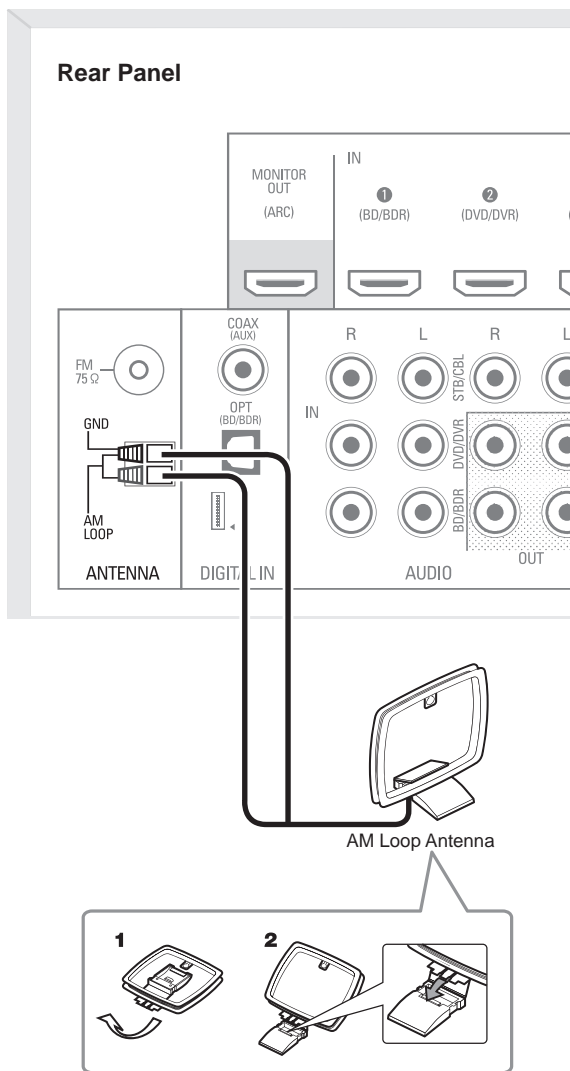

Connecting to Muti-Room

The multi-zone function allows you to play back different input sources in the room where the unit is installed (Main Room) and in another room (Room2).

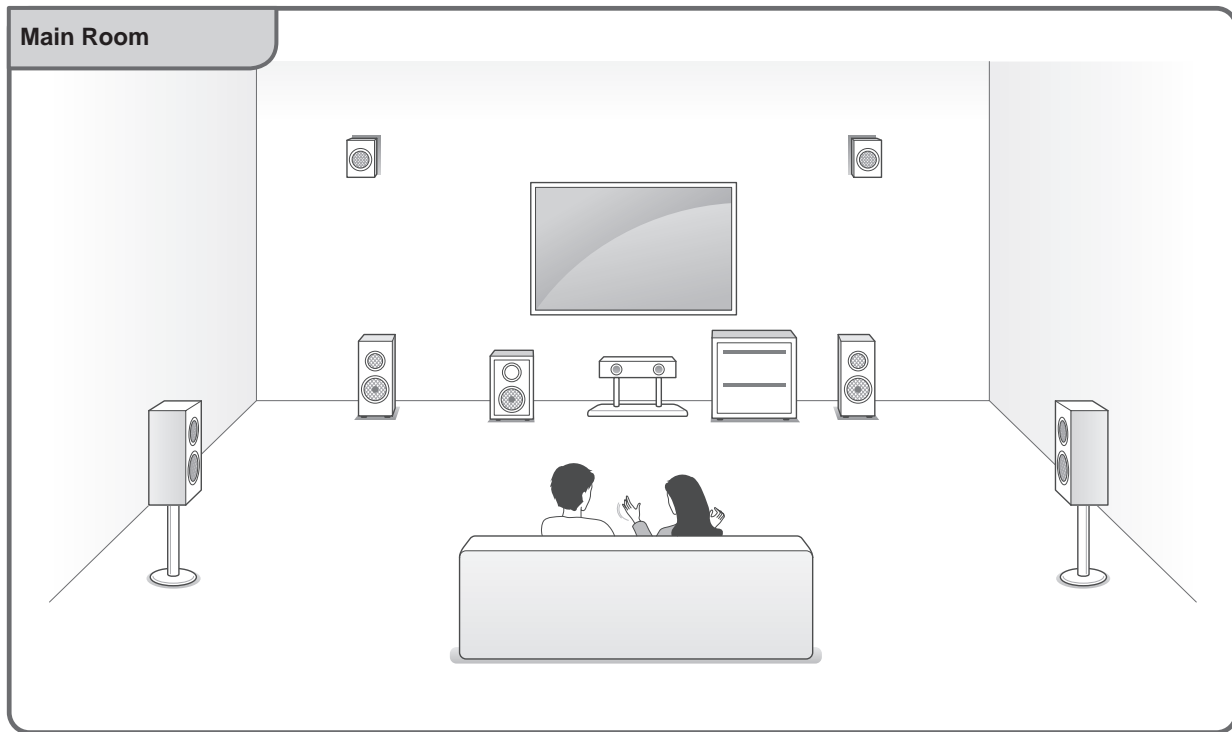

You can enjoy sounds from the equipment connected to the main unit in a room other than the main room. For example, you can watch the DVD in the main room and listen to a CD in the sub room. The main unit can power up to two independent systems in separate rooms after you have made the proper multi-room connections. Different sources can play in two rooms at the same time or, depending on your needs, the same source can also be used. The main and sub room have independent power (the main room power can be off while sub room is on) and the sub room can be controlled by the remote control.

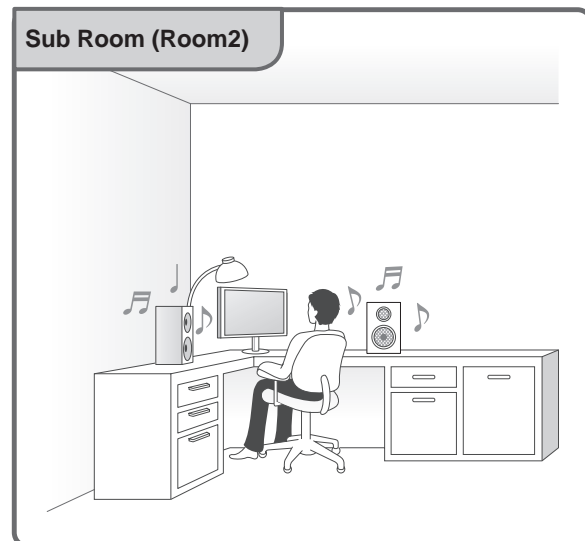

Note

- When the Room2 output is enabled, the surround back speakers in the main room do not produce sound.
- Remove the unit's power cable from the AC wall outlet before connecting speakers or an external amplifier.

R-807 NETWORK AV RECEIVER

Connecting to the System's Internal Amplifier

Connect the speakers placed in Room2 to the main unit with speaker cables.

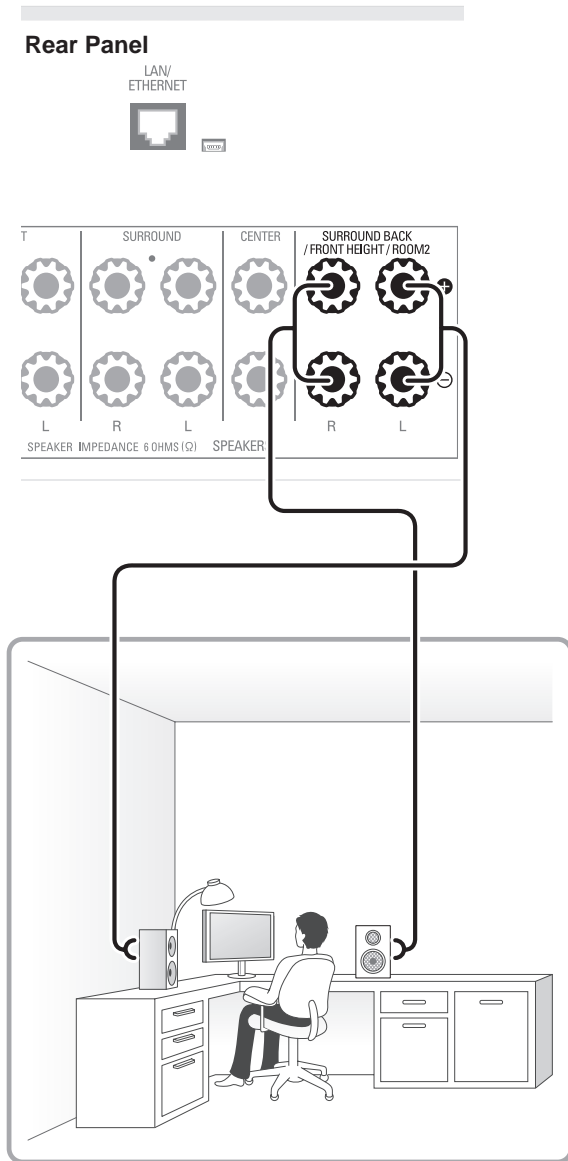

Connecting to an External Amplifier

Connect the external amplifier (with volume control) placed in Room2 to the main unit with analogue audio cable.

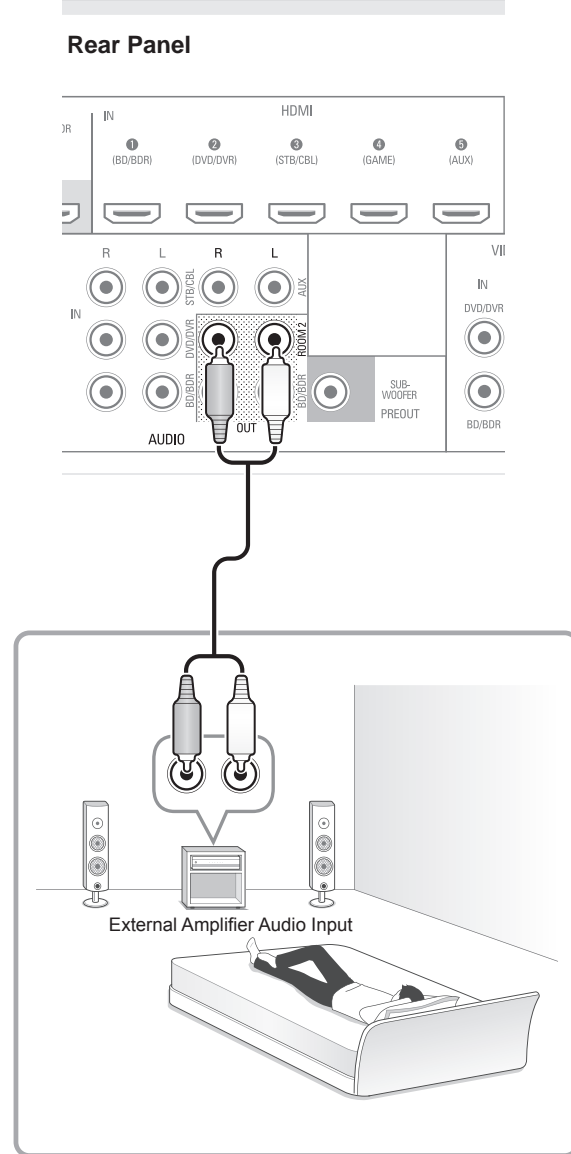

Controlling Room2

Connect the external amplifier (with volume control) placed in Room2 to the unit with analogue audio cable. You can select different sources for main room and second room (ROOM 2) and play them at the same time.

- 1 Press **ROOM2** on the remote control.
 - The ROOM 2 indicator is displayed on the fluorescent display.



- 2 Press the ROOM2 input select button to select the desired mode.

- Each time the button on the universal remote control is pressed, the input source changes in the following order:
DVD → STB → AUX → F.AUX → TUNER



Note

- If you press the ROOM 2 INPUT SELECTOR button when the ROOM 2 function is off, it is automatically turned on.

- 3 Adjust the ROOM 2 volume by pressing the ROOM 2 VOLUME UP(+)/DOWN(-) buttons.



- 4 Adjust the tone (bass and treble) for ROOM 2 source.

- The tone level can be adjusted within the range of -10 ~ +10 dB.
- In general, we recommend the bass and treble to be adjusted to 0 dB (flat level).

Caution

- Extreme settings at high volume may damage your speakers.

- 5 Use the remote's left and right arrow buttons to select OFF, SMALL or LARGE for the Front, Center and Surround speaker positions, depending on the speakers you have connected to the receiver.

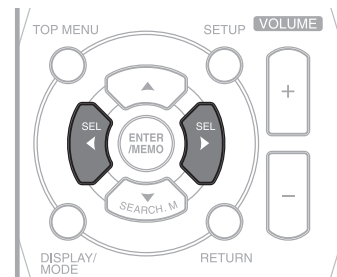

Connecting Power

Make sure to plug in only after you have connected all your components to the main unit. Plug the supplied AC input cord into the AC inlet and then into the wall outlet.

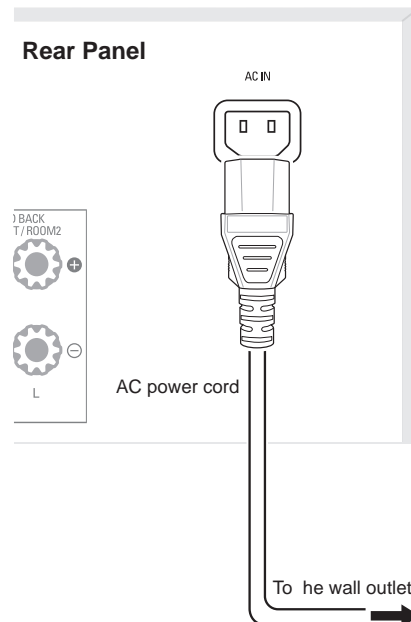

Operating Your System

Listening to Your System

Basic Operation

You can listen to audio by following the basic procedures below.

- 1 Turn on the connected component.
- 2 Turn on the main unit.
 - On the main unit, press **POWER** and **ON/STANDBY**.
 - On the remote control, press **POWER ON** and **STANDBY**.

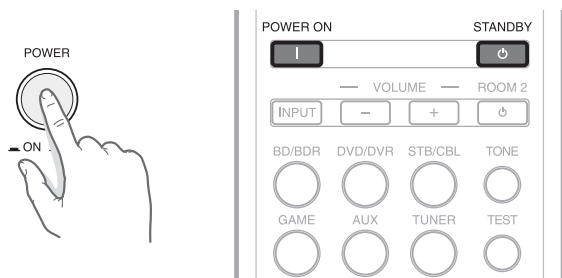

Note

- When the power button is pressed on the main unit, you cannot turn on the main unit by pressing the power button on the remote control.

- 3 Select the input source you want to play back.
 - On the main unit, rotate **INPUT SELECTOR**.
 - Each time the button is pressed, the display changes in the following order:
BD/BDR → DVD/DVR → STB/CBL → GAME → AUX → NETWORK → USB → TV → F.AUX → TUNER
 - On the remote control, press a source select button.

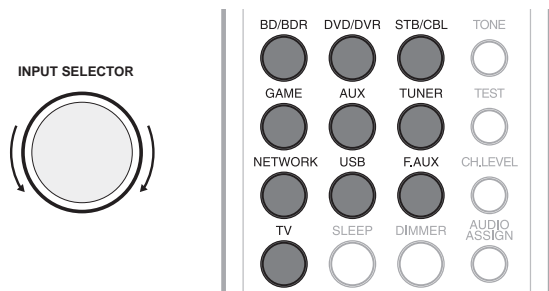

- 4 Start playback of the component you selected in step 1.
- 5 During playback, you can adjust the volume level.
 - On the main unit, rotate the volume controller.
 - On the remote control, press **VOLUME +/-**.

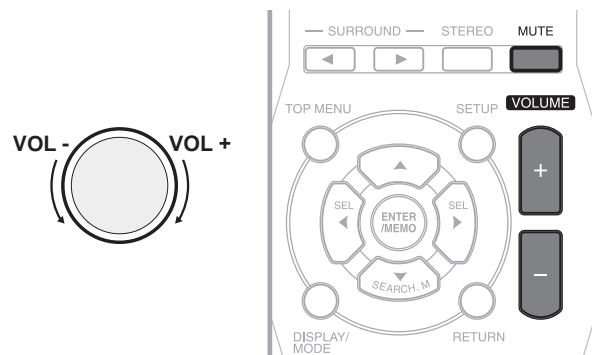

Muting the Sound

You can mute the sound temporarily by pressing **MUTE**.

- 1 Press **MUTE** to mute the sound.

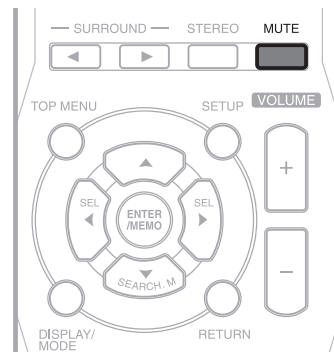

- 2 Press **MUTE** or **VOLUME +/-** to turn on the sound.

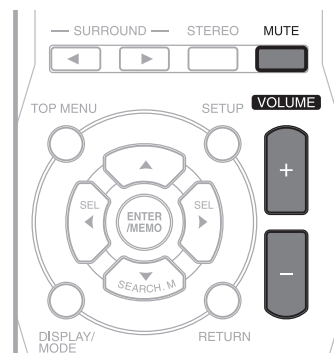

Enjoying Surround Effects

This main unit incorporates a sophisticated Digital Signal Processor that allows you to create optimum sound quality and sound atmosphere in your personal Home Theater.

Setting the Surround Mode

Before surround playback, first perform the speaker setup procedure, etc. on the OSD settings for optimum performance. For details, see “Setting the Speaker Setup” on page 44.

1 Select the desired surround mode by pressing the **SURROUND** buttons.

- Each time the buttons are pressed, the surround mode changes depending on the input signal format as the table below:

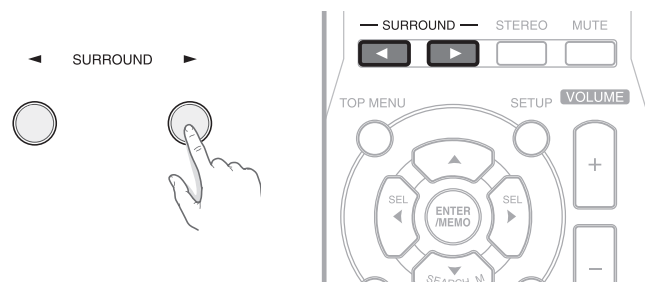

Signal format being input	Selectable surround mode
Dolby Digital Plus sources	DOLBY DIGITAL PLUS
Dolby TrueHD sources	DOLBY TRUEHD
Dolby Digital EX 6.1 channel sources Dolby Digital 5.1 channel sources	<DOLBY DIGITAL EX, DOLBY D + PLIIx MUSIC>, (DOLBY D + PLIIx MOVIE), {DOLBY D + PLIIz}, DOLBY DIGITAL, DSP Surround modes*
Dolby Digital 2 channel sources	<DOLBY PLIIx MOVIE, DOLBY PLIIx MUSIC, DOLBY PLIIx GAME>, [DOLBY PLII MOVIE, DOLBY PLII MUSIC, DOLBY PLII GAME], {DOLBY PLIIz HEIGHT}, DTS NEO: 6 MUSIC, DTS NEO: 6 CINEMA, DSP Surround modes*
DTS-HD High Resolution Audio sources	DTS-HD HRA
DTS-HD Master Audio sources	DTS-HD MSTR
DTS ES Discrete/Matrix 6.1 channel sources	<Corresponding DTS ES mode, DTS + PLIIx MUSIC>, (DTS + PLIIx MOVIE), DTS, {DTS + PLIIz}, DSP Surround modes*
DTS sources DTS 96/24 sources	Corresponding DTS mode, <DTS + NEO: 6, DTS + PLIIx MUSIC>, (DTS + PLIIx MOVIE), DTS, {DTS + PLIIz}, DSP Surround modes*
PCM (multi-channel) sources **	MULTI PCM, <MCH + PLIIx MOVIE, MCH + PLIIx MUSIC>, {MCH + PLIIz}, DSP Surround modes*
PCM (2 channel) sources Analog stereo sources Music files from USB	<DOLBY PLIIx MOVIE, DOLBY PLIIx MUSIC, DOLBY PLIIx GAME>, [DOLBY PLII MOVIE, DOLBY PLII MUSIC, DOLBY PLII GAME], DTS NEO: 6 MUSIC, DTS NEO: 6 CINEMA, {DOLBY PLIIz HEIGHT}, DSP Surround modes*

Depending on surround back speaker setting, some surround modes can be selected or not as follows:

- < > : Possible only when surround back speaker is not set to “NO”.
- [] : Possible only when surround back speaker is set to “NO”.
- () : Possible only when surround back speaker is set to “2ch”.
- { } : Possible only when front height speaker is set to “ON”.
- * : Stand for THEATER, MOVIE, HALL, GAME, STADIUM, MCH STEREO, ALC.
- ** : on the signal format being input, the Do by Pro Logic IIx modes may not be selected.

R-807 NETWORK AV RECEIVER

DTS Digital Surround

DTS Digital Surround (also called simply DTS) supports up to 5.1 discrete channels and uses less compression for high fidelity reproduction. Use it with DVDs and CDs bearing the DTS logo.

DTS-ES™ Discrete 6.1

This is a 6.1 channel discrete digital audio format which adds a surround back channel to the DTS digital surround sound. The seven totally separate audio channels provide better spatial imaging and 360 degrees sound localization, perfect for sounds that pan across the surround channels. Use it with DVDs bearing the DTS-ES logo, especially those with a DTS ES Discrete sound track.

DTS - ES™ Matrix 6.1

This is a 6.1 channel discrete digital audio format inserting a surround back channel to the DTS digital surround sound through matrix encoding. Use it with DVDs bearing the DTS-ES logo.

DTS Neo: 6™ Surround

DTS Neo: 6 is a matrix decoding technology for achieving 7.1 channel surround playback with 2 channel sources. It includes 'DTS Neo: 6 Cinema' suited for playing movies' and 'DTS Neo: 6 Music' suited for playing music'.

DTS 96/24

This is high resolution DTS with a 96 kHz sampling rate and 24 bit resolution, providing superior fidelity. Use it with DVDs bearing the DTS 96/24 logo.

DTS-HD High Resolution Audio

Developed for use with HDTV, including the new video disc formats Blu-ray and HD DVD, this is the latest multi-channel audio format from DTS. It supports up to 7.1 channels with 96 kHz/24 bit sampling rate and signal resolution.

DTS-HD Master Audio

Designed to take full advantage of the additional storage space offered by the new Blu-ray and HD DVD disc formats, this new DTS format offers up to 7.1 discrete channels of uncompressed digital audio with 96 kHz/24 bit sampling rate and signal resolution.

Manufactured under license under U.S. Patent Nos: 5,956,674; 5,974,380; 6,226,616; 6,487,535; 7,212,872; 7,333,929; 7,392,195; 7,272,567 & other U.S. and worldwide patents issued & pending. DTS-HD, the Symbol, & DTS-HD and the Symbol together are registered trademarks & DTS-HD Master Audio is a trademark of DTS, Inc. Product includes software. © DTS, Inc. All Rights Reserved.

Dolby Digital

Dolby Digital is the multi-channel digital signal format developed by Dolby Laboratories. Discs bearing the Dolby Digital logo include the recording of up to 5.1 channels of digital signals. This will put you right in the middle of the action, just like being in a movie theater or concert hall.

Dolby Digital EX

This mode expands 5.1-channel sources for 6.1/7.1 channel playback. It's especially suited to Dolby Digital EX soundtracks that include a matrix-encoded surround back channel. The additional channel adds an extra dimension and provides an enveloping surround sound experience, perfect for rotating and fly-by sound effects.

Dolby Digital Plus

Developed for use with HDTV, including the new video disc formats Blu-ray and HD DVD, this is the latest multichannel audio format from Dolby. It supports up to 7.1 channels with 48 kHz/24-bit sampling rate and signal resolution.

Dolby TrueHD

Designed to take full advantage of the additional storage space offered by the new Blu-ray and HD DVD disc formats, this new Dolby format offers up to 7.1 discrete channels of lossless audio performance with 96 kHz/24 bit sampling rate and signal resolution.

Dolby Pro Logic IIz

This mode adds front height channels to surround sound, creating a 7.1 channel playback for music, movies and video games. Dolby Pro Logic IIz brings enhanced spatial effects, added depth, and an overall airiness to listening experience.

Dolby Pro Logic IIx

This mode expands any 2-channel source for 7.1-channel playback. It provides a very natural and seamless surround sound experience that fully envelopes the listener. As well as music and movies, video games can also benefit from the dramatic spatial effects and vivid imaging. It includes 'Dolby Pro Logic IIx Movie' suited for playing movies, 'Dolby Pro Logic IIx Music' suited for playing music and 'Dolby Pro Logic IIx Game' suited for playing games.

Dolby Pro Logic II

If you are not using any surround back speakers, Dolby Pro Logic II surround will be used instead of Dolby Pro Logic IIx surround. It includes Dolby Pro Logic II Movie, Dolby Pro Logic II Music and Dolby Pro Logic II Game like Dolby Pro Logic IIx surround.

Manufactured under license from Dolby Laboratories. Dolby, Pro Logic, and the double-D symbol are registered trademarks of Dolby Laboratories.

Theater

This mode provides the effect of being in a theater when watching a play.

Movie

This mode provides the effect of being in a movie theater when watching a movie.

Hall

This mode provides the ambience of a concert hall for classical music sources such as orchestral, chamber music or an instrumental solo.

Game

This mode is suitable for video games.

Stadium

This mode provides an expansive sound field in order to achieve a true stadium effect when watching baseball or soccer games.

Multi Channel Stereo

This mode is designed for playing background music. The front, surround and surround back channels create a stereo image that encompasses the entire area.

ALC (Auto Volume Level Control)

This mode automatically equalizes playback sound levels if each sound level varies with the music source recorded in a portable audio player.

- The sound from each channel can be reproduced according to the surround modes as follows:

Modes \ Channels	FRONT L/R	CENTER	SURROUND L/R	SURROUND BACK/FRONT HEIGHT L/R	SUBWOOFER
DTS-HD HIGH RESOLUTION AUDIO/MASTER AUDIO	○	○	○	○/-	○
DTS, DTS 96/24	○	○	○	-	○
DTS ES DISCRETE/MATRIX	○	○	○	○	○
DTS NEO: 6 CINEMA/MUSIC	○	○	○	○	- (*)
DOLBY DIGITAL PLUS/DOLBY TRUEHD	○	○	○	○/-	○
DOLBY DIGITAL	○	○	○	-	○
DOLBY DIGITAL EX	○	○	○	○	○
DOLBY PRO LOGIC IIz HEIGHT	○	○	○	○	○
DOLBY PRO LOGIC IIx MOVIE/MUSIC/GAME	○	○	○	○	○
DOLBY PRO LOGIC II MOVIE/MUSIC/GAME	○	○	○	-	○
(MULTI) PCM	○	○	○	○/-	○
AUTO VOLUME LEVEL CONTROL	○	-	-	-	- (*)
Other Surrounds	○	○	○	○	- (*)
STEREO	○	-	-	-	- (*)

(*): Depending on the subwoofer setting, the sound from the subwoofer channel may be reproduced.

- Depending on the speaker settings and the number of the encoded channels, etc., the sound from the corresponding channels may not be reproduced. For details, see "Setting the Speaker" on page 44.

Canceling the Surround Mode for Stereo Operation

- 1 Press **STEREO**.
 - Depending on the input signal format, either the stereo mode or the 2CH downmix mode is selected.

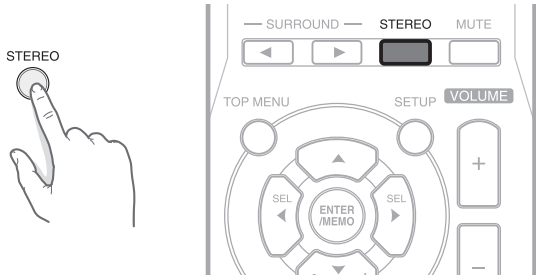

- 2 To cancel either the stereo mode or the 2CH downmix mode, press the **SURROUND** buttons to select the surround mode.

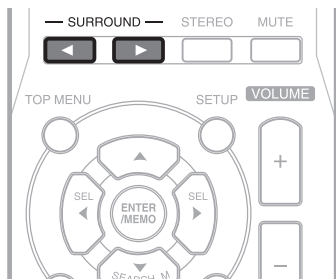

Note

- 2 CH downmix mode allows the multi-channel signals encoded in DTS or Dolby Digital format, etc. to be mixed down into 2 front channels and to be reproduced through only two front speakers or through headphones.
- If headphones are plugged in to the main unit while playing the multi-channel digital signals from DTS or Dolby Digital sources, etc., it will enter the 2CH downmix mode automatically.

Adjusting the Current Channel Level

After adjusting each channel level with test tone, adjust the channel levels according to the program sources or to suit your tastes.

- 1 Press the **CHANNEL LEVEL** button.

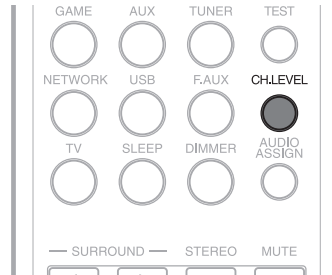

- 2 Select the desired channel by pressing **▲** or **▼**.

- Each time the buttons are pressed, the corresponding channel changes as follows:

FL [→ FHL] → C [→ FHR] → FR →
SR (→ SBR → SBL) → SL → SW

() : Possible when the surround back channel is set to "2ch" or "1ch".

[] : Possible only when the front height speaker is not set to "NO".

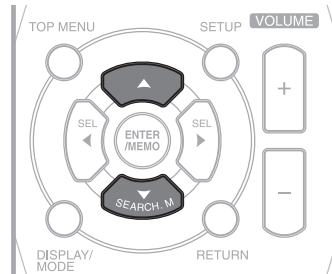

Note

- Depending on the speaker settings (such as "NO") and surround mode, some channels cannot be selected.

- 3 Adjust the level of the selected channel as desired by pressing **◀** or **▶**.

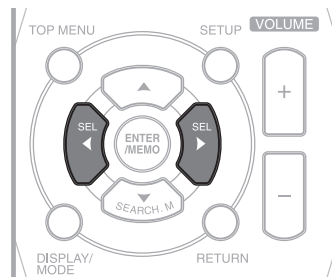

- 4 Repeat the steps 2 and 3 to adjust each channel level.

Listening to Music on USB

You can play audio files from a USB device.
However, editing or copying a data file is not possible.

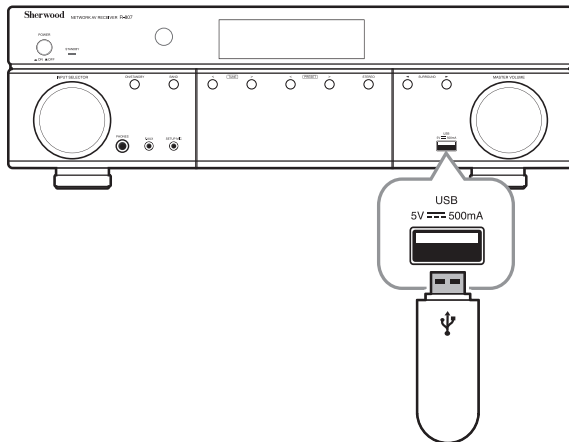

USB storage device



Note

- The USB jack does not support the connection of other USB devices except for a USB flash drive or a USB memory card reader.
- When the USB device does not fit into the USB jack, a USB extension cable is required.
- You can play back only the content from a connected USB device.
- Copy-protected contents are not playable.

To Stop Playback

- 1 During playback, press ■.

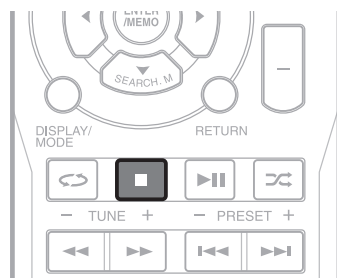

- 2 To resume playback, press ►||.

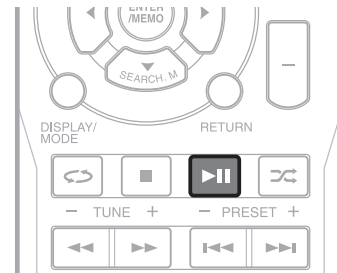

To Pause Playback

- 1 During playback, press ►||.
 - Playback will stop at the point where the button is pressed.
 - To resume playback from this point, press the button again.

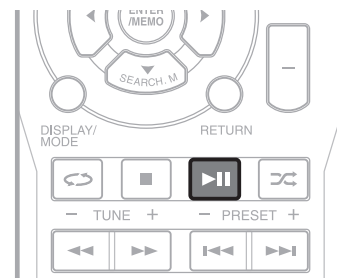

To Skip Forward or Backward

- 1 During playback, press ◀◀ or ▶▶.
 - Each time the button is pressed, a track is skipped forward or backward.

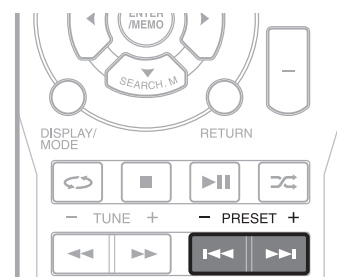

To Play Repeatedly

- 1 During playback, press **REPEAT**.
Each time the button is pressed, repeat mode changes as follows:
 - **RPT ONE**
Repeats the currently playing music file.
 - **RPT ALL**
Repeats all music files.
 - **RPT FLDI**
Repeats all music files in the folder.

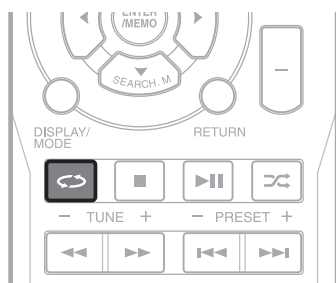

To Play Randomly

- 1 During playback, press **RANDOM**.
 - "SFL ON" is displayed on the display panel.
 - All music files in the folder are played in random order.

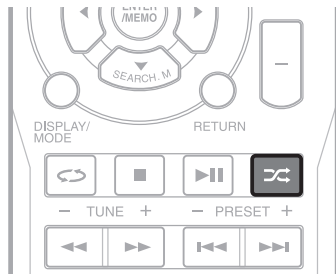

- 2 To cancel random playback, press **RANDOM** again.
 - "SFL OFF" is displayed on the display panel.



Note

- You can only use the skip mode, repeat mode and random mode when playing music files stored on a USB memory device.

Listening to Internet Radio

You can listen to Internet radio broadcasts provided by vTuner. You can control the internet radio with the menu displayed on the TV screen.

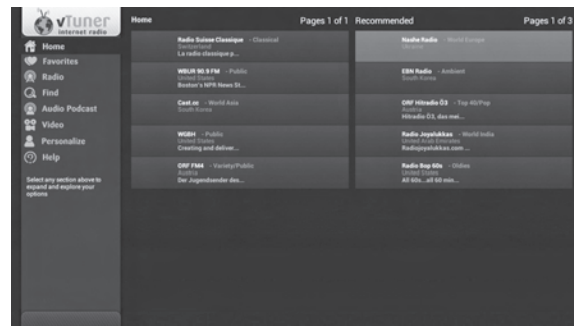

- 1 Select **NETWORK** as an input source.
 - On the main unit, rotate **INPUT SELECTOR**.
 - On the remote control, press **NETWORK**.

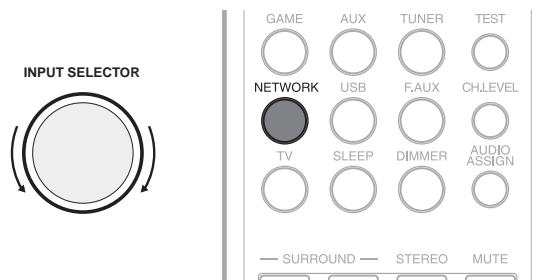

- 2 When the image is displayed as below, select **Internet Radio** on the screen, and then press **ENTER** on the remote control.



- 3 Select the desired category by pressing ▲ and ▼, then press **ENTER** on the remote control.

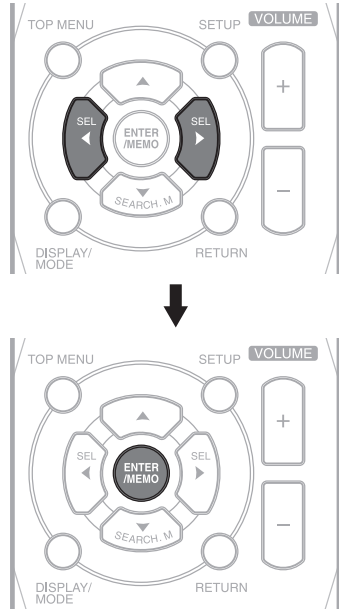

Note

- To use this function, the unit should be connected to the internet. Refer to “Network Settings” on page 49 for details.
- The service may be discontinued without notice.
- You may not be able to receive some internet radio stations.

Listening to Music from the Media Server

You can play music files stored on a computer (media server) connected to this receiver via a wired or wireless network. You can share the music files easily by using Windows Media Player 11 or later versions.

Configuring the Windows Media Player

On Windows Media Player 11 version

- 1 Run the Windows Media Player 11 version on your computer.
- 2 Click the “Library” tab in the menu bar, and then select “Media Sharing”.
- 3 In the “Media Sharing” dialog box, select the “Share my media” check box, and then click “OK”.
- 4 Select this receiver in the list of devices, and then click “Allow”.
- 5 Click “OK” to close the dialog box.

On Windows Media Player 12 version

- 1 Run the Windows Media Player 12 version on your computer.
- 2 Click “Stream” at the top of the player.
- 3 Click “Turn on media streaming” when it appears in the next window.
- 4 Select “Local Network” next to Show devices on if it is not already selected.
- 5 Click “OK” to close the dialog box.



Note

- Windows Media Player 11 and 12 versions can be downloaded for free from the Microsoft web site.
- If the firewall restricts access, Windows Media Player 11 and 12 cannot be configured.

R-807 NETWORK AV RECEIVER

Listening to Music from the Media Server

- 1 Start your computer.
- 2 Select **NETWORK** as an input source.
 - On the main unit, rotate **INPUT SELECTOR**.
 - On the remote control, press **NETWORK**.

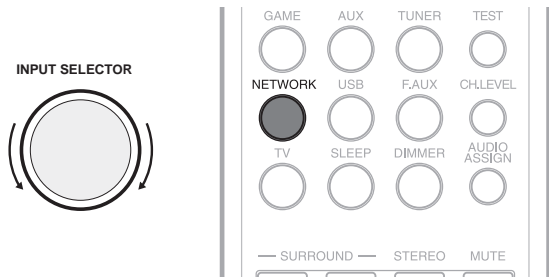

- 3 Select **Media Server** on the screen, and then press **ENTER** on the remote control.



- 4 Select the desired category by pressing ◀ and ▶, then press **ENTER** on the remote control.

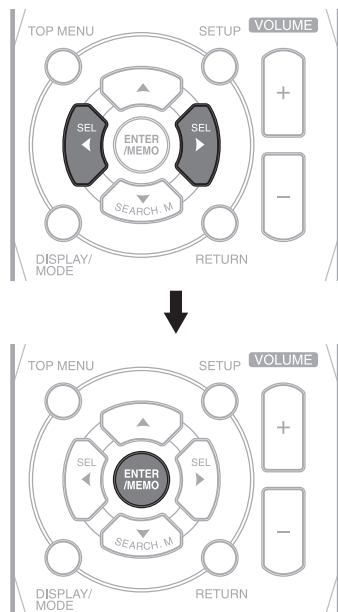

- 5 Repeat step 3 above until the desired music file is selected.
The playback functions are the same as those for USB. Refer to ** for details on playback.

Using the Sherwood Remote Application

Preparing for the Application

Setting the Network on the System

- 1 Select **NETWORK** as an input source.
 - On the main unit, rotate **INPUT SELECTOR**.
 - On the remote control, press **NETWORK**.

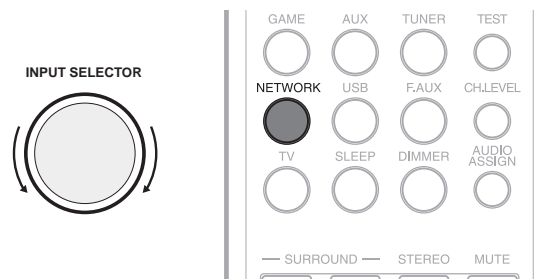

- 2 Press **SETUP** on the remote control.

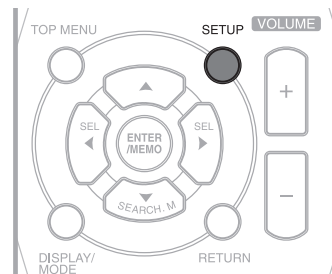

- 3 Tap **Hotspot & Wi-Fi Direct > Soft Wi-Fi hotspot** or **Wi-Fi direct**.

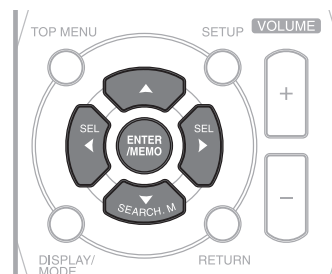

Note

- Wi-Fi hotspot is enabled as a default connection setting.

Installing the Application on Your Phone

- 1 Visit **Play Store** on your Android Smartphone. Or visit **AppStore** on your iPhone.
- 2 Search for **Sherwood Remote**.
- 3 Download and install the application on your phone.
- 4 Open the application.
- 5 Tap **Select Product** and **R-807**.

Connecting Your Phone with the System

• **On a Android phone**

- 1 Go to Wireless & networks settings in your Android smartphone.
- 2 Enable Wi-Fi direct or Portable Wi-Fi hotspot.
 - When you connect your phone with the main unit using a Wi-Fi hotspot, you should enter the password (1234567890) for the system connection.
- 3 Go to Wi-Fi settings to select and tap **R-807** and **Connect**.

Note

- When Ethernet is not connected to the main unit, you cannot use Wi-Fi connection even though Wi-Fi hotspot is enabled on your phone.

• **On an iPhone**

- 1 Go to Wi-Fi hotspot settings to select and tap **R-807**.

Using the Application

The Sherwood Remote application helps you to control the main unit remotely by allowing you to select input source, to set a surround mode, to control Room2, and use Wiink.

- 1 Open the Sherwood Remote application.
- 2 When the product search window is activated, select and tap R-807. Then, you can use your smartphone as a remote control for the main unit.



Note

When a network error occurs, the following screen will pop up.

The screenshot shows a 'Network Error!' dialog box. The text inside says: 'Please check your network connection or turn on the Network Standby setting on the product setup menu.' Below the text are three buttons: 'Select Product', 'Demo Mode', and 'Retry'.

- **Select Product:** Check your smartphone network connection, and select R-807 again.
- **Demo Mode:** Uses the application in Demo Mode.
- **Retry:** Tries to open the application again.

R-807 NETWORK AV RECEIVER

Overview of the Main Screen

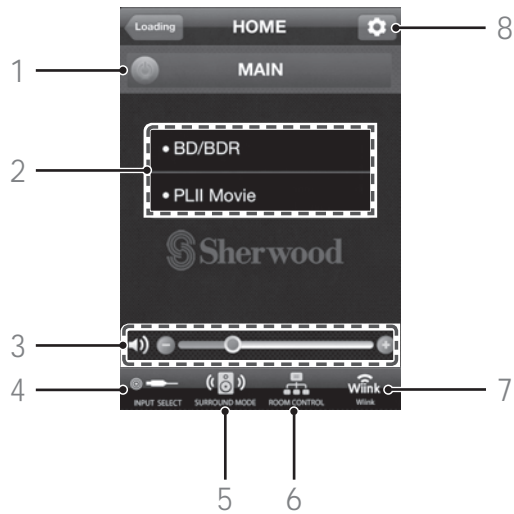

No.	Description
1	Turns on or off the main unit <ul style="list-style-type: none"> To activates the function, you should set N.S.C to ON. If you set the function on, the power consumption may increase.
2	Selected input source Surround mode
3	Volume control bar
4	Selects input source
5	Selects surround mode
6	Controls Room2
7	Wiink (Direct AV, Internet Radio, Media Server)
8	Settings

Using Direct AV

On Direct AV, you can listen to songs, watch videos, and view photos stored on your Android phone or iPhone.

- 1 Tap **Wiink** at the bottom of the phone screen. Or tap **INPUT SELECT** and select and tap **NETWORK**.
- 2 Tap **Direct AV**.



- 3 Tap **Audio** to listen to the songs stored on your phone.
Tap **Video** to watch video stored on your phone.
Tap **Photo** to view photos stored on your phone.
 - **iOS**



• Android



Listening to Songs on Your Smartphone

You can select a song on the song list and play it over the main unit.



No.	Description
1	Moves to the previous menu • This menu is not displayed on Android smartphone.
2	Plays or pauses a song
3	Plays a previous song
4	Sets shuffle function
5	Volume control bar
6	Sets the repeat function (Repeat for all song or one song)
7	Plays the next song
8	Progress bar

Watching Videos on Your Smartphone

You can select a video on the video file list and enjoy it on the main unit.



No.	Description
1	Moves to the previous menu • This menu is not displayed on the Android smartphone.
2	Plays or pauses a video
3	Moves to a previous video
4	Volume control bar
5	Moves to the next video
6	Controls display size
7	Progress bar

R-807 NETWORK AV RECEIVER

Viewing Photos on Your Smartphone

You can view photos as a slideshow and set the slideshow transition time at 10, 20, or 30 seconds.



No.	Description
1	Moves to the previous menu • This menu is not displayed on the Android smartphone.
2	Starts the photo slideshow.
3	Sets the slideshow transition time.

Using Internet Radio and Media Server

You can use your smartphone as a remote controller for Internet Radio and Media Server.

- 1 Tap **Wiink** at the bottom of the phone screen.
- 2 Tap **Internet Radio** or **Media Server**.

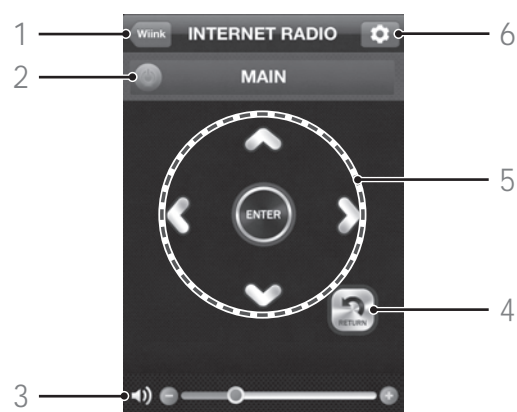

No.	Description
1	Moves to the previous menu • This menu is not displayed on the Android smartphone.
2	Turns off the main unit.
3	Volume control bar.
4	Returns to the previous menu.
5	Selects or confirms a broadcast in Internet Radio and Media server.
6	Moves to the settings menu.

Listening to FM Radio

Auto Tuning

- 1 Press **TUNE +** or **TUNE -** for more than 2 seconds.
 - The tuner keeps searching until a station with strong signal strength is found. The display shows the tuned frequency.
 - If the found station is not the desired one, simply repeat this operation.
 - Stations with weak signal strength are skipped during auto tuning.

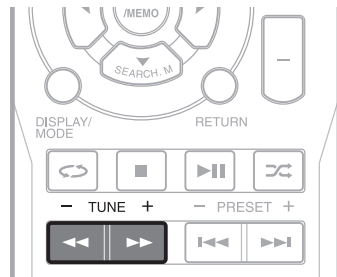

Manual Tuning

- 1 Press **TUNE +** or **TUNE -** repeatedly until the desired station is found.

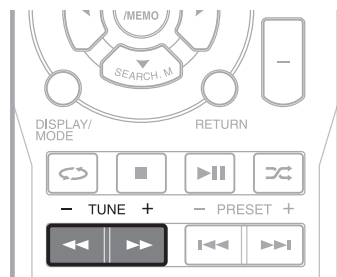

Manual Presetting

- 1 Tune to the desired station with auto or manual tuning.
- 2 Press **ENTER/MEMO**.
 - A preset number blinks.

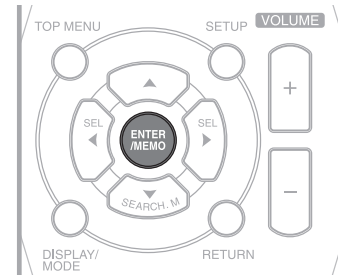

- 3 Select a desired preset number (1~30) by pressing **TUNE +** or **TUNE -**.
 - A station has now been stored in the memory.
 - A stored station is erased from the memory by storing another station in its place.

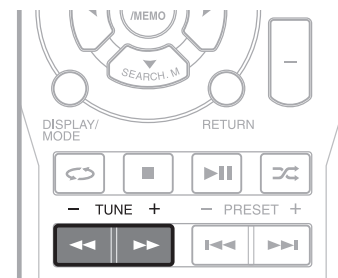

- 4 Press **ENTER/MEMO** again to confirm your selection.
 - The station has now been stored in the memory.
 - A stored station is erased from the memory by storing another station in its place.

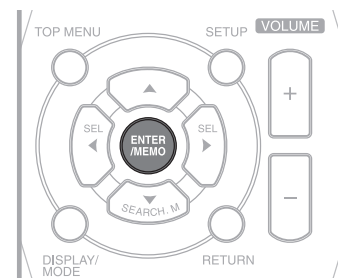

- 5 Repeat the above steps 1 - 4 to store another station.

Auto Presetting

- 1 Press and hold down **ENTER/MEMO** for more than 2 seconds.
 - “AUTO MEMORY” blinks and the main unit begins to preset stations with strong signals.
 - Up to 30 FM stations may be stored.
 - To stop auto presetting, press **ENTER/MEMO** again.

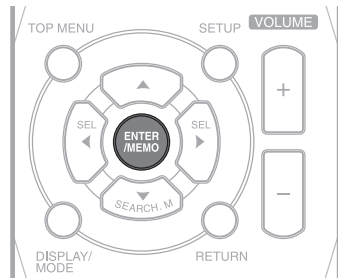

Note

- FM stations with weak signal strength cannot be stored to memory.

Tuning in to Preset Stations

- 1 Select **FM TUNER** as the input source.
- 2 Select a desired preset number by pressing **PRESET -** or **PRESET +**.

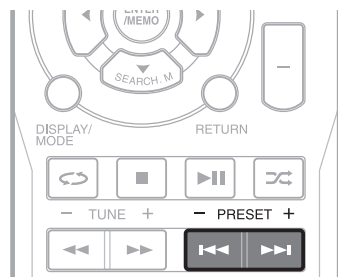

RDS Tuning

RDS (Radio Data System) is a way of sending information signals along with transmitter signals. Your tuner is capable of translating these signals and displaying the information.

These codes contain the following information: Program Service name (PS), A list of Program Types (PTY), Traffic Announcement (TA), Radio Text (RT).



Note

- In some countries, RDS tuner function may not be available.

PTY search

Use this function to automatically search and receive stations broadcasting a desired type of program.

- 1 In the FM mode, select the PTY search mode in the following order:
 - “PTY SEARCH (PTY NAME)” is displayed.

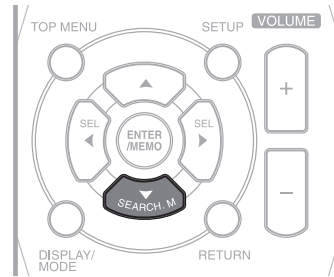

- 2 Press **◀** or **▶** and **ENTER/MEMO** to select a program type.
 - Each time these buttons are pressed, one of 29 different types of programs is selected. (NEWS, AFFAIRS, INFO, SPORT, EDUCATE, DRAMA, CULTURE, SCIENCE, VARIED, POP M, ROCK M, EASY M, LIGHT M, CLASSICS, OTHER M, WEATHER, FINANCE, CHILDREN, SOCIAL, RELIGION, PHONE IN, TRAVEL, LEISURE, JAZZ, COUNTRY, NATION M, OLDIES, FOLK M, DOCUMENT)
 - When “PTY SEARCH (PTY NAME)” is not displayed, repeat from step 1.

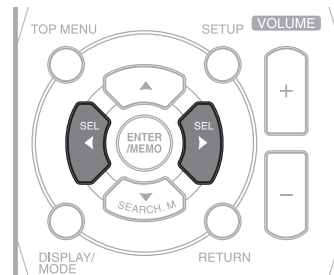

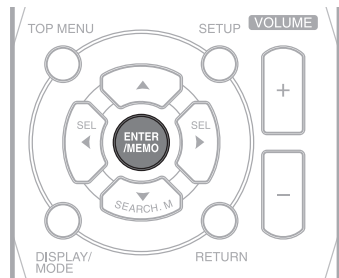

- 3 While a desired program type is displayed:
 - The tuner automatically seeks a station offering PTY services.
 - If no station is found, "NO PTY" is displayed.

Displaying RDS information

- 1 Press **DISPLAY**.

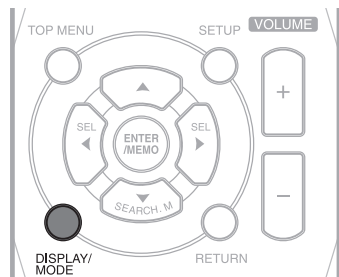

- Each time this button is pressed, display mode changes in the following order:
 - Function → Surround Mode → Volume → Radio Text(RT) → Program Service Name(PS) → Program Type (PTY) → Frequency →
- **Program Service Name(PS)**
The name of the radio station.
- **Program Type(PTY)**
This indicates the kind of program currently being broadcast.
- **Radio Text(RT)**
Messages sent by the radio station. For example, a talk show radio station may provide a phone number as RT.
- If signals are too weak or no RDS service is available, "NO NAME", "NO PTY" or "NO TEXT" will be displayed.

Recording

You can make an audio or a video recording from the built-in tuner, or from an audio or video source connected to the receiver (such as a CD player or TV). Keep in mind you can't make a digital recording from an analog source or vice-versa, so make sure the components you are recording to/from are hooked up in the same way. (For details on connection, see "Connecting Playback Components" on page 17.)

- The receiver's volume, Audio parameters (the tone controls, for example), and surround effects have no effect on the recorded signal.
- Some digital sources are copy-protected, and can only be recorded in analog.
- Some video sources are copy-protected. These cannot be recorded.

- 1 Select the desired recording source.

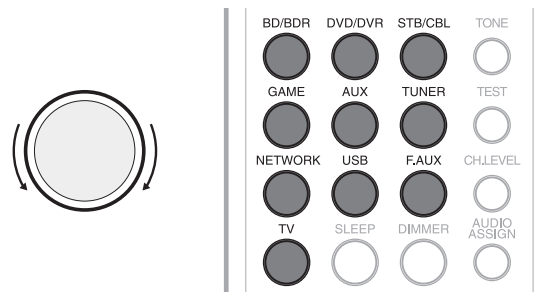

- 2 Start recording on the component.
- 3 Start play on the desired input.
 - The audio and video signals from the desired input will be dubbed on the recorder and you can enjoy them on the TV set and from the speakers.



Note

- The volume and tone (bass and treble) settings have no effect on the recording signals.
- When recording the analog signals from CD, AUX, F.AUX etc., be sure to select the analog input.

Customizing Settings

Setting the System

You can program additional sound settings.

- 1 Press **SETUP**.

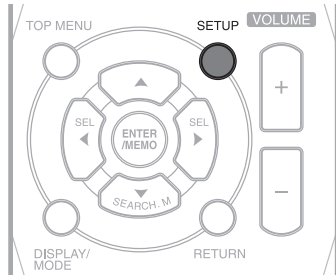

- 2 Press **▲** or **▼** to select a main menu.

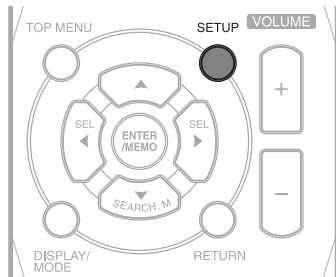

- 3 Press **ENTER/MEMO** to confirm.

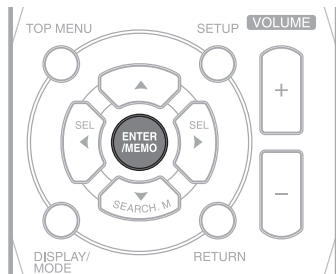

- 4 Press **▲** or **▼** to select an option.

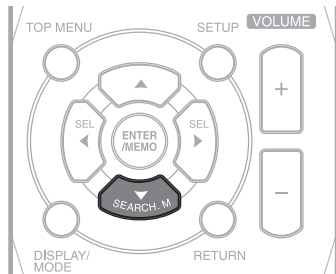

- 5 Press **ENTER/MEMO** to confirm the selected setting.

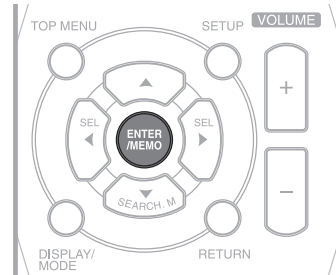

- 6 Press **▲** or **▼** to set a value.

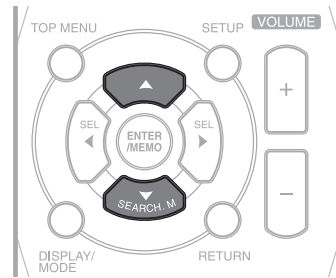

- 7 Press **ENTER/MEMO** to confirm.

- To return to the previous menu, press **RETURN**.
- To exit the menu, press **SETUP** again.

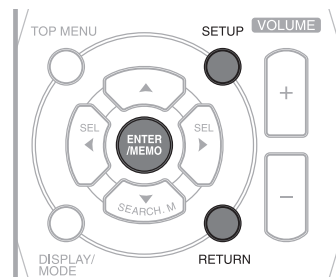

Setting Options Overview

Main Menu	Sub Menu	Go to Page	Description
1. SYS SET	AMP	44	Assigns the power amplifier.
	A.P.C.	44	Automatic Power Control.
	N.S.C.	44	Sets the standby time for the network.
2. SPK SET	A. SETUP	44	Automatically optimizes the speaker settings.
	SPK SET	46	Sets the speaker system.
	X.OVER	46	Sets the crossover frequency.
	DISTANCE	46	Sets the speaker distance.
	CH.LEVEL	46	Sets the current channel levels.
3. HDMI SET	HDMI	47	Sets the connected HDMI input source.
	CEC	47	Allows input selection of the main unit to be interlocked with the operation of the connected components.
4. PARAMTR	H.GAIN	47	Sets the front height channel level.
	PNRM	47	Sets to broaden the width of the front stereo image when using the Dolby Pro Logic IIx Music listening mode.
	C.WIDTH	47	Sets the center image so it may be heard only from the center speaker.
	DIEMN	47	Sets the sound field either towards the front or towards the rear.
	C.IMG	47	Sets the center image.
	DRC	48	Controls the dynamic range for movie soundtracks optimized for Dolby Digital, DTS, Dolby Digital Plus and Dolby TrueHD.
	TONE	48	Sets the tone (bass and treble) as desired.
	S.DLY	48	Adjust the time delay of audio signals to synchronize the sound with the picture.
	LFE	48	Sets the front height channel level.
5. MLT. RM	Z2	49	Sets to enable or disable the Room2 function.

Setting the System Setup

AMP Assign

The surround back channels' power amplifier can drive surround back speakers, front height speakers, and the ROOM 2 speakers. Depending on the purpose of the speakers, you should assign the power amplifier accordingly. For details, see "Connecting Speakers" on page 13 and "Connecting Multi-Room" on page 23.

Menu item	Description
Surround Back	Drives the surround back speakers when connecting the SURROUND BACK channels to them.
Front Height	Drives the front height speakers for Dolby Pro Logic IIz playback.
Room2	Drives the ROOM 2 speakers for ROOM 2 playback.

Automatic Power Control

You can set the standby time for the system to be turned off. The default setting value is 4H.

Network Standby Control

You can set whether the main unit can be turned on from other network devices.

Menu item	Description
ON	Enables the network standby function.
OFF	Disables the network standby function.

Setting the Speaker Setup

After you have installed this receiver and connected all the components, you should adjust the speaker settings for the optimum sound acoustics according to your environment and speaker layout. Whenever you change speakers, speaker positions, or the layout of your listening environment, you should also adjust the speaker settings, too.

Auto Setup

Auto Setup lets you avoid the more difficult listening-based speaker setup and achieve good surround sound automatically. Auto Setup provides the optimum listening environment for the listening position in your room. When performing the Auto Setup procedure, you do not need to perform the Speaker Configuration, Speaker Crossover, Speaker Distance and Channel Level setup procedures.

- 1 Check that the speakers are firmly connected to this receiver.
 - If your subwoofer has a volume control and crossover frequency, set the volume halfway and set the crossover frequency to the maximum or the low pass filter off.
- 2 Connect the supplied microphone to the SETUP MIC jack on the front panel.

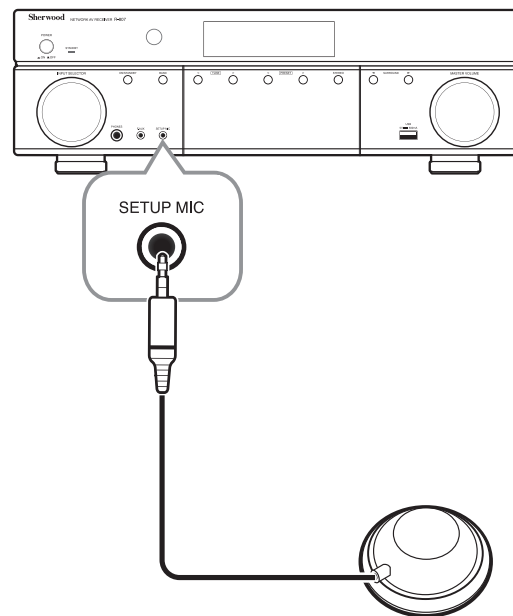

! Caution

- Since the microphone for Auto Setup is designed exclusively for this receiver, do not use a microphone other than the one supplied with this receiver.

3 Place the microphone on a flat level surface at the listening position.

- If possible, use a tripod or to fix the microphone at the same height as your ears would be when you are seated in your listening position.
- Ensure there are no obstacles between the speakers and the microphone.

4 Press ▲ or ▼ to select the Auto Setup, and then press ► button.

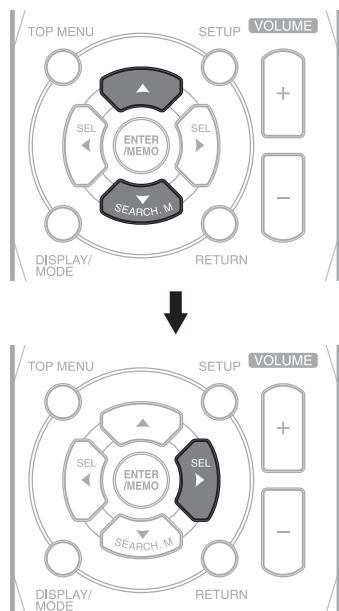

5 Press ► to start the auto setup procedure.

- Loud test tones are output played successively and when the auto setup procedure has been completed, "COMPLETED" will be displayed.
- To stop the auto setup procedure while performing it, press ◀.
- If there is a problem with speaker or microphone connection, an error message will be displayed. In this case, turn off the power, check the connection and then retry the auto setup procedure.

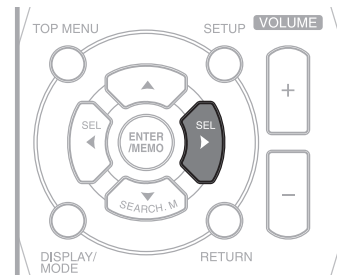

6 Press ► to memorize the results.

- The results are memorized and the Speaker Setup menu is displayed.
- When ◀ is pressed to select "CANCEL", the results are not memorized.
- Check the results on each setup menu ("Speaker Config", "Speaker Crossover", "Speaker Distance" and "Channel Level" menu on page 46).

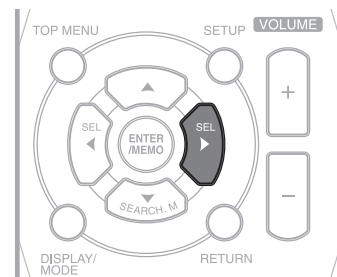

7 Disconnect the microphone after you have completed the auto setup procedure.

! Caution

- Because the test tones are loud, ensure there are no infants or young children in the room.



Note

- For best results, ensure the room is as quiet as possible during the auto setup procedure. If there is too much ambient noise, the results may not be satisfactory.
- If the results are not satisfactory, you can retry the auto setup procedure or personalize your speaker setup and channel level setup by choosing the settings manually. For details, see "Speaker Config", "Speaker Crossover", "Speaker Distance" and "Channel Level" procedure on page 46.

Speaker Setup

There are several ways you can use the speaker channels with the main unit. In addition to a normal home theater setup where they are used for the front height speakers, they can be used as an independent speaker system in another room.

- Select the desired speaker, and then press ► to enter its setting menu.

Menu item	Description
Yes/No	Selects the desired item depending on whether the speakers are connected or not.
2 Channel/ 1 Channel (Left)	Selects the desired item depending on the number of speakers connected to Surround Back/Multi channels.



Note

- When a speaker is not set to "NO", you need to set their distances from listening position and crossover frequencies according to their frequency characteristics. For details, see "Speaker Crossover" on page 46 and "Speaker Distance" on page 46.
- When the "SR" is set to "NO", "SB" cannot be set to "2 Channel" or "1 Channel (Left)".
- When the surround back channels' power amplifier is assigned to "Room 2", the "SB" cannot be selected. For details, see "AMP Assign" on page 44.

Speaker Crossover

You can set the crossover frequency according to the frequency characteristics of the connected speakers. For details on the frequency characteristics, refer to the operating instructions of the speakers.

- You can select the crossover frequency among Full Range, 40 Hz, 60 Hz, 80 Hz, 100 Hz, 120 Hz, 150 Hz, 200 Hz, and 250 Hz. The default setting is 100 Hz.
- Select "Full Range" when the selected speaker can fully reproduce frequencies below 40 Hz.



Note

- You cannot select the subwoofer and the speaker set to "NO".
- If the frequency range of your speaker is 100 Hz~20 kHz, the crossover frequency should be set to 100 Hz or slightly higher. For details, refer to the operating instructions of the speakers to be connected.
- Frequencies below the crossover frequency are output from the subwoofer or the speakers when they are set to "Full Range" (when not using a subwoofer).

Speaker Distance

- Select the desired unit (Meter or Feet) before setting the speaker distance. Once a unit is selected, the distances are automatically converted to the selected unit.
- You can set the distance within the range of 0.1 ~ 9.0 meters in 0.1 meter intervals (or 0.5 ~ 30.0 feet in 0.5 foot intervals).

About the speaker distance

When enjoying multi-channel surround playback with sources such as Dolby Digital and DTS sources, etc., it is ideal that the center, surround, and surround back speakers should be the same distance from the main listening position as the front speakers. By entering the distance between the listening position and each speaker, the delay times of center, surround and surround back speakers, etc. are automatically adjusted to create an ideal listening environment virtually as if they were in their ideal locations.

Speaker Channel Level

You can adjust the current channel levels as desired. After adjusting each channel level with the test tone, adjust the channel levels either according to the program sources or to suit your tastes. For details, see "Adjusting each channel level with test tone" on page 30.

Setting the HDMI Setup

HDMI

You can specify the routing of the HDMI audio signal from the system or through to a TV or flat screen TV. The HDMI connection can carry uncompressed digital video signals and digital audio signals. Depending on whether the digital audio signals input into the HDMI IN are output from the HDMI MONITOR OUT of the main unit or not, you should set the HDMI Audio Output correctly.

Menu item	Description
AMP	Disables HDMI digital audio signals output from the HDMI MONITOR OUT of this main unit. Then, these signals are heard from the speakers connected to this receiver.
TV	Enables HDMI digital audio signals output from the HDMI MONITOR OUT of the main unit. Then, these signals are heard from the speakers of your TV.



Note

- If the HDMI Audio Output is set to "TV", no sound will be heard from the speakers connected to this receiver (except ROOM 2 speakers) even if an input source is selected.

CEC Control

The CEC Control function allows input selection of the main unit to be interlocked with the operation of the connected components.

Menu item	Description
On	Enables the CEC Control function.
Off	Disables the CEC Control function.

Setting the Surround Parameter Setup

Height Gain

You can adjust the front height channel level as desired (This setting is valid only when listening in Dolby Pro Logic IIz mode).

Menu item	Description
L : Low	Decreases the front height channel level.
M : Mid	Outputs the front height channel sound with standard sound volume level.
H : High	Increases the front height channel level.

PANORAMA

You can extend the front stereo image to include the surround speakers for an exciting effect with side wall imaging.

Menu item	Description
On	Enables the panorama effect.
Off	Disables the panorama effect.

Center Width

This adjusts the center image so it may be heard only from the center speaker, only from the left or right speakers as a phantom image, or from all three front speakers to varying degrees. The control can be set in 8 steps from 0 to 7.

Dimension

This function gradually adjusts the sound field either towards the front or towards the rear. The control can be set in 7 steps from -3 to +3.

Center Image

When one of the Neo:6 is enabled, you can adjust the level of the center image so it may be heard from the center speaker more. The level can be adjusted in 11 steps from 1 to 10.

DRC

This function compresses the dynamic range of previously specified parts of the Dolby Digital, Dolby TrueHD or DTS sound track (with extremely high volume) to minimize the difference in volume between the specified and non-specified parts. This makes it easier to hear the full sound track when watching movies at night at low levels.

Menu item	Description
Auto	Adjusts the dynamic range compression automatically (Dolby TrueHD only).
Off	Turns off the DRC function.
Mid	Sets to Mid compression.
Max	Sets to Max compression.

Tone

You can adjust the tone (bass and treble) as desired.

Menu item	Description
On	Adjusts the tone for your taste.
Off	Listens to a program source without the tone effect.

Adjusting the tone (Bass and Treble)

You can adjust the tone if the Tone is set to "ON".

- 1 Select the desired tone by pressing ▲ or ▼, and then press ►.

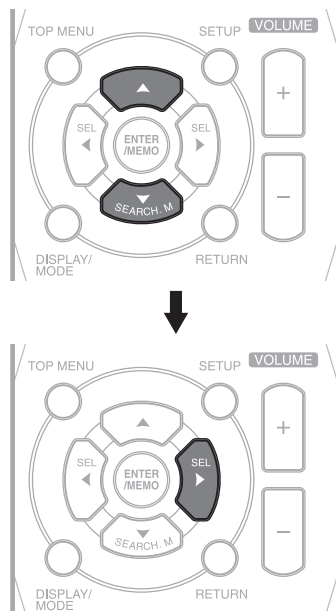

- 2 Adjust the selected tone as desired by pressing ▲ or ▼.

- The tone level can be adjusted within the range of -10 ~ +10 dB.
- It is recommended the bass and treble to be adjusted to 0 dB (flat level).

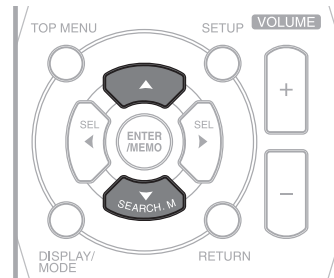

! Caution

- Extreme settings at high volume may damage your speakers.

Sound Delay

Some monitors have a slight delay during video playback, so the soundtrack will be slightly out of sync with the picture. By slightly increasing delay, you can sync the sound to the video. The delay can be adjusted within the range of 0 ms ~ 90 ms.

Low Frequency Effect

This channel reproduces low-frequency bass signals and has a frequency range from 20 Hz to 120 Hz. This channel is added to the channels for all bands with Dolby Digital or DTS to enhance low frequency audio effects. When the receiver is connected to a subwoofer, you can produce LFE (low-frequency effect) channel sounds and reinforce the bass parts of other channels.

The Low Frequency Effect can be disabled and set in 4 steps from -20 dB to 0 dB.

Setting the Multi Room Setup

In addition to your main room, you can also enjoy playback in Room2.

Menu item	Description
On	Turns on the Room2 function.
Off	Turns off the Room2 function.



Note

- When Room2 is set to "OFF", the input and the volume cannot be selected.
- When you do not use the Room2 function, set the Room2 to "OFF" to save electricity.
- The digital signals (including signals from the USB IN) cannot be output to the other rooms, meaning no playback in Room 2.

Setting the Network Setup

To listen to Internet radio stations or music files stored on your computer via a wired/wireless network, you should configure network settings first.

- 1 Press **SETUP** on the remote control.
- 2 Press **▲** or **▼** to navigate up or down the menu.

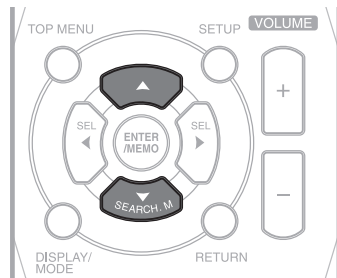

- 3 Press **ENTER** to confirm the desired menu. Press **RETURN** to move to the previous menu.

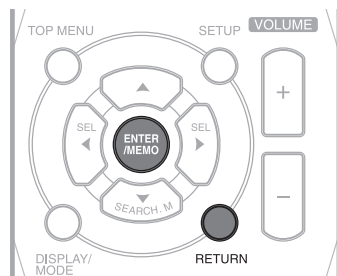

Network Settings Overview

Main Menu	Sub Menu	Go to Page	
NETWORK CONNECT	Direct AV Set	Soft AP hotspot	49
		Wi-Fi direct	49
	Wired	Ethernet	50
		Ethernet Configuration	50
OTHER	AP Name		50
	Resolution		50
	Display size		50
	Factory Setting		50
INFORMATION	Network Information		50
	Passcode Information		50

Setting the Direct Wireless Network Connection

You can connect the main unit with a mobile device wirelessly through Soft AP hotspot or Wi-Fi direct.

Soft AP hotspot

When you enable Soft AP hotspot, you can use the main unit as a wireless access point. It provides internet access to network devices.

Wi-Fi direct

Wi-Fi Direct is a standard that allows Wi-Fi devices to connect to the main unit without the need for a wireless access point. When you enable Wi-Fi Direct, you can directly transfer data between Wi-Fi direct devices and the main unit without the need for full setup.

Setting the Wired Network Connection

Before you setup the connection, check that the LAN cable is connected to the LAN/ETHERNET connector properly and securely. For details, see “Connecting to LAN cable” on page 20.

Ethernet

You can enable and set the Ethernet connection automatically on the main unit.

Ethernet Configuration

You can set the Ethernet connection settings manually.

Menu item	Description
Ethernet Device	Inputs an Ethernet device name.
Connection Type	Sets the connection type as DHCP or Static IP.
IP Address	Inputs IP Address.
Netmask	Inputs subnet mask when the DHCP function is disabled.
DNS address	Inputs DNS address when the DHCP function is disabled.
Default Router	Inputs Default Router when the DHCP function is disabled.



Note

- When you set DHCP as a connection type, you do not need to set the IP Address, Netmask, or DNS address etc.
- When you set Static IP as a connection type, you should set the network connection manually by entering the IP Address, etc. In this case, some knowledge of networks is required. If you do not understand internet connections, contact your internet service provider.

Setting Other Network Options

Menu item	Description
AP Name	Views and changes the name of the unit displayed on the network.
Resolution	Sets the resolution of the video output.
Display size	Adjusts the screen display size manually.
Factory Setting	Resets all the settings to the factory default.

Viewing the Network Information

Network Information

You can view the detailed information of a connected network.

Passcode Information

You can view and change the passcode of the main unit. When you use the main unit for the first time, you should input this passcode when you enable Soft AP hotspot and try to connect the mobile device to the main unit.

Troubleshooting

If you experience any of the following difficulties while using the system, use this troubleshooting guide to help remedy the problem before requesting servicing. Should any problem persist, consult your nearest authorized dealer or authorized independent company.

If the unit does not operate normally due to external influence such as static electricity, disconnect the power plug from the outlet and insert again to return to normal operating conditions.

GENERAL

Problem	Remedy
The power does not turn on.	<ul style="list-style-type: none"> • Disconnect the power plug from the outlet, and connect again.
The system suddenly turns off.	<ul style="list-style-type: none"> • After about a minute (you won't be able to turn the main unit on during this time), turn the system back on. If the message persists, call an authorized independent service company.
No sound is heard after a function is selected.	<ul style="list-style-type: none"> • Make sure the component is connected correctly. (See "CONNECTIONS" on page 10.) • Press MUTE to restore the sound.
Can't operate the remote control.	<ul style="list-style-type: none"> • Replace the batteries. (See page 6.) • Operate within 7 m, and 30° of the remote sensor. • Remove any obstacles, or operate from another position. • Avoid exposing the remote sensor on the front panel to direct light.
The display is dark or off.	<ul style="list-style-type: none"> • Press DIMMER on the control repeatedly to return to the default setting.

SOUND

Problem	Remedy
There is no sound from the selected component.	<ul style="list-style-type: none"> • Check that the component is connected correctly to the audio input jacks of components. • Ensure that the cords are fully inserted into the jacks on both the component and the main unit. • Ensure that the component is selected correctly. • Ensure that the equipment is connected correctly to the HDMI jack for that equipment. • Depending on the playback equipment, you may need to adjust the HDMI setting of the equipment. Refer to the operating instructions supplied with the equipment. • Be sure to use a High Speed HDMI cable when you view images or listen to sound, especially for the 1080p, Deep Color (Deep Colour) or 3D transmission. • Audio signals (format, sampling frequency, bit length, etc.) transmitted from an HDMI jack may be suppressed by the connected equipment. Check the setup of the connected equipment if the image is poor or the sound does not come out of the equipment connected via the HDMI cable. • When the connected equipment is not compatible with copyright protection technology (HDCP), the image and/or the sound from the HDMI TV OUT jack may be distorted or may not be output. If this is the case, check the specification of the connected equipment.

R-807 NETWORK AV RECEIVER

Problem	Remedy
Sound is interrupted or there is noise.	<ul style="list-style-type: none"> • Check the output audio formats support system. • Check that the speakers and equipment are connected securely. • Move your audio equipment away from the TV. • The plugs and jacks are dirty. Wipe them with a cloth slightly moistened with alcohol.
No sound is heard or there is noise when software with DTS is played back.	<ul style="list-style-type: none"> • Set the digital volume level of the system to full, or to the neutral position. • Ensure the main unit's settings are correct and/or the DTS signal out is on. Refer to the instruction manual supplied with the DVD player.
The left and right sounds are unbalanced or reversed.	<ul style="list-style-type: none"> • Ensure that the speakers and equipment are connected correctly and securely. • Adjust the sound level parameters using the Speaker Settings menu.
Recording cannot be carried out.	<ul style="list-style-type: none"> • Ensure that the equipment is connected correctly. • Select the source equipment using the input buttons (See page 26). • Audio input signals via HDMI IN and DIGITAL IN jacks cannot be recorded. • Copyright protection to prevent recording is contained in the sources. In this case, you may not be able to record from the sources.
A test tone is not produced from the speakers.	<ul style="list-style-type: none"> • The speaker cords may not be connected securely. Check to see if they are connected securely and cannot be disconnected by pulling on them slightly. • The speaker cords may have a short-circuit problem.
A test tone is heard from a different speaker than the speaker displayed on the TV screen.	<ul style="list-style-type: none"> • The speaker pattern set up is incorrect. Make sure that the speaker connections and the speaker pattern match correctly.
No sound, or sound suddenly ceases.	<ul style="list-style-type: none"> • If you've made separate connections for audio, make sure you have assigned the analog/digital jack(s) to the corresponding HDMI input for the component. • Check the audio output settings of the source component. • If the component is a DVI device, use a separate connection for the audio.

VIDEO

Symptom	Remedy
No image appears on the TV.	<ul style="list-style-type: none"> • Select the appropriate input using the input buttons. • Set your TV to the appropriate input mode. • Move your audio equipment away from the TV. • Assign the component video input correctly. • Make sure that cables are correctly and securely connected to equipment.
Recording cannot be carried out.	<ul style="list-style-type: none"> • Check that the equipment is connected correctly. • Select the source equipment using the input buttons (See page 26). • Video input signals via HDMI IN and COMPONENT VIDEO IN jacks cannot be recorded. • Copyright protection to prevent recording is contained in the sources. In this case, you may not be able to record from the sources.
No picture or sound.	<ul style="list-style-type: none"> • If the problem still persists when connecting your HDMI component directly to your monitor, consult the component or monitor manual or contact the manufacturer for support.

Symptom	Remedy
No picture.	<ul style="list-style-type: none"> Depending on the output settings of the source component, the video format may not be displayed. Change the output settings of the source, or connect your source component directly to TV using the component or composite video jacks. This system is HDCP-compatible. Check that the components you are connecting are also HDCP-compatible. If they are not, please connect your source component directly to TV using the component or composite video jacks. Some source components will not work with the main unit (even if it is HDCP-compatible). In this case, connect your source component directly to TV using the component or composite video jacks. If video images do not appear on your TV or flat screen TV, try adjusting the resolution, DeepColor or other setting for your component. To output signals in DeepColor, use an HDMI cable (High Speed HDMI Cable) to connect the main unit to a component or TV with the DeepColor feature.

USB DEVICE

Symptom	Remedy
There is noise, skipping, or distorted sound.	<ul style="list-style-type: none"> Turn off the receiver and reconnect the USB device, then turn on the main unit. The music data itself contains noise, or the sound is distorted.
The USB device is not recognized.	<ul style="list-style-type: none"> Turn off the main unit, then disconnect the USB device. Turn on the main unit again and reconnect the USB device. Connect the supported USB device (See page 31). The USB device does not work properly. Refer to the USB device operating instructions on how to deal with this problem.
Playback does not start.	<ul style="list-style-type: none"> Turn off the main unit and reconnect the USB device, then turn on the main unit. Connect the supported USB device (See page 31).
The USB device cannot be connected into the (USB) port.	<ul style="list-style-type: none"> The USB device is being inserted upside down. Connect the USB device in the correct orientation.

NETWORK CONNECTION

Symptom	Remedy
The main unit cannot connect to the WPS via a wireless LAN connection.	<ul style="list-style-type: none"> You cannot connect to a network using WPS when your access point is set to WEP. Set up your network after searching the access point using the access point scan.
The receiver cannot connect to the network.	<ul style="list-style-type: none"> Check the network status. When the system is connected through a wireless network, move the main unit and the wireless LAN router/access point closer to each other and do the setup again. Check the settings of the wireless LAN router/access point and do the setup again. For details on the settings of the devices, refer to the operating instructions of the devices. Make sure that you use a wireless LAN router/access point. Wireless networks are influenced by electromagnetic radiation emitted by microwave ovens and other devices. Move the main unit away from these devices
Cannot select the Network Settings menu.	<ul style="list-style-type: none"> Wait for a few moments after you have turned on the main unit, and then select the Network Settings menu again.

Important Information Regarding the HDMI Connection

Some HDMI signals cannot be routed through this system. (This depends on the HDMI-equipped component you are connecting. Check with the manufacturer for HDMI compatibility information.)

If you cannot receive HDMI signals properly through the main unit (from your component), please try the following configuration when connecting.

Additional Information

Specifications

Audio Section	
Multichannel power	75 W per channel, two channels driven @ 6 ohms, 20 Hz – 20 kHz, <0.1 % THD; 100 W per channel, two channels driven @ 6 ohms, 1 kHz, <1 % THD
Input sensitivity/impedance	200 mV/47k ohms
Signal-to-noise ratio (IHF-A)	95 dB
Surround system adjacent-channel separation	Dolby Pro Logic/PLII: 40 dB Dolby Digital: 55 dB DTS: 55 dB
Frequency response	10Hz – 100kHz: ± 3 dB
High instantaneous-current capability (HCC)	± 25 amps
FM Tuner Section	
Frequency range	87.5 – 108.0 MHz
Usable sensitivity IHF	1.3 μ V/13.2 dBf
Signal-to-noise ratio (mono/stereo)	65 dB/62 dB
Distortion (mono/stereo)	0.2 %/0.3 %
Stereo separation	35 dB @ 1 kHz
Image rejection	80 dB
IF rejection	80 dB
AM Tuner Section	
Frequency range	522 – 1161 kHz
Signal-to-noise ratio	45 dB
Usable sensitivity (loop)	500 μ V
Selectivity (± 10 kHz)	30 dB
IF rejection	80 dB

R-807 NETWORK AV RECEIVER

Video Section	
Television format	NTSC/PAL
Input level/impedance	1 Vp-p/75 ohms
Output level/impedance	1 Vp-p/75 ohms
Video frequency response (composite video)	10 Hz – 8 MHz (–3 dB)
HDMI	With 3 D and Deep Color

General Specifications	
Power requirement	AC 230 V/50 Hz
Power consumption	<0.5 W (standby), 280 W maximum
Dimensions (W x H x D)	17.12" x 4.9" x 13" (435 mm x 125 mm x 331 mm)
Weight	22.9 lb (10.4 kg)

Trademarks and Licenses

This system incorporates a sophisticated Digital Signal Processor that allows you to create optimum sound quality and sound atmosphere in your personal Home Theater.

DTS-HD Master Audio



Manufactured under license under U.S. Patent Nos: 5,956,674; 5,974,380; 6,226,616; 6,487,535; 7,212,872; 7,333,929; 7,392,195; 7,272,567 & other U.S. and worldwide patents issued & pending. DTS-HD, the Symbol, & DTS-HD and the Symbol together are registered trademarks & DTS-HD Master Audio is a trademark of DTS, Inc. Product includes software.

© DTS, Inc. All Rights Reserved.

HDMI



HDMI, the HDMI Logo, and High-Definition Multimedia Interface are trademarks or registered trademarks of HDMI Licensing LLC in the United States and other countries.

Dolby TrueHD



Manufactured under license from Dolby Laboratories. Dolby and double-D symbol are trademarks of Dolby Laboratories.

R-807

NETWORK AV RECEIVER
RÉCEPTEUR RÉSEAU AV
RECEPTOR A/V CON CONEXIÓN DE RED
NETZWERK-AV-RECEIVER
СЕТЕВОЙ AV-РЕСИВЕР