

YOLINK

Water Leak Sensor 2

YS7904-UC

Installation & User Guide

Rev 1.0

Contents

In the Box	1
Introduction	2
Set Up	5
Installation	7
Using the YoLink App	14
About YoLink <i>Control</i>	23
Maintenance	27
Specifications	30
Troubleshooting	31
Warning	32
Customer Service & Warranty	34

In the Box

- A. Water Leak Sensor
- B. Sensor Cable
- C. Mounting Hook
- D. Quick Start Guide

A.

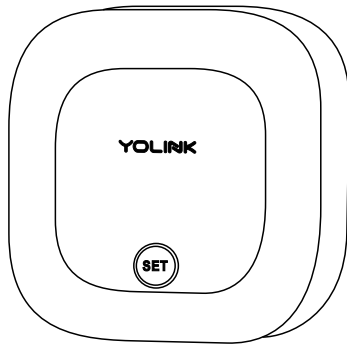

B.

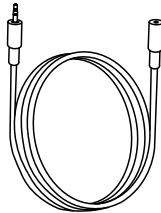

C.

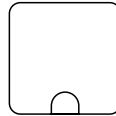

D.



Introduction

The YoLink Water Leak Sensor 2 is a smart water detector, that can detect the presence or absence of water, and can either

- In **water leak detection mode**, provide early warning of water leaks or flooding before costly property damage occurs
- In **water level detection mode**, provide notification of no water, for supervision of water supplies for pets, house plants, greenhouses, horticulture/agriculture, and so on

Cable Types: (see illustrations, next page)

Depending on your application for the sensor, a choice of cable is required. The **sensor cable** (included) can be used for both detection modes, but it is ideal for water leak detection mode. The **water sensor probe** (sold separately) is ideal for water level detection mode

The **sensor cable** detects water along the length of the cable, while the **water sensor probe** detects water only at the probe at the end of the cable

Operation & Notifications:

Depending on the water leak or level detection mode, the sensor LED will blink red and the sensor sounder will emit loud alarm tones. Notifications will be sent to you via the YoLink app (available notifications types are: email, text/SMS and push/banner notifications on your Apple or Android smartphone, each configurable in app settings)

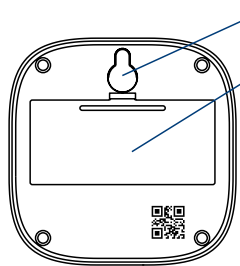

Wall-Mounting Slot

Battery Compartment

Includes two AAA non-rechargeable batteries

Phono Jack

Used for sensor cable extension

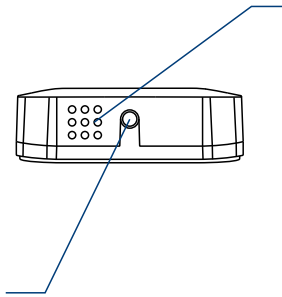

Alarm Tones

● **One Beep**

Device power-up / button pressed

● **Two Beeps**

Warning

(Two beeps every 2 seconds for the first minute. Two beeps every 5 seconds for the next 12 hours. Sustaining two beeps once a minute after 12 hours)

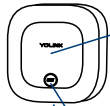

Status LED

** Not visible while there is no operation with the SET button or while device is in normal monitoring status*

SET Button

Phono Plug

Sensor Cable

Used for water detection

Phono Jack

Used for extending sensor cable

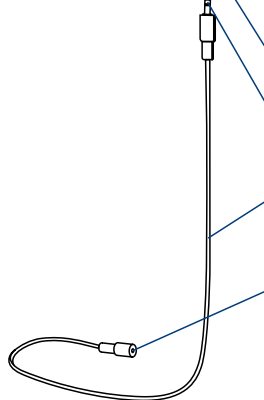

OR You can Replace the Sensor Cable with a Water Sensor Probe Instead
(Optional, Sold Separately)

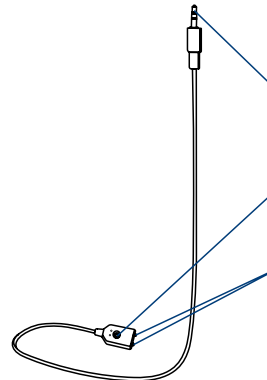

Phono Plug

Mounting Hole

Detector Probe

Used for water detection or low water level warning

The LED light indicates the current status of the sensor:

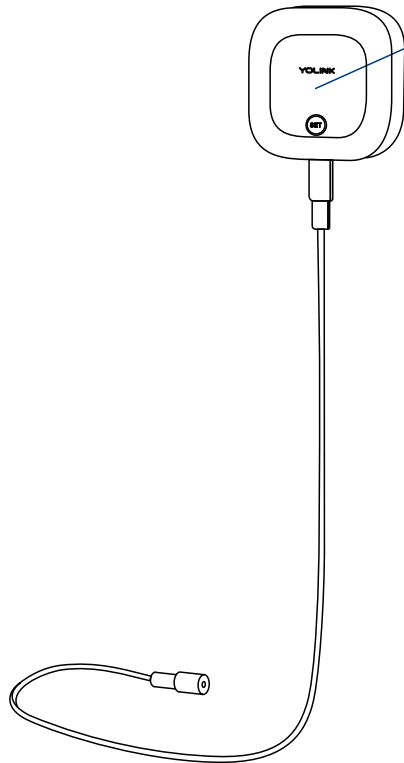

- **Blinking Red Once**
Leak or Flooding Warning (*water leak detection mode*)
Water Exhausted Warning (*water level detection mode*)
- **Blinking Green**
Connecting to Cloud
- **Fast Blinking Green**
Establishing Connection with YoLink System (*YoLink Control*)
- **Slow Blinking Green**
Updating
- **Fast Blinking Red**
Removing Connection to YoLink System (*YoLink Control*)
- **Blinking Red And Green Alternately**
Restoring to Factory Default

Set Up

Follow the steps below to set up your Water Leak Sensor 2 via the YoLink app

Set Up - First-Time YoLink Users *(Existing users proceed to **Add Device**, next page)*

*** Get ready:** To set up and use your Water Leak Sensor 2, you will need an Apple iPhone or tablet that is iOS 9.0 or higher, or an Android phone or tablet that is Android 4.4 or higher

- Download YoLink app through Apple App Store or Google Play Store
- Log in or create a new account if required
- YoLink Hub is required to set up your Water Leak Sensor 2. Please set up your YoLink Hub first (refer to YoLink Hub manual)

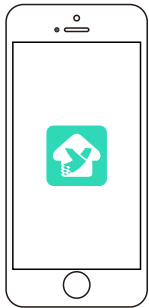

Download, and log in to YoLink app

1

** Make sure your hub is connected to the internet (green LED indicator is blinking, blue LED indicator is always on)*

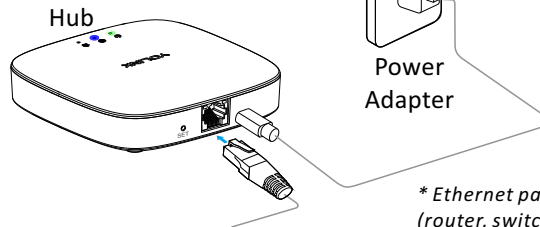

Set up YoLink Hub

2

** Ethernet patch cable (included) to your network (router, switch, etc.), recommended, but optional. Otherwise connect your Hub to your home Wi-Fi network. Refer to the Hub set up manual for more information:*



YS1603-UC_User Guide

Add Device

- Tap “” button, then scan QR Code on the device
- Press the SET button (on front of sensor) once, the Status LED will blink several times (red, then green). The green LED indicates the device is online and ready to use

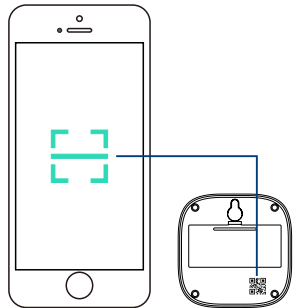

Tap “” button to add devices

①

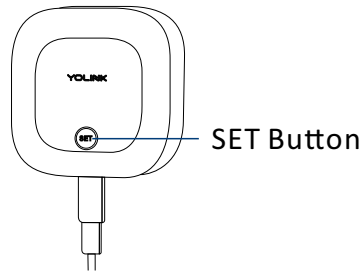

Press the SET button (on front of sensor) once

②

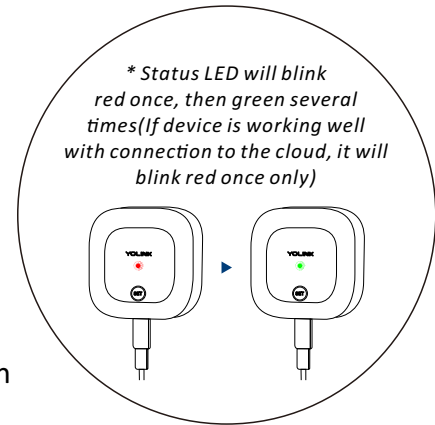

Installation

Test the Sensor Location Before Installation

- The mounting hook is very difficult to relocate after being affixed to the mounting surface. Test your sensor location before affixing the mounting hook to the surface. Use masking or painters tape to secure the mounting hook to the surface. Once you have the mounting hook temporarily mounted then hang the sensor on the hook, test out the sensor. With the app in hand, follow the **Device Alerts** section on page 17 to test water warning and warning removed using the app and observing the status of the sensor as shown on the app (Water Warning or Water Warning Removed). Optionally, you may set up your automation (e.g. turn off a valve when water is detected) to functionally test the alert of the sensor - proceed to the following steps for information on creating automations, then return to this step
- This sensor is not waterproof and is designed and intended only for indoor use. Subjecting this device to outdoor environment conditions such as direct sunlight, extreme hot or cold temperatures, rain, water and/or condensation can damage the device and will void the warranty
- If flooding is a risk mount the sensor at a higher location, where it is less likely to get wet (which may render it non-functional)
- Please refer to device environmental operation range on page 30. Use this device outside the recommended ranges at your own risk
- Avoid allowing the Water Leak Sensor 2 to be exposed to strong impacts or vibration
- Please add the Water Leak Sensor 2 to the YoLink app before installation

Select Your Sensor Location (Water Leak Detection Mode):

- Depending on your application for the sensor, determine the optimal location for the sensor cable (recommended) or water leak probe:
 - Place the cable directly under the potential source of a water leak (for example, under a dishwasher or water heater)
 - Place the cable on the floor at a location where flooding is possible (for example, next to a sump pump or sub-grade door in a basement)
 - If possible, locate the cable where it will not be disturbed by foot traffic or pets
 - As basement floors may be sloped to allow for drainage of water, for earliest warning select a location that is at a lower point rather than a higher point on the floor
- **Suggested Additional Applications:**
 - Basement Floors
 - Under Laundry Machines
 - Under Dishwashers
 - Under Refrigerators (w/Ice Machines)
 - Near Sump Pumps
 - Under Fish Tanks/Aquariums
 - Inside Hot Tubs*
 - Locations Subject to Freezing Pipes*

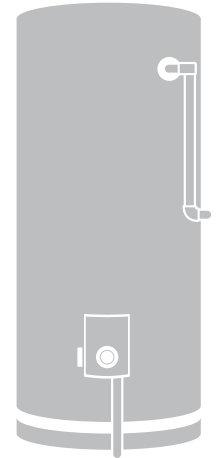

Select Your Sensor Location (Water Level Detection Mode):

- Depending on your application for the sensor, determine the optimal location for the water leak probe (recommended) or sensor cable:
 - Place the water leak probe cable with the probe in the water, positioned just below the acceptable water level (so that when the water level recedes, an alert will be sent)

Begin Installation

- Clean the installation area

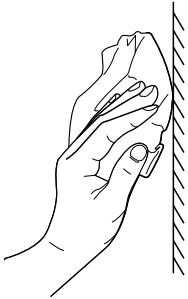

- Remove the protective layer on the double-sided tape on the bottom of the hook, Place the hook at the pre-determined location then press it firmly for at least 5 seconds

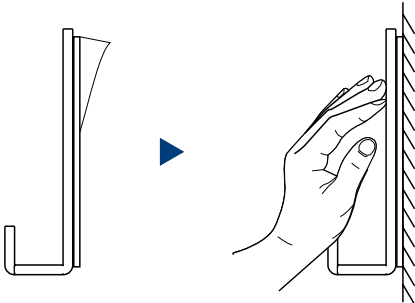

- ⚠ Skip to page 12 if you are using a water sensor probe instead of a sensor cable

Method A: Sensor Cable Installation

- Insert the sensor cable's phono plug into the water leak sensor's phono jack as shown

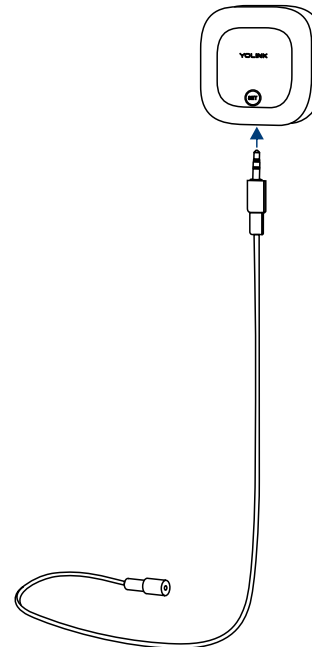

- Hang the sensor on the hook through the wall-mounting slot

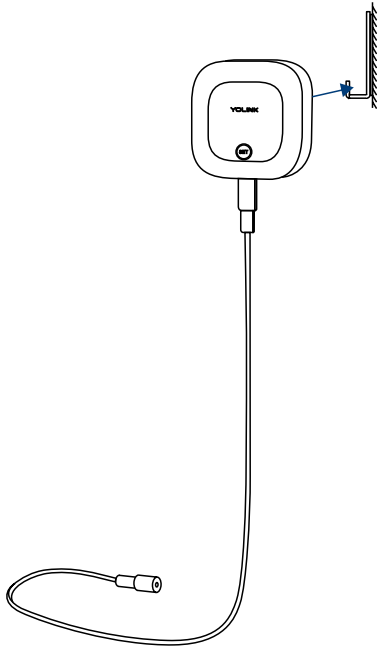

- Adjust the sensor cable, place it where a leak or flooding may occur, or where the water level will drop

** For water level monitoring, please do not bend the sensor cable in the detection area*

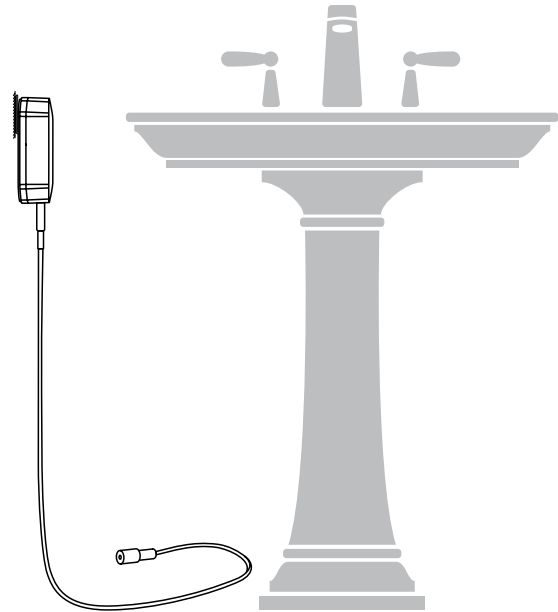

- **Sensor cable extension**

- Insert additional sensor cables as shown (red highlighted portions of the sensor cable are the detection areas), if needed (refer to page 30 for the extension cable specifications)

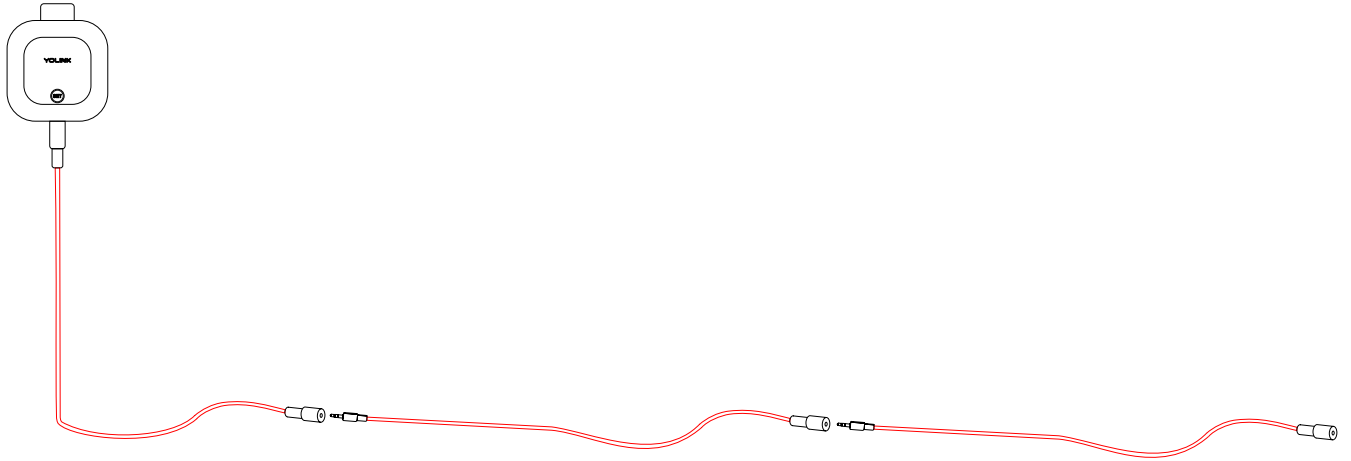

Method B: Water Sensor Probe Installation

- These Tools may be Required



Phillips Screwdriver



Hammer



OR



Nail

Self-tapping
Screw

OR



Double-sided
Mounting Tape

- Insert the water sensor probe's phono plug into the water leak sensor's phono jack as shown

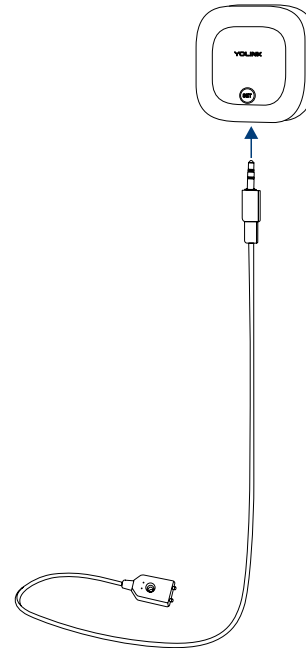

- Hang the sensor on the hook through the wall-mounting slot

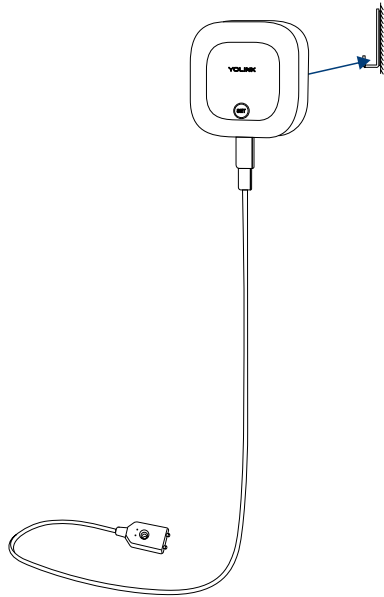

- Adjust the water sensor probe, placing it where a leak or flooding may occur, or where the water level will drop
- You can use a screw or nail or double-sided mounting tape to mount the detector probe

** Do not bend the water sensor probe in the detection area*

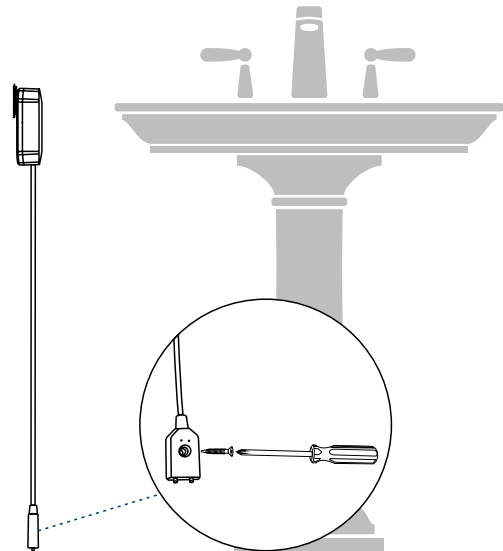

Using the YoLink App

Device page (Water Leak Detection Mode)

Device name
** Edit name on Details page*

Alert interval
** Set re-notification interval after a leak or flooding warning
Default is 5 minutes*

Details
** Tap to go to Details page (refer to page 16)*

Connection status
of sensor and Hub

Battery level
current battery level
** Shown red if replacement is required*

Real-time status:
Normal or water-detected

Device history
Water detected and cleared events, logged with date & time

Water Leak
Alert Interval
History

** Water detected*

Device page (Water Level Detection Mode)

Device name

** Edit name on Details page*

Alert interval

** Set re-notification interval after the water exhausted warning
Default is 5 minutes*



** Water exhausted*

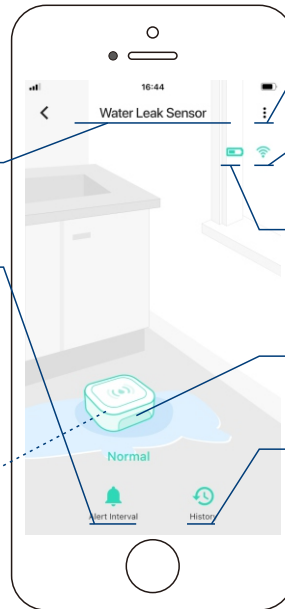

Details

** Tap to go to Details page
(refer to page 16)*

Connection status

of sensor and Hub

Battery level

current battery level

** Shown red if replacement is required*

Real-time status:

Normal or water-exhausted

Device history

Water detected and cleared events, logged with date & time

Details page

Device type

Rename the device

Choose a room for device

Add / remove from favorites

Device history

Water detected and cleared events, logged with date & time

Alert settings

* Enable or disable alerts

Alert interval

* Set re-notification interval after a leak or flooding warning or water exhausted warning
Default is 5 minutes

Beep sound

after a leak or flooding warning or water exhausted warning

Device mode settings

* Water Leak Monitor:
water leak detection mode.
Water Exhausted Monitor:
water level detection mode

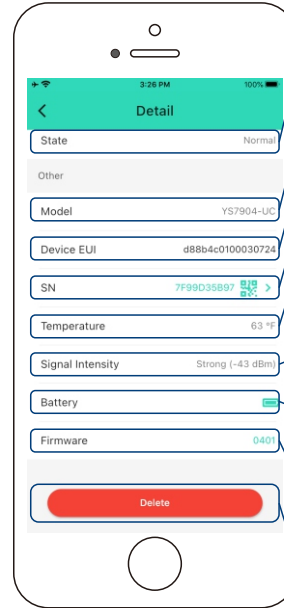
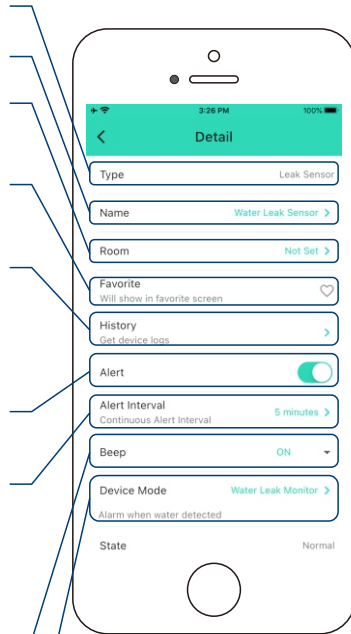

Device status

* Normal, Warning

Device model

Device EUI (unique)

Device SN (unique)

Temperature value

* Updates when:

1. SET button pressed
2. On a device alert
3. Batteries are replaced
4. Automatically within 4 hours maximum

Connection status

of sensor and Hub

Battery level

current battery level

* Shown red if replacement is required

Firmware version

* "#### ready now" indicates a new update is available (refer to page 27)

* Tap to delete the device from your YoLink account

* After changing "Alert Interval" and / or "Device Mode" and / or "Beep" settings, press the device's SET button once, to sync the new settings to the device. Otherwise, the device will automatically update within 4 hours (maximum)

Device Alerts

Water Leak Detection Mode

Method A: Sensor Cable

- When any point of sensor cable detects water, an alert notification will be sent, and the sensor status will be shown on your YoLink app (see page 2 for more information about notifications)

Note

- The default re-notification interval after a leak or flooding alert is 5 minutes. This interval may be adjusted in the Details page (refer to page 16)
- After a leak or flooding event, please remove the sensor cable from the sensor and do not reconnect it until both the sensor cable and location is dry

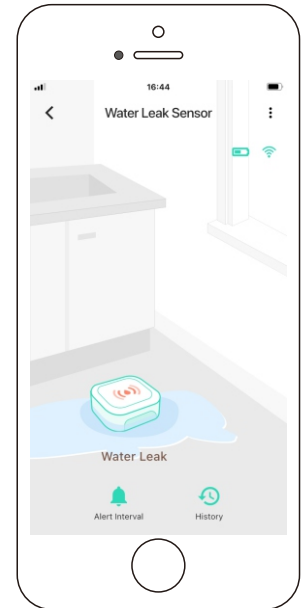

Method B: Water Leak Probe

- When both tips of the water leak probe are immersed in water, an alert notification will be sent, and the sensor status will be shown on your YoLink app (see page 2 for more information about notifications)

Note

- The default re-notification interval after a leak or flooding alert is 5 minutes. This interval may be adjusted in the Details page (refer to page 16)
- After a leak or flooding event, please remove the water sensor probe from the sensor and do not reconnect it until both the water sensor probe and location is dry

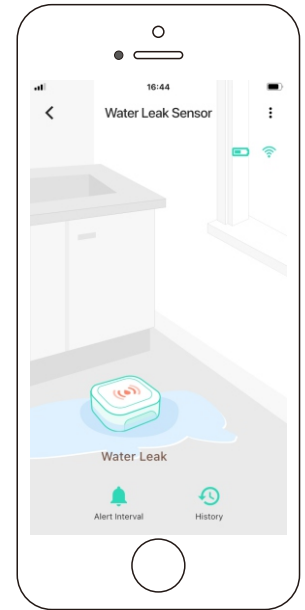
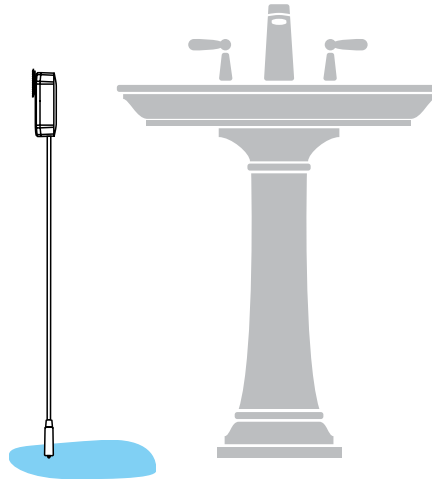

Water Level Detection Mode

Method A: Sensor Cable

- When no point on the sensor cable detects water, an alert notification will be sent, and the sensor status will be shown on your YoLink app (see page 2 for more information about notifications)

Note

- Only when no point on the sensor cable is wet will the device alert
- Sloshing of water may affect the status of sensor
- The default re-notification interval after a low water level alert is 5 minutes. This interval may be adjusted in the Details page (refer to page 16)

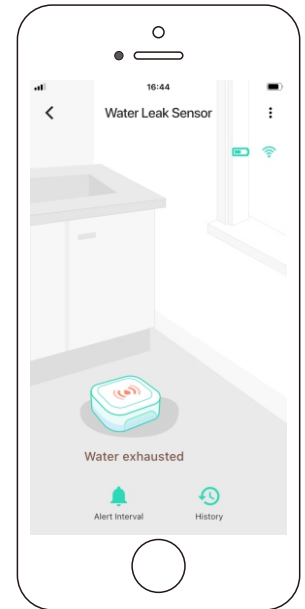
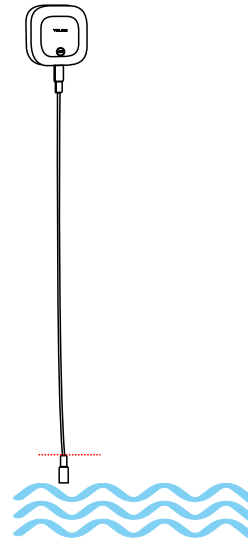

Method B: Water Sensor Probe

- When both tips of the water leak probe are touched without water, an alert notification will be sent, and the sensor status will be shown on your YoLink app (see page 2 for more information about notifications)

Note

- Only when both tips of the water leak probe are not wet, then the device will alert
- Sloshing of water may affect the status of sensor
- The default re-notification interval after a low water level alert is 5 minutes. This interval may be adjusted in the Details page (refer to page 16)

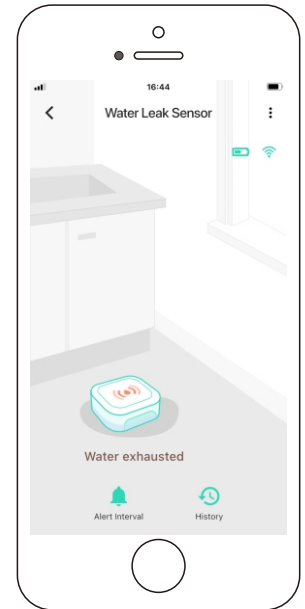
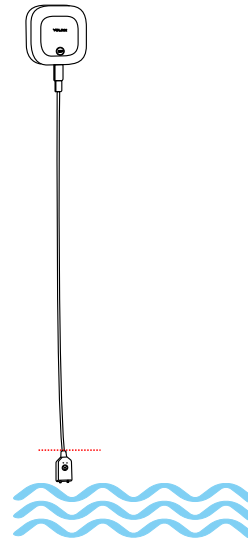

Automation

Easily set up rules for “if this then do that” functions

- Go to “Smart”, tap “Automation” followed by the “ + ” icon to add an automation
- Fill in details followed by the “ ✓ ” icon

** Water Leak Sensor 2 can be set as a trigger only*

Tap to add an automation

Tap “  ” button

to enable or disable the automation

** Click to edit the automation.*

Swipe left to view the history logs and to edit or delete the automation

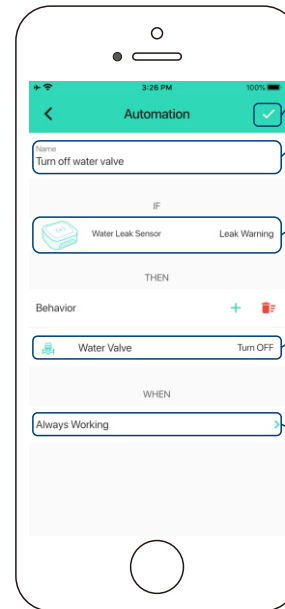
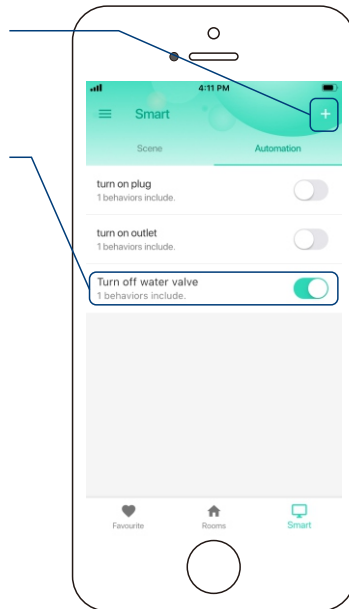
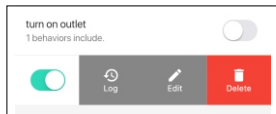

Tap to save the settings

Edit name
for the automation

Edit trigger

Edit behavior

** You must have at least one action device, or you cannot set a behavior*

Edit when

** Set a time range for the automation (always or during specific days / times)*

Voice Assistants

Connect YoLink with third-party voice assistants service to monitor the status of your devices through voice commands

- Tap “☰” in the upper left corner to go to My Profile
- Go to **Settings > Voice Assistants** for the applicable voice assistant integration guide

** Water Leak Sensor 2 is integrated with Alexa, and is also integrated with IFTTT.com, works as trigger event pipelines using IFTTT*

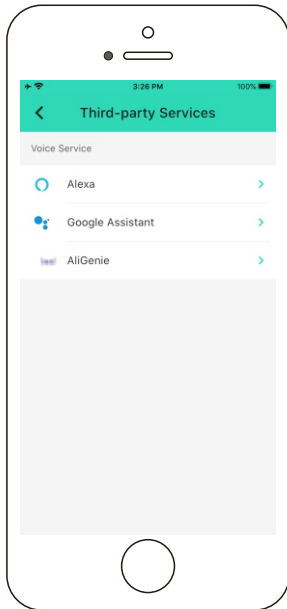

About YoLink *Control*

YoLink *Control* is our unique device-to-device control technology. Using YoLink *Control*, YoLink devices can be controlled without the Hub or an internet connection. (Use of YoLink *Control* is optional; you can use the Automation feature in the app OR use YoLink *Control*, but YoLink *Control* offers the benefit of operation without the Hub or internet connection.)

One device controls another, directly. A device that sends out commands is called the controller. A device that receives the commands is called the responder. Examples of a controller are a Water Leak Sensor, while examples of a responder are a Siren or a Gas/Water Valve (Controller)

The Water Leak Sensor 2 can only work as the controller in YoLink *Control*

Pairing

- To configure your Water Leak Sensor 2 as a controller, press and hold the SET button for 5-10 seconds until the LED quickly blinks green
- To configure a Gas/Water Valve Controller as the responder, ensure the Gas/Water Valve Controller (refer to Gas/Water Valve Controller manual) has already been bound to the YoLink app. Using the app, close the valve (verify the valve is shown to be Closed on the app, or press the Close button if it is shown as Open). Press and hold the SET button for 5-10 seconds until the LED quickly blinks green
- Upon pairing, the LED will stop blinking (this may happen after only blinking two or three times)

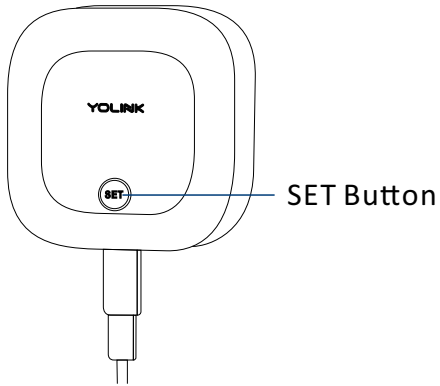

Hold the SET button for 5-10 seconds,
until the green light blinks quickly

1

Close the valve

** Verify the valve is shown to be **Closed**
on the YoLink app, or press the SET button
on the controller if it is shown as Open*

** Refer to the Gas/Water Valve Controller
manual for more information:*



YS4909-UC_Gas/Water
Valve Controller

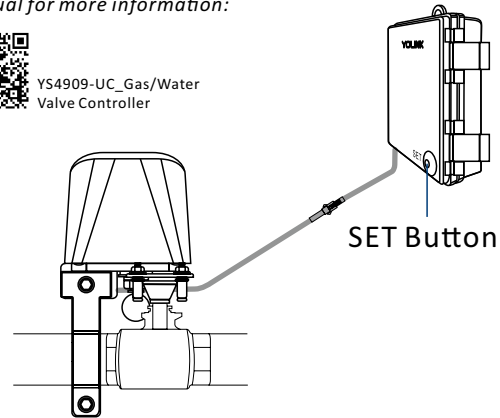

Hold the SET button on the Gas/Water
Valve Controller for 5-10 seconds, until
the green light blinks quickly

2

** If you want to open the gas/water valve when the
sensor alerts (either water detected warning or low water
level warning), open the gas/water valve first, and let the
controller enter pairing mode*

Operation

- Either the Water Leak Sensor 2 detects water or detects the absence of water (depending on the alert mode set in Details page in YoLink app), the YoLink Gas/Water Valve will now immediately close. The valve will remain closed until opened via the app; the restoration of the Water Leak Sensor to normal (no water detected) does not open the valve
- More advanced sequences, controlling multiple outputs (e.g. close valve and activate siren) are available via the YoLink app

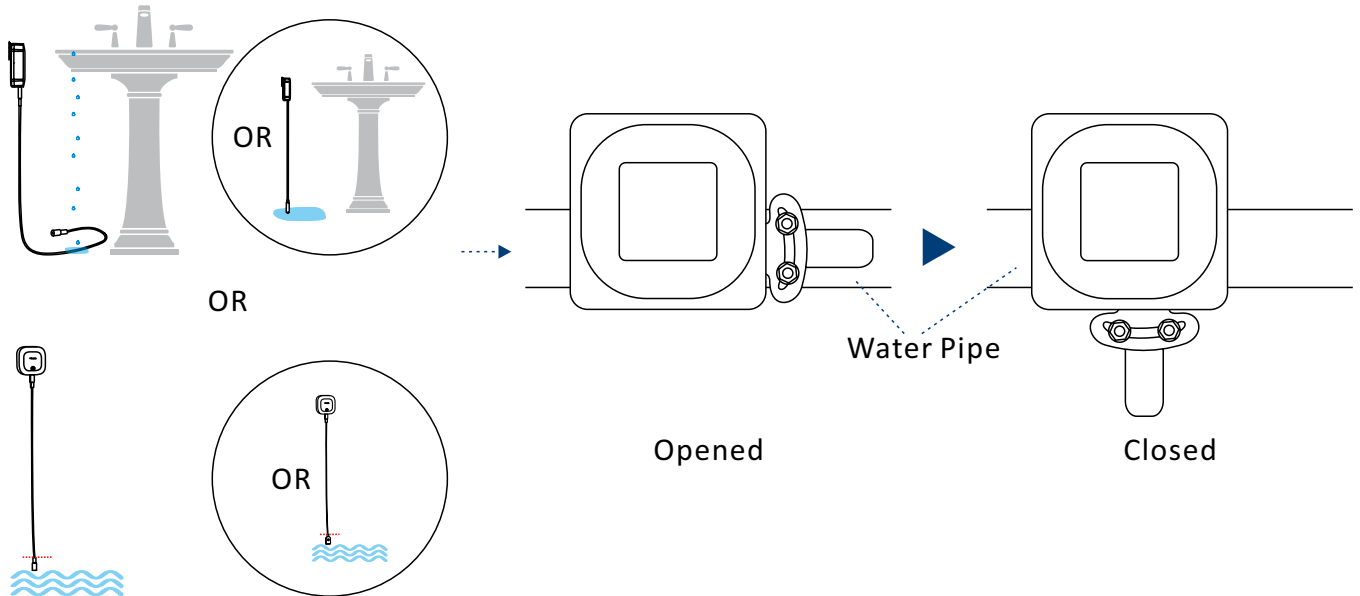

Unpairing

- At the Water Leak Sensor 2 (controller), press and hold the SET button for 10-15 seconds until the LED quickly blinks green, then red
- At the Gas/Water Valve Controller (responder), press and hold the SET button for 10-15 seconds, until the LED quickly blinks green, then red
- Upon un-pairing, either the Water Leak Sensor 2 LED or the Gas/Water Valve Controller LED will stop blinking and turn off
- The Gas/Water Valve Controller will no longer respond to the Water Leak Sensor 2

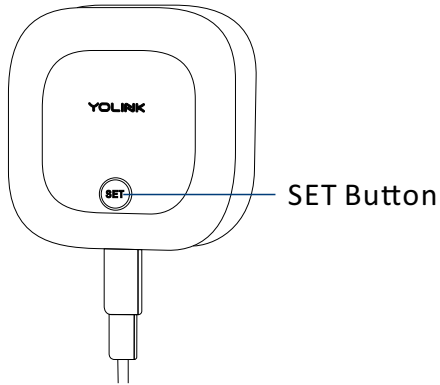

Hold the SET button for 10-15 seconds, until the red light blinks quickly

1

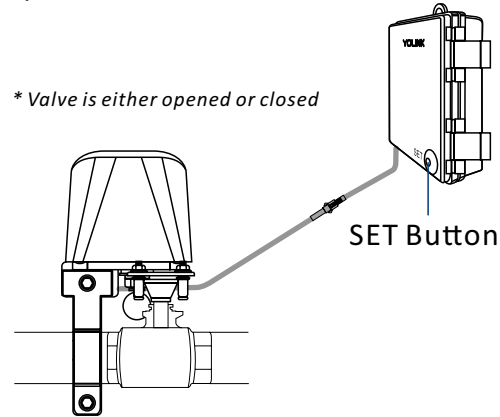

Hold the SET button on the Gas/Water Valve Controller for 10-15 seconds, until the red light blinks quickly

2

Maintenance

Firmware Update

To ensure our customers have the best user experience, we highly recommend you update to the newest version firmware when an update is available

- In “Firmware”, if a new version is listed as available (#### ready now), click it to start the firmware update process
- The device's firmware will be updated automatically within 4 hours (maximum). To force an immediate update, press the SET button on the device once to make the device enter update mode
- You may use your device during the update as it is performed in the background. The LED light will slowly blink green during the update and the process will be complete within 2 minutes after the light stops blinking

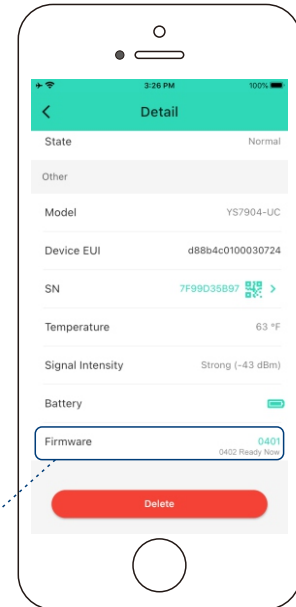

Firmware 0401
0402 Ready Now

Factory Reset

Factory reset will erase all of your settings and restore it to factory defaults. After the factory reset, your device will remain in your Yolink account

- Hold the SET button for 20-25 seconds until the status light blinks red and green alternately, then, release the button (*Hold the SET button longer than 25 seconds will ABORT the factory reset operation*)
- Factory reset will be complete when the status light stops blinking

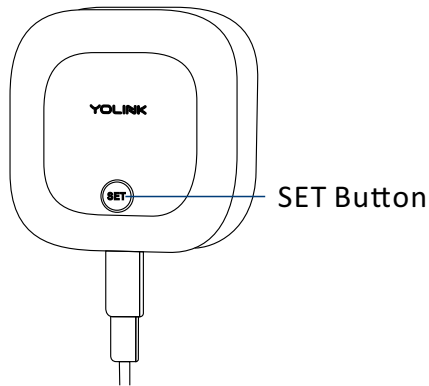

Replacing the Batteries

- Remove the sensor from its mounting location
- Optionally, remove the sensor cable
- Open the battery cover and remove the old batteries
- Observing polarity, insert two new AAA batteries and close the battery cover
- Please note: do not mix old and new batteries

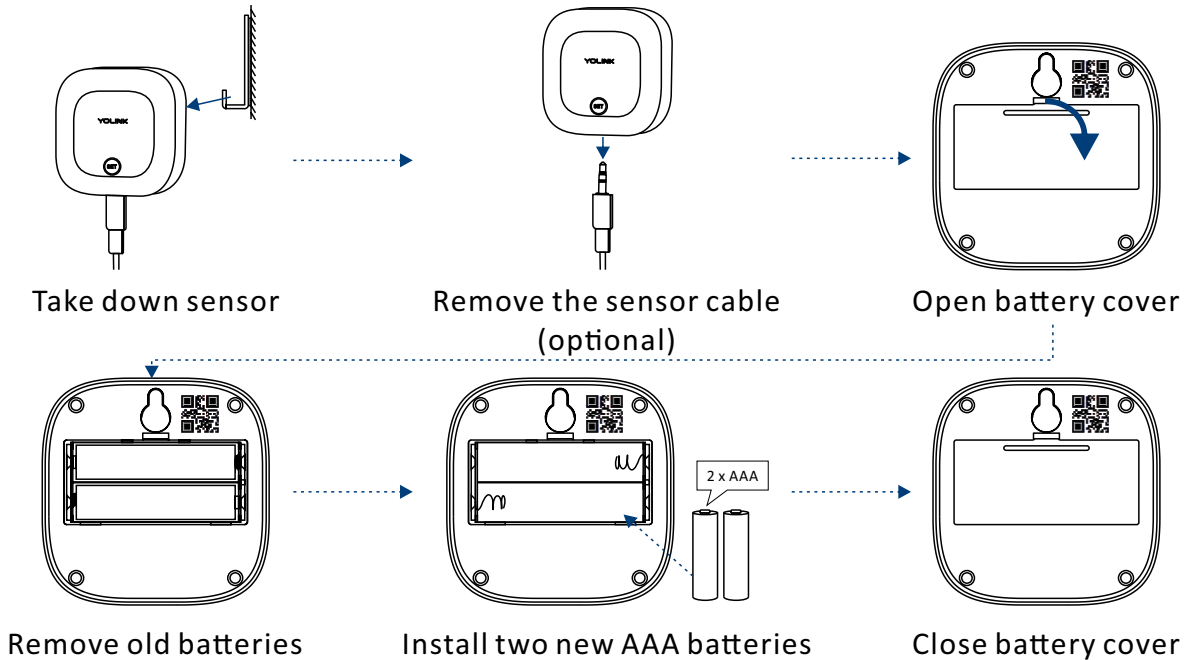

Specifications

Voltage: 3V DC (2 - Alkaline Non-Rechargeable AAA Batteries)

Dimensions: 2.44 x 2.44 x 0.80 inches (L x W x D)

Alert Sounder Volume: 95-105 dB (@10cm)

Sensor Cable: 4.2 feet (1.2 meters), can be extended up to at least 55 feet (16.8 meters)

Environment: Working Temperature: 32°F - 122°F (0°C - 50°C)
Working Humidity: ≤95%RH non-condensing

Troubleshooting

Hardware:

- 1. Batteries:** Batteries should be brand new, name brand “AAA” alkaline type. Refer to “Warnings” Section on page 32
- 2. Status LED blink red every 30 seconds:** the condition of the batteries is in question, replace the batteries with 2 premium “AAA” alkaline batteries

Symptoms:

1. Device is offline

- If sensor is not connected to the cloud, press the SET button on water leak sensor once
- If Hub is offline, reconnect the Hub to the Internet and press the SET button on water leak sensor once
- If Hub is not on, power on the Hub again and press the SET button on water leak sensor once
- If sensor is out of range with Hub, relocating the sensor or Hub may be required
- For a device with low-battery indicators or alerts or if the condition of the batteries is in question, replace the batteries with 2 premium “AAA” alkaline batteries

2. Other issues, contact customer service, **1-949-825-5958 (M-F 9am - 5pm PST)**

Warning

- Please install, operate and maintain the Water Leak Sensor 2 only as outlined in this manual. Improper use may damage the unit and/or void the warranty
- Use only new, name brand, alkaline non-rechargeable AAA batteries
- Do not use rechargeable batteries
- Do not use zinc blend batteries
- Do not mix new and old batteries
- Do not puncture or damage batteries. Leakage can cause harm on skin contact, and is toxic if ingested
- Do not dispose of batteries in fire as they may explode! Please follow local battery disposal procedures
- To avoid damaging the device, if storing the device for an extended period, remove the batteries
- Do not install or use this device outside of the temperature and humidity range listed in the Environmental section in Specifications, on page 30
- Do not install or use this device where it will be subjected to high temperatures and/or open flame
- This device is not waterproof and is designed and intended only for indoor use. Subjecting this device to outdoor environment conditions such as direct sunlight, extreme hot or cold temperatures, rain, water and/or condensation can damage the device and will void the warranty

- Install or use this device only in clean environments. Dusty or dirty environments may prevent the proper operation of this device, and will void the warranty
- If your Water Leak Sensor 2 does get dirty, please clean it by wiping it down with a clean, dry cloth. Do not use strong chemicals or detergents, which may discolor or damage the exterior and/or damage the electronics, voiding the warranty
- Do not install or use this device where it will be subjected to physical impacts and/or strong vibration. Physical damage is not covered by the warranty
- Please contact Customer Service before attempting to repair, disassemble or modify the device, any of which can void the warranty and permanently damage the device

If you have any difficulties installing or using your Water Leak Sensor 2, please contact our Customer Service department during business hours:

US Live Tech Support: **1-949-825-5958** M-F 9am - 5pm PST

Email: **service@yosmart.com**

YoSmart Inc. 17165 Von Karman Avenue, Suite 105, Irvine, CA 92614

Warranty 2 Year Limited Electrical Warranty

YoSmart warrants to the original residential user of this product that it will be free from defects in materials and workmanship, under normal use, for 2 years from the date of purchase. User must provide a copy of original purchase receipt. This warranty **does not cover** abuse or misused products or products used in commercial applications. This warranty does not apply to water leak sensor2s that have been improperly installed, modified, put to a use other than designed, or subjected to acts of God (such as floods, lightning, earthquakes, etc.). This warranty is limited to repair or replacement of the water leak sensor 2 only at YoSmart's sole discretion. YoSmart will NOT be liable for the cost of installing, removing, nor reinstalling this product, nor direct, indirect, or consequential damages to persons or property resulting from the use of this product. This warranty only covers the cost of replacement parts or replacement units, it does not cover shipping & handling fees

To implement this warranty please give us a call during business hours at 1-949-825-5958, or visit www.yolink.net

Copyright 2021. YoSmart, Inc. All rights reserved

FCC statement

This equipment has been tested and found to comply with the limits for a Class B digital device, pursuant to part 15 of the FCC Rules. These limits are designed to provide reasonable protection against harmful interference in a residential installation. This equipment generates, uses and can radiate radio frequency energy and, if not installed and used in accordance with the instructions, may cause harmful interference to radio communications. However, there is no guarantee that interference will not occur in a particular installation. If this equipment does cause harmful interference to radio or television reception, which can be determined by turning the equipment off and on, the user is encouraged to try to correct the interference by one or more of the following measures:

- Reorient or relocate the receiving antenna
- Increase the separation between the equipment and receiver
- Connect the equipment into an outlet on a circuit different from that to which the receiver is connected
- Consult the dealer or an experienced radio / TV technician for help

This device complies with part 15 of the FCC Rules. Operation is subject to the following two conditions:

- 1) This device may not cause harmful interference
- 2) This device must accept any interference received, including interference that may cause undesired operation. Any changes or modifications not expressly approved by the party responsible for compliance could void the user's authority to operate the equipment

Note: The manufacturer is not responsible for any radio or TV interference caused by unauthorized modifications to this equipment. Such modifications could void the user's authority to operate the equipment.

FCC RF radiation exposure statement

This equipment complies with FCC RF radiation exposure limits set forth for an uncontrolled environment. This device and its antenna must not be co-located or operating in conjunction with any other antenna or transmitter.

“To comply with FCC RF exposure compliance requirements, this grant is applicable to only Mobile Configurations. The antennas used for this transmitter must be installed to provide a separation distance of at least 20 cm from all persons and must not be co-located or operating in conjunction with any other antenna or transmitter.”