

PRO-FORM[®]

R 600

Model No. PFEVRW41016.0

Serial No. _____

Write the serial number in the space above for reference.

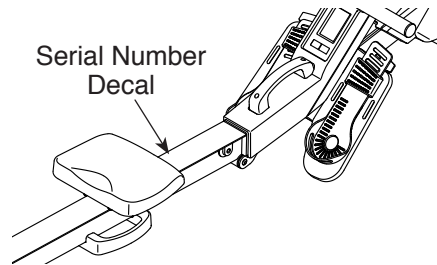

USER'S MANUAL

CUSTOMER SERVICE

UNITED KINGDOM

Call: 0330 123 1045

From Ireland: 053 92 36102

Website: www.iconsupport.eu

E-mail: csuk@iconeurope.com

Write:

ICON Health & Fitness, Ltd.

Unit 1D, The Gateway

Fryers Way, Silkwood Park

OSSETT

WF5 9TJ

UNITED KINGDOM

AUSTRALIA

Call: 1800 993 770

E-mail: australiacc@iconfitness.com

Write:

ICON Health & Fitness

PO Box 635

WINSTON HILLS NSW 2153

AUSTRALIA

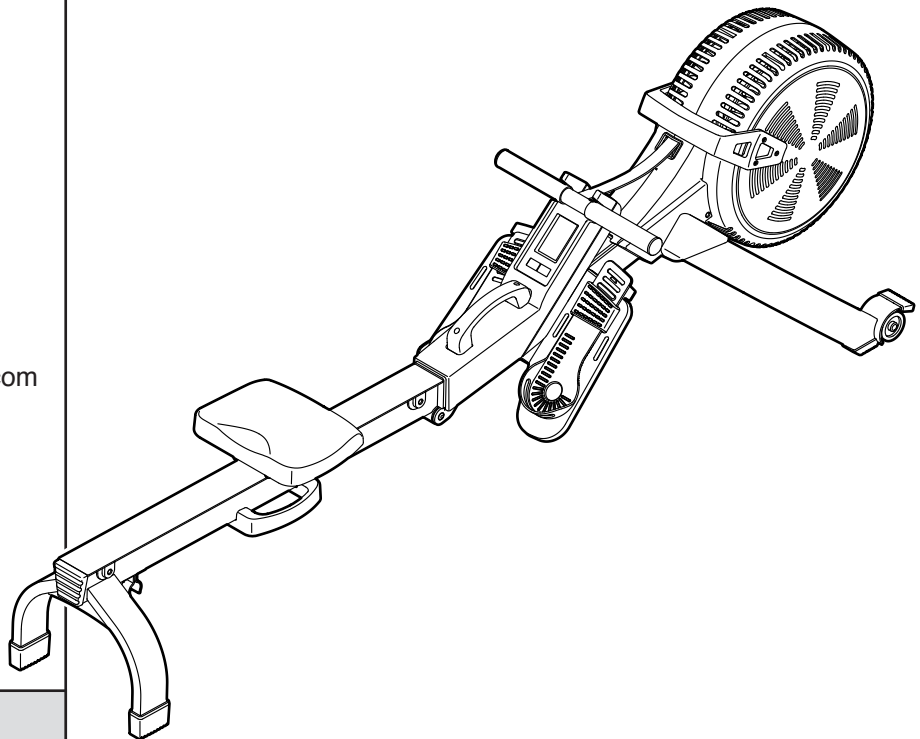

⚠ CAUTION

Read all precautions and instructions in this manual before using this equipment. Keep this manual for future reference.

www.iconsupport.eu

TABLE OF CONTENTS

WARNING DECAL PLACEMENT	2
IMPORTANT PRECAUTIONS	3
BEFORE YOU BEGIN	4
ASSEMBLY	5
HOW TO USE THE ROWER	8
HOW TO USE THE CONSOLE	11
MAINTENANCE AND TROUBLESHOOTING	12
EXERCISE GUIDELINES	13
PART LIST	14
EXPLODED DRAWING	15
ORDERING REPLACEMENT PARTS	Back Cover
RECYCLING INFORMATION	Back Cover

WARNING DECAL PLACEMENT

This drawing shows the location(s) of the warning decal(s). **If a decal is missing or illegible, see the front cover of this manual and request a free replacement decal. Apply the decal in the location shown.** Note: The decal(s) may not be shown at actual size.

⚠ WARNING

- Misuse of this machine may result in serious injury.
- Read user's manual prior to use and follow all warnings and instructions.
- Do not allow children on or around machine.
- User weight must not exceed 115 kg/253 lbs.
- Not intended for therapeutic use.
- This product should always be used on a level surface.
- Replace label if damaged, illegible, or removed.



⚠ WARNING
Keep hands and fingers clear of this area.

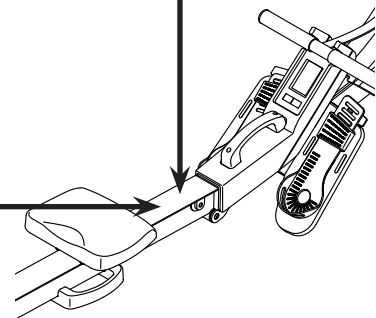

IMPORTANT PRECAUTIONS

⚠️ WARNING: To reduce the risk of serious injury, read all important precautions and instructions in this manual and all warnings on the rower before using the rower. ICON assumes no responsibility for personal injury or property damage sustained by or through the use of this product.

1. It is the responsibility of the owner to ensure that all users of the rower are adequately informed of all precautions.
 2. Before beginning any exercise program, consult your physician. This is especially important for persons over age 35 or persons with pre-existing health problems.
 3. The rower is not intended for use by persons with reduced physical, sensory, or mental capabilities or lack of experience and knowledge, unless they are given supervision or instruction about use of the rower by someone responsible for their safety.
 4. Use the rower only as described in this manual.
 5. The rower is intended for home use only. Do not use the rower in a commercial, rental, or institutional setting.
 6. Keep the rower indoors, away from moisture and dust. Do not put the rower in a garage or covered patio, or near water.
 7. Place the rower on a level surface, with a mat beneath it to protect the floor or carpet.
 8. Inspect and properly tighten all parts each time the rower is used. Replace any worn parts immediately.
 9. Keep children under age 13 and pets away from the rower at all times.
 10. Wear appropriate clothes while exercising; do not wear loose clothes that could become caught on the rower. Always wear athletic shoes for foot protection.
 11. The rower should not be used by persons weighing more than 253 lbs. (115 kg).
 12. Always keep your back straight while using the rower; do not arch your back.
 13. Do not release the row bar while the bungee is extended.
 14. Over exercising may result in serious injury or death. If you feel faint, if you become short of breath, or if you experience pain while exercising, stop immediately and cool down.
- Make sure that there is at least 2 ft. (0.6 m) of clearance around the rower.

BEFORE YOU BEGIN

Thank you for selecting the new PROFORM® R 600 rower. Rowing is an effective exercise for increasing cardiovascular fitness, building endurance, and toning the body. The R 600 rower is designed to let you enjoy this effective exercise in the convenience and privacy of your home.

For your benefit, read this manual carefully before you use the rower. If you have questions after reading

this manual, please see the front cover of this manual. To help us assist you, note the product model number and serial number before contacting us. The model number and the location of the serial number decal are shown on the front cover of this manual.

Before reading further, please review the drawing below and familiarize yourself with the labeled parts.

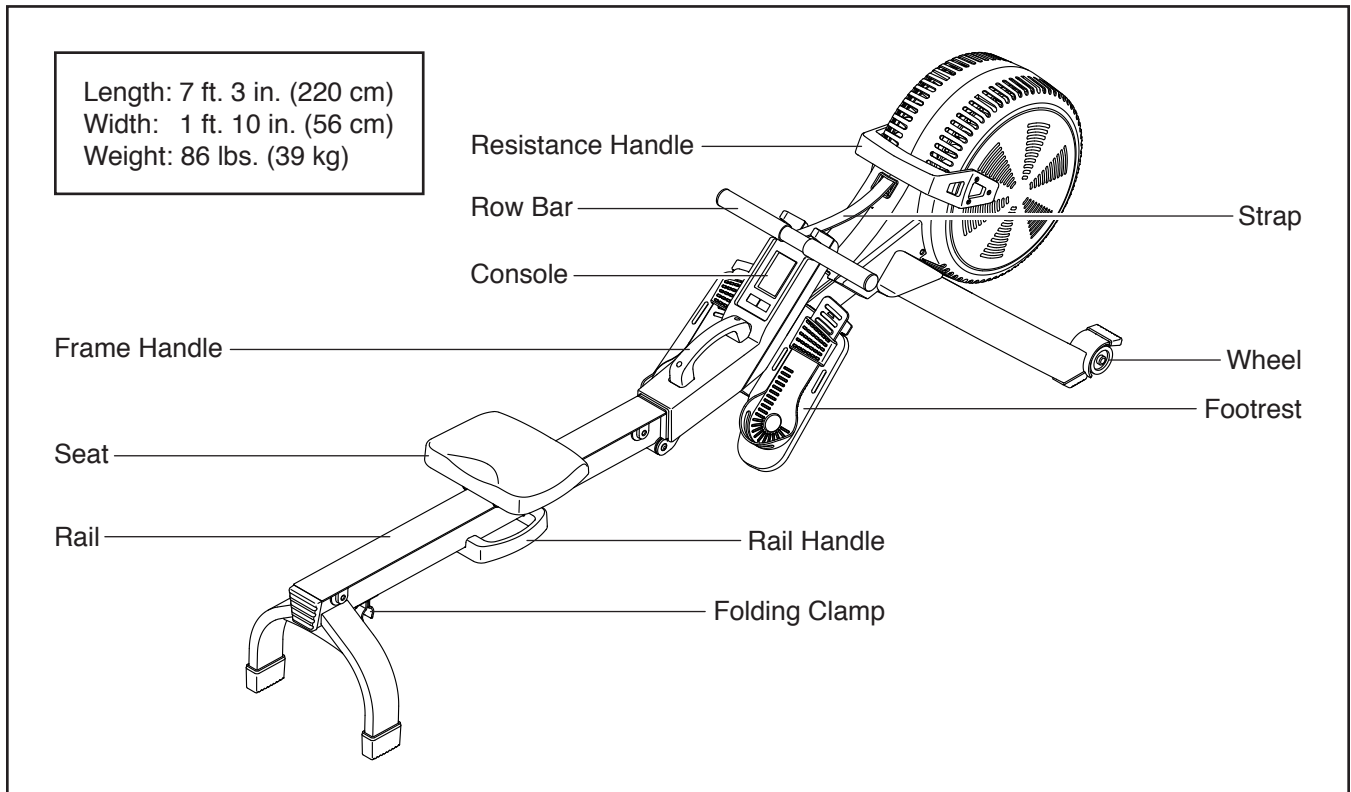

ASSEMBLY

- Assembly requires two persons.
- Place all parts in a cleared area and remove the packing materials. Do not dispose of the packing materials until you finish all assembly steps.

- Assembly requires the following tool(s):

one Phillips screwdriver

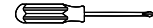

one adjustable wrench



To avoid damaging parts, do not use power tools.

1. Go to www.iconsupport.eu on your computer and register your product.

- activates your warranty
- saves you time if you ever need to contact Customer Service
- allows us to notify you of upgrades and offers

Note: If you do not have internet access, call Customer Service (see the front cover of this manual) and register your product.

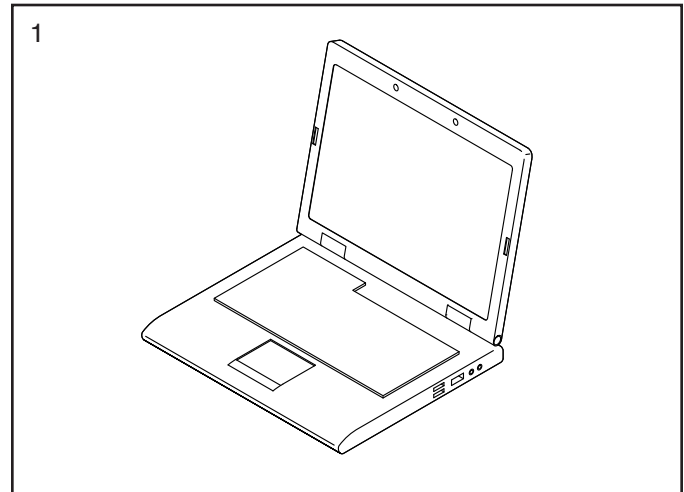

2. If there are shipping tubes (not shown) attached to the rower, remove and discard the shipping tubes and the hardware attaching them.

With the help of a second person, pull the Rail (2) outward and rotate the Stabilizer (3) downward.

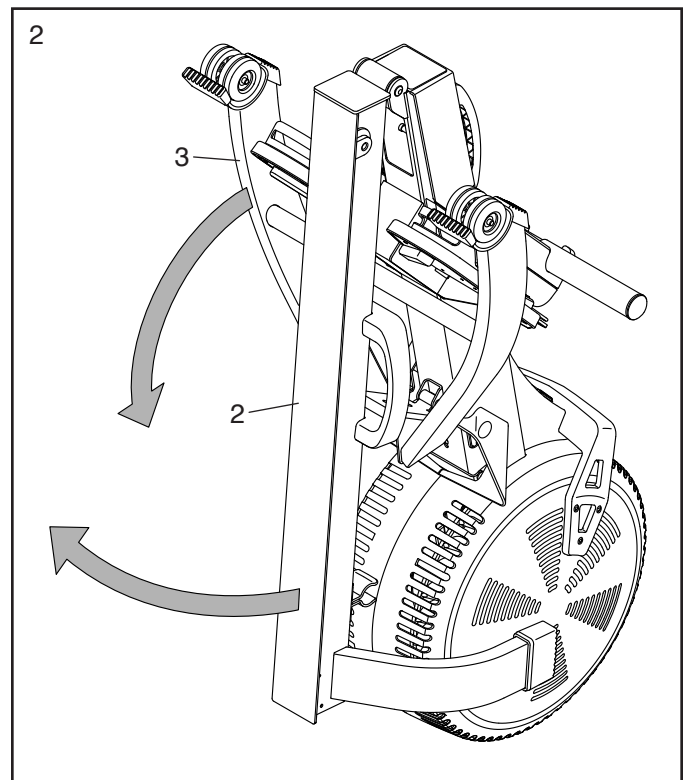

3. **Have a second person hold the Rail (2) during this step.**

Attach the Stabilizer (3) to the Frame (1) with two M10 x 20mm Screws (61).

Then, hold the Rail Handle (34), pull the Rail (2) outward, and set the Rail on the floor.

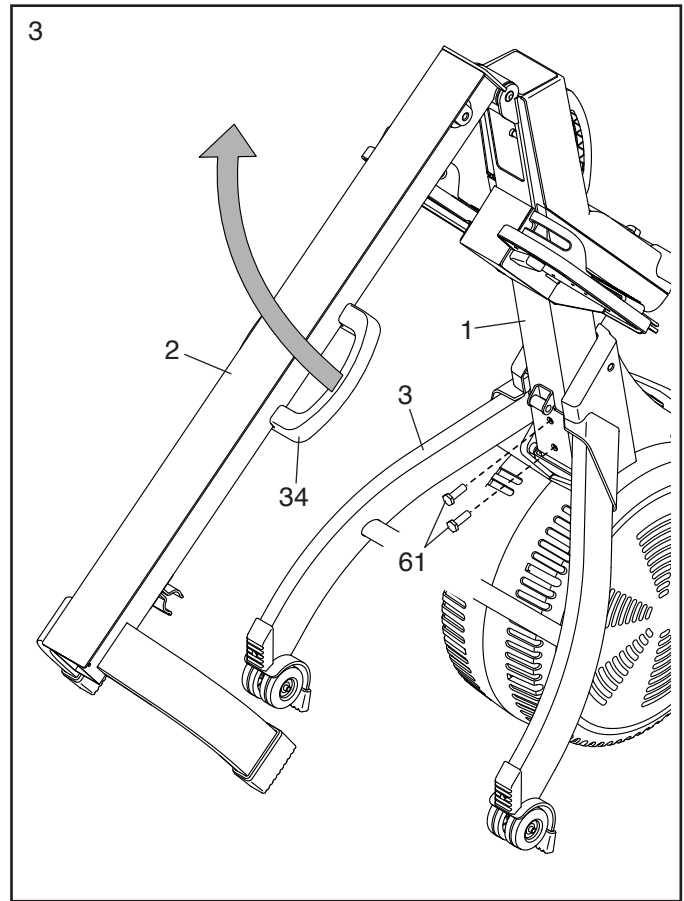

4. Orient the Seat (23) as shown, and slide the Seat Carriage (5) onto the Rail (2).

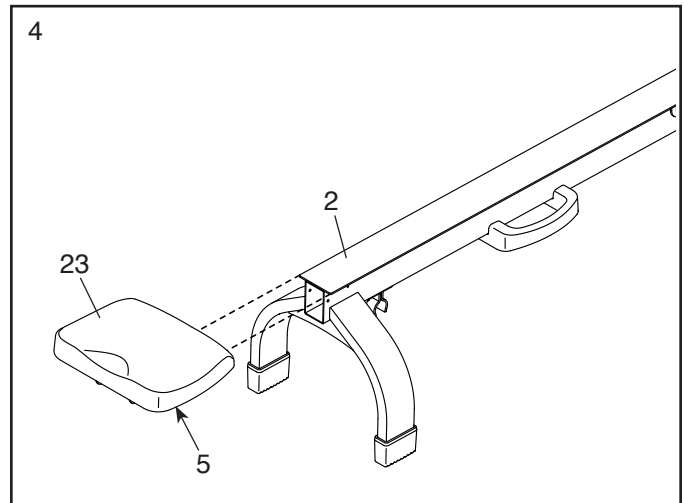

- Slide the Seat (23) to the front of the Rail (2).

Next, attach a Stop (32) to each side of the Rail (2) with an M4 x 19mm Screw (69).

Then, attach the Rail Cap (38) to the Rail (2) with two M4 x 19mm Screws (69).

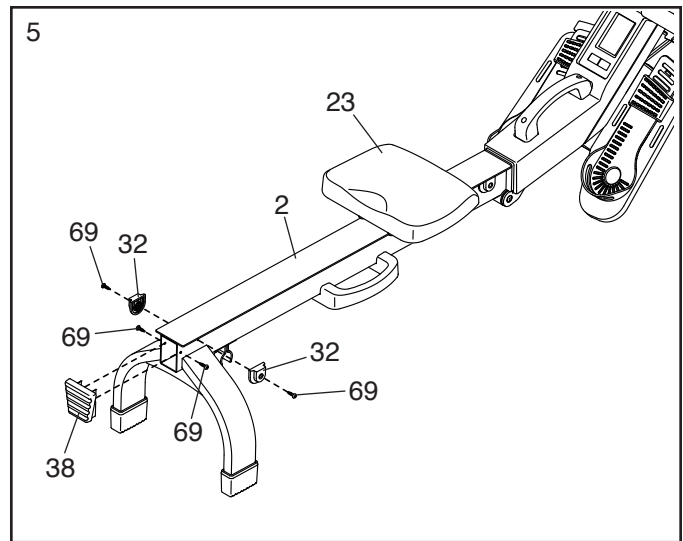

- The Console (51) requires four AA batteries (not included); alkaline batteries are recommended. Do not use old and new batteries together or alkaline, standard, and rechargeable batteries together. **IMPORTANT: If the Console has been exposed to cold temperatures, allow it to warm to room temperature before you insert batteries. Otherwise, you may damage the display or other electronic components.**

Remove the screw (A) and the battery cover (B) from the top of the Console (51). Then, pull out the battery holder (C) and insert batteries (D) into the battery holder; **make sure to orient the batteries as shown by the diagram inside the battery holder.** Then, reinsert the battery holder and reattach the battery cover.

See the inset drawing. Make sure that the batteries (D) are facing upward and that the contacts (E) on the battery holder (C) are facing downward when you insert the battery holder.

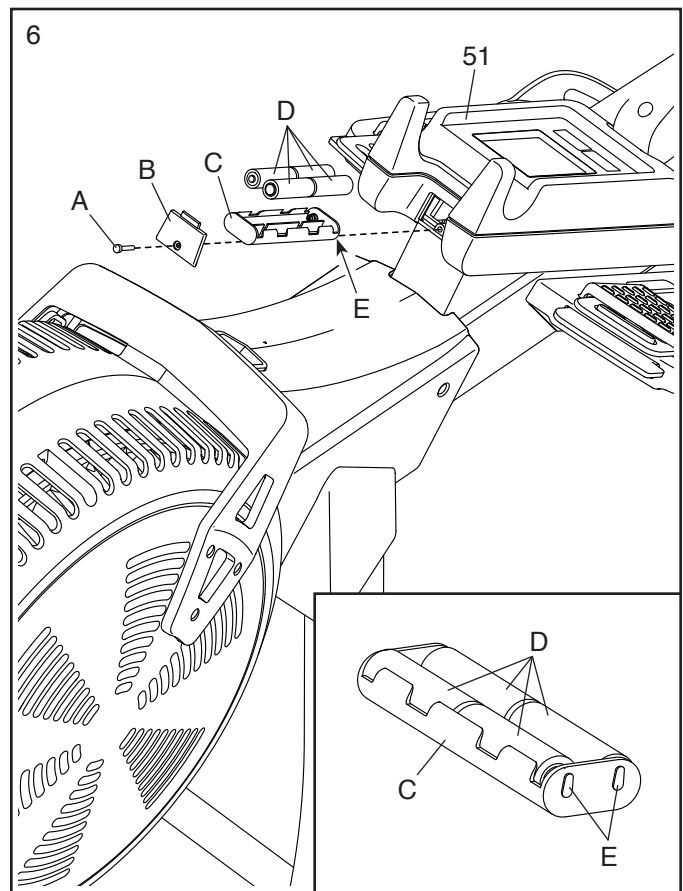

- Make sure that all parts are properly tightened before you use the rower.** Extra parts may be included. Place a mat under the rower to protect the floor.

HOW TO USE THE ROWER

HOW TO ADJUST THE RESISTANCE

To vary the intensity of your exercise, you can adjust the resistance that you feel when you pull the row bar. **To increase the resistance**, move the resistance handle toward the front of the rower; **to decrease the resistance**, move the resistance handle toward the rear of the rower.

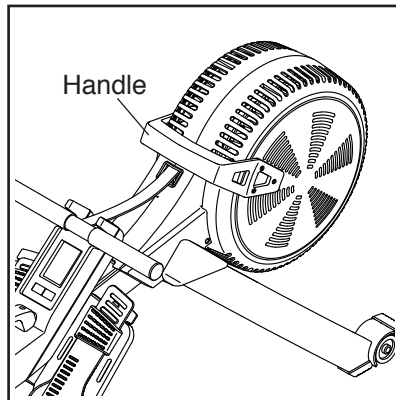

HOW TO ADJUST THE FOOT PADS

First, sit on the seat and place your feet in the foot pads.

Next, press the footrest bracket, slide the foot pad to the desired position, and then release the footrest bracket so that the tab engages a slot in the foot pad. Then, tighten the strap over your foot.

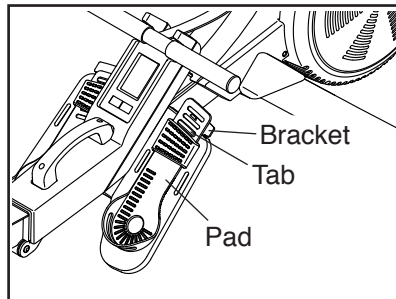

Adjust the other foot pad in the same way. Make sure to adjust both foot pads to the same position.

HOW TO MOVE THE ROWER IN THE UNFOLDED POSITION

Stand behind the rower and lift the rail until the rower will roll on the wheels. Then, carefully move the rower to the desired location, and lower the rail to the floor.

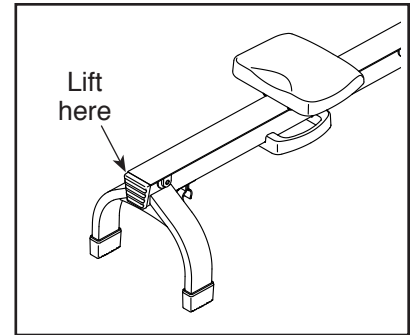

HOW TO MOVE THE ROWER IN THE FOLDED POSITION

See HOW TO FOLD AND STORE THE ROWER on page 9, and fold the rower. Then, hold the frame handle, place your foot on a stabilizer foot, and tip the rower until it will roll on the wheels. Carefully move the rower to the desired location, and then tip it into the storage position.

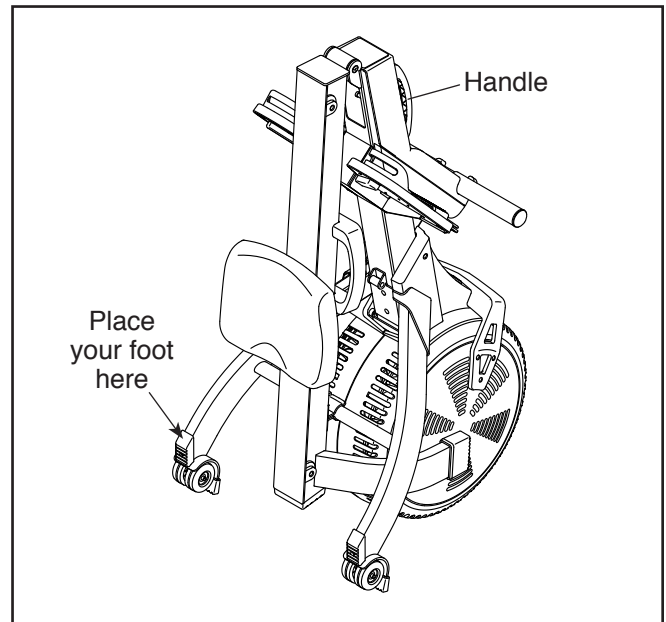

HOW TO FOLD AND STORE THE ROWER

The rower can be stored in a folded position to conserve space. Store the rower in a location where children cannot tip it. Remove the batteries from the console when storing the rower for extended periods of time.

To store the rower, first slide the Seat (23) to the rear of the Rail (2).

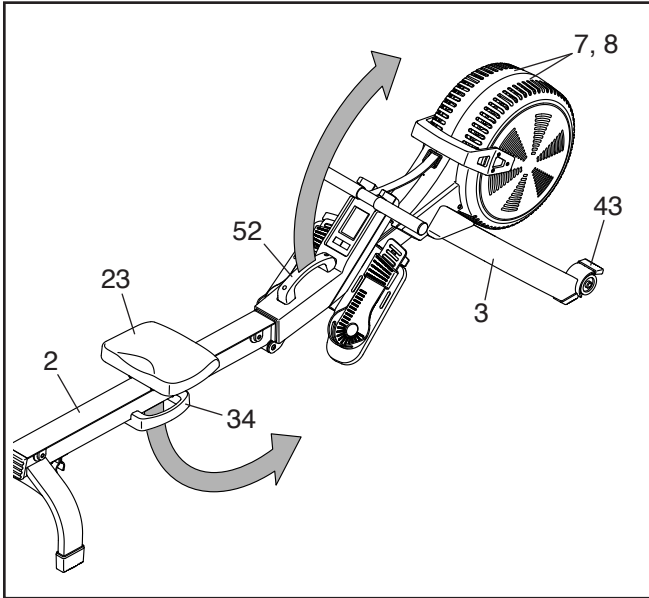

Next, hold and lift the Frame Handle (52) and the Rail Handle (34), and tip the rower forward onto the Shields (7, 8) and the Storage Feet (43).

Then, pull the Rail Handle (34) inward until the Folding Clamp (35) engages the bar on the Stabilizer (3).

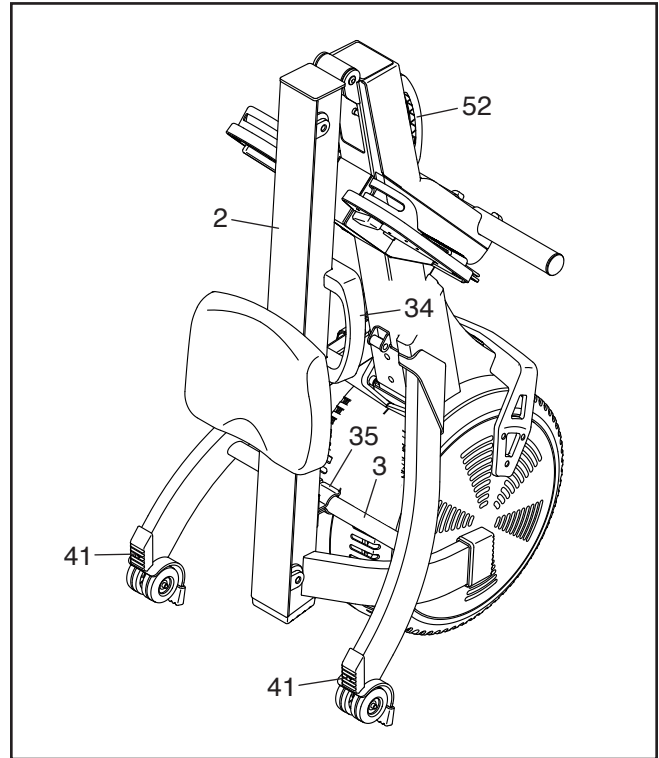

To unfold the rower, first place your foot on a Stabilizer Foot (41) and pull the Rail Handle (34) outward to disengage the Folding Clamp (35).

Then, hold the Rail Handle (34) and the Frame Handle (52), pull the Rail Handle outward, and lower the Rail (2) to the floor.

HOW TO ROW ON THE ROWER

Sit on the seat, place your feet in the footrests, and adjust the straps to fit your feet. Then, hold the row bar with an overhand grip.

Correct rowing form consists of three phases:

1. **The first phase is the CATCH.** Slide the seat forward until your knees are almost touching your chest. Pull the row bar until your hands are directly above your feet.
2. **The second phase is the DRIVE.** Push backward with your legs. Lean back slightly at the hips (not

at the waist), keeping your back straight. As you straighten your legs, pull the row bar toward your chest. Keep your elbows outward.

3. **The third phase is the FINISH.** Your legs should be nearly straight. Continue to pull the row bar until your hands are even with your chest.

After the finish phase, extend your arms forward and pull the seat forward using your legs. Repeat this sequence, moving through all three phases with a smooth, fluid motion. Remember to breathe normally as you row; never hold your breath.

HOW TO USE THE CONSOLE

FEATURES OF THE CONSOLE

The easy-to-use console features several modes that provide instant exercise feedback during your workouts. The modes are described below.

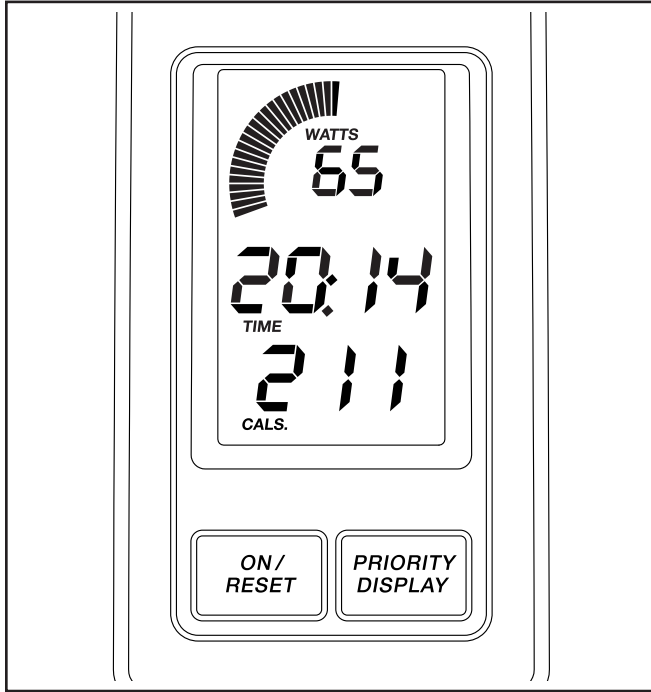

Watts—This mode shows your approximate power output in watts.

Strokes Per Minute (SPM)—This mode shows the number of rowing strokes you are completing per minute.

Time—This mode shows the elapsed time.

Strokes—This mode shows the number of rowing strokes you have completed during your workout.

Calories—This mode shows the approximate number of calories you have burned during your workout.

Scan—This mode shows the watts, strokes per minute, time, and strokes modes for a few seconds each in a repeating cycle.

HOW TO USE THE CONSOLE

Make sure that batteries are installed in the console (see assembly step 6 on page 7). If there is a sheet of clear plastic on the console, remove the plastic.

1. Turn on the console.

To turn on the console, press the On/Reset button on the console or simply begin rowing.

2. Begin rowing and follow your progress with the displays.

Upper display—This display will show the watts mode and the strokes per minute mode.

Center display—This display will show the time mode and the strokes mode.

Lower display—This display will show the calories mode.

The scan mode will be selected automatically when you turn on the console.

To view the watts, strokes per minute, time, or strokes mode for continuous display, press the Priority Display button repeatedly until the desired mode is shown in the display.

To return to the scan mode, press the Priority Display button repeatedly until the word SCAN appears in the center display.

To reset the displays to zero, press the On/Reset button.

3. When you are finished exercising, the console will turn off automatically.

If the row bar does not move for a few seconds, the console will pause.

The console has an auto-off feature. If the row bar does not move and the console buttons are not pressed for a few minutes, the power will turn off automatically to save the batteries.

MAINTENANCE AND TROUBLESHOOTING

MAINTENANCE

Regular maintenance is important for optimal performance and to reduce wear. Inspect and properly tighten all parts each time the rower is used. Replace any worn parts immediately.

To clean the rower, use a damp cloth and a small amount of mild detergent. **IMPORTANT: To avoid damage to the console, keep liquids away from the console and keep the console out of direct sunlight.**

For best results, clean the rail, the seat carriage, and the carriage rollers daily.

CONSOLE TROUBLESHOOTING

Most console problems are the result of low batteries; for replacement instructions, see assembly step 6 on page 7.

HOW TO ADJUST THE REED SWITCH

If the console does not display correct feedback, the reed switch should be adjusted.

To adjust the reed switch, you must remove the resistance handle and the right and left shields as described below.

First, remove the six M4 x 10mm Screws (70), and then gently remove the Resistance Handle (9).

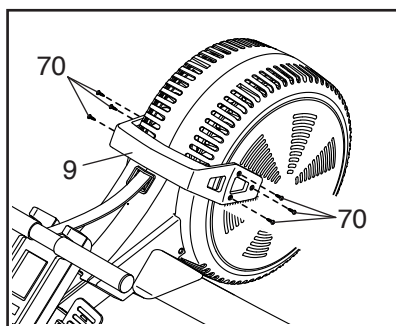

See the **EXPLODED DRAWING** on page 15.

Locate the Right and Left Shields (7, 8), and remove the four M4 x 19mm Screws (69) and the ten M4 x 16mm Screws (68) from the Right and Left Shields. Then, gently remove the Right and Left Shields.

Then, locate the Reed Switch (47). Turn the Left Fan (4) until a Magnet (77) is aligned with the Reed Switch. Loosen, but do not remove, the two indicated M4 x 19mm Screws (69). Then, slide the Reed Switch slightly closer to or away from the Magnet, and retighten the Screws.

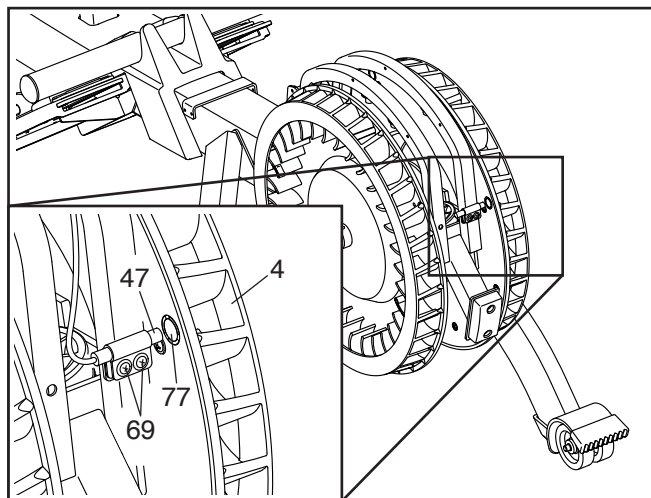

Turn the Left Fan (4) so that the Magnet (77) passes the Reed Switch (47) repeatedly. Repeat these actions until the console displays correct feedback.

When the reed switch is correctly adjusted, reattach the parts that you removed.

EXERCISE GUIDELINES

⚠️ WARNING: Before beginning this or any exercise program, consult your physician. This is especially important for persons over age 35 or persons with pre-existing health problems.

These guidelines will help you to plan your exercise program. For detailed exercise information, obtain a reputable book or consult your physician. Remember, proper nutrition and adequate rest are essential for successful results.

EXERCISE INTENSITY

Whether your goal is to burn fat or to strengthen your cardiovascular system, exercising at the proper intensity is the key to achieving results. You can use your heart rate as a guide to find the proper intensity level. The chart below shows recommended heart rates for fat burning and aerobic exercise.

165	155	145	140	130	125	115	♥️
145	138	130	125	118	110	103	♥️
125	120	115	110	105	95	90	♥️
<hr/>							
20	30	40	50	60	70	80	

To find the proper intensity level, find your age at the bottom of the chart (ages are rounded off to the nearest ten years). The three numbers listed above your age define your “training zone.” The lowest number is the heart rate for fat burning, the middle number is the heart rate for maximum fat burning, and the highest number is the heart rate for aerobic exercise.

Burning Fat—To burn fat effectively, you must exercise at a low intensity level for a sustained period of time. During the first few minutes of exercise, your body uses carbohydrate calories for energy. Only after the first few minutes of exercise does your body begin to use stored fat calories for energy. If your goal is to burn fat, adjust the intensity of your exercise until your heart rate is near the lowest number in your training zone. For maximum fat burning, exercise with your heart rate near the middle number in your training zone.

Aerobic Exercise—If your goal is to strengthen your cardiovascular system, you must perform aerobic exercise, which is activity that requires large amounts of oxygen for prolonged periods of time. For aerobic exercise, adjust the intensity of your exercise until your heart rate is near the highest number in your training zone.

HOW TO MEASURE YOUR HEART RATE

To measure your heart rate, exercise for at least four minutes. Then, stop exercising and place two fingers on your wrist as shown. Take a six-second heartbeat count, and multiply the result by 10 to find your heart rate. For example, if your six-second heartbeat count is 14, your heart rate is 140 beats per minute.

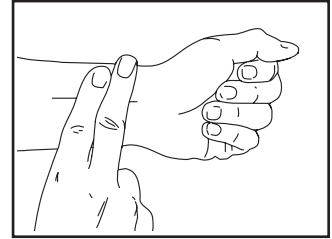

WORKOUT GUIDELINES

Warming Up—Start with 5 to 10 minutes of stretching and light exercise. A warm-up increases your body temperature, heart rate, and circulation in preparation for exercise.

Training Zone Exercise—Exercise for 20 to 30 minutes with your heart rate in your training zone. (During the first few weeks of your exercise program, do not keep your heart rate in your training zone for longer than 20 minutes.) Breathe regularly and deeply as you exercise; never hold your breath.

Cooling Down—Finish with 5 to 10 minutes of stretching. Stretching increases the flexibility of your muscles and helps to prevent post-exercise problems.

EXERCISE FREQUENCY

To maintain or improve your condition, complete three workouts each week, with at least one day of rest between workouts. After a few months of regular exercise, you may complete up to five workouts each week, if desired. Remember, the key to success is to make exercise a regular and enjoyable part of your everyday life.

PART LIST

Model No. PFEVRW41016.0 R0916A

Key No.	Qty.	Description	Key No.	Qty.	Description
1	1	Frame	46	2	Roller Axle
2	1	Rail	47	1	Reed Switch/Wire
3	1	Stabilizer	48	1	Frame Pulley
4	1	Left Fan	49	1	Frame Foot
5	1	Seat Carriage	50	1	Reed Switch Clamp
6	2	Deflector	51	1	Console/Row Bar Rest
7	1	Right Shield	52	1	Frame Handle
8	1	Left Shield	53	1	Pivot Axle
9	1	Resistance Handle	54	12	Deflector Bracket
10	1	Grommet	55	2	Pulley Bracket
11	1	Bungee	56	6	6mm Washer
12	1	Strap	57	11	M6 Locknut
13	1	Row Bar	58	3	M8 Washer
14	2	Grip	59	2	M8 x 12mm Screw
15	2	Row Bar Cap	60	1	M10 x 40mm Bolt
16	2	Footrest Strap	61	2	M10 x 20mm Screw
17	1	Right Footrest	62	8	5mm Washer
18	1	Right Foot Pad	63	8	M5 x 10mm Screw
19	1	Right Footrest Bracket	64	2	#8 x 3/4" Screw
20	1	Left Footrest Bracket	65	12	M6 x 15mm Screw
21	1	Left Footrest	66	2	M10 Flange Nut
22	1	Left Foot Pad	67	2	Clip
23	1	Seat	68	12	M4 x 16mm Screw
24	2	Small Bearing	69	32	M4 x 19mm Screw
25	4	Snap Ring	70	6	M4 x 10mm Screw
26	1	Bushing	71	10	M6 x 12mm Screw
27	2	Large Bearing	72	1	Right Fan
28	2	15mm Wave Washer	73	4	8mm Washer
29	1	Pulley Assembly	74	1	One-way Bearing
30	1	Axle	75	4	M8 Locknut
31	2	Pivot Bushing	76	12	M4 x 10mm Screw
32	4	Stop	77	4	Fan Magnet
33	1	Bumper	78	2	Bearing Bracket
34	1	Rail Handle	79	1	Handle Bracket
35	1	Folding Clamp	80	1	Link Arm
36	2	Rail Foot	81	1	Magnet Bracket
37	2	Small Carriage Roller	82	1	Resistance Magnet
38	1	Rail Cap	83	1	Frame Magnet
39	2	Large Carriage Roller	84	4	Magnet Screw
40	2	Carriage Axle	85	2	Handle Bracket Screw
41	2	Stabilizer Foot	86	2	M6 x 12mm Hex Screw
42	4	Wheel	87	1	M8 x 12mm Hex Screw
43	2	Storage Foot	88	2	M6 Washer
44	5	Rail Pulley	*	-	User's Manual
45	2	Strap Roller	*	-	Assembly Tool

Note: Specifications are subject to change without notice. For information about ordering replacement parts, see the back cover of this manual. *These parts are not illustrated.

EXPLODED DRAWING

Model No. PFEVRW41016.0 R0916A

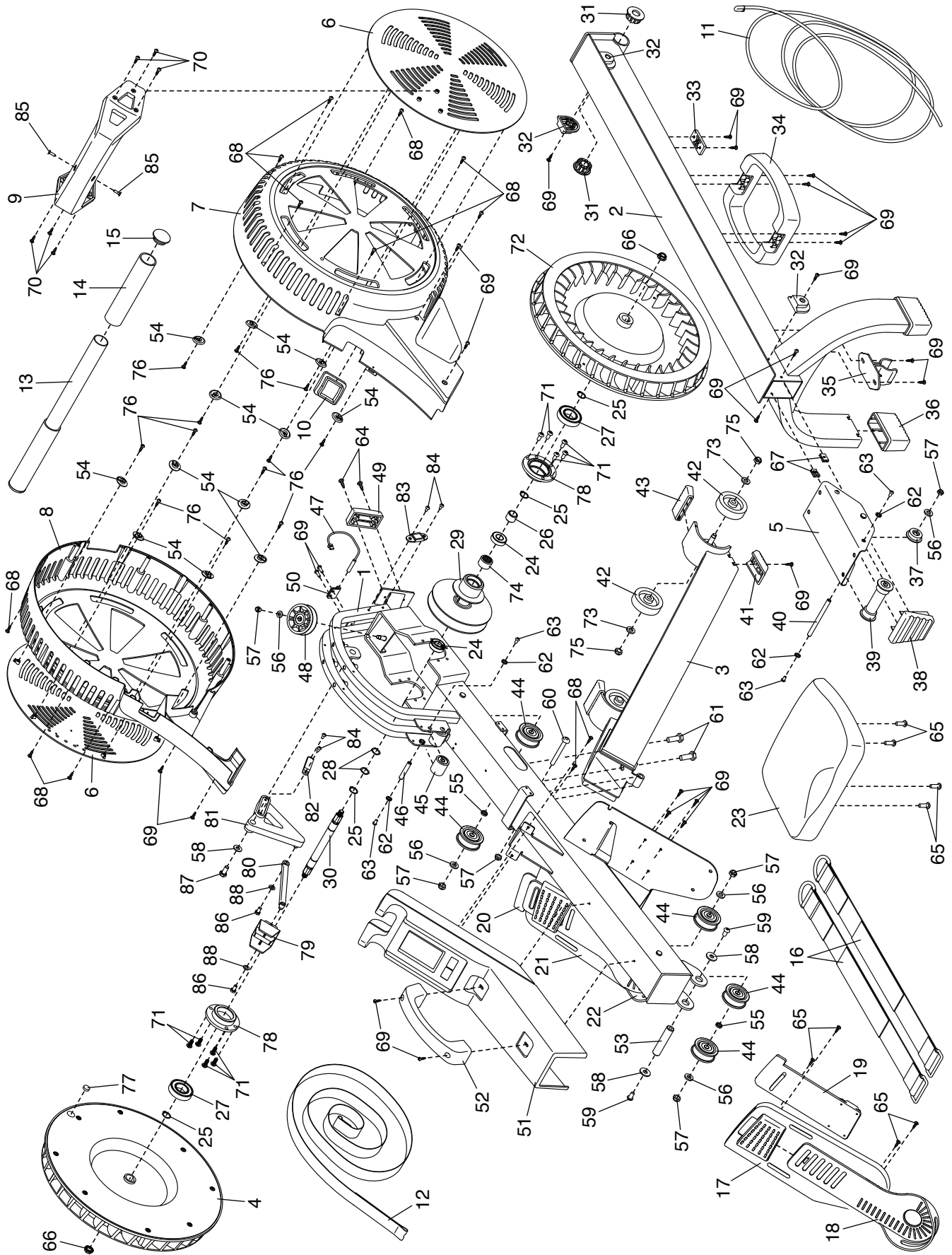

ORDERING REPLACEMENT PARTS

To order replacement parts, please see the front cover of this manual. To help us assist you, be prepared to provide the following information when contacting us:

- the model number and serial number of the product (see the front cover of this manual)
- the name of the product (see the front cover of this manual)
- the key number and description of the replacement part(s) (see the PART LIST and the EXPLODED DRAWING near the end of this manual)

RECYCLING INFORMATION

This electronic product must not be disposed of in municipal waste. To preserve the environment, this product must be recycled after its useful life as required by law.

Please use recycling facilities that are authorized to collect this type of waste in your area. In doing so, you will help to conserve natural resources and improve European standards of environmental protection. If you require more information about safe and correct disposal methods, please contact your local city office or the establishment where you purchased this product.

