

SENCOR®

SWS 2900

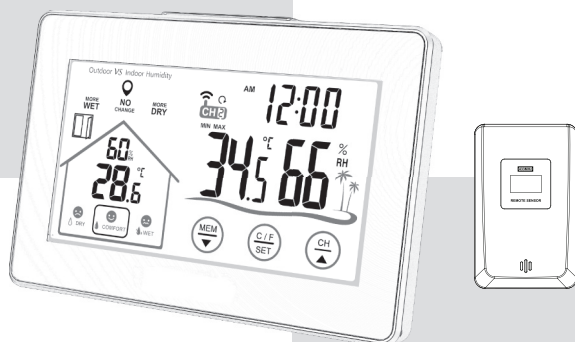

User's manual

Návod k obsluze

Návod na obsluhu

Használati útmutató

Instrukcja obsługi

IN/OUT DOOR THERMOMETER WITH HUMIDITY

METEOSTANICE

METEOSTANICA

METEOROLÓGIAI ÁLLOMÁS

STACJA METEOROLOGICZNA

EN CZ SK HU PL

OVERVIEW

MAIN UNIT

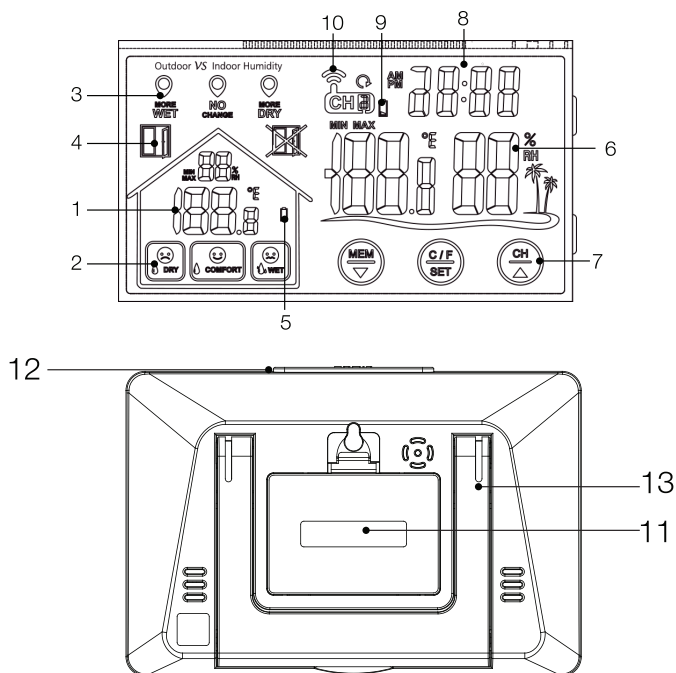

1. Indoor temperature and humidity
2. Comfort level indicator
3. Ambient change indicator
4. Window Indicator
5. Low battery (indoor sensor)
6. Outdoor temperature and humidity
7. Touch button
8. Current time
9. Low battery (outdoor sensor)
10. Transmitter channel
11. Battery compartment cover
12. Backlight button
13. Stand Bracket

OUTDOOR SENSOR

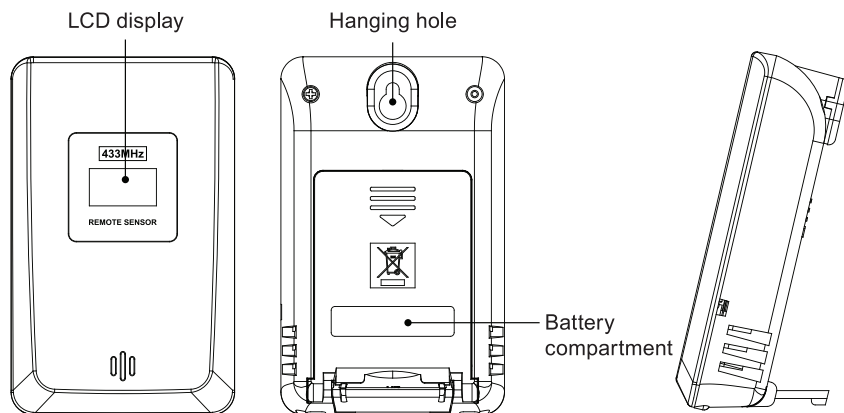

FEATURES

1. Window open/close indicator
2. Touch buttons for easy operation
3. Indoor and outdoor temperature
4. Indoor and outdoor humidity
5. Records max/min temperature and humidity (in and out)
6. Comfort level indicator
7. Low battery indicator
8. Time display in 12/24h
9. White backlight
10. 100 meters wireless transmitter in open area

GETTING STARTED

POWER SUPPLY

MAIN UNIT INSTALLATION

1. Remove the battery compartment cover.
2. Insert 3× AAA battery matching the polarity (+and-).

SENSOR INSTALLATION

1. Remove the battery compartment cover.
2. Insert 2×AAA batteries matching the polarity (+and-).

Initialization

1. After power on, LCD will full display for 3 seconds, and in the meanwhile hygrometer will detect indoor temperature & humidity, and then it will starting to receive outdoor signal which last for max 3 minutes.
2. Temperature default: °C
3. Time display default: 24HR

TIME SET

Operation \ Function		MEM/▼	°C / °F / SET	CH/▲	LIGHT
Stand Ard Mode	Press	Check max record	Switch C/F	Switch Channel	Backlight on
	Hold	Clear max record	Enter into time set mode	RF re-registration	_____
Time Setting Mode	Press	Decrease	Confirm and go next	Increase	_____
	Hold	Decrease in 8 steps	_____	Increase in 8 steps	_____

1. Press and hold “°C/°F/SET” button to enter into time setting.
2. Hour and minute will flash. Press “CH/▲” to increase and “MEM/▼” to decrease the setting.
3. The setting order is: Hour → Minute → 24/12H → OFF/ON (Memory mode 24hour or all the time) → Exit
4. Press “°C/°F/SET” to confirm the setting

MAX AND MIN RECORD

1. Press “MEM/▼” first time to have maximum temperature and humidity, the value will display for 5 seconds.
2. Press “MEM/▼” second time to have the minimum temperature and humidity, the value will display for 5 seconds.
3. Press “MEM/▼” third time will return to standard mode.
4. Press and hold “MEM/▼” will clear the max and min record and reactive the memory again.
5. User can select the MEM time limit, see point 3 in TIME SET section.
6. ON means the record will record last 24 hours, will auto clear and re-start record at 0:00; OFF means the record will last all the time from power on.



OUTDOOR CHANNEL

1. Hygrometer will auto receive outdoor signal after power on, the receiving status will last for max 3 minutes, the receiving antenna signal will flash, if no signal received in 3 minutes, will not exist and stop receiving outdoor signal.
2. Press “CH/▲” button to change the channel
3. The setting order is CH1 --> CH2--> CH3 --> Channel scan (from CH1 to CH2 to CH3, 10 seconds intervals)
4. Press and hold “CH/▲” button for more than 3 seconds to manually enter into RF re-registration, press and hold “CH/▲” button for 3 seconds again will exit RF registration
5. The current outdoor temperature and humidity data will be cleared during re-registration status

Remark:

- a. If hygrometer have received outdoor data successfully before, in next 60 minutes if lost signal, the hygrometer outdoor area will display “-.-”
- b. For multi-channels (on condition you buy more than one sensor), you need to pair the sensor one by one. Before matching the certain channel, please power the sensor and switch the sensor to the same channel as main unit.

COMFORT LEVEL INDICATOR

Display			
Humidity	DRY 20%~44%	COMFORT 45%~65%	WET 66%~95%

1. Dry: when indoor humidity between 20%~44%, include 20% and 44%
2. Comfort: when indoor humidity range is 45%~65%, include 45% and 65%
3. Wet: when indoor humidity between 66%~95%, include 66% and 99%





AMBIENT CHANGE ICON

Ambient change is calculated by the outdoor and indoor absolute humidity. Icons will be changed on screen on below conditions:

Absolute humidity Difference (Out VS In)	Display
Within +/-0.8g/m ³	NO CHANGE
Above +0.8g/m ³	MORE WET
Below -0.8g/m ³	MORE DRY

WINDOW INDICATOR

On certain humidity conditions (as below chart shows), the window indicator on screen will show up for a reference of opening/closing the windows.

Humidity Comfort Level   	Ambient Change <small>MORE WET</small> <small>NO CHANGE</small> <small>MORE DRY</small>	Open Window 	Close Window 
comfort	More Dry or More Wet or No change	Off	Off
Dry	No Change	Off	Off
Dry	More Wet	On	Off
Dry	More Dry	Off	On
Wet	No Change	Off	Off
Wet	More Wet	Off	On
Wet	More Dry	On	Off

PRECAUTIONS

- Do not clean any part of the product with benzene, thinner or other solvent chemicals. When necessary, clean it with a soft cloth.
- Never immerse the product in water. This can cause electrical shock and damage the product.
- Do not subject the product to extreme force, shock, or fluctuations in temperature or humidity.
- Do not tamper with the internal components.
- Do not mix new and old batteries or batteries of different types.
- Do not mix alkaline, standard or rechargeable batteries with this product. Remove the batteries if storing this product for a long period of time.
- Do not dispose of this product as unsorted municipal waste. Collection of such waste separately for special treatment is necessary.

INSTRUCTIONS AND INFORMATION REGARDING THE DISPOSAL OF USED PACKAGING MATERIALS

Dispose of packaging material at a public waste disposal site.

DISPOSAL OF USED ELECTRICAL AND ELECTRONIC APPLIANCES



The meaning of the symbol on the product, its accessory or packaging indicates that this product shall not be treated as household waste. Please, dispose of this product at your applicable collection point for the recycling of electrical & electronic equipment waste. Alternatively in some states of the European Union or other European states you may return your products to your local retailer when buying an equivalent new product. The correct disposal of this product will help save valuable natural resources and help in preventing the potential negative impact on the environment and human health, which could be caused as a result of improper liquidation of waste. Please ask your local authorities or the nearest waste collection centre for further details. The improper disposal of this type of waste may fall subject to national regulations for fines.

For business entities in the European Union

If you wish to dispose of an electrical or electronic device, request the necessary information from your seller or supplier.

Disposal in other countries outside the European Union

If you wish to dispose of this product, request the necessary information about the correct disposal method from local government departments or from your seller.



The product meets EU requirements.

Changes to the text, design and technical specifications may occur without prior notice and we reserve the right to make these changes.

The original version is in the Czech language.

Address of the manufacturer: FAST ČR, a.s., Černokostelecká 1621, Říčany CZ-251 01

Hereby, FAST ČR, a.s. declares that the radio equipment type SWS 2900 is in compliance with Directive 2014/53/EU. The full text of the EU declaration of conformity is available at the following internet address: www.sencor.eu.

SENCOR®

EN Warranty conditions

Warranty card is not a part of the device packaging.

This product is warranted for the period of 24 months from the date of purchase to the end-user. Warranty is limited to the following conditions. Warranty is referred only to the customer goods using for common domestic use. The claim for service can be applied either at dealer's shop where the product was bought, or at below mentioned authorized service shops. The end-user is obligated to set up a claim immediately when the defects appeared but only till the end of warranty period. The end user is obligated to cooperate to certify the claiming defects. Only completed and clean (according to hygienic standards) product will be accepted. In case of eligible warranty claim the warranty period will be prolonged by the period from the date of claim application till the date of taking over the product by end-user, or the date the end-user is obligated to take it over. To obtain the service under this warranty, end-user is obligated to certify his claim with duly completed following documents: receipt, certificate of warranty, certificate of installation.

This warranty is void especially if apply as follows:

- Defects which were put on sale.
- Wear-out or damage caused by common use.
- The product was damaged by unprofessional or wrong installation, used in contrary to the applicable instruction manual, used in contrary to legal enactment and common process of use or used for another purpose which has been designed for.
- The product was damaged by uncared-for or insufficient maintenance.
- The product was damaged by dirt, accident of force majeure (natural disaster, fire, and flood).
- Defects on functionality caused by low duality of signal, electromagnetic field interference etc.
- The product was mechanically damaged (e.g. broken button, fall).
- Damage caused by use of unsuitable media, fillings, expendable supplies (batteries) or by unsuitable working conditions (e.g. high temperatures, high humidity, quakes).
- Repair, modification or other failure action to the product by unauthorized person.
- End-user did not prove enough his right to claim (time and place of purchase).
- Data on presented documents differs from data on products.
- Cases when the claiming product cannot be indentified according to the presented documents (e.g. the serial number or the warranty seal has been damaged).

Authorized service centers

Visit www.sencor.eu for detailed information about authorized service centers.