

OPERATING INSTRUCTIONS

AIR COOLER

with remote control

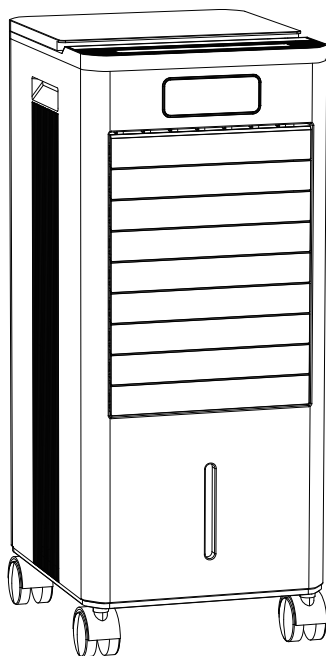

READ ALL INSTRUCTIONS BEFORE USING

PRODUCT DESCRIPTION	2
PRODUCT PARAMETERS	3
CONTROL PANEL INSTRUCTIONS.....	3-4
OPERATION METHODS	4-6
CLEANING AND STORAGE	7
SAFETY AND WARNING	7
TYPES OF FAILURES AND SOLUTION	8

PRODUCT DESCRIPTION

MAIN DEVICE

HORIZONTAL LOUVERS

WIND OUTLET

Snap-lock Caster Wheel

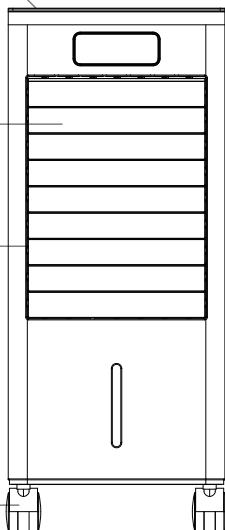

TOP WATER FILLER

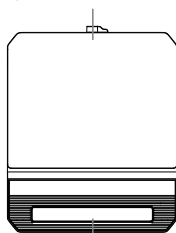

CONTROL PANEL AND DISPLAY



ICE BOXES

POWER SWITCH

WATER LEVEL INDICATOR
MIN-MAX

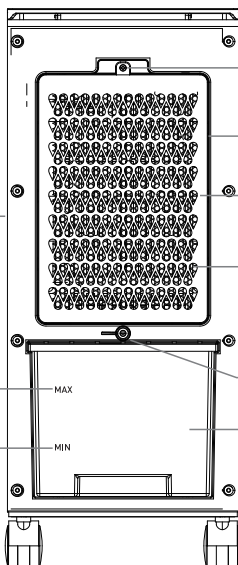

HONEYCOMB PANEL LOCKING KNOBS

FRAME COVER

HONEYCOMB PANEL FRAME

HONEYCOMB PANEL

WATER TANK LOCKING KNOB

WATER TANK

PRODUCT PARAMETERS

Model	FK2306Y
Rated Voltage	120v~
Rated Frequency	50/60Hz
Rated Power	65W
Water Tank Capacity	4.5L-7L
Rated Evaporation Capacity	0.3-0.5L/H
Wind Speed	Low Speed, Medium Speed, High Speed
Maximum Wind Speed	6m/s
Mode	Normal Mode, Natural Mode, Sleep Mode
Swing Angle	Left-Right 60°(Automatic). Up-Down 120°(Manual)
Timing Function	1-12Hours
Remote Control Distance	26ft

CONTROL PANEL INSTRUCTIONS

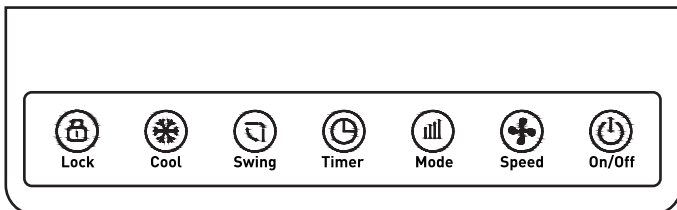

Plug into a power outlet, you will hear the buzzer “beeps” once, and the machine enters the standby state.

On/Off:
Press the “On/Off” button to turn it on, the wind is low-speed and the wind type is “normal”. Press this button again to turn the machine off.

Mode:
When the product is in working, touch “Mode” one time or more times, the corresponding icon will be light up and the mode is cycled as follows:



Speed:
Touch “Speed” one time or more times, the wind speed is cycled as follows:

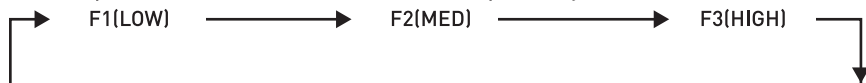

 **Swing:**
Touch "Swing" one time or more times, automatic horizontal swing will be start or stop , corresponding indicator light will be on or off.

 **Cool:**
Touch "Cool", cool function start work and indicator light will be light up.

 **Timer:**
When the unit is working, touch "Timer" one time or more times, timer will be cycled as follows:



 **Child lock button:**
The first time you press "" keys, except "" All keys except the key will be locked and cannot be controlled; only press again "" key to unlock and restore control.

Note:

The machine comes with a screen-off function. If the machine is not operated within 3 minutes, the display will automatically turn off.

OPERATION METHODS

① When using the appliance, make sure that it is on a flat and stable surface. Damage may occur if it is placed on an incline or decline. If you need cooler more, add ice block into upper water slot, see following image:

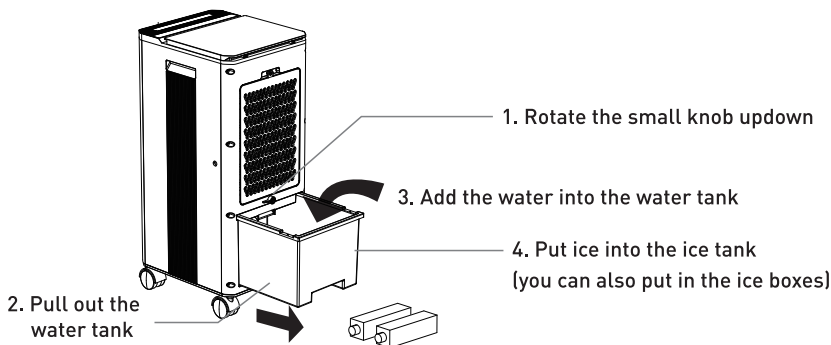

Note: the ice box should be far way from children to avoid eating

② Insert the plug directly into a standard AC socket-outlet. Be sure plug fits tightly into outlet.

③ “COOLING” Touch

Note:

don't use this button without water, to avoid damage to parts.

Press the button, the water pump start to work, the wind will be cooler and wet.

3-1 Before operating the unit in Cool mode, make sure the escape valve for the water tank is properly fixed. Then proceed to add clean water into the water tank. While adding the water, make sure that you keep an eye on the water level indicator to make sure that you do not OVER or UNDER FILL the unit. Press the button Cool after you have added the water and the unit should commence to blow cooler air. When you press the button Cool again, it will stop working.

3-2 If you find that the air after Step 1) is still not cool enough, you can add additional ice block into the water tank directly by opening the water tank cover. Be sure not to exceed the icebox capacity otherwise damage to the unit or electric shock may occur.

3-3 If you wish to use an Ice box instead of ice block, just place it directly into the tank by opening the water door. It will be good cooling efficiency if you place it in your refrigerator and let the ice pack freeze for 1 to 2 hours.

3-4 You may complete pull out water tank, then replace water in the water tank or clean water tank.

④ How to knock down the dust-proof bracket and honeycomb filter.

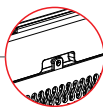
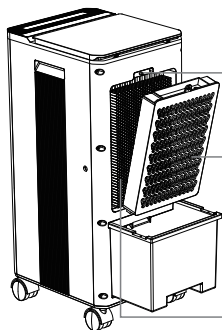

1. Rotate the small knob updown

2. Pull out the frame cover.

3. Take out the Honeycomb panel frame.

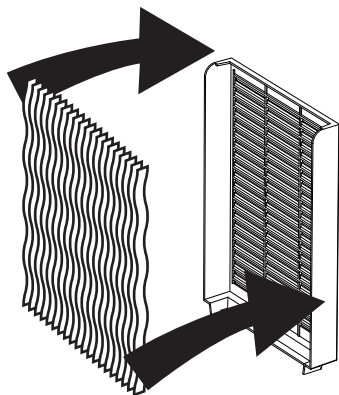

REMOTE CONTROL INSTRUCTIONS

The remote control of the cooling fan and the buttons on the control panel all use touch switches, which can be operated with a light touch, and the functions of the buttons are the same as those on the control panel.

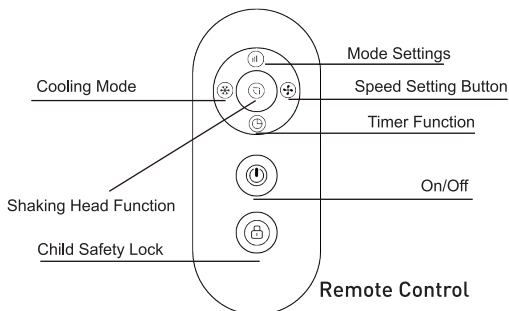

Precautions for using the remote control:

- ① The remote control of this product has been equipped with batteries, pull out the insulating card before use and keep it properly.
- ② The remote control should face the front of the air cooler, and the effective range is about 6 meters. If there is an obstacle in the middle or it is not facing the front of the air cooler, its effective range will be reduced or invalid.
- ③ Please keep the remote control properly to avoid impact and drop.
- ④ If the remote control is not used for a long time, please insert the insulating card into the remote control.

How to use the ice crystals:

The product is equipped with 4 ice boxes, which contain ice crystals.

- ① Please add water to the maximum water level(MAX) in the ice crystal box and tighten it, then place it at natural temperature for 1-2 hours.
- ② Put the ice crystal box filled with water into the refrigerator to freeze, and wait for it to harden. Put the ice crystal box into the upper water tank and turn on the "COOL" mode.

Note:

- ① Do not eat the ice product in the box!
- ② It is best to freeze for about 6 hours for the first use.

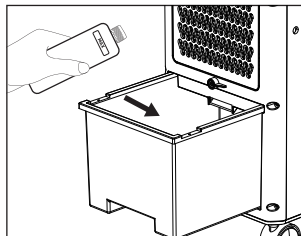
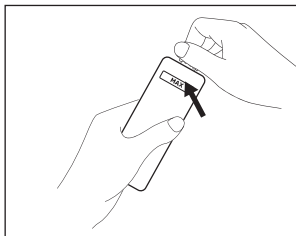
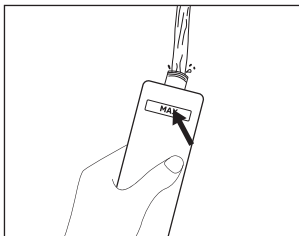

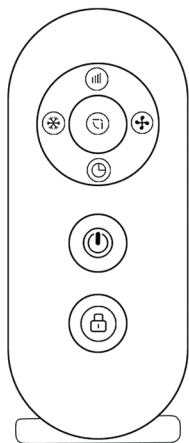

① Remove the insulating strip

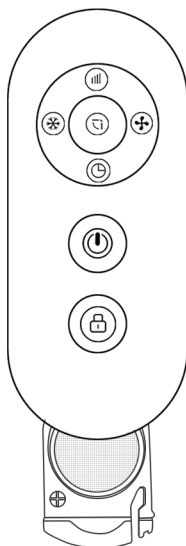

④ Reinsert the battery holder

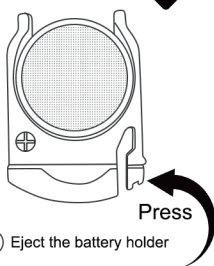

② Eject the battery holder

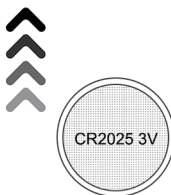

③ Replace the battery

1. It is necessary to unplug the insulating plastic piece at the bottom of the remote control before the remote control can be powered on and used normally.
2. Press the locking button to pop out the battery holder.
3. Replace with the same battery (CR2025 3V) type with the (+) side facing up.
4. Push in the holder until securely locked into place.

Note: If the indicator on the remote control doesn't turn on any more, please consider replacing the battery.

CLEANING AND STORAGE

- ① Always remove the plug from the socket-outlet and allow the fan blower to stop acting before clean it.
- ② Clean the external surfaces of the unit with a soft damp (not dripping wet) cloth.
- ③ After extended periods of use, be sure to replace the water in the tank with fresh clean water at least weekly. Also remember to clean the filter by unscrewing the filter and removing the filter cradle. It should be cleaned in a mild soapy solution and then left to dry before replacing the filter.
- ④ When the unit is not in use, make sure that it is unplugged from the wall socket, water is drained thoroughly and it is placed back into its original box for storage until later use.
- ⑤ In case of malfunction or doubt, do not try to repair the fan yourself, it may result in a fire hazard or electric shock.

SAFETY AND WARNING

- ① The product is for household use only.
- ② Connect the appliance to single-phase AC supply of the voltage specified on the rating label.
- ③ Always turn the product to the OFF position and unplug it from the electrical outlet when not in use.
- ④ Extreme caution is necessary when the appliance is used by or near children, invalids or elderly person.
- ⑤ Do not run cord under carpeting and do not cover cord with throw rugs, runners or the like. Arrange cord away from traffic area and where it will not be tripped over.
- ⑥ Do not operate the appliance with a damaged cord or plug, or after the unit malfunctions, has been dropped, or damaged in any manner.
- ⑦ If the supply cord is damaged, it must be replaced by the manufacturer or its service agent or a similarly qualified person to avoid a hazard.
- ⑧ Use the appliance in a well-ventilated area. While using, distance of no less than 20cm should be kept away from wall or corner to ensure the air intakes or exhaust openings should not be blocked unexpectedly. The unit must not be located immediately below or besides a curtain or the likes.
- ⑨ Do not insert or allow fingers or any other objects into grill to avoid a mechanical danger when in use. Do not block air intakes or exhaust openings in any manner.
- ⑩ Adequate clean water should be put into the tank within the water level limits as shown by the water level indicator. Make sure that you DO NOT add water whilst the power is on.
- ⑪ If you want to move the product whilst water is in the tank, unplug it and push it slowly and very lightly on the side of the unit to avoid water spillage. The best method would be to drain the unit using the valve at the bottom of the unit.
- ⑫ Please keep the ice crystals box provided away from children, as it is a chemical based substance that is harmful if swallowed. Also make sure that the ice pack is not placed in direct sunshine. The ice crystal can be used over 5 years. When scrapping the appliance, follow the regulations concerning the disposal of ice crystals.
- ⑬ Use the appliance on flat, dry floor only.
- ⑭ This appliance is not intended for use by persons (including children) with reduced physical, sensory or mental capabilities, or lack of experience and knowledge, unless they have been given supervision or instruction concerning use of the appliance by a person responsible for their safety.
- ⑮ Children should be supervised to ensure that they do not play with the appliance.

TYPES OF FAILURES AND SOLUTION

Problem	Reason	Solution
The machine does not work, and indicator light does not light	<ol style="list-style-type: none"> 1.The socket is broken; 2.The plug and socket have been loosened; 3.The machine was damaged during transportation. 	<ol style="list-style-type: none"> 1.Replace a socket; 2.Plug tight; 3.Contact the seller.
The effect is not good after turn on the "COOL" mode	<ol style="list-style-type: none"> 1.The water level is too low; 2.The suction pipe of the water pump is blocked; 3.The water inlet above the wet curtain is blocked; 4.The wet curtain is not installed correctly, causing the water to flow back to the tank; 5.Relative humidity of the environment is high. 	<ol style="list-style-type: none"> 1.Add water; 2.Clean the water pipe; 3.Clean the water inlet above the wet curtain; 4.Install the wet curtain correctly; 5.When the relative humidity is lower than 75%, the cooling effect is most effective;
The air volume of the machine is very small	<ol style="list-style-type: none"> 1.The fan is in natural wind and sleep wind mode 2.Air flow at the air inlet is blocked; 3.Insufficient supply voltage. 	<ol style="list-style-type: none"> 1.Adjust the "MODE"; 2.Remove items behind the machine to ensure proper air circulation; 3.Ensure that the home circuit is stable; contact the seller.
Can not be controlled by the remote control	<ol style="list-style-type: none"> 1.The battery is dead; 2.The remote control is not pointed at the sensor on the machine or the sensor is blocked. 	<ol style="list-style-type: none"> 1.Replace the battery; 2.Make sure the channel between the remote control and the machine sensor is not blocked by furniture or other objects.

Installation instructions

1

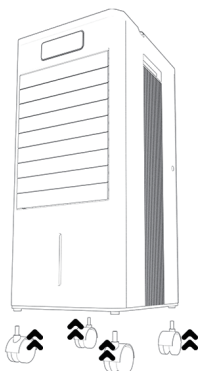

All four wheels are equipped with clip-locks, enhancing the stability of the air cooler.

2

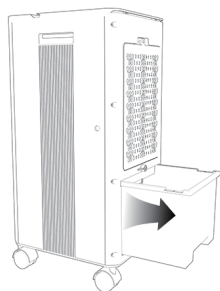

The water tank of the air cooler can be pulled out two-thirds of the way for water replacement or cleaning, but be careful not to disconnect the pump's wiring.

3

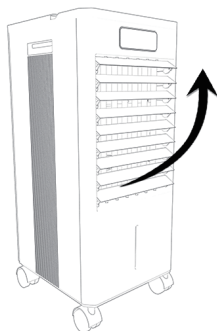

The panel of the air conditioners outlet can be opened and closed manually, but the Angle of the single piece cannot be adjusted, only the whole can be adjusted

Installation instructions

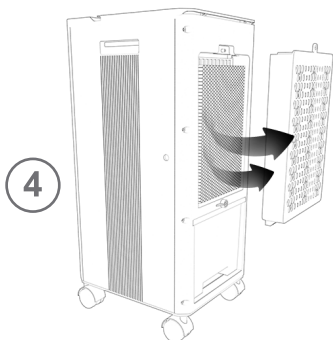

All four wheels are equipped with clip-locks, enhancing the stability of the air cooler.

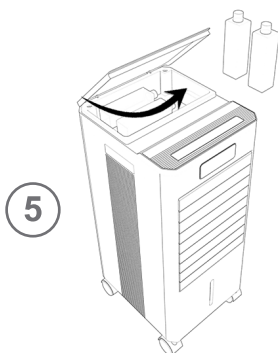

The top compartment of the air cooler is designed for ice crystal bottles. We provide four bottles in total: use two at a time and keep the other two as replacements.

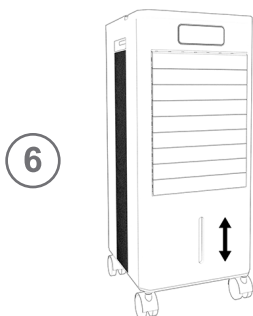

This transparent bar is the water level line, need to pay attention to this water level when using, once the water level drops to the lowest line, you need to add water