

SEARS

OWNER'S MANUAL

MODEL NOS.
315.175040
315.175050
315.175060

⚠ CAUTION:
Read and follow
ALL safety rules
and instructions
before operating
this equipment.

SAVE THIS
MANUAL FOR
FUTURE REFERENCE

Thank You for Buying A
Craftsman Router

MODEL NO. 315.175040

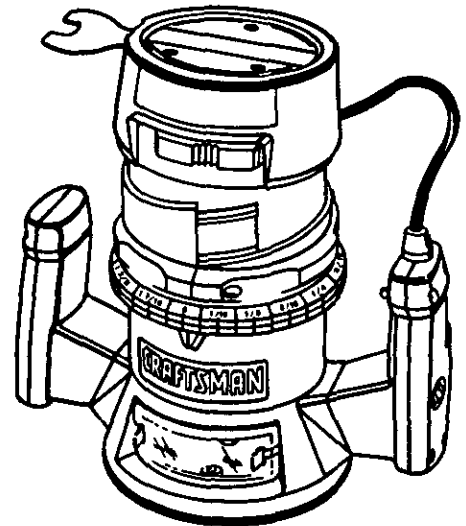
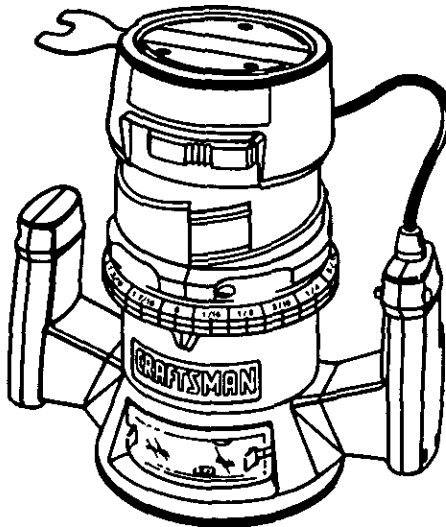

MODEL NO. 315.175050

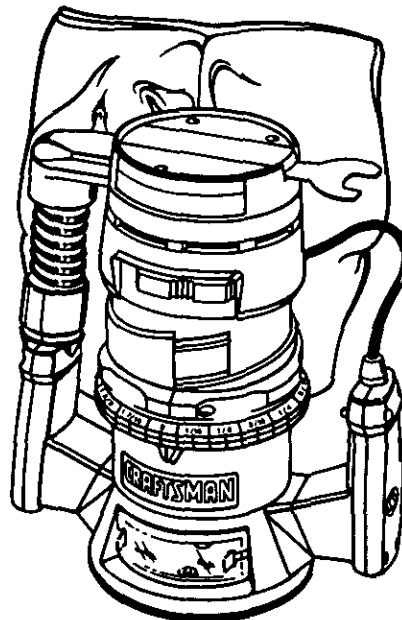

MODEL NO. 315.175060

CRAFTSMAN[®]

Router

Double Insulated

Warranty
Rules For Safe Operation
Table Of Contents
Introduction
Unpacking

Features
Operation
Maintenance
Accessories
Repair Parts



SEARS, ROEBUCK AND CO., Hoffman Estates, IL 60179 U.S.A.

FULL ONE YEAR WARRANTY ON CRAFTSMAN ROUTER

If this Craftsman Router fails to give complete satisfaction within one year from the date of purchase, **RETURN IT TO THE NEAREST SEARS STORE IN THE UNITED STATES**, and Sears will repair it, free of charge.

If this Craftsman Router is used for commercial or rental purposes, this warranty applies for only 90 days from the date of purchase.

This warranty gives you specific legal rights, and you may also have other rights which vary from state to state.

Sears, Roebuck and Co., DEPT. 817 WA, Hoffman Estates, IL 60179

RULES FOR SAFE OPERATION

The purpose of safety symbols is to attract your attention to possible dangers. The safety symbols, and their explanations with them, deserve your careful attention and understanding. The safety warnings do not by themselves eliminate any danger. The instructions or warnings they give are not substitutes for proper accident prevention measures.

SYMBOL	MEANING
	SAFETY ALERT SYMBOL: Indicates caution or warning. May be used in conjunction with other symbols or pictographs.
	WARNING: Failure to obey a safety warning can result in serious injury to yourself or to others. Always follow the safety precautions to reduce the risk of fire, electric shock and personal injury.
	CAUTION: Failure to obey a safety warning may result in property damage or personal injury to yourself or to others. Always follow the safety precautions to reduce the risk of fire, electric shock and personal injury.
NOTE:	Advises you of information or instructions vital to the operation or maintenance of the equipment.

**SAFETY ALERT SYMBOL:**

Indicates caution or warning. May be used in conjunction with other symbols or pictographs.



WARNING: Failure to obey a safety warning can result in serious injury to yourself or to others. Always follow the safety precautions to reduce the risk of fire, electric shock and personal injury.



CAUTION: Failure to obey a safety warning may result in property damage or personal injury to yourself or to others. Always follow the safety precautions to reduce the risk of fire, electric shock and personal injury.

NOTE: Advises you of information or instructions vital to the operation or maintenance of the equipment.

DOUBLE INSULATION is a safety concept in electric power tools which eliminates the need for the usual three wire grounded power cord and grounded supply system. Wherever there is electric current in the tool there are two complete sets of insulation to protect the user. All exposed metal parts are isolated from internal metal motor components with protecting insulation.

IMPORTANT - Servicing of a tool with double insulation requires extreme care and knowledge of the system and should be performed only by a qualified service technician. For service we suggest you return the tool to your nearest Sears Store for repair. Always use original factory replacement parts when servicing.

ELECTRICAL CONNECTION

Your router has a precision built electric motor. It should be connected to a **power supply that is 120 volts, 60 Hz, AC only (normal household current)**. Do not operate this tool on direct current (DC). A voltage drop of more than 10 percent will cause a loss of power and the motor will overheat. If your tool does not operate when plugged into an outlet, double-check the power supply.



Look for this symbol to point out important safety precautions. It means attention!!! Your safety is involved.

RULES FOR SAFE OPERATION

WARNING:

Do not attempt to operate this tool until you have read thoroughly and understand completely all instructions, safety rules, etc. contained in this manual. Failure to comply can result in accidents involving fire, electric shock, or serious personal injury. Save owner's manual and review frequently for continuing safe operation, and instructing others who may use this tool.

WARNING:

The double insulated system is intended to protect the user from shock resulting from a break in the tool's internal wiring. Observe all normal safety precautions related to avoiding electrical shock.

READ ALL INSTRUCTIONS

1. **KNOW YOUR POWER TOOL.** Read owner's manual carefully. Learn its applications and limitations as well as the specific potential hazards related to this tool.
2. **GUARD AGAINST ELECTRICAL SHOCK** by preventing body contact with grounded surfaces. For example: Pipes, radiators, ranges, refrigerator enclosures.
3. **KEEP GUARDS IN PLACE** and in working order.
4. **KEEP WORK AREA CLEAN.** Cluttered areas and benches invite accidents.
5. **AVOID DANGEROUS ENVIRONMENT.** Don't use power tool in damp or wet locations or expose to rain. Keep work area well lit.
6. **KEEP CHILDREN AND VISITORS AWAY.** All visitors should wear safety glasses and be kept a safe distance from work area. Do not let visitors contact tool or extension cord.
7. **STORE IDLE TOOLS.** When not in use tools should be stored in a dry and high or locked-up place - out of the reach of children.
8. **DON'T FORCE TOOL.** It will do the job better and safer at the rate for which it was designed.
9. **USE RIGHT TOOL.** Don't force small tool or attachment to do the job of a heavy duty tool. Don't use tool for purpose not intended - for example - A circular saw should never be used for cutting tree limbs or logs.
10. **WEAR PROPER APPAREL.** Do not wear loose clothing or jewelry that can get caught in tool's moving parts and cause personal injury. Rubber gloves and non-skid footwear are recommended when working outdoors. Wear protective hair covering to contain long hair and keep it from being drawn into nearby air vents.
11. **ALWAYS WEAR SAFETY GLASSES.** Everyday eyeglasses have only impact-resistant lenses; they are **NOT** safety glasses.
12. **PROTECT YOUR LUNGS.** Wear a face or dust mask if operation is dusty.
13. **PROTECT YOUR HEARING.** Wear hearing protection during extended periods of operation.
14. **DON'T ABUSE CORD.** Never carry tool by cord or yank it to disconnect from receptacle. Keep cord from heat, oil and sharp edges.
15. **SECURE WORK.** Use clamps or a vise to hold work. Both hands are needed to operate the tool.
16. **DON'T OVERREACH.** Keep proper footing and balance at all times. Do not use on a ladder or unstable support.
17. **MAINTAIN TOOLS WITH CARE.** Keep tools sharp at all times, and clean for best and safest performance. Follow instructions for lubricating and changing accessories.
18. **DISCONNECT TOOLS.** When not in use, before servicing, or when changing attachments, blades, bits, cutters, etc., all tools should be disconnected from power supply.
19. **REMOVE ADJUSTING KEYS AND WRENCHES.** Form habit of checking to see that keys and adjusting wrenches are removed from tool before turning it on.
20. **AVOID ACCIDENTAL STARTING.** Don't carry plugged-in tools with finger on switch. Be sure switch is off when plugging in.
21. **MAKE SURE YOUR EXTENSION CORD IS IN GOOD CONDITION.** When using an extension cord, be sure to use one heavy enough to carry the current your product will draw. An undersized cord will cause a drop in line voltage resulting in loss of power and overheating. A wire gage size (A.W.G.) of at least 14 is recommended for an extension cord 100 feet or less in length. A cord exceeding 100 feet is not recommended. If in doubt, use the next heavier gage. The smaller the gage number, the heavier the cord.

RULES FOR SAFE OPERATION (Continued)

22. **OUTDOOR USE EXTENSION CORDS.** When tool is used outdoors, use only extension cords suitable for use outdoors. Outdoor approved cords are marked with the suffix W-A, for example - SJTW-A or SJOW-A.
23. **KEEP CUTTERS CLEAN AND SHARP.** Sharp cutters minimize stalling and kickback.
24. **KEEP HANDS AWAY FROM CUTTING AREA.** Keep hands away from cutters. Do not reach underneath work while cutter is rotating. Do not attempt to remove material while cutter is rotating.
25. **NEVER USE IN AN EXPLOSIVE ATMOSPHERE.** Normal sparking of the motor could ignite fumes.
26. **INSPECT TOOL CORDS PERIODICALLY** and if damaged, have repaired at your nearest Sears Repair Center. Stay constantly aware of cord location.
27. **INSPECT EXTENSION CORDS PERIODICALLY** and replace if damaged.
28. **KEEP HANDLES DRY, CLEAN, AND FREE FROM OIL AND GREASE.** Always use a clean cloth when cleaning. Never use brake fluids, gasoline, petroleum-based products or any strong solvents to clean your tool.
29. **STAY ALERT.** Watch what you are doing and use common sense. Do not operate tool when you are tired. Do not rush.
30. **CHECK DAMAGED PARTS.** Before further use of the tool, a guard or other part that is damaged should be carefully checked to determine that it will operate properly and perform its intended function. Check for alignment of moving parts, binding of moving parts, breakage of parts, mounting, and any other conditions that may affect its operation. A guard or other part that is damaged should be properly repaired or replaced by an authorized service center unless indicated elsewhere in this instruction manual.
31. **DO NOT USE TOOL IF SWITCH DOES NOT TURN IT ON AND OFF.** Have defective switches replaced by an authorized service center.
32. **INSPECT FOR** and remove all nails from lumber before routing.
33. **DRUGS, ALCOHOL, MEDICATION.** Do not operate tool while under the influence of drugs, alcohol, or any medication.
34. **WHEN SERVICING USE ONLY IDENTICAL CRAFTSMAN REPLACEMENT PARTS.**
35. **POLARIZED PLUGS.** To reduce the risk of electric shock, this tool has a polarized plug (one blade is wider than the other). This plug will fit in a polarized outlet only one way. If the plug does not fit fully in the outlet, reverse the plug. If it still does not fit, contact a qualified electrician to install the proper outlet. Do not change the plug in any way.
36. **DO NOT USE TOOL UNDER "BROWN-OUT" OR OTHER LOW VOLTAGE CONDITIONS.** Also, do not use with any device that could cause the power supply voltage to change.
37. **WHEN USING THIS ROUTER WITH A ROUTER TABLE, HELP PREVENT POSSIBLE SERIOUS INJURY BY KEEPING THE CUTTER GUARDED AT ALL TIMES.** Use only router tables, with guards, that have been designed for use on routers that are of this type, size, and weight.
38. **SAVE THESE INSTRUCTIONS.** Review them frequently and use them to instruct others who may use this tool. If you loan someone this tool, loan them these instructions also.



WARNING:

Some dust created by power sanding, sawing, grinding, drilling, and other construction activities contains chemicals known to cause cancer, birth defects or other reproductive harm. Some examples of these chemicals are:

- lead from lead-based paints,
- crystalline silica from bricks and cement and other masonry products, and
- arsenic and chromium from chemically-treated lumber.

Your risk from these exposures varies, depending on how often you do this type of work. To reduce your exposure to these chemicals: work in a well ventilated area, and work with approved safety equipment, such as those dust masks that are specially designed to filter out microscopic particles.

TABLE OF CONTENTS

■ Warranty	2	Proper Feeding	14
■ Rules For Safe Operation	2-4	Speed Selections (Model Nos. 315.175050 and 315.175060 Only)	14
■ Table Of Contents	5	Rate Of Feed	14
■ Introduction and Product Specifications	6	Force Feeding	14
■ Unpacking	7	Too Slow Feeding.....	14
■ Features	7-9	Depth Of Cut.....	15
Switch	7	Direction Of Feed and Thrust	15
Lock-On Button.....	7	Routing	15
Chip Shield	7	Starting and Ending A Cut Internal Routing.....	16
Wrench Storage Area	7	Edging With Pilot Bits	16
Variable Speed (Model Nos. 315.175050 and 315.175060 Only)	7	Edge Routing	16
Dust Bag Assembly (Model No. 315.175060 Only)	7	Routing With Guide Bushings.....	17
To Install Dust Bag	7	Router Tables	17
To Empty Dust Bag	7	■ Maintenance	17-22
Know Your Router	8	Switch Replacement (Model No. 315.175040)	17
Model No. 315.175040	8	Switch Replacement (Model Nos. 315.175050 and 315.175060)	18
Model No. 315.175050	9	Light Bulb Replacement	19
Model No. 315.175060	9	Proper Care Of Cutters.....	19
■ Operation.....	10-17	Proper Care Of Collet	19
Installing/Removing Cutters.....	10	Lubrication	19
Depth Of Cut Adjustments	11	Helpful Hints	19
Depth Of Cut Adjustments When Mounted To A Router Table	12	General	20
Variable Speed (Model Nos. 315. 175050 and 315.175060)	12	Extension Cords	20
Practice Before Actual Use	12	■ Accessories	21
Routing	13	■ Exploded View and Parts List	22-27
Freehand Routing.....	13	■ Parts Ordering / Service.....	28

INTRODUCTION

Congratulations and thank you for buying this Craftsman router. It has been designed, engineered and manufactured to provide you with Sears high standard of dependability, ease of operation, and operator safety. Properly cared for, it will give you years of rugged, trouble-free performance.

Your router has many features for making routing operations more pleasant and enjoyable. Safety, performance and dependability have been given top priority in the design of this router making it easy to maintain and operate.

CAUTION:

Carefully read through this entire owner's manual before using your new router. Pay close attention to the Rules For Safe Operation, Warnings and Cautions. If you use your router properly and only for what it is intended, you will enjoy years of safe, reliable service.

SPECIFICATIONS:

DEPTH OF CUT	0 - 1-1/2 in.
COLLET	1/4 in.
HORSEPOWER	
Model No. 315.175040	1-1/2
Model No. 315.175050	1-3/4
Model No. 315.175060	2
AMPS	
Model No. 315.175040	8.0
Model No. 315.175050	8.5
Model No. 315.175060	9.0
RATING	120 volts, 60 Hz, AC only
NO LOAD SPEED	
Model No. 315.175040	25,000 RPM
Model Nos. 315.175050 and 315.175060	15,000 - 25,000 RPM
POWER CORD	
Model Nos. 315.175040 and 315.175050	6 ft.
Model No. 315.175060	10 ft.
DUSTLESS	
Model No. 315.175060	
NET WEIGHT	
Model No. 315.175040	8.13 lbs.
Model No. 315.175050	8.14 lbs.
Model No. 315.175060	9 lbs.

WARNING:



The operation of any router can result in foreign objects being thrown into your eyes, which can result in severe eye damage. Before beginning power tool operation, always wear safety goggles or safety glasses with side shields and a full face shield when needed. We recommend Wide Vision Safety Mask for use over eyeglasses or standard safety glasses with side shields, available at Sears Retail Stores.

UNPACKING

Your router has been shipped completely assembled and ready for use. Inspect it carefully to make sure no breakage or damage has occurred during shipping. If any parts are damaged or missing, contact your nearest Sears Retail Store to obtain replacement parts before attempting to operate router. A wrench and this owner's manual are also included.

WARNING:

If any parts are missing, do not operate your router until the missing parts are replaced. Failure to do so could result in possible serious personal injury.

FEATURES

SWITCH

To turn your router **ON**, depress the switch trigger. Release switch trigger to turn your router **OFF**.

LOCK-ON BUTTON

The switch of your router is equipped with a **lock-on** feature which is convenient when operating for extended periods of time. To lock on, depress the trigger, push in the lock button located on the side of the handle, then while holding the lock button pushed in, release the trigger. To release the lock, depress the trigger and release it.

WARNING:

Before connecting your router to power supply source, always check to be sure it is not in lock-on position (depress and release switch trigger). Failure to do so could result in accidental starting of your router resulting in possible serious injury. Also, do not lock the trigger on jobs where your router may need to be stopped suddenly.

CHIP SHIELD

A clear plastic chip shield is installed on the front of your router for protection against flying dust and chips. The shield is designed to fit the opening of the router base. If necessary to remove chip shield, squeeze the tabs on each end and pull outward. To replace, squeeze the tabs at each end, fit into opening, then release. **NOTE:** Model No. 315.175060 has a chip shield on the front and rear opening of the router base. **For your protection, do not use router without chip shield(s) properly in place.** If desired, the horsepower label can be removed from chip shield by simply peeling off.

WRENCH STORAGE AREA

Your router has a wrench storage area located on the top end cap portion of the motor housing. When installing or removing cutters, remove the wrench from its storage area. Proper storage of wrench when not in use will help reduce the possibility of losing wrench.

VARIABLE SPEED SWITCH WITH ELECTRONIC SPEED CONTROL

(MODEL NOS. 315.175050 AND 315.175060 ONLY)

See Figures 1b and 1c.

Your router has advanced electronic features, designed to assist you in getting the maximum use from your router. By

making proper speed selections, your router can be adjusted to specific routing needs. This eliminates much of the guess work previously needed to perform a given job. Both the experienced and inexperienced router users benefit, obtaining professional like results with fewer job errors.

The variable speed control allows the router speed to be adjusted from 15,000 to 25,000 rpm. The variable speed control selector is conveniently located outside the right handle near the operator's thumb or hand.

Speed can be set according to the approximate cutter diameter you will be using and to the hardness of the material being cut. The best cuts are made when the cutter is fed through material at the proper rate of feed.

DUST BAG ASSEMBLY (MODEL NO. 315.175060 ONLY)

See Figure 1c.

The dust bag located on the side of your router provides a dust collection system for your router. For more efficient operation, empty dust bag when half full.

Do not connect router to power supply before installing dust bag or connecting it to a dust collection system.

WARNING:

To prevent the possibility of sawdust or foreign objects being thrown into your face and eyes, never attempt to use your router without dust bag properly installed. Sawdust or foreign objects being thrown into your face or eyes could result in possible serious injury.

TO INSTALL DUST BAG:

The dust bag should be installed by slipping it with a twisting motion over the blower exhaust. The bag should be installed with the zipper down when router is in upright position.

TO EMPTY DUST BAG:

Remove dust bag from router, open zipper and shake out dust. Occasionally turn the dust bag inside out and brush the accumulation of dust from the inside of the bag. This will allow the air to flow through the bag better.

FEATURES

KNOW YOUR ROUTER

Before attempting to use your router, familiarize yourself with all operating features and safety requirements. See Figure 1.

WARNING:

Do not allow familiarity with your router to make you careless. Remember that a careless fraction of a second is sufficient to inflict severe injury.

WARNING:

Always wear safety goggles or safety glasses with side shields when operating your router. Failure to do so could result in dust, shavings, loose particles or foreign objects being thrown into your eyes, causing possible serious injury.

MODEL NO. 315.175040

UPSIDE DOWN VIEW OF ROUTER

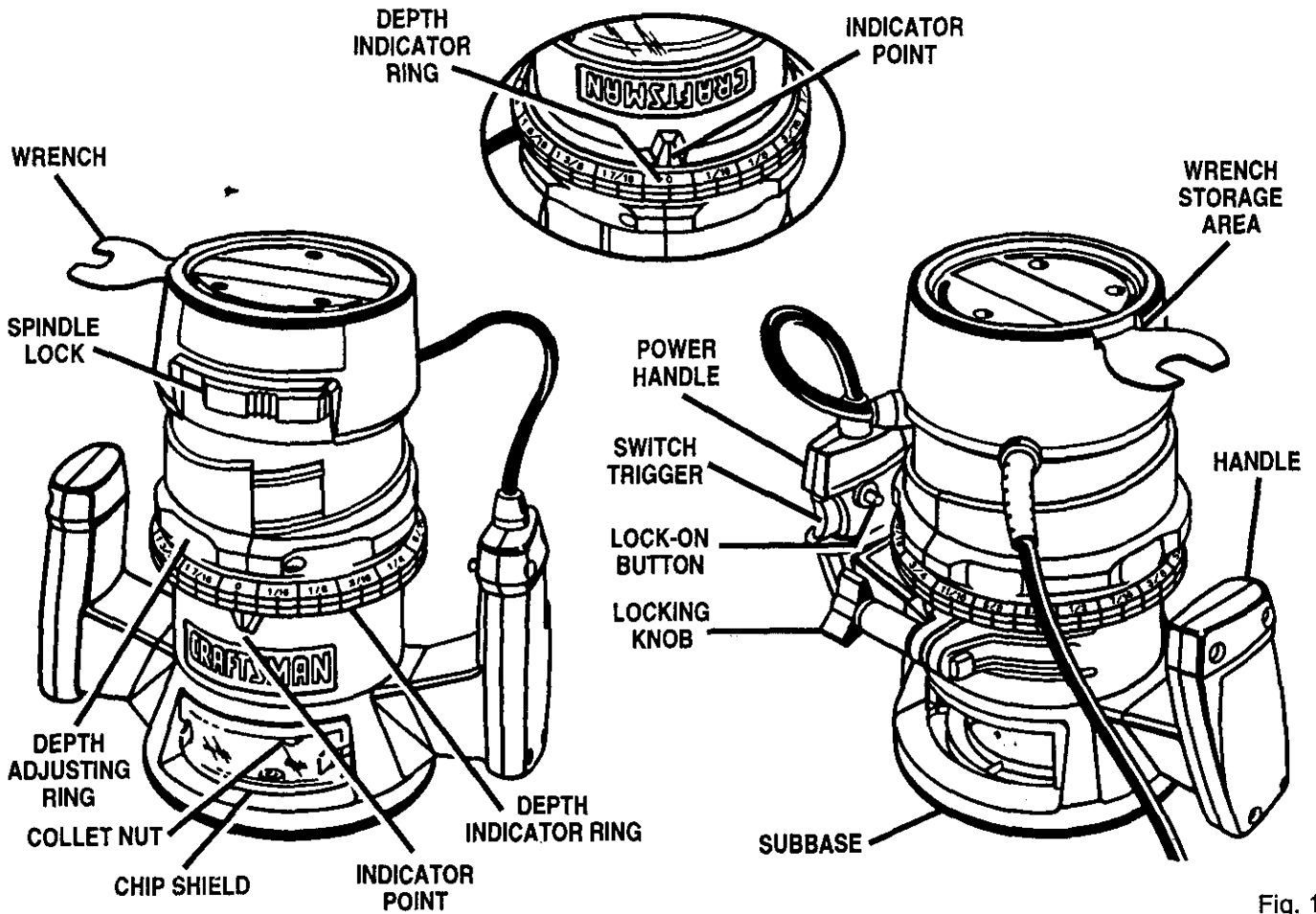

Fig. 1a

OPERATION

WARNING:

Your router should never be connected to power supply when you are assembling parts, making adjustments, installing or removing cutters, or when not in use. Disconnecting your router will prevent accidental starting that could cause serious injury.

INSTALLING/REMOVING CUTTERS

See Figures 2 and 3.

■ UNPLUG YOUR ROUTER.

WARNING:

Failure to unplug your router could result in accidental starting causing serious injury.

If your router is Model No. 315.175060, before installing/removing cutters, you must remove one of the chip shields from router base.

- A spindle lock is located on the front of the motor housing. To activate lock, push spindle lock in and slide into lock position. See Figure 2.

WARNING:

To prevent damage to the spindle or spindle lock, always allow motor to come to a complete stop before engaging spindle lock.

- Place your router upside down on table, then turn collet nut with wrench until lock mechanism interlocks. See Figure 3.

NOTE: Spindle lock is spring loaded and will snap into position when lock mechanism interlocks.

WARNING:

If you are changing a cutter immediately after use, be careful not to touch the cutter or collet with your hands or fingers. They will get burned because of the heat buildup from cutting. Always use the wrench provided.

- Remove cutters by turning collet nut counterclockwise enough to allow cutter to slip easily from collet. See Figure 3. The collet is machined to precision tolerances to fit cutters with 1/4 in. diameter shank size.
- With your router still upside down on table, insert shank of cutter into collet. The shank of your cutter should be close to but not touching bottom of collet.
- Tighten the collet nut securely by turning clockwise with the wrench provided. See Figure 3. Push spindle lock in and slide into unlock position. Otherwise, the

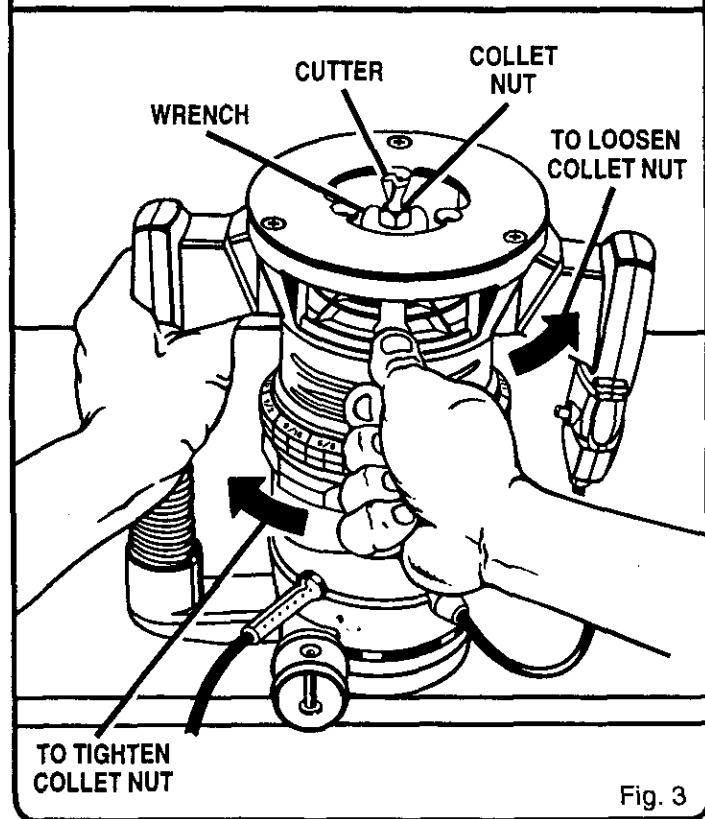
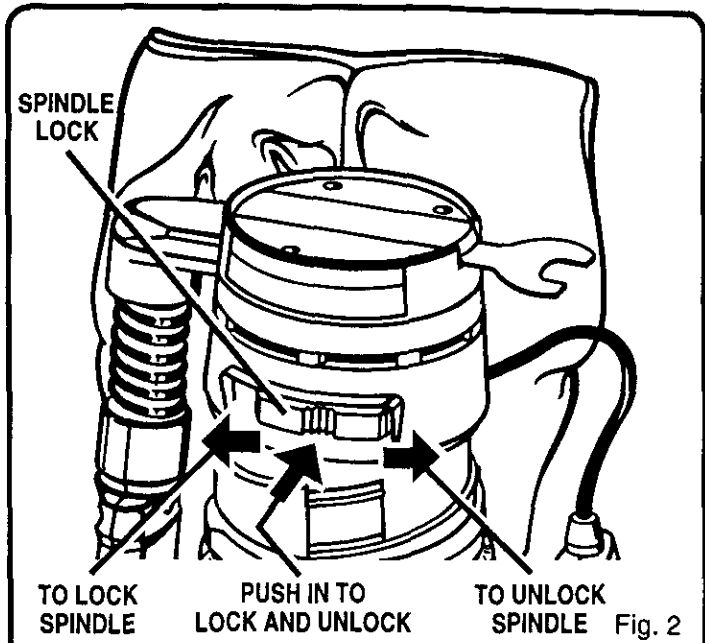

interlocking mechanism of the spindle lock will not let you turn your router on.

- Replace chip shield on Model No. 315.175060.

WARNING:

Do not use cutters with undersized shanks. Undersized shanks will not tighten properly and could be thrown from tool causing injury.

OPERATION

DEPTH OF CUT ADJUSTMENTS

See Figures 4, 5, and 6.

We recommend that cuts be made at a depth not exceeding 1/8 in. and that several passes be made to reach depths of cut greater than 1/8 in.

■ UNPLUG YOUR ROUTER.

WARNING:

Failure to unplug your router could result in accidental starting causing serious injury.

- Place your router on a flat surface, loosen locking knob, and turn depth adjusting ring until cutter is inside subbase. See Figure 4.
- Turn depth adjusting ring until tip of cutter touches flat surface. Turn the depth indicator ring until the zero lines up with the indicator point on the base. **NOTE:** The depth indicator ring is also a zero reset indicator when setting cutter at zero depth of cut, then it becomes the depth adjusting ring. See Figure 5.
- Position your router so that the cutter can extend below the subbase for desired depth setting. See Figure 6.
- Turn the depth adjusting ring to obtain the desired depth of cut. The distance the cutter moves can be read on the depth indicator ring. Each mark on the depth indicator ring indicates 1/16 inch change in depth setting. Indicator point is located on the base.
- Tighten locking knob securely before operating router.

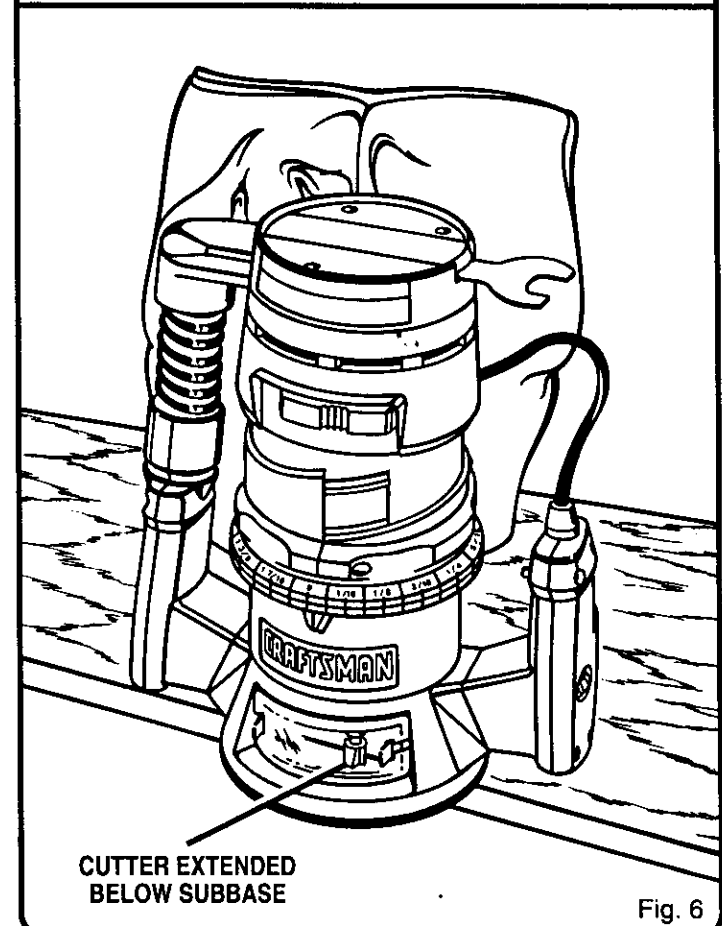
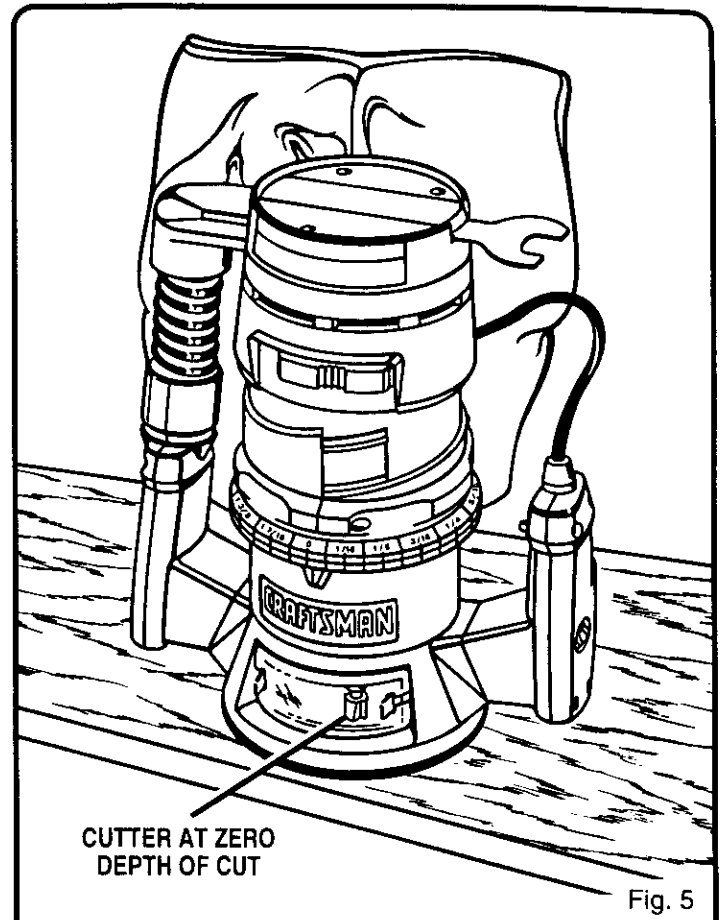
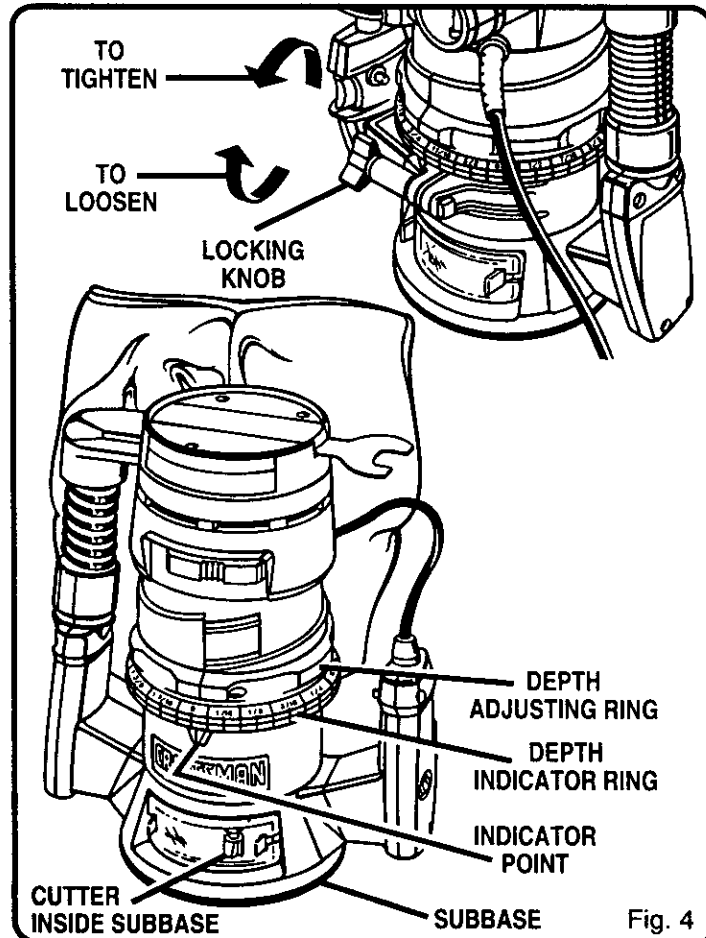

OPERATION

DEPTH OF CUT ADJUSTMENTS WHEN ROUTER IS MOUNTED TO A ROUTER TABLE

See Figure 7.

The depth of cut is readable from both sides of the depth indicator ring. The bottom ring is convenient when using your router mounted upside down to a router table. The indicator point on the base can also be used when using your router mounted to a router table.

Set the cutter at zero depth of cut, rotate depth indicator ring to desired depth of cut on the scale, then tighten locking knob securely.

VARIABLE SPEED

(MODEL NOS. 315.175050 AND 315.175060)

See Figure 8.

If your router is either one of these two models, it has a variable speed control selector designed to allow operator control of speed and torque limits. To increase the speed and torque of your router, turn the variable speed control selector to a higher setting. Turn to a lower setting to decrease speed and torque.

NOTE: If you do not want to use the variable speed control selector, turn to the highest possible setting and the feature will not be active.

PRACTICE BEFORE ACTUAL USE

If your router is Model No. 315.175050 or 315.175060, we suggest that you practice with the variable speed feature of your router before installing a cutter and making cuts in wood. **Check the following before connecting your router to power supply.**

- Make sure power supply is 120 volts, 60 Hz, AC only.
- Make sure the spindle lock is in the unlocked position.
- Make sure the trigger is not in the lock-on position.
- Make sure there is not a cutter in the collet.
- Make sure the collet does not extend below the subbase.
- Choose the desired speed from the speed selection chart. See Figure 8.
- Turn the variable speed control selector to the desired setting.
- Plug your router into power supply source.
- Grasp your router firmly with both hands and turn on.

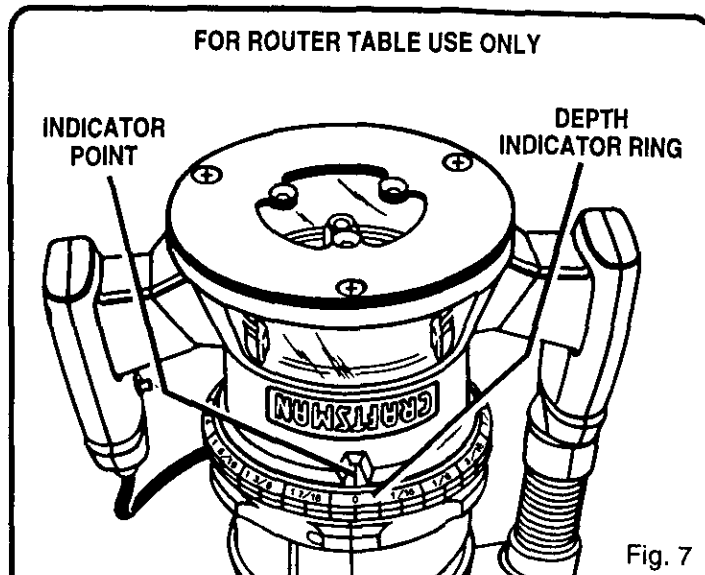

MODEL NOS. 315.175050 AND 315.175060

MATL	CUTTER SIZE			
	1/4	3/8	1/2	3/4
SOFT	8	7	3-4	1-2
MED.	6	6-7	2	1
HARD	6	3-4	1	1
VERY HD.	7	6-7	5	4

SPEED SELECTION CHART

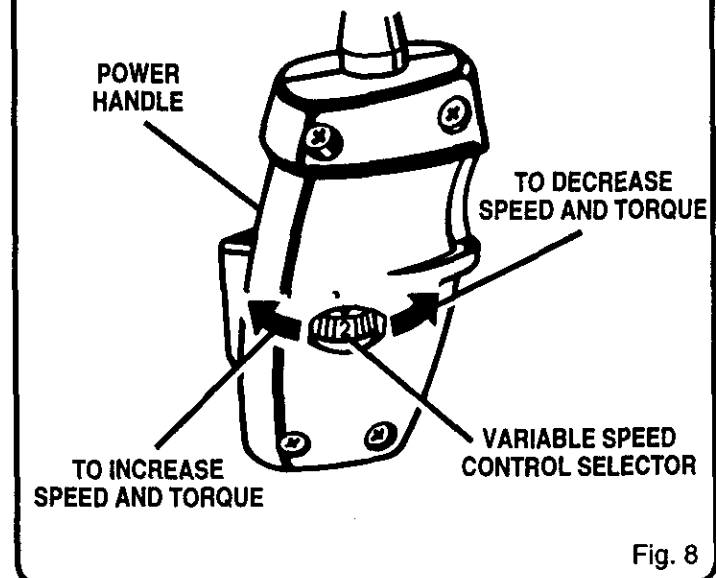

OPERATION

ROUTING

See Figure 9.

For ease of operation and maintaining proper control, your router has two handles, one on each side of the router base. When using your router hold it firmly with both hands as shown in figure 9. Turn router on and let motor build to its full speed, then gradually feed cutter into workpiece. Remain alert and watch what you are doing. **DO NOT** operate router when fatigued.

FREEHAND ROUTING

See Figure 10.

When used freehand, your router becomes a flexible and versatile tool. This flexibility makes it possible to easily rout signs, relief sculptures, etc.

There are two basic techniques for freehand routing:

- Routing letters, grooves, and patterns into wood. See Figure 10.
- Routing out the background, leaving the letters or pattern raised above the surface.

When freehand routing, we suggest the following:

- Draw or layout the pattern on workpiece.
- Choose the appropriate cutter.
NOTE: A core box or V-groove bit is often used for routing letters and engraving objects. Straight bits and ball mills are often used to make relief carvings. Veining bits are used to carve small, intricate details.
- Rout the pattern in two or more passes. Make the first pass at 25% of the desired depth of cut. This will provide better control as well as being a guide for the next pass.
- **DO NOT** rout deeper than 1/8 in. per pass or cut.

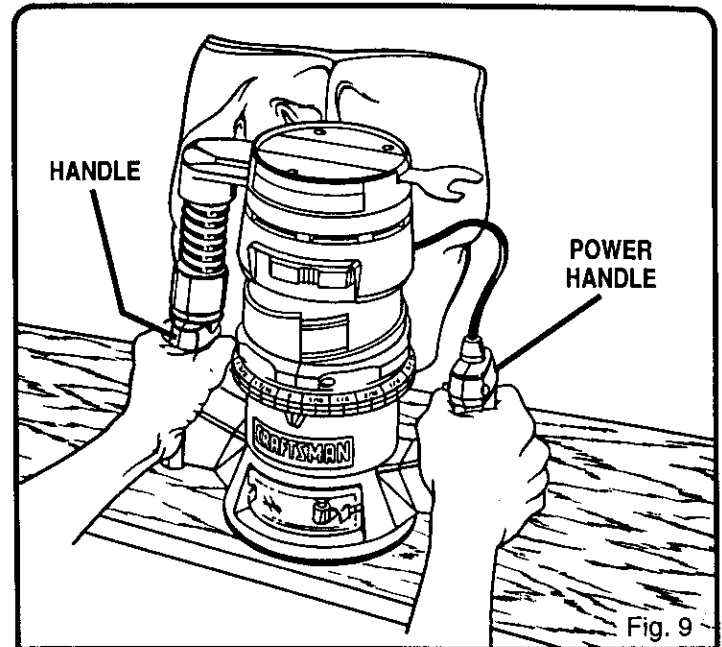
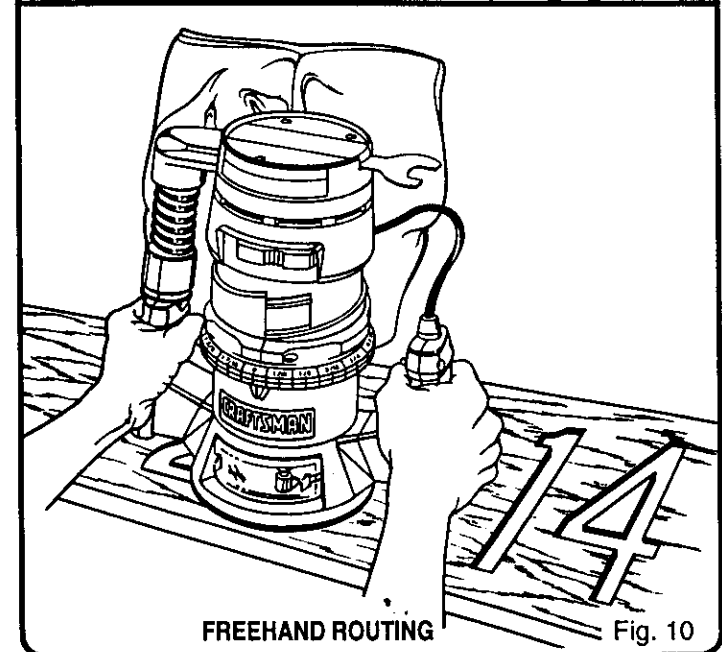

Fig. 9



FREEHAND ROUTING

Fig. 10

OPERATION

PROPER FEEDING

The right feed is neither too fast nor too slow. It is the rate at which the bit is being advanced firmly and surely to produce a continuous spiral of uniform chips — without hogging into the wood to make large individual chips or, on the other hand, to create only sawdust. If you are making a small diameter, shallow groove in soft, dry wood, the proper feed may be about as fast as you can travel your router along your guide line. On the other hand, if the bit is a large one, the cut is deep or the wood is hard to cut, the proper feed may be a very slow one. Then, again, a cross-grain cut may require a slower pace than an identical with grain cut in the same workpiece.

There is no fixed rule. You will learn by experience. . . by listening to the router motor and by feeling the progress of each cut. If at all possible, always test a cut on a scrap piece of the workpiece wood, beforehand.

SPEED SELECTION

(MODEL NOS. 315.175050 AND 315.175060 ONLY)

In general, if the material being cut is hard, the cutter size is large, or the depth of cut is deep (maximum 1/8 in.), then your router should be run at slower speeds. When these situations exist, turn the variable speed control selector until the desired speed is reached.

NOTE: Carbide cutters cut at higher speeds than steel cutters and should be used when cutting very hard materials.

RATE OF FEED

IMPORTANT: The whole "secret" of professional routing and edge shaping lies in making a careful set-up for the cut to be made and in selecting the proper rate of feed.

FORCE FEEDING

Clean, smooth routing and edge shaping can be done only when the bit is revolving at a relatively high speed and is taking very small bites to produce tiny, cleanly severed chips. If your router is forced to move forward too fast, the RPM of the bit becomes slower than normal in relation to its forward movement. As a result, the bit must take bigger bites as it revolves. "Bigger bites" mean bigger chips, and a rougher finish. Bigger chips also require more power, which could result in the router motor becoming overloaded.

Under extreme force-feeding conditions the relative RPM of the bit can become so slow — and the bites it has to take so large — that chips will be partially knocked off (rather than fully cut off), with resulting splintering and gouging of the workpiece. See Figure 11.

Your Craftsman Router is an extremely high-speed tool, and will make clean, smooth cuts if allowed to run freely without the overload of a forced (too fast) feed. Three things that cause "force feeding" are bit size, depth-of-cut, and workpiece characteristics. The larger the bit or the deeper the cut, the more slowly the router should be moved forward. If the wood is very hard, knotty, gummy or damp, the operation must be slowed still more.

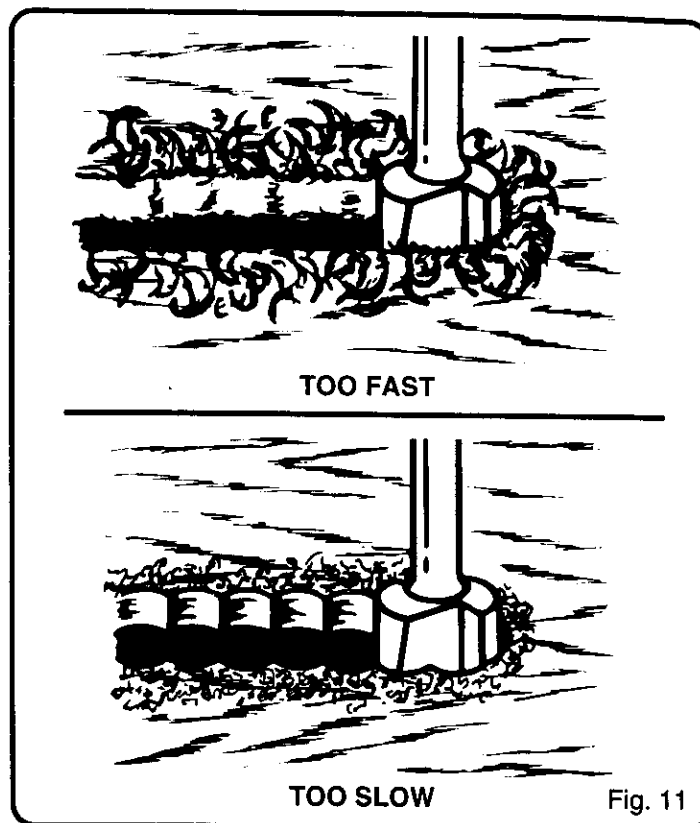

Fig. 11

You can always detect "force feeding" by the sound of the motor. Its high-pitched whine will sound lower and stronger as it loses speed. Also, the strain of holding the tool will be noticeably increased.

TOO SLOW FEEDING

It is also possible to spoil a cut by moving the router forward too slowly. When it is advanced into the work too slowly, a revolving bit does not dig into new wood fast enough to take a bite; instead, it simply scrapes away sawdust-like particles. Scraping produces heat, which can glaze, burn, or mar the cut—in extreme cases, can even overheat the bit so as to destroy its hardness.

In addition, it is more difficult to control a router when the bit is scraping instead of cutting. With practically no load on the motor the bit will be revolving at close to top RPM, and will have a much greater than normal tendency to bounce off the sides of the cut (especially, if the wood has a pronounced grain with hard and soft areas). As a result, the cut produced may have rippled, instead of straight sides. See Figure 11.

"Too-slow feeding" can also cause your router to take off in a wrong direction from the intended line of cut. **Always grasp and hold your router firmly with both hands when routing.**

You can detect "too-slow feeding" by the runaway too-highly pitched sound of the motor; or by feeling the "wobble" of the bit in the cut.

OPERATION

DEPTH OF CUT

As previously mentioned, the depth of cut is important because it affects the rate of feed which, in turn, affects the quality of a cut (and, also, the possibility of damage to your router motor and bit). A deep cut requires a slower feed than a shallow one, and a too deep cut will cause you to slow the feed so much that the bit is no longer cutting, it is scraping, instead.

Making a deep cut is never advisable. The smaller bits — especially those only 1/16 inch in diameter — are easily broken off when subjected to too much side thrust. A large enough bit may not be broken off, but if the cut is too deep a rough cut will result — and it may be very difficult to guide and control the bit as desired. For these reasons, we recommend that you do not exceed 1/8 inch depth of cut in a single pass, regardless of the bit size or the softness or condition of the workpiece. See Figure 12.

To make deeper cuts it is therefore necessary to make as many successive passes as required, lowering the bit 1/8 inch for each new pass. In order to save time, do all the cutting necessary at one depth setting, before lowering the bit for the next pass. This will also assure a uniform depth when the final pass is completed. See Figure 13.

DIRECTION OF FEED AND THRUST

The router motor and bit revolve in a clockwise direction. This gives the tool a slight tendency to twist (in your hands) in a counterclockwise direction, especially when the motor is starting up.

Because of the extremely high speed of bit rotation during a "proper feeding" operation, there is very little kickback to contend with under normal conditions. However, should the bit strike a knot, hard grain, foreign object, etc. that would affect the normal progress of the cutting action, there will be a slight kickback — sufficient to spoil the trueness of your cut if you are not prepared. Such a kickback is always in the direction opposite to the direction of bit rotation.

To guard against such a kickback, plan your set-up and direction of feed so that you will always be thrusting the tool — to hold it against whatever you are using to guide the cut — in the same direction that the leading edge of the bit is moving. In short, the thrust should be in a direction that keeps the sharp edges of the bit continuously biting straight into new (uncut) wood.

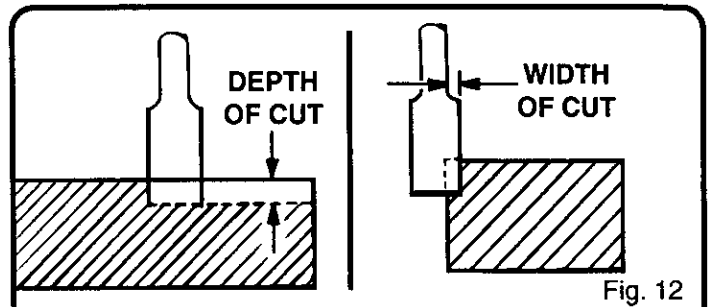

Fig. 12

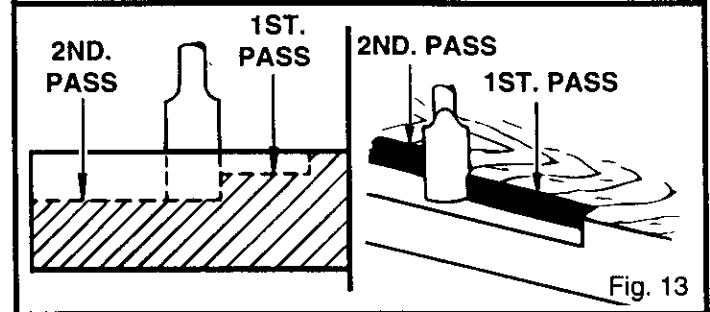

Fig. 13

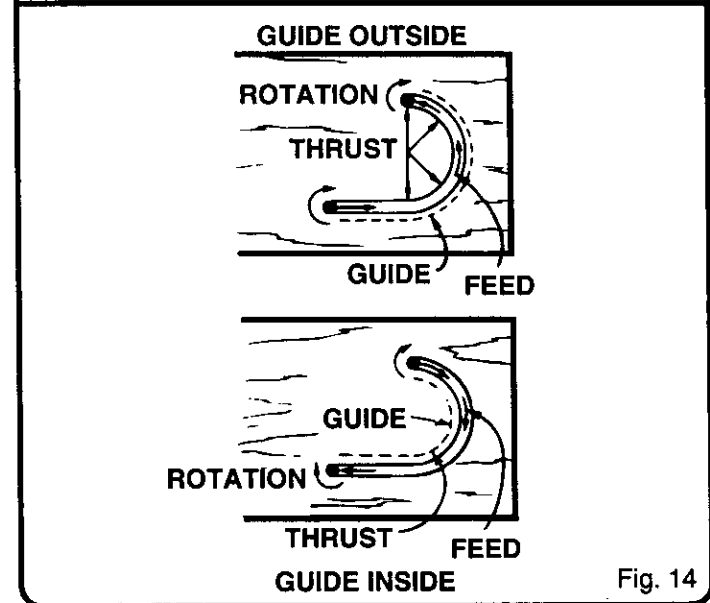

Fig. 14

ROUTING

Whenever you are routing a groove, your travel should be in a direction that places whatever guide you are using at the right-hand side. In short, when the guide is positioned as shown in the first part of Figure 14, tool travel should be left to right and counterclockwise around curves. When the guide is positioned as shown in the second part of Figure 14 tool travel should be right to left and clockwise around curves. If there is a choice, the first set-up is generally the easiest to use. In either case, the sideways thrust you use is against the guide.

OPERATION

STARTING AND ENDING A CUT

INTERNAL ROUTING

Tilt router and place on workpiece, letting edge of subbase contact workpiece first. Be careful not to let router bit contact workpiece. Turn router on and let motor build to its full speed. Gradually feed cutter into workpiece until subbase is level with workpiece.

WARNING:

Keep a firm grip on router with both hands at all times. Failure to do so could result in loss of control leading to possible serious injury.

Upon completion of cut, turn motor off and let it come to a complete stop before removing router from work surface.

WARNING:

Never pull router out of work and place upside down on work surface before the cutter stops.

EDGING WITH PILOT BITS

The arbor-type bits with pilots are excellent for quick, easy, edge shaping of any workpiece edge that is either straight or curved at a curvature as great or greater than the radius of the bit to be used. The pilot prevents the bit from making too deep a cut; and holding the pilot firmly in contact with the workpiece edge throughout prevents the cut from becoming too shallow.

Whenever the workpiece thickness together with the desired depth of cut (as adjusted by router depth setting) are such that only the top part of the edge is to be shaped (leaving at least a 1/16 inch thick uncut portion at bottom), the pilot can ride against the uncut portion, which will serve to guide it. *See Figure 15.* However, if the workpiece is too thin or the bit set too low so that there will be no uncut edge to ride the pilot against, an extra board to act as a guide must be placed under the workpiece. This "guide" board must have exactly the same contour — straight or curved — as the workpiece edge. If it is positioned so that its edge is flush with the workpiece edge, the bit will make a full cut (in as far as the bit radius). On the other hand, if the guide is positioned as shown in Figure 15 (out from the workpiece edge), the bit will make less than a full cut — which will alter the shape of the finished edge.

NOTE: Any of the piloted bits can be used without a pilot for edge shaping with guides, as preceding. The size (diameter) of the pilot that is used determines the maximum cut width that can be made with the pilot against the workpiece edge (the small pilot exposes all of the bit; the large one reduces this amount by 1/16 inch).

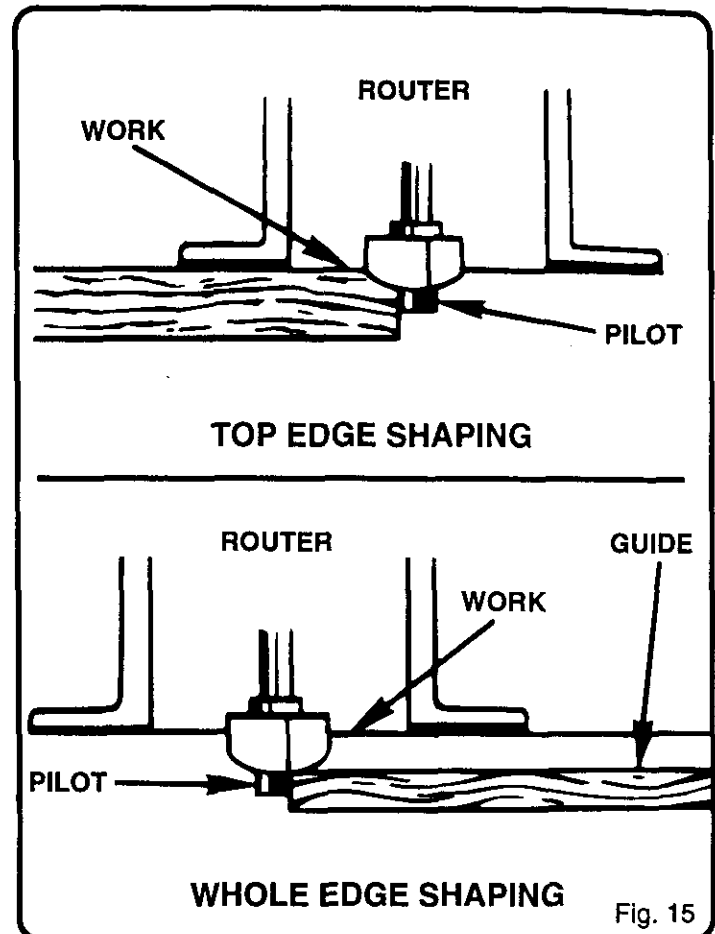

EDGE ROUTING

Place router on workpiece, making sure the router bit does not contact workpiece. Turn router on and let motor build to its full speed. Begin your cut, gradually feeding cutter into workpiece.

WARNING:

Keep a firm grip on router with both hands at all times. Failure to do so could result in loss of control leading to possible serious injury.

Upon completion of cut, turn motor off and let it come to a complete stop before removing router from work surface.

WARNING:

Never pull router out of work and place upside down on work surface before the cutter stops.

OPERATION

ROUTING WITH GUIDE BUSHINGS

When using the Template Guide Bushings Item No. 9-25082 with your router, you must visually center the bit with the bushing before beginning your cut. Your router subbase may be adjusted by loosening the screws holding the subbase to your router. Be sure clamping lever is locked before centering bit in bushing. After centering bit with bushing, tighten screws firmly.

WARNING:

Failure to center bit with bushing or to firmly tighten screws after centering could cause bit to come in contact with bushing resulting in serious injury.

ROUTER TABLES

The use of Craftsman routers on router tables offered by other manufacturers has not been investigated for compliance with applicable safety standards.

WARNING:

Do not use with router tables that fail to conform to safe wood working practices and offer proper guarding for the cutter. Failure to comply can result in an accident causing possible serious injury.

MAINTENANCE

SWITCH REPLACEMENT (MODEL NO. 315.175040)

See Figures 16 and 17.

■ UNPLUG YOUR ROUTER.

WARNING:

Failure to unplug your router could result in accidental starting causing serious injury.

- Remove screws (A) and handle cover (B). See Figure 16.
- Note the location of the molded bend relief (C) on the power handle cord. Also note all wiring in the handle and how each lead is connected to the switch. Connections and wiring position must be identical when installing new switch. See Figure 16.
- Remove leads from switch (D) by inserting a 1/32 in. diameter nail or pin into switch lead receptacle and pulling on lead as shown in figure 17. Remove nail or pin with a twisting, pulling motion.
- Make lead connections to new switch. Push each lead as far as possible into proper switch receptacle. Pull on leads to check lead connections with lead receptacles.
- Locate switch in handle and place leads so they won't be pinched or contact screws when handle cover is replaced.
- Make sure molded bend relief (C) is correctly positioned in switch handle, then replace handle cover and screws.
- Tighten all screws securely.

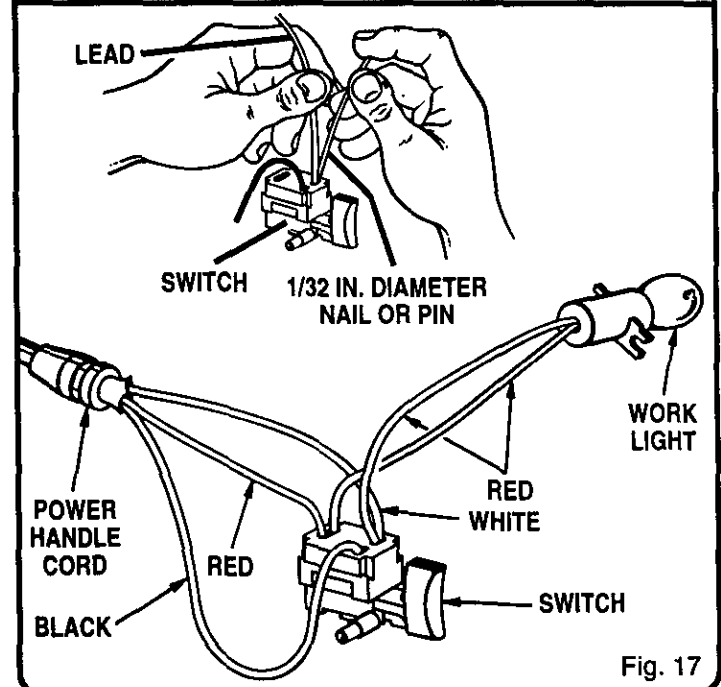
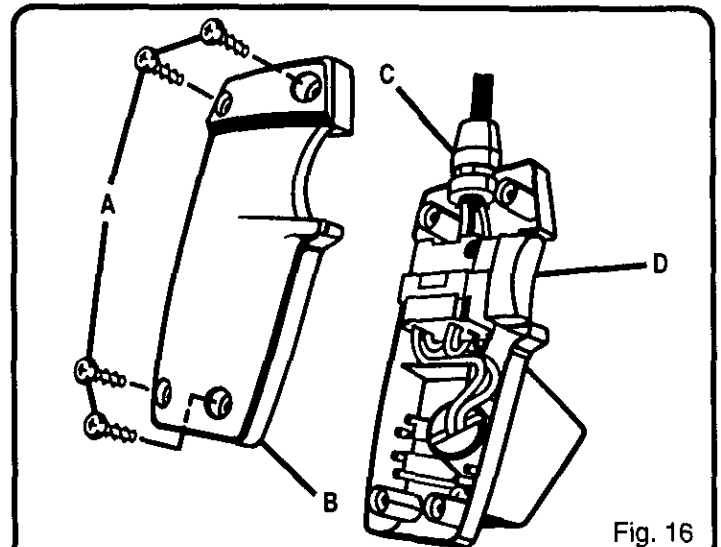

MAINTENANCE

SWITCH REPLACEMENT (CONTINUED) (MODEL NOS. 315.175050 AND 315.175060)

See Figures 18 and 19.

■ UNPLUG YOUR ROUTER.

⚠ WARNING:

Failure to unplug your router could result in accidental starting causing serious injury.

- Remove screws (A) and handle cover (B). See Figure 18.
- Note the location of the molded bend relief (C) on the power handle cord. Also note all wiring in the handle and how each lead is connected to the switch. Connections and wiring position must be identical when installing new switch. See Figure 18.
- Remove leads from switch (D) by inserting a 1/32 in. diameter nail or pin into switch lead receptacle and pulling on lead as shown in figure 19. Remove nail or pin with a twisting, pulling motion.
- Make lead connections to new switch. Push each lead as far as possible into proper switch receptacle. Pull on leads to check lead connections with lead receptacles.
- Locate switch in handle and place leads so they won't be pinched or contact screws when handle cover is replaced.
- Make sure molded bend relief (C) is correctly positioned in switch handle, then replace handle cover and screws.
- Tighten all screws securely.

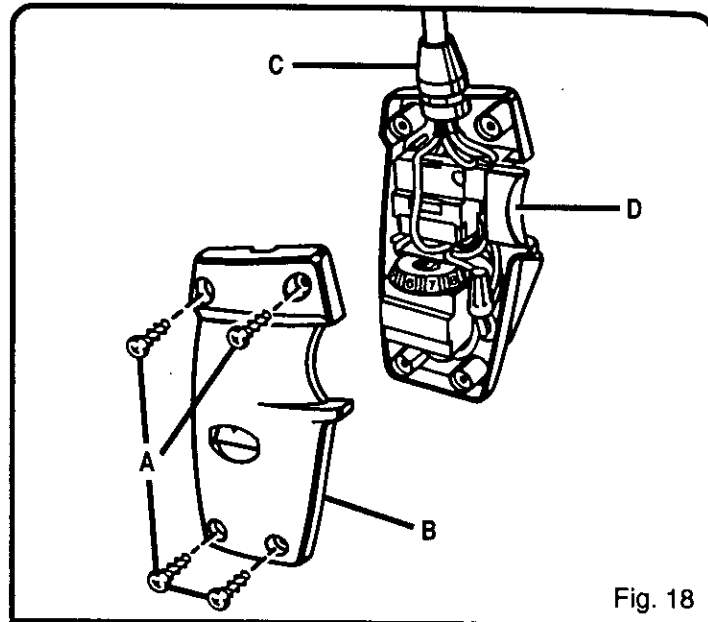

Fig. 18

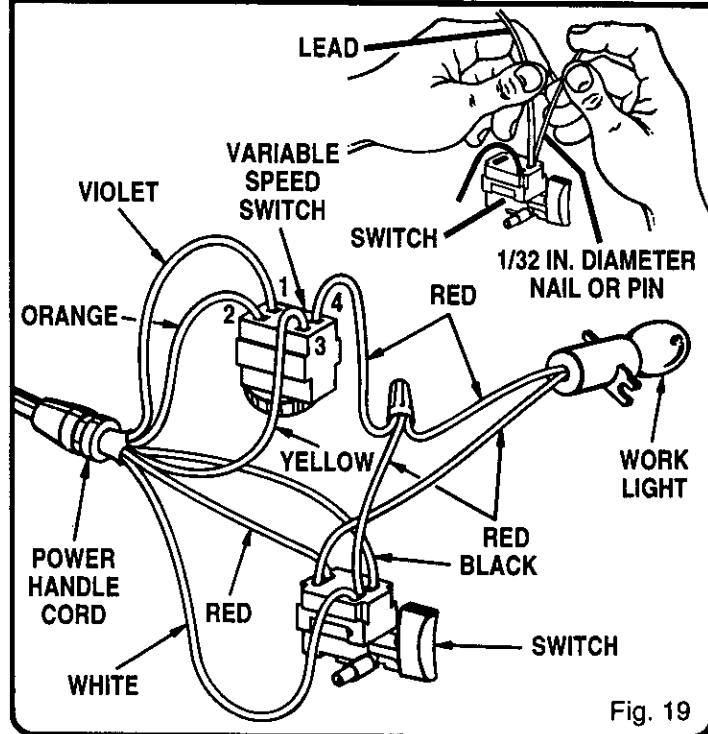

Fig. 19

MAINTENANCE

LIGHT BULB REPLACEMENT

See Figure 20.

■ UNPLUG YOUR ROUTER.

WARNING:

Failure to unplug your router could result in accidental starting causing serious injury.

- Remove cutter from router.
- Adjust router to maximum height.
- Remove screws (A) and subbase (B). See Figure 20.
- Remove screw (C) and work light lens (D).
- With bulb (E) pointing toward you, push bulb in and turn to the left to remove from bulb socket.
NOTE: Light bulb removal and installation is similar to removing and installing a standard automotive bulb.
- Install new bulb by reversing the above procedure.
- Reassemble all parts and tighten screws securely.

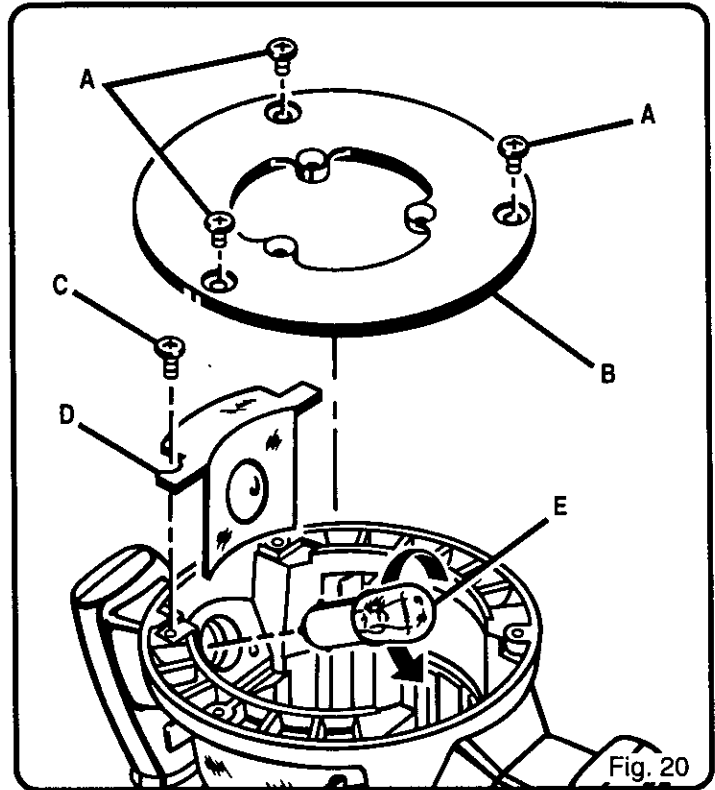

PROPER CARE OF CUTTERS

Get faster and more accurate cutting results by keeping cutters clean and sharp. Remove all accumulated pitch and gum from cutters after each use.

A cutter sharpening kit (Item No. 9-66501) is available from Sears Retail Stores.

When sharpening cutters, sharpen only the inside of the cutting edge. Never grind the outside diameter. Be sure when sharpening the end of a cutter to grind the clearance angle the same as originally ground.

HELPFUL HINTS

- ✓ Always clamp workpiece securely before routing.
- ✓ A safe operator is one who thinks ahead.
- ✓ Always wear eye protection when routing.
- ✓ Make set-up adjustments carefully. Then double check. Measure twice and cut once.
- ✓ Keep cutters clean and properly sharpened.
- ✓ Don't let familiarity make you careless.
- ✓ Study all safety rules and do the job safely.
- ✓ **NEVER** place your hands in jeopardy.
- ✓ Make certain clamps can't loosen while in use.
- ✓ Test difficult set-ups on scrap — Don't waste lumber.
- ✓ Plan each operation before you begin.
- ✓ Clean your router frequently. This will provide smoother operation of depth adjusting ring and locking knob areas. Shake router or blow with an air jet to remove sawdust build-up.
- ✓ **THINK SAFETY BY THINKING AHEAD.**

PROPER CARE OF COLLET

From time to time, it also becomes necessary to clean your collet and collet nut. To do so, simply remove collet nut from collet and clean the dust and chips that have collected. Then return collet nut to its original position.

LUBRICATION

All of the bearings in this tool are lubricated with a sufficient amount of high grade lubricant for the life of the unit under normal operating conditions. Therefore, no further lubrication is required.

MAINTENANCE

WARNING:

When servicing use only identical Craftsman replacement parts. Use of any other parts may create a hazard or cause product damage.

GENERAL

Only the parts shown on parts list, pages 23, 25 and 27 are intended to be repaired or replaced by the customer. All other parts represent an important part of the double insulation system and should be serviced only by a qualified Sears service technician.

Avoid using solvents when cleaning plastic parts. Most plastics are susceptible to damage from various types of commercial solvents and may be damaged by their use. Use clean cloths to remove dirt, carbon dust, etc.

WARNING:

Do not at any time let brake fluids, gasoline, petroleum-based products, penetrating oils, etc. come in contact with plastic parts. They contain chemicals that can damage, weaken, or destroy plastic.

When electric tools are used on fiberglass boats, sports cars, wallboard, spackling compounds, or plaster, it has been found that they are subject to accelerated wear and possible premature failure, as the fiberglass chips and grindings are highly abrasive to bearings, brushes, commutators, etc. Consequently it is not recommended that this tool be used for extended work on any fiberglass material, wallboard, spackling compounds, or plaster. During any use on these materials, it is extremely important that the tool is cleaned frequently by blowing with an air jet.

WARNING:

Always wear safety goggles, or safety glasses with side shields during power tool operation or when blowing dust. If operation is dusty, also wear a dust mask.

EXTENSION CORDS

The use of any extension cord will cause some loss of power. To keep the loss to a minimum and to prevent tool overheating, use an extension cord that is heavy enough to carry the current the tool will draw.

A wire gage size (A.W.G.) of at least 14 is recommended for an extension cord 100 feet or less in length. When working outdoors, use an extension cord that is suitable for outdoor use. The cord's jacket will be marked **WA**.

CAUTION:

Keep extension cords away from any routing area and position the cord so that it will not get caught on lumber, tools, etc., during routing operation.

WARNING:













Check extension cords before each use. If damaged replace immediately. Never use tool with a damaged cord since touching the damaged area could cause electrical shock resulting in serious injury.

ACCESSORIES

THE FOLLOWING RECOMMENDED ACCESSORIES ARE CURRENTLY AVAILABLE AT SEARS RETAIL STORES.

Dovetail Template
 Box Joint Template
 Butt Hinge Template
 Multi-Purpose Router Guide

Router - A - Form Pantograph
 Sharpening Kit

COMBI-NATION PANEL CUTTER 	VEINING BIT 	CORE BOX BIT V-GROOVE CHAMFER 	STRAIGHT FACE BIT 	COMBINATION STRAIGHT, BEVEL CUTTER 	HINGE MORTISING BIT 	DOVETAIL CUTTER BITS 	RABBET BIT 	OGEE, ROMAN O 	COVE BIT, 45° CHAMFER BIT 	BEAD QUARTER-ROUND BITS 	ARBOR 2589  WITH 2 BALL BEARINGS (1/2 IN. & 5/8 IN.) *25895
--	--	---	--	---	--	---	--	--	--	--	--

*CARBIDE TIPPED BITS

*25895 FOR CARBIDE TIPPED EDGE FORMING BITS

2589 FOR HIGH SPEED STEEL EDGE FORMING BITS



WARNING: The use of attachments or accessories not listed above might be hazardous.

CRAFTSMAN ROUTER - MODEL NUMBER 315.175040

The model number will be found on a plate attached to the motor housing. Always mention the model number in all correspondence regarding your **ROUTER** or when ordering repair parts.

SEE BACK PAGE FOR PARTS ORDERING INSTRUCTIONS

PARTS LIST

Key No.	Part Number	Description	Quan.
1	973741-001	Data Plate	1
2	970692-001	Label	1
3	989985-003	Collet Nut (1/4 in.)	1
4	974722-000	Depth Adjusting Ring Assembly (Includes Key No. 24)	1
5	974131-001	Depth Indicator Ring	1
6	623166-006	* Square Head Bolt (#1/4-20 x 1-1/4 in.)	1
7	622832-014	Roll Pin	1
8	606066-004	* Screw (#10-32 x 3/4 in. Pan Hd.)	4
9	617966-030	* Screw (#8-10 x 5/8 in. Pan Hd.)	8
10	970697-000	Handle Assembly	1
11	973735-002	Base	1
12	606688-002	Chip Shield	1
13	998586-001	* Screw (#10-32 x 1/4 in. Pan Hd.)	3
14	612191-004	Subbase	1
15	989684-001	* Screw (#6-32 x 1/4 in. T.C. Pan Hd.)	1
16	975041-001	Work Light Lens	1
17	610930-002	Light Housing	1
18	970696-000	Power Handle Assembly	1
19	610951-001	Light Bulb	1
20	998895-001	Switch	1
21	623173-006	Wire Nut	1
22	999603-001	Knob	1
23	931744-059	Washer	3
24	970855-001	* Screw (#5-20 x 3/8 in. Hi-Lo Fil. Hd.)	2
25	989935-006	Wrench (9/16 in.)	1
	972000-248	Owner's Manual	

* Standard Hardware Item - May Be Purchased Locally



CRAFTSMAN ROUTER - MODEL NUMBER 315.175050

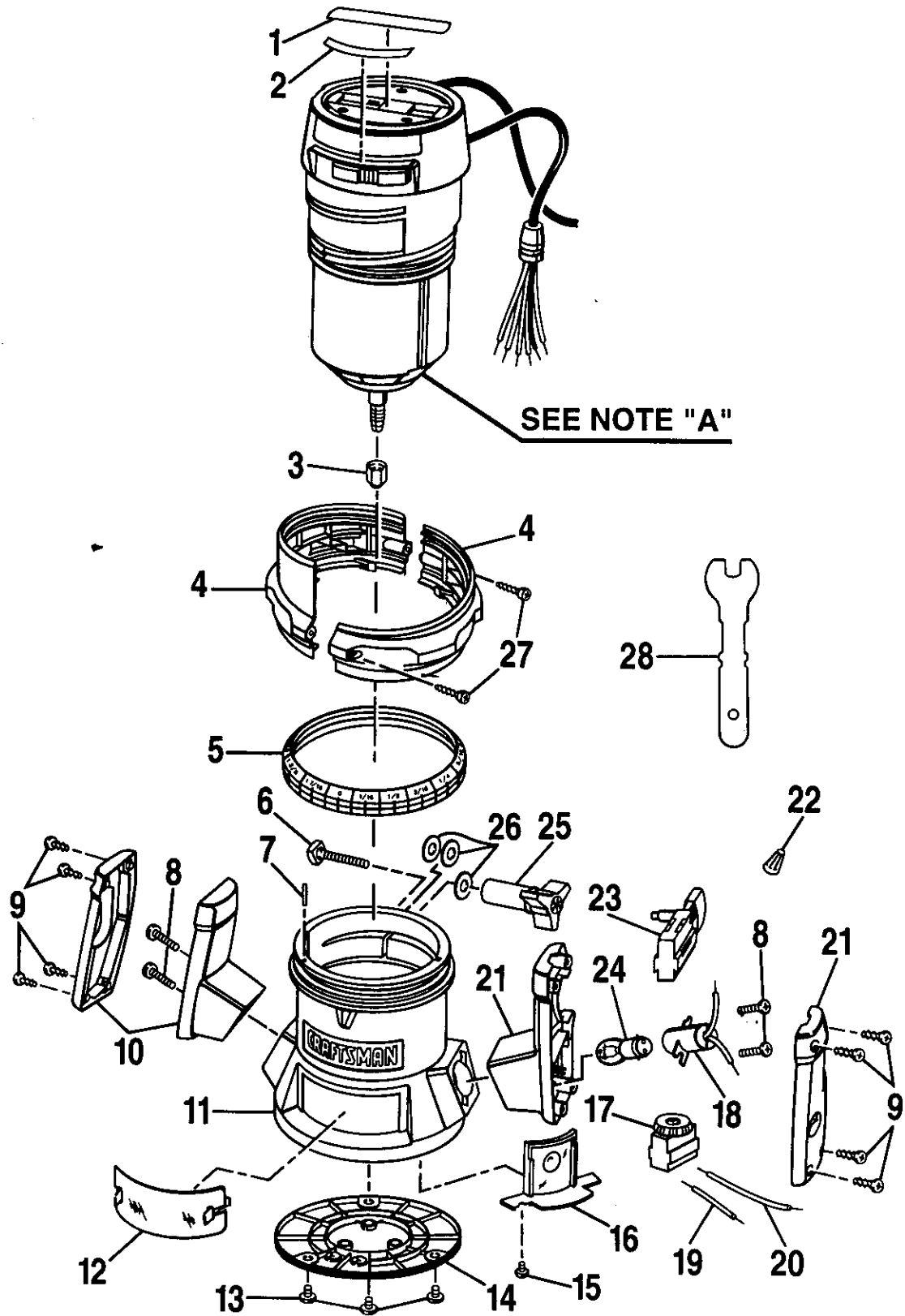

NOTE: "A" - The assembly shown represents an important part of the Double Insulated System. To avoid the possibility of alteration or damage to the System, service should be performed by your nearest Sears Repair Center. Contact your nearest Sears Retail Store for Service Center information.

CRAFTSMAN ROUTER - MODEL NUMBER 315.175050

The model number will be found on a plate attached to the motor housing. Always mention the model number in all correspondence regarding your **ROUTER** or when ordering repair parts.

SEE BACK PAGE FOR PARTS ORDERING INSTRUCTIONS

PARTS LIST

Key No.	Part Number	Description	Quan.
1	973742-001	Data Plate	1
2	970692-001	Label	1
3	989985-003	Collet Nut (1/4 in.)	1
4	974722-000	Depth Adjusting Ring Assembly (Includes Key No. 27)	1
5	974131-001	Depth Indicator Ring	1
6	623166-006	* Square Head Bolt (#1/4-20 x 1-1/4 in.)	1
7	622832-014	Roll Pin	1
8	606066-004	* Screw (#10-32 x 3/4 in. Pan Hd.)	4
9	617966-030	* Screw (#8-10 x 5/8 in. Pan Hd.)	8
10	970697-000	Handle Assembly	1
11	973735-002	Base	1
12	606688-002	Chip Shield	1
13	998586-001	* Screw (#10-32 x 1/4 in. Pan Hd.)	3
14	612191-004	Subbase	1
15	989684-001	* Screw (#6-32 x 1/4 in. T.C. Pan Hd.)	1
16	975041-001	Work Light Lens	1
17	990822-002	Variable Speed Control Selector	1
18	610930-002	Light Housing	1
19	970793-007	Red Lead	1
20	970793-008	Red Lead	1
21	970698-000	Power Handle Assembly	1
22	623173-006	Wire Nut	1
23	998895-002	Switch	1
24	610951-001	Light Bulb	1
25	999603-001	Knob	1
26	931744-059	Washer	3
27	970855-001	* Screw (#5-20 x 3/8 in. Hi-Lo Fil. Hd.)	2
28	989935-006	Wrench (9/16 in.)	1
	972000-248	Owner's Manual	

* Standard Hardware Item - May Be Purchased Locally



CRAFTSMAN ROUTER - MODEL NUMBER 315.175060

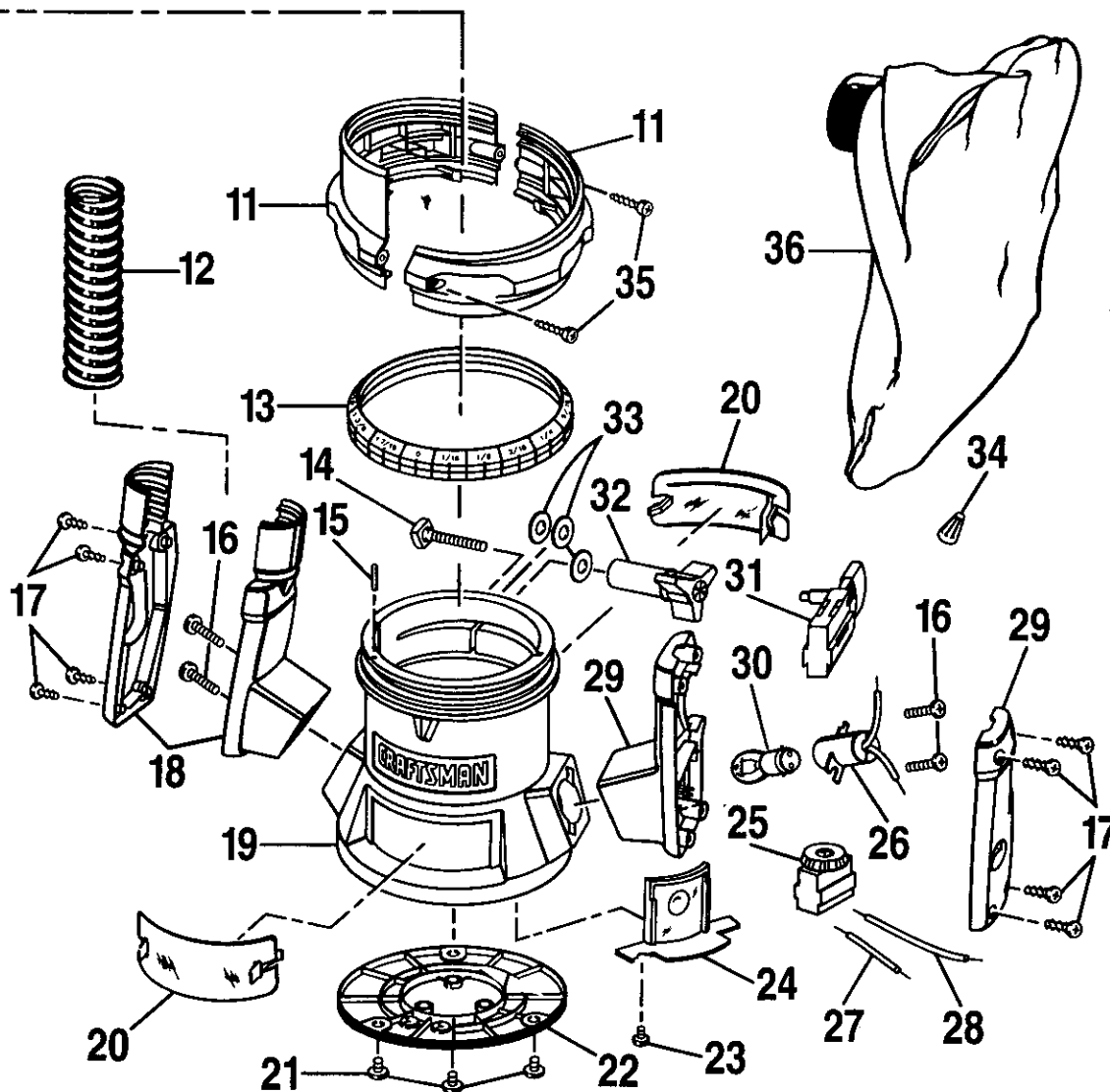
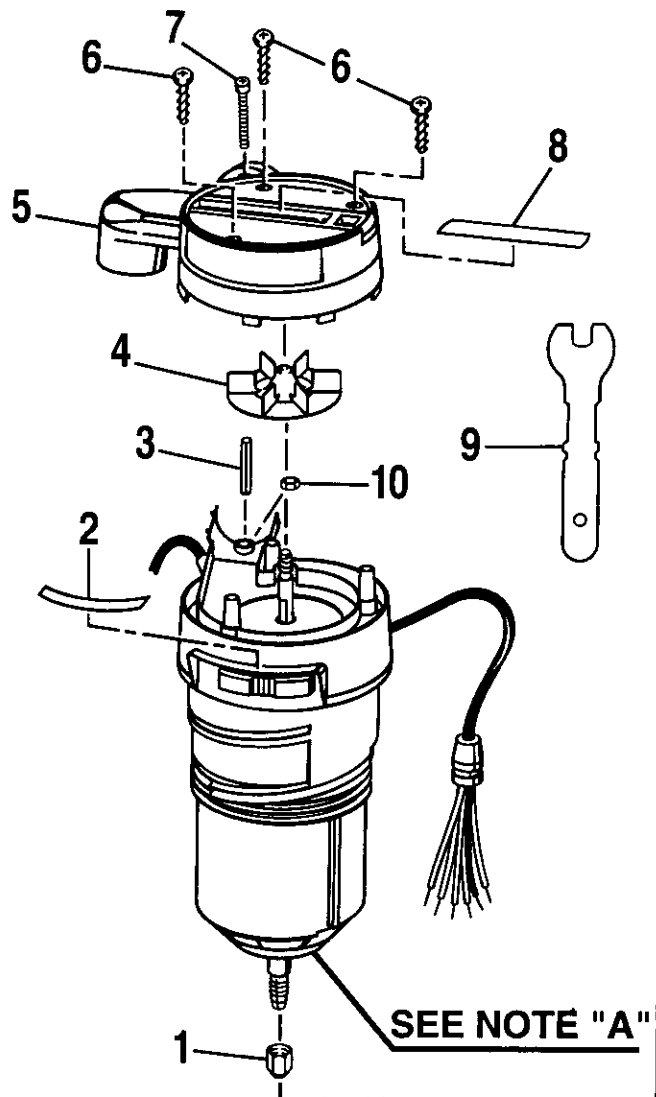

NOTE: "A"—The assembly shown represents an important part of the Double Insulated System. To avoid the possibility of alteration or damage to the system, service should be performed by your nearest Sears Repair Center. Contact your nearest Sears Retail Store for Service Center information.

CRAFTSMAN ROUTER - MODEL NUMBER 315.175060

The model number will be found on a plate attached to the motor housing. Always mention the model number in all correspondence regarding your ROUTER or when ordering repair parts.

SEE BACK PAGE FOR PARTS ORDERING INSTRUCTIONS

PARTS LIST

Key No.	Part Number	Description	Quan.	Key No.	Part Number	Description	Quan.
1	989985-003	Collet Nut (1/4 in.)	1	19	973735-204	Base	1
2	970692-002	Label	1	20	606688-002	Chip Shield	2
3	607433-003	Spacer	1	21	998586-001	* Screw (#10-32 x 1/4 in. Pan Hd.).....	3
4	610958-001	Blower	1	22	612191-004	Subbase	1
5	970517-004	End Cap	1	23	989684-001	* Screw (#6-32 x 1/4 in. T.C. Pan Hd.).....	1
6	617966-031	* Screw (#8-10 x 3/4 in. Pan Hd.).....	3	24	975041-001	Work Light Lens	1
7	622931-007	* Screw (#6-32 x 1-5/16 in. Fil. Hd.)	1	25	990822-002	Variable Speed Control Selector	1
8	973743-001	Data Plate	1	26	610930-002	Light Housing	1
9	989935-006	Wrench (9/16 in.)	1	27	970793-007	Red Lead	1
10	706404-004	* Hex Nut (#6-32) **STD541006	1	28	970793-008	Red Lead	1
11	974722-000	Depth Adjusting Ring Assembly (Includes Key No. 35)	1	29	970698-000	Power Handle Assembly	1
12	610966-002	Vacuum Hose	1	30	610951-001	Light Bulb	1
13	974131-001	Depth Indicator Ring	1	31	998895-002	Switch	1
14	623166-006	* Square Head Bolt (#1/4-20 x 1-1/4 in.)	1	32	999603-001	Knob	1
15	622832-014	Roll Pin	1	33	931744-059	Washer	3
16	606066-004	* Screw (#10-32 x 3/4 in. Pan Hd.).....	4	34	623173-006	Wire Nut	1
17	617966-030	* Screw (#8-10 x 5/8 in. Pan Hd.).....	8	35	970855-001	* Screw (#5-20 x 3/8 in. Hi-Lo Fil. Hd.).....	2
18	970699-000	Handle Assembly	1	36	971788-003	Dust Bag Assembly	1
					972000-248	Owner's Manual	

* Standard Hardware Item — May Be Purchased Locally ** Available From Div.98 — Source 980.00



Get it fixed, at your home or ours!

For repair of major brand appliances **in your own home...**
no matter who made it, no matter who sold it!

1-800-4-MY-HOMESM Anytime, day or night
(1-800-469-4663)

www.sears.com

To bring in products such as vacuums, lawn equipment and electronics
for repair, call for the location of your nearest **Sears Parts & Repair Center.**

1-800-488-1222 Anytime, day or night

www.sears.com

For the replacement parts, accessories and owner's manuals
that you need to do-it-yourself, call **Sears PartsDirectSM!**

1-800-366-PART 6 a.m. – 11 p.m. CST,
(1-800-366-7278) 7 days a week

www.sears.com/partsdirect

To purchase or inquire about a Sears Service Agreement:

1-800-827-6655

7 a.m. – 5 p.m. CST, Mon. – Sat.

Para pedir servicio de reparación a domicilio,
y para ordenar piezas con entrega a domicilio:

1-888-SU-HOGARSM
(1-888-784-6427)

Au Canada pour service en français:

1-877-LE-FOYERSM
(1-877-533-6937)

