

Kenmore

I N S T R U C T I O N S

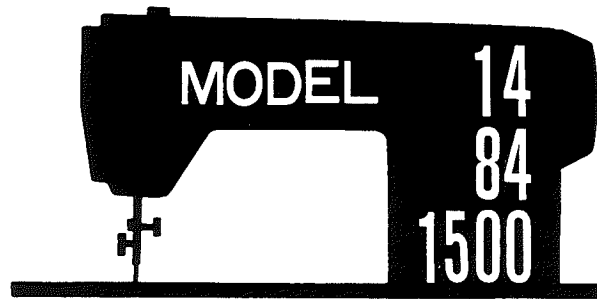

ZIG-ZAG SEWING MACHINE

P/N 59955

TABLE OF CONTENTS

Adjusting for Good Stitches	19	Needle Size	5
Adjusting Pressure of Presser Foot	10	Overcasting	23
Adjusting Tensions	12 - 13	Parts List	30 - 31
Applique	23	Picking up Bobbin Thread	10
Basting.....	11	Placement of Needle	5
Blind Stitching	22	Removing Bobbin Case from Shuttle	6
Buttonhole with Special Buttonhole Foot	20 - 21	Removing Lint	25
Changing the Attachment Foot	15	Replacement of Belt	25
Cleaning & Oiling	26 - 27	Reverse Stitching	11
Connecting Machine	4	Setting Stitch Length	11
Darning	18	Setting Stitch Width.....	16
Decorative Stitching	16 - 17	Sewing Light	4
Fastening a Seam.....	11	Sewing on Buttons	22
Feed Dog Control	15	Sewing on Lace	22
Identification - Head Parts	2 - 3	Sewing on Plastic Films	24
Inserting Bobbin into Bobbin Case	8	Synthetics	24
Inserting Disc	16	Threading Upper Machine	9
Inserting & Removing Material	14	Turning a Corner	15
Installing Machine Head	4	What to Do	28 - 29
Needle & Thread Table	5	Winding the Bobbin	7
		Writing & Monogramming	23

FRONT VIEW

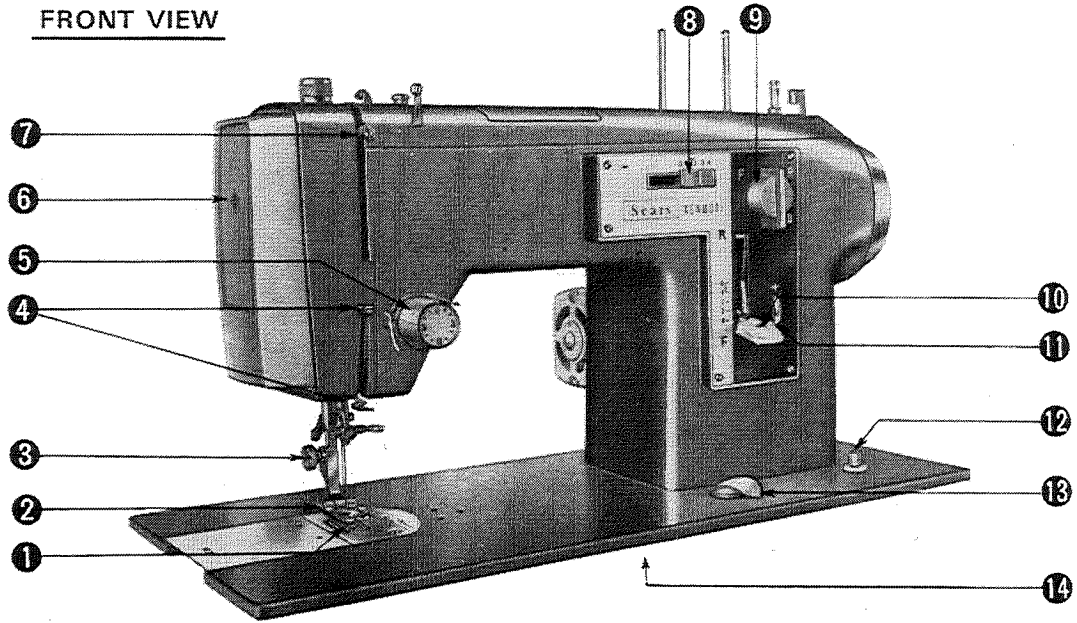

1. Feed Dog
2. Presser Foot
3. Presser Foot Thumb Screw
4. Thread Guides
5. Thread Tension Assembly

6. Face Cover Plate
7. Thread Take-up
8. Stitch Width Control
9. Buttonhole Control Knob
10. Stitch Length Control Lever

11. Buttonhole Reverse Stitch Length Control
12. Light Switch
13. Feed Dog Control Knob
14. Nomenclature Plate

BACK VIEW

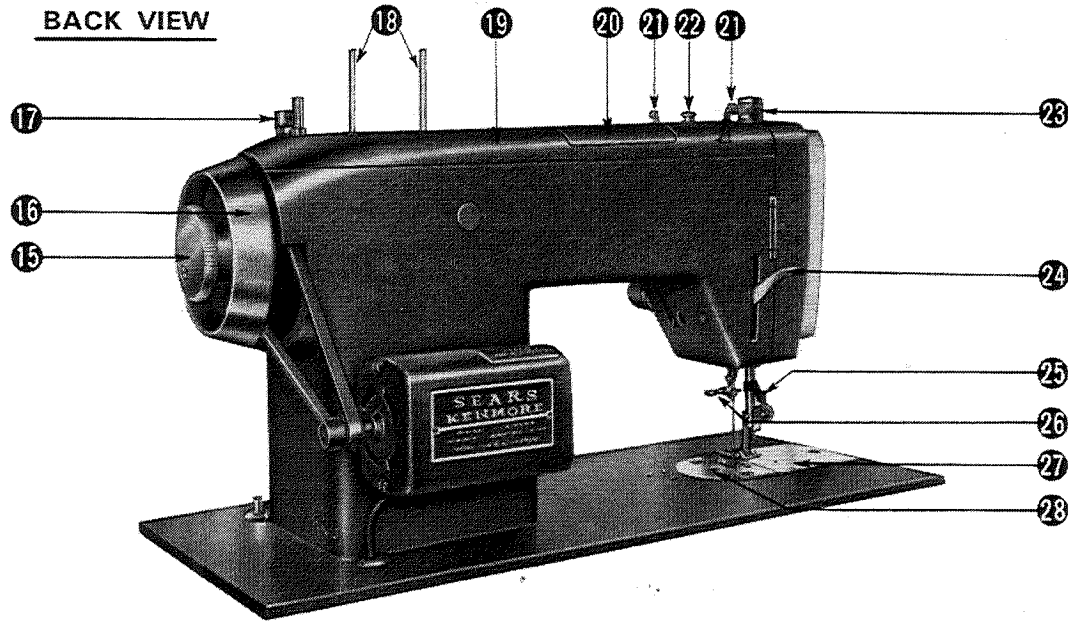

- 15. Clutch Knob
- 16. Hand Wheel
- 17. Bobbin Winder Mechanism
- 18. Thread Spool Pins
- 19. Arm Cover Plate

- 20. Decorative Stitch Mechanism Cover
- 21. Upper Thread Guides
- 22. Bobbin Winder Tension Disc
- 23. Presser Foot Knob

- 24. Presser Foot Lever
- 25. Thread Cutter
- 26. Needle Clamp Screw
- 27. Hand Hole Cover Plate
- 28. Needle Plate

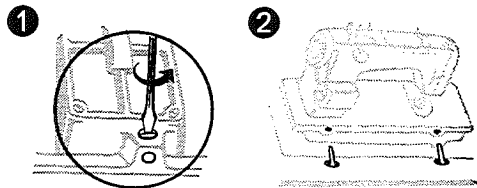

INSTALLING MACHINE HEAD IN PORTABLE AND CABINET

Loosen the two hinge screws under holes in the rear edge of the machine bed (1).

Raise hinge pins in the cabinet cutout (2).

Slip machine head onto the pins and tighten hinge screws securely (3).

Lower machine head to front flap.

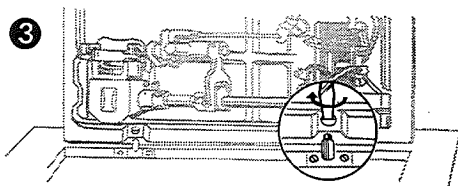

Screw spool pins in place. Lay the plastic discs over the spool pins. Discs and pins are packed in the accessory box.

SEWING LIGHT

The sewing light is placed inside the face cover plate as shown. It may be turned on or off by pushing the light switch. In order to operate the machine the switch must be on.

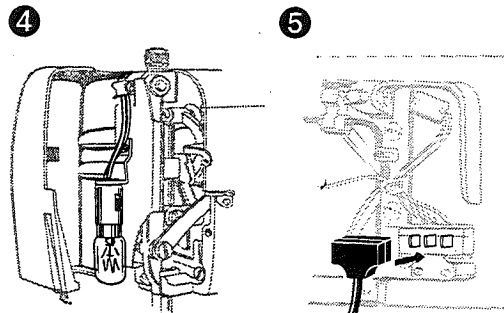

To remove bulb, turn light switch off, open the face cover plate by swinging it open, push bulb in slightly, turn it away from you and remove. To replace, push new bulb in and turn it toward you (4).

CONNECTING MACHINE

Push the plug onto three prong connector under the machine bedplate (5).

Plug machine cord into any 110 - 120V wall outlet.

NEEDLE AND THREAD TABLE

THREAD SIZE	NEEDLE SIZE	FABRIC
Cotton 80 - 100 Synthetic Silk A	9	Chiffon, Fine Silks, Nylon Tricot, Power net.
Cotton 80 - 100 Synthetic Silk A	11	Batiste, Dimity, Organdy, Light weight Velvet and Taffeta, Fine Lace, Light weight Knits, Satin.
Cotton 60 - 80 Synthetic Mercerized 50 - 60	14	Cotton, Cotton Blends, Poplin, Percale, Gingham, Shantung, Pique, Seersucker, Velveteen, Double Knits, Light weight wool, Linen, Leather, Fake Furs, Vinyls.
Cotton 40 - 60 Mercerized 50 Mercerized Heavy Duty	16	Heavy Cotton such as Corduroy, Denim, Decorator Fabrics, Wool, Coating and Suiting.
Cotton 30 - 50 Mercerized Heavy Duty	18	Heavy Twills, Denims, Coatings.

NEEDLE SIZE

Use **KENMORE** 6021 needles. The size of the needle should conform to the size of the thread and both should be suitable to the material. The same size thread should be used in the bobbin as on the upper part of the machine for ordinary sewing. Never use a bent needle nor one with a blunt point.



This is the exact length of the needle to be used in your machine. Comparison with this illustration will determine whether the needle you have is the correct one for your machine.

PLACEMENT OF NEEDLE

Raise needle bar to its highest position by turning hand wheel toward you. Loosen needle clamp screw. Hold needle so that the flat side is to your right, slip blunt end of needle as far as it will go into needle clamp. Tighten needle into place with needle clamp screw.

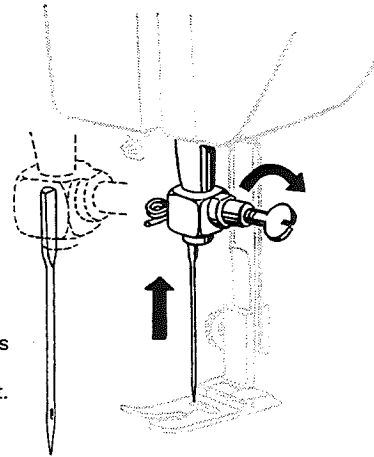

Flat
side
faces
to
right.

REMOVING BOBBIN CASE FROM SHUTTLE

Needle at its highest position.

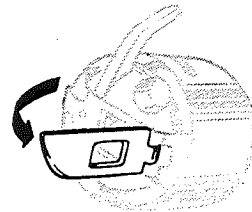
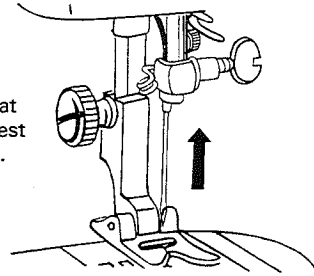

Pull out latch.

Pull bobbin case straight out.

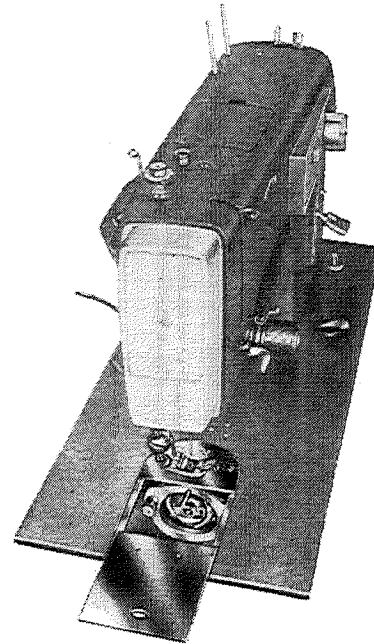
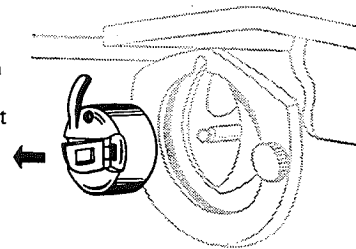

WINDING THE BOBBIN

1

Place thread on spool post. Draw thread as shown.

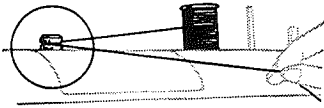

4

Release clutch by turning clutch knob toward you. Start machine.

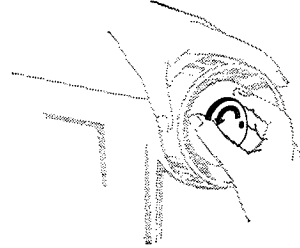

2

Wind thread around bobbin a few times.

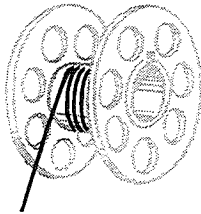

5

When bobbin is full, winding mechanism stops.

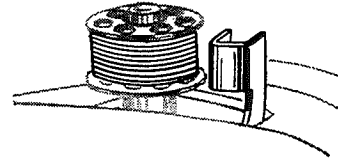

3

Place bobbin onto bobbin winder shaft. Push bobbin winder latch until it clicks.

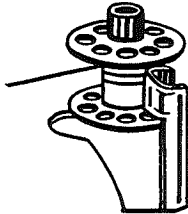

6

Tighten clutch knob and remove bobbin.

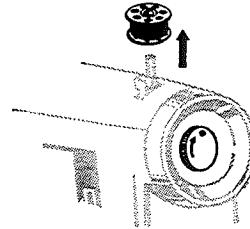

INSERTING BOBBIN INTO BOBBIN CASE CASE INTO SHUTTLE

- 1 Guide bobbin onto center pin of bobbin case.
- 2 Pull thread through slot.
- 3 Pull thread under tension spring.
- 4 Holding latch, position case into shuttle, release latch.

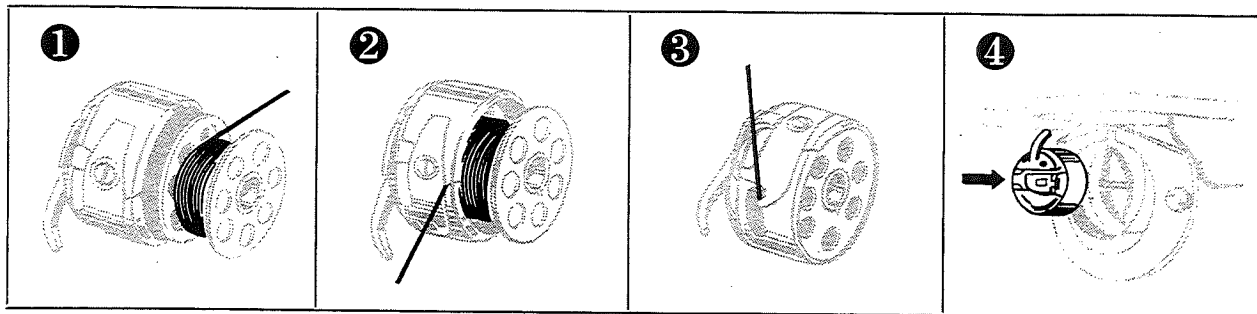

THREADING UPPER MACHINE

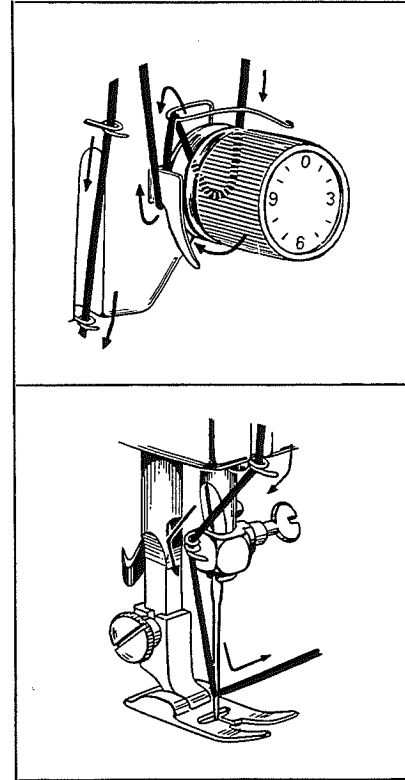
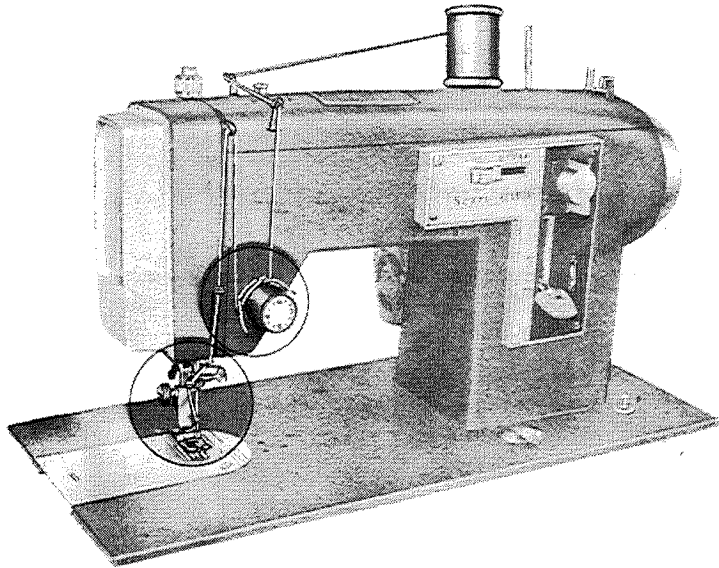

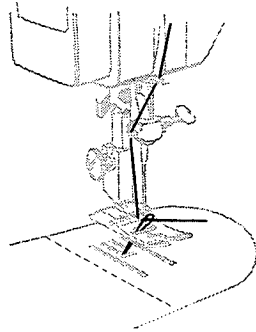

PICKING UP BOBBIN THREAD

Raise presser foot lever.

Hold needle thread loosely in left hand and rotate hand wheel toward you one complete turn.

Bring bobbin thread up by pulling upper thread.
(See illustration).

Place threads back under presser foot.

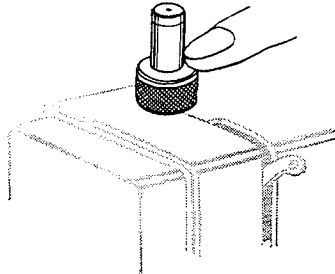

ADJUSTING THE PRESSURE OF THE PRESSER FOOT

Push down outer ring of presser foot knob (See illustration). This will release pressure of presser foot. To increase pressure, push down inner pin until suitable pressure is obtained.

For ordinary sewing, the inner pin should be about half way down. When sewing multiple thickness or heavy material, reduce the pressure. Increase it when sewing sheer fabrics.

Insufficient pressure may cause skipped stitches or difficulty in guiding the fabric. If feed dog or presser foot marks appear on the fabric, reduce the pressure.

SETTING STITCH LENGTH

For all types of sewing other than buttonhole making and blind stitching, the buttonhole control knob (red dot) must be set at C (center needle position).

Loosen knob and move stitch length control lever between 0 and 4 aligning the red mark on the side of the lever with the desired position; tighten knob. The arrow mark indicates the setting for the satin stitch. This will vary slightly depending upon the type of material to be sewn. The 4 setting is the longest stitch. The size of stitch you select will depend on the fabric you want to sew. Select stitch length and tighten knob so that forward and reverse stitches will be approximately the same size.

BASTING

Set stitch length control lever at 4 for the longest possible stitch. Use a paper backing when basting very sheer fabrics.

REVERSE STITCHING

Raise lever for reverse stitching. Lower lever for forward stitching. (Raise or lower lever as far as locking knob will allow). It is best to begin and end most seams with reverse stitching, often called back tacking.

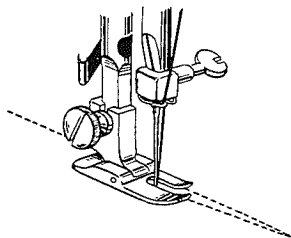
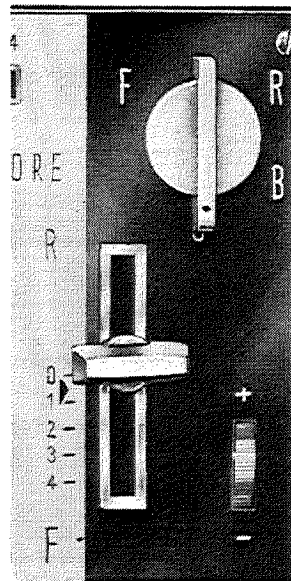

FASTENING A SEAM

Be sure both threads are drawn back under the presser foot. Lower needle into fabric about $\frac{1}{2}$ inch from beginning of seam. Push stitch length control lever up for reverse stitching. Stitch in reverse until needle reaches beginning of seam. Move stitch length control lever down for forward stitching and complete seam. When you reach the end, raise the stitch length control lever and sew back over $\frac{1}{2}$ inch of complete seam.

ADJUSTING TENSIONS

1



Fig. 1

A perfect stitch will have threads locked between the two layers of fabric with no loops on top or bottom. (Refer to page 19).

PROBLEM

REMEDY

2

Upper thread too tight



Fig. 2

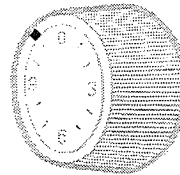

Decrease Tension

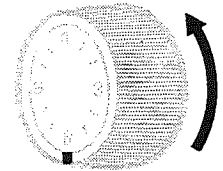

3

Upper thread too loose



Fig. 3

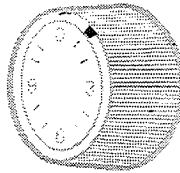

Increase Tension

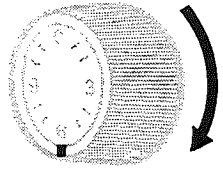

When stitching is unsatisfactory as in figures 2 and 3, adjust the upper thread tension. Lower thread tension requires adjustment less frequently than the upper thread tension.

When stitch is satisfactory, as in figure 1 and seam is badly puckered, the cause may be tight tensions and both upper and lower may be adjusted. (See page 19)

When adjusting the tension on the bobbin case, make slight adjustments with a screw-driver. (See page 19)

It is necessary to reduce the upper thread tension somewhat when doing decorative stitching.

INCREASE TENSION

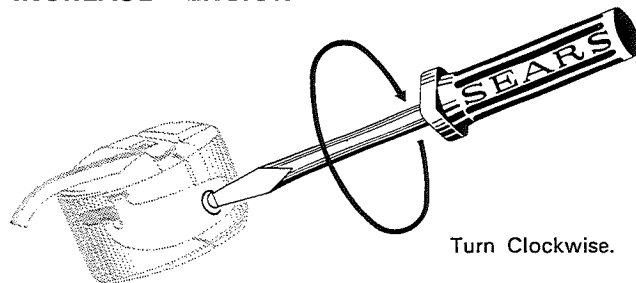

Turn Clockwise.

DECREASE TENSION

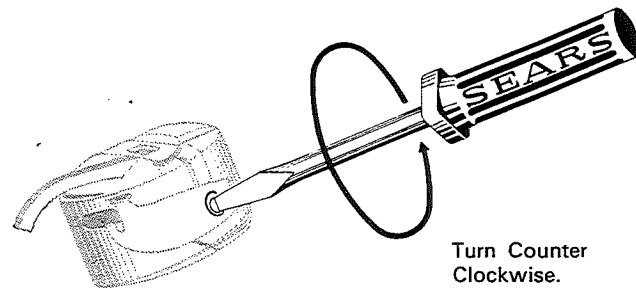

Turn Counter
Clockwise.

INSERTING AND REMOVING THE MATERIAL

For all kinds of sewing, consult chart on page 5.

Before placing the material on the machine see that:

- *The presser foot and needle clamp screws are both tight.
- *The sizes of needle and thread suit the kind of work to be done.
- *The needle and take-up lever are at their highest position.
- *The tensions have been properly adjusted.
- *The ends of the threads have been drawn about 4 inches to the rear of the machine.
- *The feed dogs are up.
- *Stitch length and width controls are set at desired settings.

Experiment by sewing on the fabric to be used to determine tension adjustments and correct stitch settings.

Place material under the presser foot, insert the needle into the material by turning the hand wheel toward you, lower presser foot and start sewing. To facilitate placement of heavy fabrics under the presser foot, the presser foot lever can be raised beyond the normal "up" position.

To remove the work, first turn hand wheel toward you until needle is at its highest position, then raise the presser foot, draw material to the rear and cut off excess thread with the thread cutter located on the presser bar.

IMPORTANT: Always turn the hand wheel toward you! When machine is not being used, place a piece of material over the feed dog and lower the presser foot. Always have fabric under the presser foot when operating the machine. Operating threaded machine without fabric will cause it to jam by forcing thread into the shuttle. See page 25.

TURNING A CORNER

Stop sewing machine with needle in fabric. Raise presser foot. Turn fabric. Lower presser foot and continue stitching.

FEED DOG CONTROL

The feed dog control knob is situated on the right front of machine bedplate. When knob is turned to the left, feed dog drops and does not pull material. This allows the operator freedom of movement of material, as for darning. For regular sewing, turn knob to the right, "U" (Feed dog up).

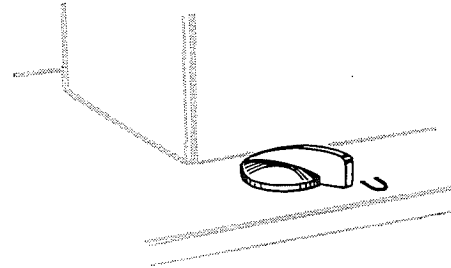

CHANGING THE ATTACHMENT FOOT

The various attachment feet available for certain kinds of work are to be fastened to the presser bar.

To attach the feet, raise the presser bar to its highest position by raising the presser foot lever. Loosen the presser foot thumb screw, choose the proper foot, insert from the front. Tighten the screw using the large screw driver and make sure that the foot is secure.

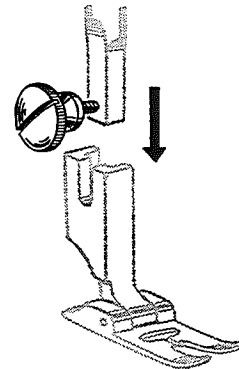

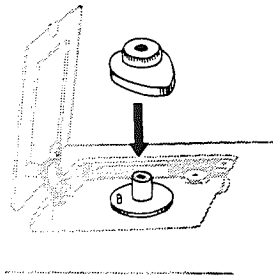
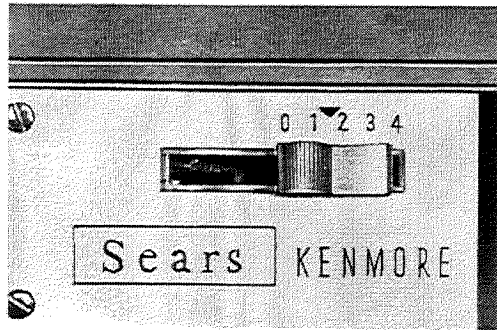

SETTING STITCH WIDTH

Press stitch width control and move so right edge of control is aligned with setting desired. Zigzag width increases from setting 0 to setting 4. Straight stitching is possible only with the control on 0 setting (extreme left) and with no pattern disc in the machine.

DECORATIVE STITCHING

This machine can make beautiful decorative and embroidery stitches by means of various discs supplied with the machine. The movements of the needle are controlled by the disc.

The stitch length specified is for an average pattern of decorative sewing. When a looser or tighter pattern of stitching is preferred, it is achieved by setting the stitch length to a shorter or longer stitch to suit your preference.

The satin stitch requires no pattern disc and can be any width from 1 - 4. It is necessary to reduce the upper thread tension somewhat for decorative stitching. This will prevent the material from puckering and will prevent the bobbin thread from coming up on the top of the fabric.

INSERTING THE DISC

1. Turn handwheel so that the needle is in its highest position.
2. Push stitch width control to the RIGHT and keep it there during insertion.
3. Pull decorative stitch mechanism cover open. Grasp knob of pattern disc and slip onto the shaft. Turn disc slightly until it slips down and the retaining pin enters hole in disc.
4. Return stitch width control to LEFT position.

To remove pattern disc push stitch width control to the RIGHT and pull disc off the shaft.

DECORATIVE STITCHES

Disc No. 0 pattern made on
Buttonhole Control setting B,
all other patterns on setting C.

Stitch width :
Satin stitch 1 - 4
All others 0

Stitch length :
about $\frac{1}{2}$ (arrow)

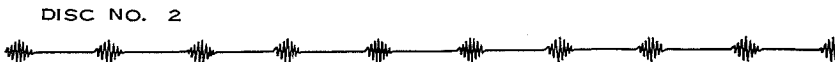

DARNING

WITH PRESSER FOOT :

1. Turn feed dog control to left.
2. Press down outer ring of presser foot knob, see page 10. With presser foot knob in this position, mending, darning, monogram work, etc. may be done.
3. Stretch fabric tightly between two spring embroidery hoops and place under needle.
4. Lower presser bar so thread will have some tension. When you start to darn, move fabric back and forth to cover darning area. Then turn fabric and continue sewing at right angles to the previous stitching. Use medium machine speed. You can make any length stitches desired. Slow movement of fabric will make short darning stitches. Fast movement will make long stitches.
5. When you finish darning, raise presser foot and remove fabric. Increase pressure for general sewing by pressing down inner pin of the presser foot knob. Turn feed dog control to right.

WITHOUT PRESSER FOOT :

1. Turn feed dog control to left.
2. Remove presser foot.
Proceed as directed under steps 3 and 4 above.
3. When you finish darning, raise the presser foot lever and remove fabric. Replace presser foot, and increase pressure for general sewing. Turn feed dog control to right.

ADJUSTING YOUR SEWING MACHINE FOR GOOD STITCHES

When your sewing machine does not sew a properly locked stitch, check the following:

1. Insert a new needle of the correct size for the thread and fabric you are using. Consult chart on page 5 for needle size.
2. The upper and bobbin thread should be matched in size and type.
3. Check threading carefully. See page 9.
4. Check the thread tension balance. Use mercerized thread, and a correct size needle for the fabric you are using. Do not try this test with synthetic thread as it will not break.

Begin with a full bobbin, properly threaded into the case. Set the stitch length at about 12 stitches per inch. Fold a 6" square of your fabric in half diagonally, forming a triangle. Make a line of stitching $\frac{1}{2}$ " from fold.

- a. If seam is puckered - both tensions are too tight.
- b. If the bottom thread lays on the fabric - tighten upper thread tension, and repeat test. See page 12, Figure 3.
- c. If the top thread lays on the fabric - loosen upper thread tension, and repeat test. See page 12, Figure 2.

Grasp the stitching and pull with a snap to make threads break.

- a. If both threads break - tensions are balanced.
- b. If neither thread breaks - both tensions are too loose.
- c. If upper thread breaks - loosen upper tension.
- d. If lower thread breaks - tighten upper tension.

Both threads do not have to break at the same place, but they should break on the same snap.

Bobbin tension may be reset by the following procedure. Start with a loose bobbin thread tension. Tighten the spring screw gradually until bobbin case and full bobbin can be gently lifted from your hand by the end of the bobbin thread.

BUTTONHOLE WITH SPECIAL BUTTONHOLE FOOT

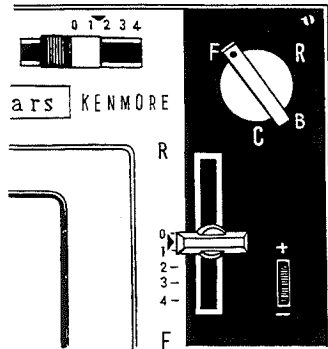

Stitch width control at arrow mark
 Stitch length control at arrow mark
 Buttonhole reverse stitch length control; red line at about center of dial

Special buttonhole foot
 Feed dog control U
 Buttonhole control knob (red dot) F

Place the fabric, with buttonhole length marked at both ends, under the buttonhole foot. Without lowering the foot, let the needle pierce the fabric at the beginning of the buttonhole. Set the front edge of the foot opening about 1/16 inch beyond the mark of the opposite end of the buttonhole. Lower the foot.

- ① Stitch forward until front edge of the foot is reached.
- ② With needle out of material, increase stitch width to 4 and drop feed dog. Pierce fabric with needle, take about 4 stitches to bartack.
- ③ With needle out of material, slide stitch width control back to the arrow mark, set buttonhole control knob on "R", raise feed dog, sew to the other end of the buttonhole.
- ④ With needle out of material, set stitch width on 4, lower feed dog and bartack 3 or 4 stitches. Raise feed dog.

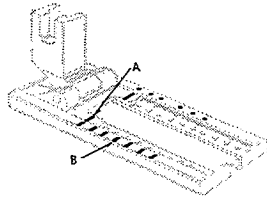

Reproduction of identical size buttonholes is facilitated with the aid of the graduations on the left side of the buttonhole foot. These graduations are $\frac{1}{8}$ inch apart. Just mark the starting points of the buttonholes, let the needle pierce the fabric and set the index mark (A) on the upper portion of the foot at the same graduation mark (B) as it was set for the first buttonhole. Lower the foot. Follow steps 1 to 4 outlined in buttonhole instructions.

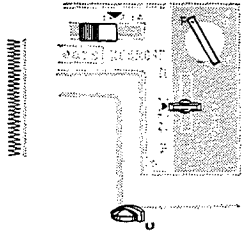
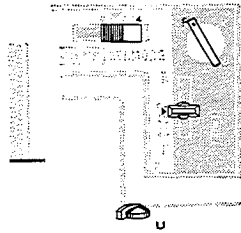
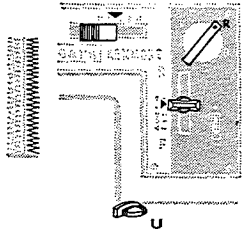
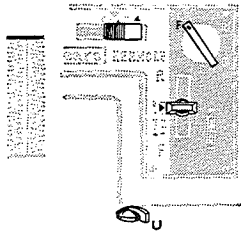
1**2****3****4**

Always make a practice buttonhole on a scrap of fabric used in the garment, using a double thickness of fabric, and an interfacing if used in garment.

The stitch length may be varied slightly by the stitch length control lever within the 0 to 1 range. To increase forward stitch move this lever from the arrow mark toward 1, to decrease move it toward 0.

The buttonhole reverse stitch length control is used to match the length of the reverse stitches with the forward stitches. Turn the dial down for shorter stitches and up for longer stitches. Generally only a slight adjustment of this control is required. Excessive movement of this control will alter the forward stitch length and may reverse the forward motion. These setting may vary depending on type of fabric used.

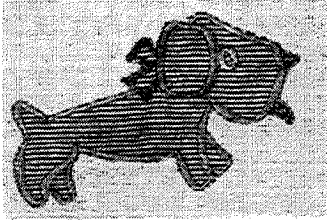

APPLIQUE

Baste cutout applique to fabric. Set stitch width 2 to 4. Set stitch length about $\frac{1}{2}$. Zigzag stitch around applique, completely covering the raw edge.

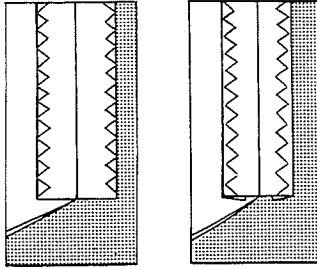

OVERCASTING

Set stitch width to 4. Set stitch length at 3. Zigzag stitch around raw edge of fabric to completely cover the edge.

WRITING AND MONOGRAMMING

Free Hand

Stitch width at 0 to 4

Feed dog control Left

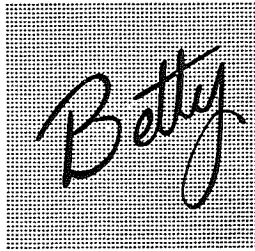

Draw initials or words to be sewn on fabric and fit fabric into embroidery hoops. Writing is done with either zigzag or straight stitching. Remove presser foot. Set stitch width for straight or zigzag stitches as desired. Slip hoop and fabric under the needle, lower presser bar and take one stitch to raise bobbin thread through fabric. Using a medium speed, stitch along marked outline, guiding fabric carefully by hands.

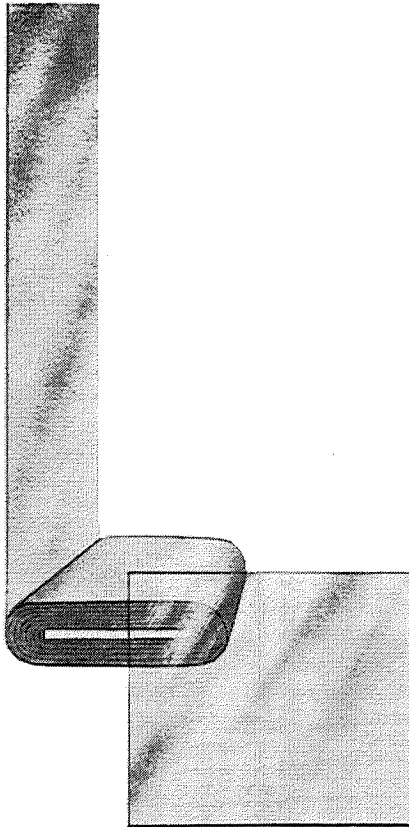

SYNTHETICS

Your KENMORE will sew all the new fabrics of synthetic fiber, such as nylon, *Orlon, **Dacron, rayon, acetate, blends of these, and combinations of synthetic and natural fibers. When stitching a fabric of blended or combined fibers, handle it as you would a material of the fiber present in the largest percentage. For example, a fabric woven of 60% Orlon and 40% silk should be handled as one made entirely of Orlon.

When stitching a fabric that is over 50% synthetic fiber, remember:

- a. Select patterns of the loose fitting type with cap or kimono sleeves, because most synthetic fiber fabrics cannot be eased with steam pressing, and are not absorbent.
- b. Use a synthetic thread.
- c. Use a fine needle as recommended in chart on page 5.
- d. Wind the bobbin in the usual way, but do not pass thread between tension discs. Guide thread by hand for a smoothly wound bobbin.
- e. Choose the stitch length that gives the most satisfactory seam.
- f. Check thread tensions by sewing on a double thickness of the fabric to be used. Usually the upper thread tension must be loosened. Sometimes both bobbin and upper thread tensions must be loosened (pages 12, 13).

SEWING ON PLASTIC FILMS

Set the machine with normal thread tensions and a large size stitch. Use a fine needle and mercerized thread. Hold plastic pieces together with cellophane tape or paper clips rather than pins. Sew corners slightly rounded rather than square.

*Trademark for Dupont's Acrylic fiber. **Trademark for Dupont's polyester fiber.

REMOVING LINT

1. Turn hand wheel toward you until needle is at its highest position. Remove bobbin and bobbin case.
2. Push buttons (A) sideways.
3. Remove shuttle race cover (B). Then pull out shuttle (C) by grasping axle.
4. Remove accumulated lint and thread from all parts of shuttle race.
5. Replace shuttle in race body, with axle facing out, forming a perfect circle with driver (D).
6. Replace shuttle race cover (B), then insert bobbin and bobbin case.
7. Do not attempt to force any of the above operation.
8. Occasionally remove the needle plate and clean feed dog with a soft brush.

REPLACEMENT OF THE BELT

Push motor against machine and remove belt from motor pulley. Let motor down gently. Pull belt out over hand wheel. Install new belt reversing the above procedure.

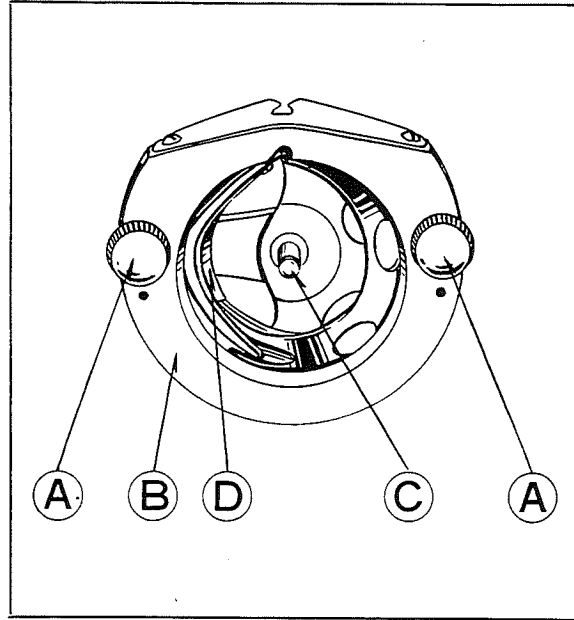

CLEANING AND OILING.....

Keep the moving parts free from dust and threads for quiet and efficient operation. Cleaning should be done with a small brush.

When machine runs hard or makes excessive noise, place a drop of KENMORE sewing machine oil at the points indicated in figs. A, B & C.

Swing hinged face cover plate open to oil points indicated at end of machine head.

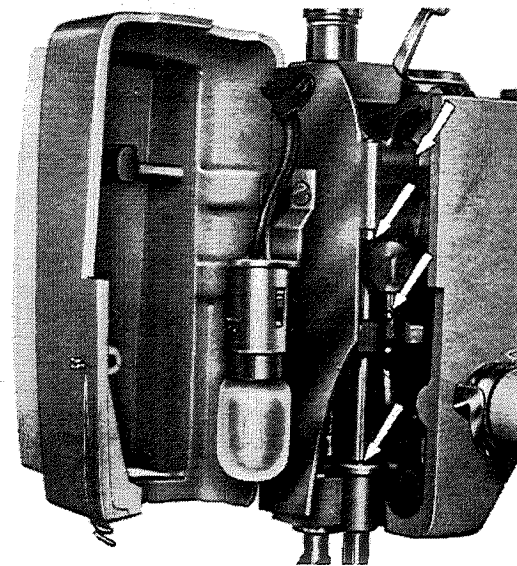
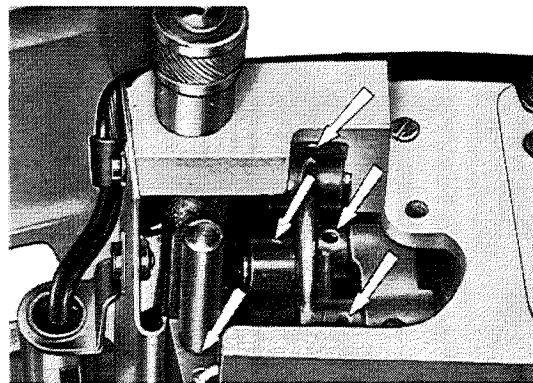

Fig. A

OILING MACHINE

Tilt machine head back to oil points indicated on underside of machine head.

Fig. B

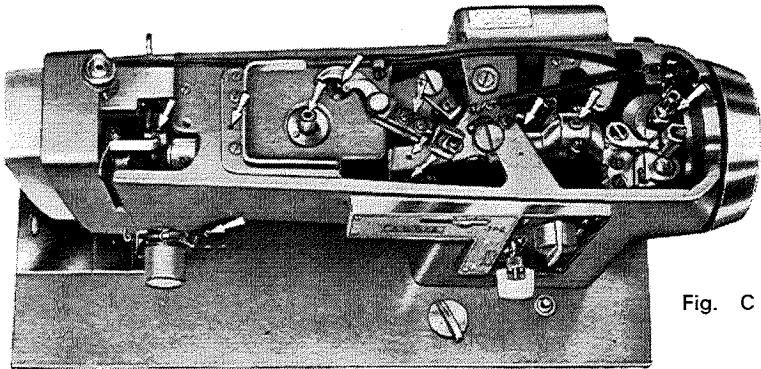
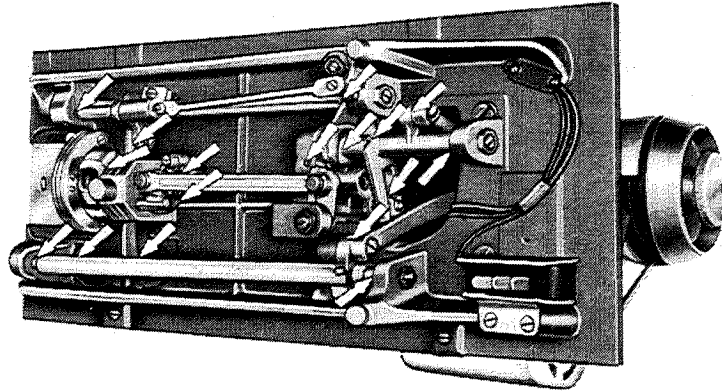

Fig. C

Remove arm cover plate to oil points indicated at top of machine head.

To remove cover plate, remove top screws and lift cover.

WHAT TO DO

PROBLEM	PROBABLE CAUSE	CORRECTION
Irregular Stitches	<p>Incorrect size needle.</p> <p>Improper threading.</p> <p>Loose upper thread tension.</p> <p>Pulling fabric.</p> <p>Light pressure on presser foot.</p> <p>Loose presser foot.</p> <p>Unevenly wound bobbin.</p>	<p>Choose correct size needle for thread and fabric (Page 5).</p> <p>Rethread machine (page 9).</p> <p>Tighten upper thread tension (page 12).</p> <p>Do not pull fabric; guide it gently.</p> <p>Increase pressure on presser foot (page 10).</p> <p>Reset presser foot (page 15).</p> <p>Rewind bobbin (page 7).</p>
Breaking Needle	<p>Pulling fabric.</p> <p>Incorrect size needle.</p> <p>Incorrect setting of needle.</p> <p>Loose presser foot.</p>	<p>Do not pull fabric; guide it gently.</p> <p>Choose correct size needle for thread and fabric (page 5).</p> <p>Reset needle (page 5).</p> <p>Reset presser foot (page 15).</p>
Bunching of Thread	<p>Upper and lower threads not drawn back under presser foot.</p> <p>Feed dog down.</p>	<p>Draw both threads back under presser foot (page 10).</p> <p>Raise feed dog (page 15).</p>
Puckering	<p>Incorrect thread tension(s).</p> <p>Light pressure on presser foot.</p> <p>Using two different sizes or kinds of thread.</p> <p>Bent or blunt needle.</p> <p>Loose presser foot.</p> <p>Fabric too sheer or too soft.</p>	<p>Reset thread tension(s) (pages 12, 13).</p> <p>Increase pressure on presser foot (page 10).</p> <p>Upper thread and bobbin thread should be same size and kind.</p> <p>Insert new needle (page 5).</p> <p>Reset presser foot (page 15).</p> <p>Use underlay of tissue paper or tarleton when stitching.</p>

WHAT TO DO

PROBLEM	PROBABLE CAUSE	CORRECTION
Skipping Stitches	<ul style="list-style-type: none"> Incorrect size needle. Bent or blunt needle. Incorrect setting of needle. Tight upper thread tension. Light pressure on presser foot. 	<ul style="list-style-type: none"> Choose correct size needle for thread and fabric (page 5). Insert new needle (page 5). Reset needle (page 5). Loosen upper thread tension (page 12). Increase pressure on presser foot (page 10).
Breaking Upper Thread	<ul style="list-style-type: none"> Starting to stitch too fast. Improper threading. Tight upper thread tension. Incorrect size needle. Sharp eye in needle. 	<ul style="list-style-type: none"> Start to stitch at a medium speed. Rethread machine (page 8, 9). Loosen upper thread tension (page 12). Choose correct size needle for thread and fabric (page 5). Insert new needle (page 5).
Breaking Bobbin Thread	<ul style="list-style-type: none"> Improper bobbin case threading. Tight bobbin thread tension. Lint in bobbin case or shuttle. 	<ul style="list-style-type: none"> Check bobbin case threading (page 8). Loosen bobbin thread tension (page 13). Clean bobbin case and shuttle (page 25).
Fabric not Moving	<ul style="list-style-type: none"> Feed dog down. Light pressure on presser foot. Threads knotted under fabric. 	<ul style="list-style-type: none"> Raise feed dog (page 15). Increase pressure on presser foot (page 10). Place both threads back under presser foot before beginning to stitch.
Machine Jamming (Knocking Noise)	<ul style="list-style-type: none"> Thread caught in shuttle. 	<ul style="list-style-type: none"> Disassemble and clean shuttle (page 25).

When ordering these parts, please be sure to mention the following references:

1. Model & serial numbers of machine shown on the nomenclature plate. See page 2.
2. Parts number(s) and description(s) here.

When ordering by mail, prices will be furnished on request, or parts will be shipped at prevailing prices and you will be billed accordingly.

<u>Ref. #</u>	<u>Part #</u>	<u>Description</u>	<u>Ref. #</u>	<u>Part #</u>	<u>Description</u>
1	47	Shuttle hook	10	2704	Pattern disc # 5
2	4611	Needle clamp		2705	Pattern disc # 6
3	60502	Bobbin		2706	Pattern disc # 7
4	60404	Bobbin case	11	1222	Bobbin winder thread guide
5	3815	Light bulb	12	3015	Large screw driver
6	6021	Pack of assorted needle	13	3016	Small screw driver
7	1939	Bobbin winder rubber ring	14	*60861	Buttonhole opener
8	2273	Nylon disc	15	*60890	Sewing machine oil
9	8286	Thread spool pin	16	4607	Presser foot
10	3065	Pattern disc # 0	17	135	Presser foot thumb screw
	2700	Pattern disc # 1	18	60902	Motor rubber belt
	2701	Pattern disc # 2	19	60863	Needle threader
	2702	Pattern disc # 3	20	*60860	Bobbin box with 10 bobbins
	2703	Pattern disc # 4	21	60855	Special buttonhole foot

* Items 14, 15 and 20 do not come with the machine, but are available.

MEMO

SEWING MACHINE

Now that you have purchased your Sewing Machine, should a need ever exist for repair parts or service, simply contact any Sears Service Center and most Sears, Roebuck and Co. or Simpsons-Sears Limited Stores. Be sure to provide all pertinent facts when your call or visit.

The model number of your Sewing Machine will be shown on your nomenclature plate on the front side of bedplate of your Sewing Machine. See page 2 for location.

WHEN ORDERING REPAIR PARTS, ALWAYS GIVE THE FOLLOWING INFORMATION:

*MODEL NUMBER *NAME OF ITEM *PART DESCRIPTION

If the parts you need are not stocked locally, your order will be electronically transmitted to a Sears Repair Parts Distribution Center for handling.

**SEARS, ROEBUCK AND CO., Chicago, IL 60684 U.S.A. and
SIMPSONS-SEARS LIMITED, Toronto, Ontario, Canada**