



The Signature of Quality®

Installation & Operation Instructions

Refrigerated LPRSS & ELPRSS Models



Federal Industries
215 Federal AVE
Belleville, WI 53508

Toll Free: (800) 356-4206
WI Phone: (608) 424-3331
Fax: (608) 424-3234



Contents

(1)	Introduction	5
1.1	Serial Number	5
(2)	Warning Labels & Safety Instructions	6
(3)	Pre-Installation Procedures	12
3.1	Inspection for Shipping Damage	12
(4)	General Electrical & Grounding	13
4.1	Electrical Data	13
4.2	Cord Connected	13
4.3	Permanent Connected (Option)	14
(5)	Installation Instructions	15
5.1	“REFRIGERATION WARNING &INSTALLATION-REPAIR-DECOMMISSIONING”	15
5.2	Locating the Display Case	15
5.3	Removing Case From Shipping Skid and General Installation	15
5.4	Cleaning.....	16
5.5	Center Panel Joining (Option).....	16
5.6	Refrigeration System.....	17
5.6.1	Self-Contained Models	17
5.6.2	Remote Models.....	17
5.7	Evaporator Condensate Drain Tube	19
5.8	Condensate Pump.....	20
(6)	Shelving Installation & Removal	21
6.1	Metal Shelves.....	21
6.2	Glass Shelves.....	22
6.3	Optional Shelf Lights - ELPRSS.....	23
(7)	Plastic End Removal & Installation	24
(8)	Rear Doors (Options)	25
(9)	Night Curtain.....	26
(10)	Security Night COVER (Option).....	27
(11)	Operating Instructions	28
11.1	User Controls Overview	28
11.2	Using the electronic control.....	29
11.2.1	Button and Display Overview	29
11.2.2	Powering on control	29
11.2.3	Adjusting the set point	30



11.2.4	Entering manual defrost mode	30
11.2.5	Error codes	30
11.3	Initial Startup	31
11.4	Placing Product in Case	31
(12)	Maintenance	32
12.1	Light Replacement	32
(13)	Periodic Maintenance	33
13.1	Cleaning Condenser Coil	33
(14)	Cleaning Instructions	34
14.1	Daily Cleaning.....	34
14.2	Weekly Cleaning.....	34
(15)	Sale & Disposal.....	37
15.1	Owner Responsibility	37
(16)	Service Information.....	38
16.1	Pre-Service checklist	39
16.1.1	Case does not operate.....	39
16.1.2	Lights do not operate	39
16.1.3	Case temperature too warm (product is exceeding 41°F)	39
16.2	Special Service Instructions	39
16.3	Electronic Control Operation	40
16.3.1	Operation	40
16.3.2	Defrost Cycle	40
16.4	Error Codes	41
16.5	Refrigeration Operation.....	41
16.5.1	Self-Contained Models.....	41
16.5.2	Remote Models	42
(17)	Wiring Diagrams.....	43
17.1	Self Contained.....	43
17.2	Remote.....	44
(18)	Replacement Parts.....	45



Tables

Table 1 - Electrical Ratings	13
Table 2 - Shelf Loading Limits	31
Table 3 - Error Codes and Resolutions.....	41
Table 4 - Temperature Probe Common Resistance Chart	41



(1) INTRODUCTION

Thank you for purchasing a Federal Industries display case. This manual contains important instructions for installing and servicing the LPRSS refrigerated self-service merchandisers. A repair parts list and wiring diagram are also included in the manual. Read all of these documents carefully before installing or servicing your case.

	<p>NOTICE</p> <p>Read this manual before installing your case. Keep this manual and refer to it before doing any service on the equipment. Failure to do so could result in personal injury or damage to the case.</p>
	<p>NOTICE</p> <p>Installation and service of the electrical components in the case must be performed by a licensed electrician.</p> <p>The portions of this manual covering components contain technical instructions intended only for persons qualified to perform electrical work.</p>
	<p>DANGER</p> <p>Improper or faulty hookup of electrical components in the case can result in severe injury or death.</p> <p>All electrical wiring hookups must be done in accordance with all applicable local, regional, or national standards.</p>

1.1 SERIAL NUMBER

Record the model and serial numbers of the case for easy reference. Always refer to both model and serial numbers in your correspondence with Federal regarding the case.

Case Model _____ Serial Number _____
Condensing Unit Model _____ Serial Number _____

This manual cannot cover every installation, use, or service situation. If you need additional information, call or write us:

WARRANTY/TECHNICAL SERVICE DEPARTMENT

Federal Industries

215 Federal AVE

Belleville, WI 53508

Toll Free (800) 356-4206 / WI Phone (608) 424-3331

(2) WARNING LABELS & SAFETY INSTRUCTIONS



This is the safety-alert symbol. When you see this symbol on your case or in the manual, be alert to the potential for personal injury or damage to your equipment.

Be sure you understand all safety messages and always follow recommended precautions and safe operating procedures.



NOTICE TO EMPLOYERS

You must make sure that everyone who installs, uses, or services your case is thoroughly familiar with all safety information and procedures.

Important safety information is presented in this section and throughout the manual. The following signal words are used in the warning and safety messages:

DANGER: Severe injury or death will occur if you ignore the message.

WARNING: Severe injury or death can occur if you ignore the message.

CAUTION: Minor injury or damage to your case can occur if you ignore the message.

NOTICE: This is important installation, operation, or service information. If you ignore the message, you may damage your case.

The warning and safety labels shown throughout this manual are placed on your Federal Industries case at the factory. Follow all warning label instructions. If any warning or safety labels become lost or damaged, call our customer service department at 1(800)

356-4206 for replacements.

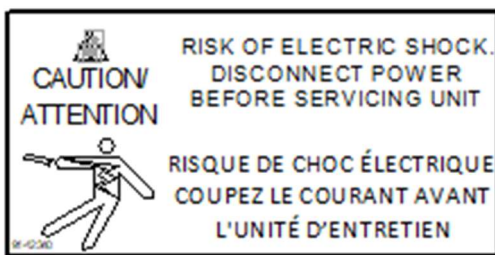

This label is located behind the removable base deck panels display and under deck pans.



This label is located under display

DANGER – Risk of fire or explosion. Flammable refrigerant used. Consult repair manual/owner's guide before attempting to service this product. all safety precautions must be followed 91-2181-4

DANGER — Risque d'incendie ou d'explosion. Fluide frigorigène utilisé. Consulter le guide propriétaire ou le manuel de réparations avant de d'essayer d'installer ou de réparer ce produit. Toutes les précautions de sécurité doivent être suivies. 91-2181-4

This label is located by condensing unit

REFRIGERATION WARNING

INSTALLATION-REPAIR-DECOMMISSIONING



This is the Danger-Flammable symbol. When you see this symbol on your case or in the manual, be alert to the potential for risk of fire or explosion.

Be sure you understand all the safety messages and always follow recommended precautions and safe operating procedures.

DANGER



Risk of fire or explosion. Flammable refrigerant used. To be repaired only by trained service personnel. Do not puncture refrigerant tubing. Dispose of properly in accordance with federal or local regulations

Consult repair manual/owner's guide before attempting to service this product. All safety precautions must be followed.

Follow handling instructions carefully in compliance with national regulations.

Auxiliary devices which may be ignition sources shall not be installed in the ductwork, other than auxiliary devices listed for use with the specific appliance.

Do not store explosive substances (such as aerosol cans with a flammable propellant) in this case.

Do not use an electrical appliance INSIDE the food storage compartments unless its type is recommended by manufacturer.

Flammable refrigerant type specified on case nameplate is on the serial label.

APPLIES TO R290 REFRIGERANT MODELS ONLY! Contains a charge of R290 refrigerant with a lower flammability limit (LFL) of .038kg/m³. See table for amount of charge.

WARNING

- Do not use means to accelerate the defrosting process or to clean, other than those recommended by the manufacturer.
- The appliance shall be stored in a room without continuously operating ignition sources
For example: open flames, an operating gas appliance or an operating electric heater.
- Do not pierce or burn.
- Be aware that refrigerants may not contain an odor.

MISE EN GARDE

- Ne pas utiliser de moyens autres que ceux recommandés par le fabricant pour accélérer le processus de dégivrage ou pour nettoyer l'appareil.
- L'appareil doit être entreposé dans un local ne contenant pas de sources d'inflammation permanentes (flammes nues, appareil à gaz ou dispositif de chauffage électrique en fonctionnement, par exemple).
- Ne pas percer ou brûler.
- Attention, les fluides frigorigènes peuvent ne pas dégager d'odeur.

3. Qualification: All refrigeration and electrical maintenance, service, and repair must be performed by a Certified Technician that is trained in the required flammable refrigerants safety procedures. Technicians must read the entire section “REFRIGERATION WARNINGS SECTION” of this manual. Including but not limited to the following:

- a) breaking into the refrigerating circuit.
- b) opening of sealed components.
- c) opening of ventilated enclosures.

4. Checks to Area: Prior to beginning work on systems containing FLAMMABLE REFRIGERANTS, safety checks are necessary to ensure that the risk of ignition is minimized prior to conducting work on the system.

- Capacitors are discharged: this shall be done in a safe manner to avoid the possibility of sparking.
- No live electrical components and wiring are exposed while charging, recovering or purging the system.
- Continuity of earth bonding.
- Work shall be undertaken under a controlled procedure to minimize the risk of a flammable gas or vapor being present while the work is being performed.
- All maintenance staff and others working in the local area shall be instructed on the nature of the work being carried out. Work in confined spaces shall be avoided.

-The area shall be checked with an appropriate refrigerant detector prior to and during work, to ensure the technician is aware of potentially toxic or flammable atmospheres. Ensure that the leak detection equipment being used is suitable for use with all applicable refrigerants, i.e., non-sparking, adequately sealed, or intrinsically safe.

-If any hot work is to be conducted on the refrigerating equipment or any associated parts, appropriate fire extinguishing equipment shall be available on hand. A dry chemical or CO2 fire extinguisher should be adjacent to the charging area.

-No person carrying out work in relation to a REFRIGERATING SYSTEM which involves exposing any pipe work shall use any sources of ignition in such a manner that it may lead to the risk of fire or explosion. All possible ignition sources, including cigarette smoking, should be kept sufficiently far away from the site of installation, repairing, removing and disposal, during which refrigerant can possibly be released to the surrounding space. Prior to work taking place, the area around the equipment shall be surveyed to make sure that there are no flammable hazards or ignition risks. "No Smoking" signs shall be displayed.

-Ensure that the area is in the open or that it is adequately ventilated before breaking into the system or conducting any hot work. A degree of ventilation shall continue during the period that the work is carried out. The ventilation should safely disperse any released refrigerant and preferably expel it externally into the atmosphere.

-Where electrical components are being changed, they shall be fit for the purpose and to the correct specification so as to minimize the risk of possible ignition due to incorrect parts. At all times, the manufacturer's maintenance and service guidelines shall be followed. If in doubt, consult the manufacturer's technical department for assistance. The following checks shall be applied to installations using flammable refrigerants:

- a) the actual REFRIGERANT CHARGE is in accordance with the room size within which the refrigerant containing parts are installed.
- b) The ventilation machinery and outlets are operating adequately and are not obstructed.
- c) Markings of the equipment continue to be visible and legible. Markings and signs that are illegible shall be corrected.
- d) Refrigerating pipes or components are installed in a position where they are unlikely to be exposed to any substance which may corrode refrigerant containing

-Repair and maintenance to electrical components shall include initial safety checks and component inspection procedures. If a fault exists that could compromise safety, then no electrical supply shall be connected to the circuit until it is satisfactorily dealt with. If the fault cannot be corrected immediately but it is necessary to continue operation, an adequate temporary solution should be used. This shall be reported to the owner of the Initial safety checks shall include:

5. Repairs to sealed components

-During repairs to sealed components, all electrical supplies shall be disconnected from the equipment being worked upon prior to any removal of sealed covers, etc. If it is necessary to have an electrical supply to equipment during servicing, then a permanently operating form of leak detection shall be located at the most critical point to warn of a potentially hazardous situation.

-Particular attention shall be paid to the following to ensure that by working on electrical components, the casing is not altered in such a way that the level of protection is affected. This shall include damage to cables, excessive number of connections, terminals not made to original specification, damage to seals, incorrect fitting of glands, etc. Ensure that the apparatus is mounted securely.

Ensure that seals or sealing materials have not degraded to the point that they no longer serve the purpose of preventing the egress of flammable atmospheres. Replacement parts shall be in accordance with the manufacturer's specifications.

-Do not apply any permanent inductive or capacitance loads to the circuit without ensuring that this will not exceed the permissible voltage and current permitted for the equipment in use.

NOTE The use of silicon sealants can inhibit the effectiveness of some types of leak detection equipment. Intrinsically safe components do not have to be isolated prior to working on them.

8. Detection of flammable refrigerants: Under no circumstances shall potential ignition sources be used in the searching for or detection of refrigerant leaks. A halide torch (or any other detector using a naked flame) shall not be used.

The following leak detection methods are deemed acceptable for all refrigerant systems:

-Electronic leak detectors may be used to detect refrigerant leaks but, in the case of FLAMMABLE REFRIGERANTS, the sensitivity might not be adequate or might need recalibration. (Detection equipment shall be calibrated in a refrigerant-free area.) Ensure that the detector is not a potential source of ignition and is suitable for the refrigerant used. Leak detection equipment shall be set at a percentage of the LFL of the refrigerant and shall be calibrated to the refrigerant employed, and the appropriate percentage of gas (25 % maximum) is confirmed.

-Leak detection fluids are also suitable for use with most refrigerants but the use of detergents containing chlorine shall be avoided as the chlorine can react with the refrigerant and corrode the copper pipework.

NOTE Examples of leak detection fluids are

- bubble method,
- fluorescent method agents.

If a leak is suspected, all naked flames shall be removed/extinguished.

If a leakage of refrigerant is found which requires brazing, all the refrigerants shall be recovered from the system, or isolated (by means of shut off valves) in a part of the system remote from the leak.

9. Removal and Evacuation:

When breaking into the refrigerant circuit to make repairs-or for any other purpose-conventional procedures shall be used. However, for flammable refrigerants it is important that the best practice be followed, since flammability is a consideration. The following procedure shall be adhered to:

- a. Safely remove refrigerant following local and national regulations.
- b. Purge the circuit with inert gas.
- c. Evacuate (optional for A2L).
- d. Purge with inert gas (optional for A2L).
- e. Open the circuit by cutting or brazing.

The refrigerant change shall be recovered into the correct recovery cylinders if venting is not allowed by local and national codes. For appliances containing flammable refrigerants, the system shall be purged with oxygen-free nitrogen to render the appliance safe for flammable refrigerants. This process might need to be repeated several times. Compressed air or oxygen shall not be used for purging refrigerant systems. For appliances containing flammable refrigerants, refrigerant purging shall be achieved by breaking the vacuum in the system with oxygen-free nitrogen and continuing to fill until the working pressure is achieved, then venting to atmosphere, and finally pulling down to a vacuum (optional for A2L). This process shall be repeated until no refrigerant is within the system (optional for A2L). When the final oxygen-free nitrogen change is used, the system shall be vented down to atmospheric pressure to enable work to take place. Ensure that the outlet for the vacuum pump is not close to any potential ignition sources and that ventilation is available.

10. Charging procedures:

In addition to conventional charging procedures, the following requirements shall be followed.

- a. Ensure that contamination of different refrigerants does not occur when using charging equipment. Hoses or lines shall be as short as possible to minimize the amount of refrigerant contained in them.
- b. Cylinders should be kept in an appropriate position according to the instructions.
- c. Ensure that the REFRIGERATING SYSTEM is earthed prior to charging the system with refrigerant.
- d. Label the system when charging is complete (if not already).
- e. Extreme care shall be taken not to overfill the REFRIGERATING SYSTEM.

11. Decommissioning:

Before carrying out this procedure, it is essential that the technician is completely familiar with the equipment and all its details. It is recommended good practice that all refrigerants are recovered safely. Prior to the task being carried out, an oil and refrigerant sample shall be taken in case analysis is required prior to re-use of recovered refrigerant. It is essential that electrical power is available before the task commences.

- a. Become familiar with the equipment and its operation.
- b. Isolate the system electrically.
- c. Before attempting the procedure, ensure that:
 - i. Mechanical handling equipment is available, if required, for handling refrigerant cylinders.
 - ii. All personal protective equipment is available and is being used correctly.
 - iii. The recovery process is supervised at all times by a competent person.
 - iv. Recovery equipment and cylinders conform to the appropriate standards.
- d. Pump down the refrigerant system, if possible.
- e. If a vacuum is not possible, make a manifold so that refrigerant can be removed from various parts of the system.
- f. Make sure that the cylinder is situated on the scales before recovery takes place.
- g. Start the recovery machine and operate in accordance with instructions.
- h. Do not overfill cylinders (no more than 80% volume liquid charge).
- i. Do not exceed the maximum working pressure of the cylinder, even temporarily.

- j. When the cylinders have been filled correctly and the process completed, make sure that the cylinders and the equipment are removed from the site properly and all isolation valves on the equipment are closed off.
- k. Recovered refrigerant shall not be charged into another refrigerating system unless it has been cleaned and checked.

12. Labeling:

Equipment shall be labeled stating that it has been de-commissioned and emptied of refrigerant. The label shall be dated and signed. For appliances containing flammable refrigerants, ensure that there are labels on the equipment stating the equipment contains flammable refrigerant.

13.Recovery:

When removing the refrigerant from a system, either for servicing or decommissioning, it is recommended good practice that all refrigerants are removed safely.

When transferring refrigerant into cylinders, ensure that only appropriate refrigerant recovery cylinders are employed. Ensure that the correct number of cylinders for holding the total system charge is available. All cylinders to be used are designated for the recovered refrigerant and labeled for that refrigerant (i.e., special cylinders for the recovery of refrigerant). Cylinders shall be complete with pressure-relief valve and associated shut-off valve in good working order. Empty recovery cylinders are evacuated and, if possible, cooled before recovery occurs.

The recovery equipment shall be in good working order with a set of instructions concerning the equipment that is at hand and shall be suitable for the recovery of all appropriate refrigerants including, when applicable, FLAMMABLE REFRIGERANTS. In addition, a set of calibrated weighing scales shall be available and in good working order. Hoses shall be complete with leak-free disconnect coupling and in good condition. Before using the recovery machine, check that it is in satisfactory working order, has been properly maintained and that any associated electrical components are sealed to prevent ignition in the event of refrigerant release. Consult manufacturer if in doubt.

The recovered refrigerant shall be returned to the refrigerant supplier in the correct recovery cylinder, and the relevant waste transfer note arranged. Do not mix refrigerants in recovery units and especially not in cylinders.

If compressors or compressor oils are to be removed, ensure that they have been evacuated to an acceptable level to make certain that FLAMMABLE REFRIGERANT does not remain within the lubricant. The evacuation process shall be carried out prior to returning the compressor to the suppliers. Only electric heating to the compressor body shall be employed to accelerate this process. When oil is drained from a system, it shall be carried out safely.

(3) PRE-INSTALLATION PROCEDURES

3.1 INSPECTION FOR SHIPPING DAMAGE

You are responsible for filing all freight claims with the delivering truck line. Inspect all cartons and crates for damage as soon as they arrive. If damage is noted to shipping crates, cartons, or if a shortage is found, note this on the bill of lading (all copies) prior to signing.

If damage is discovered when the case is uncrated, immediately call the delivering truck line and follow up the call with a written report indicating concealed damage to your shipment. Ask for an immediate inspection of your concealed damage item. Crating material must be retained to show the inspector from the truck line.

(4) GENERAL ELECTRICAL & GROUNDING



DANGER:

Improper or faulty hookup of electrical components in the display case can result in severe injury or death.

4.1 ELECTRICAL DATA

Table 1 - Electrical Ratings

MODEL	SELF CONTAINED			REMOTE		
	VOLTAGE	AMPERAGE	CORD STYLE	VOLTAGE	AMPERAGE	
LPRSS3 ELPRSS3	120/60/1	10.4	20AMP NEMA 5-15P	120/60/1	3	
LPRSS4 ELPRSS4	120/60/1	10.4	20AMP NEMA 5-15P	120/60/1	3	
LPRSS5 ELPRSS5	230/60/1	9.6	15AMP NEMA 6-15P	120/60/1	2	
LPRSS6 ELPRSS6	230/60/1	9.6	15AMP NEMA 6-15P	120/60/1	2	

4.2 CORD CONNECTED

All standard models are supplied with a power cord that is properly sized to the amperage requirements of the case. See the electrical data plate located on the rear left interior ceiling of the case for the proper circuit size for each case.

The cord is factory installed protruding from the bottom rear corner of the case.

A separate circuit for each display case is required to prevent other appliances on the same circuit from overloading the circuit and causing malfunction.

4.3 **PERMANENT CONNECTED (OPTION)**

Only a licensed electrician must perform all case electrical connections.

All electrical wiring hookups must be done in accordance with all applicable local, regional, or national electrical standards.

A separate circuit for each display case is required to prevent other appliances on the same circuit from overloading the circuit and causing malfunction.

The electrical service must be grounded upon installation.

See the electrical data plate located at the rear of the case for proper circuit size and wire ampacity.

The electrical connection box is accessible from the rear of the case with rear grill removed.

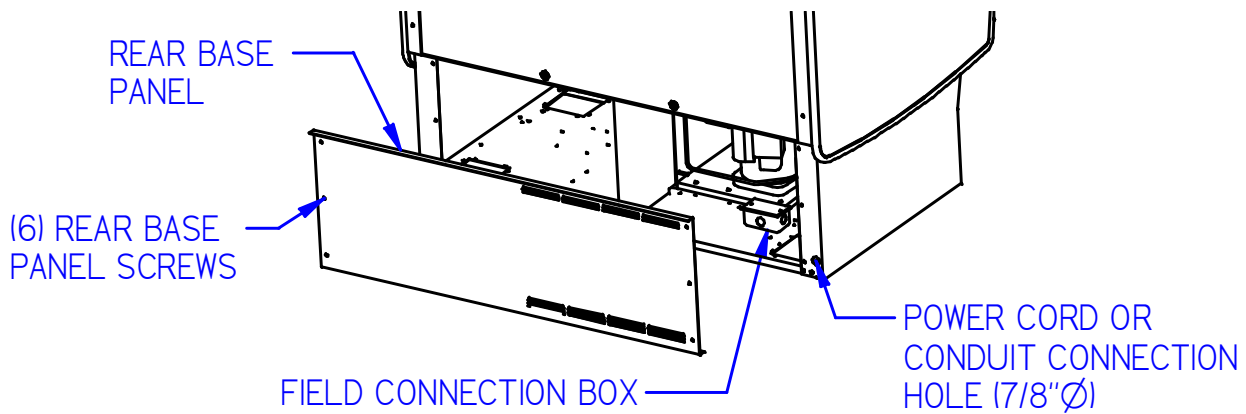

(5) INSTALLATION INSTRUCTIONS

IMPORTANT: Read this Section of this manual located on page 7.

5.1 “REFRIGERATION WARNING & INSTALLATION-REPAIR-DECOMMISSIONING”

All refrigeration and electrical work must be performed by certified technicians.

The installation of the appliance and the refrigerant must only be performed by Federals approved Service or suitably qualified person.

Appliance to be installed in accordance with safety standards ANSI/ASHREA 15.

The appliance shall not be installed in public corridors or lobbies.

This case is designed for a class 2 environment.

<u>Test room climate class</u>	<u>Dry bulb temperature [°F]</u>	<u>Relative Humidity [%]</u>	<u>Dew point [°F]</u>	<u>Water vapour mass in dry air [lbm water/lbm air]</u>	<u>Required Test Lab Temperature [°F]</u>
2.0	71.6	65	59.36	0.0108	89.6

NSF TYPE 1 Temperature cannot exceed 75 deg F and 55% humidity.

5.2 LOCATING THE DISPLAY CASE

The case should be located where it is not subjected to the direct rays of the sun, heating ducts, grills, radiator, or ceiling fans, nor should it be located near open doors or main door entrances. Also, avoid locations where there are excessive air movement or air disturbances.

The case requires a minimum of 6 inches of clearance at the rear of the unit for air discharge. Do not locate case with back tight against the wall. The louvers located on front of base must remain clear for air intake. If rear clearance or front clearance is not possible see a Federal representative for air intake and discharge kit options.

No clearance is needed on sides of the unit.

5.3 REMOVING CASE FROM SHIPPING SKID AND GENERAL INSTALLATION



CAUTION:

Do not push or pull against the top panel, plastic end, end glass, or door frames when removing the case from the skid or moving the case. Case damage or glass breakage could result.

1. Remove crate top and sides and note missing or damaged items as explained in the pre-installation procedures outlined above.
2. Move the case as near as possible to the final location and before removing it from the shipping skid.
3. Remove the (4) brackets that secure the case to the shipping skid.
4. Prepare cabinet according to instructions in this section that pertain to your model.
5. Lift the case off of skid and into required position. Only lift the case from under the rear lip and front bottom trim channel above the base. Note: Do not push or pull on front bottom trim channel or lift using the plastic end panel.

6. The case must be level for proper drainage of defrost condensate to the condensate evaporator. Using the wrench provided level and square the case as needed by adjusting the leg leveler in each corner of base. The 6ft cases also have a set of leg levelers in the center. These must be adjusted so the base is flat.
7. The leveled case must be sealed to the floor using a NSF listed sealant.

5.4 **CLEANING**

For initial setup, clean the case as outlined in the “Weekly Cleaning” section of this manual.

5.5 **CENTER PANEL JOINING (OPTION)**

If your cases were ordered with the Center Panel Joining Option, you will need to perform the following installation procedures.

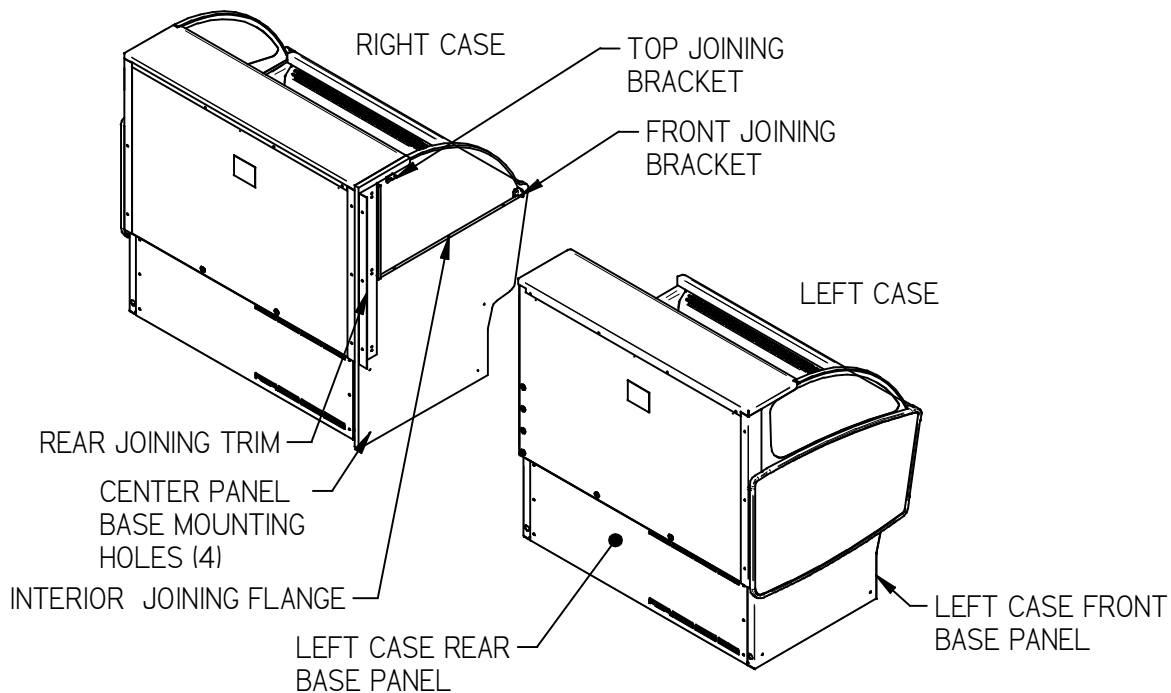

1. Place the right case into desired location and level case by adjusting leg levelers with provided wrench.
2. Remove the front base panel (4) screws and rear base panels (6) screws from the left case. Push the left case end tightly against the right case end. The rear joining trim on the right case must be behind the back panel of the left case and the front joining bracket on the right case must be inside the front aluminum trim channel of the left case.
3. Adjust the leg levelers on the left case so it is level and exactly aligned with the right case. The (4) base mounting hole in the right case panel must align with the (4) mounting holes located in base compartment of left case.
4. Push the cases together as tightly as possible and the gap between the cases must be tight and even. If the gap is larger at the top or the bottom adjust leg levelers accordingly. **HOLD CASES TOGETHER AS TIGHT AS POSSIBLE WHILE ATTACHING ALL JOINING BRACKETS AND DO NOT OVER TIGHTEN SCREWS OR SCREWS WILL STRIP OUT.**
5. Attach the bottom of the left case to the right case center panel base mounting holes through the holes located inside of the left case base. Use the (4) large 10-12x1/2 screws provided.

6. Attach the rear top of left case through the holes in the rear joining bracket using the (3) black #10-12x1/2 self-drilling screws provided.
7. Attach the front of left case through the holes in the front joining bracket using the (2) smaller #8-12x1/2 self-drilling screws provided.
8. Attach the top of left case through the holes in the top joining bracket using the (2) smaller #8-12x1/2 self-drilling screws provided.
9. Attach the interior of left case through the holes in the interior joining flange using the (3) smaller #8-12x1/2 self-drilling screws provided
10. If any there are any gaps along the joining seam fill them with NSF black silicone.
11. Reinstall front and rear grills.

5.6 **REFRIGERATION SYSTEM**

5.6.1 **Self-Contained Models**

The self-contained models are shipped from the factory with a completely operational refrigeration system and require no modifications or adjustments upon installation. Case must be installed as per the installation section of this manual to provide proper condensing air cooling.

Dual Pressure Control (Self-Contained Models Only)

The dual pressure control is used as a safety device and is factory set. The pressure control works on a differential. The low-pressure side is a safety to protect the compressor in the case of refrigerant loss. The high-pressure side is a safety to protect from system failure causing too high of system pressure.

The high side of the pressure control is factory set to 400psi and is not adjustable.

Low side setting for cases are set at 40psi differential for the cutout and 60psi for the cut-in.

5.6.2 **Remote Models**

The remote models are shipped from the factory with the evaporator coil, expansion valve, sight glass, service valves and refrigerant solenoid valve. Installation must be performed by a licensed Refrigeration Technician. See the Service section of this manual for installation requirements.

Electronic Expansion Valve (EEV) After 1/20 On Remote Cases Only

A traditional TXV uses springs and a temperature bulb to open and close a valve port that controls the flow of refrigerant entering the evaporator coil. An electronic expansion valve (EEV) controls the refrigerant flow much more precisely, increasing the performance and efficiency of the refrigeration system. The EEV controls the flow of Refrigerant by opening and closing the valve port based on the response to signals sent to the EEV by an electronic controller. The electronic Control bases these signals by processing information provided from a temperature sensor and pressure transducer located on the discharge side of the evaporator coil.

These sensors monitor the evaporator superheat and protects the compressor from any liquid flood back under low superheat conditions.

EEV Controller Settings

The electronic expansion valve controller also allows the use of different types of refrigerants without the need to change the expansion valve.

The controller is set from the factory to run on 449A refrigerant and will not need any changes to the control unless another refrigerant is used.

Note: Check your State and Local regulations for approved refrigerants for your install location. Federal Industries is not liable for any alternate refrigerants used.





The control is located in the base of the case to the left of the electrical connection box.

Note: Never change any of the other settings other than the refrigerant type. It may also be necessary to change the superheat setting only when using a different refrigerant.





Indicator lights	
	Red light - critical alarm (system is NOT running)
	Yellow light - non-critical alarm (system running)
	Green light - compressor on
	Green blinking - compressor waiting on timer to start/stop



Changing Refrigerant

- Access the set point mode by pressing and holding the **ENTER** button until Ctl displays on the screen.
- Use the  up or  down arrows to advance through the available set points until rFG displays on the screen and press the **ENTER** button.
- Use the  up or  down arrows until the desired refrigeration displays on the screen and press and hold the **ENTER** button until rFG once again displays on the screen.
- Press the **BACK** to return to escape the settings menu.

Changing Superheat

- Access the set point mode by pressing and holding the **ENTER** button until Ctl displays on the screen.
- Use the  up or  down arrows to advance through the available set points until SSP displays on the screen and press the **ENTER** button.
- Use the  up or  down arrows to set the desired superheat displays on the screen and press and hold the **ENTER** button until SSP once again displays on the screen.
- Press the **BACK** to return to escape the settings menu.

5.7 EVAPORATOR CONDENSATE DRAIN TUBE



WARNING TO INSTALLER:

Evaporator Condensate Drain Tube may become dislodged during shipping. Installer must check Evaporator Condensate Drain Tube upon installation to be sure drain tube is properly seated and installed correctly.

Evaporator Drain Tube must be attached to tube protruding from bottom of Evaporator Tub and must either be inside the Condensate Pan area or inside of hole of Condensate Pump.

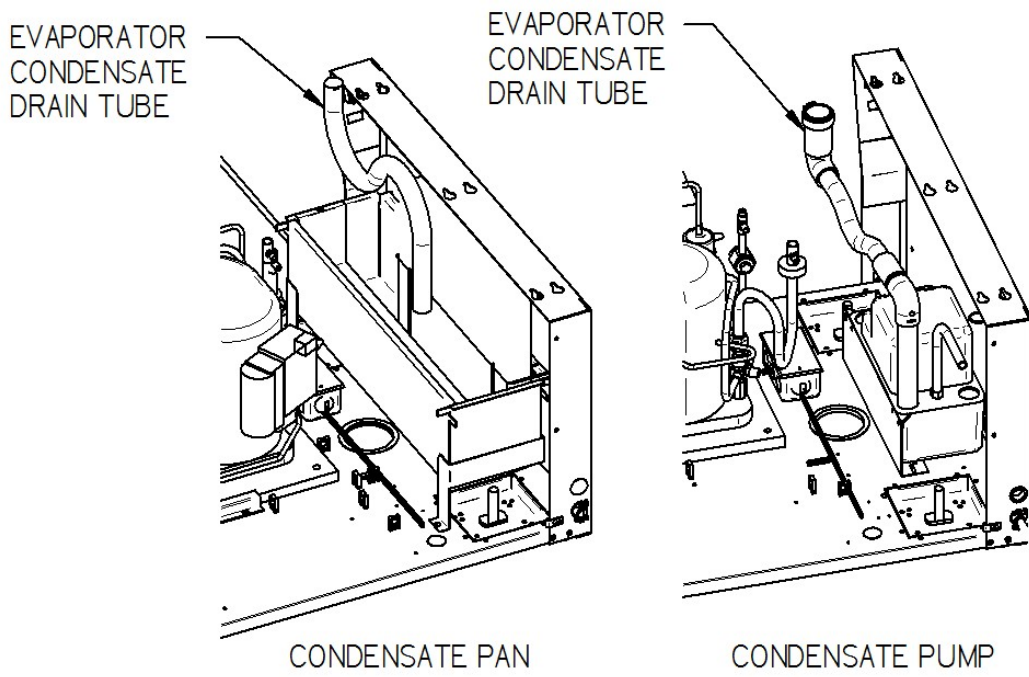

5.8 CONDENSATE PUMP

A condensate pump is Standard on some models and Optional on all models. Installer must check unit to see if a condensate pump has been provided with case.



WARNING TO INSTALLER:

Installer must determine if case was provided with condensate pump. Failure to hook up pump hose to drain will cause water on floor and cause a slip hazard.

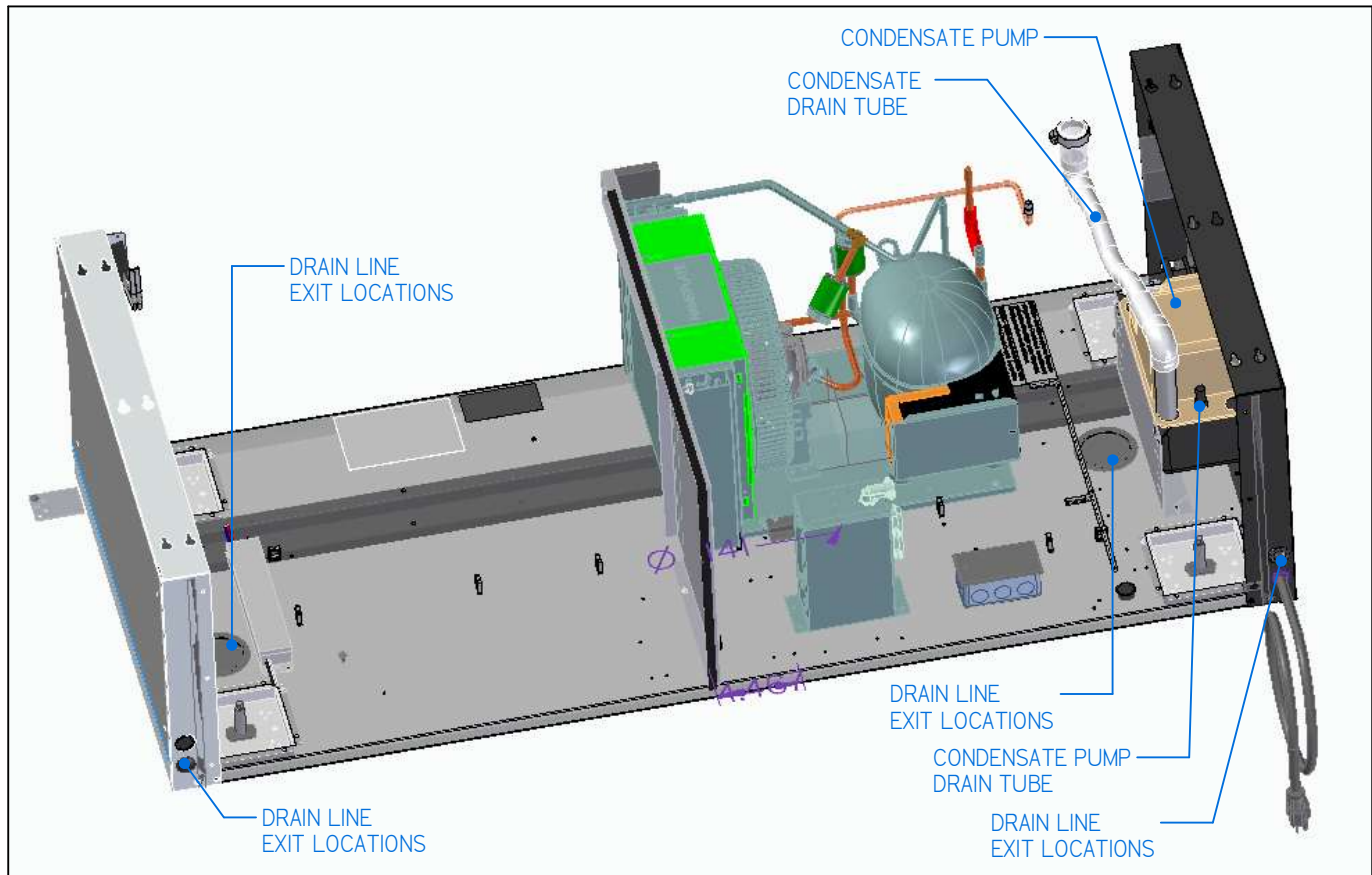

Instead of using heat energy to remove condensate run off from the evaporator coil a condensate pump moves the water to a nearby drain.

- The Condensate Pump is provided with 50ft of clear 1/2in OD x 3/8in ID tubing that must be run out of the base area to a drain.
- There are several drain tube exit locations provided in the base as noted in the drawing above. Plugs or caps will need to be removed in the desired exit location.
- The hose can be run the entire 50ft in any direction as required, but no higher than 20ft from the pump base. A check valve is provided in the pump to prevent water from flowing back into the reservoir. For best efficiency extend the hose level below the level of the pump base to create a siphoning effect. Never run the hose to or through an area below freezing (32°F, 0°C) or freezing water will block the tube.

(6) SHELVING INSTALLATION & REMOVAL

6.1 METAL SHELVES

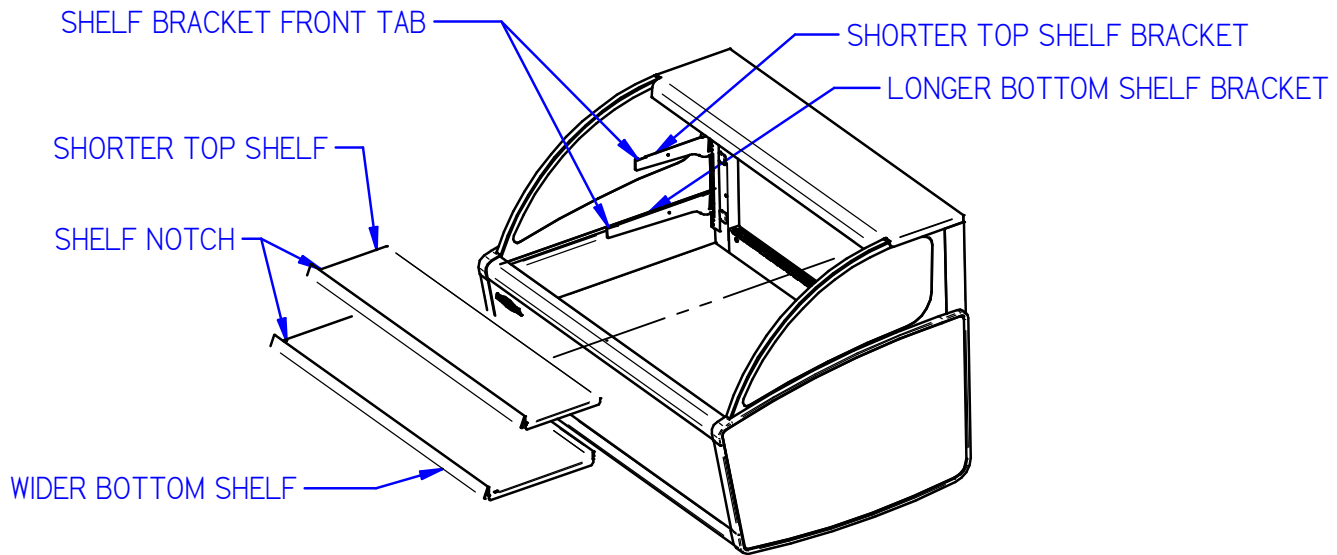

1. Follow the instructions in the illustration below and insert (1) of the shelf brackets in the desired shelf standard slot on one side of the case. Place the additional bracket in the same shelf standard slot on the opposite end of case. If the case was supplied with shelf light option (ELPRSS), the bracket with a clear plastic cord retainer clip must be on the side with the shelf light. For LPRSS case with (2) shelves repeat for shorter top shelf brackets.

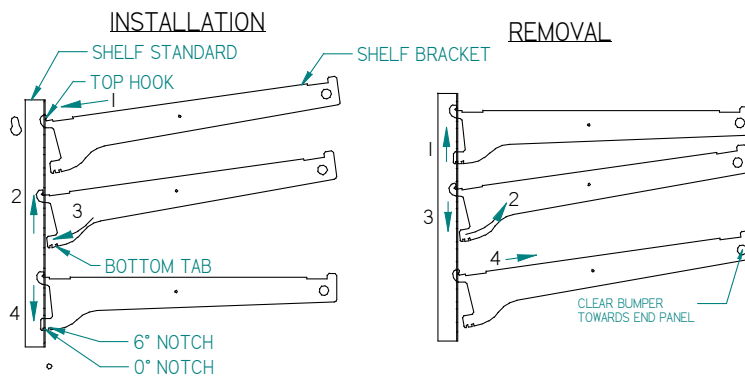

1. Place shelf bracket top hook into desired shelf standard slot.
 2. Lift shelf bracket top hook to allow shelf bracket bottom tab to clear shelf standard slot.
 3. Swing shelf bracket bottom tab into shelf standard slot.
 4. Place the desired shelf bracket notch of 0, 6, or 12 degrees onto bottom of shelf standard slot.
1. Lift shelf bracket up to allow shelf bracket notch to clear the bottom of shelf standard slot.
 2. Swing shelf bracket bottom tab out of shelf standard slot.
 3. Drop shelf bracket down to allow shelf bracket top hook to clear top of shelf standard slot.
 4. remove shelf bracket top from shelf standard slot.

2. Place the longer bottom shelf on top of the longer bottom shelf brackets with the flanges on each end of the shelf overhanging the outside of the bracket. Place the front tab of the shelf bracket into the notch located on the front of the shelf.

3. On the LPRSS case with (2) shelves place the shorter top shelf on top of the shorter top shelf brackets with the flanges on each end of the shelf overhanging the outside of the bracket. Place the front tab of the shelf bracket into the notch located on the front of the shelf.
4. If shelf includes optional light (ELPRSS), plug the cords into the plug receptacle located toward rear of case.

6.2 GLASS SHELVES

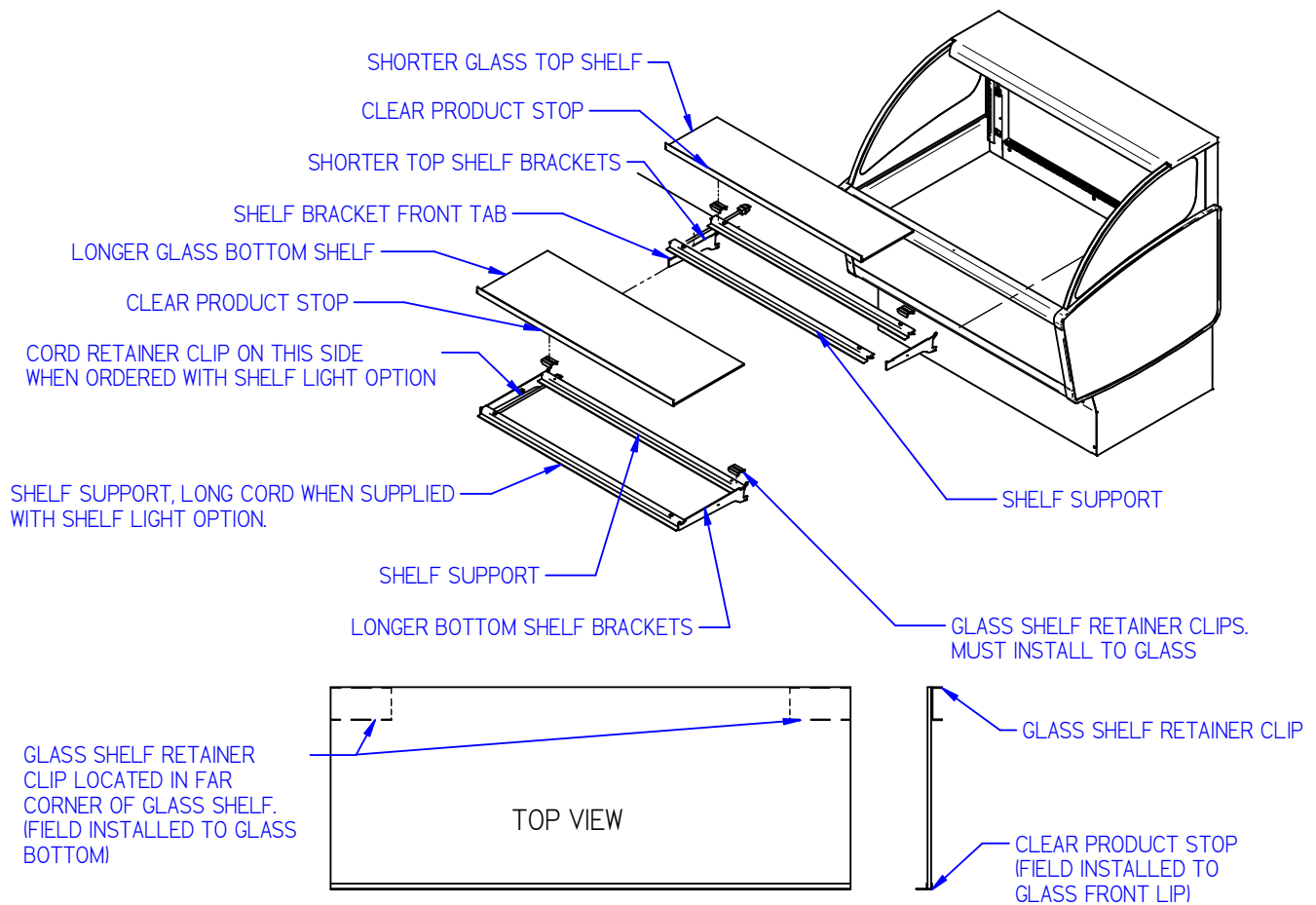

1. When installing for the first time, attach (2) glass shelf retainers to each glass shelf. Remove the backing from the tape located on the flat side of the glass shelf retainer. Position the glass shelf retainer in the (2) far corners of the glass as shown in the above figure. Repeat for each glass shelf.
NOTE: Clean the area of glass where the glass shelf holder is to be located with isopropyl alcohol and let it air dry before installing the glass shelf holder.
2. When installing for the first time attach (1) clear glass product stop to each glass shelf as shown in the figure above. Align the clear product stop edge with the edge of the glass and push the “U” portion of the glass product stop onto the glass lip across the entire front of the glass. Repeat for each glass shelf.
3. Install the shelf brackets into the shelf standard as described in Step (1) of “Metal Shelves Installation” of this manual.

4. Place the front of the glass shelf onto the front shelf support.
5. Set the rear side of the glass shelf onto the rear shelf support so that the glass shelf retainers straddle the rear shelf support.
6. Repeat steps 2 & 3 for each tier.

6.3 OPTIONAL SHELF LIGHTS - ELPRSS

1. Install shelves as described in the Metal Shelves Installation and Glass Shelves Installation sections in this manual. Note: On models with glass shelves with lights, a shelf support will be placed on the back and front of the shelf bracket.
2. Remove the cap from the appropriate female light sockets.
3. Plug in each shelf light by plugging the male plug on the appropriate shelf light cord plugs with the female light sockets and push together.

Shelves and shelf light quantity

It is not required that all shelves and shelf lights supplied with each case are used. The quantity of shelves and shelf lights can be tailored to your specific needs. If the supplied quantity of shelves and shelf lights are not required, cap unused female socket located in interior of the case mullion with caps supplied.

(7) PLASTIC END REMOVAL & INSTALLATION

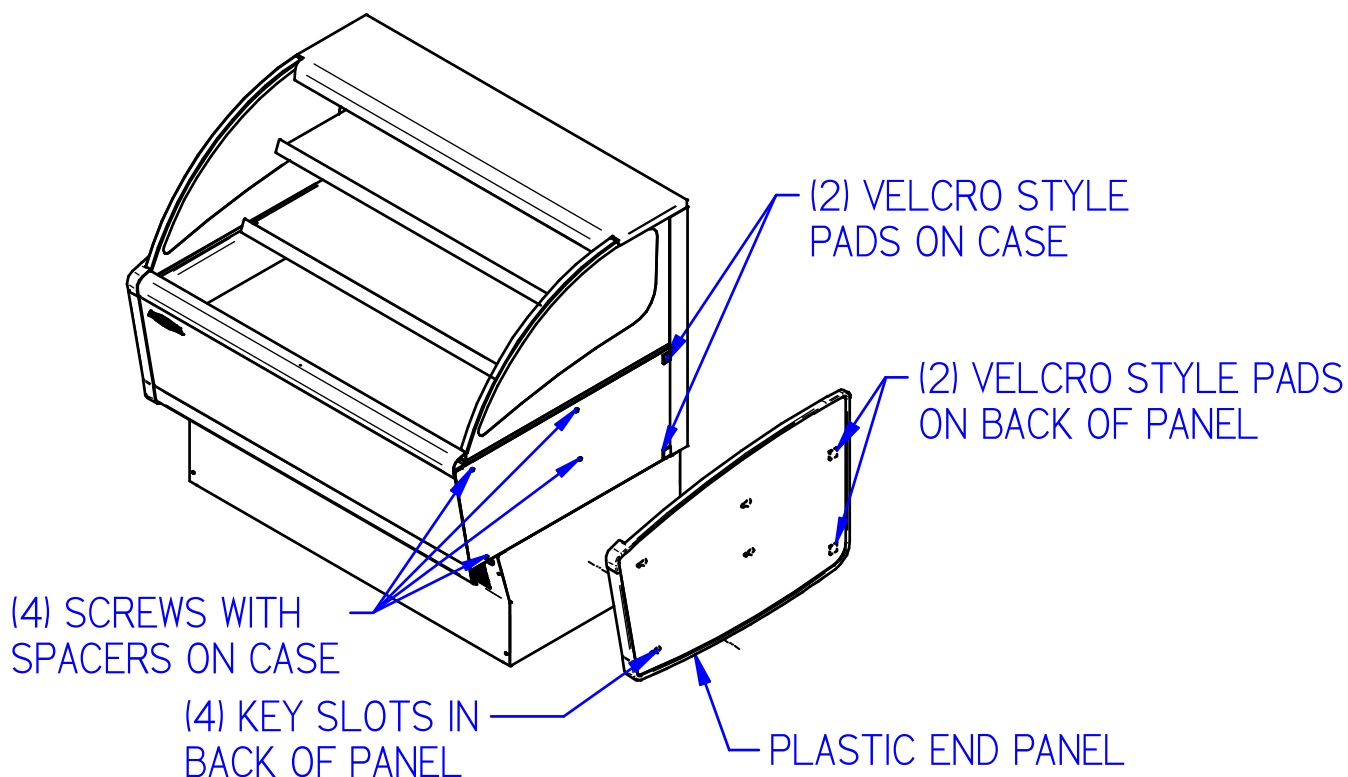

Right and Left plastic end panels are ordinarily shipped installed from the factory but can be easily removed for cleaning. Removing end panels make it easier to grab on to case when moving or installing case and can easily be reinstalled.

REMOVAL:

1. Lift the back side of the panel out to disengage (2) Velcro style pads
2. Slide the panel forward to disengage the (4) Key slots in panel from (4) screws in case.

INSTALLATION:

1. Hold panel tightly against the side of the case with the front lip of panel tight against front of case.
2. Slide panel forward about $\frac{1}{2}$ until screws fall into key slots. Slide the panel towards the back of case making sure all (4) key slots engage.
3. Push in on end panel in location of the (2) Velcro style pads to lock panel in place.

(8) REAR DOORS (OPTIONS)

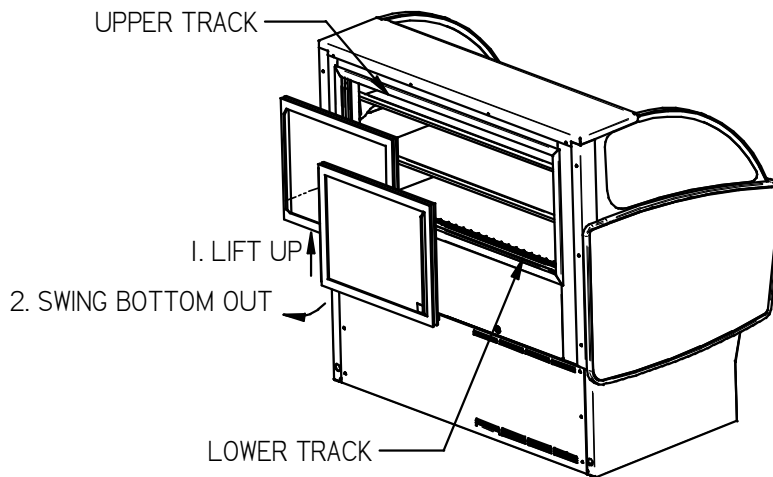

1. Start with the outer door and lift the door upward until the bottom edge of door clears the lower track and then swing the bottom of the door outward and down out of upper track.
2. After the outer door is removed repeat the procedure for the inner door.
3. Reverse this procedure for door reinstallation. The doors are not interchangeable.

(9) NIGHT CURTAIN

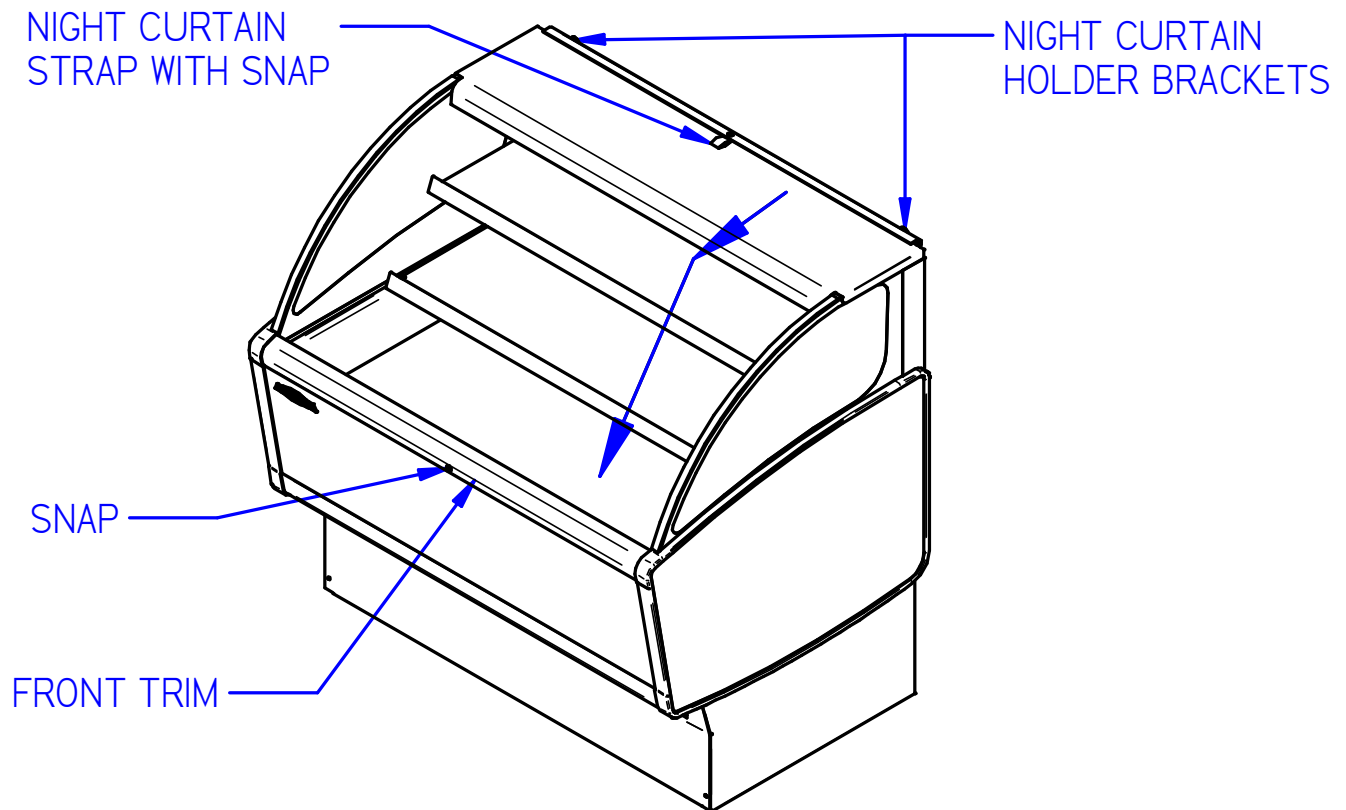

OPENING:

1. Grab night curtain strap and lift the rolled night curtain out of the night curtain holder brackets. Pull the night curtain across the top of case and down the front.
2. Attach the snap located under the night curtain strap on to the snap located on the front trim.

CLOSING:

1. Grab the night curtain strap and detach the snap from the snap located in the front top trim.
2. While holding the night curtain strap allow the night curtain to roll up and place the rolled night curtain carefully into the night curtain holder brackets.

Note: The 5' and 6' models have (2) night curtains.

(10) SECURITY NIGHT COVER (OPTION)

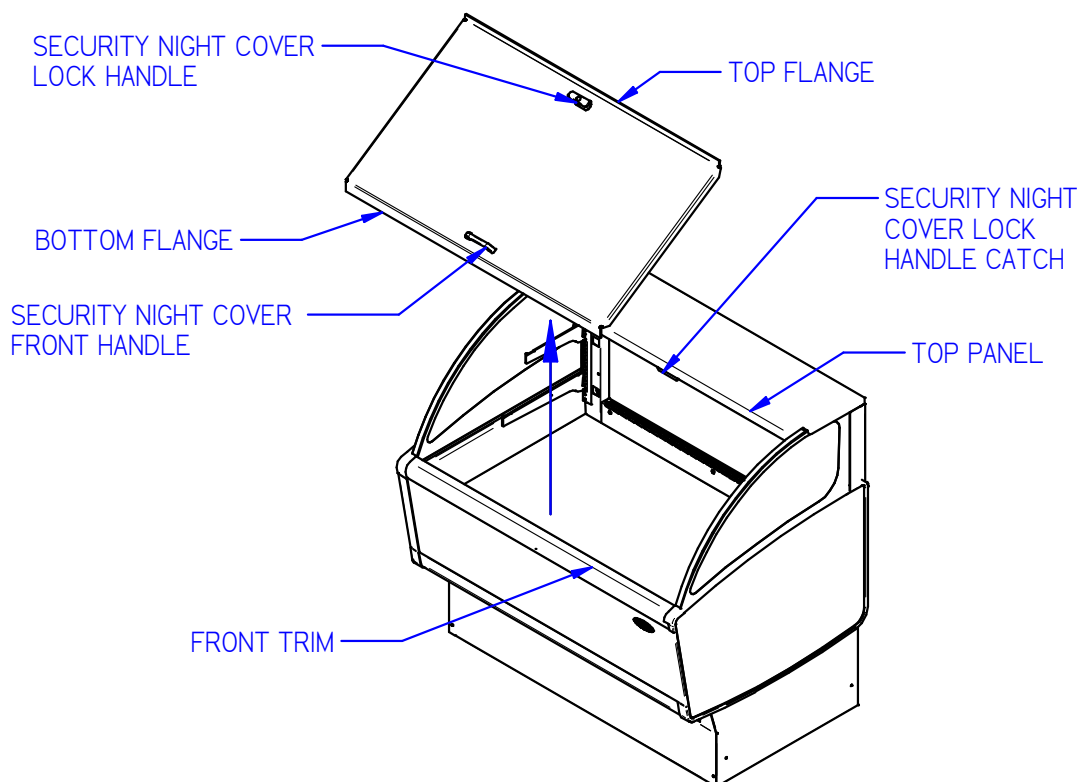

REMOVAL:

1. Unlock the lock handle and turn handle to disengage from lock handle catch.
2. Grab the lock handle and the front handle and lift the cover straight up out of the case opening.

INSTALLATION:

1. Turn the lock handle so the latch is horizontal to the top of the case.
2. Holding the lock handle and the front handle place the bottom flange of the security night cover inside of case opening. The bottom flange of the security night cover must be tight against the flat inner side of the front trim.
3. Set the top flange of the security cover down against the top panel.
4. Turn the lock handle so it engages the lock handle catch and use key to lock it in place.

Note: The 6' models have (2) security covers.

IMPORTANT: Cleaning the Acrylic plastic security night cover require special care to prevent hazing of material. Lightly dust (not wipe) the surface with clean soft cloth. Then the surface can be wiped carefully with a soft, wet cloth or chamois. The cloth or chamois must be kept free of grit by frequently rinsing in clean water. Grease and oil can be removed with kerosene. Do not use window cleaners or kitchen scouring compounds. DO NOT use solvents such as Acetone, Benzene, Carbon Tetrachloride, and Lacquer Thinners. A spray wax such as Pledge or Maguire's polish can be applied and wiped with a clean soft cloth. The wax tends to fill in and hide small scratches.

(11) OPERATING INSTRUCTIONS

11.1 USER CONTROLS OVERVIEW

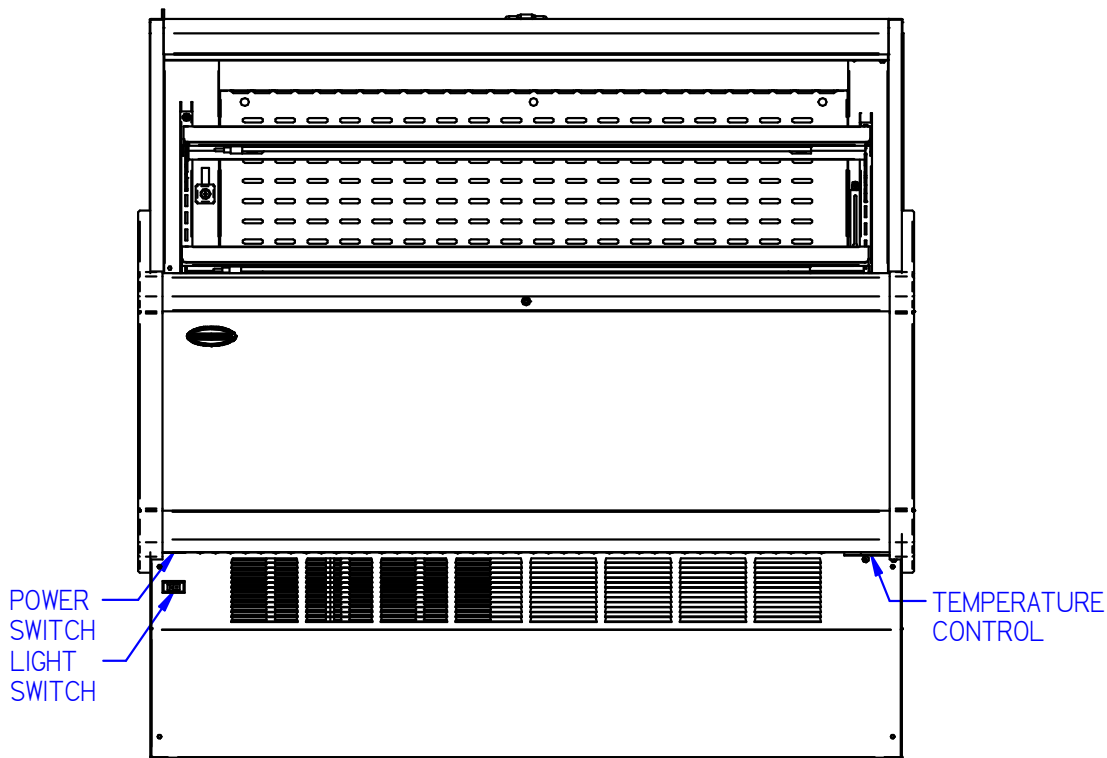

Power Switch

The unit has a power switch that turns off power to the entire unit, including the condensate evaporator and the lights. This switch is located behind the front valence on the unit base.

Light Switch

The unit has a light switch that turns on and off the interior lights of unit. The switch is located on the left hand side of the base front below the power switch.



Temperature Control

Located in the front grille of the display case, the temperature control allows the user to adjust the temperature of the display merchandiser to their needs.

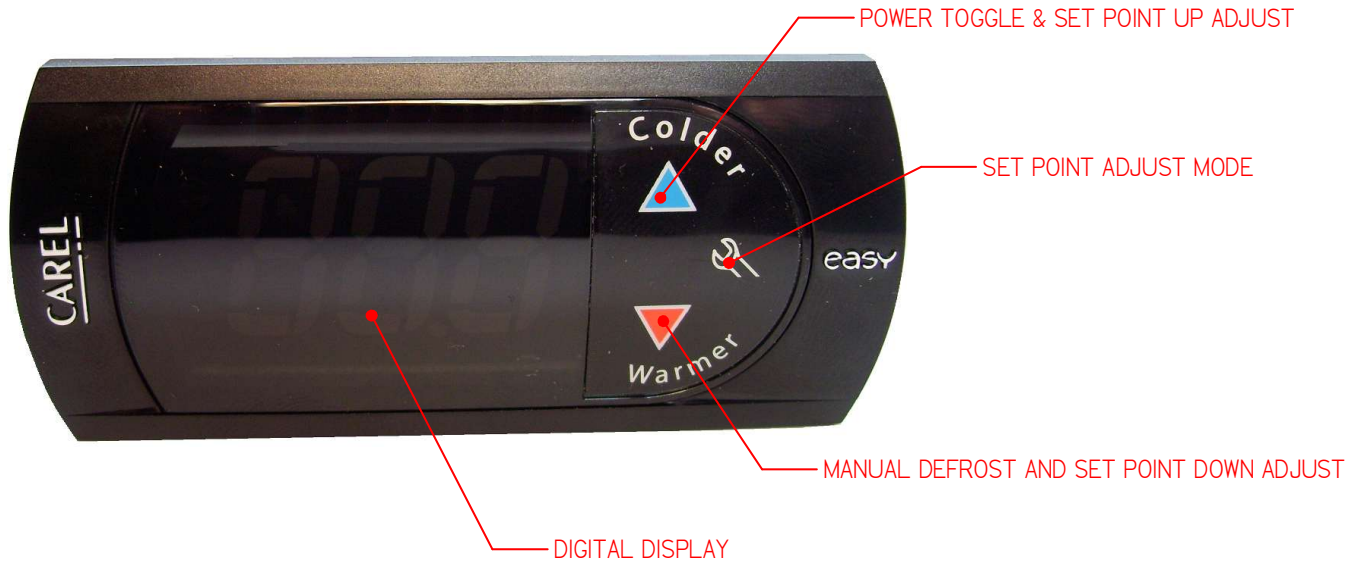
11.2 USING THE ELECTRONIC CONTROL

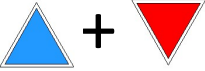

11.2.1 Button and Display Overview

	Press and hold this button for 3s to turn system on (if off) or off (if on). Also used to adjust set point when in set point adjust mode
	Press to enter set point adjust mode, confirm set point changes, and mute alarms.
	Press and hold this button for 3 seconds to initiate a manual defrost (and cancel defrost if initiated), also adjusts set point down when in set point adjust mode
	Press both buttons simultaneously to check air stream probe temperature. <i>This is not an indicator of product temperature.</i>

11.2.2 Powering on control

To turn power on to the refrigeration system press and hold, for three seconds, the blue up arrow on the control's keypad. The keypad will read "On" while the button is depressed. When the system powers on, the display will read the current set point (a number "1" through "9"). The orange compressor run indicator will illuminate on the display.



11.2.3 Adjusting the set point

The set point is what determines how cold the display case will hold food and beverage. To adjust the set point press and hold the wrench button until the display begins to flash a number (three seconds). Then use the up and down arrows of the keypad to scroll through the set point options. There are nine (9) available set points, the higher the number of the set point name, the colder the display case will run, with setting “9” being the coldest and setting “1” being the warmest. Once you have chosen your desired setting press the wrench button again to confirm your choice.



11.2.4 Entering manual defrost mode

In order to initiate a manual defrost press and hold the red down arrow for 3s. The control will read “DEF” while the button is being held. The defrost is initiated when the orange snowflake appears on the control display.



11.2.5 Error codes

It is possible for error codes to be displayed on the control screen. In the event of a malfunction an alarm will sound and a red ringing bell will be displayed on the screen. An error code or codes will flash intermittently on the display. If there are multiple codes, the display will continuously cycle through them. The following photo shows error code “E0” as an example next to the red bell.



You may mute the alarm by pressing and releasing the wrench button. The red ringing bell and all error codes will still be displayed. When the fault is remedied the control will return to normal operation and will automatically clear the codes from the display.

11.3 INITIAL STARTUP

After all the checks outlined in the installation section of this manual have been made, the case is ready to be put into service. Turn on the Power at the breaker box and flip the Power Switch and Light Switch on unit to the on position. Also ensure that the control is powered on as described above in “11.2.2”.

At start up from a warm unit, it is recommended that the temperature control is set to a warmer setting, such as 1. After the unit has gone through several cycles, adjust the control to a mid range setting, then to a colder setting if necessary to maintain desired product temperature

	NOTICE: This refrigerated display case is designed to operate in a maximum environment of 75°F (23.9°C) and 55% relative humidity. Exceeding these limits will cause poor case performance and excessive sweating.
--	--

11.4 PLACING PRODUCT IN CASE

- Do not exceed weight limits shown in the table below when loading product into the display case.

Table 2 - Shelf Loading Limits

Model	Top Shelf/ELPRSS Shelf	Bottom Shelf	Display Deck
E/LPRSS3	70lbs (32kg)	100lbs (45kg)	250lbs (114kg)
E/LPRSS4	100lbs (45kg)	135lbs (61kg)	320lbs (146kg)
E/LPRSS5	120lbs (55kg)	170lbs (77kg)	390lbs (177kg)
E/LPRSS6	150lbs (68kg)	210lbs (95kg)	460lbs (209kg)

- Determine desired shelving location before placing product in case. Product must be removed to readjust shelf location.
- Allow a minimum of 2 inches between top of product and bottom of shelf as shown below.

LEAVE 1/2" GAP BETWEEN PRODUCT TO ALLOW AIR FLOW AROUND PRODUCT

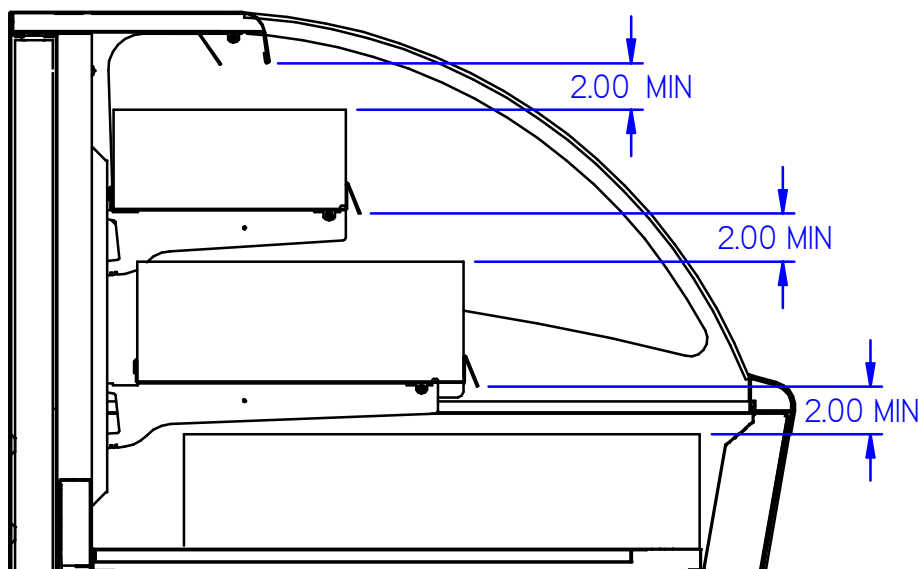

- Do not overhang the front or rear of shelves with product. Improper clearance in front and rear of shelf will block the refrigerated air flow and will cause product loss.
- Do not block the slots along the front and rear air discharge slots. Covering these slots will block the refrigerated air flow and will cause product loss.
- The display deck is removable for cleaning and can become dislodged in shipment. To ensure proper airflow and performance of the case, make sure that the display deck is pushed completely down.
- Allow refrigerated models to run for at least two hours before placing pre-chilled product into unit.



NOTICE:

Case must be stocked with pre-chilled product only. Product should be at or below 40°F (4.5°C) before adding it to the display case. Use a refrigerator to pull down product that is above 40°F (4.5°C). This display case is temperature holding product only it *will not* pull down product that is above the recommended temperature.

(12) MAINTENANCE

12.1 LIGHT REPLACEMENT

1. All lights are LED Bar type. The TOP LIGHT is attached to LIGHT LINER using plastic clips. SHELF LIGHTS are attached using double sided tape. If replacement should become necessary follow the directions below to replace LED light.

TOP LIGHT

- Unplug cord from light
- Carefully pry plastic clip tab away from lip on LED light body, with a slight twist motion, disengage the clip locking tab on each of the plastic clips. Install replacement LED by inserting replacement LED lip on the body under the locking tab on plastic clip.)
- Re-install cord plug.

SHELF LIGHTS

- Unplug cord from light
 - Use putty knife to pry LED light body from Shelf and or Top Light Liner. It may be useful to slide the putty knife along the length of light once putty knife is between LED light body and component surface. (it is recommended to remove shelves from case when replacing LED lights)
 - Remove residual adhesive tape from shelf / top light liner and clean surface with alcohol
 - Remove liner from Double Sided Tape on replacement Light
 - Use small holes in Top Light Liner & Shelves as a locational guide for LED placement
 - Mount light and apply pressure along the length of LED body to ensure good adhesion
- Re-install shelf and cord plug.

(13) PERIODIC MAINTENANCE

IMPORTANT: Read this Section of this manual located on page 7.
“REFRIGERATION WARNING & INSTALLATION-REPAIR-DECOMMISSIONING”
All refrigeration and electrical work must be performed by certified technicians.

13.1 CLEANING CONDENSER COIL

It is very important that the condenser coil is cleaned twice per month to insure proper refrigeration performance and to prevent compressor failure. Failure to clean condenser coil will void condenser warranty.

1. Disconnect power to the unit
2. Remove the front panel located on the front bottom of unit by removing the (4) front panel retaining screws.
3. Carefully vacuum the front surface of condenser coil. Take care not to bend coil fins with vacuum cleaner nozzle, a brush attachment works well to prevent this.
4. Reinstall front panel and retaining screws.

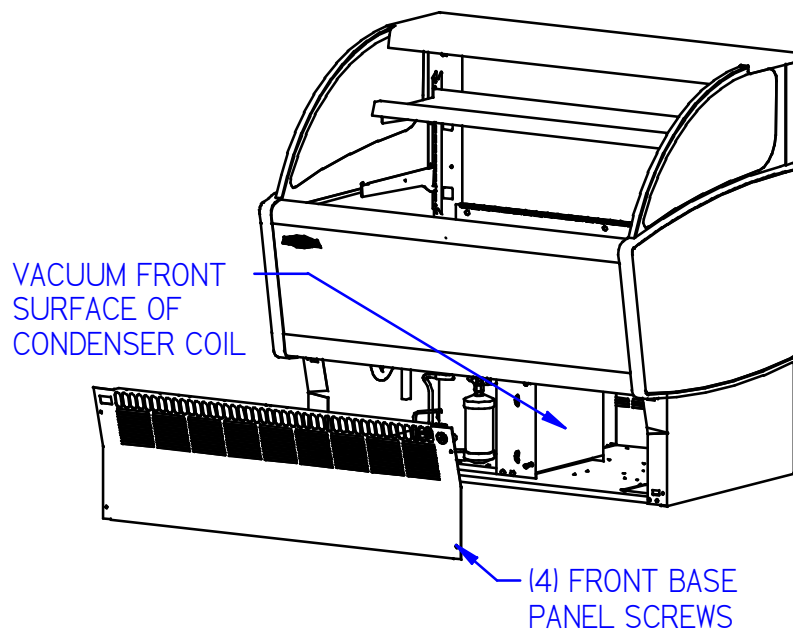







Figure 1 - Condenser Cleaning

(14) CLEANING INSTRUCTIONS

14.1 DAILY CLEANING

The case should be cleaned thoroughly, as described in the weekly cleaning section, before it is used for the first time.



	NOTICE: Avoid splashing or soaking any electrical components with water to prevent electrical damage to the case.
	NOTICE: Shut off lights and power switches and remove all product from case. Allow sufficient time for the unit to reach room temperature before proceeding with cleaning.
	NOTICE: Remove all product from case before proceeding with cleaning procedure.
	NOTICE: Acrylic end panels and top panel require special washing procedures to prevent hazing and yellowing of material. Read cleaning of end panel and top panel procedure carefully.
	NOTICE: This case is not designed to be cleaned by flushing.

Note: For major spills or foreign material buildup perform the weekly cleaning instructions.

1. (If Supplied With Optional Rear Doors.) Clean all foreign materials from the door opening and clean both sides of the doors with a damp cloth
2. Wipe complete interior and exterior of case using a damp cloth.
3. Clean both sides of end glass panels using any common window cleaner.

14.2 WEEKLY CLEANING

This procedure is recommended on a weekly basis. It may need to be performed more often if necessary to maintain a clean, sanitary case. The case should be cleaned to this procedure before using the first time.

	NOTICE: Avoid splashing or soaking any electrical components with water to prevent electrical damage to the case.
	NOTICE: Shut off lights and power switches and remove all product from case. Allow sufficient time for the unit to reach room temperature before proceeding with cleaning.

**NOTICE:**

Remove all product from case before proceeding with cleaning procedure.

**NOTICE:**

This case is not designed to be cleaned by flushing.

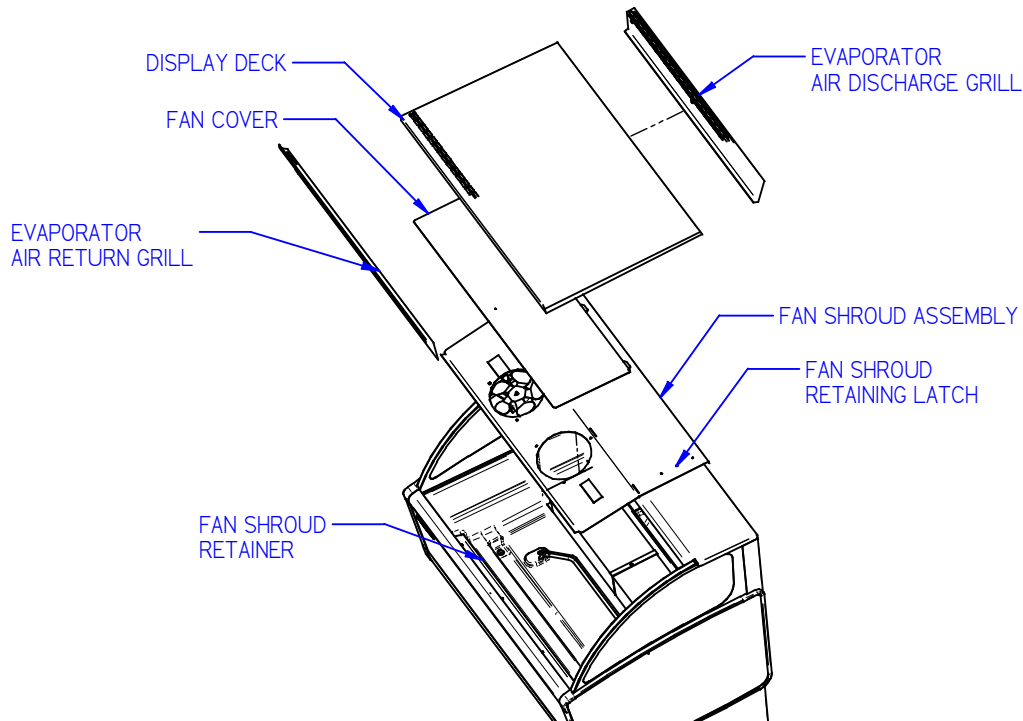

1. If supplied with rear door option remove both rear doors as described in the “Door Removal” section of this manual.
2. Remove shelving from unit as described in the “Shelving Installation and Removal” section of this manual. Remove all interior shelving as described in the shelving installation and removal section of this manual.
3. Remove both shelf standards from interior of case by removing the (2) thumbscrew from top and bottom.
4. Lift the display deck up and out of evaporator tub.
5. Lift the grab tab of the fan cover and slide the fan cover tabs out of the fan shroud assembly slots. and.
6. Remove the fan shroud assembly by lifting (4) black tabs up on each end of evaporator coil. Lift the rear of the evaporator fan shroud and slide the front lip out of the fan shroud retainer. Reach in and unplug the evaporator fan motor cord. Remove evaporator fan shroud.

7. Clean the entire interior of the case using warm soapy water. Wipe off all soapy water with a damp cloth and allow to dry. (DO NOT use solvents such as Acetone, Benzene, Carbon Tetrachloride, and Lacquer Thinners)

NOTE: Depending on the amount of usage and spillage of foreign material, some fasteners may have to be removed and parts disassembled to allow proper cleaning of the unit.

8. Clean all shelves, shelf support bars, shelf brackets, and display pans using warm soapy water and a brush. Rinse thoroughly and allow to dry.
9. If supplied with rear door option clean all foreign material from inner and outer rear door tracks and clean them and both sides of the doors using warm soapy water and a brush. Apply a light film of lubricant such as PAM to door tracks to make the doors operate smoother.
10. Clean end glass panels using any common window cleaner.
11. Reassemble the case in reverse order.

(15) SALES & DISPOSAL

IMPORTANT: Read this Section of this manual located on page 7.
“REFRIGERATION WARNING & INSTALLATION-REPAIR-DECOMMISSIONING”
All refrigeration and electrical work must be performed by certified technicians

If you, the owner, sells or gives away this Federal Industries case, it is the owner’s responsibility to make sure that all safety labels and the Installation-Service Manual are included with it. If you need replacement labels or manuals, Federal Industries will provide them free of charge. Contact the customer service department at Federal Industries at (800) 356-4206.

The customer service department at Federal Industries should be contacted at the time of sale or disposal of your case so records may be kept of its new location.

If you sell or give away your Federal Industries case, you should evacuate the refrigerant charge before shipment. Federal Industries recommends that the charge be evacuated into a recovery system to prevent the possibility of HFO’s from being released into the atmosphere.

Refrigerant Recovery/Recycling/Disposal

When recycling or discarding case, refrigerants **MUST BE** handled according to local, state and federal codes, requirements and regulations.

If disposing of a refrigerated case that uses ozone depleting chemicals in its refrigeration system, make sure the refrigerant is removed by a qualified service technician and properly disposed of.

If you intentionally release refrigerant into the atmosphere, you may be subject to fines or other penalties (under regulation mandated by environmental regulators and/or legislative edict.)

15.1 OWNER RESPONSIBILITY

If you sell or give away your Federal Industries case, you must make sure that all safety labels and the Installation-Service Manual are included with it. If you need replacement labels or manuals, Federal Industries will provide them free of charge. Contact the customer service department at Federal Industries at (800) 356-4206.

The customer service department at Federal Industries should be contacted at the time of sale or disposal of your case so records may be kept of its new location.

If you sell or give away your Federal Industries case and you evacuate the refrigerant charge before shipment. Federal Industries recommends that the charge be evacuated into a recovery system to

(16) SERVICE INFORMATION

Fax: (608) 424-3234 Service Information

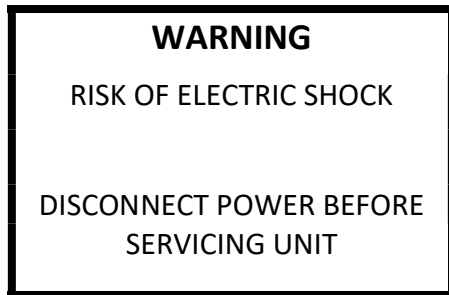

Before any service work is performed on the case, make sure all power is disconnected to the case.

IMPORTANT: Read this Section of this manual located on page 8 “REFRIGERATION WARNING & INSTALLATION-REPAIR-DECOMMISSIONING” All refrigeration and electrical work must be performed by certified technicians.

To find a service company in your area, please visit our website at <https://federalind.com/support-service/service-rep-locator>. There you can also find self-service tools to help you get the answers you need faster!

For warranty service requests and all technical support, including compressors and other service parts please contact:

- Phone: (833) 238-8168
- Email: techservice@partstown.com



Federal Industries has partnered with Parts Town for ALL Non-Warranty Part Identification, Pricing, Lead Times, Orders & Freight Quotes. Please contact Parts Town directly if you need parts:

- Website: Partstown.com
- Email: CustomerService@Partstown.com
- Phone: 833-809-8188

16.1 PRE-SERVICE CHECKLIST

You may avoid the cost and inconvenience of an unnecessary service call by first reviewing this checklist of frequently encountered situations that can cause unsatisfactory case performance.

	CAUTION: Before servicing case, turn off power at the main breaker of fuse box.
---	--

16.1.1 Case does not operate

- Check for disconnected power supply.
- Check for tripped breaker or blown fuse.
- Check that power switch is on.

16.1.2 Lights do not operate

- Check that light switch is on.
- Shelf light: Check that shelf light cords are tight in the sockets

16.1.3 Case temperature too warm (product is exceeding 41°F)

- Check that the cold air inlet and outlet slots are not blocked.
- If supplied with rear door option be sure that the rear doors are closed and tightly sealed

Check for blocked or dirty condenser coil fins and clean them (see “0 **IMPORTANT:** Read this Section of this manual located on page 7.

“REFRIGERATION WARNING &INSTALLATION-REPAIR-DECOMMISSIONING”

All refrigeration and electrical work must be performed by certified technicians.

- Cleaning Condenser Coil” page 33).

16.2 SPECIAL SERVICE INSTRUCTIONS

IMPORTANT: Read this Section of this manual located on page 7.

“REFRIGERATION WARNING &INSTALLATION-REPAIR-DECOMMISSIONING”

All refrigeration and electrical work must be performed by certified technicians

There are rare occasions when the refrigerant charge must be evacuated from a case in order to perform service work. In those situations, Federal Industries recommends that the refrigerant charge be evacuated into a recovery system to prevent the possibility of hydrofluorocarbons (HFC’s) from being released into the atmosphere.

If moisture or liquid is observed around or under a Federal Industries case, an immediate investigation should be made by qualified personnel to determine the source of the moisture or liquid. The investigation made should determine if the case is malfunctioning or if there is a simple housekeeping problem.

Moisture or liquid around or under a case is a potential slip/fall hazard for persons walking by or working in the general area of the case. Any case malfunction or housekeeping problem that creates a slip/fall hazard around or under a case should be corrected immediately.

16.3 ELECTRONIC CONTROL OPERATION

This unit is equipped with an electronic temperature control. The control parameters are set at the factory and cannot be manually changed in the field. The preset control parameters are listed on the chart in the Settings Chart below.

16.3.1 Operation

The control uses two sensors, one located in the air stream and one located on the evaporator coil. The sensor located in the air stream is referred to as the temperature control sensor. The sensor located on the evaporator coil is referred to as the defrost probe.

The temperature control sensor is located on the plastic tub behind the evaporator coil on the centerline of the display case in the cold air stream. The sensor location is critical for proper operation on the unit. Do not move or relocate this sensor.

The coil sensor is strapped to the evaporator coil. This sensor location is critical for proper operation of the unit. Do not move or relocate this sensor.

The temperature control is set to cut in at 38°F (3.3°C). The Temp control cuts out at 16°F (-8.9°C) at the coldest setting ("9") and 28°F (-2.2°C) at the warmest setting ("1").

See "11.2 Using the electronic control" on page 29 for more details on using the control.

16.3.2 Defrost Cycle

The control is programmed to initiate defrost via two different methods. There are 3 programmed defrost cycles in the case which will initiate a defrost cycle every 8 hours. The unit does not have a time clock so the defrost cycles cannot be set for any specific time of day.

The unit also has an 'On demand' defrost feature that will initiate a defrost when the temperature differential between the evaporator temperature and the air temperature is more than 12°F (6.7°C) for 5 minutes after 30 minutes into the refrigeration cycle (e.g. if the air stream probe measures 32°F/0°C or greater and the defrost probe measures 20°F/-6.7°C or lower for five minutes). Once initiated the defrost cycle will terminate when evaporator coil sensor reaches 45°F (7.2°C).

If a manual defrost is required, one can be initiated by pressing and holding the down arrow for three (3) seconds. This is typically unnecessary and should only be performed if special circumstances require it.

16.4 ERROR CODES

Error codes may be encountered if either the controller or the display case is malfunctioning. The following is a list of error codes that may be encountered.

Table 3 - Error Codes and Resolutions

Code	Description	Cause	Resolution
E0	Temperature probe error	Probe signal is interrupted or short-circuited	<ol style="list-style-type: none"> 1. Check to ensure probe wires and quick disconnect are secure in control. 2. Check probe resistance to table below. If 0 resistance is present, check wiring insulation. If infinite resistance is present, check for breaks in wiring (meter will likely read overload or very high in the mega-ohm range). 3. Ensure that probes are wired per the wiring diagram provided. 4. Replace probe if other remedies fail, or if probe resistance deviates from “Error! Reference source not found.” Error! Reference source not found.
E1	Defrost probe error	See E0	
EE	Unit parameter reading error	Operating conditions	<ol style="list-style-type: none"> 1. Remedy abnormal operating conditions. The control is rated to operate in a range of 14 to 122°F (-10 to 50°C) and less than 90%RH non-condensing. 2. Replace control if problem persists.
EF	Operating parameter reading error	See EE	

Table 4 - Temperature Probe Common Resistance Chart

Probe Temp	Maximum Resistance [Ω]	Normal Resistance [Ω]	Minimum Resistance [Ω]
32°F (0°C)	27.83	27.28	26.74
77°F (25°C)	10.1	10	9.9
212°F (100°C)	1	0.97	0.94

16.5 REFRIGERATION OPERATION

16.5.1 Self-Contained Models

The self-contained models are shipped from the factory with a completely operational refrigeration system and require no modifications or adjustments upon installation. Case must be installed as per the installation section of this manual to provide proper condensing air cooling.

The unit temperature is controlled by the electronic control outlined in the control section of this manual.

Note: The condenser fan runs continuously.

16.5.2 Remote Models

Refrigeration Charge R404a before 1/19, R449a after 1/19	CHARGED IN FIELD
Remote Low Press. Switch Cut In	50 psi
Remote Low Press. Switch Cut Out	15 psi
Adjustable Headmaster	200 psi
Remote High Press. Switch Cut Out	400 psi

The remote models are shipped from the factory with the evaporator coil, expansion valve, sight glass, and refrigerant solenoid valve. Filter Drier must be installed in field. Electronic control runs identical to the self-contained models except the electronic control opens and closes a refrigeration solenoid valve located on the suction line instead of turning on and off a compressor. The solenoid valve closes and shuts off the refrigeration flow to the unit and initiates a pump down cycle. This will allow the remote low pressure switch to open and shut off remote compressor.

The condensing unit and pressure controls are optionally supplied from the factory for remote location installation. The condensing unit must be mounted and wired by the installer. The high low pressure switch must be wired in series with the compressor power supply as shown in diagram below

1. Mount condensing unit indoors as close to the remote display case as practical. The refrigeration line should be as short as possible and must not exceed 30 feet.
2. All refrigeration and/or electrical materials between the condensing unit and display case are to be supplied by installing contractor.
3. Route properly sized and designed refrigeration lines from the condensing unit to the cabinet.
4. Horizontal suction lines should be pitched downward towards the condensing unit at least $\frac{1}{2}$ " per 10' run to aid the oil drainage. A "P" trap must be installed in the suction line at the foot of every riser to insure oil return. Dry nitrogen must be used to flow through tubing while brazing refrigeration lines.
5. Suction line must be insulated the entire length with Armaflex (or equivalent). Do not run liquid line inside insulation with suction line.
6. The remote high/low-pressure control must be mounted, wired and set pressures by the installer.
7. Leak check condensing unit, cabinet, and all connecting tubing. Cabinet and condensing unit tubing should be checked to ensure no leaks occurred during shipping or from rough handling.
8. Make certain all refrigeration valves are opened and evacuate system to 500 microns. Charge the system with refrigerant type specified on the data plates.

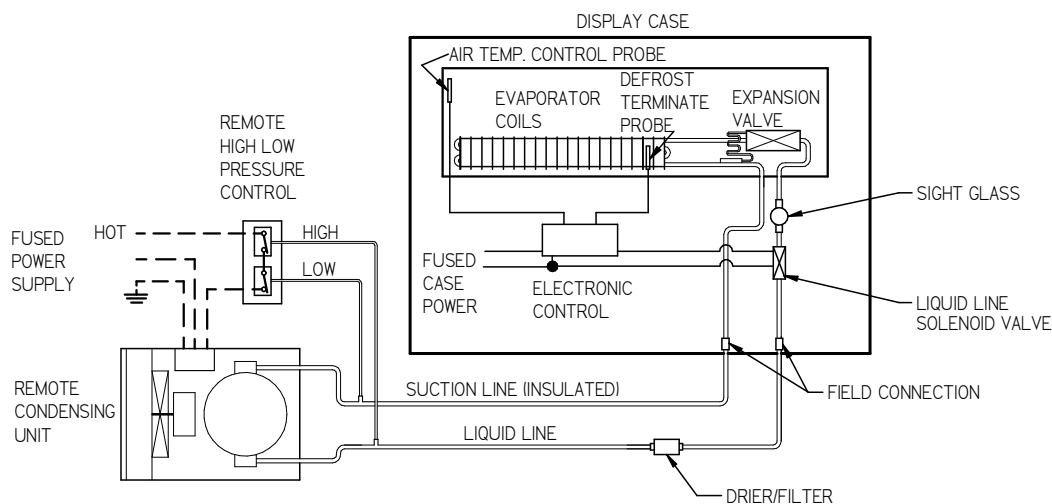
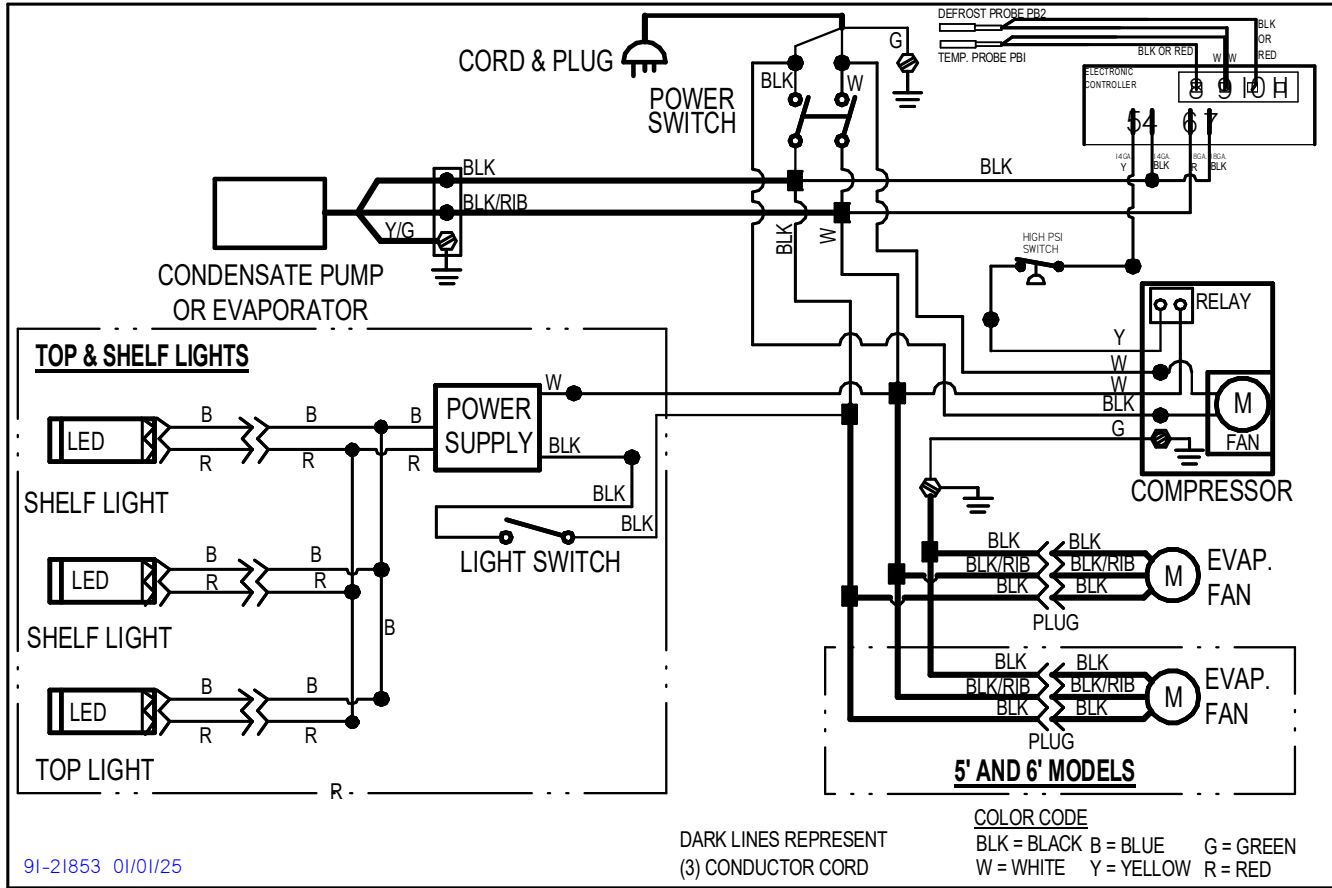

Figure 2 - Remote Refrigeration Diagram

(17) WIRING DIAGRAMS

17.1 SELF CONTAINED



17.2 REMOTE

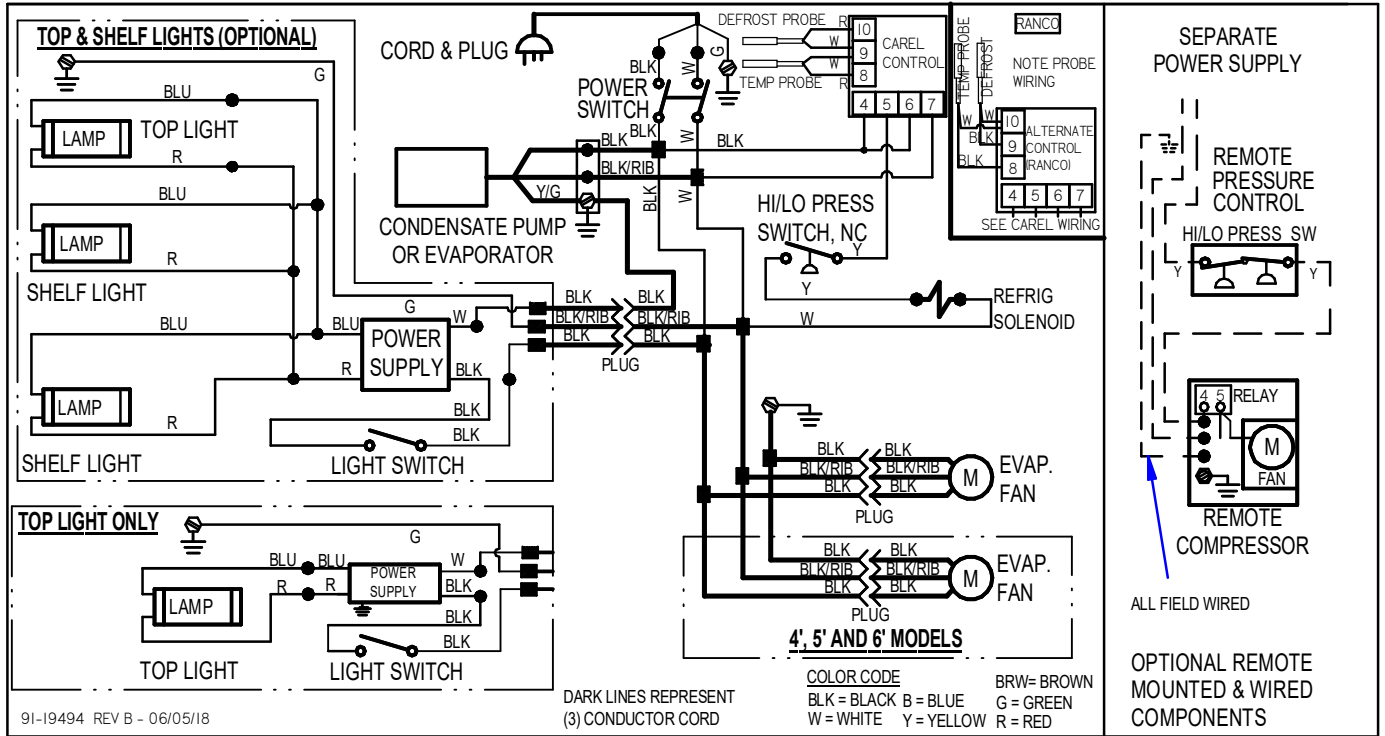

(18) REPLACEMENT PARTS

REFRIGERATION	LPRSS3, ELPRSS3 120V	LPRSS4, ELPRSS4 120V	LPRSS5, ELPRSS5 240V	LPRSS6, ELPRSS6 240V
Condensing Unit (Self Contained)	30-21725	30-21725	30-21762	30-21762
Evaporator Coil	33-17700-21	33-17700-22	33-17700-23	33-17700-24
TXV Expansion Valve	32-21751		32-21749	
High Pressure switch	32-21850			
Temperature Control	32-19445			
Temperature Probe	32-19094			
Control Display	32-19446			
Digital Display Ribbon Cable	32-19093			
Evaporator Fan	41-21237-16			
Latch Evaporator Housing to Coil	66-13640			
Condnsate Pump (Std 5 & 6)	47-15686		47-15687	
Condensate Base Fan Motor(Opt on Rem)	41-11628			
Condensate Base Fan Blade(Opt on Rem)	72-32507			
Condensate Pan Ass'y (Std 3 & 4)	SA5202		-	
Condensate Pan PTC Heater	40-19498		-	
Condensate Drain Tube	06-17699		SA5210	
Thermometer	32-13662			
ELECTRICAL	LPRSS3, ELPRSS3 120V	LPRSS4, ELPRSS4 120V	LPRSS5, ELPRSS5 240V	LPRSS6, ELPRSS6 240V
Light Switch	41-11066			
Power Switch	41-18186			
LED Light Power Supply	39-20986		39-20986	
Top Light Cord	43-20860-1B		43-20860-1B	
LED Light	42-20871-25C35	42-20871-38C35	42-20871-48C35	42-20871-66C35
Harness Led Lights	43-20974-1			
Top Shelf Light Cord (ELPRSS Optional)	43-20862-1B			
Bottom Shelf Light Cord (LPRSS)	43-20862-2B			
Main Wire Harness	43-19492			
Power Cord	43-11302		43-17839	
Wiring Diagram	91-21853 SC / 91-19494 REM			



LPRSS PANELS	LPRSS3	LPRSS4	LPRSS5	LPRSS6
Glass End Clear	50-17701			
Glass End Reflective Left(Optional)	50-17701-1L			
Glass End Reflective Right(Optional)	50-17701-1R			
End Panel Mirror Int.Left(Optional)	SA4287-L			
End Panel Mirror Int.Right(Optional)	SA4287-R			
Cover Top Black	M15910-1	M15910-2	M15910-3	M15910-4
Cover Top Stainless (Optional)	M15910-1A	M15910-2A	M15910-3A	M15910-4A
End Glass Trim Front Black	M15959			
EndGlass Trim Stainless (Optional)	M15959-A			
End Panel Ass'y Left (color needed)	SA4361-L			
End Panel Ass'y Right (color needed)	SA4361-R			
Pad 1x1 End Panel (Dual Lock 250)	77-17849			
Pad 1x1 Cabinet (Dual Lock 170)	77-17848			
ELPRSS PANELS	ELPRSS3	ELPRSS4	ELPRSS5	ELPRSS6
Acrylic End Clear	15-19808			
LPRSS SHELVING	LPRSS3	LPRSS4	LPRSS5	LPRSS6
Shelf Top Black	M20969-1	M20969-3	M20969-5	M20969-7
Shelf Bottom Black	M20969-2	M20969-4	M20969-6	M20969-8
Shelf Top Stainless (Optional)	M20969-1A	M20969-3A	M20969-5A	M20969-7A
Shelf Bottom Stainless (Optional)	M20969-2A	M20969-4A	M20969-6A	M20969-8A
Glass Shelf Top (Optional)	52-17991-1	52-17991-2	52-17991-3	52-17991-4
Glass Shelf Bottom (Optional)	52-17992-1	52-17992-2	52-17992-3	52-17992-4
Glass Shelf Retainer(Optional)	SA4091			
Shelf Bracket Top	67-17732-1			
Shelf Bracket Bottom	67-17732-2			
Shelf Standard	M14679-A			
ELPRSS SHELVING	ELPRSS3	ELPRSS4	ELPRSS5	ELPRSS6
Shelf Black	M20969-9	M20969-10	M20969-11	M20969-12
Shelf Bracket	67-17732-2			
Shelf Standard	M14679-A			
LPRSS MISCELLANEOUS OPTIONS	LPRSS3	LPRSS4	LPRSS5	LPRSS6
Rear Door Inner Black(Optional)	53-17912-1	53-17912-2	53-17912-3	53-17912-4
Rear Door Outer Black (Optional)	53-17913-1	53-17913-2	53-17913-1	53-17913-1
Rear Door Top Track (Optional)	57-17910-1	57-17910-2	57-17910-3	57-17910-4
Rear Door Bottom Track (Optional)	57-17909-1	57-17909-2	57-17909-3	57-17909-4
Rear Door Jamb (Optional)	57-17911			
Inner Rear Door LH	M22314-1L	M22314-2L	M22314-3L	M22314-4L
Inner Rear Door RH	M22314-1R	M22314-2R	M22314-3R	M22314-4R
Inner Rear Door Track Top & Bottom	M22308-1	M22308-2	M22308-3	M22308-4
Inner Rear Door Glides	W11939-1	W11939-2	W11939-3	W11939-4
Bracket, Door Closure	M22333	M22333	M22333	M22333
Security Night Cover Panel (Optional)	M16107-1	M16107-2	M16107-3	M16107-4
Security Night Cover Latch (Optional)	66-11727			
Night Curtain Black	65-19459	65-19460	65-19458	65-19300
Step Riser Top (Optional)	SA4367-1	SA4367-2	SA4367-3	SA4367-4
Step Riser Bottom (Optional)	SA4367-5	SA4367-6	SA4367-7	SA4367-8

California Residents Only.

 **WARNING**

This product can expose you to chemicals including chromium which is known to the State of California to cause cancer and birth defects or other reproductive harm. For more information go to www.P65Warnings.ca.gov

