

Mobile Soak Sink

ASSEMBLY INSTRUCTIONS

CAUTION

INSPECT CONTENTS IMMEDIATELY AND FILE CLAIM WITH DELIVERING CARRIER FOR ANY DAMAGE.

SAVE YOUR BOX AND ALL PACKING MATERIALS.

YOU ARE RESPONSIBLE FOR DAMAGE TO YOUR UNIT IF RETURNED IMPROPERLY PACKED.

This package contains:

- | | | |
|------------------------|-------------------------------|---------------------------------|
| (1) Sink bowl | (2) Front-to-back crossbraces | (1) Silverware chute (optional) |
| (4) Legs | (1) Left-to-right crossbrace | - (1) Chute |
| (2) End castings | (14) Set screws | - (2) Support brackets |
| (2) Corner castings | (1) Lever drain | - (4) Lock nuts |
| (2) Swivel casters | (1) Drain tail-piece | - (4) Wing nuts |
| (2) Casters with brake | (1) Scrap basket (optional) | |

Tool required:

- 5/32" allen wrench (supplied)
- adjustable wrench

Step 1 - Assemble crossbrace subassembly.

- Assemble corner and end castings to rear knockdown tube and front-to-back crossbracing.
- Snug the set screws* in the appropriate threaded hole in castings (see below).

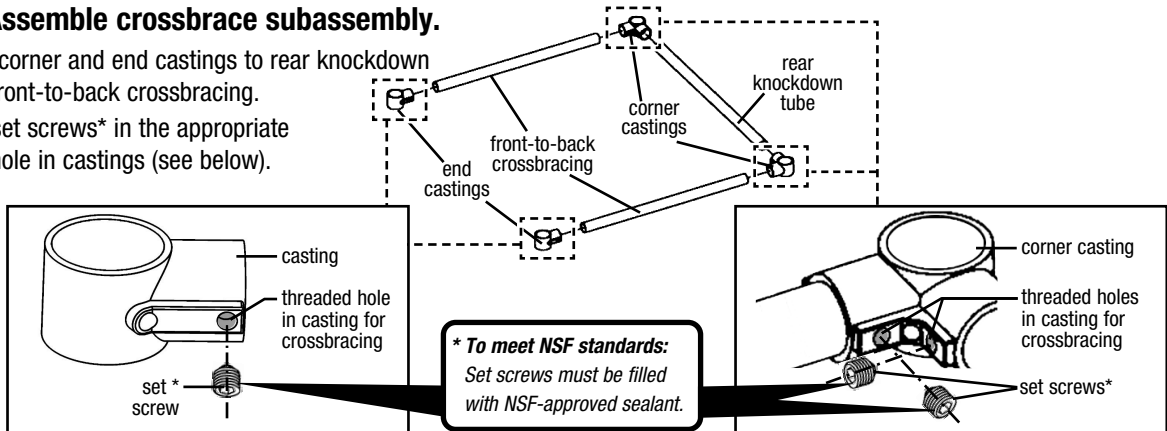

Step 2 - Attach crossbrace subassembly to legs.

- On legs, measure and mark desired height of crossbrace subassembly.
- Insert legs.
- Snug the set screws*.

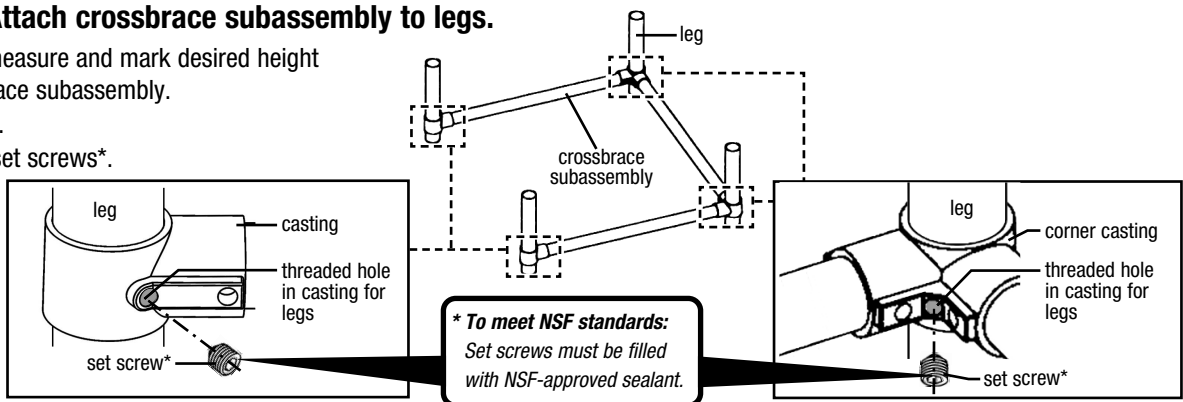

Step 3 - Attach sink bowl.

- Insert top of each leg into each gusset.
- Tighten all set screws*.

*** To meet NSF standards:**
Set screws must be filled
with NSF-approved sealant.

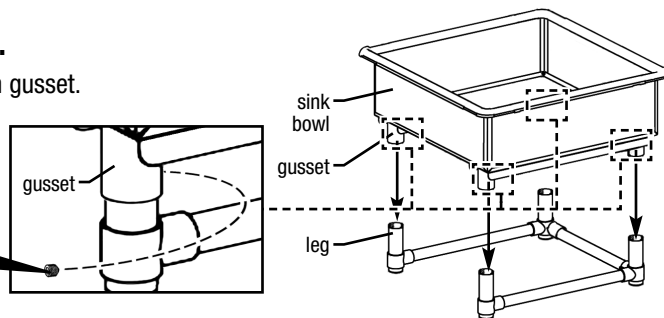

(continued on back page)

EG10070 Revised 02/23

Mobile Soak Sink

ASSEMBLY INSTRUCTIONS

Step 4 - Attach casters.

- Lay unit on its top.
- On caster, hold bottom nut and tighten knurled nut until applicator starts to expand.
- Insert caster into leg. Caster should fit snugly. If loose, tighten knurled nut more.
- With caster fully inserted into leg, tighten bottom nut with adjustable wrench.
- Flip unit onto its casters.

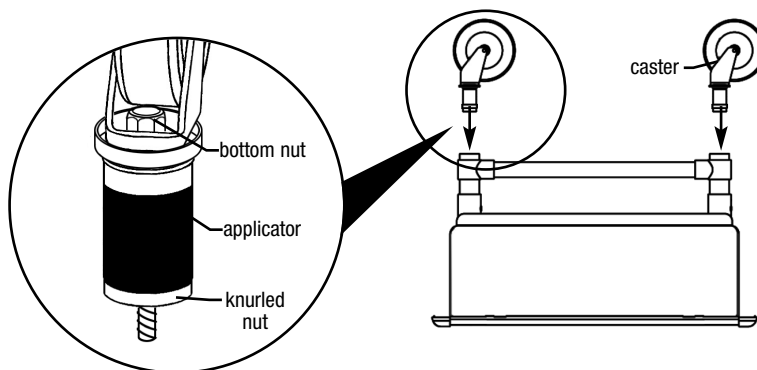

Step 5 - Attach lever drain to sink (referring to illustration at right).

- Remove the Snap-in Strainer and unscrew the Face Flange from the Drain Body. Apply a bead of Plumber's Putty to the bottom of the Face Flange where it contacts the sink bowl.
- Make sure the underside and inside mating surfaces of the sink bowl in the area of the drain are clean.
- Install the Drain Body and Gasket from below the sink.
- Install the Face Flange thru the sink drain opening and screw it into the Drain Body below.
- Before tightening, position the Handle to the desired location. Tighten the Face Flange securely with a sink flange tool or similar.
- Place Tailpiece Washer inside top of Tailpiece. To attach the Tailpiece, screw Coupling Nut onto the bottom of the Drain Body.

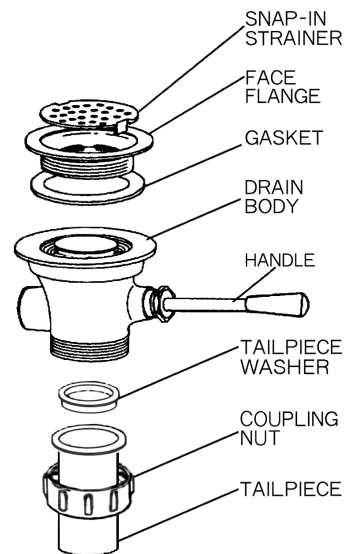

If a chute is provided with sink, proceed below to Step 6.

Step 6 - Attach chute.

- Set chute inside sink bowl, and hook to inner bracket.
- Attach chute to brackets using wing nuts and washers supplied.

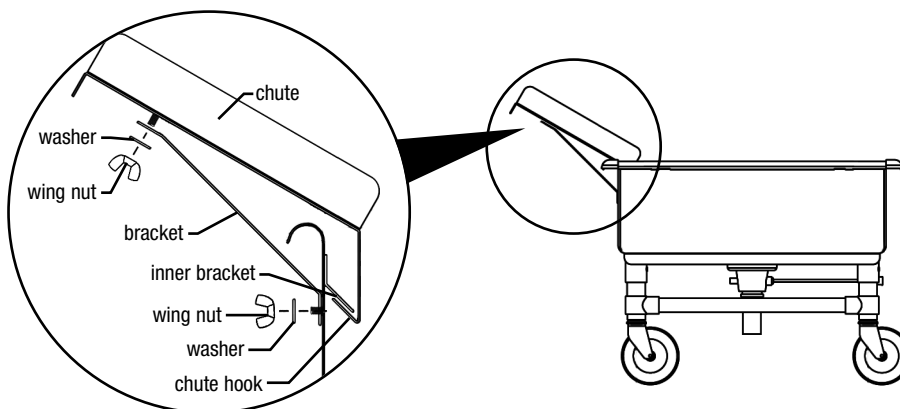

Place basket (if provided) inside sink bowl. Assembly is complete.

(End)