

# USER MANUAL

## Crawlspace Dehumidifier

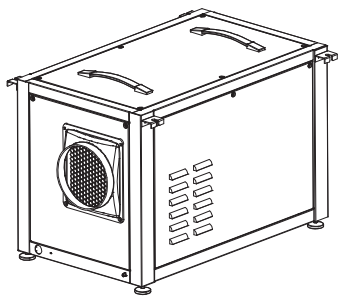

This manual applies to the following dehumidifier models:

- AFD2.5D
- AFD2.0DPM With Pump
- AFD2.5DPM With Pump
- AFD3.5DPM With Pump

Please read this manual carefully before operating the device and keep it for future reference.

# Message from WAYKAR

Thank you for choosing Waykar. Established with a commitment to protecting indoor climates, Waykar has grown into a leading brand in the HVAC industry, known for premium products that prioritize comfort and health in your indoor space.

Before you start exploring this product, read this manual carefully for necessary instructions first. It's advised to keep it for future reference.

## 24/7 Full-Time Response

Upon receipt of the dehumidifier, kindly inspect the package contents immediately for any potential missing or damaged parts. In case of issues, we would appreciate your prompt contact with Waykar support for solutions before initiating a return. Send us an email or scan the QR code to start a live chat.

**support@waykar.com**



## Important: Please Read Before Usage

Ensure the dehumidifier is always kept in an upright position to avoid internal damage. After unwrapping the dehumidifier, please set it upright and let it sit for **24 HOURS** before plugging it in.

We may not be superheroes for life—but we can be your HERO for this dehumidifier. Just reach out anytime.

Not collecting water? Missing parts?

Need setup help or missed the return window?

No worries – we've got your back!

Waykar Customer Support – Available 24/7

✉ support@waykar.com 📞 (213)-895-4871



# Table of Contents

PARTS ILLUSTRATION.....	01
PACKAGE CONTENTS.....	02
DEVICE POSITIONING & PLACEMENT.....	02
INSTALLATION GUIDE.....	03
FUNCTION OVERVIEW.....	05
OPERATION INSTRUCTIONS.....	07
TROUBLESHOOTING.....	10
MAINTENANCE & CLEANING.....	11
GENERAL SAFETY PRECAUTIONS.....	12
SPECIFICATIONS.....	22
WARRANTY & CONTACT.....	24

# PARTS ILLUSTRATION

This manual applies to multiple Waykar dehumidifier models. The product illustrations are for reference only. Please verify your model and refer to the appropriate illustration.

## Applicable to AFD2.0DPM (with Pump)

(Front Side)

(Back Side)

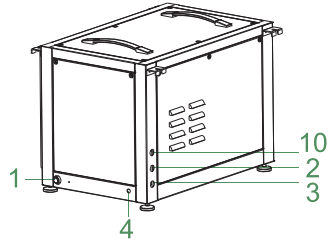
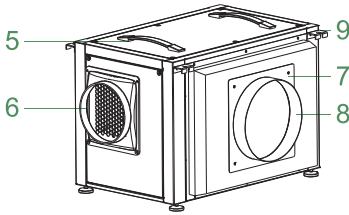

## Applicable to AFD2.5D and AFD2.5DPM (with Pump)

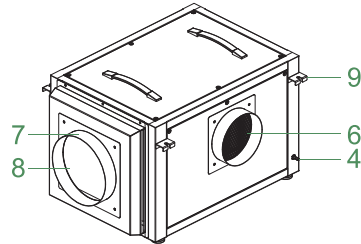
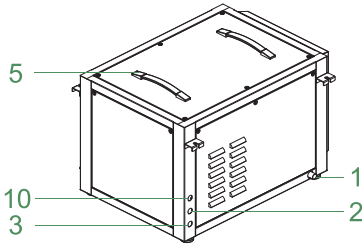

## Applicable to AFD3.5DPM (with Pump)

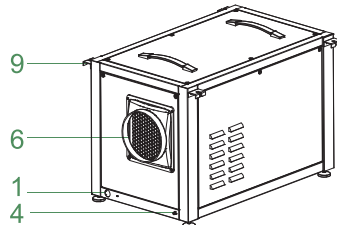
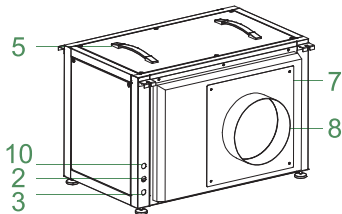

Note:

The filter position may vary by model. Please refer to the actual product.

# PARTS ILLUSTRATION

Part No.	Part Name	Part No.	Part Name
1	Gravity Drain Port	6	Air Outlet
2	External Controller Port	7	Duct Mount
3	Power Cable	8	Air Inlet (with Removable Filter)
4	Pump Drain Port (Pump Models Only)	9	Mounting Bracket
5	Lift Handle	10	Humidity Sensor Port

# PACKAGE CONTENTS

Package contents may vary by model. Please refer to the corresponding description for your dehumidifier model and verify that all listed items are included. If any item is missing or damaged, contact Waykar Customer Support for assistance

## Applicable to AFD2.5D

The package of the dehumidifier includes:

- 1 × Dehumidifier
- 1 × Humidity Sensor with Cable
- 1 × Wired Remote Controller with Cable
- 1 × Drain Hose
- 1 × User Manual

## Applicable to AFD2.0DPM, AFD2.5DPM and AFD3.5DPM

The package of the dehumidifier includes:

- 1 × Dehumidifier
- 1 × Humidity Sensor with Cable
- 1 × Wired Remote Controller with Cable
- 1 × Drain Hose
- 1 × Pump Drain Hose
- 1 × User Manual

# DEVICE POSITIONING & PLACEMENT

- The operational temperature range for the dehumidifier must be maintained between 41°F to 100°F (5–38°C). Operation outside of this specified temperature range may lead to potential damage to the product. Therefore, please do not place the device in an area where temperatures fall outside of this range.
- When positioning the dehumidifier, please ensure it is not placed too close to walls or other objects, as this could obstruct the air vents. Maintain a min. distance of 39 inches above and around the device.
- Store in a well ventilated room without continuously operating flames or other potential ignition sources. Minimum room area (operating or storage), 5 m<sup>2</sup> (54 ft<sup>2</sup>)

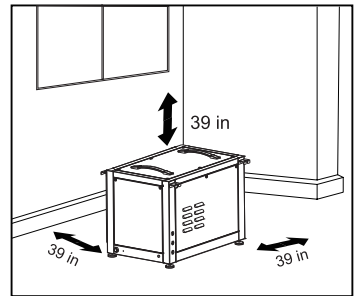

# INSTALLATION GUIDE

Humidity Sensor Port

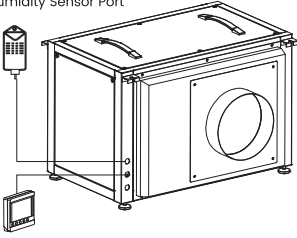

External Controller Port

**Step 1:** Locate the humidity sensor in the package and plug it into the matching port.

**Step 2:** Connect the remote control panel to the external controller port.

**Step 3:** Press Power on the control panel to start the dehumidifier.

**Tip:** Always connect the humidity sensor first to avoid an E4 error.

## Gravity Hose Connection

Condensation is a natural part of the dehumidification process. To ensure proper water disposal, always connect a drain hose before turning on the unit.

For models without a built-in pump, or when not using the pump function on pump-equipped models, follow the steps below to set up gravity drainage properly.

The drain hose has a 16mm inner diameter. For long-distance drainage, you can connect a garden hose (Not Included) to the drain port.

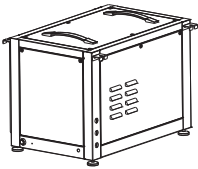

**Step One:** Locate the Gravity Drain Port.

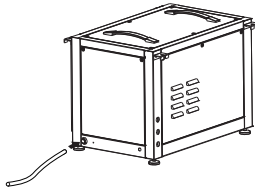

**Step Two:** Connect the drain hose to the port and ensure it is securely tightened.

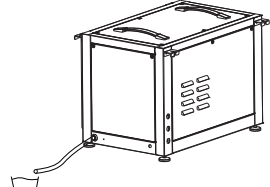

**Step Three:** Direct the other end of the hose into a container or floor drain.

### Note:

1. The hose should run smoothly downward, without bending or twisting, to prevent water leakage.

2. As this manual covers multiple dehumidifier models with gravity drain ports positioned on different sides, the illustrations above are for reference only. Please locate the Gravity Drain Port on your unit and connect the drain hose properly.

# INSTALLATION GUIDE

## Pump Hose Connection

(Applicable to AFD2.0DPM, AFD2.5DPM, and AFD3.5DPM only)

For pump-equipped models, you can attach the included pump hose to enable vertical water lift or long-distance drainage.

The pump is set to "ON" by default and will remain active after each power cycle. The "Pump" icon will light up on the display to indicate that the pump is activated.

Once the internal water reservoir reaches the predesignated full line, the pump will automatically drain the water. When the "Pump" icon starts flickering, it signals that the water pumping process is in progress.

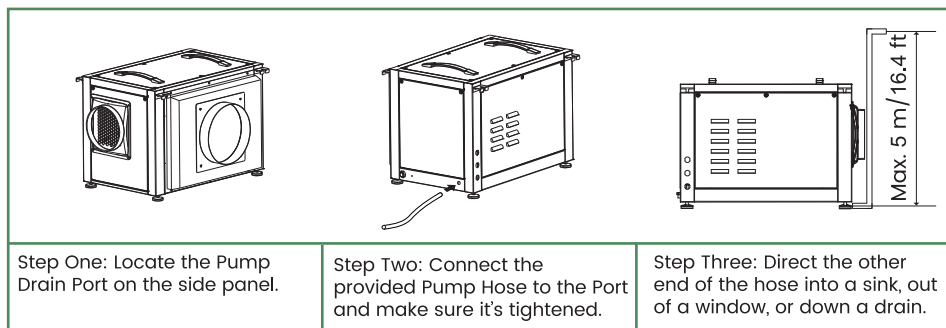

### Note:

Ensure the pump drain hose is securely attached before turning on the dehumidifier. If the unit operates without a hose connected, the pump may discharge water onto the floor when the internal reservoir reaches full capacity.

The pump supports a maximum water lift of 16.4 ft. Exceeding 15 ft in vertical drain height may result in water leakage.

When attaching the pump drain hose for drainage, ensure that the Gravity Drain Port is securely plugged to prevent any water leakage. If there is a leak at the Gravity Drain Port, the water will not reach the full water line of the pump, and as a result, the pump drainage will not be triggered automatically.

Additionally, make sure the drain hose is free of kinks or twists to avoid any water leakage during operation.

# FUNCTION OVERVIEW

## 1. Control Panel Illustration

For Non-Pump Models (AFD2.5D)

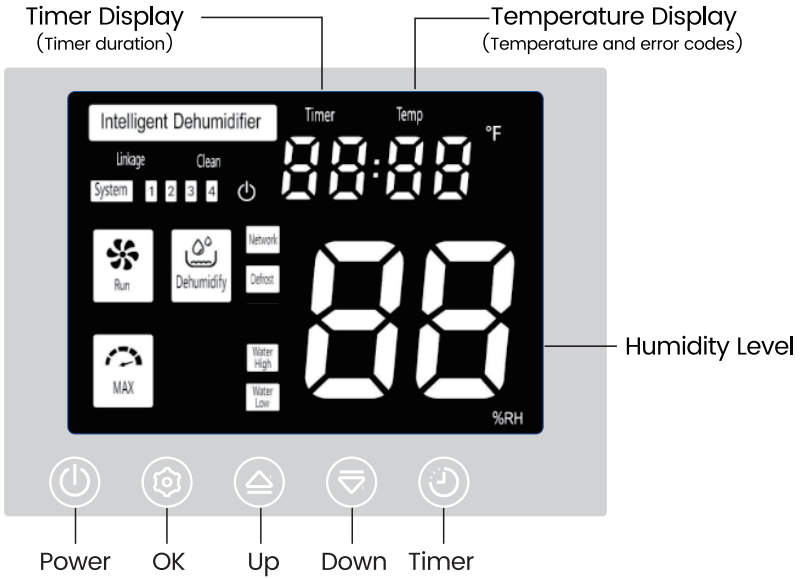



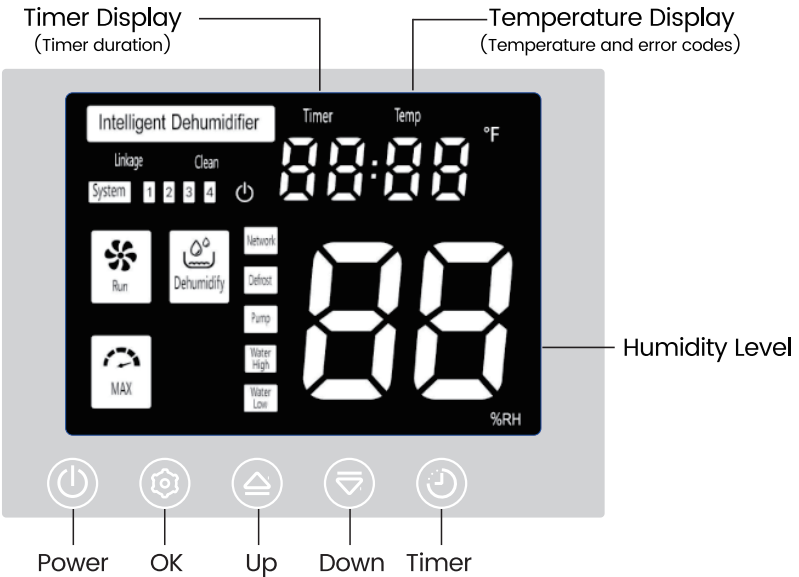

For Pump Models (AFD2.0DPM, AFD2.5DPM, AFD3.5DPM)









# FUNCTION OVERVIEW

## 2. Button Description

	<b>Power</b> Turns the dehumidifier on or off.		<b>OK</b> To confirm the setting for the device.
	<b>Up</b> Increases humidity level or timer setting.		<b>Down</b> Decreases humidity level or timer setting.
	<b>Timer</b> Sets or cancels the timer for the dehumidifier.		

## 3. Indicator Description

Icon	Meaning	Status
	Standby Indicator	On: Dehumidifier in standby. Off: Dehumidifier running.
	Compressor Symbol	On: Compressor is running. Off: Compressor is off. Flicker: Compressor start is delayed.
	Fan Icon	On: Fan is running. Off: Fan is off. Flicker: Fan start is delayed. Flickering with Humidity: Target humidity level reached.
	Defrosting Indicator	On: Defrosting in progress. Off: Defrosting complete.
		On: Continuous dehumidification activated (target humidity set to 10% RH).
		On: High-temperature protection activated.
		On: Low-temperature protection activated.

### For Pump Models ONLY

	Pump Indicator	On: Pump is activated (by default). Flickering: Pump is actively draining water.
--	----------------	---

# OPERATION INSTRUCTIONS

## Power On/Off & Standby Mode

1. Press the [⏻] button to turn on/off the dehumidifier.
2. When the device is on, press the [⏻] button to enter standby mode, and the standby indicator "⏻" will light up on the display.

### Dehumidifier Status Description

Dehumidifier Status	Compressor	Fan
Turning On	Starts after a brief delay	Immediately starts
Turning Off	Immediately stops	Continues running for a few seconds

### Power-off Memory Restart

In the event of an unexpected power failure or accidental unplugging, the dehumidifier offers automatic restart, seamlessly resuming operation with your previously saved settings once power is restored.

Please note that any set timer will be interrupted and require resetting.

### 3-Minute Delay Compressor Protection

In the event of frequent power cycling, the 3-minute delay protection mechanism will be triggered to enforce a 3-minute delay before restarting the compressor.

During this delay, only the fan will operate, noticeable by the cool air from the air outlet. Once the compressor kicks in, warm air will be expelled from the air outlet.

### Smart Humidity Control

When the humidity level drops to 3% RH below your preset target, the compressor will pause, and the fan icon "✿" along with the humidity value will flash on the screen.



The unit will resume operation once the humidity rises above the target level by more than 3%RH, ensuring efficient humidity control.

## Humidity Setting

1. When the dehumidifier is on, press [△] or [▽] to enter the humidity setting. The preset target humidity level will blink on the display.

# OPERATION INSTRUCTIONS

---

2. Next, press [] or [] to set your preferred humidity between 10% and 98% RH, in increments of 1% RH. Or press and hold the buttons to realize continuous adjustment.
3. After finishing the setting, press [] to confirm, or wait until it auto exits.

## Auto Defrosting

This function enables the dehumidifier to automatically detect and address frost build-up on its coils for better efficiency in cold conditions. During defrosting, the "" symbol appears on the screen.





## Continuous Dehumidifying

Set the humidity level to 10% RH to activate continuous dehumidifying mode, and the "" icon will illuminate.





## Timer Setting

Use the timer setting to schedule the dehumidifier to automatically turn on or off. Please note: The 24-hour timer is for one-time operation only and cannot be set to repeat. Additionally, be aware that any timer settings will be cleared if the power is interrupted or if the unit is turned off and then back on again.

### Programmed Shut-down:

1. Press [] to access the timer setting. The timer symbol and the default duration (00) will flash on the display.
2. Press [] or [] button to adjust timer duration, ranging from 00 to 24 hours.
3. After selecting the timer length, press [] to confirm the setting, or wait a few seconds for automatic exit. The timer symbol will remain illuminated with set duration.
4. To cancel the timer, manually set the timer duration to 00.

### Programmed Start-up:

1. In standby mode, the [] button is still functional for setting an auto-on timer.
2. Press the [] button to access the timer setting first. Then select the timer length using the [] or [] button.

# OPERATION INSTRUCTIONS

---

3. Once a timer is successfully set, the timer symbol will remain illuminated, and the remaining hours will appear on the display.
4. You can preset the humidity for the programmed start-up. The dehumidifier will automatically start with these predefined settings once the time is up.

## Error Code Explanation

Number	Code	Recommended Actions
1	E1	Replace the temperature and humidity sensor.
2	E2	Replace the temperature sensor.
3	E4	Replace the temperature and humidity sensor.
4	E6	Check if the display wire is properly connected.
5	-H	Wait until the device temperature goes down and it will resume working.
6	-L	Wait until the device temperature goes up and it will resume working.
<b>Applicable to AFD2.0DPM, AFD2.5DPM, and AFD3.5DPM Only</b>		
7	E3/EP	Pump failure detected. Contact the manufacturer for repair or replacement.

### Note:

The dehumidifier can still operate with certain functions disabled under E1, E2, or E4 errors.

Ensure the humidity sensor is connected before powering on the unit. Failure to do so will trigger a beeping alarm on the wired controller, displaying the "E4" error code on the screen.

If the error codes persist after following the recommended steps, please contact the Waykar Customer Support Team at [support@waykar.com](mailto:support@waykar.com) for further assistance.

# TROUBLESHOOTING

In the event of product malfunctions, please refer to the guide below to troubleshoot common issues that may arise with general dehumidifiers. If problems persist, kindly disconnect the dehumidifier and promptly contact Waykar Customer Service for assistance.

Problems	Detailed Description	Solutions
Not working	Dark display	Check the power port for damage or loose connection.
	Defrost icon lights up	Defrost in progress, and the indicator will go off when defrosting is finished.
	"-H" icon appears on the display	The device should not be used in high-temperature conditions.
	"-L" icon appears on the display	The device should not be used in low-temperature conditions.
Much Noise	The device sits on uneven surface.	Move it to a flat and even area.
	Dust build-up on the filter?	Refer to the Maintenance & Cleaning section of the manual for instructions on cleaning the filter.
	The air inlet or outlet may be blocked.	Ensure that the inlet or outlet is kept clear of any objects.
Water leakage	Loose hose connection	Ensure that the hoses are firmly attached.
	Tilted device	Place the dehumidifier on even ground.
	Blocked drain port	Clean the port and ensure the drain hose is clear and smooth.
E4 error code	Humidity sensor not connected	Check that the humidity sensor is firmly connected.
	Sensor or cable damaged	Inspect the sensor and cable for any damage.
	Defective sensor	Contact Waykar for replacement.

**E3 or E3/EP flashing:** The internal reservoir is full and water cannot drain properly [Note: This Error ONLY Applies to Pump Models].

## Step 1 – Drain the water

- If using gravity drain, make sure a drain hose is connected and not blocked or kinked.
- If no gravity hose is connected, attach one to drain the reservoir.

## Step 2 – Reset the unit

After the water drains, the display may show "EP " error. Turn the unit OFF, wait for 5 minutes, then turn it ON to clear the error.

**If the error returns:** Confirm the pump drain height does not exceed 16.4 ft (5 m). If within limit, then internal pump components may require service. Contact support if needed.

# MAINTENANCE & CLEANING

---

## Maintenance

Always remember to unplug the dehumidifier first before cleaning or handling the device. Steel wool, detergent, and other chemicals are not allowed for cleaning the dehumidifier.

## Filter Cleaning

The dehumidifier comes with a removable filter. It is advised to regularly clean the filter for dust, smoke, animal dander, mold spores, and pollen in order to reduce airborne allergens in the air.

1. Use a vacuum cleaner to gently remove dust from the filter surface.
2. If the filter is very dirty, clean it with warm water and mild detergent, and ensure it is completely dry.
3. Put the filter back into the dehumidifier.

## Device Storage

While it's recommended to run the dehumidifier year-round for a comfortable environment, follow these steps for proper storage during extended periods of non-use to preserve performance and lifespan.

1. Firstly, unplug the unit and allow it to cool.
2. Detach the drain hose, and clean the drain port.
3. Clean and dry the filter.
4. Wrap the power cord neatly.
5. Cover the device with a breathable cloth to protect it from dust.
6. Store it in a dry and well-ventilated place, away from direct sunlight.

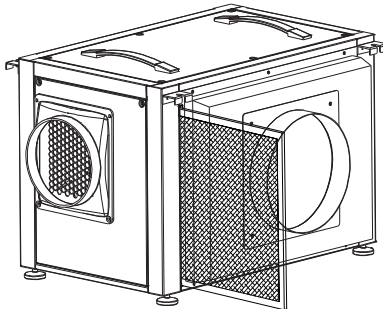

# GENERAL SAFETY PRECAUTIONS

---

- The dehumidifier is designed for indoor use only and is not intended for operation on public transport, such as buses, subways, and trains.
  - Avoid placing the device on soft, shaky, or uneven ground, as this may cause vibration and movement during operation.
  - Verify that the dehumidifier's voltage matches your electrical supply and plug it into grounded outlets in accordance with local regulations regarding electrical safety.
  - Avoid contact with water as the dehumidifier is not waterproof.
  - Ensure that the drain hose runs downward without bending or winding to facilitate continuous water drainage.
- 
- Be sure to unplug the dehumidifier first before cleaning or packing it.
  - Turn off the dehumidifier before unplugging the device.
  - For damaged cords, please contact the manufacturer or certified technicians for replacement to avoid hazards.
  - Do not dismantle or modify the device without professional certification. Such actions may lead to safety hazards and void the warranty.
  - If the dehumidifier is not going to be used for an extended period, please remember to unplug it.
- 
- Keep the dehumidifier away from direct sunlight, heat-generating devices, and flammable materials, including stoves, gasoline, etc.
  - Avoid sitting, standing, or placing heavy objects on the device.
  - No pesticides or flammable liquids are allowed near the device.
  - Avoid inserting fingers, rods, or other thin objects into the air inlet and outlet grilles of the dehumidifier.
  - Stop and unplug the device immediately at any sign of malfunction.
  - As condensate water accumulates inside the reservoir, do not tilt the dehumidifier to prevent water from spilling and causing damage.

# GENERAL SAFETY PRECAUTIONS

- Before moving or lifting the dehumidifier, fully drain the internal reservoir through the gravity drain port and disconnect the drain hose.
- Children aged 8 and above, as well as individuals with reduced physical, sensory, or mental capabilities, should operate the device only under supervision. Children under 8 should not tamper with it.
- Use soft cloth for cleaning and avoid splashing water directly on it.
- Neutral detergents are recommended for cleaning the dehumidifier. Alcohol, gas, benzene, and other chemical solvents are prohibited for cleaning purposes.

## WARNING

Do not use means to accelerate the defrosting process or to clean, other than those recommended by the manufacturer.

Risk of Fire—Store in a well-ventilated room without continuously operating flames or other potential ignition. Do not pierce or burn.

Be aware that refrigerants may not contain an odour.



- **WARNING** – Risk of Fire. Flammable Refrigerant Used. To Be Repaired Only By Trained Service Personnel. Do Not Puncture Refrigerant Tubing.
- **WARNING** – Risk of Fire. Dispose of Properly In Accordance With Federal Or Local Regulations. Flammable Refrigerant Used.
- **WARNING** – Risk of Fire. Flammable Refrigerant Used. Consult Repair Manual/Owner's Guide Before Attempting To Service This Product. All Safety Precautions Must Be Followed.
- **WARNING** – Risk of Fire due to Flammable Refrigerant Used. Follow Handling Instructions Carefully in Compliance with National Regulations.
- **WARNING** – Appliance shall be installed, operated and stored in a room with a floor area larger 5 m<sup>2</sup> (54 ft<sup>2</sup>).
- Device maintenance and repair should be left to trained professionals due to the potential safety hazards and environmental concerns associated with refrigerant leaks. Certified technicians can consult the [Maintenance & Cleaning](#) section in this manual for warnings regarding the safe use of flammable R32 refrigerant.

# GENERAL SAFETY INSTRUCTIONS

---

## **Transportation, marking and storage for units that employ flammable refrigerants**

### **1. General**

The following information is provided for units that employ FLAMMABLE REFRIGERANTS.

### **2. Transport of equipment containing flammable refrigerants**

Attention is drawn to the fact that additional transportation regulations may exist with respect to equipment containing flammable gas. The maximum number of pieces of equipment or the configuration of the equipment permitted to be transported together will be determined by the applicable transport regulations.

### **3. Marking of equipment using signs**

Signs for similar appliances used in a work area are generally addressed by local regulations and give the minimum requirements for the provision of safety and/or health signs for a work location. All required signs are to be maintained and employers should ensure that employees receive suitable and sufficient instruction and training on the meaning of appropriate safety signs and the actions that need to be taken in connection with these signs.

The effectiveness of signs should not be diminished by too many signs being placed together. Any pictograms used should be as simple as possible and contain only essential details.

### **4. Disposal of equipment using flammable refrigerants**

See national regulations.

### **5. Storage of equipment/appliances**

The storage of the appliance should be in accordance with the applicable regulations or instructions, whichever is more stringent.

### **6. Storage of packed (unsold) equipment**

Storage package protection should be constructed in such a way that mechanical damage to the equipment inside the package will not cause a leak of the REFRIGERANT CHARGE. The maximum number of pieces of equipment permitted to be stored together will be determined by local regulations.

## **Requirements for operation, service and installation manuals of appliances using flammable refrigerants**

### **Qualification of workers**

The manual shall contain specific information about the required qualification of the working personnel for maintenance, service and repair operations. Every working procedure that affects safety means shall only be carried out by competent persons.

### **Examples for such working procedures are:**

- breaking into the refrigerating circuit;
- opening of sealed components;

## **Competence of service personnel**

### **1. General**

Information of procedures additional to usual information for refrigerating appliance installation, repair, maintenance and decommission procedures is required when an appliance with FLAMMABLE REFRIGERANT is affected.

The training of these procedures is carried out by national training organisations or manufacturers that are accredited to teach the relevant national competency standards that may be set in legislation.

The achieved competence should be documented by a certificate.

# GENERAL SAFETY INSTRUCTIONS

---

## 2. Information and training

2.1) The training should include the substance of the following.

2.2) Information about the explosion potential of FLAMMABLE REFRIGERANTS to show that flammables may be dangerous when handled without care.

2.3) Information about POTENTIAL IGNITION SOURCES, especially those that are not obvious, such as lighters, light switches, vacuum cleaners, electric heaters.

2.4) Information about the different safety concepts:

- Unventilated-Safety of the appliance does not depend on ventilation of the housing.
- Switching off the appliance or opening of the housing has no significant effect on the safety.
- Nevertheless, it is possible that leaking refrigerant may accumulate inside the enclosure and flammable atmosphere will be released when the enclosure is opened.
- Ventilated enclosure-Safety of the appliance depends on ventilation of the housing.
- Switching off the appliance or opening of the enclosure has a significant effect on the safety.
- Care should be taken to ensure sufficient ventilation before.
- Ventilated room -Safety of the appliance depends on the ventilation of the room.
- Switching off the appliance or opening of the housing has no significant effect on the safety.
- The ventilation of the room shall not be switched off during repair procedures.

2.5) Information about refrigerant detectors:

- Principle of function, including influences on the operation.
- Procedures, how to repair, check or replace a refrigerant detector or parts of it in a safe way.
- Procedures, how to disable a refrigerant detector in case of repair work on the refrigerant carrying parts.

2.6) Information about the concept of sealed components and sealed enclosures according to IEC60079-15:2010.

2.7) Information about the correct working procedures:

a) Commissioning

- Ensure that the floor area is sufficient for the REFRIGERANT CHARGE or that the ventilation duct is assembled in a correct manner.
- Connect the pipes and carry out a leak test before charging with refrigerant.
- Check safety equipment before putting into service.

b) Maintenance

- Portable equipment shall be repaired outside or in a workshop specially equipped for servicing units with FLAMMABLE REFRIGERANTS.
- Ensure sufficient ventilation at the repair place.
- Be aware that malfunction of the equipment may be caused by refrigerant loss and a refrigerant leak is possible.
- Discharge capacitors in a way that won't cause any spark. The standard procedure to short circuit the capacitor terminals usually creates sparks.
- Reassemble sealed enclosures accurately. If seals are worn, replace them.
- Check safety equipment before putting into service.

c) Repair

- Portable equipment shall be repaired outside or in a workshop specially equipped for servicing units with FLAMMABLE REFRIGERANTS.
- Ensure sufficient ventilation at the repair place.
- Be aware that malfunction of the equipment may be caused by refrigerant loss and a refrigerant leak is possible.

# GENERAL SAFETY INSTRUCTIONS

---

- Discharge capacitors in a way that won't cause any spark.
  - When brazing is required, the following procedures shall be carried out in the right order:  
Remove the refrigerant. If the recovery is not required by national regulations, drain the refrigerant to the outside. Take care that the drained refrigerant will not cause any danger. In doubt, one person should guard the outlet. Take special care that drained refrigerant will not float back into the building.
    - Evacuate the refrigerant circuit.
    - Purge the refrigerant circuit with nitrogen for 5 min (not required for A2L REFRIGERANTS).
    - Evacuate again (not required for A2L REFRIGERANTS).
    - Remove parts to be replaced by cutting, not by flame.
    - Purge the braze point with nitrogen during the brazing procedure.
    - Carry out a leak test before charging with refrigerant.
  - Reassemble sealed enclosures accurately. If seals are worn, replace them.
  - Check safety equipment before putting into service.
- d) Disposal
- Ensure sufficient ventilation at the working place.
  - Remove the refrigerant. If the recovery is not required by national regulations, drain the refrigerant to the outside. Take care that the drained refrigerant will not cause any danger. In doubt, one person should guard the outlet. Take special care that drained refrigerant will not float back into the building.
  - When flammable refrigerants are used,
    - evacuate the refrigerant circuit.
    - purge the refrigerant circuit with oxygen free nitrogen.
    - evacuate again. (not required for A2L refrigerants);
    - cut out the compressor and drain the oil.

## Information on servicing

### 1. General

The manual shall contain specific information for service personnel according.

### 2. Checks to the area

Prior to beginning work on systems containing FLAMMABLE REFRIGERANTS, safety checks are necessary to ensure that the risk of ignition is minimised.

For repair to the REFRIGERATING SYSTEM

### 3. Work procedure

Work shall be undertaken under a controlled procedure so as to minimise the risk of a flammable gas or vapour being present while the work is being performed.

### 4. General work area

All maintenance staff and others working in the local area shall be instructed on the nature of work being carried out. Work in confined spaces shall be avoided.

### 5. Checking for presence of refrigerant

The area shall be checked with an appropriate refrigerant detector prior to and during work, to ensure the technician is aware of potentially toxic or flammable atmospheres. Ensure that the leak detection equipment being used is suitable for use with all applicable refrigerants, i. e. non-sparking, adequately sealed or intrinsically safe.

# GENERAL SAFETY INSTRUCTIONS

---

## 6. Presence of fire extinguisher

If any hot work is to be conducted on the refrigerating equipment or any associated parts, appropriate fire extinguishing equipment shall be available to hand. Have a dry powder or CO<sub>2</sub> fire extinguisher adjacent to the charging area.

### a) Commissioning

- Ensure that the floor area is sufficient for the REFRIGERANT CHARGE or that the ventilation duct is assembled in a correct manner.
- Connect the pipes and carry out a leak test before charging with refrigerant.
- Check safety equipment before putting into service.

### b) Maintenance

- Portable equipment shall be repaired outside or in a workshop specially equipped for servicing units with FLAMMABLE REFRIGERANTS.
- Ensure sufficient ventilation at the repair place.
- Be aware that malfunction of the equipment may be caused by refrigerant loss and a refrigerant leak is possible.
- Discharge capacitors in a way that won't cause any spark. The standard procedure to short circuit the capacitor terminals usually creates sparks.
- Reassemble sealed enclosures accurately. If seals are worn, replace them.
- Check safety equipment before putting into service.

### c) Repair

- Portable equipment shall be repaired outside or in a workshop specially equipped for servicing units with FLAMMABLE REFRIGERANTS.
- Ensure sufficient ventilation at the repair place.
- Be aware that malfunction of the equipment may be caused by refrigerant loss and a refrigerant leak is possible.
- Discharge capacitors in a way that won't cause any spark.
- When brazing is required, the following procedures shall be carried out in the following order:  
--Safely remove the refrigerant following local and national regulations. If the recovery is not required by national regulations, drain the refrigerant to the outside. Take care that the drained refrigerant will not cause any danger. In doubt, one person should guard the outlet. Take special care that drained refrigerant will not float back into the building;

### d) Decommissioning

- If the safety is affected when the equipment is putted out of service, the REFRIGERANT CHARGE shall be removed before decommissioning.
- Ensure sufficient ventilation at the equipment location.
- Be aware that malfunction of the equipment may be caused by refrigerant loss and a refrigerant leak is possible.
- Discharge capacitors in a way that won't cause any spark.
- Remove the refrigerant. If the recovery is not required by national regulations, drain the refrigerant to the outside. Take care that the drained refrigerant will not cause any danger. In doubt, one person should guard the outlet. Take special care that drained refrigerant will not float back into the building.
- When FLAMMABLE REFRIGERANTS except A2L REFRIGERANTS are used,  
--Evacuate the refrigerant circuit.

# GENERAL SAFETY INSTRUCTIONS

---

## 7. No ignition sources

No person carrying out work in relation to a REFRIGERATING SYSTEM which involves exposing any pipe work shall use any sources of ignition in such a manner that it may lead to the risk of fire or explosion. All possible ignition sources, including cigarette smoking, should be kept sufficiently far away from the site of installation, repairing, removing and disposal, during which refrigerant can possibly be released to the surrounding space. Prior to work taking place, the area around the equipment is to be surveyed to make sure that there are no flammable hazards or ignition risks. "No Smoking" signs shall be displayed.

## 8. Ventilated area

Ensure that the area is in the open or that it is adequately ventilated before breaking into the system or conducting any hot work. A degree of ventilation shall continue during the period that the work is carried out. The ventilation should safely disperse any released refrigerant and preferably expel it externally into the atmosphere.

## 9. Checks to the refrigerating equipment

Where electrical components are being changed, they shall be fit for the purpose and to the correct specification. At all times the manufacturer's maintenance and service guidelines shall be followed. If in doubt, consult the manufacturer's technical department for assistance. The following checks shall be applied to installations using.

### FLAMMABLE REFRIGERANTS:

- the actual REFRIGERANT CHARGE is in accordance with the room size within which the refrigerant containing parts are installed;
- the ventilation machinery and outlets are operating adequately and are not obstructed;
- if an indirect refrigerating circuit is being used, the secondary circuit shall be checked for the presence of refrigerant;
- marking to the equipment continues to be visible and legible. Markings and signs that are illegible shall be corrected;
- refrigerating pipe or components are installed in a position where they are unlikely to be exposed to any substance which may corrode refrigerant containing components, unless the components are constructed of materials which are inherently resistant to being corroded or are suitably protected against being so corroded.

## 10. Checks to electrical devices

Repair and maintenance to electrical components shall include initial safety checks and component inspection procedures. If a fault exists that could compromise safety, then no electrical supply shall be connected to the circuit until it is satisfactorily dealt with. If the fault cannot be corrected immediately but it is necessary to continue operation, an adequate temporary solution shall be used. This shall be reported to the owner of the equipment so all parties are advised.

### Initial safety checks shall include:

- that capacitors are discharged: this shall be done in a safe manner to avoid possibility of sparking;
- that no live electrical components and wiring are exposed while charging, recovering or purging the system;
- that there is continuity of earth bonding.

# GENERAL SAFETY INSTRUCTIONS

---

## 11. Repairs to sealed components

1) During repairs to sealed components, all electrical supplies shall be disconnected from the equipment being worked upon prior to any removal of sealed covers, etc. If it is absolutely necessary to have an electrical supply to equipment during servicing, then a permanently operating form of leak detection shall be located at the most critical point to warn of a potentially hazardous situation.

2) Sealed electrical components shall be replaced.

## 12. Repair to intrinsically safe components

Do not apply any permanent inductive or capacitance loads to the circuit without ensuring that this will not exceed the permissible voltage and current permitted for the equipment in use. Intrinsically safe components must be replaced.

Replace components only with parts specified by the manufacturer. Other parts may result in the ignition of refrigerant in the atmosphere from a leak.

## 13. Cabling

Check that cabling will not be subject to wear, corrosion, excessive pressure, vibration, sharp edges or any other adverse environmental effects. The check shall also take into account the effects of aging or continual vibration from sources such as compressors or fans.

## 14. Detection of flammable refrigerants

Under no circumstances shall potential sources of ignition be used in the searching for or detection of refrigerant leaks. A halide torch (or any other detector using a naked flame) shall not be used. The following leak detection methods are deemed acceptable for all refrigerant systems. Electronic leak detectors may be used to detect refrigerant leaks but, in the case of FLAMMABLE REFRIGERANTS, the sensitivity may not be adequate, or may need re-calibration. (Detection equipment shall be calibrated in a refrigerant-free area.)

Ensure that the detector is not a potential source of ignition and is suitable for the refrigerant used.

Leak detection equipment shall be set at a percentage of the LFL of the refrigerant and shall be calibrated to the refrigerant employed, and the appropriate percentage of gas (25 % maximum) is confirmed.

Leak detection fluids are also suitable for use with most refrigerants but the use of detergents containing chlorine shall be avoided as the chlorine may react with the refrigerant and corrode the copper pipe-work.

If a leak is suspected, all naked flames shall be removed/extinguished.

If a leakage of refrigerant is found which requires brazing, all of the refrigerant shall be recovered from the system, or isolated (by means of shut off valves) in a part of the system remote from the leak. Removal of refrigerant shall be according to Removal and evacuation.

## 15. Removal and evacuation

When breaking into the refrigerant circuit to make repairs -or for any other purpose- conventional procedures shall be used. However, for flammable refrigerants it is important that best practice be followed, since flammability is a consideration.

# GENERAL SAFETY INSTRUCTIONS

---

The following procedure shall be adhered to:

- safely remove refrigerant following local and national regulations;
- purge the circuit with inert gas(optional for A2L);
- evacuate(optional for A2L);
- continuously flush or purge with inert gas when using flame to open circuit ; and
- open the circuit.

The refrigerant charge shall be recovered into the correct recovery cylinders if venting is not allowed by local and national codes. For appliances containing flammable refrigerants, the system shall be purged with oxygen-free nitrogen to render the appliance safe for flammable refrigerants. This process might need to be repeated several times. Compressed air or oxygen shall not be used for purging refrigerant systems. For appliances containing flammable refrigerants, refrigerants purging shall be achieved by breaking the vacuum in the system with oxygen-free nitrogen and continuing to fill until the working pressure is achieved, then venting to atmosphere, and finally pulling down to a vacuum (optional for A2L). This process shall be repeated until no refrigerant is within the system (optional for A2L). When the final oxygen-free nitrogen charge is used, the system shall be vented down to atmospheric pressure to enable work to take place.

The outlet for the vacuum pump shall not be close to any potential ignition sources, and ventilation shall be available.

## 16. Charging procedures

In addition to conventional charging procedures, the following requirements shall be followed.

- Ensure that contamination of different refrigerants does not occur when using charging equipment. Hoses or lines shall be as short as possible to minimise the amount of refrigerant contained in them.
- Cylinders shall be kept in an appropriate position according to the instructions.
- Ensure that the REFRIGERATING SYSTEM is earthed prior to charging the system with refrigerant.
- Label the system when charging is complete (if not already).
- Extreme care shall be taken not to overfill the REFRIGERATING SYSTEM. Prior to recharging the system, it shall be pressure-tested with the appropriate purging gas. The system shall be leak-tested on completion of charging but prior to commissioning. A follow up leak test shall be carried out prior to leaving the site.

## 17. Decommissioning

Before carrying out this procedure, it is essential that the technician is completely familiar with the equipment and all its detail. It is recommended good practice that all refrigerants are recovered safely. Prior to the task being carried out, an oil and refrigerant sample shall be taken in case analysis is required prior to re-use of recovered refrigerant.

It is essential that electrical power is available before the task is commenced.

- a) Become familiar with the equipment and its operation.
- b) Isolate system electrically.
- c) Before attempting the procedure, ensure that:

# GENERAL SAFETY INSTRUCTIONS

---

- Mechanical handling equipment is available, if required, for handling refrigerant cylinders;
  - All personal protective equipment is available and being used correctly;
  - The recovery process is supervised at all times by a competent person;
  - Recovery equipment and cylinders conform to the appropriate standards.
- d) Pump down refrigerant system, if possible.
- e) If a vacuum is not possible, make a manifold so that refrigerant can be removed from various parts of the system.
- f) Make sure that cylinder is situated on the scales before recovery takes place.
- g) Start the recovery machine and operate in accordance with instructions.
- h) Do not overfill cylinders (no more than 80 % volume liquid charge).
- i) Do not exceed the maximum working pressure of the cylinder, even temporarily.
- j) When the cylinders have been filled correctly and the process completed, make sure that the cylinders and the equipment are removed from site promptly and all isolation valves on the equipment are closed off.
- k) Recovered refrigerant shall not be charged into another REFRIGERATING SYSTEM unless it has been cleaned and checked.

## 18. Labelling

Equipment shall be labelled stating that it has been de-commissioned and emptied of refrigerant. The label shall be dated and signed. For appliances containing FLAMMABLE REFRIGERANTS, ensure that there are labels on the equipment stating the equipment contains FLAMMABLE REFRIGERANT.

## 19. Recovery

When removing refrigerant from a system, either for servicing or decommissioning, it is recommended good practice that all refrigerants are removed safely. When transferring refrigerant into cylinders, ensure that only appropriate refrigerant recovery cylinders are employed. Ensure that the correct number of cylinders for holding the total system charge is available. All cylinders to be used are designated for the recovered refrigerant and labelled for that refrigerant (i. e. special cylinders for the recovery of refrigerant). Cylinders shall be complete with pressure-relief valve and associated shut-off valves in good working order. Empty recovery cylinders are evacuated and, if possible, cooled before recovery occurs. The recovery equipment shall be in good working order with a set of instructions concerning the equipment that is at hand and shall be suitable for the recovery of the flammable refrigerant. If in doubt, the manufacturer should be consulted. In addition, a set of calibrated weighing scales shall be available and in good working order. Hoses shall be complete with leak-free disconnect couplings and in good condition. The recovered refrigerant shall be processed according to local legislation in the correct recovery cylinder, and the relevant waste transfer note arranged. Do not mix refrigerants in recovery units and especially not in cylinders. If compressors or compressor oils are to be removed, ensure that they have been evacuated to an acceptable level to make certain that flammable refrigerant does not remain within the lubricant. The compressor body shall not be heated by an open flame or other ignition sources to accelerate this process. When oil is drained from a system, it shall be carried out safely.

# SPECIFICATIONS

## Applicable to AFD2.0DPM

Rated Voltage/Frequency	110V~60Hz
Total Input Current	7.26A
Input Power (at 65°F, 60% RH )	530W
Input Current (at 65°F, 60% RH )	4.62A
Moisture Removal Capacity (at 65°F, 60% RH)	42 Pints/Day (20.1 L)
Moisture Removal Capacity (at 80°F, 60% RH)	60 Pints/Day (28.6 L)
Moisture Removal Capacity (at 86°F, 80% RH)	96 Pints/Day (45.3 L)
Moisture Removal Capacity (at 95°F, 90% RH)	125 Pints/Day (59.0 L)
IEF (65°F, 60%RH)	1.60 L/kWh
Motor FLA	0.52A
Motor Compressor (RLA/LRA)	RLA: 5.4A LRA: 29A
Refrigerant/Qty	R32/220g
Maximum Allowable Pressure	798psi (5.5 Mpa)
High Pressure	580psi (4.0 Mpa)
Low Pressure	247psi (1.7 Mpa)

## Applicable to AFD2.5D and AFD2.5DPM

Rated Voltage/Frequency	115V/60Hz
Total Input Current	8.7 A
Input Power (at 65°F, 60% RH )	530 W
Input Current (at 65°F, 60% RH )	4.6 A
Moisture Removal Capacity (at 65°F, 60% RH)	48.5 Pints/Day (23L/Day)
Moisture Removal Capacity (at 80°F, 60% RH)	74 Pints/Day (35L/Day)
Moisture Removal Capacity (at 86°F, 80% RH)	123 Pints/Day (58L/Day)
Moisture Removal Capacity (at 95°F, 90% RH)	158 Pints/Day (74L/Day)
IEF (65°F, 60% RH)	1.60 L/kWh
Motor FLA	0.76A
Motor Compressor (RLA/LRA)	RLA:5.4 A LRA:29 A
Refrigerant/Qty	R32/280g
Maximum Allowable Pressure	5.5Mpa
High Pressure	4.0Mpa
Low Pressure	1.7Mpa

# SPECIFICATIONS

## Applicable to AFD3.5DPM

Rated Voltage/Frequency	115V/60Hz
Total Input Current	11 A
Input Power (at 65°F, 60% RH )	680 W
Input Current (at 65°F, 60% RH )	5.9 A
Moisture Removal Capacity (at 65°F, 60% RH)	65 Pints/Day (30.8L/Day)
Moisture Removal Capacity (at 80°F, 60% RH)	100 Pints/Day (47.3L/Day)
Moisture Removal Capacity (at 86°F, 80% RH)	156 Pints/Day (73.8L/Day)
Moisture Removal Capacity (at 95°F, 90% RH)	216 Pints/Day (102.2L/Day)
IEF (65°F, 60% RH)	1.9 L/kWh
Motor FLA	0.7A
Motor Compressor (RLA/LRA)	RLA:10 A LRA:40 A
Refrigerant/Qty	R32/375g
Maximum Allowable Pressure	5.5Mpa
High Pressure	4.0Mpa
Low Pressure	1.7Mpa

### Note:

Recommended operating temperature: 41°F to 100°F. The dehumidifier may experience malfunctions outside of this temperature range.

The manufacturer reserves the right to modify the product without formal notice to the public.

### **WARNING:**

This product can expose you to chemicals including styrene and its compounds, which are known to the State of California to cause cancer or birth defects or other reproductive harm. For more information go to [www.P65Warnings.ca.gov](http://www.P65Warnings.ca.gov).

### **Important:**

This warning is legally required by California's Proposition 65, which mandates disclosure even for trace amounts of certain substances. The warning does not indicate that the product is unsafe when used as intended; the risk primarily applies to long-term exposure to significant amounts of these substances. The levels in this product are negligible and within safe limits.

# WARRANTY & CONTACT

---

## We're Here to Support You

At Waykar, your satisfaction matters. If you have questions about your product, need assistance, or require replacement parts, our customer support team is ready to help.

Email: [support@waykar.com](mailto:support@waykar.com) | Phone: (213) 895-4871

## Manufacturer's Warranty

All Waykar products are covered by a 12-month limited manufacturer's warranty from the date of purchase. This warranty applies to products purchased directly from Waykar or through authorized retailers. An order invoice or proof of purchase may be required when requesting service.

## Extend Your Warranty by 1 Year

Register your product on our official website to enjoy an additional 12 months of warranty coverage—at no extra cost.

### How to register:

Visit [www.waykar.com](http://www.waykar.com) and complete the product registration form. Please include your Order ID and Date of Purchase, if applicable.

## What Is Not Covered

The warranty does not cover damage resulting from improper use or handling, including but not limited to:

1. Failing to follow the instructions in the manual.
2. Purposeful mishandling of the device.
3. Damaging the device through violent impact.
4. Exposing the device to liquids or infiltrating foreign particles.
5. Unauthorized modification or overhauling of the device.
6. Damage from placing the device upside down.

Normal wear and tear is not covered under warranty.

## WAYKAR Office

🏠 221 York Rd, Blacksburg, SC 29702 USA

✉ Email: [support@waykar.com](mailto:support@waykar.com)

☎ Tel: +1-(213)-895-4871

💬 Live Chat: [www.waykar.com](http://www.waykar.com)

🕒 24/7 Full-Time Response

\*Have your Order Number ready before contacting customer support.





Scan the QR code  
for Live Chat



@ Waykar

We hope our products will make your living space healthier and more comfortable.

Your satisfaction is our top priority.

Feel free to tag us when you share a snap on your social media.

---

WAYKAR All rights reserved.