

REVEL[®]

CONCERTA²[™]

Loudspeaker Owner's Manual

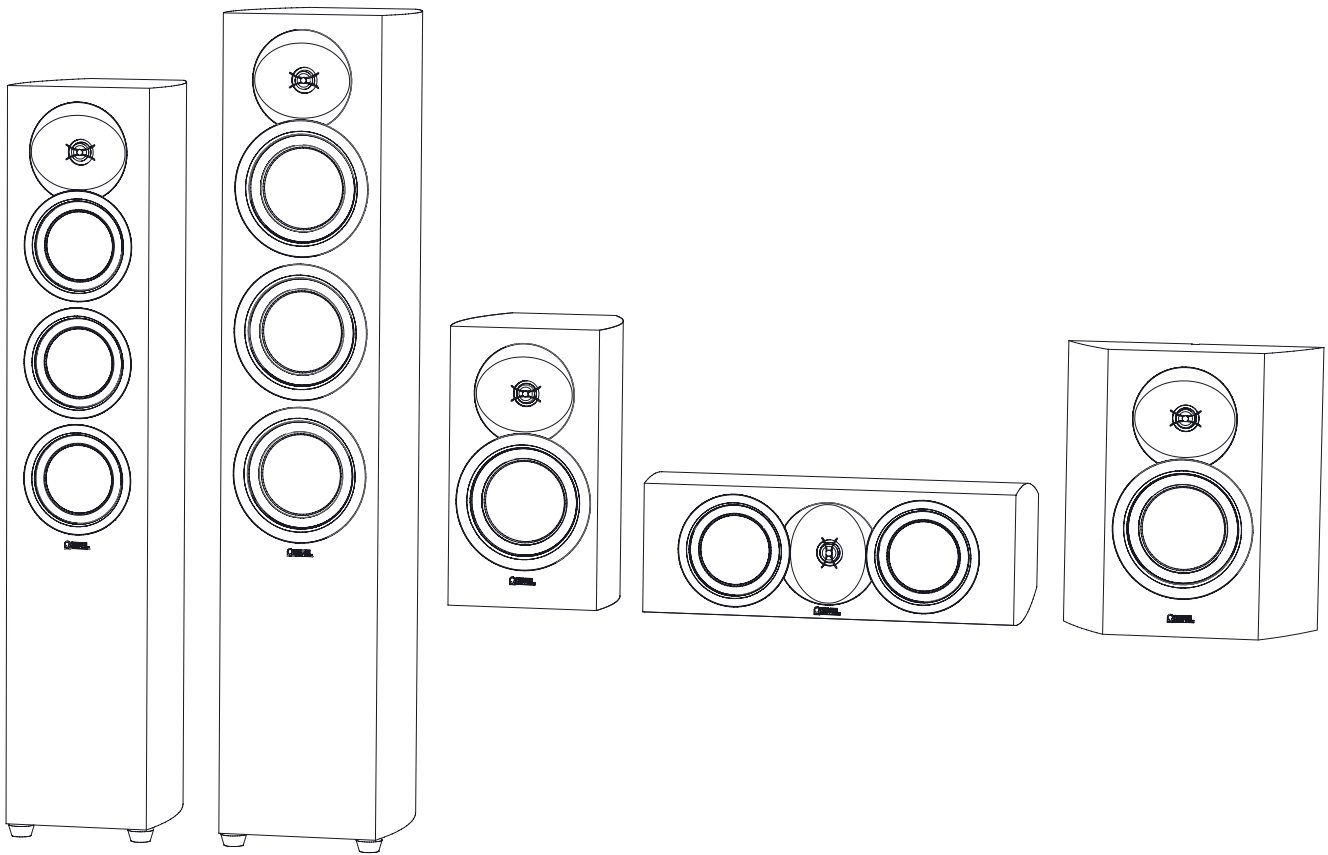

TABLE OF CONTENTS

About Revel Concerta2 Loudspeakers	2
Concerta2 Series Overview.....	3
Installation Considerations, Loudspeaker Placement.....	5
Making Connections	8
Caring for Your Loudspeakers	8
Specifications.....	9

ABOUT REVEL CONCERTA2 LOUDSPEAKERS SERIES

Thank you for purchasing Revel Concerta2 loudspeakers Series speakers. These true full-range loudspeakers feature small footprints and sleek designs, allowing them to blend-in easily with your existing décor. They deliver an impressive combination of wide frequency range, uncompressed dynamic range and low distortion across the entire audible spectrum.

Typical tweeter magnetic assemblies have a small space behind the dome that causes a high mechanical resonance. In designing the Concerta2 series, this challenge was met head on by Revel engineers. They created a tweeter mechanical resonance that is well below the operating band which would ensure linearity and consistency at the crossover frequency. To do so, a large cavity behind the magnetic assembly is vented around the perimeter. This, along with a compliant diaphragm surround, sets the mechanical resonance frequency to a low 800 Hz compared to a typical 1.5 kHz found in similarly priced speakers. These advances allowed the tweeter/midrange crossover to be set an octave lower thereby improving the system directivity.

By repositioning the voice coil in the woofer, Revel engineers discovered they could improve the symmetry of the woofer displacement and thereby lower distortion. Also, asymmetry attributed to spider non-linearity can also lead to higher distortion. This was solved by adjusting the spider progression to greatly improve the symmetry and as a result, lowered distortion.

A novel technique of cabinet construction was used to create Concerta2 enclosures that were not only beautiful, but also have the rigid, curved side walls plus extensive bracing that results in a strong and inert enclosure. This ensures no cabinet coloration to the sound. The attractive designs are also painted a high gloss white or high gloss black finish, have magnetic grilles and show no visible fasteners, features not typically seen on speakers at this price point.

Revel Concerta2 crossover networks feature carefully-selected components that contribute to great performance and benchmark setting value. These high-order crossover networks dramatically reduce distortion and dynamic compression for clear sound that maintains the same quality over a very wide dynamic range. These precision networks optimize the speakers' timbral accuracy, enhancing musical enjoyment for listeners who are anywhere in the room, not only those seated on-axis to the loudspeakers.

During development, every Revel loudspeaker model is compared to competitive models in our unique position-independent double-blind listening lab. This process utilizes the latest psychoacoustic research to assure that these listening tests are valid, enabling us to verify that all Revel loudspeakers are superior to their competitors before they are allowed to go into production.

CONCERTA2 SERIES OVERVIEW

F35/F36 OVERVIEW

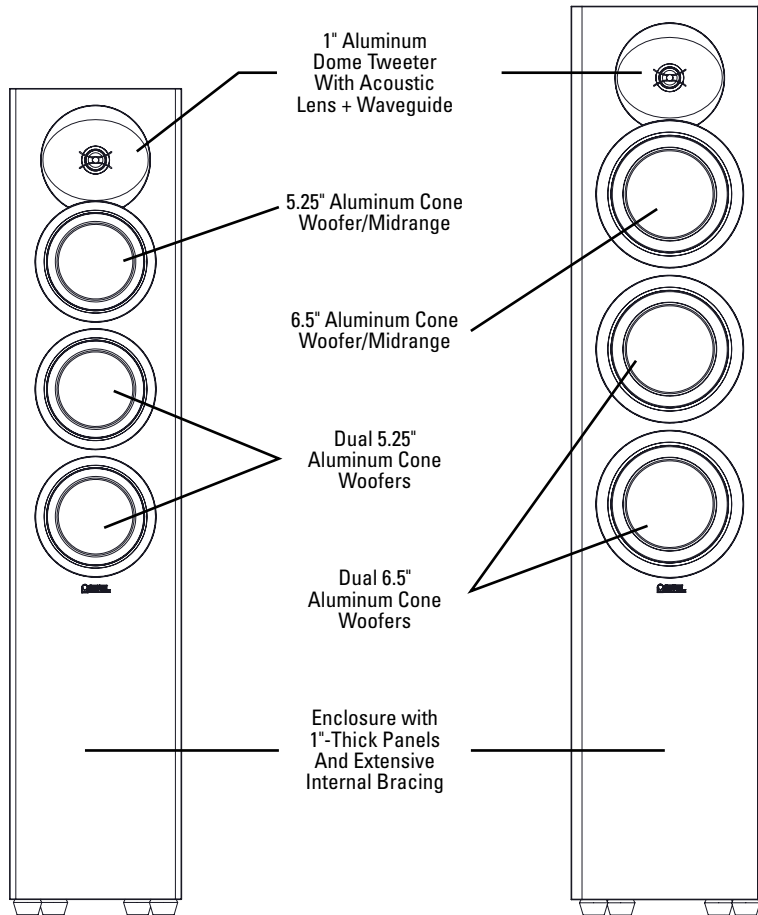

M16 OVERVIEW

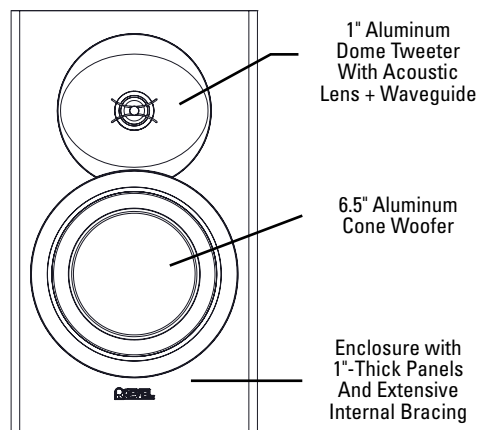

S16 OVERVIEW

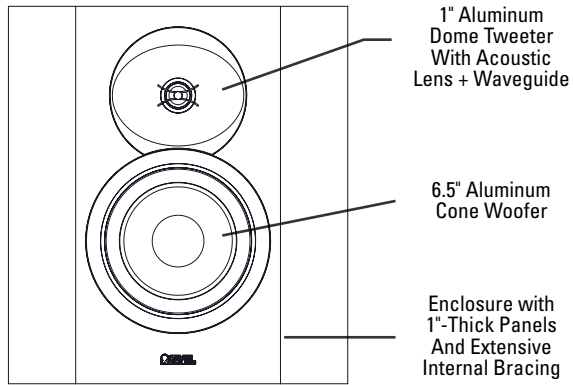

C25 OVERVIEW

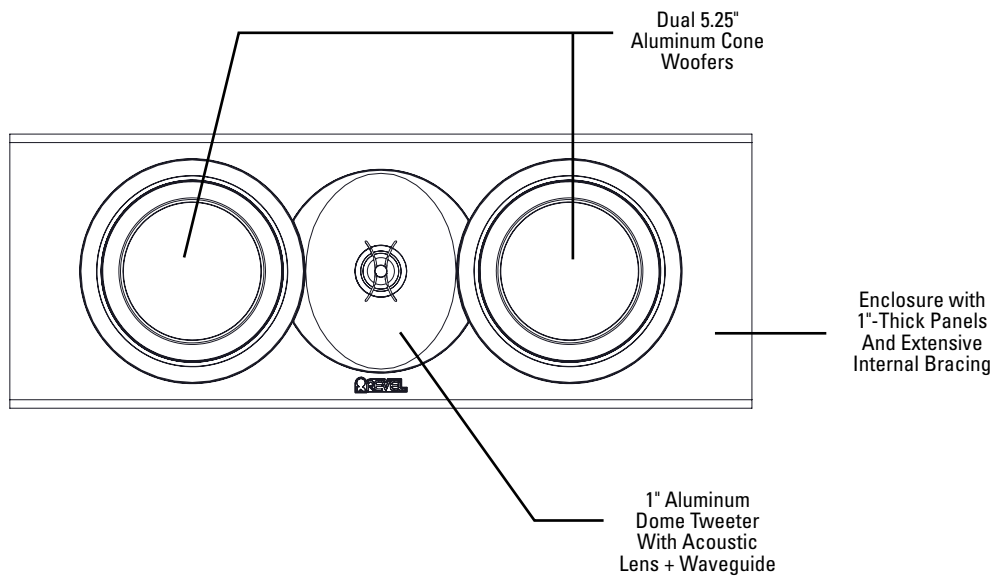

INSTALLATION CONSIDERATIONS

Loudspeaker fidelity depends on the following three factors: loudspeaker accuracy, loudspeaker placement and listening room acoustics. Advanced Revel design features allow the Concerta2 to achieve exceptional acoustical precision. As a result, experimenting with loudspeaker placement and listening room acoustics will have the most significant impact on the loudspeakers' performance.

LOUDSPEAKER PLACEMENT FOR F35, F36, AND M16

- Remove all obstructions between the loudspeaker and the primary listening position. For instance, a coffee table between the loudspeaker and the primary listening position will create reflections that will degrade stereo imaging and timbre. Placing the loudspeakers near large objects may also cause unwanted reflections.
- For the best stereo imaging, place the loudspeakers so that they are both the same distance from the primary listening position and so they are both the same distance from the side walls, as shown in the illustration.

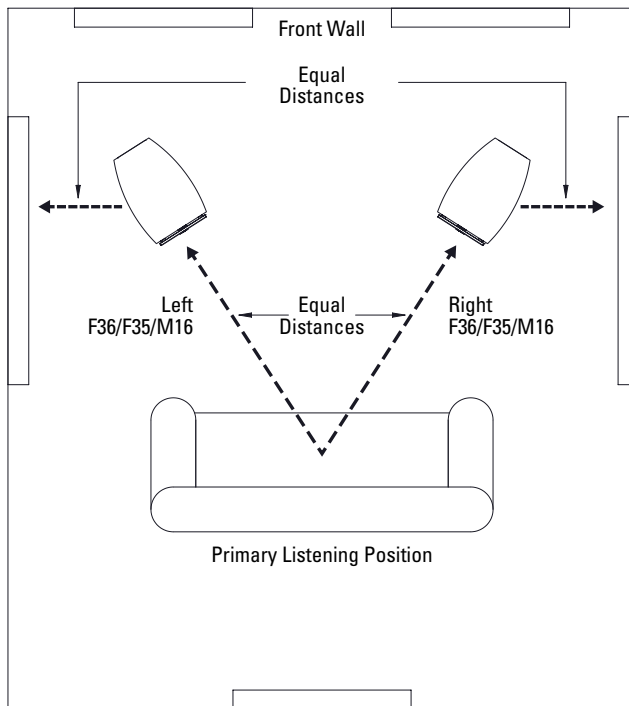

- For optimal stereo imaging and timbre, aim the loudspeakers directly toward the primary listening position as shown in the illustration above. If you wish to widen the stereo soundstage you can reduce this toe-in angle, even to the point at which the loudspeakers are pointing straight forward.
- Moving the loudspeakers farther from the front and side listening room walls will improve stereo imaging and the sense of spaciousness in the listening space.
- Moving the loudspeakers closer to the corners or walls of the listening room will increase bass level.

STAND-MOUNTING

Optional Concerta2 stands are available for the C25 and M16 that place the loudspeakers at the proper height for installation below a TV display. Refer to the assembly instructions that are included with the stands for additional information.

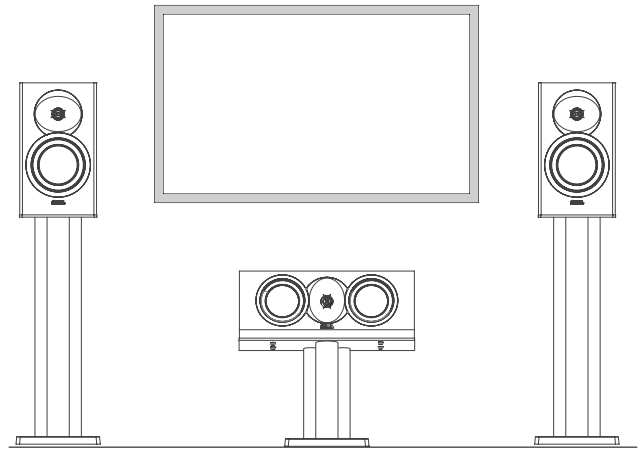

FLUSH-MOUNTING

When flush-mounting the C25 or M16 inside of a cabinet or entertainment center:

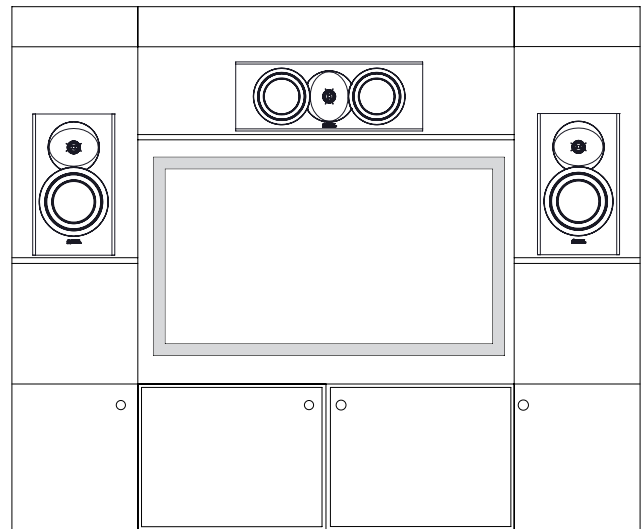

- Make sure that the front of the loudspeaker is flush with the front edge of the mounting shelf and surrounding surfaces.
- If necessary to aim the center channel directly at the listeners' ears, use the supplied feet to angle the loudspeaker at the listeners' ears, see the next page for additional information.

ADJUSTABLE FEET ON C25

C25 loudspeakers include two sets of adjustable feet, one short and one long that let you angle the loudspeaker up or down so it is aiming towards listeners' ears when it is installed above or below a TV display. The feet screw into the threaded inserts on the bottom of the speaker.

- To tilt the loudspeaker upward, install the set of short feet into the front threaded inserts on the bottom of the loudspeaker. Install the long feet on the back so that the loudspeaker achieves a level balance.

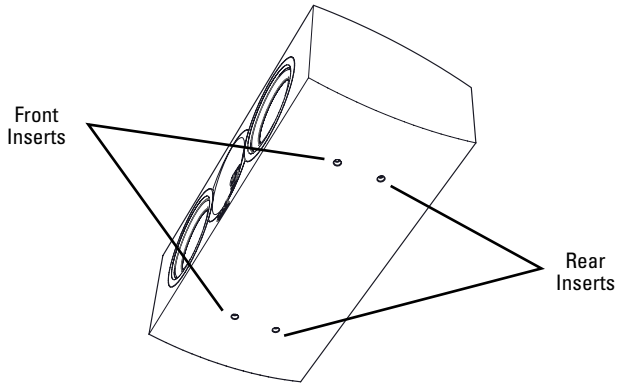

- To aim the loudspeaker straight forward (with no tilt), install the set of short feet into the front threaded inserts on the bottom of the loudspeaker and the long threaded feet on the back inserts. Adjust the feet so that the loudspeaker achieves a level balance.
- To tilt the loudspeaker downward, install the set of long feet into the rear threaded inserts on the bottom of the loudspeaker. Adjust the feet so that the loudspeaker achieves a level balance.

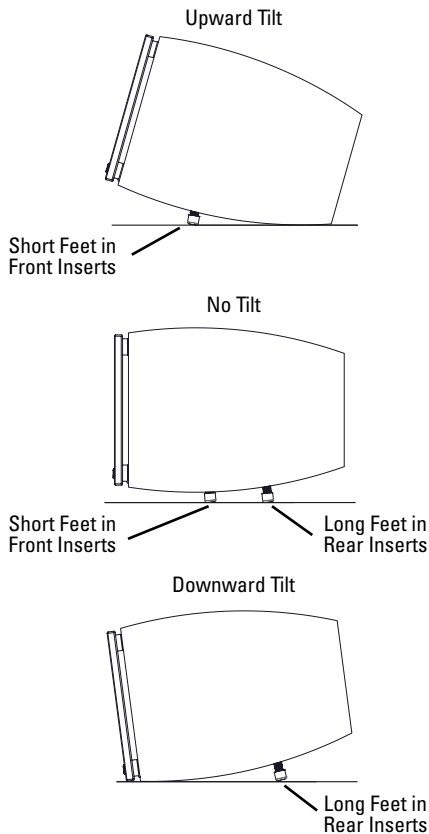

ADJUSTABLE SPIKES ON FLOOR STANDING SPEAKERS

Four adjustable spikes are included for each F35 and F36 loudspeakers. You can install these spikes in the bottoms of the loudspeaker cabinets to provide optimal stability, accommodating installations on tile, hardwood, and carpeted floors.

To install and adjust the spikes:

1. Place the loudspeaker on its side on a soft towel or carpeted floor.
2. Screw the spikes into the fittings on the bottom of the loudspeaker. The spikes can be installed with either the pointed end or round end protruding from the cabinet.
 - If the loudspeakers are to be placed on a carpeted floor, install the spikes with the pointed ends protruding from the cabinet.
 - If the loudspeakers are to be placed on wood, linoleum or tile floor, install the spikes with the round ends protruding from the cabinet. After determining the final locations for the speakers you can place coins under the spikes to protect the floor surface from damage.

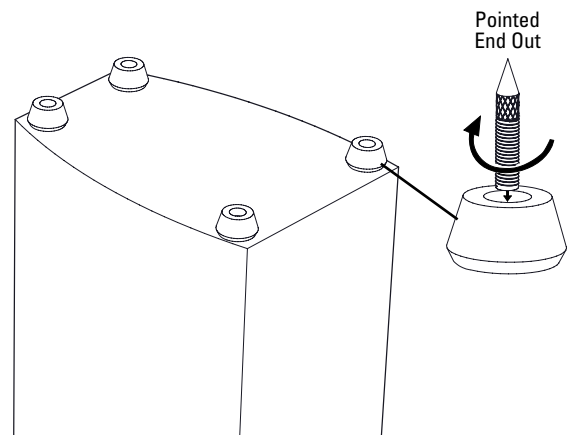

- If you wish you can install the spikes with the pointed ends protruding from the cabinet for placement on wood, linoleum or tile floors. In this case you must place coins or similar items under the spikes to avoid damaging the floor surface.

LOUDSPEAKER PLACEMENT FOR S16

Loudspeaker fidelity depends on the following three factors: loudspeaker accuracy, loudspeaker placement and listening room acoustics. Advanced Revel design features allow the S16 to achieve exceptional acoustical precision, and the ability to seamlessly blend with other Revel Concerta2-series speakers in 5.1- and 7.1-channel systems.

PLACEMENT IN 5.1-CHANNEL SYSTEMS

The most common 5.1-channel home theater system configuration uses a pair of Concerta2 S16 surround loudspeakers, placed on the side walls above the listening area, as shown in the illustration below. The loudspeaker's radiation pattern is optimized for use at 90 degrees to the sides of the primary listening area. This occurs when the loudspeakers are placed along the side walls, directly to the sides of the prime listening position (90 degrees to the prime listeners' ears). The ideal height is located at 10 to 15 degrees above the prime listener's ears.

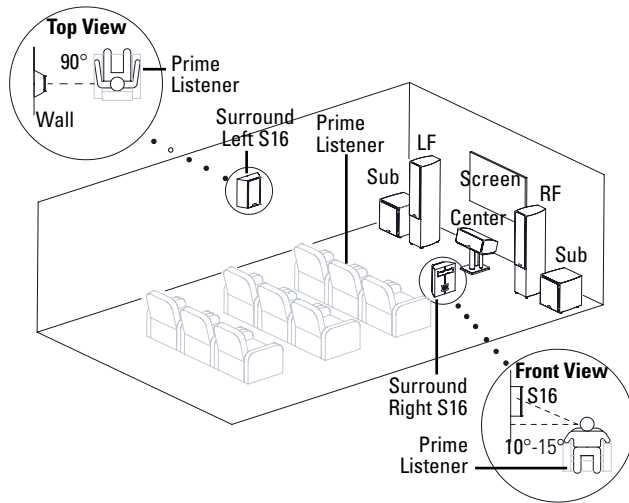

PLACEMENT IN A 7.1-CHANNEL SYSTEM

7.1-Channel surround-sound controllers can independently drive two pairs of surround loudspeakers: a pair of Surround Left/Right speakers and a pair of Surround Back Left/Right speakers.

- The recommended configuration is with the Surround Left and Surround Right S16 loudspeakers placed on the side walls as in a 5.1-channel system, and the Surround Back Left and Surround Back Right S16 loudspeakers placed on the rear wall, as shown in the illustration below.

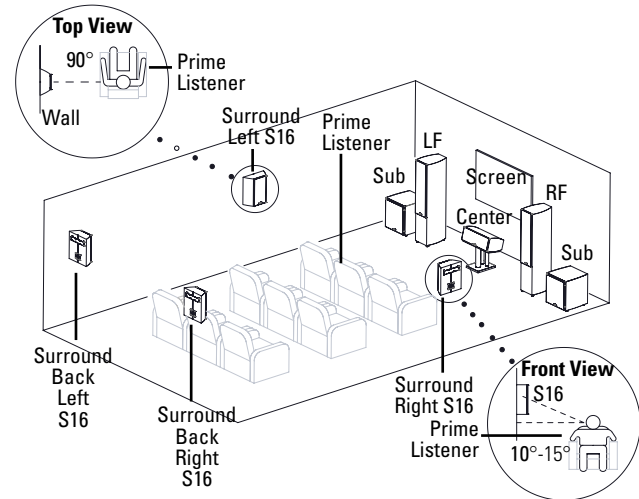

WALL-MOUNTING THE S16

The Concerta2 S16 loudspeakers come with an integral wall mounting system. Built-in mounting keyholes on the rear of the speaker are designed to be used with the supplied wall-mount bracket.

CAUTION: Revel does not supply hardware to mount the supplied bracket on a wall. It is the customer's responsibility to select wall-mounting hardware that is appropriate for their wall's materials and construction. Revel recommends that installation should only be done by qualified individuals who are experienced in affixing and installing wall-mounted electrical equipment, and who understand and observe all relevant safety precautions. HARMAN International Inc. disclaims any liability whatsoever for injury or damage to persons or property arising from installation of its products or use of hardware it provides.

After the bracket is mounted on the wall (check the level of the bracket) and make sure the speaker is connected to the amplifier (see Making Connections), slip the speaker's mounting keyholes over the bracket pegs, as shown in the illustration.

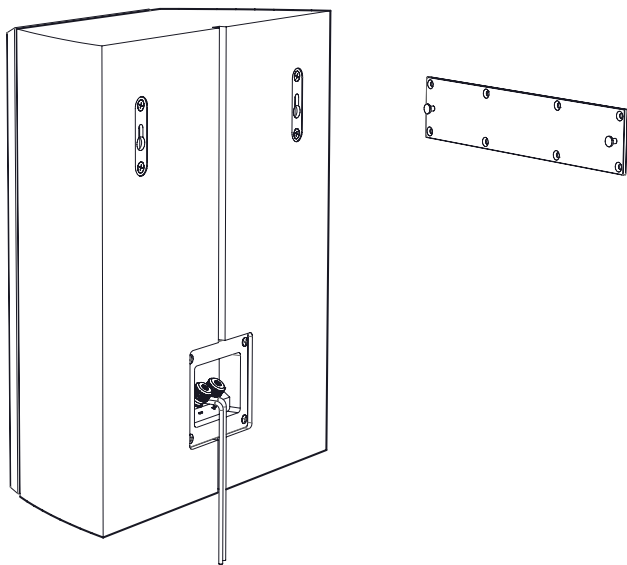

MAKING CONNECTIONS

CAUTION: Never make or break connections unless all system components are powered off.

OBSERVE PROPER POLARITY

Connect the amplifier's positive (+) terminal to the positive (+) terminal on the loudspeaker; connect the amplifier's negative (-) terminal to the negative (-) terminal on the loudspeaker. Do not reverse polarities (that is, do not connect + to -, or - to +) when making connections. Doing so will cause diminished dialog intelligibility and diminished bass response.

CAUTION: Revel M16, C25, and S16 loudspeakers are designed to be used with an external crossover (high-pass filter), such as is found in surround processors and audio/video receivers. An 80Hz crossover frequency is ideal, and will minimize dynamic compression and distortion. If desired, the M16, C25, or S16 may be used with crossover frequencies as low as 50Hz. If the AVR/processor only offers "Large" and "Small" settings select the "Small" setting.

CONNECTIONS

The Concerta2 speakers feature gold-plated binding posts.

WIRED CONNECTION

Single-wired connections are the most common. These are made between one pair of input terminals and one power amplifier output channel as shown below.

To make single-wired connection, connect one loudspeaker cable to the desired set of input terminals. Then connect the other end of that loudspeaker cable to the desired power amplifier output channel.

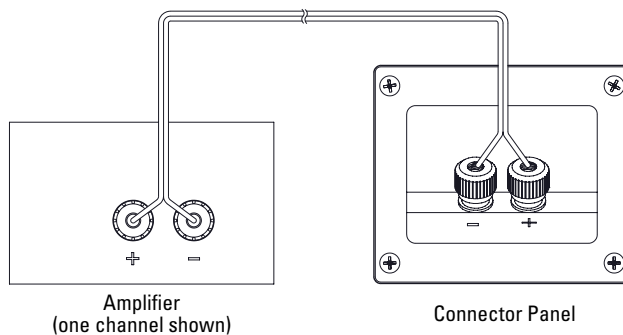

CARING FOR YOUR LOUDSPEAKERS

GRILLES

Revel Concerta2 speakers feature grilles with a magnetic attachment method that eliminates unsightly attachment hardware from the speaker baffle, so if you decide to use your speakers with the grilles removed they will retain their elegant appearance.

CABINET FINISH

The cabinet's finish does not require routine maintenance. Cabinet surfaces that have been marked with dust, fingerprints, or other dirt can be cleaned using a soft cloth – preferably micro-fiber, and high quality auto wax. Take care not to come in contact with the transducers. Use caution to avoid contacting the rubberized trim on the sides of the loudspeaker with auto wax. If necessary, the rubberized trim can be cleaned with denatured alcohol on a microfiber cloth. To clean the grille, gently vacuum it using a soft-bristled brush vacuum attachment with the vacuum cleaner set to the lowest possible suction.

SPECIFICATIONS

MODEL	F36	F35	M16	C25	S16
DESCRIPTION	2.5-way Triple 6.5" Floorstanding Loudspeaker	2.5-way Triple 5.25" Floorstanding Loudspeaker	2-way 6.5" Bookshelf Loudspeaker	2-way Dual 5.25" Center Channel Loudspeaker	2-way 6.5" On-Wall Loudspeaker
ENCLOSURE TYPE	Bass-Reflex via Rear-Firing Port	Bass-Reflex via Rear-Firing Port	Bass-Reflex via Rear-Firing Port	Sealed	Sealed
HF DRIVE COMPONENT	1" Aluminum Tweeter with Acoustic Lens and Waveguide	1" Aluminum Tweeter with Acoustic Lens and Waveguide	1" Aluminum Tweeter with Acoustic Lens and Waveguide	1" Aluminum Tweeter with Acoustic Lens and Waveguide	1" Aluminum Tweeter with Acoustic Lens and Waveguide
LF/MF DRIVE COMPONENTS	3 x 6.5" Aluminum Cone Woofers	3 x 5.25" Aluminum Cone Woofers	6.5" Aluminum Cone Woofer	Dual 5.25" Aluminum Cone Woofers	6.5" Aluminum Cone Woofer
CROSSOVER FREQUENCY	600Hz, 1.8kHz	575Hz, 1.8kHz	2.1kHz	2.1kHz	1.8kHz
SENSITIVITY (2.83V @ 1M)	91dB	90dB	86dB	89dB	90dB
NOMINAL IMPEDANCE	6 Ohms	6 Ohms	6 Ohms	6 Ohms	6 Ohms
RECOMMENDED AMPLIFIER POWER	30-200W	30-180W	50-120W	40-120W	30-120W
LF EXTENSION	51Hz	55Hz	55Hz	80Hz	70Hz
-3 DB	45Hz	46Hz	50Hz	68Hz	58Hz
-6 DB	33Hz	35Hz	45Hz	48Hz	43Hz
-10 DB					
DIMENSIONS (H X W X D)	44.25" x 9.65" x 12"	40.25" x 8.42" x 12.2"	14.75" x 8.6" x 10.76"	7.25" x 19.45" x 10.1"	14.75" x 13.3" x 5.5"
WEIGHT	50 lbs	41 lbs	16 lbs	20 lbs	14 lbs

Торговая марка:	Revel
Назначение товара:	Пассивная акустическая система
Изготовитель:	Харман Интернешнл Индастриз Инкорпорейтед, США, 06901 Коннектикут, г.Стэмфорд, Атлантик Стрит 400, офис 1500
Страна происхождения:	Китай
Импортер в Россию:	ООО Внешторг-Юг, Россия, 171640, Тверская область, г.Кашин, ул. Карла Маркса, д.57А
Гарантийный период:	1 год
Информация о сервисных центрах:	http://absolut-audio.ru/Servis/ тел. +7 (495) 995-10-80
Срок службы:	5 лет
Срок хранения:	не ограничен
Условия хранения:	Стандартные при нормальных значениях климатических факторов внешней среды
Номер документа соответствия:	Товар не подлежит обязательной сертификации
Дата производства:	Дата изготовления устройства определяется по двум буквенным обозначениям из второй группы символов серийного номера изделия, следующих после разделительного знака «-». Кодировка соответствует порядку букв латинского алфавита, начиная с января 2010 года: 000000-МУ0000000, где «М» - месяц производства (А - январь, В - февраль, С - март и т.д.) и «У» - год производства (А - 2010, В - 2011, С - 2012 и т.д.).





HARMAN International, Incorporated
8500 Balboa Boulevard, Northridge, CA 91329 USA

© 2015 HARMAN International, Incorporated. All rights reserved.

Revel and the Revel logo are trademarks of HARMAN International, Incorporated,
registered in the United States and/or other countries.

Features, specifications and appearance are subject to change without notice.

For questions, assistance or additional information concerning any of our products,
call us at: (888) 691-4171. For technical support, submit your detailed inquiry

Part No.950-0516-001 Rev: B



www.revelspeakers.com

