

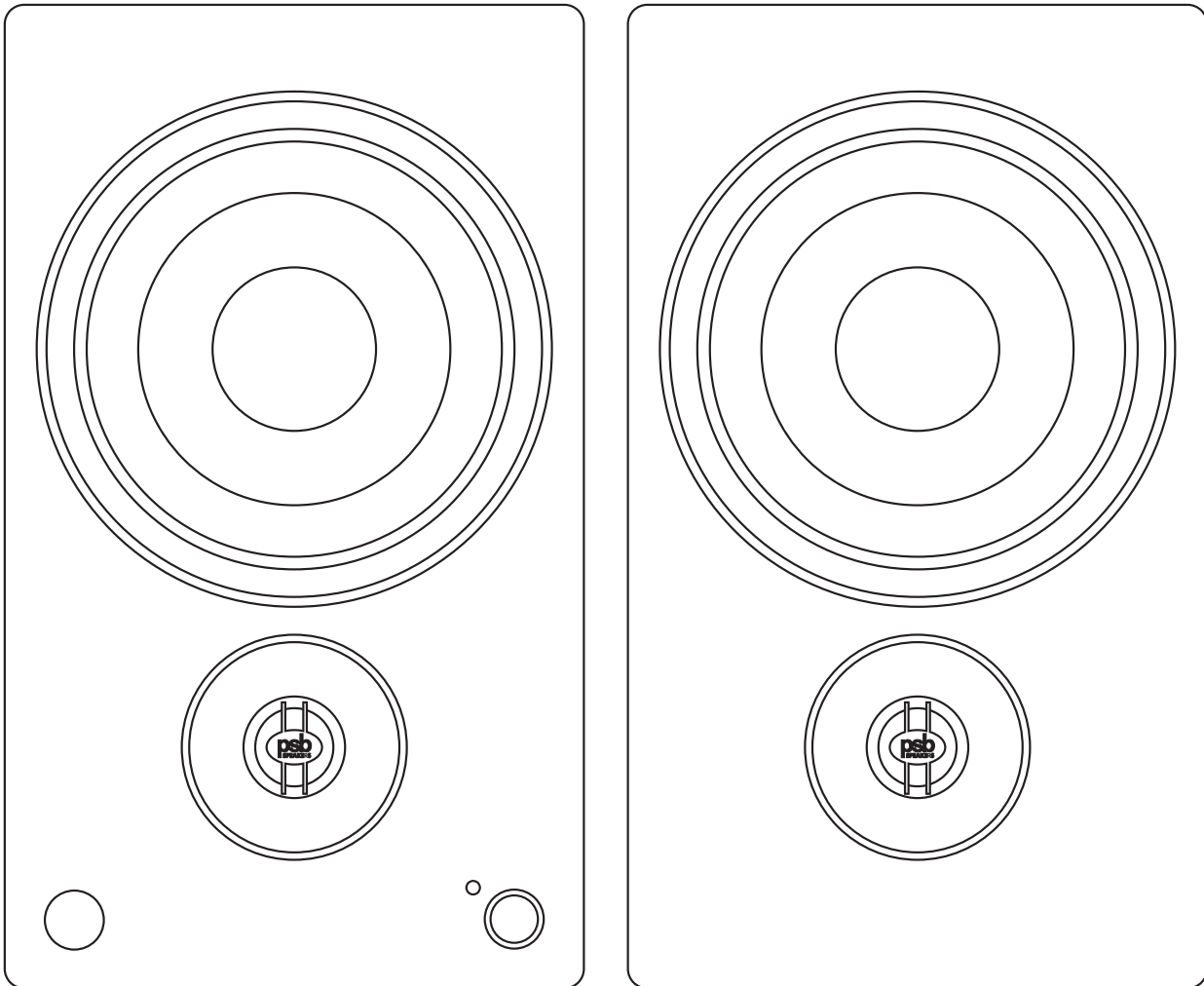

ALPHA AM5

OWNER'S GUIDE



IMPORTANT SAFETY INSTRUCTIONS

1. Read these instructions.
2. Keep these instructions.
3. Heed all warnings.
4. Follow all instructions.
5. Do not use this apparatus near water.
6. Clean only with dry cloth.
7. Do not block any ventilation openings. Install in accordance with the manufacturer's instructions.
8. Do not install near any heat sources such as radiators, heat registers, stoves, or other apparatus (including amplifiers) that produce heat.
9. Do not defeat the safety purpose of the polarized or grounding-type plug. A polarized plug has two blades with one wider than the other. A grounding type plug has two blades and a third grounding prong. The wide blade or the third prong are provided for your safety. If the provided plug does not fit into your outlet, consult an electrician for replacement of the obsolete outlet.
10. Protect the power cord from being walked on or pinched particularly at plugs, convenience receptacles, and the point where they exit from the apparatus.
11. Only use attachments/accessories specified by the manufacturer.
12. Use only with the cart, stand, tripod, bracket, or table specified by the manufacturer, or sold with the apparatus. When a cart is used, use caution when moving the cart/apparatus combination to avoid injury from tip-over. 
13. Unplug this apparatus during lightning storms or when unused for long periods of time.
14. Refer all servicing to qualified service personnel. Servicing is required when the apparatus has been damaged in any way, such as power-supply cord or plug is damaged, liquid has been spilled or objects have fallen into the apparatus, the apparatus has been exposed to rain or moisture, does not operate normally, or has been dropped.
15. The apparatus shall not be exposed to dripping or splashing and that no objects filled with liquids, such as vases, shall be placed on the apparatus.
16. WARNING: To reduce the risk of fire or electric shock, this apparatus should not be exposed to rain or moisture.
17. The mains plug or an appliance coupler is used as the disconnect device, the disconnect device shall remain readily operable.



The lightning flash with arrowhead symbol within an equilateral triangle, is intended to alert you to the presence of uninsulated "dangerous voltage" within the product's enclosure that may be of sufficient magnitude to constitute a risk of electric shock to persons.



The exclamation point within an equilateral triangle is intended to alert you to the presence of important operating and maintenance (servicing) instructions in the literature accompanying the product.

FCC Warnings

This device complies with part 15 of the FCC Rules. Operation is subject to the following two conditions: (1) This device may not cause harmful interference, and (2) this device must accept any interference received, including interference that may cause undesired operation.

Any Changes or modifications not expressly approved by the party responsible for compliance could void the user's authority to operate the equipment.

Note: This equipment has been tested and found to comply with the limits for a Class B digital device, pursuant to part 15 of the FCC Rules. These limits are designed to provide reasonable protection against harmful interference in a residential installation. This equipment generates uses and can radiate radio frequency energy and, if not installed and used in accordance with the instructions, may cause harmful interference to radio communications. However, there is no guarantee that interference will not occur in a particular installation. If this equipment does cause harmful interference to radio or television reception, which can be determined by turning the equipment off and on, the user is encouraged to try to correct the interference by one or more of the following measures:

-Reorient or relocate the receiving antenna.

-Increase the separation between the equipment and receiver.

-Connect the equipment into an outlet on a circuit different from that to which the receiver is connected.

-Consult the dealer or an experienced radio/TV technician for help.

This equipment complies with FCC radiation exposure limits set forth for an uncontrolled environment. This equipment should be installed and operated with minimum distance 20cm between the radiator & your body.

IC WARNING

This radio transmitter has been approved by Industry Canada.

This Class B digital apparatus complies with Canadian standard ICES-003. This device complies with Industry Canada License exempt RSS standard(s). Operation is subject to the following two conditions.

- (1) This device may not cause interference and
- (2) this device must accept any interference, including interference that may cause undesired operation of the device.

This equipment complies with ISED radiation exposure limits set forth for an uncontrolled environment. This equipment should be installed and operated with minimum distance 20cm between the radiator & your body.

Operating Environment Temperature

This product is designed to operate within a temperature range of 0 - 35 degrees Celsius only.

CAUTION

Risk of explosion if the battery is replaced by an incorrect type.

Notes on environmental protection

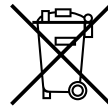

At the end of its useful life, this product must not be disposed of with regular household waste but must be returned to a collection point for the recycling of electrical and electronic equipment. The symbol on the product, user's manual and packaging, point this out.

The materials can be reused in accordance with their markings. Through re-use, recycling of raw materials, or other forms of recycling of old products, you are making an important contribution to the protection of our environment.

Your local administrative office can advise you of the responsible waste disposal point.

Introduction

Thank you for your PSB Speakers purchase. Our wide collection of high-performance loudspeakers, headphones, and home audio products bring music and video collections to life. Producing natural musical dynamics and precise imaged sound, PSB Speakers will simply bring you closer to the music you love.

Alpha stands for the best value in high performance loudspeakers. The Alpha AM5 powered speakers take the Alpha concept to an entirely new level by including a built-in amplifier to create a complete audio solution with enough acoustic output to fill small to medium sized rooms. Based on decades of acoustic research and rigorous testing, the Alpha powered speakers benefit from proven knowledge and techniques, and delivers "true-to-nature" sound quality for today's music enthusiasts and professionals.

By supplying this owner's guide, we hope you will read through this information to help assure that you are getting the most out of your PSB product.

Unpacking

The packing materials are designed to protect the speakers from damage during transport, however if visible or concealed damage is to occur in handling, it should be reported at once to your authorized PSB dealer, or to the shipping company that delivered your loudspeakers. We highly recommend retaining all packaging, as it may be needed to transport the speakers in the future.

The Speakers

- I. Connect the right speaker to the indicated and corresponding speaker binding post of the speaker amplifier using the included speaker cable.
- II. As these speakers are self-powered, do not attempt to connect the supplied cable to the speaker outputs of a stereo receiver.
- III. For improved low frequency response, the Alpha AM5 powered speakers are equipped with a sub out connection for adding a powered subwoofer, if needed.

Front of the Amplified Speaker

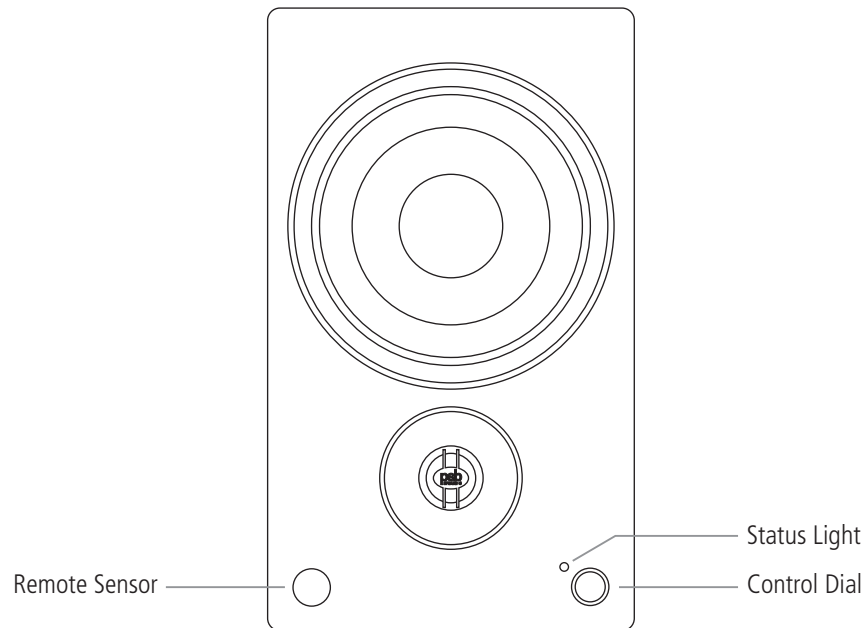

Status Light: Displays different colours to show:

- which source is playing
- a listening mode is chosen
- maximum and minimum volume, bass and treble controls
- Bluetooth pairing mode

Control Dial: Turn: to adjust the volume
Press: to change the input

Remote Sensor: Point the remote control at the remote sensor and press the buttons. Do not expose the remote sensor of the speaker to light source such as direct sunlight or illumination. If you do so, you may not be able to operate the speaker with the remote control.

Changing the Brightness of the Status Light

The status light has 3 levels of brightness. High/Low/Off. The speakers will arrive with the brightness level set at High.

- I. To change the brightness, hold the SUB button on the remote control for 5 seconds. The brightness level will change to Low.
- II. When the brightness level is set to Low, hold the SUB button on the remote control for 5 seconds; the status light will slowly turn Off.
- III. Repeat the process and the status light will be set at High again.

Note: When the status light is set to Off, the following will occur:

When turning on the speakers, the brightness will be on High for 3 seconds then slowly turn Off.

To change any function, press any button to activate the status light, then change the function.
After the change has occurred, the status light will return to Off.

Back Panel of the Amplified Speaker

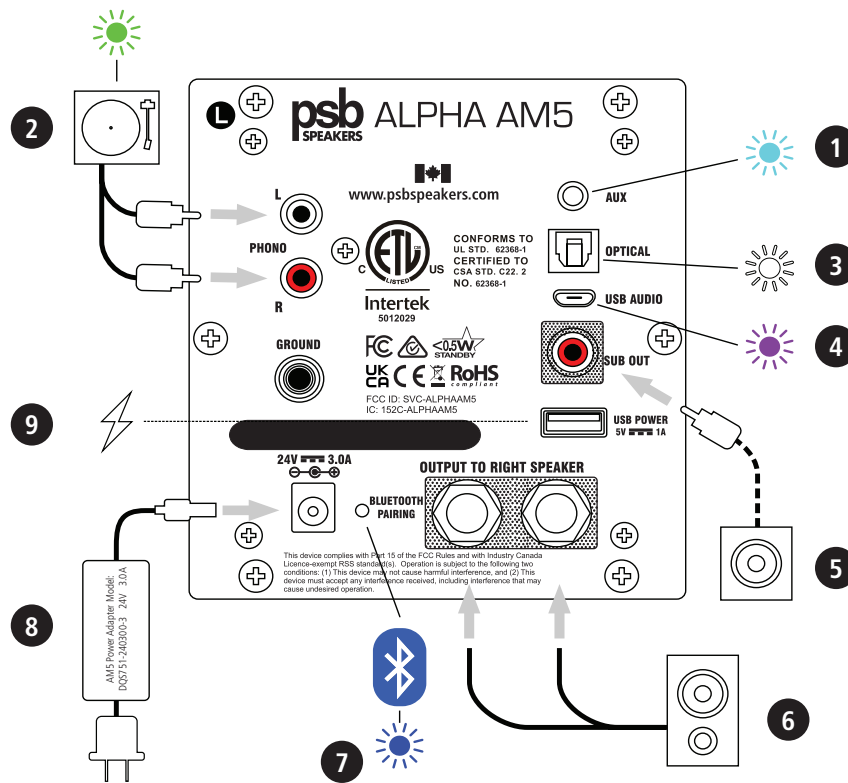

- 1) **Analogue Input (Auxiliary)**
Using the supplied 1/8" (3.5mm) connection cable, connect one end to the speaker AUX input, and the opposite end to the selected audio source. Cyan status light.
- 2) **Phono Input**
Using RCA cables, connect one end to the phono input. Connect the phono ground cable. Green status light.
- 3) **Optical Input (Digital)**
For connecting sources with optical output using an optical interconnect (Toslink). This is a connection which is commonly found on televisions or set top boxes. Connect the optical interconnect from the media source output to the input marked OPTICAL on the AM5. White status light.
- 4) **USB Audio Input**
This connection is best used with a common computer. Use a standard USB cable between the speaker and a USB connection on your computer. Note: Thumb Drives or other storage devices cannot be connected to this input. Purple status light.
- 5) **SUB OUT - Low Pass Filtered Output (Mono)**
For connecting an external active subwoofer.
Subwoofer output can be activated using the supplied remote control, which will also redirect part of the low frequency content to the subwoofer. Connect the Alpha AM5 to the low-level input of the external subwoofer using a subwoofer interconnect cable.
- 6) **Speaker Out binding posts:** Connect to the speaker posts of the right speaker with the speaker cable.
- 7) **Bluetooth Pairing Reset Button:** Pressing this button while Bluetooth is in use, will disconnect the current bluetooth device, and allow another bluetooth device to be paired and connected.
- 8) **Power Inlet:** For connecting the unit to included external power supply.
- 9) **USB power port:** The AM5 includes a 5V, 1A USB connection. The USB port is for power and charging, not for data transfer or music playback/streaming.

Remote Control

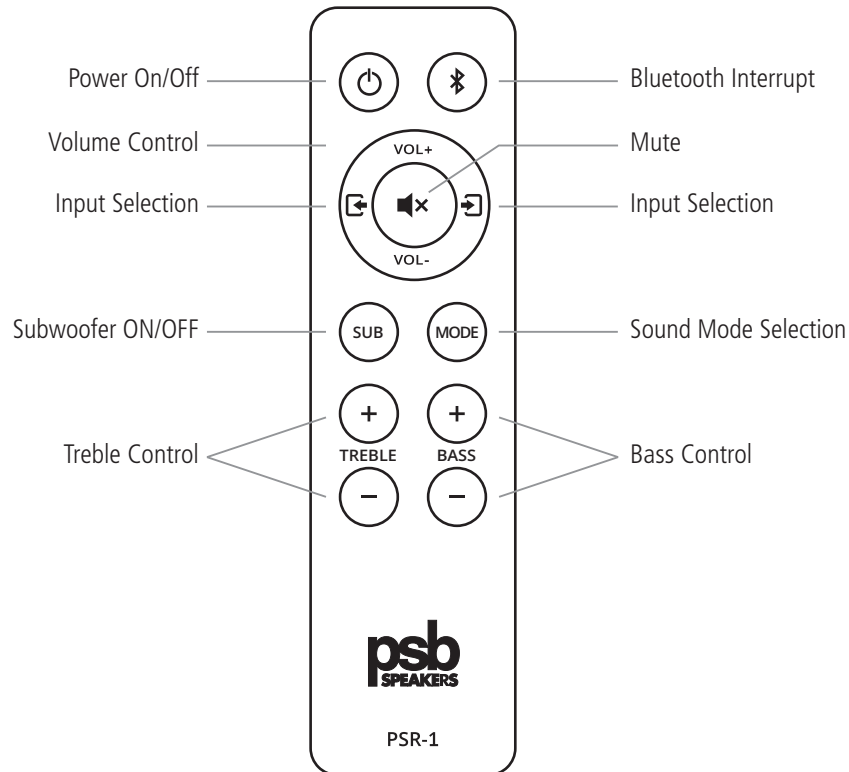

Install the supplied two AAA batteries into the remote control. Be careful to ensure that it is correctly inserted according to the polarity (+/-). You should only use the battery specified for this system. Caution: When replacing the batteries, ensure that you only use standard AAA batteries which are not rechargeable. The use of an incorrect type of battery may cause severe damage to the remote or risk explosion.

- 1. On/Off:** Speakers from standby mode to operating mode. The LED on the front will indicate the colour of the source last chosen.
- 2. Volume Control +/-:** Increase or decrease audio level. Release mute function.
- 3. Input Selection:** Toggle and select source. The LED on the front of the left speaker will change colour, based on the active source:

Analog:	Cyan
Phono:	Green
USB:	Purple
Optical:	White
Bluetooth:	Blue
- 4. Mute:** Temporarily mute audio output or restore audio output from mute.
- 5. Listening Mode Selection:** Press the **"MODE"** button on the remote control once to activate the display and cycle through the four listening modes.

Mode	Effect	Colour
Stereo	Normal	No Colour
Widesound	Expanded Soundstage	Green
Dialogue	Enhanced Dialogue Clarity	Amber
WideSound™ Plus	Expanded Soundstage with Enhanced Dialogue Clarity	Blue

- 6. Subwoofer On/Off:** Subwoofer output can be activated using the supplied remote control, which will also redirect part of the low frequency content to the subwoofer.

7. **Bass Control:** Controls the amount of bass for your listening preference. When initially activated, the bass will be set to neutral, or halfway in the range.
8. **Treble Control:** Controls the amount of treble for your listening preference. When initially activated, the bass will be set to neutral, or halfway in the range.

Note: When adjusting the Bass or Treble the status light will make a single red flash to show that the midpoint of the level has been reached. If you have reached the maximum or minimum level of the Bass or Treble, the status light will flash every time you press the button to indicate that you have reached the limit.

9. **Bluetooth Interrupt:** Holding this button for 3 seconds will disconnect the current Bluetooth device. It will allow another device to be paired or connected.
10. **Sample Rate:** Manually switching between 44.1k and 48k sample rate settings can be achieved by:
 - Holding the Left INPUT SELECTION button for 5 seconds will set the amplifier sample rate to 44.1k. The Status LED should flash Green twice.
 - Holding the Right INPUT SELECTION button for 5 seconds will set the amplifier sample rate to 48k. The Status LED should flash Blue twice.

Infrared Learning

Infrared (IR) Learning enables any non-PSB remote controls learn IR control codes based on the supplied PSB PSR-1 remote control. The functions Power ON/OFF, Volume UP/DOWN, Input Selection and Mute can be learned. With the learned codes, the configured non-PSB remote control can be used to command or operate PSB AM5.

How To Learn IR Remote Control Codes

- I. Hold MUTE button for 5 seconds to enable the IR learning feature. The Status Light on the front of the powered speaker will flash Red and White.
- II. Press the function/button, POWER ON for example, to be learned from PSB PSR-1 remote control. Status Light flashes Blue twice to show received command, then change to solid Blue.
- III. Press the corresponding button on the non-PSB remote control where POWER ON will be learned. Status Light flashes Green twice to indicate that function/command has been learned.
- IV. Repeat Step 2-3 to learn Power OFF, Volume UP/DOWN, Input Selection and Mute.

Note: IR learning setup times out after 10 seconds of inactivity.

How to Pair with a Bluetooth-Enabled Device

- I. Using the input selections buttons on the remote control, toggle between sources and switch to the BT input (Blue). LED will flash blue-red for two minutes while in Discovery Mode.
- II. Open the Bluetooth settings on your mobile device and start searching for the unique device ID of the AM5.
- III. Once paired, the LED will be illuminated solid Blue to indicate a successful pairing. Start playback of Bluetooth device upon successful pairing.
- IV. If the pairing connection fails, the LED will be solid Red. Repeat the above steps with the remote control and your mobile device to try connecting again.

Using a Bluetooth-enabled Device

- I. Cycle through inputs and select BT to activate Bluetooth discovery. Bluetooth device that was last paired to the AM5 will connect automatically when Bluetooth is switched on and the front panel Bluetooth LED is Blue.
- II. Start playback on your mobile device and the sound will automatically start to play.

How to Disable Bluetooth Audio Playback

- I. Use the input selections buttons on the remote control to switch to one of the other sources (Analogue, Phono, USB or Optical).
- II. Open the Bluetooth settings on your mobile device and turn off the Bluetooth connection or "unpair" the device from the Alpha AM5. The active Bluetooth device can be disconnected by pressing the Bluetooth button on the remote control for 3 seconds. The active Bluetooth stream can also be disconnected by pressing the Bluetooth interrupt button on the back of the left speaker.

Auto Standby

The AM5 will automatically go to standby mode if there is no user interface interaction and no active source input within 20 minutes.

Optical and Analogue Sources

- I. With the optical or analogue source selected, the AM5 will automatically go to standby mode and lower the power consumption to <0.5W, if there is no user interface interaction and no active source input within 20 minutes.
- II. The status light will change to Amber to indicate this.
- III. To wake up the AM5, press "ON" on the remote control.

Bluetooth Source

- I. With an active Bluetooth connection, the AM5 will automatically go into standby mode and lower the power consumption to <0.5W, if the device's audio streaming has stopped for over 20 minutes.
- II. Status LED will change from Blue to Amber.
- III. To wake up the AM5 for Bluetooth listening, press "ON" on the remote control to reactivate Bluetooth Discovery Mode.
- IV. At this point a previously paired device (remembers up to 3 devices), if within range, can immediately start streaming audio. For connecting a new device, follow the Bluetooth pairing instructions in this manual.

Positioning

- I. As symmetrically as possible, place your Alpha AM5 Powered Speakers at a comfortable listening location with no obstructions at the front or back.
- II. We recommend at least three inches of clearance around the back of both speakers. Good air circulation is required for heat dissipation, and to ensure proper performance of the rear-firing ports. Similar positioning and clearance should be used for both speakers.

For more detailed information about speaker placement, please visit www.psbSpeakers.com.

Troubleshooting

Issue

- | | |
|-----------------------------|---|
| Audible Distortion | I. If a speaker begins to sound distorted or fatigued, check to see whether playing at a lower volume resolves this issue. |
| Low or No Volume Output | I. If there is low or no volume output, check that the audio source is powered "ON", and that the audio is set to a medium volume level and not muted.
II. If audio source is indeed powered "ON", check and ensure that the cable connection to the audio source is properly secured, or try a different cable. |
| No Sound from Right Speaker | I. If there is volume output from only the left channel, check that the cable connection is properly secured, and connected to the corresponding output jacks on both speakers. |

Protecting your Investment

For long lasting enjoyment of your PSB product, you should respect their limits and avoid excessive volume levels for music or movie playback. Excessive volume levels can damage all types of speakers. If your speakers are pushed to excessive volume levels, they could be driven into "clipping", which may result in severe and/or permanent damage.

If listening to your speakers at loud levels, listen carefully for any signs of harsh, distorted midrange and diminishing precision. If detected, turn the volume down immediately.

NEVER TEST PEAK LISTENING LEVELS OF YOUR SPEAKERS BY TURNING THE VOLUME TO THE MAXIMUM LEVEL.

Care and Cleaning

For safe, sanitary use, it is essential to maintain and clean your speakers periodically. However, excessive cleaning may cause damage and jeopardize the longevity of the product. When not in use, avoid storing in extreme hot or cold temperatures and humidity, and avoid exposure to liquids.

Packaging

We highly recommend retaining all product packaging for any necessary transporting. To transport, carefully place the speakers into their original packaging and close each panel.

Cabinet Care

PSB cabinets have varying materials and finishes, including wood veneers, vinyl, anodized aluminum, and high gloss, and should be treated with the same care you would with similar finishes such as on furniture. Dust lightly with a soft cloth, avoiding abrasive materials that will cause permanent damage to the cabinet. If necessary, wipe carefully with a cloth slightly dampened with water-based cleaner to remove heavy soil.

Drivers and Port Care

During light cleaning, avoid touching speaker diaphragms as it could cause permanent damage to the tweeter and/or drivers. To clean the driver ports, we suggest using a lint-free cloth.

Specifications

FREQUENCY RESPONSE

On Axis @ 0° ± 3dB 55Hz-20Khz
LF Cutoff -10dB 36Hz

AMPLIFIER POWER

50 watts x 2 RMS

ACOUSTIC DESIGN

Tweeter (Nominal) 3/4" (19mm) Aluminium Dome
with Ferrofluid and Neodymium Magnet

Woofer (Nominal) 5.25" (133mm) Cone Rubber Surround Steel Basket

INPUTS

Analog 3.5mm, Phono MM
Digital Optical, USB
Wireless aptX™ Bluetooth
Design Type Bass Reflex

CONSTRUCTION

Cabinet MDF
Cabinet Sleeve Vinyl
Baffle Front MDF
Grille Perforated Metal

SIZE (W x H x D)

Net Dimensions (Gross Dimensions)
6 3/4" x 11 2/5" x 9 1/2"
(170 x 290 x 240mm)

Net Weight 21.5 lbs (9.75 kg) /pair

Shipping Dimensions 18 3/8" x 13 3/8" x 15"
(467 x 340 x 381mm)

Shipping Weight 23.6 lbs (10.71 kg) /pr

FINISH

Matte Black, Matte White

CONTENTS

Speakers
Remote Control
16 Gauge Speaker Cable
3.5mm Analog Audio Cable

