



HOSHIZAKI

Instruction Manual

Modular Crescent Cuber

Models

KM-830MAK2



hoshizakiamerica.com

Issued: 3-31-2026

⚠ WARNING

Only qualified service technicians should install and service the appliance. To obtain the name and phone number of your local Hoshizaki Certified Service Representative, visit www.hoshizakiamerica.com. No installation, operation, maintenance, or service should be undertaken until the technician has thoroughly read this Instruction Manual. No service should be undertaken until the technician has thoroughly read the service manual available at www.hoshizakiamerica.com. Likewise, the owner/manager should not proceed to operate the appliance until the installer has instructed them on its proper operation. Failure to install, operate, and maintain the appliance in accordance with this manual will adversely affect safety, performance, component life, and warranty coverage and may result in costly water damage. Proper installation is the responsibility of the installer. Product failure or property damage due to improper installation is not covered under warranty.

Hoshizaki provides this manual primarily to assist qualified service technicians in the installation, operation, maintenance, and service of the appliance.

Should the reader have any questions or concerns which have not been satisfactorily addressed, please call, send an e-mail message, or write to the Hoshizaki Technical Support Department for assistance.

Phone: 1-800-233-1940; (770) 487-2331

E-mail: tech-support@hoshizaki.com

HOSHIZAKI AMERICA, INC.

618 Highway 74 South
Peachtree City, GA 30269
Attn: Hoshizaki Technical Support Department

NOTE: To expedite assistance, all correspondence/communication **MUST** include the following information:

- Model Number _____
- Serial Number _____
- Complete and detailed explanation of the problem.

IMPORTANT

This manual should be read carefully before the appliance is installed and operated. Read the warnings and guidelines contained in this manual carefully as they provide essential information for the continued safe use and maintenance of the appliance. Retain this manual for any further reference that may be necessary.

CONTENTS

Important Safety Information	4
I. Specifications.....	9
A. Electrical and Refrigerant Data	9
B. Dimensions/Connections	10
II. Installation Instructions	11
A. Location	12
B. Checks Before Installation.....	13
C. How to Remove Panels	14
D. Dispenser Unit/Ice Storage Bin and Icemaker Setup	15
E. Electrical Connection	16
F. Water Supply and Drain Connections	17
G. Final Checklist	19
1. Pre-Startup	19
2. Post-Startup.....	19
III. Operating Instructions.....	20
A. Important Notes About Usage.....	20
B. Startup	21
C. Alarm Safeties	23
IV. Maintenance	24
A. User Maintenance Schedule	24
B. Service Maintenance Schedule.....	25
C. Cleaning and Sanitizing Instructions.....	26
V. Preparing the Appliance for Periods of Non-Use	28
VI. Decommissioning and Disposal	30

Important Safety Information

Throughout this manual, notices appear to bring your attention to situations which could result in death, serious injury, damage to the appliance, or damage to property.

	R-290 Class A3 Flammable Refrigerant Used	
⚠ DANGER	Indicates a hazardous situation that, if not avoided, will result in death or serious injury.	
⚠ WARNING	Indicates a hazardous situation that, if not avoided, could result in death or serious injury.	
NOTICE	Indicates a situation that, if not avoided, could result in damage to the appliance or property.	
IMPORTANT	Indicates important information about the use and care of the appliance.	
⚠ DANGER		
<p><u>Risk of Fire or Explosion</u> <u>Flammable Refrigerant Used</u></p> <ul style="list-style-type: none"> • Only qualified service technicians should install and service the appliance. • No installation, operation, or maintenance should be undertaken until the technician has thoroughly read this Instruction Manual. All safety precautions must be followed. • No service should be undertaken until the technician has thoroughly read the Service Manual available at www.hoshizakiamerica.com. All safety precautions must be followed. • This appliance to be installed in accordance with the Safety Standard for Refrigeration Systems ANSI/ASHRAE 15. • Follow handling instructions carefully in compliance with national regulations. • Do not use mechanical devices or other means to accelerate the defrosting process or to clean, other than those recommended by the manufacturer. • Do not puncture refrigerant tubing. Risk of fire or explosion due to puncture of refrigerant tubing; follow handling instructions carefully. 	<ul style="list-style-type: none"> • Servicing shall be done by trained service personnel with certified competence in handling flammable refrigerants to minimize the risk of possible ignition due to incorrect parts or improper service. • Component parts shall be replaced with like components. So as to minimize the risk of possible ignition due to incorrect parts. • Dispose of properly in accordance with federal or local regulations. • Do not pierce or burn. • Be aware that refrigerants may not contain an odor. • Do not damage the refrigeration circuit. • See nameplate for R-290 refrigerant charge: <ul style="list-style-type: none"> • If greater than 114 g (4 oz.), do not install in public corridor or lobby. • If greater than 152 g (5.3 oz.), do not install within 6 m (20 ft) of open flame. • The appliance shall be stored in a room without continuously operating ignition sources (for example: open flames, an operating gas appliance, or an operating electric heater). 	

⚠ DANGER continued

- Do not place any potential ignition sources in or near the appliance.
- Keep clear of obstruction all ventilation openings in the appliance enclosure or in the structure for building-in.
- No potential sources of ignition are to be used in the searching for or detection of refrigerant leaks.
- Do not use electrical appliances inside the appliance unless they are of the type recommended by the manufacturer.
- Do not store explosive substances such as aerosol cans with a flammable propellant in this appliance.
- Check that cabling will not be subject to wear, corrosion, excessive pressure, vibration, sharp edges, or any other adverse environmental effects. The check shall also take into account the effects of aging or continual vibration from sources such as compressors or fans.
- Ensure that the area is in the open or that it is adequately ventilated before breaking into the system or conducting any hot work. A degree of ventilation shall continue during the period that the work is carried out. The ventilation should safely disperse any released refrigerant and preferably expel it externally into the atmosphere.
- This appliance should only be used on an ice storage bin/dispenser unit without electrical components or one designed to be used with flammable refrigerants.

Risque D'Incendie ou D'Explosion Fluide Frigorigène Inflammable Utilisé

- Seuls des techniciens de service qualifiés doivent installer et entretenir l'appareil.
- Aucune installation, opération ou maintenance ne doit être entreprise avant que le technicien n'ait lu attentivement ce manuel d'instructions. Toutes les précautions de sécurité doivent être suivies.
- Aucune opération d'entretien ne doit être entreprise avant que le technicien n'ait lu attentivement le manuel d'entretien disponible sur le site www.hoshizakiamerica.com. Toutes les précautions de sécurité doivent être suivies.
- Cet appareil doit être installé conformément à la norme de sécurité pour les systèmes de réfrigération ANSI/ASHRAE 15.
- Suivez attentivement les instructions de manutention conformément aux règlements nationaux.
- Ne pas utiliser de dispositifs mécaniques ou d'autres moyens pour accélérer le processus de dégivrage ou pour nettoyer, autres que ceux recommandés par le fabricant.
- Ne pas perforer la conduite de fluide frigorigène. Risque d'incendie ou d'explosion en cas de perforation d'une canalisation de fluide frigorigène; suivez attentivement les instructions de manutention.
- L'entretien doit être effectué par du personnel formé et certifié pour la manipulation de réfrigérants inflammables afin de réduire au minimum le risque d'inflammation dû à des pièces incorrectes ou à un entretien inadéquat.

DANGER Continu 

- Les pi ces doivent  tre remplac es par des pi ces similaires, de mani re   r duire au minimum le risque d'inflammation d    des pi ces incorrectes.
 - Mettre au rebut conform ment aux r glementations f d rales ou locales.
 - Ne pas percer ou br ler.
 - Attention, les fluides frigorig nes peuvent ne pas d gager d'odeur.
 - Ne pas endommager les composants du circuit de r frig ration.
 - Voir plaque signal tique pour la charge de r frig rant R-290:
 - Si elle est sup rieure   114 g (4 oz.), ne pas l'installer dans un couloir public ou un hall d'entr e.
 - Si elle est sup rieure   152 g (5.3 oz.), ne pas l'installer   moins de 6 m (20 pi) d'une flamme nue.
 - L'appareil doit  tre entrepos  dans un local ne contenant pas de sources d'inflammation permanentes (flammes nues, appareil   gaz ou dispositif de chauffage  lectrique en fonctionnement, par exemple).
 - Ne placer aucune source d'inflammation potentielle   l'int rieur ou   proximit  de l'appareil.
 - Ne pas obstruer les ouvertures de ventilation dans l'enceinte de l'appareil ou dans la structure d'encastrement.
 - Aucune source potentielle d'inflammation ne doit  tre utilis e pour rechercher ou d tecter des fuites de r frig rant.
 - Ne pas utiliser d'appareils  lectriques   l'int rieur de l'appareil, sauf s'ils sont du type recommand  par le fabricant.
 - Ne pas entreposer dans cet appareil des substances explosives telles que des bombes  rosols contenant un gaz propulseur inflammable.
- V rifier que le c blage ne sera pas soumis   l'usure,   la corrosion,   une pression excessive,   des vibrations,   des ar tes vives ou   tout autre effet environnemental n gatif. Le contr le doit  galement prendre en compte les effets du vieillissement ou des vibrations continues provenant de sources telles que les compresseurs ou les ventilateurs.
 - S'assurer que la zone est   l'air libre ou qu'elle est correctement ventil e avant de p n trer dans le syst me ou d'effectuer un travail   chaud. Une certaine ventilation doit  tre maintenue pendant la dur e des travaux. La ventilation doit permettre de disperser en toute s curit  tout r frig rant lib r  et, de pr f rence, de l'expulser dans l'atmosph re.
 - Cet appareil doit  tre utilis  sur un distributeur/bac de stockage   glace sans composants  lectriques ou con u pour  tre utilis  avec des r frig rants inflammables, et d'une taille ou d'un type conforme aux indications de ce manuel.

WARNING

The appliance should be destined only to the use for which it has been expressly conceived. Any other use should be considered improper and therefore dangerous. The manufacturer cannot be held responsible for injury or damage resulting from improper, incorrect, and unreasonable use. Failure to install, operate, and maintain the appliance in accordance with this manual will adversely affect safety, performance, component life, and warranty coverage and may result in costly water damage. **To reduce the risk of death, electric shock, serious injury, or fire, follow basic precautions including the following:**

- This appliance is intended for use at altitudes up to 7,000 m (22,965 ft).
- Wear appropriate personal protective equipment (PPE) when servicing the appliance.
- The appliance must be installed in accordance with applicable national, state, and local codes and regulations.
- The appliance requires an independent power supply of proper capacity. See the nameplate for electrical specifications. Failure to use an independent power supply of proper capacity can result in a tripped breaker, blown fuse, damage to existing wiring, or component failure. This could lead to heat generation or fire.
- Do not make any alterations to the appliance. Alterations could result in electric shock, injury, fire, or damage to the appliance.
- Appliance is heavy. Use care when lifting or positioning. Work in pairs when needed to prevent injury or damage.

- **THE APPLIANCE MUST BE GROUNDED.** Failure to properly ground the icemaker could result in death or serious injury.
- Electrical connection must be hard-wired and must meet national, state, and local electrical code requirements. Failure to meet these code requirements could result in death, electric shock, serious injury, fire, or damage.
- Move the control switch to the "OFF" position and turn off the power supply before servicing. Lockout/Tagout to prevent the power supply from being turned back on inadvertently.
- To reduce the risk of electric shock, do not touch the control switch or mode switch with damp hands.

⚠ WARNING continued

- The appliance is not intended for use by persons (including children) with reduced physical, sensory, or mental capabilities, or lack of experience and knowledge, unless they have been given supervision or instruction concerning use of the appliance by a person responsible for their safety.
- Do not splash, pour, or spray water directly onto or into the appliance. This might cause short circuit, electric shock, corrosion, or failure.
- Children should be supervised to ensure that they do not play with the appliance.
- Do not climb, stand, or hang on the appliance or allow children or animals to do so. Serious injury could occur or the appliance could be damaged.
- Do not use combustible spray or place volatile or flammable substances in or near the appliance. They might catch fire.
- Keep the area around the appliance clean. Dirt, dust, or insects in the appliance could cause harm to individuals or damage to the appliance.

NOTICE

- Follow the water supply, drain connection, and maintenance instructions carefully to reduce the risk of costly water damage.
- In areas where water damage is a concern, install in a contained area with a floor drain.
- Install the appliance in a location that stays above freezing. Normal operating ambient temperature must be within 45°F to 100°F (7°C to 38°C).
- Level the ice dispenser/ice storage bin prior to installing the icemaker. After icemaker installation, confirm the icemaker is level. An out-of-level icemaker could result in improper operation, poor performance, and/or damage to the icemaker.
- Do not leave the appliance on during extended periods of non-use, extended absences, or in sub-freezing temperatures. To properly prepare the appliance for these occasions, follow the instructions in "V. Preparing the Appliance for Periods of Non-Use."
- If water collects in the bin and will not drain, turn off the appliance and close the water supply line shut-off valve. Call for service.
- Do not place objects on top of the appliance.
- The dispenser unit/ice storage bin is for ice use only. Do not store anything else in the dispenser unit/ice storage bin.
- Protect the floor when moving the appliance to prevent damage to the floor.

I. Specifications

A. Electrical and Refrigerant Data

The rating label and nameplate provide electrical and refrigerant data and Year of Manufacture (YOM). The rating label can be seen by removing the front panel.

The nameplate is located on the rear panel. For certification marks, see the nameplate.

We reserve the right to make changes in specifications and design without prior notice.

Model Number	KM-830MAK2
AC SUPPLY VOLTAGE	~208-230/60/1
COMPRESSOR	208-230V 5.3RLA 35LRA
PUMP	120V 1.2FLA 60W
FAN	115-120V 0.9FLA 1/15 HP
OTHER	115-120V 0.3A
MAXIMUM FUSE SIZE	20 AMPS
MAX. HACR BREAKER (USA ONLY)	20 AMPS
MAX. CIRCUIT BREAKER (CANADA ONLY)	20 AMPS
MINIMUM CIRCUIT AMPACITY	20 AMPS
DESIGN PRESSURE kPa (PSI)	HI-2730 (396) LO-1311 (190)
REFRIGERANT g (oz.)	R-290 309 (10.9)
CLIMATIC CLASS	5
INSULATION BLOWING GAS	HFO 1233zd(E)
MINIMUM ROOM FLOOR AREA m ² (ft ²)	14.8 (159.1)
HARVEST RATE	≤1,000 LB/DAY (BATCH)

Note: Climatic Class 5: This appliance electrical safety tested for operation in maximum ambient temperature of 104°F (40°C) with 40% relative humidity. However, normal operating ambient temperature must be within 45°F to 100°F (7°C to 38°C); Normal operating water temperature must be within 45°F to 90°F (7°C to 32°C). Operation of the appliance, for extended periods, outside of these normal temperature ranges may affect appliance performance.

B. Dimensions/Connections

1. Air-Cooled Models (KM-830MAK2)

Units: mm [in.]

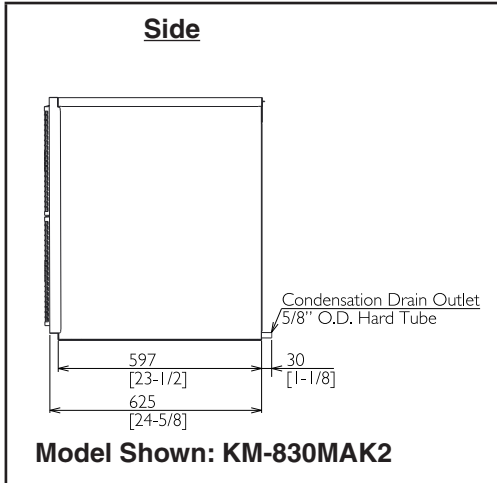

	KM-830MAK2
A	768 [30-1/4]
B	762 [30]
C	80 [3-1/8]
D	713 [28-1/8]
E	662 [26-1/8]
F	660 [26]
G	170 [6-3/4]
H	28 [1-1/8]
I	14 [1/2]
J	499 [19-5/8]

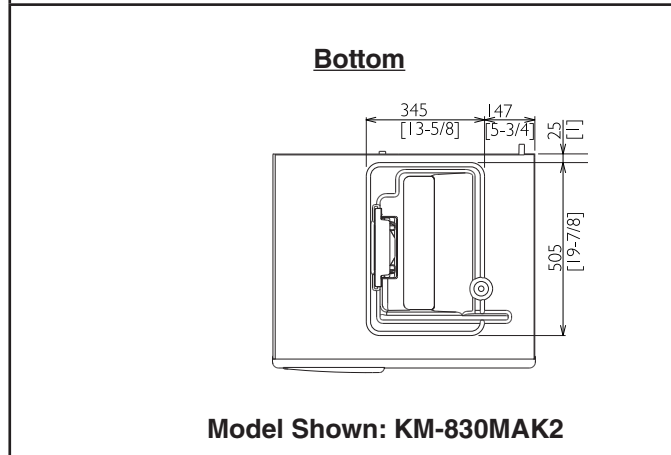
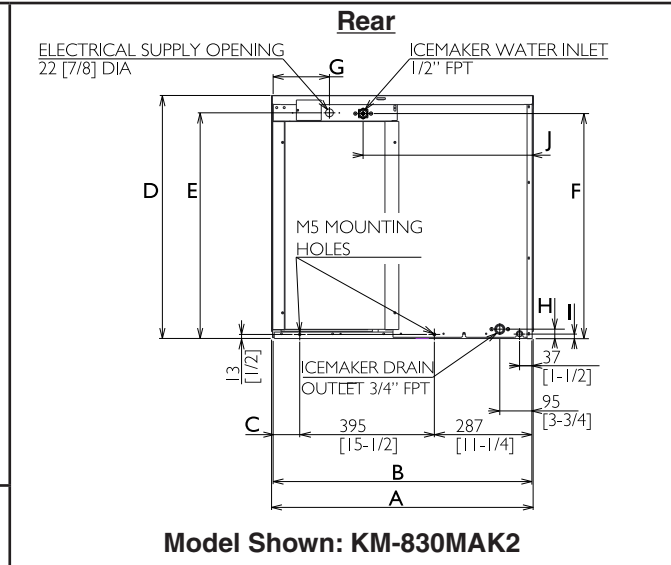

NOTICE

- Allow 6" (15 cm) clearance at rear, sides, and top for proper air circulation and ease of maintenance and/or service should they be required.
- The ice storage bin opening must match the bottom opening as in the illustration.

II. Installation Instructions



WARNING

- This appliance must be installed in accordance with applicable national, state, and local codes and regulations.
- This appliance to be installed in accordance with the Safety Standard for Refrigeration Systems ANSI/ASHRAE 15.
- Failure to install, operate, and maintain the appliance in accordance with this manual will adversely affect safety, performance, component life, and warranty coverage and may result in costly water damage.
- **CHOKING HAZARD:** Ensure all components, fasteners, and thumbscrews are securely in place after installation. Make sure that none have fallen into the ice storage bin.

A. Location

1. General

This appliance uses an A3 flammable refrigerant. For refrigerant charge and minimum room floor area, see the table below.

⚠ DANGER		
	R-290 Class A3 Flammable Refrigerant Used	
Model	R-290 Refrigerant Charge g (oz.)	Minimum Room Floor Area (operating or storage) Superficie Minimale du Local (service ou stockage) m ² (ft ²); m ² (pi ²)
KM-830MAK2	309 (10.9)	14.8 (159.1)
 <p>≥ Area m² (ft²) (see "Minimum Room Floor Area" above) ≥ Superficie m² (pi²) (voir « Superficie Minimale du Local » ci-dessus)</p>		
⚠ DANGER continued		
<p>R-290 Refrigerant Charge:</p> <ul style="list-style-type: none"> • If greater than 114 g (4 oz.), do not install in public corridor or lobby. • If greater than 152 g (5.3 oz.), do not install within 6 m (20 ft) of open flame. <p>Charge de réfrigérant R-290:</p> <ul style="list-style-type: none"> • Si elle est supérieure à 114 g (4 oz.), ne pas l'installer dans un couloir public ou un hall d'entrée. • Si elle est supérieure à 152 g (5.3 oz.), ne pas l'installer à moins de 6 m (20 pi) d'une flamme nue. 		
This appliance is intended for use at altitudes up to 7,000 m (22,965 ft).		

NOTICE

- The icemaker is not intended for outdoor use. Normal operating ambient temperature must be within 45°F to 100°F (7°C to 38°C); Normal operating water temperature must be within 45°F to 90°F (7°C to 32°C). Operation of the icemaker, for extended periods, outside of these normal temperature ranges may affect icemaker performance.
- The icemaker will not work at sub-freezing temperatures. To prevent damage to the water supply line, drain the icemaker if the air temperature is going to go below 32°F (0°C). See "V. Preparing the Appliance for Periods of Non-Use."
- Install the appliance in a location that is flat. The ice storage bin has adjustable legs, adjust to level as needed. Be sure the appliance is properly leveled to avoid improper operation, faulty system performance, and possible appliance damage.

- The appliance should not be located next to ovens, grills, or other high heat producing equipment.
- The location should provide a firm and level foundation for the appliance.
- Allow 6" (15 cm) clearance at rear, sides, and top for proper air circulation and ease of maintenance and/or service should they be required.

B. Checks Before Installation

- Visually inspect the exterior of the shipping container and immediately report any damage to the carrier. Upon opening the container, any concealed damage should also be immediately reported to the carrier.
- Remove the shipping carton, tape, and packing material. If any are left in the appliance, it will not work properly.
- See the nameplate on the rear panel, and check that your voltage supplied corresponds with the voltage specified on the nameplate.
- Remove the panels to prevent damage when installing the appliance. See "II.C. How to Remove Panels."
- Remove the package containing the accessories.
- Remove the protective plastic film from the panels. If the appliance is exposed to the sun or to heat, remove the film after the appliance cools.
- Check that the refrigerant lines do not rub or touch lines or other surfaces, and that the fan blade (if applicable) turns freely.
- Check that the compressor is snug on all mounting pads.
- The icemaker can be installed on a dispenser unit or ice storage bin. The ice storage bins listed below are recommended.

⚠ DANGER

This appliance shall be used on a dispenser unit/ice storage bin without electrical components or one designed to be used with flammable refrigerants, and of a size or type as indicated in this manual.

Model Number	Bin Width	Recommended Hoshizaki Ice Storage Bin
KM-830MAK2	30" or Wider	BD-500 Series

For further options, contact your local Hoshizaki distributor.

C. How to Remove Panels

See Fig. 1

- Front Panel: Remove the screw. Lift up and towards you.
- Top Panel: Lift up at front slightly, push rearward, then lift off.
- Right Side Panel: Remove the screw. Slide outward to the right slightly, then push rearward and remove.
- Top Insulation Panel: Pull forward slightly, then lift off.
- Front Insulation Panel: From the top, pull forward slightly, then lift off.

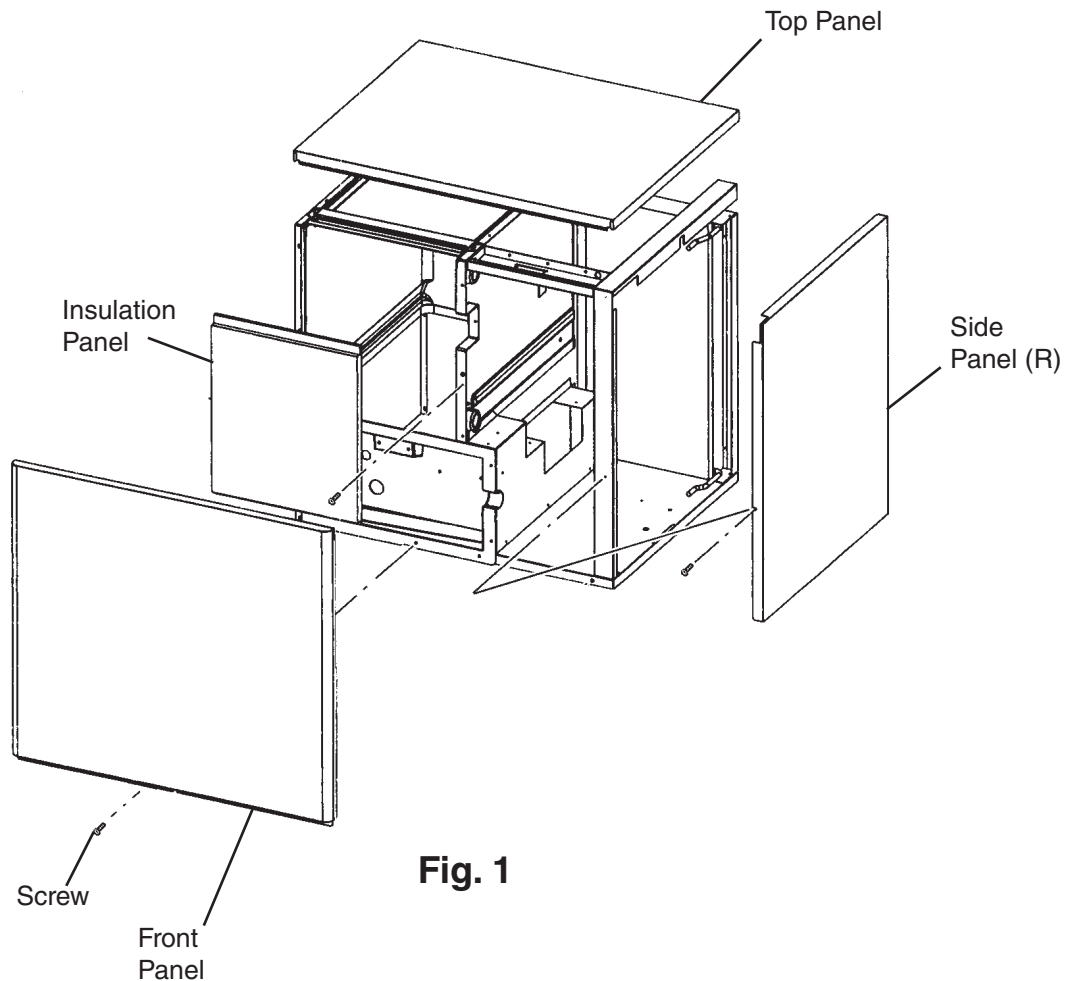

Fig. 1

D. Dispenser Unit/Ice Storage Bin and Icemaker Setup

⚠ DANGER

This appliance shall be used on a dispenser unit/ice storage bin without electrical components or one designed to be used with flammable refrigerants, and of a size or type as indicated in this manual.

⚠ WARNING

- The installer must ensure the dispenser unit/ice storage bin is compatible with the icemaker, and the dispenser unit/ice storage bin and icemaker are properly attached and secured.
- Do not allow top kits to interfere with the bin control lens sensing area or the icemaker will not operate properly.

- 1a) **Dispenser Unit:** Follow the dispenser unit's setup procedure.
- 1b) **Ice Storage Bin:** Unpack the ice storage bin and attach the 4 adjustable legs provided (bin accessory) to the bottom of the ice storage bin.
 - 2) Position the dispenser unit/ice storage bin in its permanent location.
 - 3) If required, install an adapter kit or top kit. Contact your local Hoshizaki distributor for recommendations.
 - 4) Level the dispenser unit/ice storage bin in both the left-to-right and front-to-rear directions. If using an ice storage bin, adjust the ice storage bin legs to level.
 - 5) Place the icemaker on top of the dispenser unit/ice storage bin.
- 6a) **Dispenser Unit:** Follow the dispenser unit, adapter kit, or top kit instructions for securing the icemaker. If no instructions are available, secure the icemaker using the mounting brackets provided. Rotate the mounting brackets so that they fit flush to the dispenser unit. See Fig. 2a. Secure the mounting brackets to the icemaker with the bolts provided. Secure the mounting brackets to the dispenser unit with self-tapping screws (not provided). **NOTICE! Use care to avoid damage to dispenser unit components when attaching the mounting brackets.**
- 6b) **Ice Storage Bin:** Follow the ice storage bin, adapter kit, or top kit instructions for securing the icemaker. If no instructions are available, secure the icemaker using the 2 mounting brackets and the bolts provided. See Fig. 2b.

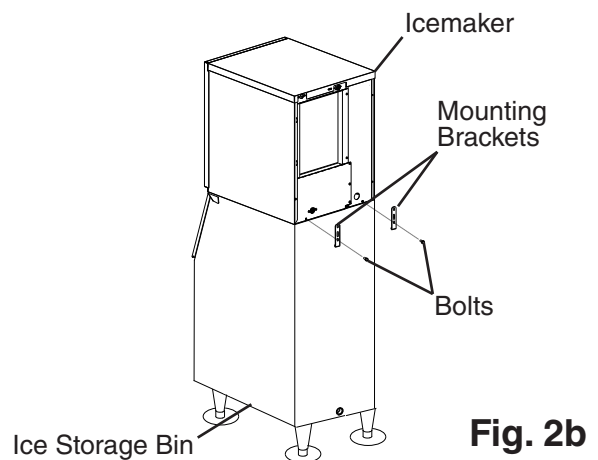
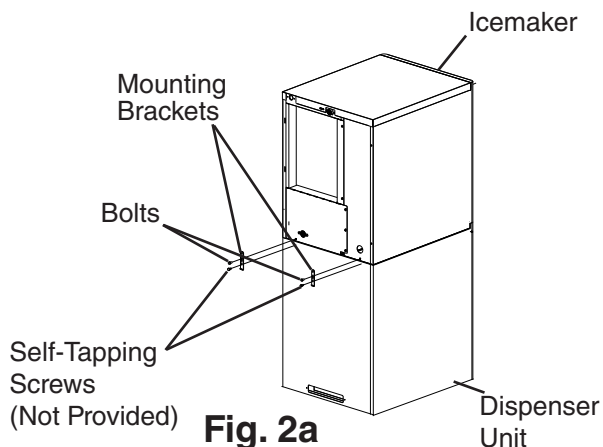

E. Electrical Connection

⚠ WARNING

For All Models

- Electrical connection must be hard-wired and must meet national, state, and local electrical code requirements. Failure to meet these code requirements could result in death, electric shock, serious injury, fire, or damage.
- The icemaker requires an independent power supply of proper capacity. See the nameplate for electrical specifications. Failure to use an independent power supply of proper capacity can result in a tripped breaker, blown fuse, damage to existing wiring, or component failure. This could lead to heat generation or fire.
- **THE APPLIANCE MUST BE GROUNDED.** Failure to properly ground the icemaker could result in death or serious injury.
- Electrical connection must be made in accordance with the instructions on the "WARNING" tag, provided with the pig tail leads in the junction box. See Fig. 3.
- To reduce the risk of electric shock, do not touch the control switch with damp hands.

- Usually an electrical permit and services of a licensed electrician are required.
- The maximum allowable voltage variation is ± 6 percent of the nameplate rating.
- The white lead must be connected to the neutral conductor of the power source.
NOTICE! Miswiring may result in severe damage to the icemaker.
- The opening for the power supply connection is 7/8" DIA. to fit a 1/2" trade size conduit.
- **NOTICE! Has the transformer's voltage tap switch been positioned to match incoming voltage at startup?**

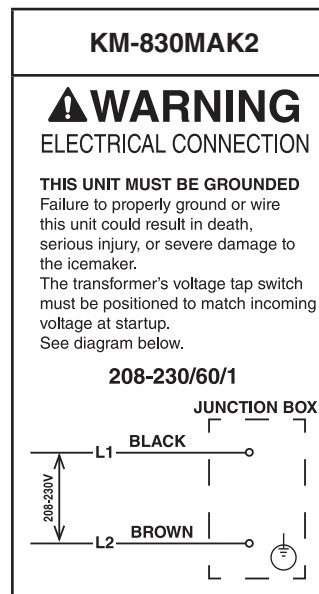

Fig. 3

F. Water Supply and Drain Connections

See Fig. 4

⚠ WARNING

- Water supply and drain connections must be installed in accordance with applicable national, state, and local regulations.
- Connect to potable water supply only. Do not connect to a hot-water supply.

NOTICE

- Normal operating water temperature must be within 45°F to 90°F (7°C to 32°C). Operation of the appliance, for extended periods, outside of this normal temperature range may affect appliance performance.
- Water supply pressure must be a minimum of 10 PSIG (68 kPaG) and a maximum of 113 PSIG (779 kPaG). If the pressure exceeds 113 PSIG (779 kPaG), the use of a pressure reducing valve is required.
- External filters, strainers, or softeners may be required depending on water quality. Contact your local Hoshizaki Certified Service Representative or local Hoshizaki distributor for recommendations.
- In areas where water damage is a concern, install in a contained area with a floor drain.
- Water line installation to the appliance is not warranted by Hoshizaki.
- Be sure there is sufficient extra water supply line and drain line for the appliance to be pulled out for service.
- Water-hammer issues must be resolved by a qualified plumber before installing the appliance. Water hammer can cause appliance damage that may lead to water leakage or flooding.
- A minimum of 3/4" nominal ID hard pipe or equivalent is required for the drain line. Installing a smaller diameter drain line will reduce water flow and may lead to water leakage or flooding.
- To prevent damage to the appliance, do not operate the appliance when the water supply is off, or if the pressure is below 10 PSIG (68 kPaG). Do not run the appliance until the proper water pressure is reached.

- A plumbing permit and services of a licensed plumber may be required in some areas.
- Water supply line size is critical to the operation of the appliance. Failure to provide adequate water supply to the appliance may result in damage to the appliance, damage to property, and may void the warranty.
- The icemaker drain line, dispenser unit/ice storage bin drain line, and water-cooled condenser drain line (if applicable) must be run separately.
- Drain lines must have 1/4" fall per foot (2 cm per 1 m) on horizontal runs to provide a proper drain flow. A vented tee connection is also required for proper flow.
- Drain lines should not be piped directly to the sewer system. An air gap of a minimum of 2 vertical inches (5 cm) should be between the end of the drain pipes from the icemaker, dispenser unit/ice storage bin, and water-cooled condenser (if applicable) and the floor drain.

1. Icemaker

Icemaker Water Supply Inlet	Minimum Icemaker Water Supply Line Size	Icemaker Drain Outlet	Minimum Icemaker Drain Line Size
1/2" Female Pipe Thread (FPT)	1/4" Nominal ID Copper Water Tubing or Equivalent	3/4" Female Pipe Thread (FPT)	3/4" Nominal ID Hard Pipe or Equivalent

- An icemaker water supply line shut-off valve and drain valve must be installed.
- Be sure there is sufficient extra water supply line and drain line for the appliance to be pulled out for service.

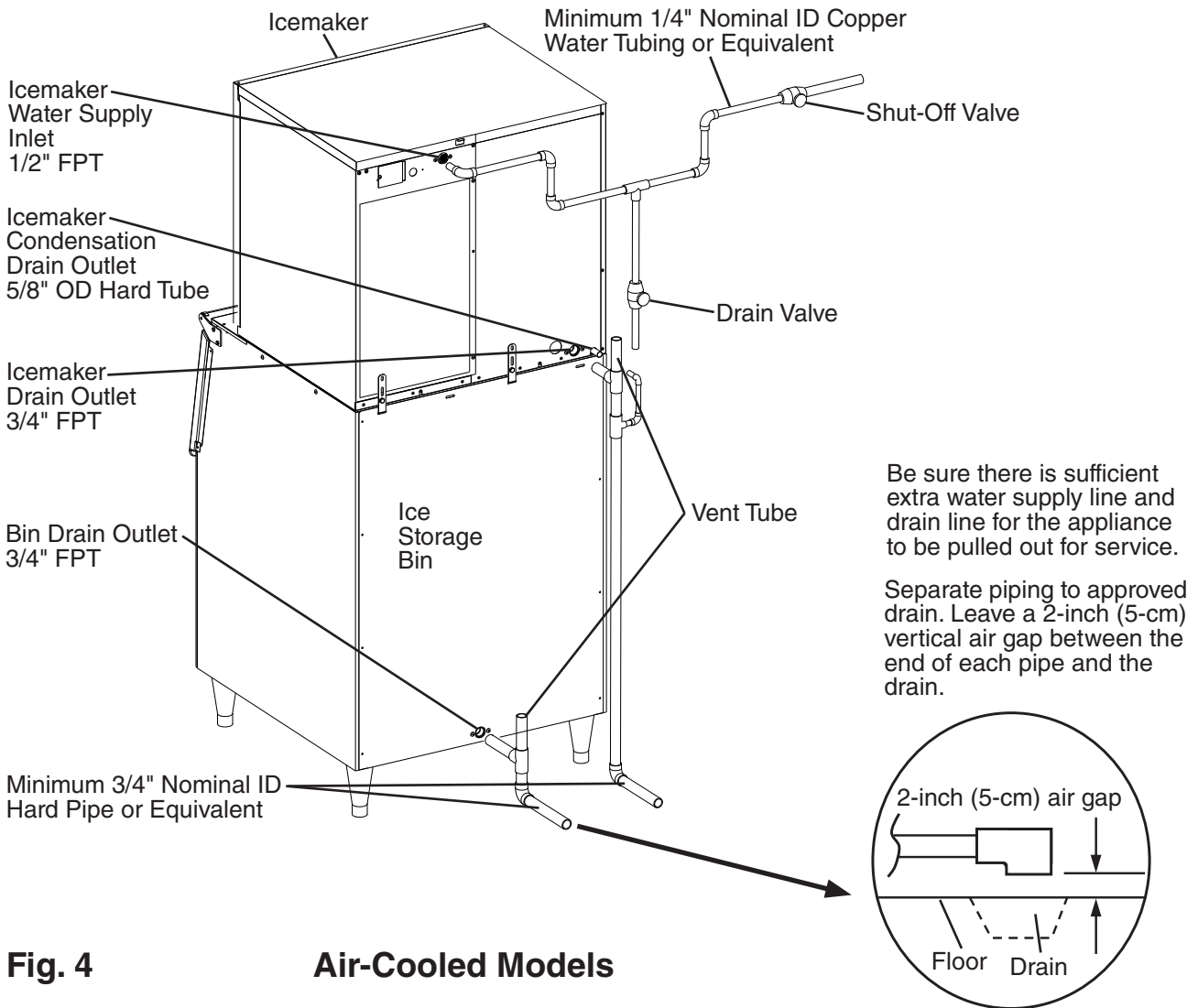

Fig. 4 Air-Cooled Models



G. Final Checklist

1. Pre-Startup

- 1) Is the appliance level?
- 2) Is the appliance in a site where the ambient temperature is within 45°F to 100°F (7°C to 38°C) and the water temperature within 45°F to 90°F (7°C to 32°C) all year around?
- 3) Is there at least 6" (15 cm) clearance at rear, sides, and top of the icemaker?
- 4) Have the shipping carton, tape, and packing material been removed from the appliance? Are the cube guides in the correct position?
- 5) Has the protective plastic film been removed from the panels?
- 6) Have all electrical and water connections been made? Do electrical and water connections meet applicable national, state, and local code and regulation requirements?
- 7) Has the power supply voltage been checked or tested against the nameplate rating? Has a proper ground been installed to the icemaker? **Has the main transformer's voltage tap switch been positioned to match incoming voltage?**
- 8) Are the water supply and drain lines sized as specified? Are the water supply line shut-off valve(s) and drain valve(s) installed? Has the water supply pressure been checked to ensure a minimum of 10 PSIG (68.9 kPaG) and a maximum of 113 PSIG (779.1 kPaG)?
- 9) Is the compressor snug on all mounting pads? Have the refrigerant lines been checked to make sure they do not rub or touch other lines or surfaces? Has the fan blade (if applicable) been checked to make sure it turns freely?
- 10) Continue to "III. Operating Instructions."

2. Post-Startup

⚠ WARNING
CHOKING HAZARD: Ensure all components, fasteners, and thumbscrews are securely in place after installation. Make sure that none have fallen into the dispenser unit/ice storage bin.

- 1) Has the bin control operation been confirmed?
- 2) Has the end user been given the instruction manual, and instructed on how to operate the appliance and the importance of the recommended periodic maintenance?
- 3) Are all components, fasteners, and thumbscrews securely in place?
- 4) Has the end user been given the contact information of an authorized service agent?
- 5) Has the warranty registration been completed and submitted to the factory?

III. Operating Instructions



R-290 Class A3 Flammable Refrigerant Used

⚠ DANGER

Risk of Fire or Explosion. Flammable Refrigerant Used.

- Be sure to follow all Important Safety Information located at the beginning of this manual.
- Failure to install, operate, and maintain the appliance in accordance with this manual will adversely affect safety, performance, component life, and warranty coverage and may result in costly water damage.
- Keep clear of obstruction all ventilation openings in the appliance enclosure or in the structure for building-in.

Risque D'Incendie ou D'Explosion. Fluide Frigorigène Inflammable Utilisé.

- Veuillez à respecter toutes les consignes de sécurité importantes figurant au début de ce manuel.
- Le fait de ne pas installer, utiliser et entretenir l'appareil conformément à ce manuel aura des conséquences négatives sur la sécurité, les performances, la durée de vie des composants et la couverture de la garantie, et peut entraîner des dégâts des eaux coûteux.
- Ne pas obstruer les ouvertures de ventilation dans l'enceinte de l'appareil ou dans la structure d'encastrement.

A. Important Notes About Usage

NOTICE

- Protect the floor when moving the appliance to prevent damage to the floor.
- Do not leave the appliance on during extended periods of non-use, extended absences, or in sub-freezing temperatures. To properly prepare the appliance for these occasions, follow the instructions in "V. Preparing the Appliance for Periods of Non-Use."
- Do not place objects on top of the appliance.
- The dispenser unit/ice storage bin is for ice use only. Do not store anything else in the dispenser unit/ice storage bin.
- If applicable, keep ventilation openings in the appliance clear of obstruction.

B. Startup

⚠ DANGER

This appliance shall be used on a dispenser unit/ice storage bin without electrical components or one designed to be used with flammable refrigerants, and of a size or type as indicated in this manual.

⚠ WARNING

- All parts are factory-adjusted. Improper adjustments may adversely affect safety, performance, component life, and warranty coverage.
- To reduce the risk of electric shock, do not touch the control switch or mode switch with damp hands.
- Improper adjustment may adversely affect safety, performance, component life, and warranty coverage.
- On dispenser unit applications, do not increase ice level above the recommended setting listed below. Higher ice levels could result in icemaker movement, water leakage, or ice overflow.
- Risk of electric shock. Control switch in "OFF" position does not de-energize all loads.

NOTICE

- If the appliance is turned off, wait for at least 3 minutes before restarting the appliance to prevent damage to the compressor.
- At startup, confirm that all internal and external connections are free of leaks.
- Do not allow top kits or top kit risers (if applicable) to interfere with the bin control lens sensing area or the icemaker will not operate properly.

- 1) Open the water supply line shut-off valve(s).
- 2) Remove the front panel.
- 3) Move the control switch on the control box to the "ON" position, then move the mode switch to the "ICE" position.
- 4) Replace the front panel in its correct position.
- 5) Turn on the power supply, and allow the appliance to operate for a total of 10 minutes.
- 6) Turn off the power supply, then remove the front panel.

7) Remove the insulation panel, then remove splash guard, cube guide B, and cube guide A. Next, remove the overflow cap, overflow pipe, water shield, and drain plug. See Fig. 5.

8) After the water tank has drained, replace all parts removed in step 7 in their correct positions. Be careful not to cross thread the drain plug or overflow pipe.

9) Clean the dispenser unit/ice storage bin liner using a neutral cleaner. Rinse thoroughly after cleaning.

10) Replace the front panel in its correct position.

11) Turn on the power supply to start the automatic icemaking process.

12) During the first 5 minutes of the freeze cycle, confirm bin control operation by pressing and holding the bin control's actuator paddle until the appliance shuts down. The appliance should shut down in approximately 15 seconds.

13) Return to "II.G.2 Post-Startup" and complete final checklist.

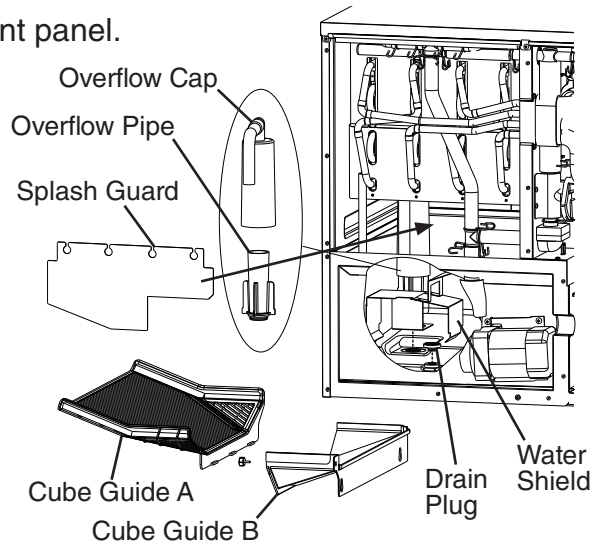

Fig. 5

C. Alarm Safeties

Should an alarm occur, follow the instructions in the table below to address the alarm. If an alarm continues to occur, contact an authorized service agent. In case of alarm, the built-in safeties shut down the appliance and an audible alarm sounds as listed below.

Type	Alarm	Notes and Reset Options
1 Beep	High Evaporator Temp. (temperature > 127°F) (53°C)	Check for harvest problem (stuck HGV or relay), hot water entering unit, stuck HM, or shorted thermistor.
2 Beep	Harvest Backup Timer (harvest > 20 min. for two cycles in a row)	Check thermistor (open), HGV not opening, TXV or LLV leaking by, low charge, inefficient Comp, or WRV leaking by.
3 Beep	Freeze Timer (freeze > freeze timer setting for two cycles in a row)	Check FS stuck closed (up), WV leaking by, HGV leaking by, PM not pumping, TXV defective, LLV not opening, low charge, HM not bypassing, or inefficient Comp.
To reset above safeties, press "ALARM RESET" button with power supply on.		
6	Low Voltage (92Vac±5% or less)	Red "POWER" LED turns off if voltage protection operates.
7	High Voltage (147Vac±5% or more)	Control voltage safeties automatically reset when voltage is corrected.
"Power" LED Blink Only	Freeze Up Detection Cycle	Freeze up detection cycle initiated. "POWER" LED blinks until 6 FS activated freeze cycles completed or control board manually reset. See service manual for details.

Legend: **Comp**—compressor; **CV**—cleaning valve; **DV**—drain valve; **FM**—fan motor; **FS**—float switch; **HGV**—hot gas valve; **LLV**—liquid line valve; **PM**—pump motor; **TXV**—thermostatic expansion valve; **WRV**—water regulating valve; **WV**—inlet water valve

IV. Maintenance

The appliance must be maintained in accordance with the instruction manual and labels provided. Consult with your local Hoshizaki Certified Service Representative about maintenance service.

WARNING

- Items listed under "IV.A. User Maintenance Schedule" may be performed by the user; otherwise, only qualified service technicians should service the appliance.
- Failure to install, operate, and maintain the equipment in accordance with this manual will adversely affect safety, performance, component life, and warranty coverage.
- To reduce the risk of electric shock, do not touch the control switch or mode switch with damp hands.
- **Before Performing Maintenance/Service:** Move the control switch to the "OFF" position and turn off the power supply. Lockout/Tagout to prevent the power supply from being turned back on inadvertently. Control switch in "OFF" position does not de-energize all loads.
- **CHOKING HAZARD:** Ensure all components, fasteners, and thumbscrews are securely in place after any maintenance is done to the appliance. Make sure that none have fallen into the dispenser unit/ice storage bin.
- After service, make sure that there are no wires pinched between the panels and appliance. Make sure you do not damage or pinch the water supply line or drain line.

A. User Maintenance Schedule

The user maintenance schedule below is a guideline. More frequent maintenance may be required depending on water quality, the appliance's environment, and local sanitation regulations.

Maintenance Schedule		
Frequency	Area	Task
Daily	Scoop	Clean the ice scoop using a neutral cleaner. Rinse thoroughly after cleaning.
Bi-Weekly	Air Filters	Inspect. Wash with warm water and neutral cleaner if dirty.
Monthly	Appliance Exterior	Wipe down with a clean, soft cloth. Use a damp cloth containing a neutral cleaner to wipe off oil or dirt build up. Clean any chlorine staining (rust colored spots) using a non-abrasive cleanser.

B. Service Maintenance Schedule

The service maintenance schedule below is a guideline; service maintenance items are to be performed by qualified service technicians only. More frequent maintenance may be required depending on water quality, the appliance's environment, and local sanitation regulations.

Maintenance Schedule		
Frequency	Area	Task
Monthly	External Water Filters	Check for proper pressure and change if necessary.
	Bin Control Lens	Wipe down the bin control lens (located on the bottom of the icemaker) with a neutral cleaner. Rinse thoroughly after cleaning.
	Underside of Icemaker and Top Kits; Bin Door and Snout	Wipe down with a clean, soft cloth. Use a damp cloth containing a neutral cleaner to wipe off oil or dirt build up. Clean any chlorine staining (rust colored spots) using a non-abrasive cleanser.
Yearly	Icemaker and Dispenser Unit/Ice Storage Bin	Clean and sanitize per the cleaning and sanitizing instructions provided in this manual.
	Water Supply Inlet	Close the icemaker water supply line shut-off valve and drain the water system. Clean the water supply inlet screen.
	Condenser	Inspect. Clean if necessary by using a brush or vacuum cleaner. More frequent cleaning may be required depending on location.
	Water Hoses	Inspect the water hoses and clean/replace if necessary.

C. Cleaning and Sanitizing Instructions

The icemaker must be cleaned and sanitized at least once a year. More frequent cleaning and sanitizing may be required in some water conditions.

⚠ WARNING

- To prevent injury to individuals and damage to the icemaker, do not use ammonia type cleaners.
- Carefully follow any instructions provided with the bottles of cleaning and sanitizing solution.
- Always wear liquid-proof gloves and goggles to prevent the cleaning and sanitizing solutions from coming into contact with skin or eyes.
- Do not leave the icemaker unattended when panels are off.

IMPORTANT

- To prevent damage to the water pump, do not leave the control switch in the "PUMP" position for extended periods when the water tank is empty.
- Terminating a cleaning/sanitizing cycle early:
 - a) Terminating a cleaning cycle at step 4 or earlier in "Cleaning" below, returns the icemaker to the normal icemaking mode. The control board "CLEAN" LED turns off.
 - b) Terminating a cleaning cycle at step 5 or later in "Cleaning" below, sends the icemaker into a 3-rinse cycle (approx. 18 min.). The control board "CLEAN" LED remains on throughout the 3-rinse cycles. After the 3rd rinse cycle, icemaker goes into the normal icemaking mode and the control board "CLEAN" LED turns off.

Preparation

- 1) Remove the front panel, then move the control switch to the "OFF" position. Make sure the mode switch is in the "ICE" position. After 3 minutes, move the control switch to the "ON" position and replace the front panel.
- 2) Allow the appliance to run until the compressor energizes. Once the compressor energizes, allow the appliance to run for an additional 3 minutes, then remove the front panel and control box cover. Move the control switch to the "OFF" position.
- 3) Remove all ice from the dispenser unit/ice storage bin. **WARNING! If on a dispenser unit, turn off the dispenser unit power supply after dispensing the ice.**

Cleaning

- 4) Move the mode switch to the "CLEAN" position, then move the control switch to the "ON" position (1 short beep occurs, then 3 seconds later 1 long beep occurs). Replace the front panel. The water tank drains and then fills.
- 5) When the control board starts beeping (2 beep sequence), remove the front panel. Move the control switch to the "OFF" position.
- 6) Remove the front insulation panel, then pour 14 fl. oz. (414 ml) of Hoshizaki "Scale Away" into the water tank. Replace the front insulation panel.
- 7) Move the control switch to the "ON" position (1 short beep occurs, then 3 seconds later 1 long beep occurs). Replace the front panel. To avoid excessive foaming in the water tank, there is a 1 minute delay before circulation begins. After approximately 30 minutes of circulation, the icemaker performs 3 rinse cycles.
- 8) When the control board starts beeping (5 beep sequence), remove the front panel. Move the control switch to the "OFF" position.
- 9) In bad or severe water conditions, turn off the power supply, then remove, clean (cleaning solution = 5 oz. Hoshizaki "Scale Away" per gallon of warm water), rinse, and replace the cube guide, float switch, water supply tubes, spray tubes, and spray guides; turn on the power supply when complete. Otherwise, continue to step 10.

Sanitizing

- 10) Confirm the mode switch is in the "CLEAN" position, then move the control switch to the "ON" position (1 short beep occurs, then 3 seconds later 1 long beep occurs). Replace the front panel. The water tank drains and then fills.
- 11) When the control board starts beeping (2 beep sequence), remove the front panel. Move the control switch to the "OFF" position.
- 12) Remove the front insulation panel, then pour 0.85 fl. oz. (25 ml) of a 7.5% sodium hypochlorite solution (chlorine bleach) into the water tank. Replace the front insulation panel. **IMPORTANT! Use regular bleach with no additives. Using a bleach with additives causes excessive foaming during sanitizing, reducing the effectiveness of sanitizing.**
- 13) Move the control switch to the "ON" position (1 short beep occurs, then 3 seconds later 1 long beep occurs). Replace the front panel. To avoid excessive foaming in the water tank, there is a 1 minute delay before circulation begins. After approximately 30 minutes of circulation, the icemaker performs 3 rinse cycles.
- 14) When the control board starts beeping (5 beep sequence), remove the front panel. Move the control switch to the "OFF" position.
- 15) Clean the dispenser unit/ice storage bin liner using a neutral cleaner. Rinse thoroughly after cleaning.
- 16) Move the mode switch to the "ICE" position, then move the control switch to the "ON" position. Note: If on a dispenser unit, turn on the dispenser unit power supply.
- 17) Replace all panels and covers in their correct positions.

V. Preparing the Appliance for Periods of Non-Use

NOTICE
<ul style="list-style-type: none">• When storing the icemaker for an extended time or in sub-freezing temperatures, follow the instructions below to prevent damage.• To prevent damage to the water pump seal, do not leave the control switch in the "PUMP" position for extended periods when the water tank is empty.

When the icemaker is not used for two or three days under normal conditions, it is sufficient to move the control switch to the "OFF" position. When storing the icemaker for an extended time or in sub-freezing temperatures, follow the instructions below.

1. Remove the water from the icemaker water supply line:

- 1) Turn off the power supply, then remove the front panel.
- 2) Move the control switch to the "OFF" position.
- 3) Close the icemaker water supply line shut-off valve, then open the icemaker water supply line drain valve.
- 4) Allow the line to drain by gravity.
- 5) Attach a compressed air or carbon dioxide supply to the icemaker water supply line drain valve.
- 6) Move the control switch to the "ON" position, then confirm the mode switch is in the "ICE" position.
- 7) Replace the front panel in its correct position, then turn on the power supply.
- 8) Blow the icemaker water supply line out using the compressed air or carbon dioxide supply.
- 9) Close the icemaker water supply line drain valve.

2. Drain the water tank:

- 1) Turn off the power supply, then remove the front panel.
- 2) Move the control switch to the "OFF" position.
- 3) Remove the insulation panel. Remove splash guard, cube guide B, then remove cube guide A. Remove the overflow cap, overflow pipe, and water shield. See Fig. 6.

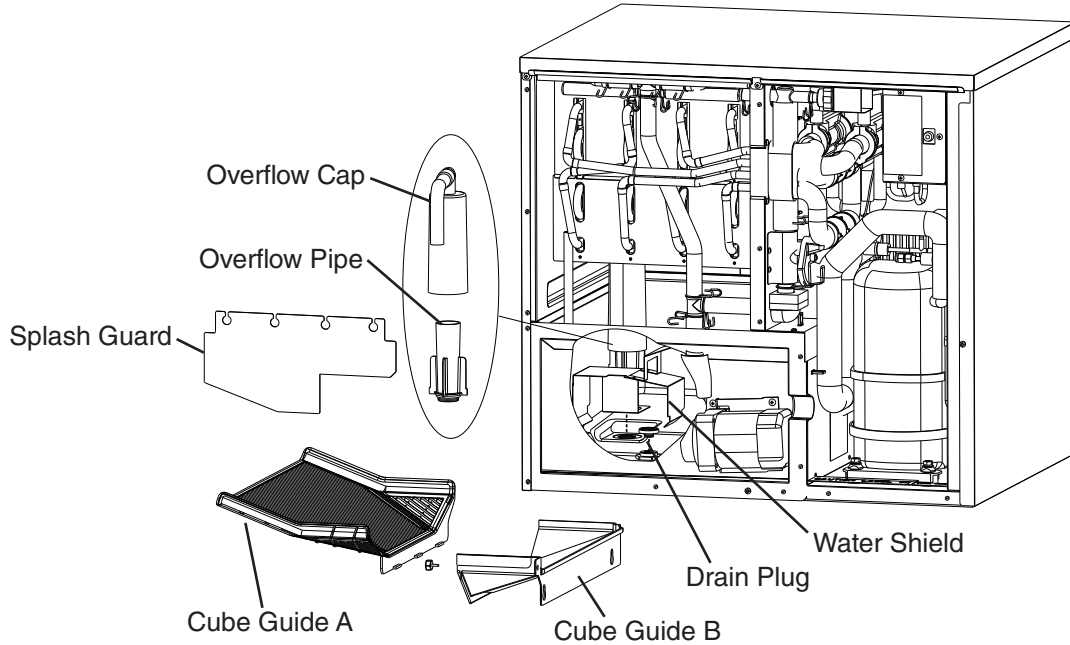

Fig. 6

- 4) Remove the drain plug.
- 5) Remove all ice from the dispenser unit/ice storage bin. Clean the dispenser unit/ice storage bin using a neutral cleaner. Rinse thoroughly after cleaning.
- 6) Replace the drain plug, water shield, overflow pipe, overflow cap, cube guide A, cube guide B, splash guard, and insulation panel in their correct positions. Be careful not to cross thread the drain plug or overflow pipe.
- 7) Replace the front panel in its correct position.

VI. Decommissioning and Disposal



R-290 Class A3 Flammable Refrigerant Used

⚠ DANGER

Risk of Fire or Explosion. Flammable Refrigerant Used.

- Only qualified service technicians should install and service the appliance.
- Follow handling instructions carefully in compliance with national regulations.
- Dispose of properly in accordance with federal or local regulations.
- Do not puncture refrigerant tubing. Risk of fire or explosion due to puncture of refrigerant tubing; follow handling instructions carefully.
- Be sure to follow the full Decommissioning and Disposal information located in the Service Manual for this model. The Service Manual is available at www.hoshizakiamerica.com.

Risque D'Incendie ou D'Explosion. Fluide Frigorigène Inflammable Utilisé.

- Seuls des techniciens de service qualifiés doivent installer et entretenir l'appareil.
- Suivre attentivement les instructions de manutention conformément aux règlements nationaux.
- Mettre au rebut conformément aux conformément aux règlements fédéraux ou locaux.
- Ne pas perforer la conduite de fluide frigorigène. Risque d'incendie ou d'explosion en cas de perforation d'une canalisation de fluide frigorigène; suivez attentivement les instructions de manutention.
- Veiller à respecter l'ensemble des informations relatives à la mise hors service et à la mise au rebut figurant dans le manuel d'entretien de ce modèle. Le manuel d'entretien est disponible à l'adresse suivante: www.hoshizakiamerica.com.

HOSHIZAKI AMERICA, INC.

618 Hwy. 74 South, Peachtree City, GA 30269 USA (P) 770.487.2331 (F) 770.487.3360 hoshizakiamerica.com 1A8478-010

