

**SEARS**

OWNERS  
MANUAL

MODEL NO.  
315.174921

CAUTION:  
Read Rules for  
Safe Operation  
and Instructions  
Carefully

SAVE THIS  
MANUAL FOR  
FUTURE REFERENCE

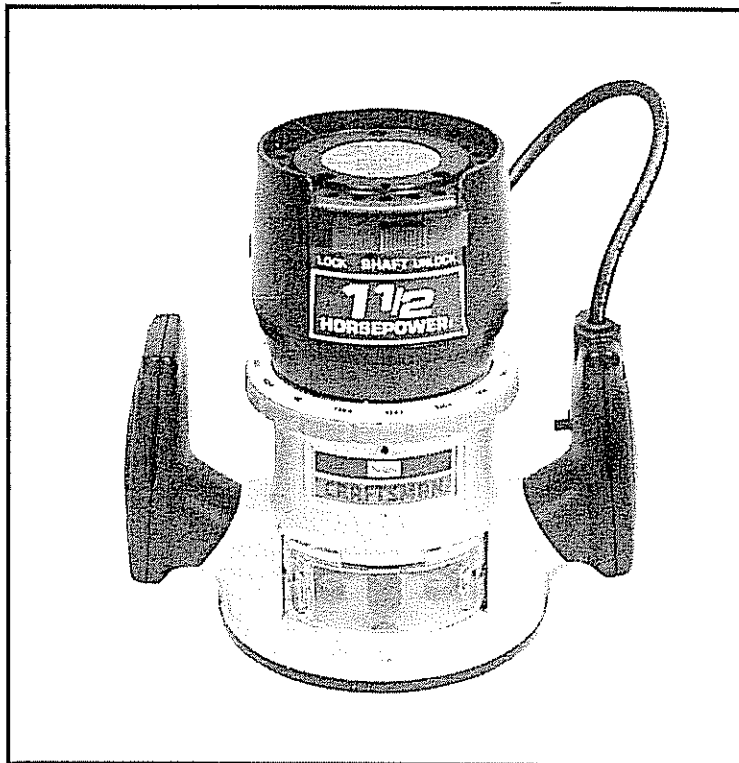

**CRAFTSMAN<sup>®</sup>**

**ROUTER  
DOUBLE INSULATED**

Introduction  
Operation  
Maintenance  
Repair Parts



Designed exclusively for and sold only by  
SEARS, ROEBUCK AND CO., Dept. 698/731A, Sears Tower, Chicago, IL 60684

812547-559  
10-88

PRINTED IN U.S.A.

### FULL ONE YEAR WARRANTY ON CRAFTSMAN ROUTER

If this Craftsman Router fails to give complete satisfaction within one year from the date of purchase, **RETURN IT TO THE NEAREST SEARS STORE THROUGHOUT THE UNITED STATES** and Sears will repair it, free of charge.

If this router is used for commercial or rental purposes this warranty applies for only 90 days from the date of purchase.

This warranty gives you specific legal rights, and you may also have other rights which vary from state to state.

SEARS, ROEBUCK AND CO.  
DEPT. 698/731A  
SEARS TOWER  
CHICAGO, IL 60684

## INTRODUCTION

**DOUBLE INSULATION** is a concept in safety, in electric power tools, which eliminates the need for the usual three wire grounded power cord and grounded supply system. Wherever there is electric current in the tool there are two complete sets of insulation to protect the user. All exposed metal parts are isolated from the internal metal motor components with protecting insulation.

**IMPORTANT** — Servicing of a tool with double insulation requires extreme care and knowledge of the system and should be performed only by a qualified service technician. For service we suggest you return the tool to your nearest Sears Store for repair. Always use original factory replacement parts when servicing.

### GENERAL

Your router is a versatile woodworking tool which will give you years of trouble-free performance. It is engineered with the professional in mind, but its ease of operation allows the amateur to produce work which is beautiful and precise.

### RULES FOR SAFE OPERATION

**WARNING — DO NOT ATTEMPT TO OPERATE UNTIL YOU HAVE READ THOROUGHLY AND UNDERSTAND COMPLETELY ALL INSTRUCTIONS, SAFETY RULES, ETC. CONTAINED IN THIS MANUAL. FAILURE TO COMPLY CAN RESULT IN ACCIDENTS INVOLVING FIRE, ELECTRIC SHOCK, OR SERIOUS PERSONAL INJURY. SAVE OWNERS MANUAL AND REVIEW FREQUENTLY FOR CONTINUING SAFE OPERATION, AND INSTRUCTING POSSIBLE THIRD-PARTY USER.**

### READ ALL INSTRUCTIONS

1. **KNOW YOUR POWER TOOL** — Read owner's manual carefully. Learn its applications and limitations as well as the specific potential hazards related to this tool.
2. **GUARD AGAINST ELECTRICAL SHOCK BY PREVENTING BODY CONTACT WITH GROUNDED SURFACES.** For example: Pipes, radiators, ranges, refrigerator enclosures.
3. **KEEP GUARDS IN PLACE** and in working order.
4. **KEEP WORK AREA CLEAN.** Cluttered areas and benches invite accidents.
5. **AVOID DANGEROUS ENVIRONMENT.** Don't use power tool in damp or wet locations or expose to rain. Keep work area well lit.
6. **KEEP CHILDREN AWAY.** All visitors should wear safety glasses and be kept a safe distance from work area. Do not let visitors contact tool or extension cord.
7. **STORE IDLE TOOLS.** When not in use, tool should be stored in a dry, high or locked-up place — out of the reach of children.
8. **DON'T FORCE TOOL.** It will do the job better and safer at the rate for which it was designed.
9. **USE RIGHT TOOL.** Don't force small tool or attachment to do the job of a heavy duty tool. Don't use tool for purpose not intended — for example — Don't use a circular saw for cutting tree limbs or logs.

## RULES FOR SAFE OPERATION (Continued)

10. **WEAR PROPER APPAREL.** No loose clothing or jewelry to get caught in moving parts. Rubber gloves and footwear are recommended when working outdoors. Also, wear protective hair covering to contain long hair.
11. **USE SAFETY GLASSES** with all tools. Also face or dust mask if cutting operation is dusty.
12. **DON'T ABUSE CORD.** Never carry tool by cord or yank it to disconnect from receptacle. Keep cord from heat, oil and sharp edges.
13. **SECURE WORK.** Use clamps or a vise to hold work. It's safer than using your hand and it frees both hands to operate tool.
14. **DON'T OVERREACH.** Keep proper footing and balance at all times. Do not use on a ladder or unstable support.
15. **MAINTAIN TOOLS WITH CARE.** Keep tools sharp at all times, and clean for best and safest performance. Follow instructions for lubricating and changing accessories.
16. **DISCONNECT TOOLS.** When not in use, before servicing, or when changing attachments, blades, bits, cutters, etc., all tools should be disconnected from power supply.
17. **REMOVE ADJUSTING KEYS AND WRENCHES.** Form habit of checking to see that keys and adjusting wrenches are removed from tool before turning it on.
18. **AVOID ACCIDENTAL STARTING.** Don't carry plugged-in tools with finger on switch. Be sure switch is off when plugging in.
19. **OUTDOOR USE EXTENSION CORDS.** When tool is used outdoors, use only extension cords suitable for use outdoors. Outdoor approved cords are marked with the suffix W-A, for example — SJTW-A or SJOW-A.
20. **KEEP CUTTERS CLEAN AND SHARP.** Sharp cutters minimize stalling and kickback.
21. **KEEP HANDS AWAY FROM CUTTING AREA.** Keep hands away from cutters. Do not reach underneath work while cutter is rotating. Do not attempt to remove material while cutter is rotating.
22. **NEVER USE IN AN EXPLOSIVE ATMOSPHERE.** Normal sparking of the motor could ignite fumes.
23. **INSPECT TOOL CORDS PERIODICALLY** and if damaged, have repaired at your nearest Sears Repair Center. Stay constantly aware of cord location.
24. **INSPECT EXTENSION CORDS PERIODICALLY** and replace if damaged.
25. **KEEP HANDLES DRY, CLEAN, AND FREE FROM OIL AND GREASE.** Always use a clean cloth when cleaning. Never use brake fluid, gasoline, or any strong solvents to clean your tool.
26. **STAY ALERT.** Watch what you are doing and use common sense. Do not operate tool when you are tired. Do not rush.
27. **CHECK DAMAGED PARTS.** Before further use of the tool, a guard or other part that is damaged should be carefully checked to determine that it will operate properly and perform its intended function. Check for alignment of moving parts, binding of moving parts, breakage of parts, mounting, and any other conditions that may affect its operation. A guard or other part that is damaged should be properly repaired or replaced by an authorized service center unless indicated elsewhere in this instruction manual.
28. **DO NOT USE TOOL IF SWITCH DOES NOT TURN IT ON AND OFF.** Have defective switches replaced by authorized service center.
29. Inspect for and remove all nails from lumber before routing.
30. **DRUGS, ALCOHOL, MEDICATION.** Do not operate tool while under the influence of drugs, alcohol, or any medication.
31. **WEAR HEARING PROTECTION DURING EXTENDED PERIODS OF OPERATION.**
32. **SAVE THESE INSTRUCTIONS.** Refer to them frequently and use them to instruct third-party users. If you loan someone this tool, loan them these instructions also.

# OPERATION

**WARNING: YOUR ROUTER SHOULD NEVER BE CONNECTED TO POWER SUPPLY WHEN YOU ARE ASSEMBLING PARTS OR MAKING ADJUSTMENTS. FAILURE TO UNPLUG YOUR ROUTER COULD RESULT IN ACCIDENTAL STARTING RESULTING IN POSSIBLE SERIOUS INJURY. ALWAYS WEAR SAFETY GOGGLES OR SAFETY GLASSES WITH SIDE SHIELDS BEFORE BEGINNING POWER TOOL OPERATION.**

If any parts are missing do not operate your Router until the missing parts are replaced See Figure 1.

Make sure power supply is 110-120 volts, 60 Hz, AC only.

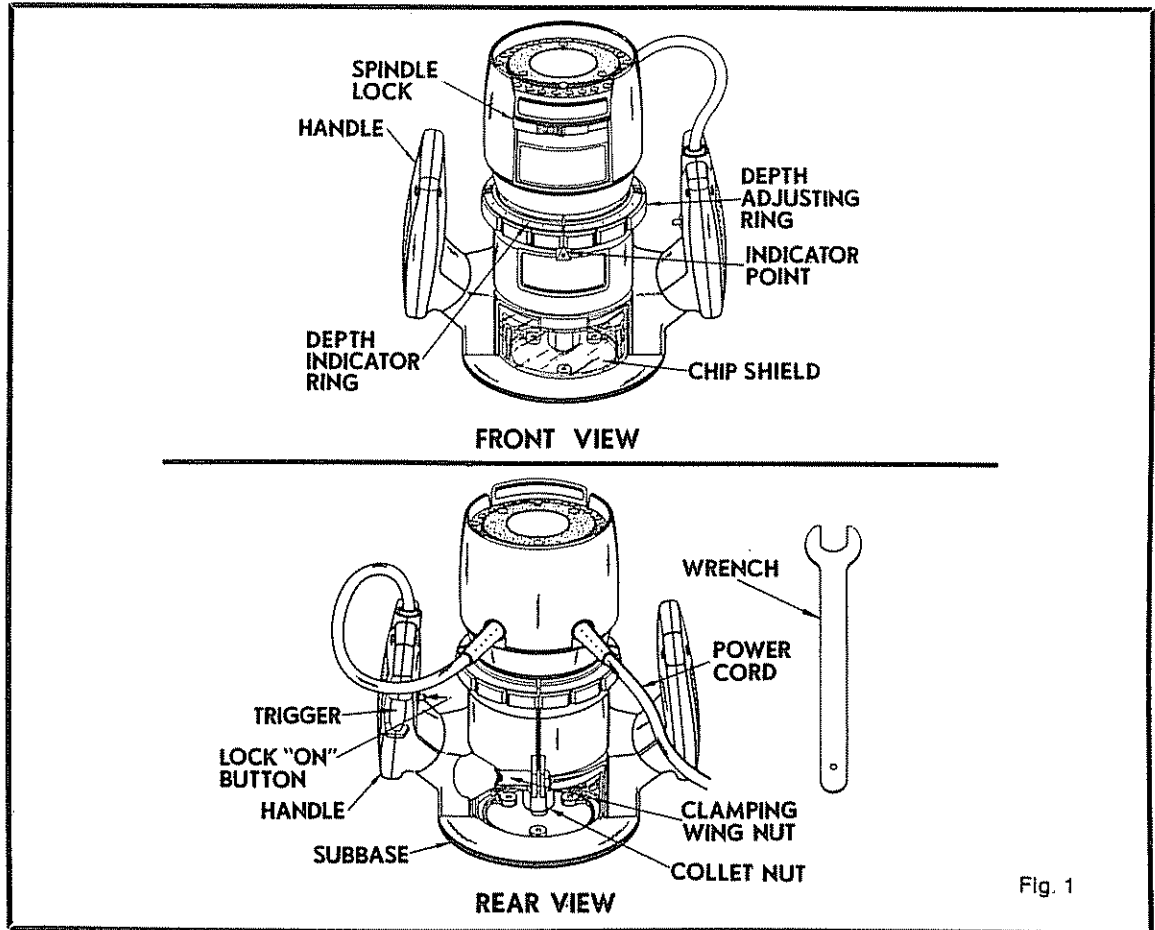

Fig. 1

## CAUTION:



The operation of any Router can result in foreign objects being thrown into your eyes, which can result in severe eye damage. Before commencing power tool operation, always wear safety goggles or safety glasses with side shields and a full face shield when needed. We recommend wide vision safety mask for use over spectacles or standard safety glasses with side shields, available at Sears Catalog Order or Retail Stores.

# OPERATION

## KNOW YOUR ROUTER

Before attempting to use your router, familiarize yourself with all operating features and safety requirements. See Figure 1.

**⚠ WARNING: DO NOT ALLOW FAMILIARITY WITH YOUR ROUTER TO MAKE YOU CARELESS. REMEMBER THAT A CARELESS FRACTION OF A SECOND IS SUFFICIENT TO INFLICT SEVERE INJURY.**

## CHIP SHIELD

A clear plastic chip shield is installed on the front of your router for protection against flying dust and chips. The chip shield is designed to fit the front opening of the router base as shown in figure 1. If necessary to remove, squeeze the tabs on each end and pull outward. To replace, squeeze the tabs at each end, fit into the opening, then release. **FOR YOUR PROTECTION DO NOT USE ROUTER WITHOUT CHIP SHIELD PROPERLY IN PLACE.**

## SWITCH

The switch of your router is equipped with a "lock-on" feature which is convenient when operating for extended periods of time. To lock on, depress the trigger, push in the lock button located on the side of the handle, then while holding the lock button pushed in, release the trigger. To release the lock, depress the trigger and release it.

**⚠ WARNING: BEFORE CONNECTING YOUR ROUTER TO POWER SUPPLY SOURCE, ALWAYS CHECK TO BE SURE SWITCH IS NOT IN "LOCK-ON" POSITION. FAILURE TO DO SO COULD RESULT IN ACCIDENTAL STARTING OF YOUR ROUTER RESULTING IN POSSIBLE SERIOUS INJURY.**

## INSTALLING/REMOVING CUTTERS

See Figures 2 & 3

### 1. UNPLUG YOUR ROUTER.

**⚠ WARNING: FAILURE TO UNPLUG YOUR ROUTER COULD RESULT IN ACCIDENTAL STARTING CAUSING SERIOUS INJURY.**

2. A spindle lock is located on the front of the motor housing. See Figure 1. To activate lock, push spindle lock in and slide into lock position. **NEVER ATTEMPT TO ACTIVATE SPINDLE LOCK WHILE ROUTER MOTOR IS RUNNING OR COASTING TO A STOP.**
3. Place your router upside down on table, then turn collet nut with wrench until lock mechanism interlocks. See Figure 2. **NOTE:** Spindle lock is spring loaded and will snap into position when lock mechanism interlocks.

**⚠ WARNING: IF YOU ARE CHANGING A CUTTER IMMEDIATELY AFTER USE, BE CAREFUL NOT TO TOUCH THE CUTTER OR COLLET WITH YOUR HANDS OR FINGERS. THEY WILL GET BURNED BECAUSE OF THE HEAT BUILDUP FROM CUTTING. ALWAYS USE THE WRENCH PROVIDED.**

4. Remove cutters by turning collet nut counterclockwise enough to allow cutter to slip easily from collet. See Figure 3. The collet is machined to precision tolerances to fit cutters with 1/4" diameter shank size.
5. With your router still upside down on table, insert shank of cutter into collet. The shank of your cutter should be close to but not touching bottom of collet.
6. Tighten the collet nut securely by turning clockwise with the wrench provided. See Figure 3. Put spindle lock back in unlock position. Otherwise the interlocking mechanism of the spindle lock will not let your router turn on.

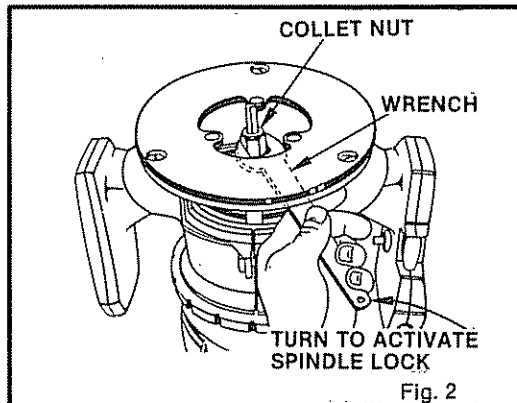

Fig. 2

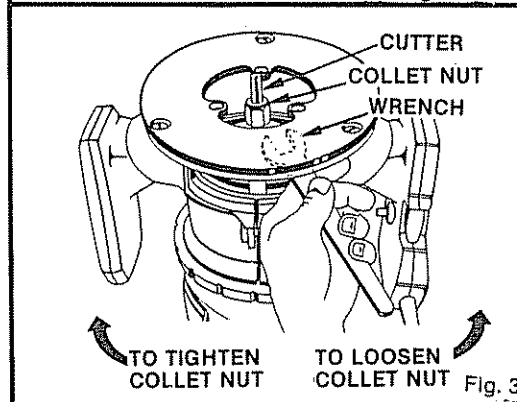

Fig. 3

**⚠ WARNING: DO NOT USE CUTTERS WITH UNDERSIZED SHANKS. UNDERSIZED SHANKS WILL NOT TIGHTEN PROPERLY AND COULD BE THROWN FROM TOOL CAUSING INJURY.**

# OPERATION

## DEPTH OF CUT ADJUSTMENTS

We recommend that cuts be made at a depth not exceeding 1/8" and that several passes be made to reach depths of cut greater than 1/8".

### 1. UNPLUG YOUR ROUTER.

**WARNING: FAILURE TO UNPLUG YOUR ROUTER COULD RESULT IN ACCIDENTAL STARTING CAUSING SERIOUS INJURY.**

2. Place your router on a flat surface, loosen clamping wing nut, and adjust until cutter is inside sub-base. See Figure 4.
3. Turn the depth adjusting ring until tip of cutter touches flat surface. Turn the depth indicator ring until the zero lines up with the indicator point on the base. See Figure 4.
4. Position your router so that the bit can extend below the subbase for desired depth setting.
5. Turn the depth adjusting ring to obtain the desired depth of cut. The distance the cutter moves can be read on the depth indicator ring. Each notch on the depth adjusting ring indicates 1/64 inch change in depth setting.
6. Tighten clamping wing nut securely before operating router.

**WARNING: BE ABSOLUTELY CERTAIN CLAMPING WING NUT IS FIRMLY TIGHTENED. FAILURE TO DO THIS WILL RESULT IN THE MOTOR MOVING INSIDE THE BASE CAUSING AN UNEVEN CUT. THIS COULD CAUSE LOSS OF CONTROL RESULTING IN POSSIBLE SERIOUS INJURY.**

**WARNING: ALWAYS WEAR SAFETY GOGGLES OR SAFETY GLASSES WITH SIDE SHIELDS WHEN USING YOUR ROUTER. FAILURE TO DO SO COULD RESULT IN DUST OR CHIPS BEING THROWN IN YOUR EYES RESULTING IN POSSIBLE SERIOUS INJURY. IF THE CUTTING OPERATION IS DUSTY, ALSO WEAR A FACE OR DUST MASK.**

## ROUTING

See Figure 5.

For ease of operation and maintaining proper control your router has two handles, one on each side of the router base. When using your router hold it firmly with both hands as shown in figure 5. Turn router on and let motor build to its full speed, then gradually feed cutter into workpiece. Remain alert and watch what you are doing. **DO NOT** operate router when fatigued.

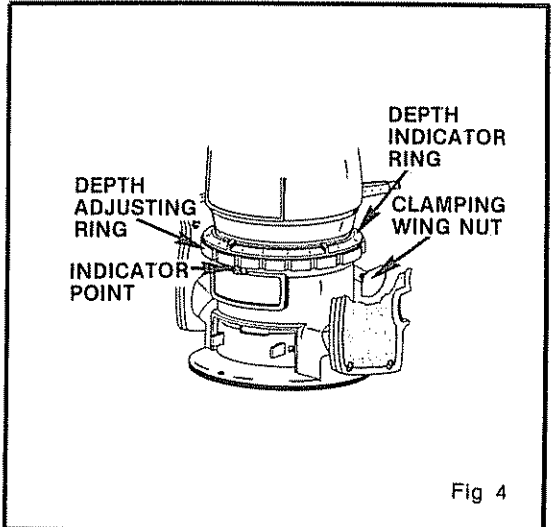
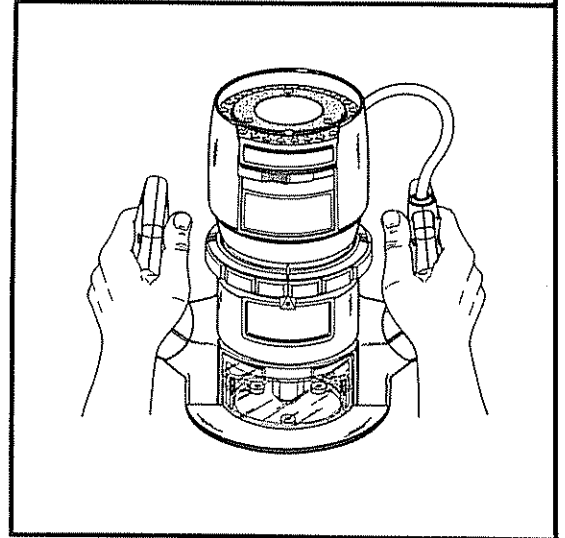

Fig 4



# OPERATION

## RATE-OF-FEED

**IMPORTANT:** The whole "secret" of professional routing and edge shaping lies in making a careful set-up for the cut to be made and in selecting the proper rate of feed.

## FORCE FEEDING

Clean, smooth routing and edge shaping can be done only when the bit is revolving at a relatively high speed and is taking very small bites to produce tiny, cleanly severed chips. If your router is forced to move forward too fast, the RPM of the bit becomes slower than normal in relation to its forward movement. As a result, the bit must take bigger bites as it revolves. "Bigger bites" mean bigger chips, and a rougher finish. Bigger chips also require more power, which could result in the router motor becoming overloaded.

Under extreme forcefeeding conditions the relative RPM of the bit can become so slow — and the bites it has to take so large — that chips will be partially knocked off (rather than fully cut off), with resulting splintering and gouging of the workpiece. See *Figure 6*.

Your Craftsman Router is an extremely high-speed tool (25,000 rpm no-load speed), and will make clean, smooth cuts if allowed to run freely without the overload of a forced (too fast) feed. Three things that cause "force feeding" are bit size, depth-of-cut, and workpiece characteristics. The larger the bit or the deeper the cut, the more slowly the router can be moved forward. If the wood is very hard, knotty, gummy or damp, the operation must be slowed still more.

You can always detect "force feeding" by the sound of the motor. Its high-pitched whine will sound lower and stronger as it loses speed. Also, the strain of holding the tool will be noticeably increased.

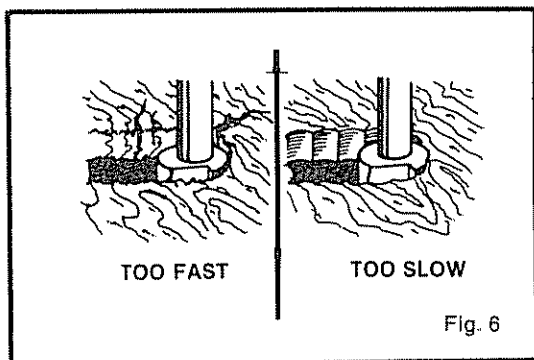

## TOO SLOW FEEDING

It is also possible to spoil a cut by moving the router forward too slowly. When it is advanced into the work too slowly a revolving bit does not dig into new wood fast enough to take a bite; instead, it simply scrapes away sawdust-like particles. Scraping produces heat, which can glaze, burn, or mar the cut — in extreme cases, can even overheat the bit so as to destroy its hardness.

In addition, it is more difficult to control a router when the bit is scraping instead of cutting. With practically no load on the motor the bit will be revolving at close to top rpm, and will have a much greater than normal tendency to bounce off the sides of the cut (especially, if the wood has a pronounced grain with hard and soft areas). As a result, the cut produced may have rippled, instead of straight sides. See *Figure 6*.

"Too-slow feeding" can also cause your router to take off in a wrong direction from the intended line of cut. **Always grasp and hold your router firmly with both hands when routing.**

You can detect "too-slow feeding" by the runaway, too-highly pitched sound of the motor; or by feeling the "wobble" of the bit in the cut.

## PROPER FEEDING

The right feed is neither too fast nor too slow. It is the rate at which the bit is being advanced firmly and surely to produce a continuous spiral of uniform chips — without hogging into the wood to make large individual chips or, on the other hand, to create only sawdust. If you are making a small diameter, shallow groove in soft, dry wood, the proper feed may be about as fast as you can travel your router along your guide line. On the other hand, if the bit is a large one, the cut is deep or the wood is hard to cut, the proper feed may be a very slow one. Then, again, a cross-grain cut may require a slower pace than an identical with grain cut in the same workpiece.

There is no fixed rule. You will learn by experience... by listening to the router motor and by feeling the progress of each cut. If at all possible, always test a cut on a scrap piece of the workpiece wood beforehand.

# OPERATION

## DEPTH OF CUT

As previously mentioned, the depth of cut is important because it affects the rate of feed which, in turn, affects the quality of a cut (and, also, the possibility of damage to your router motor and bit). A deep cut requires a slower feed than a shallow one; and a too-deep cut will cause you to slow the feed so much that the bit is no longer cutting, it is scraping, instead.

Making a deep cut is never advisable. The smaller bits — especially those only 1/16 inch in diameter — are easily broken off when subjected to too much side thrust. A large enough bit may not be broken off, but if the cut is too deep a rough cut will result — and it may be very difficult to guide and control the bit as desired. For these reasons, we recommend that you do not exceed 1/8 inch depth of cut in a single pass, regardless of the bit size or the softness or condition of the workpiece. See Figure 7.

To make deeper cuts it is therefore necessary to make as many successive passes as required, lowering the bit 1/8 inch for each new pass. In order to save time, do all the cutting necessary at one depth setting, before lowering the bit for the next pass. This will also assure a uniform depth when the final pass is completed. See Figure 8.

## DIRECTION OF FEED AND THRUST

The router motor and bit revolve in a clockwise direction. This gives the tool a slight tendency to twist (in your hands) in a counterclockwise direction, especially when the motor revs up (as at starting).

Because of the extremely high speed of bit rotation during a "proper feeding" operation, there is very little kickback to contend with under normal conditions. However, should the bit strike a knot, hard grain, foreign object, etc. that would affect the normal progress of the cutting action, there will be a slight kickback — sufficient to spoil the trueness of your cut if you are not prepared. Such a kickback is always in the direction opposite to the direction of bit rotation.

To guard against such a kickback, plan your set-up and direction of feed so that you will always be thrusting the tool — to hold it against whatever you are using to guide the cut — in the same direction that the leading edge of the bit is moving. In short, the thrust should be in a direction that keeps the sharp edges of the bit continuously biting straight into new (uncut) wood.

## ROUTING

Whenever you are routing a groove, your travel should be in a direction that places whatever guide you are using at the right-hand side. In short, when

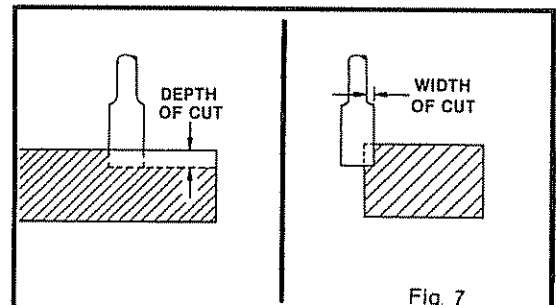

Fig. 7

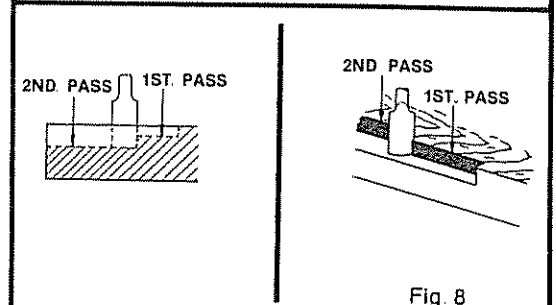

Fig. 8

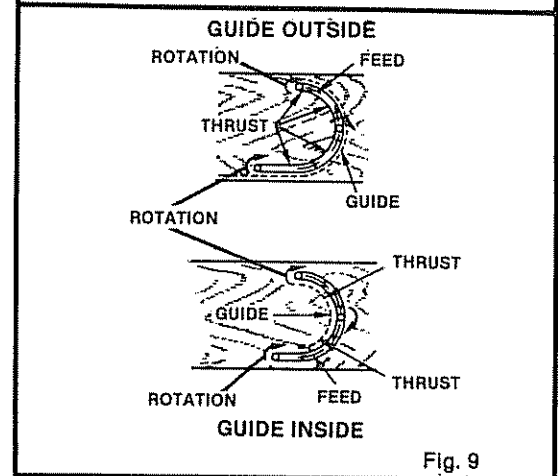

Fig. 9

the guide is positioned as shown in the first part of Figure 9, tool travel should be left to right and counterclockwise around curves. When the guide is positioned as shown in the second part of Figure 9 tool travel should be right to left and clockwise around curves. If there is a choice, the first set-up is generally the easiest to use. In either case, the sideways thrust you use is against the guide.

# OPERATION

## STARTING AND ENDING A CUT

### INTERNAL ROUTING

Tilt router and place on workpiece, letting edge of subbase contact workpiece first. Be careful not to let router bit contact workpiece. Turn router on and let motor build to its full speed. Gradually feed cutter into workpiece until subbase is level with workpiece.

**⚠WARNING: KEEP A FIRM GRIP ON ROUTER WITH BOTH HANDS AT ALL TIMES. FAILURE TO DO SO COULD RESULT IN LOSS OF CONTROL LEADING TO POSSIBLE SERIOUS INJURY.**

Upon completion of cut, turn motor off and let it come to a complete stop before removing router from work surface.

**⚠WARNING: NEVER PULL ROUTER OUT OF WORK AND PLACE UPSIDE DOWN ON WORK SURFACE BEFORE THE CUTTER STOPS ROTATING.**

### EDGE ROUTING

Place router on workpiece, making sure the router bit does not contact workpiece. Turn router on and let motor build to its full speed. Begin your cut, gradually feeding cutter into workpiece.

**⚠WARNING: KEEP A FIRM GRIP ON ROUTER WITH BOTH HANDS AT ALL TIMES. FAILURE TO DO SO COULD RESULT IN LOSS OF CONTROL LEADING TO POSSIBLE SERIOUS INJURY.**

Upon completion of cut, turn motor off and let it come to a complete stop before removing router from work surface.

**⚠WARNING: NEVER PULL ROUTER OUT OF WORK AND PLACE UPSIDE DOWN ON WORK SURFACE BEFORE THE CUTTER STOPS ROTATING.**

## EDGING WITH THE PILOT BITS

The arbor-type bits with pilots are excellent for quick easy, edge shaping of any workpiece edge that is either straight or curved at a curvature as great or greater than the radius of the bit to be used. The pilot prevents the bit from making too deep a cut; and holding the pilot firmly in contact with the workpiece edge throughout prevents the cut from becoming too shallow.

Whenever the workpiece thickness together with the desired depth of cut (as adjusted by router depth setting) are such that only the top part of the edge is to be shaped (leaving at least a 1/16 in. thick uncut portion at bottom), the pilot can ride against the uncut portion, which will serve to guide it. See Figure 10. However, if the workpiece is too thin or the bit set too low so that there will be no uncut edge to ride the pilot against, an extra board to act as a guide must be placed under the workpiece. This "guide" board must have exactly the same contour — straight or curved — as the workpiece edge. If it is positioned so that its edge is flush with the workpiece edge, the bit will make a full cut (in as far as the bit radius). On the other hand, if the guide is positioned as shown in Figure 10 (out from the workpiece edge), the bit will make less than a full cut — which will alter the shape of the finished edge.

**NOTE:** Any of the piloted bits can be used without a pilot for edge shaping with guides, as preceding. The size (diameter) of the pilot that is used determines the maximum cut width that can be made with the pilot against the workpiece edge (the small pilot exposes all of the bit; the large one reduces this amount by 1/16 inch).

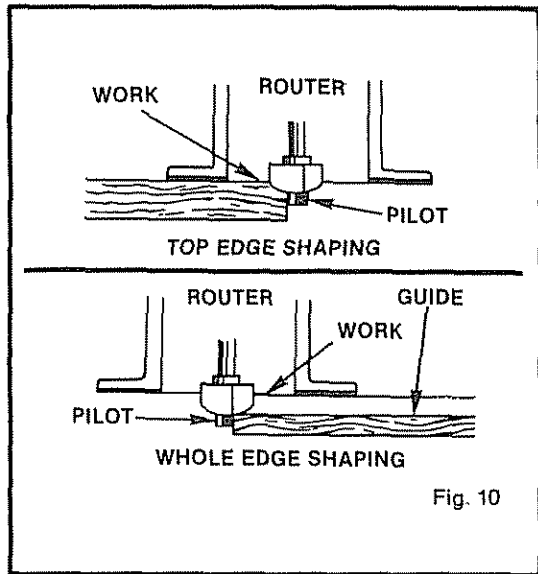

Fig. 10



# OPERATION

## ROUTING WITH GUIDE BUSHINGS

When using the Template Guide Bushings Cat. No. 9-25082 with your router you must visually center the bit with the bushing before beginning your cut. Your router subbase may be adjusted by loosening the screws holding the subbase to your router. Be sure clamping wing nut is securely tightened before centering bit in bushing. After centering bit with bushing tighten screws firmly.

**WARNING: FAILURE TO CENTER BIT WITH BUSHING OR TO FIRMLY TIGHTEN SCREWS AFTER CENTERING COULD CAUSE BIT TO COME IN CONTACT WITH BUSHING RESULTING IN SERIOUS INJURY.**

## EXTENSION CORDS

The use of any extension cord will cause some loss of power. To keep the loss to a minimum and prevent tool overheating, follow the recommended cord sizes on the chart at right. When tool is used outdoors, use only extension cords suitable for outdoor use and so marked. Extension cords are available at Sears Catalog Order or Retail Stores.













Extension Cord Length	Wire Size A.W.G.
25-50 Feet	18
50-75 Feet	16
75-100 Feet	14

**WARNING: CHECK EXTENSION CORDS BEFORE EACH USE. IF DAMAGED, REPLACE IMMEDIATELY. NEVER USE TOOL WITH A DAMAGED CORD SINCE TOUCHING THE DAMAGED AREA COULD CAUSE ELECTRICAL SHOCK RESULTING IN SERIOUS INJURY.**

THE FOLLOWING RECOMMENDED ACCESSORIES WERE AVAILABLE AT THE TIME THIS MANUAL WAS PRINTED.

Dovetail Template (9 2579)  
 Box Joint Template (9 2580)  
 Butt Hinge Template (9 2575)  
 Butt Hinge Template (9 2564C)  
 Router-Crafter (9 2525C)  
 Multi-Purpose Router Guide (9 25179)

Template Guide Bushings (9 25082)  
 Rout-A-Form Pantograph (9 25183C)  
 Template Set (9 2573)  
 Sharpening Kit (9 66501)  
 Carrying Case (9 14701)  
 Full View Router Base (9 25086)

COMBI-NATION PANEL CUTTER	VENING BITS	CORE BOX BIT	STRAIGHT FACE BITS	COMBI-NATION STRAIGHT, BEVEL CUTTER	HINGE MORTISING BIT	DOVETAIL CUTTER BITS	RABBET BIT	OGEE	COVE BIT	BEAD QUARTER-ROUND BITS	ARBOR
											
2554-1/4" *25541-1/4"	25500-1/16" 2550-1/8" 25502-3/16" 25503-7/32" 25594-3/4"  DOUBLE END 25545 45°, 60° V-GROOVE	25596-1/2"  V-GROOVE CHAMFER  2557-1/2" *25578-1/2"	2552-1/8" 25521-1/4" 25522-3/8" 25523-1/2" 25529-3/4"  *25524-1/4" *25525-5/16" *25526-3/8" *25527-1/2"	FOR FORMICA *2541  VENEER CUTTER  STRAIGHT *2541J  BEVEL *25412	1/2" 2555	2553-1/4" 25531-1/2"	1/4, 5/16, 3/8"  25581 *25582	3/16" 25585  ROMAN O	25572-3/8" 25571-1/2"  *25576-3/8" *25575-1/2"  45° CHAMFER BIT  25589	25563-1/4" 25562-3/8" 25561-1/2"  *25566-3/8" *25565-1/2"	2589      WITH 2 BALL BEARINGS (1/2 & 5/8")  25895
*CARBIDE TIPPED BITS											

**CAUTION:** The use of attachments or accessories not listed above might be hazardous.



# MAINTENANCE

## WHEN SERVICING USE ONLY IDENTICAL REPLACEMENT PARTS

### PROPER CARE OF CUTTERS

Get faster more accurate cutting results by keeping cutters clean and sharp. Remove all accumulated pitch and gum from cutters after each use.

A cutter sharpening kit (cat. no. 66501) is available from Sears Catalog Order or Retail Stores.

When sharpening cutters, sharpen only the inside of the cutting edge. Never grind the outside diameter. Be sure when sharpening the end of a cutter to grind the clearance angle the same as originally ground.

### PROPER CARE OF COLLET

From time to time, it also becomes necessary to clean your collet and collet nut. To do so, simply remove collet nut from collet and clean the dust and chips that have collected. Then return collet nut to its original position.

### SWITCH REPLACEMENT

#### 1. UNPLUG YOUR ROUTER.

**WARNING: FAILURE TO UNPLUG YOUR ROUTER COULD RESULT IN ACCIDENTAL STARTING CAUSING SERIOUS INJURY.**

SWITCH REPLACEMENT IS AS FOLLOWS:

2. Remove screws (A) and handle cover (C). See Figure 11.
3. NOTE THE LOCATIONS OF GROMMET (D) AND ALL WIRING IN THE HANDLE. ALSO NOTE HOW EACH LEAD IS CONNECTED TO THE SWITCH. Connections and wiring position must be identical when installing new switch. See Figure 11.
4. Remove leads from switch by inserting a 1/32" diameter nail or pin into switch lead receptacle as shown in figure 12 and pulling on the lead. Remove nail or pin with a twisting, pulling motion.
5. Make sure grommet (D) is on cord, then make lead connections to the new switch. Push each lead as far as possible into proper receptacle in switch. Pull on leads to check lead connections with lead receptacles.
6. Locate switch in handle and place leads so they won't be pinched or contact screws when handle cover is replaced.
7. Make sure grommet (D) is in place and replace handle cover and screws.
8. Tighten all screws securely.

### LIGHT BULB REPLACEMENT

#### 1. UNPLUG YOUR ROUTER.

**WARNING: FAILURE TO UNPLUG YOUR ROUTER COULD RESULT IN ACCIDENTAL STARTING CAUSING SERIOUS INJURY.**

2. Remove cutter from router. Adjust router to maximum height.
3. Remove screws (A) and subbase (B). See Figure 13.

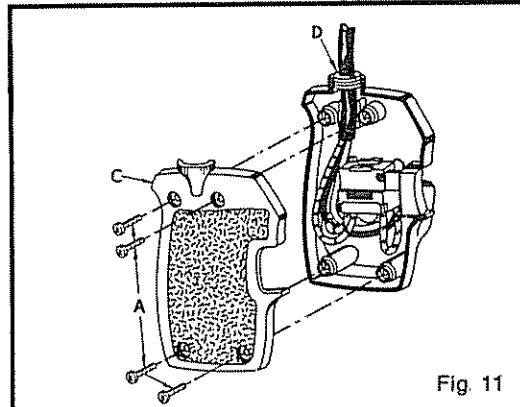

Fig. 11

1/32" DIAMETER NAIL OR PIN

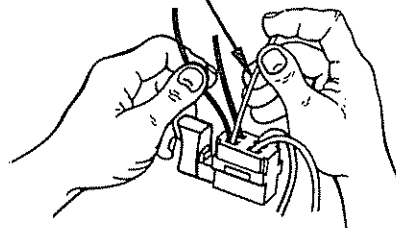

Fig. 12

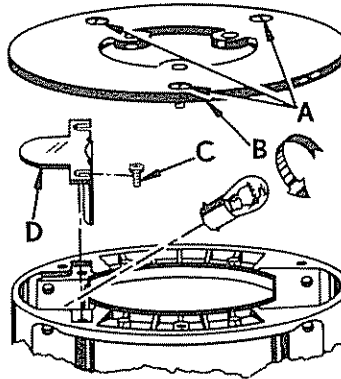

Fig. 13

4. Remove screw (C) and work light lens (D).
5. With bulb pointing toward you, push bulb in and turn to the left to remove.
6. Reassemble all parts and tighten all screws securely.

# MAINTENANCE (Cont'd.)

## WHEN SERVICING USE ONLY IDENTICAL REPLACEMENT PARTS

### GENERAL

Only the parts shown on parts list, page fifteen, are intended to be repaired or replaced by the customer. All other parts represent an important part of the double insulated system and should be serviced only by a qualified Sears service technician.

Avoid using solvents when cleaning plastic parts. Most plastics are susceptible to various types of commercial solvents and may be damaged by their use. Use clean cloths to remove dirt, carbon dust, etc.

**WARNING: DO NOT AT ANY TIME LET BRAKE FLUIDS, GASOLINE, PETROLEUM-BASED PRODUCTS, PENETRATING OILS, ETC. COME IN CONTACT WITH PLASTIC PARTS. THEY CONTAIN CHEMICALS THAT CAN DAMAGE, WEAKEN, OR DESTROY PLASTIC.**

When electric tools are used on fiberglass boats, sports cars, etc. it has been found that they are subject to accelerated wear and possible premature failure, as the fiberglass chips and grindings are highly abrasive to bearings, brushes, commutators, etc. Consequently it is not recommended that this tool be used for extended work on any fiberglass material. During any use on fiberglass it is extremely important that the tool is cleaned frequently by blowing with an air jet. **ALWAYS WEAR SAFETY GOGGLES, SAFETY GLASSES WITH SIDE SHIELDS, OR A DUST MASK BEFORE BEGINNING POWER TOOL OPERATION OR BLOWING DUST.**

## HELPFUL HINTS

- Always clamp workpiece securely before routing.
- A safe operator is one who thinks ahead.
- Always wear eye protection when routing.
- Make set-up adjustments carefully. Then double check. Measure twice and cut once.
- Keep cutters clean and properly sharpened.
- Don't let familiarity make you careless.
- Study all safety rules and do the job safely.
- **NEVER** place your hands in jeopardy.
- Make certain clamps can't loosen while in use.
- Test difficult set-ups on scrap — Don't waste lumber.
- Plan each operation before you begin.
- **THINK SAFETY BY THINKING AHEAD.**



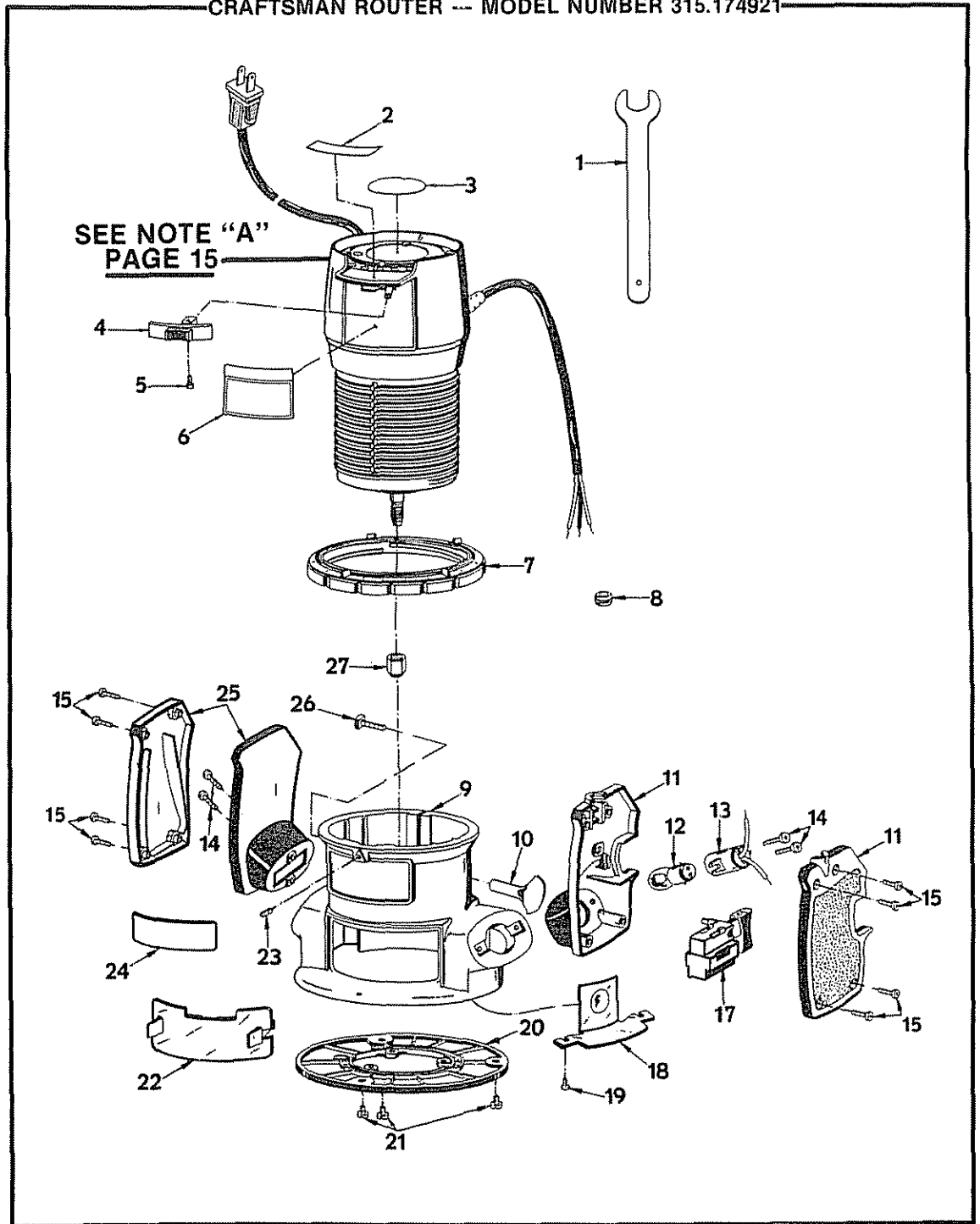

**CRAFTSMAN ROUTER — MODEL NUMBER 315.174921**

The Model Number will be found on a plate attached to the End Cap. Always mention the Model Number in all correspondence regarding your ROUTER or when ordering repair parts.

**SEE BACK PAGE FOR PARTS ORDERING INSTRUCTIONS**

**PARTS LIST**

Key No.	Part Number	Description	Quantity
1	989935-003	Wrench	1
2	989610-001	Caution Label	1
3	967543-001	Data Plate	1
4	612839-001	Actuator	1
5	612866-001	Cap Screw (#5-40 x 1/4 Soc Hd)	1
6	989392-001	H P. Logo	1
7	989652-001	Depth Adjust Ring and Indicator Assembly	1
8	623782-001	Grommet	1
9	612442-435	Base	1
10	623815-002	Clamping Wing Nut	1
11	611457-000	Power Handle Assembly	1
12	610951-001	Light Bulb (Standard Automotive Bulb #1004)	1
13	610930-001	Light Housing	1
14	606066-002	*Screw (#10-32 x 11/16 Pan Hd)	4
15	616081-013	*Screw (#8-18 x 1/2 Pan Hd. T.C.)* *STD610805	8
17	623814-004	Switch	1
18	610946-001	Work Light Lens	1
19	989684-001	*Screw (#6-32 x 1/4 T F)	1
20	612191-004	Subbase	1
21	998586-001	*Screw (#10-32 x 1/4 Pan Hd)	3
22	606688-001	Chip Shield	1
23	726676-002	Set Screw (#8-32 x 7/16 Hex Socket, Self Locking)	1
24	610956-001	Logo Plate	1
25	611456-000	Handle Assembly	1
26	623166-002	Sq Hd. Bolt	1
27	989985-003	Collet Nut	1
	612547-559	Owner's Manual	

NOTE "A" — The assembly shown represents an important part of the Double Insulated System. To avoid the possibility of alteration or damage to the System, service should be performed by your nearest Sears Repair Center. Contact your nearest Sears Catalog Order or Retail Store

\*Standard Hardware Item — May Be Purchased Locally  
 \*\*Available From Div. 98 — Source 980 00



**SEARS**

OWNERS  
MANUAL

SERVICE

MODEL NO.  
315.174921

HOW TO ORDER  
REPAIR PARTS

**CRAFTSMAN**

ROUTER  
DOUBLE INSULATED

Now that you have purchased your Router, should a need ever exist for repair parts or service, simply contact any Sears Service Center and most Sears, Roebuck and Co. stores. Be sure to provide all pertinent facts when you call or visit.

The model number of your Router will be found on the plate attached to the end cap.

WHEN ORDERING REPAIR PARTS, ALWAYS GIVE THE FOLLOWING INFORMATION:

- |                              |                          |
|------------------------------|--------------------------|
| • PART NUMBER                | • PART DESCRIPTION       |
| • MODEL NUMBER<br>315.174921 | • NAME OF ITEM<br>Router |

All parts listed may be ordered from any Sears Service Center and most Sears stores.

If the parts you need are not stocked locally, your order will be electronically transmitted to a Sears Repair Parts Distribution Center for handling.