

# CRAFTSMAN®

**5 Horsepower  
22 Inch Dual Stage  
120V. Electric Start  
SNOWTHROWER**

**MODEL NO.  
536.884790**

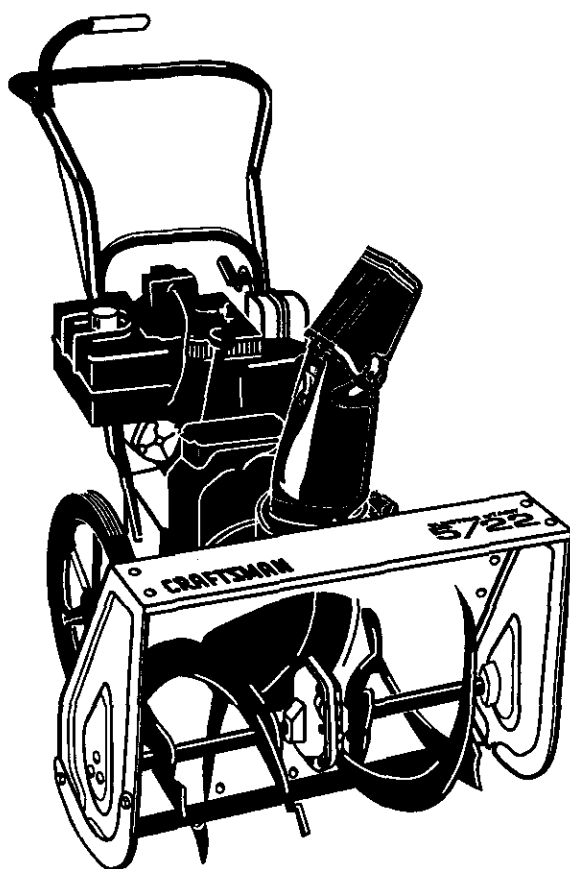

**Caution:  
Read and follow all Safety  
Rules and Operating  
Instructions before first use  
of this product.**

**SEARS, ROEBUCK AND CO., Hoffman Estates, IL 60179 U.S.A.**

760985 09/16/97

SAFETY

ASSEMBLY

OPERATION

MAINTENANCE

PARTS LIST

ESPAÑOL

## TABLE OF CONTENTS

Table of Contents	2	Service and Adjustments	14-17
Warranty	2	Storage	18
Safety Rules	2-4	Troubleshooting	19
Contents of Shipping Carton	4-5	Repair Parts	20-26
Assembly	5-7	Engine Repair Parts	27-31
Operation	8-12	Spanish(Español)	32-51
Maintenance	12-14	Parts Ordering/Service	Back Cover

## WARRANTY STATEMENT

### LIMITED TWO-YEAR WARRANTY ON CRAFTSMAN SNOW THROWER

For two years from the date of purchase, when this Craftsman Snow Thrower is maintained, lubricated, and tuned up according to the operating and maintenance instructions in the owner's manual, Craftsman will repair, free of charge, any defect in material or workmanship.

If this Craftsman Snow Thrower is used for commercial or rental purposes, this warranty applies for only 90 days from the date of purchase.

This warranty does not cover the following:

- Items which become worn during normal use, such as spark plugs, drive belts and shear pins.
- Repairs necessary because of operator abuse or negligence, including bent crank shafts and the failure to maintain the equipment according to the instructions contained in the owner's manual.

WARRANTY SERVICE IS AVAILABLE BY RETURNING THE CRAFTSMAN SNOW THROWER TO THE NEAREST CRAFTSMAN SERVICE CENTER/DEPARTMENT IN THE UNITED STATES. THIS WARRANTY APPLIES ONLY WHILE THIS PRODUCT IS IN USE IN THE UNITED STATES.

This warranty gives you specific legal rights, and you may also have other rights which may vary from state to state.

Sears, Roebuck and Co., D817WA, Hoffman Estates, IL 60179



## SAFETY RULES



**Look for this symbol to point out important safety precautions. It means--- ATTENTION!!! Become alert!!! Your safety is involved.**

**CAUTION:** Always disconnect spark plug wire and place wire where it cannot contact spark plug to prevent accidental starting when setting-up, transporting, adjusting or making repairs.

**IMPORTANT:** Safety standards require operator presence controls to minimize the risk of injury. Your snow thrower is equipped with such controls. Do not attempt to defeat the function of the operator presence control under any circumstances.

### TRAINING

1. Read the operator's manual carefully. Be thoroughly familiar with the controls and the proper use of the snow thrower. Know how to stop the snow thrower and disengage the controls quickly.
2. Never allow children to operate the snow thrower and keep them away while it is operating. Never allow adults to operate the snow thrower without proper instruction. Do not carry passengers.
3. Keep the area of operation clear of all persons, particularly small children and pets.
4. Exercise caution to avoid slipping or falling, especially when operating in reverse.



### California Proposition 65

**WARNING:** The engine exhaust from this product contains chemicals known to the State of California to cause cancer, birth defects or other reproductive harm.

## PREPARATION

1. Thoroughly inspect the area where the snow thrower is to be used and remove all doormats, sleds, boards, wires and other foreign objects.
2. Disengage all clutches before starting the engine (motor).
3. Do not operate the snow thrower without wearing adequate winter outer garments. Wear footwear that will improve footing on slippery surfaces.
4. Handle fuel with care; it is highly flammable.
  - (a) Use an approved fuel container.
  - (b) Never remove fuel tank cap or add fuel to a running engine or hot engine.
  - (c) Fill fuel tank outdoors with extreme care. Never fill fuel tank indoors.
  - (d) Replace fuel tank cap securely and wipe up spilled fuel.
  - (e) Never store fuel or snow thrower with fuel in the tank inside of a building where fumes may reach an open flame or spark.
  - (f) Check fuel supply before each use, allowing space for expansion as the heat of the engine (motor) and/or sun can cause fuel to expand.
5. Use extension cords and receptacles as specified by the manufacturer for all snow throwers with electric drive motors or electric starting motors.
6. Adjust the snow thrower height to clear gravel or crushed rock surfaces.
7. Never attempt to make any adjustments while the engine (motor) is running (except when specifically recommended by the manufacturer).
8. Let engine (motor) and snow thrower adjust to outdoor temperatures before starting to clear snow.
9. Always wear safety glasses or eye shields during operation or while performing an adjustment or repair to protect eyes from foreign objects that may be thrown from the snow thrower.
4. discharge opening at all times.
4. Exercise extreme caution when operating on or crossing gravel drives, walks, or roads. Stay alert for hidden hazards or traffic.
5. After striking a foreign object, stop the engine (motor), remove the wire from the spark plug, disconnect the cord on electric motors, thoroughly inspect the snow thrower for any damage, and repair the damage before restarting and operating the snow thrower.
6. If the snow thrower should start to vibrate abnormally, stop the (motor) and check immediately for the cause. Vibration is generally a warning of trouble.
7. Stop the engine (motor) whenever you leave the operating position, before unclogging the auger/impeller housing or discharge guide, and when making any repairs, adjustments, or inspections.
8. When cleaning, repairing, or inspecting, make certain the auger/impeller and all moving parts have stopped. Disconnect the spark plug wire and keep the wire away from the plug to prevent accidental starting.
9. Take all possible precautions when leaving the snow thrower unattended. Disengage the auger/impeller, stop engine, and remove key.
10. Do not run the engine indoors, except when starting the engine and for transporting the snow thrower in or out of the building. Open the outside doors; exhaust fumes are dangerous (containing CARBON MONOXIDE, an ODORLESS and DEADLY GAS).
11. Do not clear snow across the face of slopes. Exercise caution when changing direction on slopes. Do not attempt to clear steep slopes.
12. Never operate the snow thrower without proper guards, plates or other safety protective devices in place.
13. Never operate the snow thrower near glass enclosures, automobiles, window wells, drop-offs, and the like without proper adjustment of the snow discharge angle. Keep children and pets away.

## OPERATION

1. Do not operate this machine if you are taking drugs or other medication which can cause drowsiness or affect your ability to operate this machine.
2. Do not use this machine if you are mentally or physically unable to operate this machine safely.
3. Do not put hands or feet near or under rotating parts. Keep clear of the
14. Do not overload the machine capacity by attempting to clear snow at too fast a rate.
15. Never operate the snow thrower at high transport speeds on slippery surfaces. Look behind and use care when backing.

- 16. Never direct discharge at bystanders or allow anyone in front of the snow thrower.
- 17. Disengage power to the auger/impeller when snow thrower is transported or not in use.
- 18. Use only attachments and accessories approved by the manufacturer of the snow thrower (such as tire chains, electric start kits, etc).
- 19. Never operate the snow thrower without good visibility or light. Always be sure of your footing, and keep a firm hold on the handles. Walk; never run.

- 4. Maintain or replace safety and instruction labels, as necessary.
- 5. Run the snow thrower a few minutes after throwing snow to prevent freeze-up of the auger/impeller.

**⚠ WARNING:** This snow thrower is for use on sidewalks, driveways and other ground level surfaces.

Caution should be exercised while using on steep sloping surfaces. **DO NOT USE SNOW THROWER ON SURFACES ABOVE GROUND LEVEL** such as roofs of residences, garages, porches or other such structures or buildings.

**MAINTENANCE AND STORAGE**

- 1. Check shear bolts and other bolts frequently for proper tightness to be sure the snow thrower is in safe working condition.
- 2. Never store the snow thrower with fuel in the fuel tank inside a building where ignition sources are present such as hot water and space heaters, clothes dryers, and the like. Allow the engine to cool before storing in any enclosure.
- 3. Always refer to operator's manual instructions for important details if the snow thrower is to be stored for an extended period.



**Contents of Parts Bag**

- 1 - Owner's Manual (not shown)
- 2 - Parts Bags (not shown)
- \* Non-Assembly Parts are found in your Tool Box located on top of your belt cover.



2 - 5/16 In. Hex Nuts



\*2 - Spare Spacers

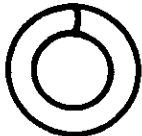

2 - 5/16 In. Lockwashers



2 - 5/16-18 x 2 In. Screws

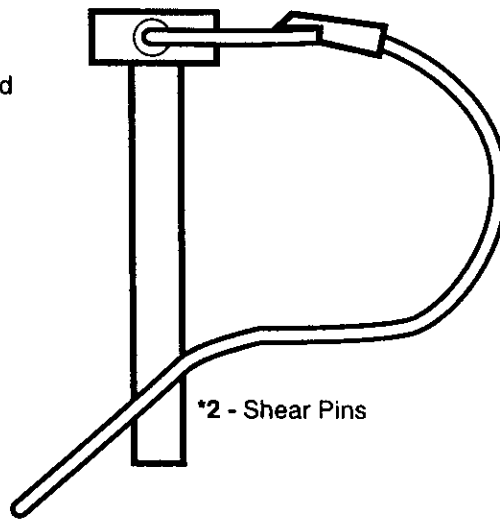

\*2 - Shear Pins

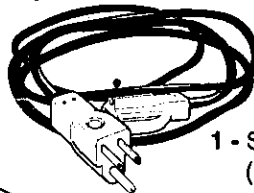

1 - Starter Motor Cord (not shown actual size)

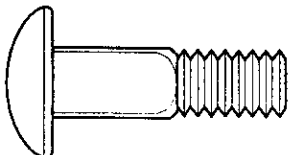

3 - Carriage Bolts, 5/16-18x1.00 In.

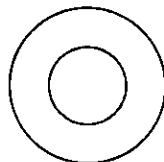

5 - Flatwashers 11/32 In.



3 -Hex Nylon Nuts, 5/16-18

**Parts packed separately in carton (not shown full size)**

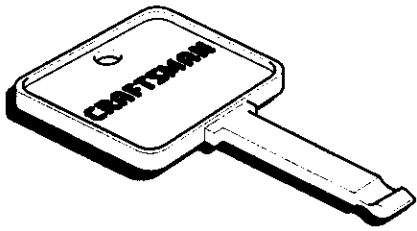

2 - Ignition Keys  
(Attached to engine in plastic bag)



1 - Container 5W30 oil



1 - Container fuel stabilizer

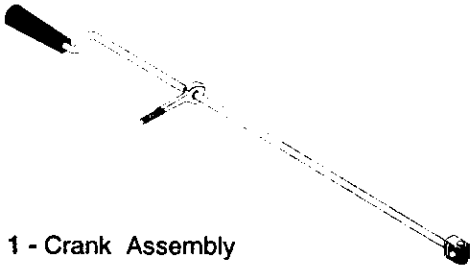

1 - Crank Assembly



1 - Snow Chute Assembly

**ASSEMBLY**

**CAUTION:** Always wear safety glasses or eye shields while assembling snow thrower.

**TOOLS REQUIRED FOR ASSEMBLY**

- 1 - Knife (to cut carton and plastic ties)
- 2 - 1/2 inch wrenches (or adjustable wrenches)
- 2 - 9/16 inch wrenches (or adjustable wrenches)
- 2 - 3/4 inch wrenches (or adjustable wrenches)
- 1 - Pliers (to spread cotter pin)
- 1 - Screwdriver
- 1 - Measuring tape or ruler

The figure below shows the snow thrower in the shipping position.

The figure to the right shows the snow thrower completely assembled.

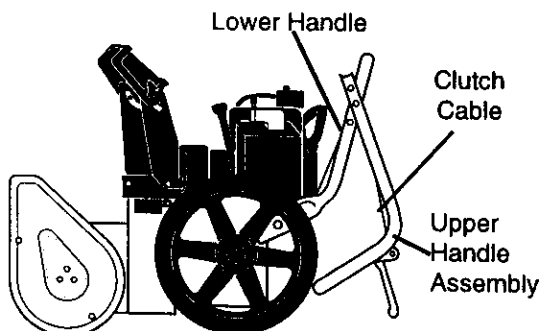

Reference to the right or left hand side of the snow thrower is from the operator's position behind the unit.

**TO REMOVE SNOW THROWER FROM CARTON**

- Locate all parts packed separately (as shown above) and remove from carton.
- NOTE:** Place fuel stabilizer in a safe place until needed for storage.

Auger drive lever

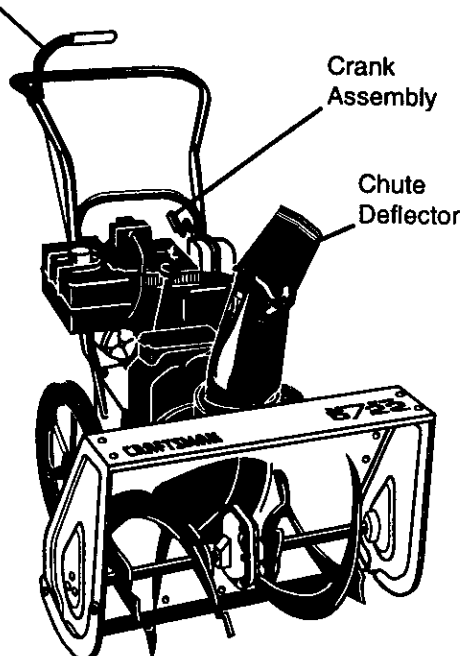

- Remove and discard the packing material from around the snowthrower.
- Cut all four corners of the carton from top to bottom and lay the panels flat.
- Cut ties securing the clutch control cable to the lower handle and lay cable back away from the motor frame.
- Standing at rear, tilt snowthrower forward and remove packaging under motor frame. **NOTE:** Be careful not to pull auger drive cable from motor frame.
- Roll the snowthrower off the carton by pulling on the lower handle. **Caution: Do not back over cable.**
- Remove the packing material from handle assembly and plastic protector on top of auger housing.

**NOTE:** If the cables have become disconnected from the clutch lever, reinstall the cables as shown in the figures below.

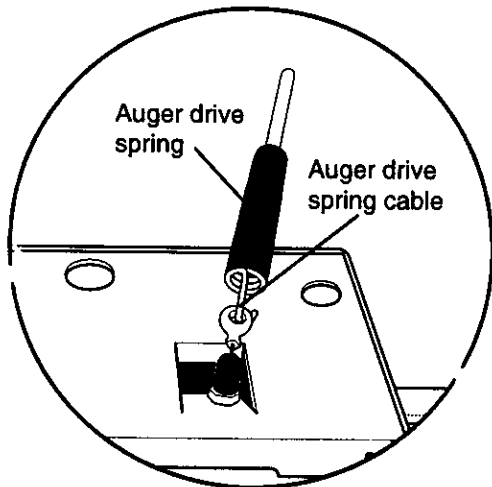
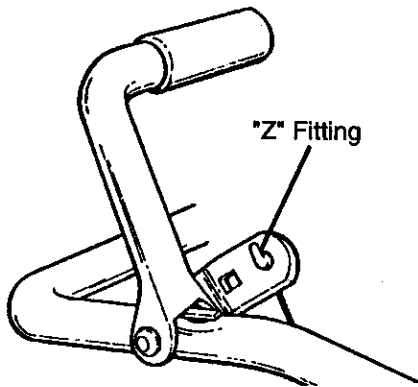

### TO INSTALL THE UPPER HANDLE AND CRANK ASSEMBLY

- Loosen, but do not remove, the screws, flatwashers, lockwashers, and hex nuts in the upper holes of the lower handle, (see first figure on next column).

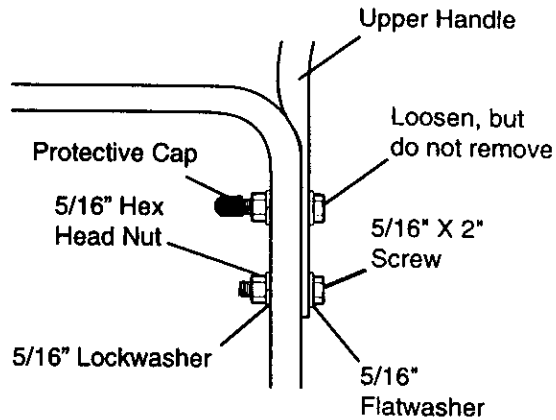

- Raise upper handle into operating position.
- Using the hardware (screws, flatwashers, lockwashers, and hex head nuts found in parts bag), attach the upper and lower handle in the lower holes. Do not tighten until all screws are in place (see figure above).
- Tighten four handle bolts.

**NOTE:** Make sure the cable is not caught between the upper and lower handle. Also make sure cable is not wrapped or tangled around handles.

- Remove the 3/8" nylon locknut and flatwasher from the eye bolt assembly (on the chute crank assembly removed earlier) (see figure below).
- Install eye bolt through lower hole in the left hand side of the handle (see figure below).
- Install the 3/8" flatwasher and the 3/8" nylon locknut loosely on the eye bolt as shown below.

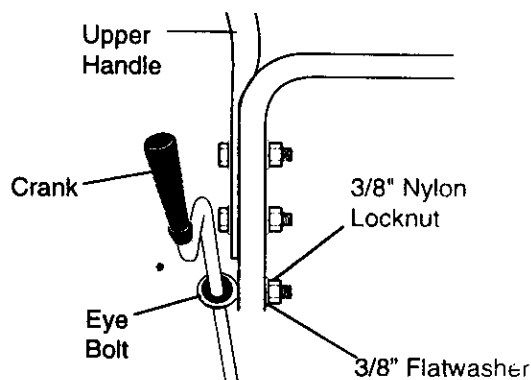

- Carefully remove cotter pin, clevis pin and drilled pin from yoke end of crank rod assembly (see figure below).
- Place universal joint into end of worm gear lining up large holes. Insert drilled pin (ensure opening in pin is in line with small openings in universal joint) (see figure below).
- Place yoke end of crank rod around universal joint, lining up openings. Insert clevis pin through assembly and secure with cotter pin. Spread ends of cotter pin to lock in place (see figure below).
- Tighten nut on eye bolt, keeping eye in line with the rod while tightening the inside securely.

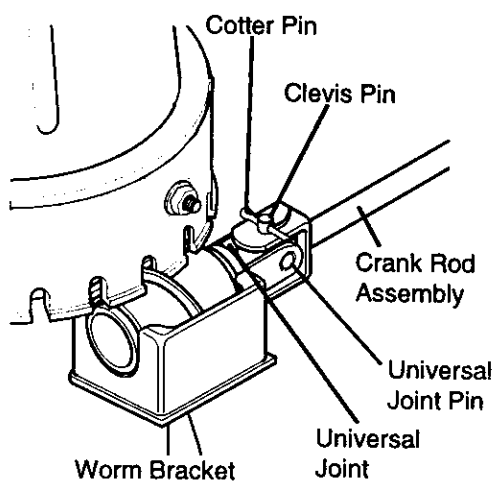

### TO ASSEMBLE SNOW CHUTE

- Turn crank assembly counterclockwise until it stops.
- Locate three carriage bolts, flatwashers and nuts (found in parts bag).
- Position snow chute on snow chute flange and align the three holes in the snow chute with holes in the snow chute flange as shown in next figure.
- Install carriage bolts from inside of chute as shown in next figure, flatwashers and nuts.
- Tighten carriage bolts securely. Be careful not to overtighten.
- Turn crank assembly clockwise and make sure all carriage bolts are tight.

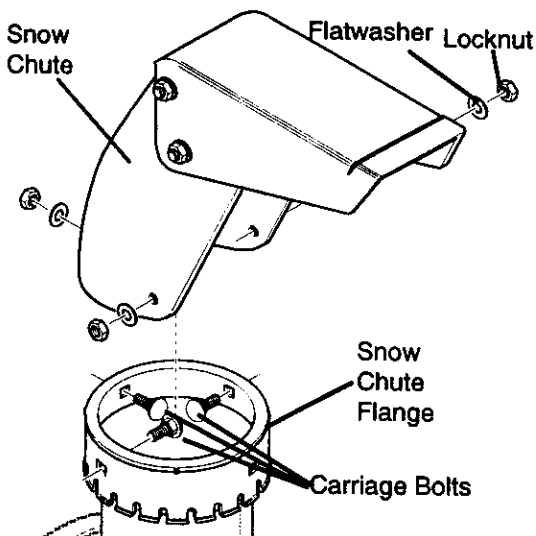

### TO CHECK/ADJUST CLUTCH CONTROL CABLE

The control cable, see figure below, attached to the auger clutch lever may need to be adjusted before you use your snow thrower.

For instructions on checking or adjusting the control cable, (see "To Adjust the Clutch Control Cable on page 14).

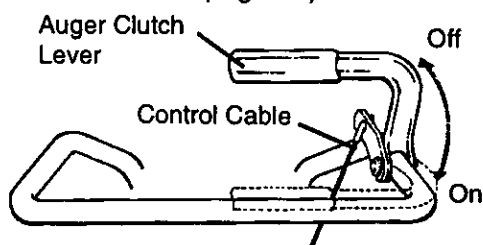

### ✓ CHECKLIST

Before you operate your new snow thrower, to ensure that you receive the best performance and satisfaction from this quality product, please review the following checklist:

- ✓ All assembly instructions have been completed.
  - ✓ The discharge chute rotates freely.
  - ✓ No remaining loose parts in carton.
- While learning how to use your snow thrower, pay extra attention to the following important items:
- ✓✓ Engine oil is at proper level.
  - ✓✓ Make sure gas tank is filled properly with clean, fresh, unleaded gasoline.
  - ✓✓ Become familiar with all controls-their location and function. Operate controls before starting engine.

## OPERATION

### KNOW YOUR SNOW THROWER

READ THIS OWNER'S MANUAL AND SAFETY RULES BEFORE OPERATING YOUR SNOW THROWER. Compare the illustrations with your SNOW THROWER to familiarize yourself with the location of various controls and adjustments. Save this manual for future reference.

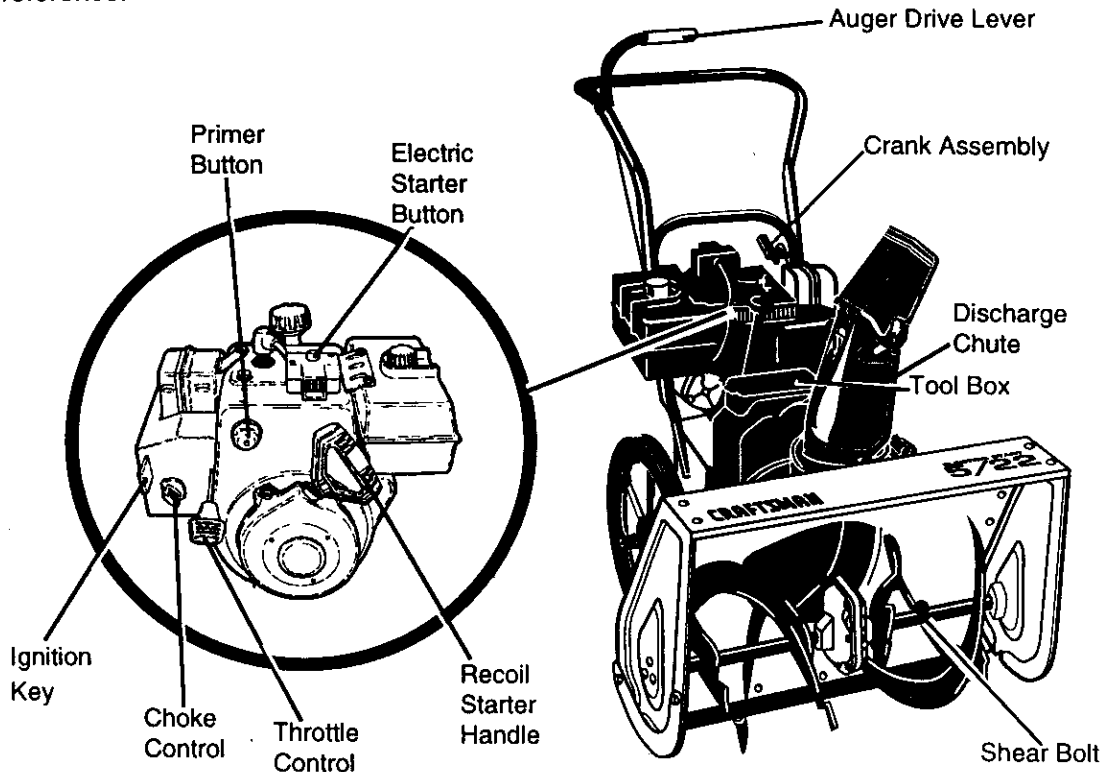

**Auger Drive Lever** – Starts and stops the auger and impeller (snow gathering and throwing). The auger assists in the self propelling.

**Crank Assembly** – Changes the direction of snow throwing through the discharge chute.

**Chute Deflector** – Changes the distance the snow is thrown.

**Discharge Chute** – Changes the direction the snow is thrown.

**Ignition Key** – Must be inserted to run, pull out to stop.

**Electric Starter Button** – Used to start the engine using the 120 V. electric starter.

**Recoil Starter Handle** – Starts the engine manually.

**Choke Control** – Used to start a cold engine.

**Primer Button** – Injects fuel directly into the carburetor manifold for fast starts in cold weather.

**Throttle Control** – Controls the engine speed.

**Shear Bolt** – Designed to break (to protect the machine) if an object becomes lodged in the auger housing. Use of a harder bolt will destroy the protection provided by the shear bolt.

**Toolbox** – Spare shear pins and spacers are located in toolbox.

These symbols may appear on your unit. Learn and understand their meaning.

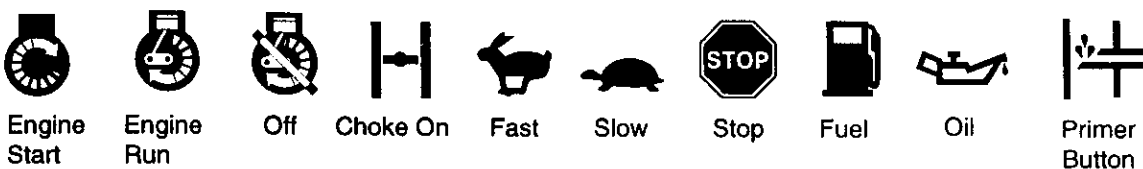

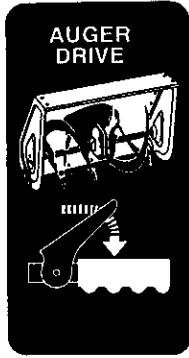

Auger Drive Clutch

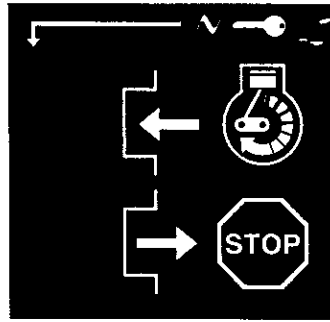

Ignition Key insert to run pull out to stop

**CAUTION:** Read owner's manual before operating machine. Never direct discharge toward bystanders. Release the auger control bar and stop the engine before unclogging discharge chute or auger housing and before leaving the machine.

The operation of any snow thrower can result in foreign objects being thrown into the eyes, which can result in severe eye damage. Always wear safety glasses or eye shields while operating the snow thrower.

We recommend standard safety glasses or a wide vision safety mask for over your glasses, available at Craftsman Retail Stores or Service Centers.

## HOW TO USE YOUR SNOW THROWER

### TO STOP YOUR SNOW THROWER

- To stop throwing snow, release the auger drive lever (see bottom right figure on this page).
- To stop the engine, push the throttle control lever to  (Stop) and pull out the ignition key (see figure below).

**NOTE:** Do Not turn key.

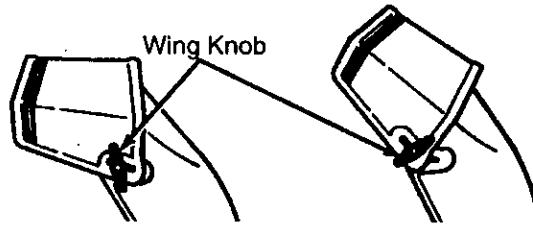
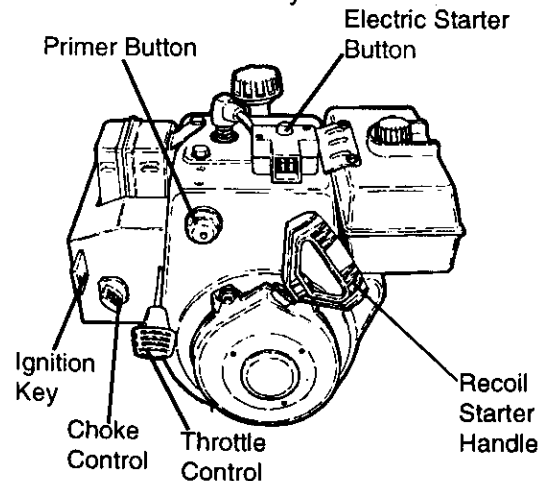

### TO CONTROL SNOW DISCHARGE

- Turn the crank assembly to set the direction of the snow throwing.
- Loosen the wing knob on the chute deflector and move the deflector to set the distance. Move the deflector (Up) for more distance, (Down) for less distance. Then tighten the wing knob (see figure above).

### TO MOVE FORWARD

- Push down the auger drive lever (see figure below). The auger will assist in self propelling the unit.
- To reduce the forward drive motion, push down on the handle, lifting the auger housing.

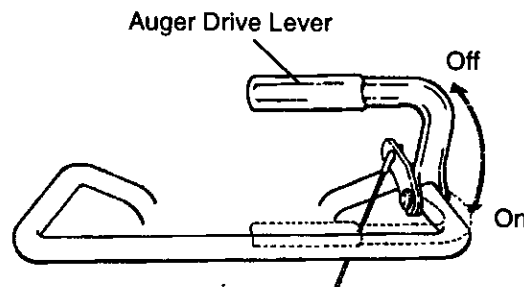

### TO THROW SNOW

- Push down the auger drive lever (see figure above).
- Release to stop throwing snow.

## BEFORE STARTING THE ENGINE

- If the snow thrower must be moved without the aid of the engine, it is easier to pull the snow thrower by the handles rather than pushing.
- Before you service or start the engine, familiarize yourself with the snow thrower. Be sure you understand the function and location of all controls.

**NOTE:** Check tension of clutch cables before starting the engine (see To Adjust The Control Cables paragraph on page 14).

- Be sure that all fasteners are tight.

## FILL OIL

**NOTE:** Engine may already contain some residual oil. Check frequently when filling the crankcase. **DO NOT OVERFILL.**

This snow thrower was shipped with a container of 5W30 motor oil. This oil must be added to the engine before operating. Remove the oil fill cap/dipstick and fill the crankcase to (Full) line on dipstick (20 ounces) (see figure below).

Tighten the fill cap/dipstick securely each time you check the oil level.

For extreme cold operating conditions of 0°F and below, use a partial synthetic 0W30 motor oil for easier starting.

## FILL GAS

**NOTICE:** ENGINES WHICH ARE CERTIFIED TO COMPLY WITH CALIFORNIA AND US EPA EMISSION REGULATIONS FOR ULGE ENGINES: Are certified to operate on regular unleaded gasoline. Include the following emission control system(s): EM, TWC (if so equipped). Include any user adjustable features - therefore no other adjustments are needed.

Fill the fuel tank with a fresh, clean, unleaded regular, unleaded premium, or reformulated automotive gasoline only. **DO NOT** use leaded gasoline. Be sure that the container you pour the gasoline from is clean and free from rust or other foreign particles. Never use gasoline that may be stale from long periods of storage in the container.

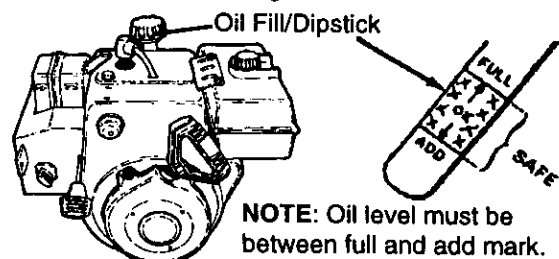

**WARNING:** Experience indicates that alcohol blended fuels (called gasohol or those using ethanol or methanol) can attract moisture which leads to separation and formation of acids during storage. Acidic gas can damage the fuel system of an engine while in storage. To avoid engine problems, the fuel system should be emptied before storage for 30 days or longer. Start the engine and let it run until the fuel lines and carburetor are empty. Use the carburetor bowl drain to empty residual gasoline from the float chamber. Use fresh fuel next season (see Storage instructions on page 17 for additional information).

Never use engine or carburetor cleaner products in the fuel tank or permanent damage may occur.

## TO STOP ENGINE

- To stop engine, move the throttle control lever to  (Stop) position and remove key. Keep the key in a safe place. The engine will not start without the key.

## TO START ENGINE (Electric Starter)

Be sure that the engine has sufficient oil. The snow thrower engine is equipped with a 120 volt A.C. electric starter and recoil starter. Before starting the engine, be certain that you have read the following information:

**CAUTION:** Never run engine indoors or in enclosed, poorly ventilated areas. Engine exhaust contains CARBON MONOXIDE, AN ODORLESS AND DEADLY GAS. Keep hands, feet, hair and loose clothing away from any moving parts on engine and snow thrower.



**WARNING:** Temperature of muffler and nearby areas may exceed 150° F. Avoid these areas.

**DO NOT** allow children or young teenagers to operate or be near snow thrower while it is operating.

**CAUTION:** Do not attempt to remove any item that may become lodged in auger without taking the following precautions:

- Release auger drive lever.
- Move throttle lever to stop position.
- Remove (**Do Not Turn**) ignition key.
- Disconnect spark plug wire.
- Do not place your hands in the auger or discharge chute. Use a pry bar.

### COLD START (See figure on this page)

- Be sure the auger drive lever is in the disengaged (Released) position.
- Move the throttle control to  (Fast) position.
- Remove the keys from the plastic bag. Insert one key into the ignition slot. Be sure it snaps into place. **DO NOT TURN KEY**. Keep the second key in a safe place.
- Rotate the choke control to  choke ON position.
- Connect the power cord to the switch box on the engine.
- Plug the other end of the power cord into a three-hole, grounded 120 volt A.C. receptacle.
- Push the primer button while covering the vent hole as follows: (remove finger from primer button between primes).  
Do not prime if temperature is above 50°F.  
Two times if temperature is 50°F to 15°F.  
Four times if temperature is below 15°F.
- Push down on the starter button until the engine starts. Do not crank for more than 10 seconds at a time. This electric starter is thermally protected. If overheated it will stop automatically and can be restarted only when it has cooled to a safe temperature (a wait of about 5 to 10 minutes is required).
- When the engine starts, release the starter button and move choke lever to "1/2 choke" position. When engine runs smoothly, move choke lever to "No Choke" Position.
- Disconnect the power cord from the receptacle first and from the switch box on engine.

**NOTE:** Allow the engine to warm up for several minutes before blowing snow in temperatures below 0°F.

- Run the engine at full throttle  (Fast) when throwing snow.

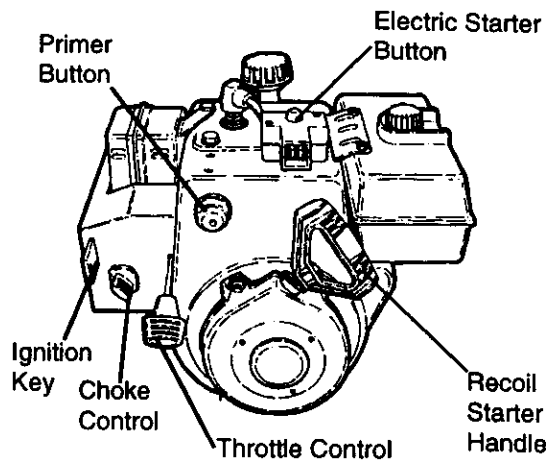

**⚠ CAUTION:** Gasoline is flammable and caution must be used when handling or storing it.

Do not fill fuel tank while snow thrower is running, when it is hot, or when snow thrower is in an enclosed area.

Keep away from open flame or an electrical spark and Do Not Smoke while filling the fuel tank.

Never fill the tank completely. Fill the tank to within 1/4" - 1/2" from the top to provide space for expansion of fuel.

Always fill fuel tank outdoors and use a funnel or spout to prevent spilling.



Make sure to wipe up any spilled fuel before starting the engine.

Store gasoline in a clean, approved container and keep the cap in place on the container.

### TO START ENGINE (Recoil Starter)

- Be sure that the engine has sufficient oil. The snowthrower engine is equipped with a recoil starter. Before starting the engine, be certain that you have read the following information:

### COLD START (See figure above)

- Be sure the auger drive lever is in the disengaged (Released) position.
- Move the throttle control to  (Fast) position.
- Remove the keys from the plastic bag. Insert one key into the ignition slot. Be sure it snaps into place. Do not turn key. Keep the second key in a safe place.
- Rotate the choke control to  choke ON position.

- Push the primer button, see figure on page 9, while covering the vent hole as follows: (remove finger from primer button between primes).
  - Do not prime if temperature is above 50°F.
  - Two times if temperature is 50°F to 15°F.
  - Four times if temperature is below 15°F.
- Pull the recoil starter handle rapidly. Do not allow the handle to snap back, but allow it to rewind slowly while keeping a firm hold on the starter handle.
- As engine starts warms up move choke lever to "1/2 choke" position. When engine runs smoothly, move choke lever to "No Choke" Position.

**NOTE:** Allow the engine to warm up for several minutes before blowing snow in temperatures below 0°F.

- Run the engine at full throttle  (Fast) when throwing snow.

## WARM START

If restarting a warm engine after a short shutdown, leave choke at (Off) and do not push the primer button. If the engine fails to start, follow the Cold Start instructions above.

## FROZEN RECOIL STARTER

If the starter is frozen and will not turn engine:

- Pull as much rope out of the starter as possible.
- Release the starter handle and let it snap back against the starter.

If the starter still fails to turn engine, repeat the two previous steps until the starter engages. Then continue with the directions for cold start.

To help prevent possible freeze-up of recoil starter and engine controls, proceed as follows after each snow removal job.

- With the engine running, pull the starter rope hard with a continuous full arm stroke three or four times. Pulling of starter rope will produce a loud clattering sound. This is not harmful to the engine or starter.
- With the engine not running, wipe all snow and moisture from the carburetor cover in area of control levers. Also move throttle control, choke control, and starter handle several times.

## SNOW THROWING TIPS

- For maximum snow thrower efficiency operate engine at (Full) throttle. The engine is designed to deliver maximum performance at full throttle and should be run at this power setting at all times.
- Most efficient snow throwing is accomplished when the snow is removed immediately after it falls.
- For complete snow removal, slightly overlap each path previously taken.
- The snow should be discharged down wind whenever possible.
- After the snow throwing job has been completed, allow the engine to idle for a few minutes, which will melt the snow and accumulated ice off the engine.
- Clean the snow thrower thoroughly after each use.
- Remove ice and snow accumulation and all debris from the entire snowthrower, and flush with water (if possible) to remove all salt or other chemicals. Wipe snow thrower dry.

# MAINTENANCE

## GENERAL RECOMMENDATIONS

The warranty on this snow thrower does not cover items that have been subjected to operator abuse or negligence. To receive full value from the warranty, the operator must maintain the snow thrower as instructed in this manual. The chart on the next page is

provided to assist the operator in properly maintaining the snow thrower.

Some adjustments will need to be made periodically to properly maintain your snow thrower.

## CUSTOMER RESPONSIBILITIES

SERVICE RECORDS Fill in dates as you complete regular service	SCHEDULE								SERVICE DATES			
	After first 2 Hours	Before Each Use	As Needed	Every 5 Hours	Every 10 Hours	Every 25 Hours	Each Season	Before Storage				
Check Engine Oil Level		✓		✓			✓					
Change Engine Oil						✓	✓					
Tighten All Screws & Nuts	✓		✓									
Lubricate Pivot Points					✓			✓				
Check Auger Clutch Cable Adjustment (See Cable Adj)	✓											
Check Drive Belt							✓					
Check Fuel		✓										
Drain Fuel								✓				
Replace Spark Plug						✓	✓					

### PRODUCT SPECIFICATIONS

HORSE POWER:	5HP
DISPLACEMENT:	12.04 cu. in.
GASOLINE CAPACITY:	2 quart (unleaded)
OIL (20 oz. Capacity) :	5W-30
SPARK PLUG:	Champion RJ19LM (Gap .030) or Equivalent
VALVE CLEARANCE:	Intake: 0.10 In. Exhaust: .010 In.

### SNOW THROWER

#### ENGINE LUBRICATION

Check the crankcase oil level (see figure below) before starting the engine and after each five (5) hours of continuous use. Add S.A.E. 5W30 motor oil as needed. Tighten fill cap/dipstick securely each time you check the oil level. S.A.E. 0W30 motor oil may be used to make starting easier in areas where the temperature is 20° F or lower.

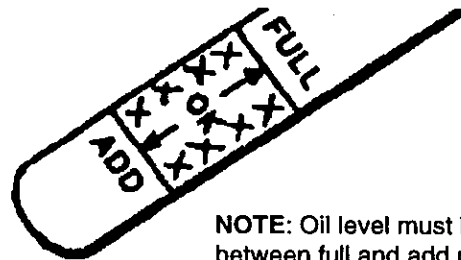

NOTE: Oil level must be between full and add mark

### SNOW THROWER

#### AFTER FIRST USE

- Check for any loose or damaged parts.
- Tighten any loose fasteners.
- Check and maintain the auger.

#### AFTER EACH USE

- Remove all snow and slush off the snow thrower to prevent freezing of auger or controls.
- Check controls to make sure they are functioning properly.
- If any parts are worn or damaged, replace immediately.

## OIL RECOMMENDATION

Only use high quality detergent oil rated with API service classification SG. Select the oil's viscosity grade according to your expected operating temperature.

**NOTE:** For extreme cold operating conditions of 0° and below, use a partial synthetic 0W30 motor oil for easier starting.

**NOTE:** Although multi-viscosity oils improve starting in cold weather, these multi-viscosity oils will result in increased oil consumption when used above 32°F. Check your engine oil level more frequently to avoid possible engine damage from running low on oil.

Change the oil every 25 hours and at the beginning of each season.

- Position the snow thrower so that the oil drain plug is at the lowest point on the engine. Remove the oil drain plug and the oil fill cap/dipstick. Drain the oil into a suitable container. Oil will drain more freely when warm.
- Replace the oil drain plug and tighten securely.

Oil Fill Cap/Dipstick

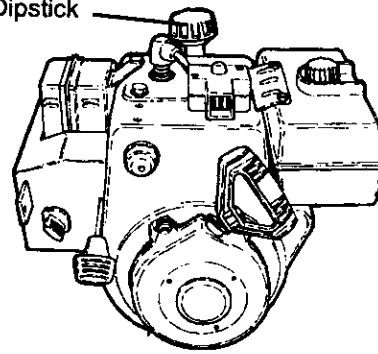

## SPARK PLUG

- Make sure that the spark plug is tightened securely into the engine and the spark plug wire is attached to the spark plug.
- If a torque wrench is available, torque plug to 18 to 23 foot pounds.
- Clean the area around the spark plug base before removal to prevent dirt from entering the engine.
- Clean the spark plug and reset the gap periodically at .030 inch.

## SERVICE AND ADJUSTMENTS

**⚠ CAUTION:** Always disconnect the spark plug wire and tie back away from the plug before making any adjustments or repairs.

### TO ADJUST THE CLUTCH CONTROL CABLE

Periodic adjustment of the cable may be required due to normal stretch and wear on the belts. To check for correct adjustment, the control lever must be in the full forward position, resting on the plastic bumper. The control cable is correctly adjusted when the center of the "Z" fitting is between the center and top of the hole in the clutch lever and there is no droop in the cable (see first figure).

If adjustment is necessary:

- Disconnect "Z" fitting from drive lever (see first figure).
- Push the cable through the spring (see second figure), to expose the threaded portion of the cable.

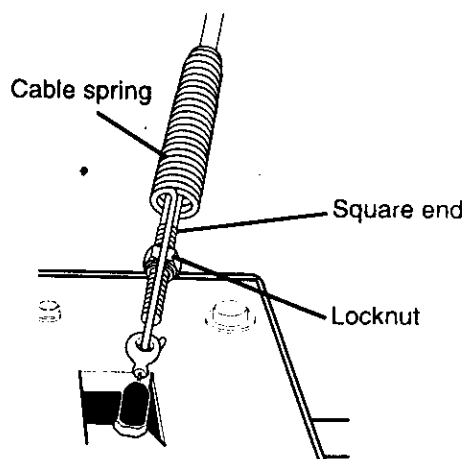
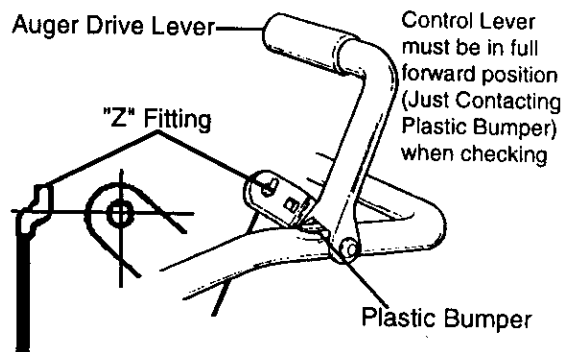

- Hold the square end of the threaded portion with pliers and adjust the locknut in or out until the excess slack is removed (see last figure on page 14).
- Pull the cable back through the spring and connect the cable (see last figure on page 14).

**NOTE:** Whenever the auger belt is replaced, the cables will need to be adjusted.

### TO ADJUST BELT

Belts stretch during normal use. If your snow thrower will not discharge snow, check the control cable adjustment. If it is correct, then check the condition of the auger drive belt, it may be loose or damaged. If it is damaged, replace it (see To Replace Belt paragraph below).

### TO REPLACE BELT

The drive belt on this snow thrower is of special construction and should be replaced with original equipment, belts are available from your nearest Craftsman Store or Service Center.

**CAUTION:** Drain the gasoline outdoors, away from the fire or flame.

If your snow thrower will not discharge snow, and the auger drive belt (see second figure on page for location) is damaged, replace it as follows:

- Disconnect the spark plug wire.

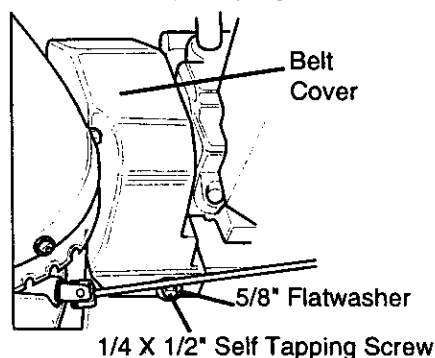

- Remove the belt cover (see figure above).
- Loosen the belt guides (see next figure) and pull away from the auger drive pulley.
- Slip belt from auger drive pulley.
- Pull auger idler pulley to the engaged position, releasing brake.
- Slip belt from between brake arm and pulley.
- Remove old belt.

- Install new replacement belt of the same type onto the auger pulley.
- Position belt onto auger drive pulley.
- Adjust belt guides (see to Adjust Belt Guides paragraph).
- Reinstall the belt cover.
- Check the clutch control cable adjustment (see paragraph on page 14).
- Reconnect spark plug wire.

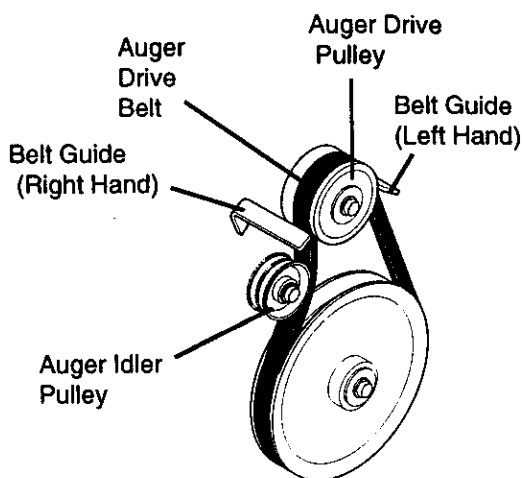

### TO ADJUST THE BELT GUIDES

- Disconnect the spark plug wire.
- Remove the belt cover by removing the screw and flatwasher on the left and right hand sides (see first figure on this page).
- Engage the auger drive clutch lever.
- Measure the distance between the belt guides and the belt (see figure below). The distance should be 3/32" for each guide.
- If adjustment is necessary, loosen the belt guide mounting bolts. Move the belt guides to the correct position. Tighten the mounting bolts.
- Reinstall the belt cover.
- Reconnect the spark plug wire.

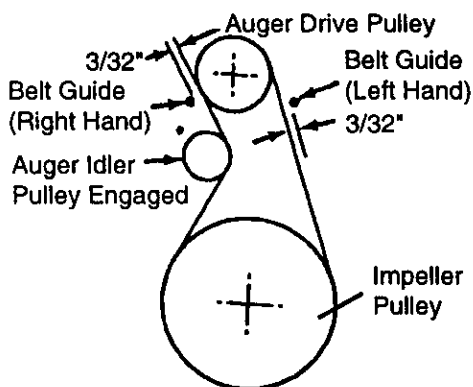

## TO REPLACE AUGER SHEAR BOLT

The augers are secured to the auger shaft with special bolts (see figure below) that are designed to break (to protect the machine) if an object becomes lodged in the auger housing. Use of a harder bolt will destroy the protection provided by the shear bolt.

**IMPORTANT:** To ensure safety and performance levels, only original equipment shear bolts should be used. When replacing shear bolts, be sure to replace shear bolt spacers.

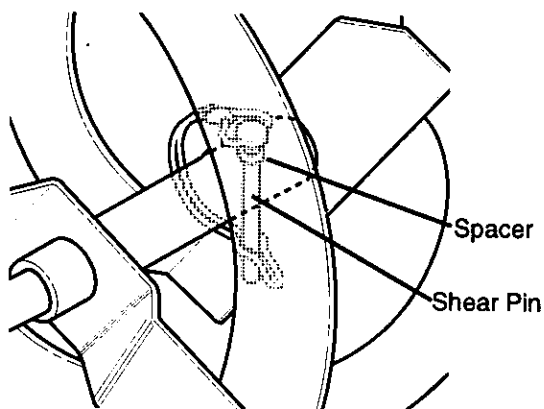

To replace a broken shear bolt, proceed as follows:

- Move the throttle to  (Stop) and turn off all controls.
- Disconnect the spark plug wire. Be sure all moving parts have stopped.
- Remove the broken shear bolt.
- Align the hole in the auger with the hole in the auger shaft. Install the new shear pin, spacer and locknut found in toolbox located on top of belt cover.
- Reconnect the spark plug wire.

## TO ADJUST CARBURETOR

If you think your carburetor needs adjusting, see your nearest Authorized Craftsman Service Center. Engine performance should not be affected at altitudes up to 7,000 feet. For operation at higher elevations, contact your Authorized Craftsman Service Center.

**IMPORTANT:** Never tamper with the engine governor, which is factory set for proper engine speed. Over speeding the engine above the factory high speed setting can be dangerous. If you think the engine-governed high speed needs adjusting, contact your nearest Craftsman Service Center, which has the proper equipment and experience to make any necessary adjustments.

## TO ADJUST OR REPLACE THE SPARK PLUG

**NOTICE:** This spark ignition system meets all requirements of the Canadian Interference-Causing Equipment Regulations.

**NOTICE:** This engine complies with all current Australian and New Zealand limitations regarding electromagnetic interference.

If you have difficulty starting your snow thrower, you may need to adjust or replace the spark plug. Follow the instructions below.

Replace the spark plug if the electrodes are pitted or burned or if the porcelain is cracked.

**To Adjust:**

- Clean the spark plug by carefully scraping the electrodes (do not sand blast or use a wire brush).
- Be sure the spark plug is clean and free of foreign material. Check the electrodes gap (see figure below) with a wire feeler gauge and reset the gap to .030 inch if necessary.

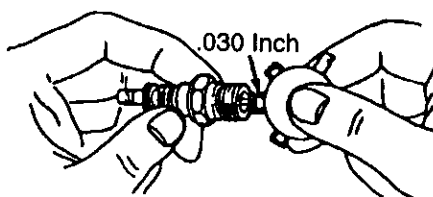

**To Replace:**

- If you need a new spark plug, use only the proper replacement spark plug (see page 13).
- Set the gap to .030 inch.
- Before installing the spark plug, coat its threads lightly with oil or grease to insure easy removal.
- Tighten the plug firmly into the engine.
- If a torque wrench is available, torque the plug to 18 to 23 ft. - lbs.

## STORAGE

**⚠ CAUTION:** Never store your snow thrower indoors or in an enclosed, poorly ventilated area if gasoline remains in the tank. fumes may reach an open flame, spark or pilot light from a furnace, water heater, clothes dryer, cigarette, etc.

To prevent engine damage (if snow thrower is not used for more than 30 days) follow the steps below.

### SNOW THROWER STORAGE

- Thoroughly clean the snow thrower.
- Lubricate all lubrication points (see the Maintenance section on pages 12-14).
- Be sure that all nuts, bolts and screws are securely fastened. Inspect all visible moving parts for damage, breakage and wear. Replace if necessary.
- Touch up all rusted or chipped paint surfaces; sand lightly before painting.
- Cover the bare metal parts of the blower housing auger and the impeller with rust preventative, such as a spray lubricant.

**NOTE:** A yearly checkup or tune-up by a Craftsman Service Center is a good way to insure that your snow thrower will provide maximum performance for the next season.

### ENGINE STORAGE

Gasoline must be removed or treated to prevent gum deposits from forming in the tank, filter, hose, and carburetor during storage. Also during storage, alcohol blended gasoline that uses ethanol or methanol (Sometimes called gasohol) attracts water. It acts on the gasoline to form acids which damage the engine.

- To remove gasoline, run the engine until the tank is empty and the engine stops. Then drain remaining gasoline from carburetor by pressing upward on bowl drain located on the bottom of carburetor (see figure on right).

- If you do not want to remove gasoline, use fuel stabilizer supplied with unit or purchase Craftsman Fuel Stabilizer No. 33500. Add fuel stabilizer to any gasoline left in the tank to minimize gum deposits and acids. If the tank is almost empty, mix stabilizer with fresh gasoline in a separate container and add some to the tank.

Always follow instructions on stabilizer container. Then run engine at least 10 minutes after stabilizer is added to allow mixture to reach carburetor. Store snow thrower in a safe place. See Warning above.

You can keep your engine in good operating condition during storage by:

- Changing oil (see page 10).
- Lubricating the piston/cylinder area. This can be done by first removing the spark plug and squirting a few drops of clean engine oil into the spark plug hole. Then cover the spark plug hole with a rag to absorb oil spray. Next, rotate the engine by pulling the starter rope fully out two or three times. Finally, reinstall spark plug and attach spark plug wire.

### OTHER

- If possible, store your snow thrower indoors and cover it to give protection from dust and dirt.
- If the machine must be stored outdoors, block up the snow thrower to be sure the entire machine is off the ground.
- Cover the snow thrower with a suitable protective cover that does not retain moisture. Do not use plastic or vinyl.

**IMPORTANT:** Never cover snow thrower while engine and exhaust areas are still warm.

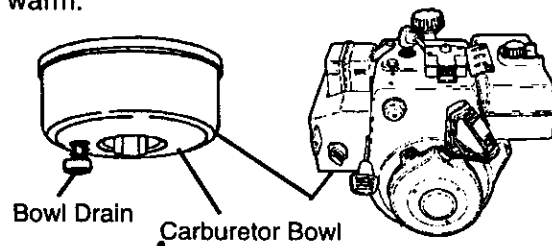

## TROUBLE SHOOTING

TROUBLE	CAUSE	CORRECTION
<b>Difficult starting</b>	Defective spark plug Water or dirt in fuel system	Replace spark plug Use carburetor bowl drain to flush and refill with fresh fuel.
<b>Engine runs erratically</b>	Blocked fuel line or low on fuel tank or stale gasoline	Clean fuel line; check fuel supply; add fresh fuel (gasoline/oil mixture if 2-cycle engine).
<b>Engine stalls</b>	Unit running on CHOKE	Move choke lever to OFF position.
<b>Engine runs erratically; or Loss of power</b>	Water or dirt in fuel system	Use carburetor bowl, drain to flush & refill with fresh fuel.
<b>Excessive vibration</b>	Loose parts; damaged impeller	Stop engine immediately and disconnect spark plug wire. Tighten all bolts and make all necessary repairs. If vibration continues, have the unit serviced by a Craftsman service repairman.
<b>Units fails to propel itself</b>	Side plates touching ground  Auger drive belt loose or damaged  Auger control cable not adjusted correctly  Shear bolt broken	Adjust side plates. See to Adjust Side Plates in the Adjustment section.  Check auger drive belt, replace if necessary.  Adjust auger control cable.  Replace with shear pin found in tool box located on belt cover.
<b>Unit fails to discharge snow</b>	Discharge chute clogged  Foreign object lodged in auger	Stop engine immediately and disconnect spark plug wire. Clean discharge chute and inside of auger housing.  Stop engine immediately and disconnect spark plug wire. Remove object from auger.



**CRAFTSMAN 22" - 5H.P. SNOW THROWER 536.884790**  
**ELECTRIC START ASSEMBLY**

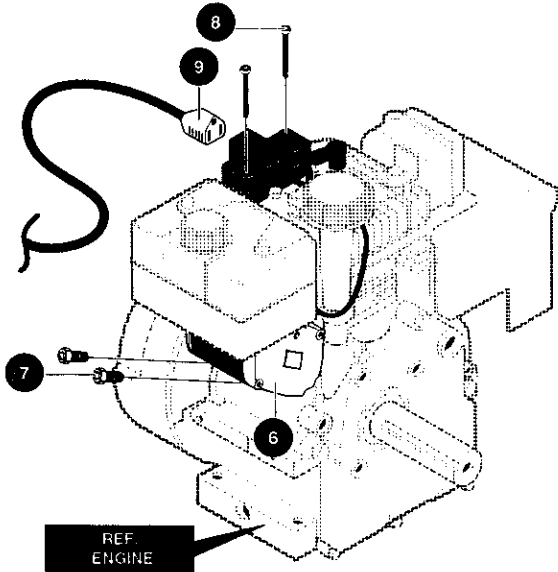

REF NO.	PART NO.	PART NAME
6	330783	Motor, Electric Starter
7	6216	Screw, 1/4-20x.50
8	6217	Screw, #6-32x2.50
9	6219	Cord, Starter Motor
	760985	Owner's Manual

319051 B

**ENGINE ASSEMBLY**

**NOTE**

ENGINE MOUNTS TO FRONT HOLES ON THE FRAME

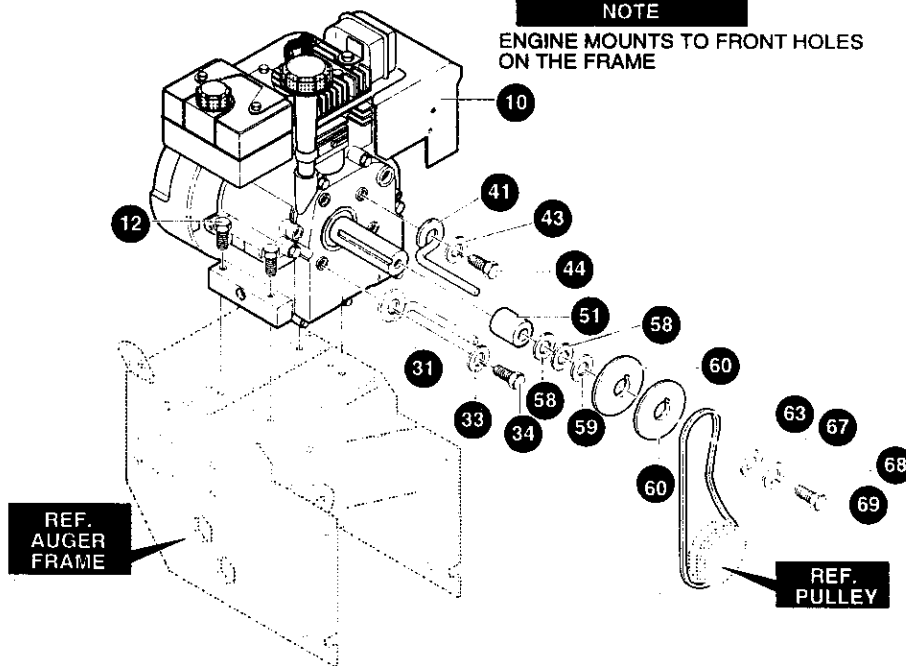

336629 D

REF NO.	PART NO.	PART NAME
10	Engine	Model 143.985003 (see Engine Parts List)
12	710024	Screw, 5/16-18
31	3949	Guide, Rod Belt, RH
33	120638	Washer, .328x.60x.09
34	910828	Screw, 5/16-24x.625
41	3949	Guide, Rod Belt RH
43	120638	Washer, .328x.60x.09
44	910828	Screw, 5/16-24x.625

REF NO.	PART NO.	PART NAME
51	57479	Spacer, Slev .75x1.25x1.32
58	73840	Flatwasher .765x1.12x.06
59	58625J	Spacer, Slev .753x1.12x.38
60	586253	Pulley, Eng V4L 3.00x.75
63	581264	Belt, V 4L 35.23Lg.
67	313826	Flatwasher
68	120382	Washer, Regsptlk
69	39573	Screw, 3/8-24x1.00

**Note: Always use original equipment parts.** Use of service/replacement parts other than original parts may void your warranty.

**All unnumbered items are interchangeable with opposite side**

**CRAFTSMAN 22" - 5H.P. SNOW THROWER 536.884790**  
**FRAME COMPONENTS ASSEMBLY**

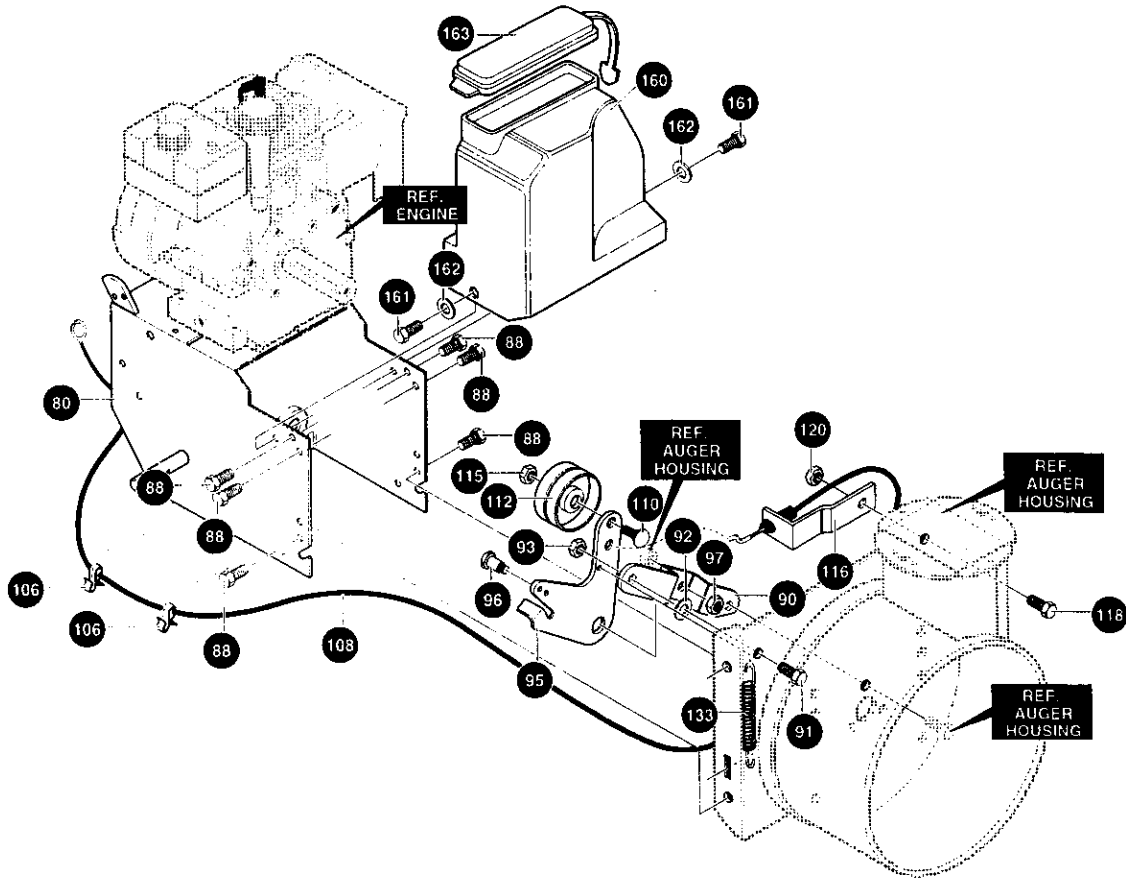

REF NO.	PART NO.	PART NAME
80	340673-833	Frame Assy
88	782967	Screw, 5/16-18x.88
90	761195	Plate-Clutch Arm
91	71003	Screw, 3/8-16x.75
92	120382	Washer, Regsptlk
93	1499	Nut, 3/8-16
95	761198	Arm-Clutch
96	710020	Bolt, .497x.138 3/8-16
97	1499	Nut, 3/8-16 Reghexctrik
106	340682	Clip, Cable
108	761153	Cable, Auger Clutch Ctrl

REF NO.	PART NO.	PART NAME
110	180124	Screw, 3/8-16x1.25
112	313843	Pulley, Idler
115	41529	Nut, 3/8-16 Hexctrlkjam
116	340579	Bracket, Compact Cable
118	71003	Screw, 3/8-16x1.25
120	1499	Nut, 3/8-16 Reghexctrik
133	313854	Spring, Idler
160	760478	Cover, Belt w/Storage
161	310169	Screw, 1/4-20x.63
162	120392	Flatwasher, .281x.63x.065
163	760539	Lid, Belt Cover Tool Box

342576B



**CRAFTSMAN 22" - 5H.P. SNOW THROWER 536.884790**

**GEAR CASE ASSEMBLY**

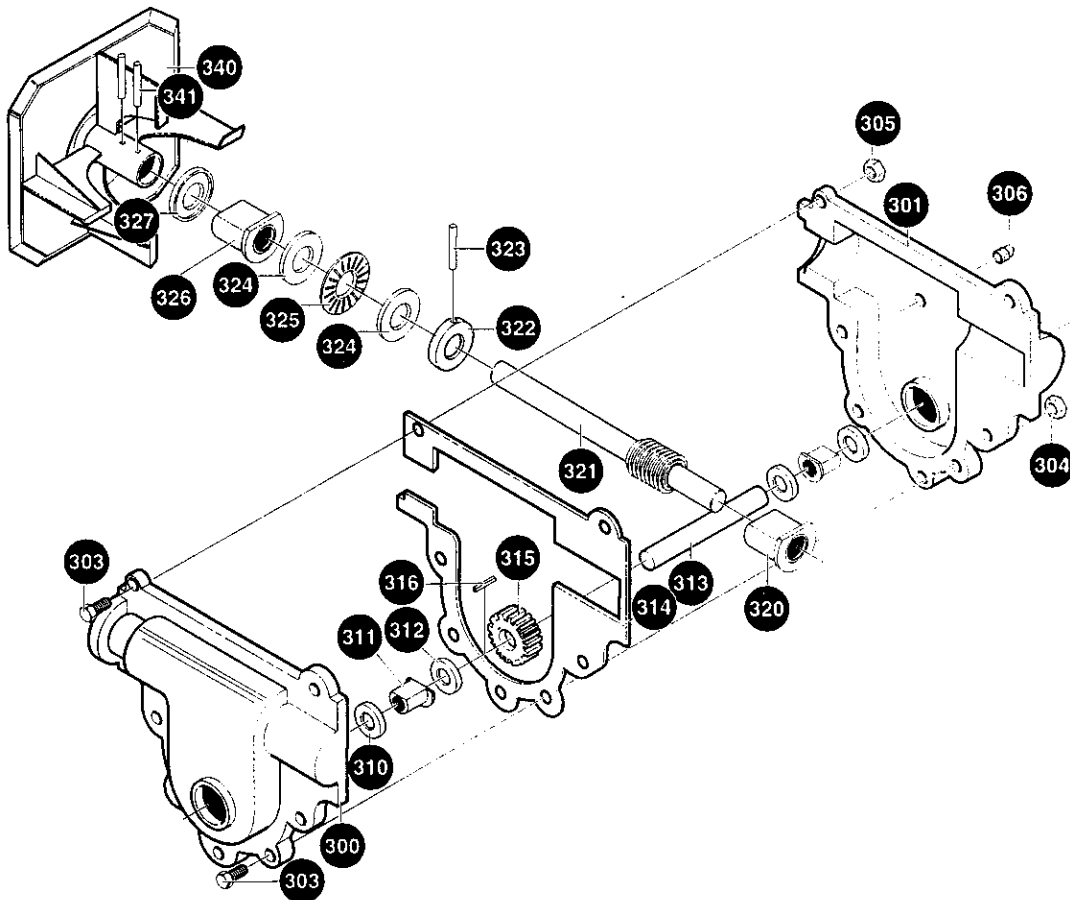

REF NO.	PART NO.	PART NAME	REF NO.	PART NO.	PART NAME
300	10577	Gear Case, RH	316	431787	Key, Woodruff
301	10576	Gear Case, LH	320	50221	Bearing, Flange
303	710025	Screw, 1/4-20x.75	321	583125	Shaft, Worm Imp Input
304	46931	Nut, 1/4-20	322	580295	Collar, Thrust .753x1.24x.50
305	303008	Nut, 1/4-20 Hexkeys	323	454565 •	Pin, Spring
306	9344	Screw, 3/8-16x.50	324	48275	Flatwasher, .752x1.24x.093
310	9566	Seal, Oil	325	313828	Bearing, Roll
311	50304	Bearing, Flange	326	50304	Bearing, Flange
312	48275	Flatwasher, .752x1.24x.093	327	9566	Seal, Oil
313	340284	Shaft, Auger Output	340	760194-853	Impel, Assy
314	51279	Gasket, Gear Case	341	454565	Spring Pin
315	51405	Gear, Worm			

337653 B

# CRAFTSMAN 22" - 5H.P. SNOW THROWER 536.884790

## AUGER HOUSING ASSEMBLY

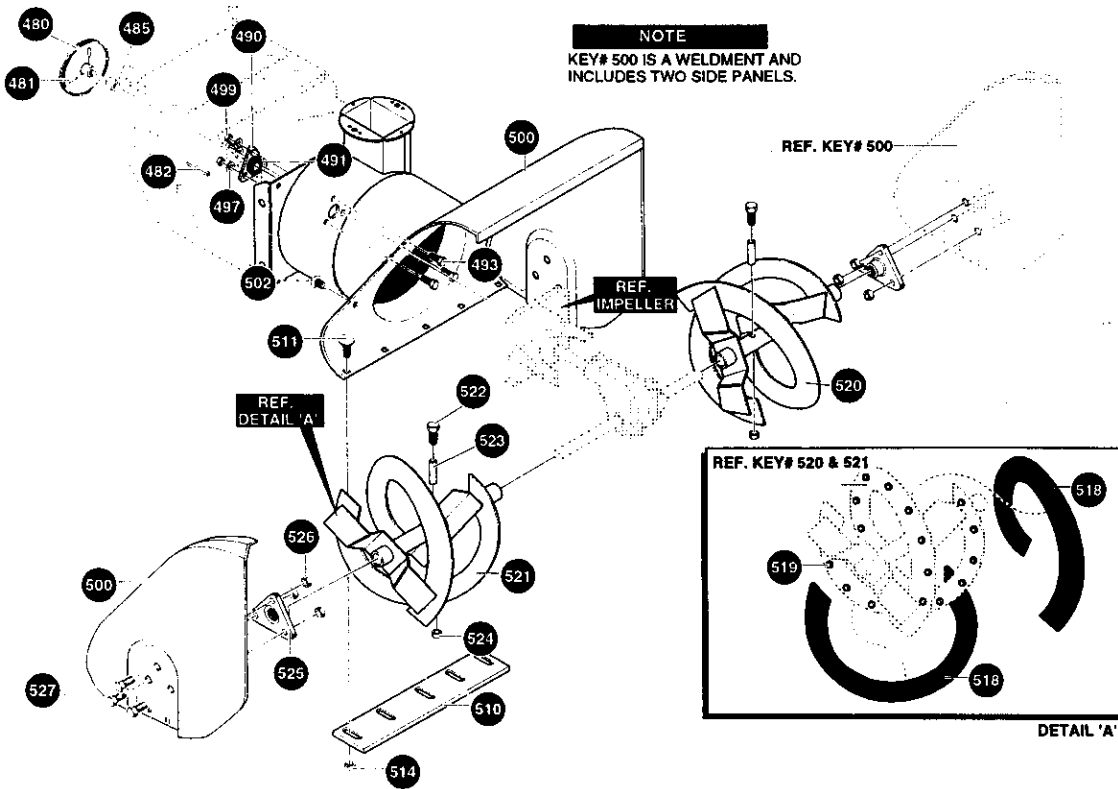

REF NO.	PART NO.	PART NAME
480	583124	Pulley, V4L
481	71002	Screw, 5/16-18x.50
482	71371	Key, Square
485	334514	Spacer, Slve .676x1.00x.53
490	582960	Retainer, Ball Bearing
491	43846	Bearing, Ball
493	180077	Screw, 5/16-18x.75
497	120638	Washer, .328x.60x.09
499	120376	Nut, 5/16-18
500	760812-833	Housing, Assy
502	309235	Ratchet Fastener
510	581395-853	Blade, Scraper 22"
511	340714	Carr. Bolt, 1/4-20x.75
514	780285	Nut, 1/4-20 Whiz-loc
518	336656	Flighting-Rubber
519	49838	Rivet, Ovset

REF NO.	PART NO.	PART NAME
520	340546-853	Auger, Assy LH
521	340547-853	Auger, Assy RH
522	121940	Screw, 1/4-20x1.75
523	3943	Spacer, Slve .250x.47x.20
524	782585	Nut, 1/4-20
525	9517	Bearing, Flange
526	8619	Nut, 5/16-18
527	9357	Screw, 5/16-18x.75

336635D

# CRAFTSMAN 22" - 5H.P. SNOW THROWER 536.884790

## CHUTE ASSEMBLY

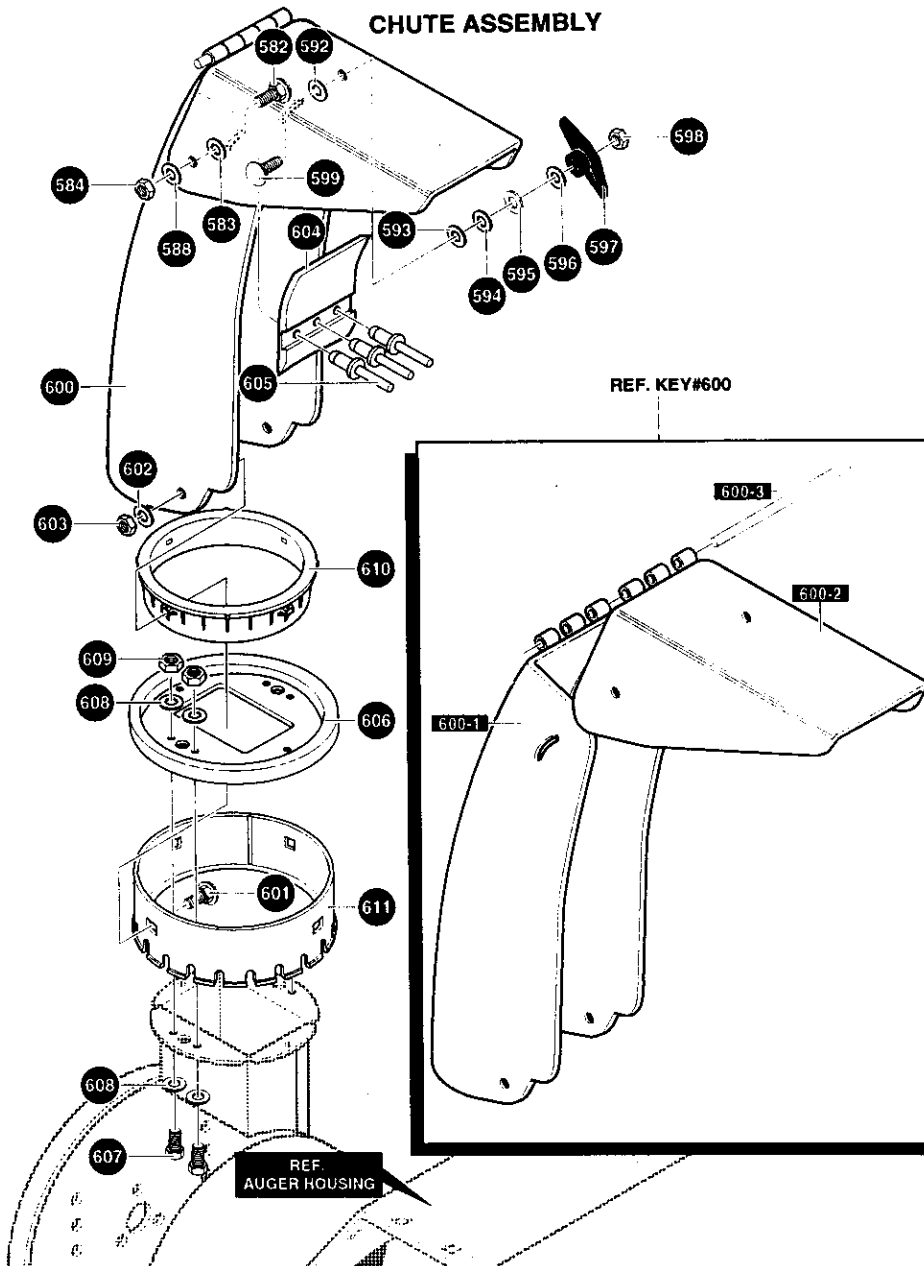

REF NO.	PART NO.	PART NAME
582	340720	Bolt, 5/16-18x.75
583	12021	Washer, Pl .438x.75x.064
584	71038	Nut, 5/16-18 Reghexctrk
588	6711	Washer, .315x.75x.064
592	12021	Washer, Pl .438x.75x.064
593	6711	Washer, .315x.75x.064
594	120393	Flatwasher .344x.69x.065
595	120638	Washer, .328x.60x.09
596	120393	Flatwasher .344x.69x.065
597	13527	Knob, T
598	120376	Nut, 5/16-18 Reghex
599	126358	Bolt, Carr. 5/16-18x1.00
600	760990-853	Chute Assembly
600-1	760989	Lower Chute
600-2	11780	Upper Chute

REF NO.	PART NO.	PART NAME
600-3	305216	Hinge Pin
601	586280	Bolt, 5/16-18x1.00
602	120393	Flatwasher, .344x.69x.065
603	71038	Nut, 5/16-18 Hexnyl
604	760268	Flap, Chute inset
605	760987	Pop Rivet
606	585214-853	Collar, Chute
607	180020	Screw, 1/4-20x.75
608	120392	Flatwasher, .281x.63x.065
609	782585	Nut, 1/4-20 Reghexctrk
610	337227	Retainer, Ring Inner
611	585193	Retainer, Ring Outer

337160 E

# CRAFTSMAN 22" - 5H.P. SNOW THROWER 536.884790

## WHEELS ASSEMBLY

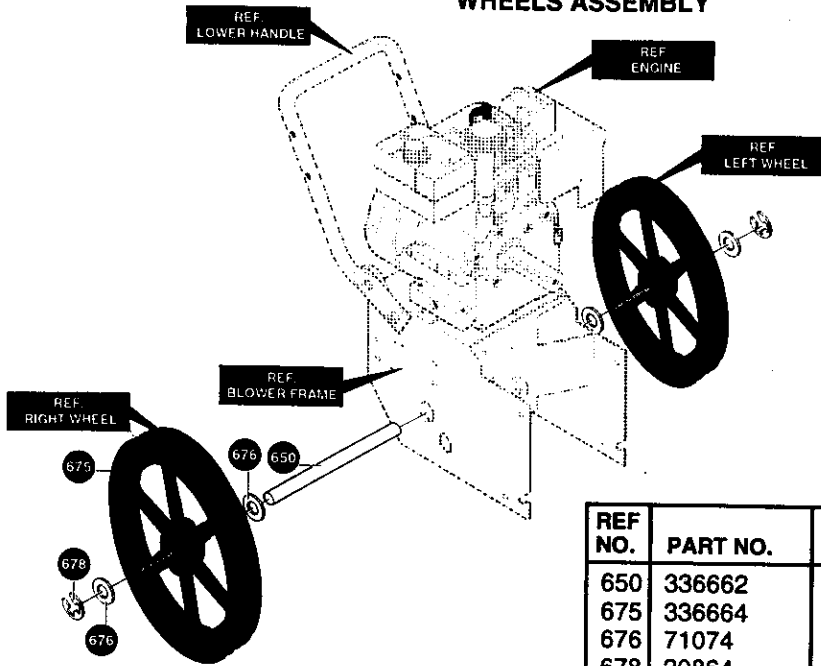

REF NO.	PART NO.	PART NAME
650	336662	Axle, .50x20"
675	336664	Tire & Rim
676	71074	Flatwasher, .53x1.00x.063
678	20864	Ring Retaining E

336637 B

## HANDLE ASSEMBLY

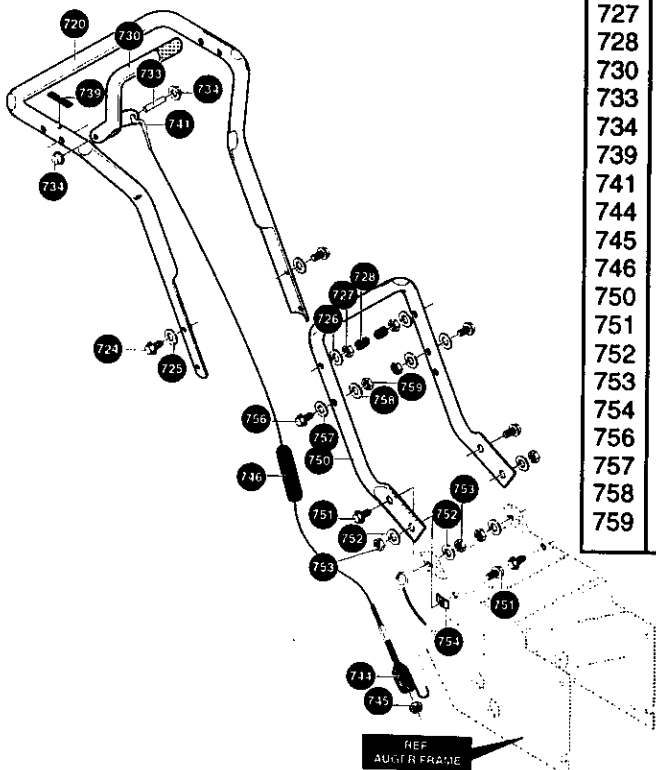

REF NO.	PART NO.	PART NAME
720	9552-853	Handle, Upper
724	11234	Screw, 5/16-18x2.75
725	120393	Flatwasher, .344x.69x.065
726	120638	Washer, .328x.60x.09
727	120376	Nut, 5/16-18
728	11261	Stop, Red Plastic
730	334195	Kit for Handle, Assy RH
733	4140	Pin, Clutch
734	3535	Nut, Push on Cap
739	4049	Bumper, Rect
741	1579	Cable, Clutch
744	1673	Spring, Auger Clutch
745	782585	Nut, 1/4-20 Reghexctrlk
746	308146	Boot, Clutch Spring
750	336667-853	Handle, Lower
751	180079	Screw, 5/16-18x1.00
752	120638	Washer, .328x.60x.09
753	120376	Nut, 5/16-18 Reghex
754	309436	Push nut
756	235	Screw, 5/16-18x2.00
757	120393	Flatwasher, .344x.69x.065
758	120638	Washer, .328x.60x.09
759	120376	Nut, 5/16-18 Reghex

336639E

**CRAFTSMAN 22" - 5H.P. SNOW THROWER 536.884790**  
**CHUTE CONTROL ROD ASSEMBLY**

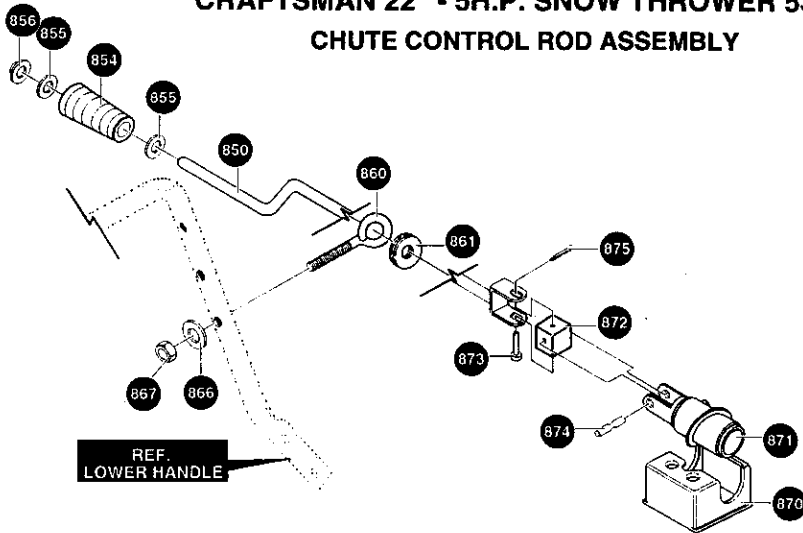

337666 B

REF NO.	PART NO.	PART NAME
850	585426	Crank, Assy w/Yoke
854	307399	Handle, Chute Crank
855	309312	Flatwasher, .39x.70x.05
856	578159	Ring, Ret E
860	336704	Bolt, Eye
861	148	Grommet, Eye Bolt
866	120394	Flatwasher, .406x.81x.065

REF NO.	PART NO.	PART NAME
867	71046	Nut, 3/8-16
870	585195	Bracket, Worm
871	585196	Worm, Gear Chute
872	578063	Block, Univ Piv
873	578309	Pin, Clevis
874	578060	Pin, Univ Joint
875	579493	Pin, Cotter

**DECALS**

↑ Symbol denotes top of decal application.

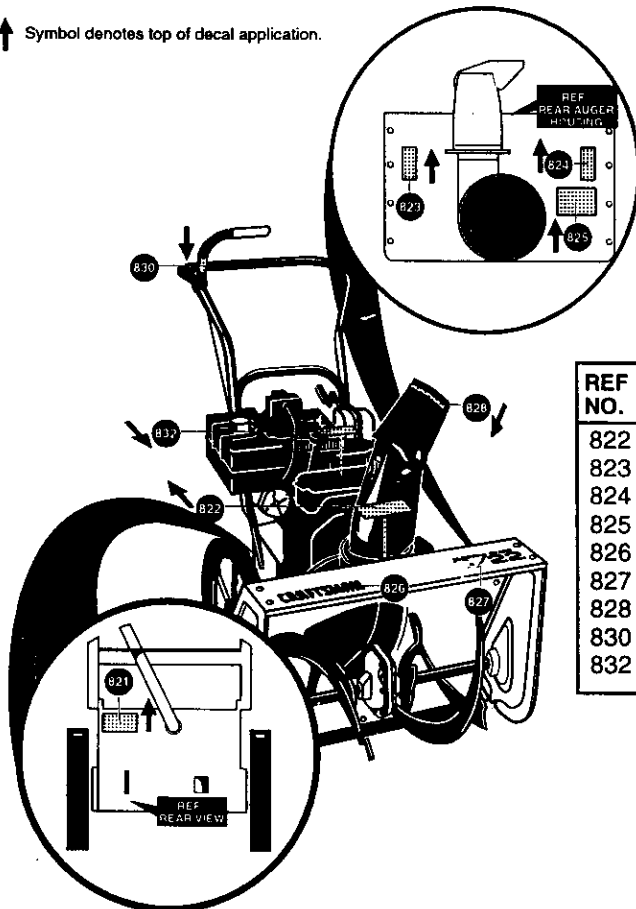

REF NO.	PART NO.	PART NAME
822	760971	Decal, 9" Impeller
823	313892	Decal, Danger Chute/Hand
824	70141	Decal, Danger Auger Foot
825	302922	Decal, Danger English
826	760972	Decal, Craftsman (RED)
827	760963	Decal, Electric Start
828	761079	Decal, Danger Chute
830	3903	Decal, Auger Drive Engage
832	760983	Decal, Toolbox into

336641 C

# CRAFTSMAN 4-CYCLE ENGINE MODEL NUMBER 143.985003

CARBURETOR 640084

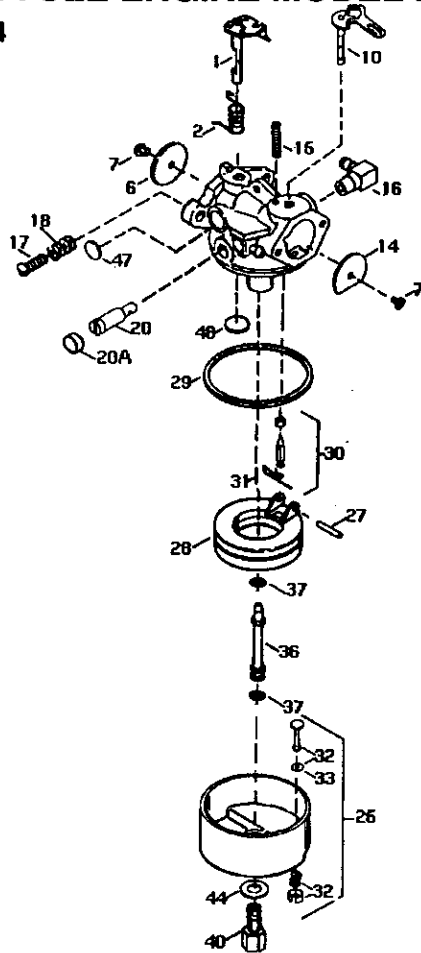

REF.	PART#	PART NAME
1	631615	THROTTLE SHAFT & LEVER ASSY.
2	631767	THROTTLE RETURN SPRING
6	640070	THROTTLE SHUTTER
7	650506	THROTTLE & CHOKE SHUTTER SCREW
10	632108	CHOKE SHAFT & LEVER ASSY
14	631815	CHOKE SHUTTER
15	630735	CHOKE POSITIONING SPRING
16	631807	FUEL FITTING
17	651025	THROTTLE CRACK SCREW/IDLE SPEED SCREW
18	630766	TENSION SPRING
20	640018	IDLE RESTRICTOR SCREW
20A	640053	IDLE RESTRICTOR SCREW CAP
25	631951	FLOAT BOWL ASSY (INCL. NOS. 32 & 33)
27	631024	SHAFT, FLOAT
28	632019	FLOAT
29	631028	"O" RING, FLOAT BOWL TO BODY
30	631021	INLET NEEDLE, SEAT & CLIP, (INCL. NO 31)
31	631022	SPRING CLIP
32	27136A	BOWL DRAIN ASSY
33	27554	DRAIN PLUNGER GASKET
36	632735	MAIN NOZZLE TUBE
37	632547	"O" RING, MAIN NOZZLE TUBE
40	640085	HIGH SPEED BOWL NUT
44	27110	BOWL NUT WASHER
47	630748	WELCH PLUG, IDLE MIXTURE WELL
48	631027	WELCH PLUG, ATMOSPHERIC VENT

# CRAFTSMAN 4-CYCLE ENGINE MODEL NUMBER 143.985003

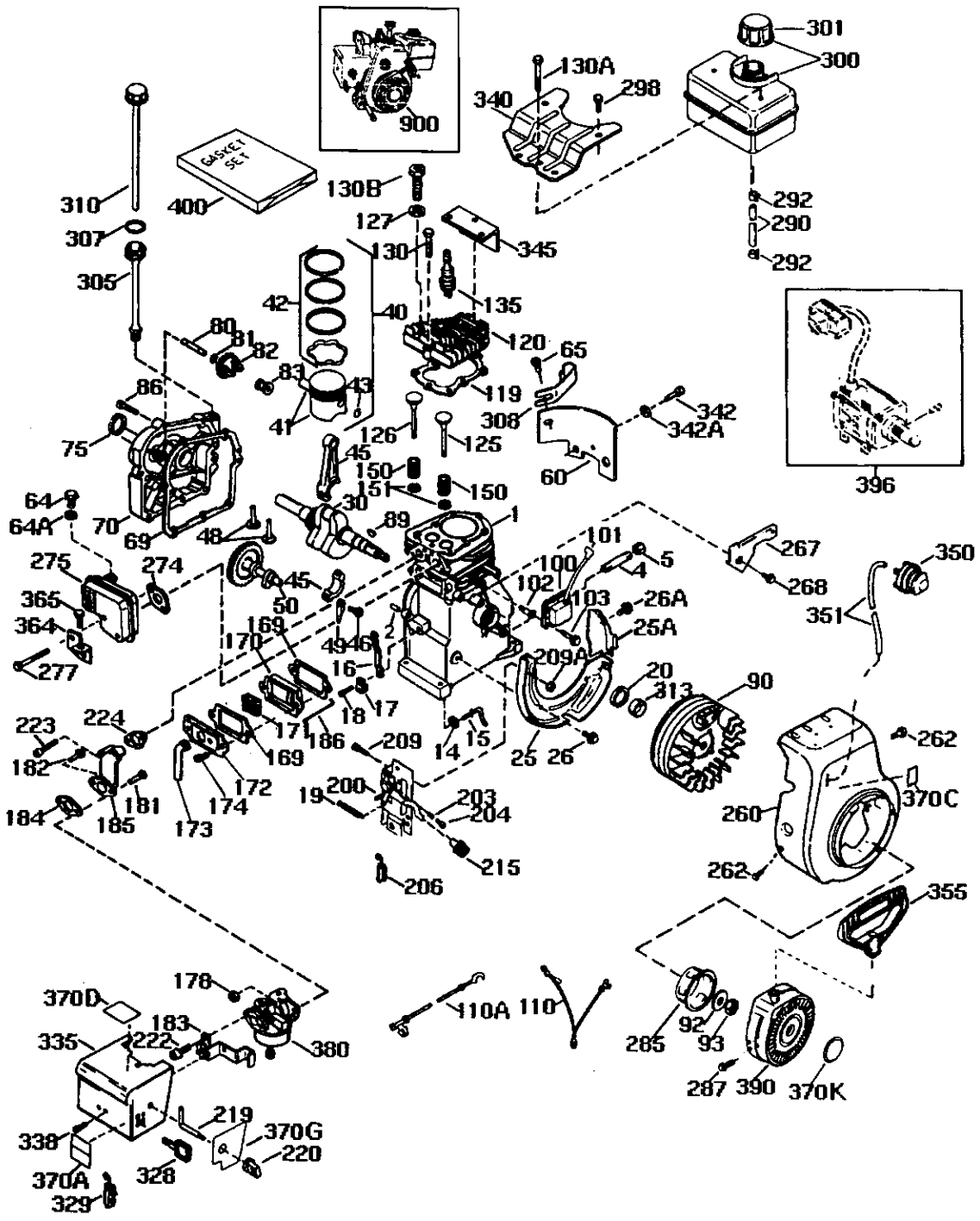

## CRAFTSMAN 4-CYCLE ENGINE MODEL NUMBER 143.985003

REF.	PART#	PART NAME	REF.	PART#	PART NAME
1	36469A	CYLINDER (INCL. 2,20,72&125)	130A	650694A	SCREW, 5/16-18X2"
2	26727	DOWEL PIN	130B	650818	SCREW, 5/16-18X1-1/2"
4	0	OIL DRAIN EXTENSION (PURCHASE LOCALLY)	135	35395	RESISTOR SPARK PLUG (RJ19LM)
5	30969	EXTENSION CAP	150	31672	VALVE SPRING
14	28277	WASHER	151	31673	VALVE SPRING CAP
15	31334	GOVERNOR ROD	169	27234A	VALVE COVER GASKET
16	31510	GOVERNOR LEVER	170	27666	BREATHER BODY
17	31335	GOVERNOR LEVER CLAMP	171	31410	BREATHER ELEMENT
18	651018	SCREW, TORX T-15, 8-32X19/64"	172	34146	VALVE COVER
19	31426	EXTENSION SPRING	173	35350	BREATHER TUBE
20	32600	OIL SEAL	174	650783	SCREW, 10-24X3/4"
25	36552	BLOWER HSING BAFFLE (INCL 262)	178	29752	NUT & LOCK WASHER 1/4-28"
25A	35883	BAFFLE EXTENSION	181	650870	SCREW, 1/4-28X1-11/16"
26	650802	SCREW, 1/4-20X5/8"	182	6201	SCREW, 1/4-28X7/8"
26A	650926	SCREW 8-32X21/64"	183	34583A	CHOKE BRACKET
30	34740	CRANKSHAFT	184	26756	CARBURETOR TO INTAKE PIPE GASKET
40	36073	PISTON, PIN & RING SET (STD)	185	33691	INTAKE PIPE
40	36074	PISTON, PIN & RING SET (.010" OS)	186	32698	GOVERNOR LINK
40	36075	PISTON, PIN & RING SET (.020" OS)	200	36677	CONTROL BKT (INCL 203-209A)
41	36070	PISTON & PIN ASSY (STD) (INCL. 43)	203	31342	COMPRESSION SPRING
41	36071	PISTON & PIN ASSY (.010 OS) (INCL. 43)	204	651029	SCREW, TORX T-10 5-40X7/16"
41	36072	PISTON & PIN ASSY (.020 OS) (INCL. 43)	206	610973	TERMINAL
42	36076	RING SET (STD)	209	650139	SCREW, 8-32X3/4"
42	36077	RING SET (.010" OS)	209A	30322	LOCK NUT, 8-32
42	36078	RING SET (.020" OS)	215	35440	CONTROL KNOB
43	20381	PISTON PIN RETAINING SET	219	34582	CHOKE ROD
45	32875A	CONNECTING ROD ASSY (INCL 46 & 49)	220	35438	CHOKE KNOB
46	32610A	CONNECTING ROD BOLT	222	28820	SCREW 10-32X1/2"
48	27241	VALVE LIFTER	223	650664	SCREW, 1/4-20X1-19/32"
49	32654	OIL DIPPER	224	33673A	INTAKE PIPE GASKET
50	33158	CAMSHAFT (BCR)	260	35656A	BLOWER HOUSING
60	29745	BLOWER HOUSING EXT.	262	650737	SCREW, 1/4-20X1-19/32"
64	30063	SCREW, TORX T-30 1/4-20X1/2"	267	34212	HOLD DOWN BRACKET
64A	8345	WASHER	268	30200	SCREW, 10-24X9/16"
65	650238	SCREW, 10-24X1/2"	274	33670A	EXHAUST GASKET
69	27677A	CYLINDER COVER GASKET	275	35771	MUFFLER (INCL 274)
70	34674C	CYLINDER COVER (INCL. 75 -83)	277	650327	SCREW 1/4-20X2-27/64"
75	27897	OIL SEAL	285	36467A	STARTER CUP
80	30574A	GOVERNOR SHAFT	287	650926	SCREW 8-32X21/64"
81	30590A	WASHER	290	30705	FUEL LINE
82	30591	GOVERNOR GEAR ASSY. (INCL. 81)	292	26460	FUEL LINE CLAMP
83	30588A	GOVERNOR SPOOL	298	650665	SCREW, 1/4-15X3/4"
86	650488	SCREW, 1/4-20X1-1/4"	300	35584	FUEL TANK(INCL 292&301)
89	610961	FLYWHEEL KEY	301	35355	FUEL CAP
90	611199	FLYWHEEL(W/RING GEAR)	305	35554	OIL FILL TUBE
92	650815	BELLEVILLE WASHER	307	35499	"O" RING
93	650816	FLYWHEEL NUT	308	35539	FILL TUBE CLIP
100	34443B	SOLID STATE IGNITION	310	35556	DIPSTICK
101	610118	SPARK PLUG COVER	313	34080	SPACER
102	651024	SOLID STATE MTNG STUD	328	35593	IGNITION KEY
103	651007	SCREW, TORX T-15, 10-24X15/16"	329	610973	TERMINAL
110	35182	GROUND WIRE	335	35072	CARBURETOR COVER
110A	36874	GROUND WIRE	338	650257	SCREW 8-32X5/16"
119	36443	CYLINDER HEAD GASKET	340	36247	FUEL TANK BRACKET
120	36441	CYLINDER HEAD(INCL. 131)	342	39963	SCREW TORX T-30 1/4-20X1/2"
125	36471	EXHAUST VALVE (STD) (INCL. 151)	342A	650675	WASHER
125	36472	EXHAUST VALVE (1/32" OS) (INCL 151)	345	33344	HEAT BAFFLE
126	32644A	INTAKE VALVE (STD) (INCL 151)	350	570682	PRIMER ASSY.
126	32645A	INTAKE VALVE (1/32" OS) (INCL 151)	351	32180C	PRIMER LINE
127	650691	WASHER	355	590574	START HANDLE(MITTEN GRIP)
130	6021A	SCREW, 5/16-18X1-1/2"	364	33333	CARBURETOR COVER BKT
			365	650735	SCREW 10-24X3/8"
			370A	36261	LUBRICATION DECAL
			370C	36501	PRIMER DECAL
			370D	35878	WARNING DECAL
			370G	35282	CHOKE DECAL
			370K	36695	STARTER DECAL
			380	640084	CARBURETOR (INCL 184)
			390	590742	REWIND STARTER
			396	33290E	ELECTRIC STARTER MOTOR
			400	36444	GASKET SET



**STARTER NO. 590742**

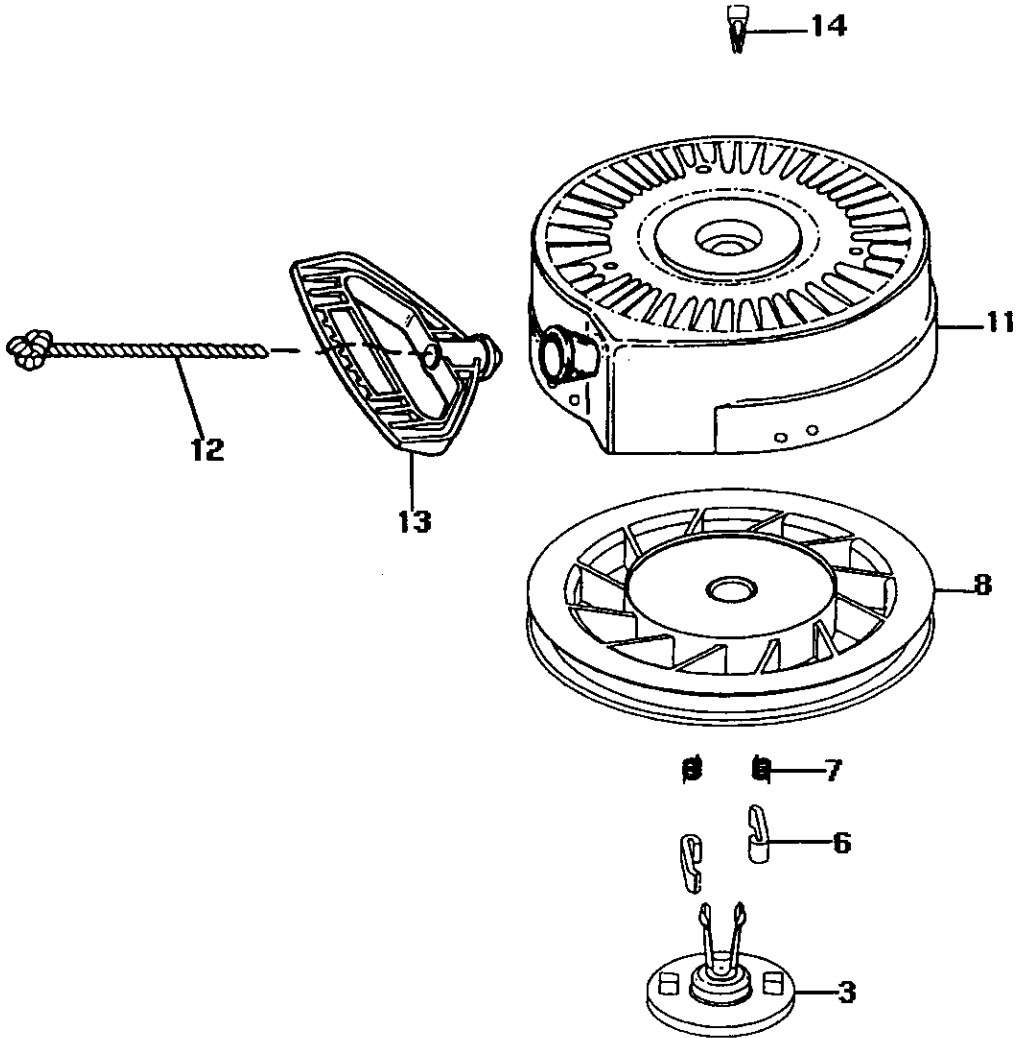

REF.	PART#	PART NAME
	590742	STARTER, REWIND
3	590740	RETAINER
6	590616	DOG, STARTER
7	590617	SPRING, DOG
8	590645A	PULLEY & REWIND SPRING ASSY
11	590647	HOUSING ASSY, STARTER
12	590535	ROPE, STARTER (LENGTH 98" & 9/64" DIA.)
13	590574	HANDLE, STARTER
14	590741	LOCKING TAB

**CRAFTSMAN 4-CYCLE ENGINE MODEL NUMBER 143.985003**  
**STARTER NO. 33290E**

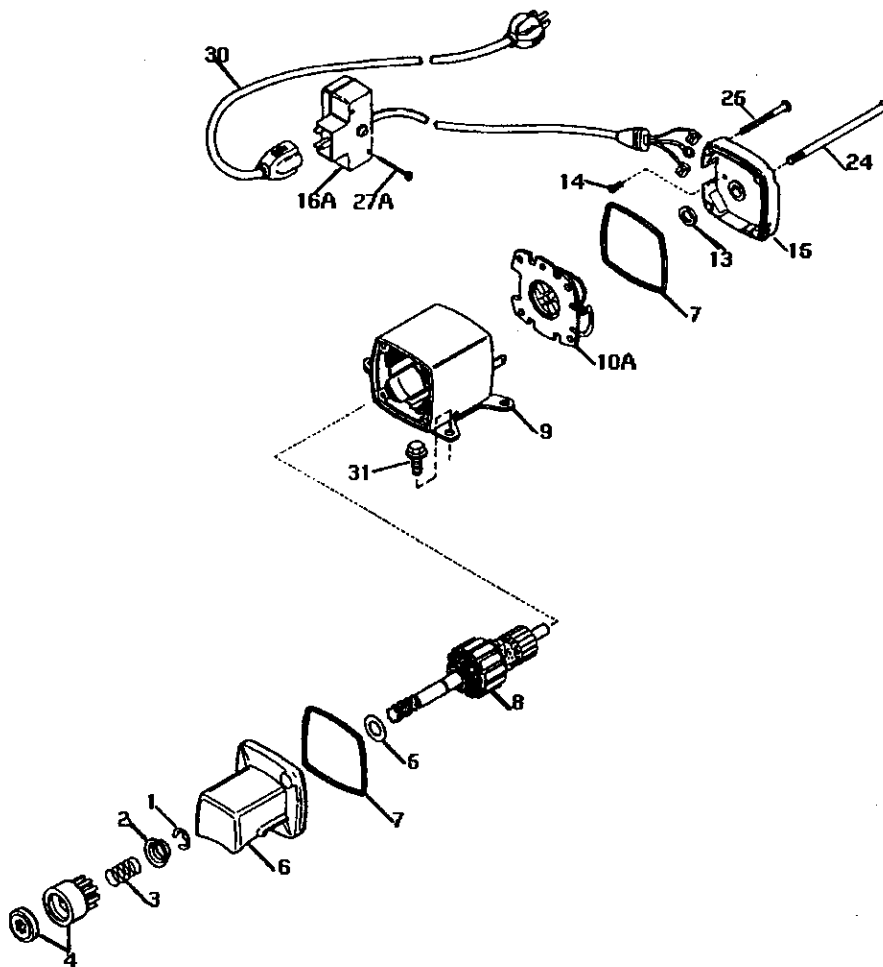

REF.	PART#	PART NAME
0	33290E	ELECTRIC STARTER (110 VOLT)
1	31749	RETAINER RING
2	33522	SPRING RETAINER
3	33769	ANTI-DRIFT SPRING
4	33524	NUT & GEAR
5	35911	THRUST WASHER
6	35461	DRIVE END CAP ASSY (INCL. 7)
7	35450	"O" RING
8	35912	ARMATURE
9	0	HOUSING ASSY (MUST PURCHASE COMPLETE MOTOR)
10A	35452A	BRUSH & SPRING CARD ASSY.
13	590500	THRUST WASHER
14	33441	GROUND SCREW
15	35453	COMMUTATOR END CAP ASSY (INCL 7)
16A	35454	SWITCH ASSY. (INCL 27A)
24	35462	CASE BOLT
25	35456	GROUNDING SCREW
27A	650819	SCREW 6-32X2-1/2"
30	32450B	EXTENSION CORD (10'6")
31	650759	SCREW, TORX-30, 1/4-20X23/32"

**REPAIR SERVICES**

*America's Repair Specialists*

