

E-BIKE

USER'S MANUAL

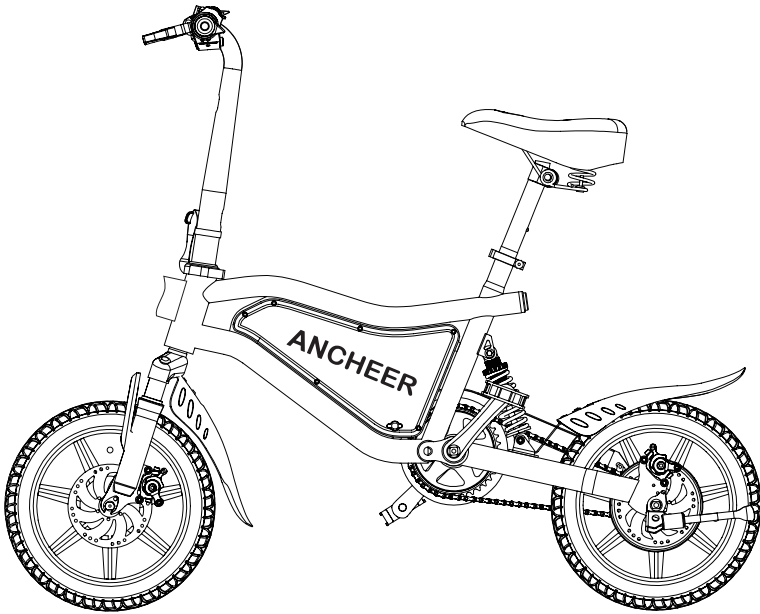

Caution read the manual before using your equipment



CONTENTS

IMPORTANT SAFETY INSTRUCTION	01
GENERAL INFORMATION	03
BIKE USAGE	07
INSTALLATION AND ADJUSTMENT	08
METER OPERATION	11
BATTERY AND CHARGING	17
MAINTENANCE	21
WARRANTY	22
ATTACHMENT	23
WARNING	25



IMPORTANT SAFETY INSTRUCTION

WARNING

WHEN USING THIS PRODUCT BASIC PRECAUTIONS SHOULD ALWAYS BE FOLLOWED, INCLUDING THE FOLLOWING:

THINGS TO KNOW BEFORE USE

- Read all the instructions before using the product.
- To reduce the risk of injury, close supervision is necessary when the product is used near children.
- Do not use this product if the flexible power cord or output cable is frayed, has broken insulation, or any other signs of damage.
- Do not put your fingers, hands or feet into the rotating wheel.
- Don't lend this product to people who can't operate it, so as not to cause harm; if you lend the bike, please let the user follow instructions, it could help to decrease the risk of accident.
- The E-bike cannot be used as off-road vehicles or used for extreme bicycle sports; when riding the bicycle, please wear a safety helmet and protective gear. It is forbidden to ride with one hand.
- Please abide by the traffic rules and prohibit riding on motorized lanes and roads with multiple pedestrians.
- Carry people or objects in accordance with the requirements of laws and regulations, and do not park in the building's lobby, evacuation stairs, walkways, and safe entrances and exits.
- It is recommended to charge and park in an outdoor dedicated parking hall, while avoiding rain; when charging, keep away from combustibles, and the charging time should not be too long.
- For safety reasons, please do not change the default speed setting of the electric bicycle and do not exceed speed limit in accordance with the traffic rule. Riding on non-motorized lanes, downhills and paved roads not exceeding 15km/h.

IMPORTANT SAFETY INSTRUCTION

WARNING

- When adjusting the handlebar or saddle, please be careful not to exceed the safety line markings on the handlebar and saddle.
- When using the motor, please be careful not to hit vigorously and keep the rotating shaft lubricated.
- Try to avoid riding in severe weather such as heavy rain and snow.
- It is not allowed to exceed the maximum load of the vehicle body when riding (the maximum load is 120KG).
- It is suitable for people of 16+ years old and physically fit adults, and it is strictly forbidden to drive electric bicycles on the road by people under 16 years old.
- Slow down when riding in rain or snow since the braking distance will be increased in such slippery conditions.

GENERAL INFORMATION

1. ABOUT ANCHEER ELECTRIC BIKE

ANCHEER electric bike is a leading icon of e-bikes. For years, ANCHEER has been not only dedicating to innovation, cutting-edge technology and premium materials, but also providing cost effective e-bikes, to satisfy riders' various needs of transportation and even desire of exploring sports & outdoors life. Just ride freely with ANCHEER !

2. WHAT'S IN THE BOX (PARTS LIST)

Description	Quantity
ANCHEER Electric Bike	1
User Manual	1
Charging Adapter	1
Pedal	2
Saddle	1
Tools Kit	1
Kickstand	1
Reflector	2
Bell	1

GENERAL INFORMATION

3. BIKE COMPONENTS

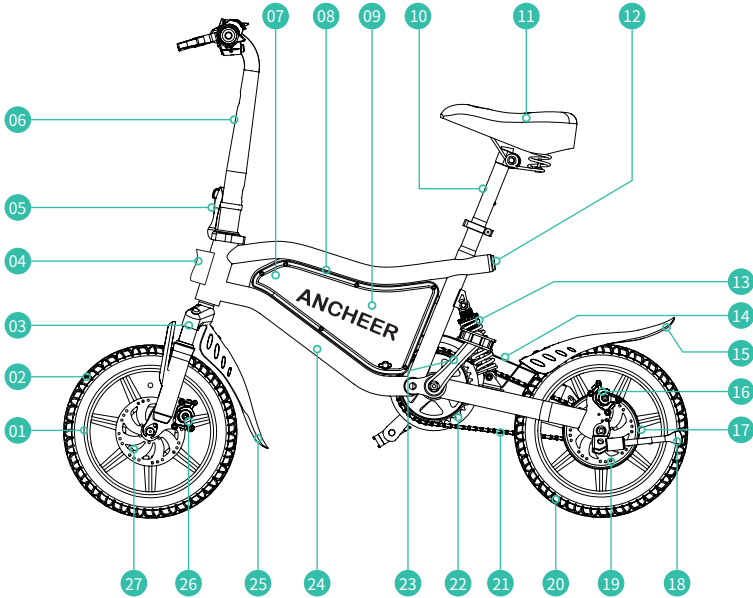

NO.	PART	NO.	PART	NO.	PART
01	Wheel Rim	10	Seat Tube	19	Rear Disc Brake
02	Tyre	11	Saddle	20	Tyre
03	Front Fork	12	Tail Light	21	Chain
04	Front Light	13	Rear Suspension	22	Chain Wheel
05	Vertical Folding Clasp	14	Chain Cover	23	Crank
06	Stem	15	Rear Fender	24	Frame
07	Controller	16	Rear Disc Brake Caliper	25	Front Fender
08	Battery Box	17	Motor	26	Front Disc Brake Caliper
09	Battery	18	Kickstand	27	Front Disc Brake

GENERAL INFORMATION

3. BIKE COMPONENTS

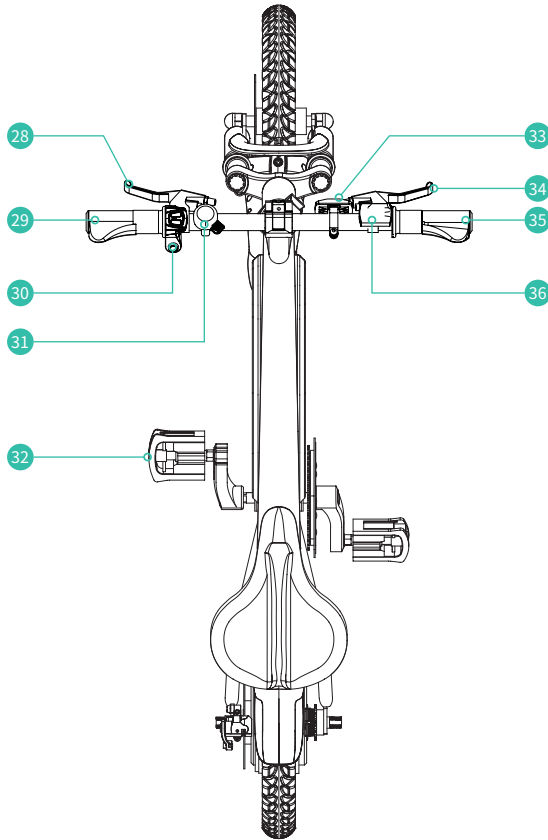

NO.	PART	NO.	PART	NO.	PART
28	Left Brake Lever	31	Bell	34	Left Brake Lever
29	Left Handlebar	32	Pedal	35	Throttle
30	Power Switch	33	Front Reflector	36	LED meter

GENERAL INFORMATION

4. TOOL LIST



0.20inch(5mm)
Allen Key

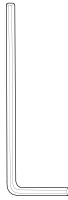

0.24inch(6mm)
Allen Key



Slotted-Phillips
Head Screwdriver



13-15mm Open
End Wrench

5. STANDOVER HEIGHT

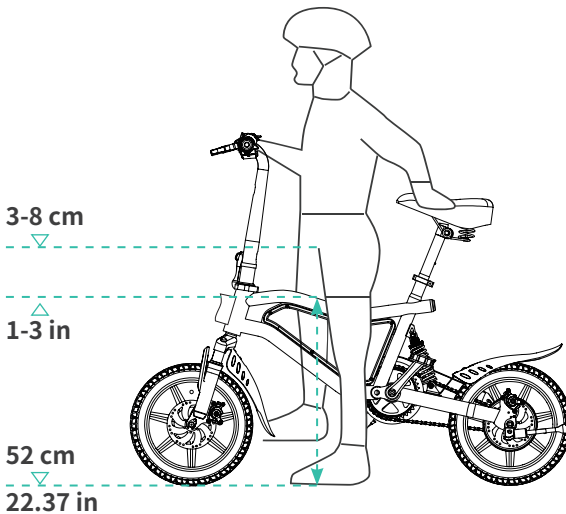

For the sake of safety and comfortable riding, when the rider stands on the ground there should be clearance of 59cm/23in from ground to the crotch of the rider. Also, at least 3-8cm/1-3in between the crotch and the top tube of the bike.

Note:

Standover height does not apply to bicycles with step-through frames. Instead, the limiting dimension is determined by saddle height range. You should adjust your saddle position without exceeding the limit line on the saddle tube.

BIKE USAGE

NOTICE

Before Riding

- Before riding the bike on the open road, try all the settings on the electric bike, and get used to various results in a safe and controllable environment.
- Please check the power circuit, lighting circuit, and test the brake system before cycling.
- Always check the tire pressure before starting to ride, and make sure that the tire is inflated to a pressure within the specified range.
 - 1 If the pressure is too low, the wheel may be damaged, or the inner tube may be squeezed, causing the tire to leak air.
 - 2 If the pressure exceeds the recommended maximum value, the tire may blow out of the rim, which may damage the bicycle and cause injury to the cyclist and nearby people.
- In order to ensure the safety of riding, please check regularly for loose parts or screws. The places that need to be checked include but not limited to the seat tube, wheels, handlebars and pedals.
- If necessary, please confirm whether the battery capacity can meet your riding demand.

During Riding

- Please wear helmets and riding gear that meet the requirements in accordance with regulations.
- Avoid traveling in severe weather such as heavy rain and snow, etc.
- Carry people or objects in accordance with the requirements of laws and regulations, and the load of the entire bike should not exceed 120kg.
- Obey the traffic rules.

After Riding

- After heavy use, do not touch the hot surface, such as the disc brake rotor or the side edge of the brake rim.
- When folding the kickstand, always make sure that the stand is secure and the base is firm to prevent the bicycle from falling.
- If the bicycle is splashed with moisture, please wipe it dry and clean in time.

INSTALLATION AND ADJUSTMENT

Open the package of the bike, take out the electric bike and all the parts inside and use the tool to cut off the packing rope. Please follow our YouTube channel- ANCHEER SPORT, we have provided installation tutorial.



Installation Video

1. Quick Start Unfolded Folding

Quick start unfolded folding, and adjust the handlebar angle.

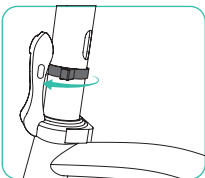
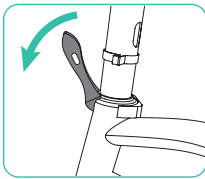
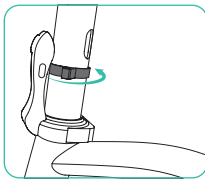

Must Be Fastened/Locked

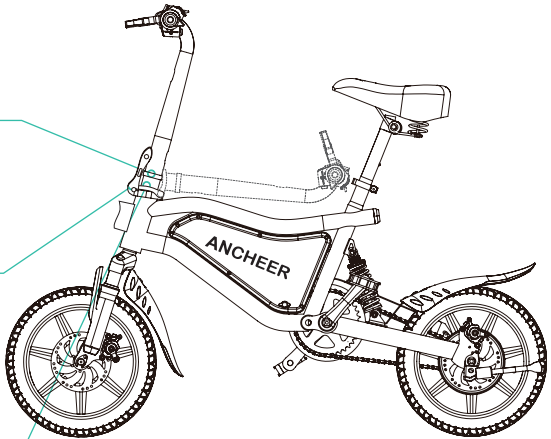

Note:

1. Unfold the stem.
2. Fold the vertical folding clasp.
3. Fasten the safety buckle.

INSTALLATION AND ADJUSTMENT

2. Mount The Pedals

Ensure that the thread of each pedal is fully inserted into the crank arm. Tighten the pedals completely with a wrench. (Counterclockwise screw the pedal marked "L" on the left side crank. Clockwise screw the pedal marked "R" on the right side crank.)

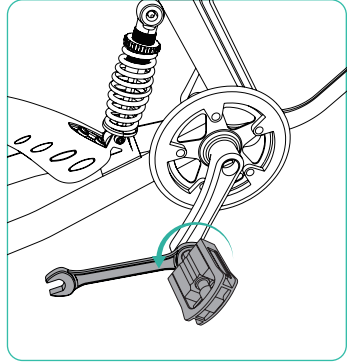
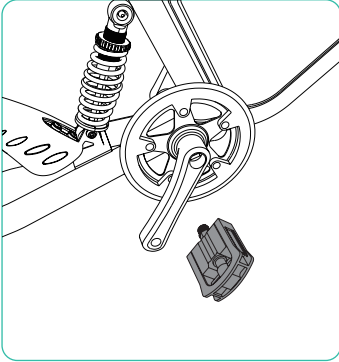

3. Install The Seat

3.1 Install the saddle tube into post receiver. Set right its position and adjust height to fit your riding habit. (Note: please be careful not to exceed the limit line) Tighten the fastening nut clockwise first, and then fasten the seat tube clamp.

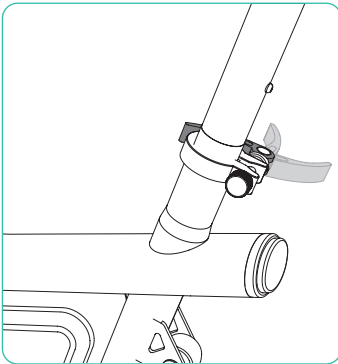

3.2 Adjust the seat angle to the most comfortable position.

INSTALLATION AND ADJUSTMENT

4. Brake Adjustment

Ensure that the brake cables are properly inserted into the brake levers before aligning a mechanical disc brake. If the disc rotor is bent or damaged, replace the rotor first.

- If the brake is not sensitive, loosen the anchor bolt of the brake cable to shorten the brake distance of the brake cable and then tighten the bolt. Or, lengthen the distance of the brake cable when the brake is too sensitive.

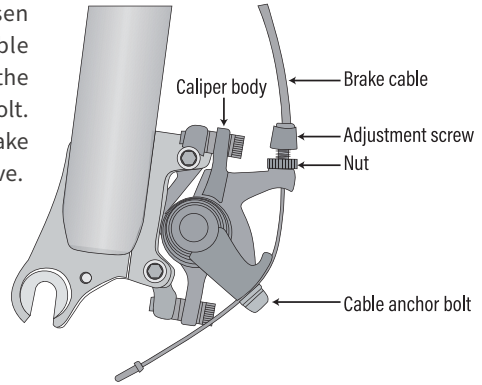

Leave the same clearance on both sides of the disc rotor

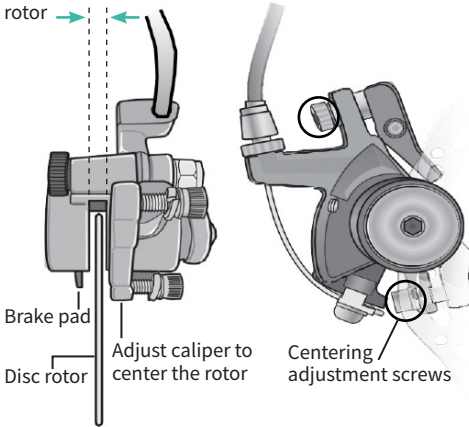

- If the rotor always rubs against the brake pad or the gap is too large, loose the two centering adjustment screws, but do not remove them. Slowly rotate the wheel and check the space between the rotor and the brake pad; adjust the position of the brake pad and the rotor. Centering the rotor and the pads to avoid friction. After the adjustment is complete, tighten the screws.

METER OPERATION

Activate The Battery

Before turning on the meter and using the lights, please turn on the switch button on the left handlebar to activate the battery. "ON" means open, and "OFF" means shut down.

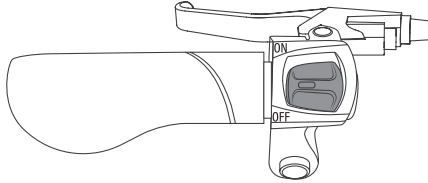

1. Product Name

Intelligent LCD display for e-bike.

2. Appearance And Dimensions

Intelligent LCD display for e-bike.



Fig. 2-1 Picture of Display

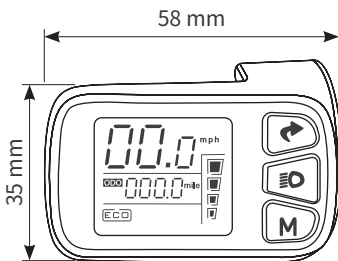

Fig. 2-2 Top View of Display Dimensions

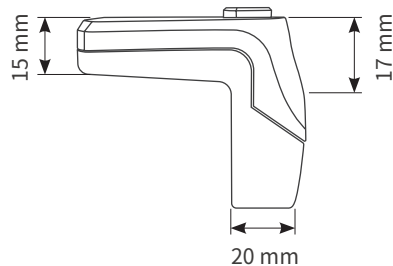





Fig. 2-3 Side View of Display Dimensions

METER OPERATION

3. Meter Function

3.1 Button Definitions

There are three buttons on the operating unit of display, the light button , plus button  and minus button .

3.2 Function Overview

Display provides a variety of functions to meet the riding needs of users, including:

- Battery level indicator
- Headlight indicator
- Speed indicator (including eco speed, med speed and High speed (Pure Electric))
- Mileage indicator (including total mileage(ODO) and trip distance (Trip))
- Parameter setting function

3.3 Functional Area Layout

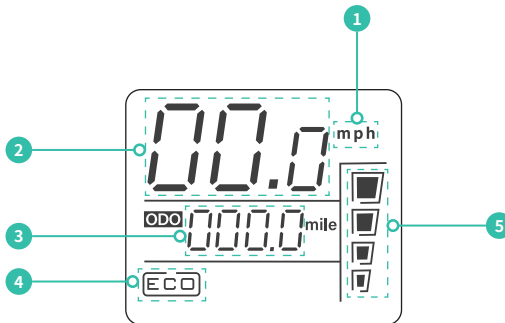

- 1 Speed unit -- Metric system: km, km/h; Imperial system: mile, mph
- 2 Speed Indicator — Speed unit Metric system: km/h; Imperial system: MPH
- 3 ODO/Trip distance indicator
- 4 Riding mode — Including eco speed, med speed and High speed (Pure Electric)
- 5 Battery level indicator

METER OPERATION

4. General Operation

4.1 Power On/Off

By switching the button "ON", the display will start to work and the working power supply of the controller will be turned on; switching it to "OFF", your e-bike will be powered off.

4.2 Display Interface

After the display is turned on, the display will show the real-time speed (mph) and the mileage (mile) by default.

4.3 Assist Level Selection

By pressing the button  , the e-bike assist level will be switched to change the motor output power. There are 3 assist levels(pure electric mode (throttle mode)) -- ECO, MID, HIGH.

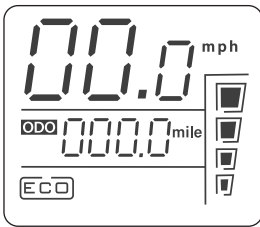

Eco Speed

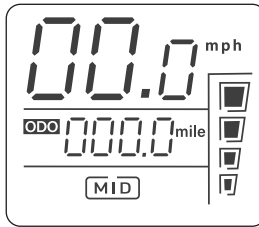

Middle Speed

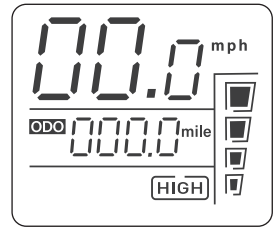

High Speed

Cruise mode:

When twisting and holding the throttle for 8 seconds, the "ECO/MID/HIGH" indicator flashes and it will enter the cruise state, then release the speed accelerator at this time, the electric bicycle will keep the current speed and continue to drive. After braking or twisting the throttle again, you can cancel the cruise state. Please pay attention to the road conditions and use cruiser mode carefully.

METER OPERATION

4.4 Battery level indicator

The battery level indicator consists of four segments. When the battery is fully charged, the four segments will be all on. In case of undervoltage, the last segment of the battery indicator light will flash, which means the battery has to be charged immediately.

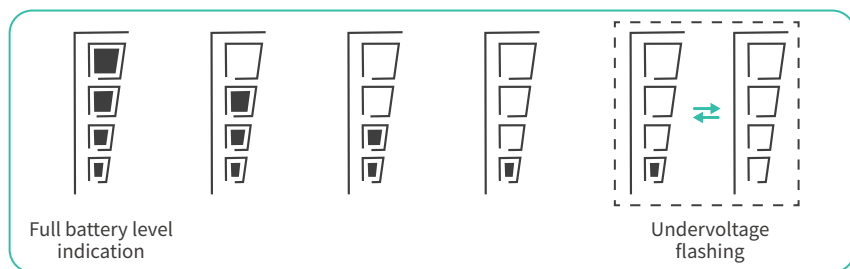

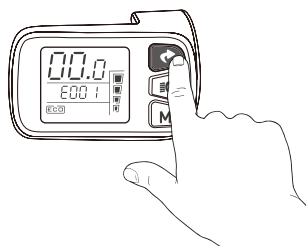
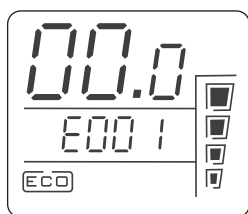

Fig.4-2 Battery level Switching Interface

4.5 Error code indicator

When a fault occurs in the electronic control system of your e-bike, the display will automatically indicate the error code: E001; then press the button  to display the corresponding error code in the mileage area in the format of E0*



Error codes			
Error codes	Definition	Error codes	Definition
E001	Communication Reception Abnormality	E006	Throttle Abnormality
E002	Meter Communication Transmission Abnormality	E007	Brake Abnormality
E003	Controller Abnormality	E008	Assist Sensor Abnormality
E004	Motor Hall Effect Sensor Abnormality	E009	Battery Undervoltage
E005	Motor Phase Loss		







METER OPERATION

5. Custom Setting

All parameters can only be set when your e-bike stops. The steps for custom setting are as follows:

Keep in the power-on state, and the display indicates the speed of 0.

5.1 Metric/imperial system setting

1. Press and hold the buttons  and  at the same time for more than 3 seconds to enter the selection interface of custom setting options. The display will indicate the code “P02” .
2. P02 refers to the metric/imperial system setting option. Press the button  /  to select the metric/imperial, then press the button  and  at the same time for more than 3 seconds to set and return to the general interface.

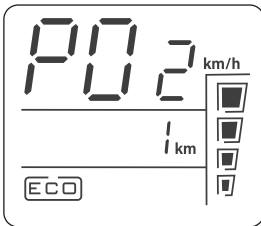

Metric system indicator interface

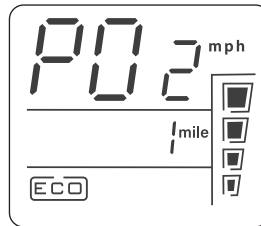







Imperial system indicator interface

Fig. 5-1 Metric/imperial System Setting Interface

METER OPERATION

5.2 Odometer reset

1. Press and hold the buttons  and  at the same time for more than 3 seconds to enter the selection interface of custom setting options, then press  for one time. The display will indicate the code "P26".
2. P26 refers to the odometer reset. Press  /  for more than 3 seconds to empty the mileage. Then press the button  and  at the same time for more than 3 seconds to return to the general interface.

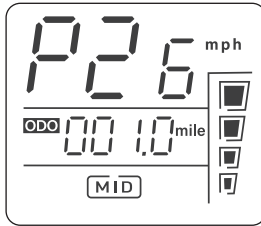

6. CAUTIONS

Please use safely, and do not plug or unplug the display when it is powered on.

- Please avoid bumping as far as possible.
- Please do not alter the background parameter settings of the display at will, otherwise normal riding cannot be guaranteed.
- If the display fails to work normally, it should be repaired as soon as possible.
- Due to product upgrades of the company, part of the displayed contents or functions of the product you bought may be different from the manual, depending on the actual model.

BATTERY AND CHARGING

Charging: Safe Operation Guide

- Please follow the instructions for use, otherwise the consequences are at his own risk. Please use the original special charger. It is strictly prohibited to use other chargers.
- Pay attention to the battery type and applicable voltage that the charger can charge, and it is strictly forbidden to mix them. The charging current shall not exceed 5A.

When Charging The Battery

- Insert the charger probe into the charger port on the e-bike battery. As shown in the figure.
- Insert the pronged end of the battery cord into the battery charger.
- Insert the AC plug into an AC outlet.
- The red indicator light turns on and will remain red until it is fully charged. The indicator light turns green once the battery is fully charged.

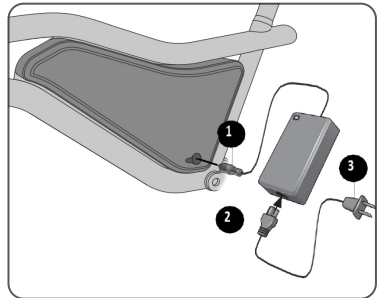

Safety Information

WARNING

Failure to observe the following warnings could result in electrical fires, explosion, severe burns or electrocution.

- Keep the battery dry, do not put the battery in acidic, alkaline liquid or combustibles, keep away from rain, fire and high temperature environment.
- It is strictly forbidden to connect the positive and negative poles of the battery reversely, and it is strictly forbidden to damage, disassemble or short-circuit the battery. Contact between the battery contacts and metal objects such as paper clips, coins, keys, nails, screws or other metal items could result in shorting out the battery and cause electrical fires, explosion, or severe burns.

BATTERY AND CHARGING

- Used batteries are hazardous chemicals, and the used batteries should not be disassembled without authorization, and recycled by relevant professional departments.
- It is forbidden to modify the battery, electronic control system and the frame structure of the bike, etc. Otherwise, it may cause safety hazards and void the warranty service. If you continue to do so, all will be at your own peril.
- Use the original battery.
- Do not replace it with other brand's or product's battery.
- The battery and battery charger contain hazardous materials. Always keep the battery and battery charger away from children, animals, or persons incapable of understanding the potential hazards.
- A damaged battery or battery charger (e.g. cable, plug or housing) may result in leakage of hazardous materials or be a potential source of sparking and fire. Always examine the battery and battery charger before each use. Never charge a damaged battery or use a damaged battery charger.
- Please use the original special charger. It is strictly prohibited to use other chargers. Charging the battery with an incompatible battery charger may result in electrical fires, explosion, severe burns or electrocution. Ensure the battery charger and the A/C outlet are the same voltage before charging the battery. Never use the battery charger to charge any other batteries.
- Pay attention to the battery type and applicable voltage that the charger can charge, and it is strictly forbidden to mix them.
- The charging time shall not exceed 12 hours, and the charging current shall not exceed 1.5A.
- Charging at 0°C~40° C/ 32 °F~104 °F, and discharging at -20 °C~45 °C/-4 °F~113 °F. Please do not store the battery in temperatures above 35 °C/ 95 °F or below -5 °C/ 23 °F.
- The battery and battery charger contain no serviceable parts. Do not open, disassemble, or modify the battery or charger.
- Improper handling of the battery and battery charger may result in electrical fires, explosion, severe burns or electrocution.
- Do not move the battery or battery charger during charging.
- Do not hold the battery charger during a thunder or lightning storm.
- Do not plug or unplug the battery charger with wet hands.

BATTERY AND CHARGING

- Do not place any items on the battery charger.
- When charging, it should be placed in a ventilated environment, and it is strictly forbidden to charge in a confined space, residential building or in a hot environment.
- The charger should not be carried with the ebike as much as possible. If it is really necessary to carry it, it should be placed in the toolbox after the shock absorption treatment is done. It is not allowed to disassemble or replace the components in the charger by yourself.
- It is recommended to charge the battery in the fireproof battery charging cover when charging. And the battery should be stored in the fireproof battery charging cover when not in use.
- When not in use for a long time, keep the battery in a cool and dry place, and charge the battery for two hours a month.

Reminder

Charge a new battery 4 hours before you use it in your product for the first time.

If the battery is dropped or damaged due to a bicycle accident, there may be a danger of electrolyte leakage. Please stop using it immediately.

It is better not to wait until the power is completely exhausted before charging, which can more effectively extend the battery life. Besides, Overheating or undercharging the battery may shorten battery life.

How far can a fully charged battery go?

It depends on the load weight, road conditions and battery capacity. But under the same conditions, the average speed can last longer riding distances. Using pedal assist mode allows you to go further.

It is recommended to charge the battery in the fireproof battery charging cover when charging. And the battery should be stored in the fireproof battery charging cover when not in use.

BATTERY AND CHARGING

Battery Disposal

- Battery must be recycled or disposed of in an environmentally sound manner.
- Do not dispose of the battery in a fire. The battery may explode or leak.
- Do not dispose of a battery in your regular household trash.



MAINTENANCE

- The front and rear wheels of the vehicle should be located in the center of the front fork or frame.
- After riding, please store the bike in a place without sunlight and rain.
- Water showering is forbidden, and the surface of the car body can be wiped with a semi-dry cloth.
- Do not touch the charging hole on the bicycle, or touch it with metal, otherwise, it may cause an accident due to an instantaneous short circuit of the current.
- Check all cables and cable housings for fraying, breaks, rust, or corrosion and replace if necessary.
- Check the motor and brake frequently, and do not fill the brake area with oil. Additionally, check the brake pads for any damage as they will be worn over time and eventually need replacement.
- Regularly check the various screws of the car and the places that need to be fastened, and regularly reinforce to prevent injury and unnecessary wear and tear on your e-bike.
- Recommended torque (unit: kgf.cm): the horizontal screw 60-80, the stem screw 175- 200, the seat cushion screw 175-250, the wheel screw 320-450.
- Regularly check the tension of the chain, which can be adjusted by the chain regulator.
- Always check the tire for scratches, cracks, or excessive wear. The inner tube and the valve should be perpendicular to the wheel hub and not crooked. Accidentally punctured, damaged or excessively worn inner and outer tires need to be replaced immediately, please seek professional technicians to repair or replace your tires.
- It is forbidden to modify key structural parts such as the frame, front fork, standpipe, and electrical function parts. If damaged, use the original parts to replace it. Otherwise, the guarantee service will not be provided. Any loss or damage caused by the modification shall be solely responsible.

WARRANTY

One-Year Limited Hardware Warranty

Your electric bike includes a One Year Limited Hardware Warranty. ANCHEER provides warranty service for the electric bikes. If there is a hardware defect and a valid claim is received during the warranty period, we will resend new parts within the scope permitted by law.

The Warranty covers product defects in materials and workmanship under normal use. This Warranty is limited to original purchasers and is not assignable or transferable.

The Warranty starts on the date of your purchase and lasts for one year (the "Warranty Period") and the Warranty Period is not extended if the product is repaired or replaced.

The Warranty does not cover any damage due to: improper use; failure to follow the product instructions or to perform any preventive maintenance; unauthorized repair; external causes such as accidents, abuse, or other actions or events beyond our reasonable control.

Accessories	Quality Problem	Warranty Period	Service Content
Motor	Motor will not be able to use	A year	Free delivery of parts
Accelerator	Natural conditions (such as impact force cannot be used except damage)	A year	Free delivery of parts
Controller	Failure occurs under normal use	A year	Free delivery of parts
Charger	Failure occurs under normal use	A year	Free delivery of parts
Lithium Battery	Can't charge discharge under normal use	A year	Free delivery of parts

Support Services

We provide lifetime customer support services. For any questions about the product, please contact customer service from where you brought the equipment. We will be happy to answer your questions.

You can also email us your inquiries at support@iancheer.com.

ATTACHMENT

Performance index	Project	Parameter
SIZE	Material	Iron
	Released Size	1315*530*1065 mm
	Wheel size	14 inches
	Package size	1300*225*675 mm
	Color	Black/ White
PERFORMANCE	Weight	22KG
	Max load	264.55lbs/120kg
	Uphill	15 degree
	Working Temperature	-4°F~113°F/-20°C~45°C
	Waterproof	IPX4
STANDARDS	Battery	7.8Ah
	Power	500W(max)
	Rated voltage	48V
	Charging voltage	54.6V
	Input voltage	AC100~240V
	BMS	Yes
	Charging time	4-5 H
FEATURES	Lights	Front & Rear Lights
	Cruise	Yes
	Brake	Front & Rear Disc Brake

ATTACHMENT

Remarks:

- The amount of battery remaining, load of the bike(weight of rider and cargo), tire pressure, road environment, chain and wheel axle lubrication, etc. will affect the maximum speed;
- Riding habits, temperature, load, tire pressure, road environment and other factors will affect the riding range.

WARNING

Operation General

- Only use the e-bike and the drive assist system for safe, recreational riding. Use of the e-bike for a purpose it was not intended for is dangerous and could result in property damage, serious injury or death. Always follow the instructions for intended use and limitations.

Personal Restrictions

- Use of this e-bike by persons (including children) with reduced physical, sensory or mental capabilities or persons lacking experience and knowledge in the use of the e-bike could result in serious injury or death. The owner of this e-bike must ensure this product is not used by people with the conditions described above. Always follow the rules, regulations and laws (including age limits) related to the use of an e-bike in its area of use.
- A child may not realize or understand the e-bike has moving parts and components (e.g. battery). Never allow children to play or come into contact with the e-bike or its parts. Always follow all rules, regulations and laws regarding age limits and operation in the e-bike area of use.
- Riding the e-bike through water could result in loss of control and damage to the drive assist system. Do not ride into, or attempt to ride through, water or sub-merge any part of the e-bike.
- Riding with the kickstand in the down position may result in unexpected contact with the ground or other objects causing loss of control. Always ensure the kickstand is in the up position and securely locked in place before riding the e-bike.
- Sitting on the e-bike with the kickstand down may result in the e-bike tipping over. Never sit on the e-bike when it is only supported and stabilized by the kickstand. The kickstand is not designed to support the weight of a person.
- Overloading a rear basket could create dangerous riding conditions. Always observe the maximum weight limit. Never overload the rear basket.
- An improperly secured load on a rear rack could create dangerous riding conditions. Always ensure the load on the rear rack is properly secured before riding.

WARNING

- Never move the shifter while pedaling backward, nor pedal backwards immediately after having moved the shifter. This could jam the chain and cause serious damage to the bicycle.
- Like any mechanical device, a bicycle and its components are subject to wear and stress. Different materials and mechanisms wear or fatigue from stress at different rates and have different life cycles. If a component's life cycle is exceeded, the component can suddenly and catastrophically fail, causing serious injury or death to the rider.
- Scratches, cracks, fraying and discoloration are signs of stress caused fatigue and indicate that a part is at the end of its useful life and needs to be replaced. Product life is often related to the kind of riding you do and to the treatment to which you submit the bicycle. The bicycle's warranty is not meant to suggest that the bicycle cannot be broken or will last forever. It only means that the bicycle is covered subject to the terms of the warranty.
- Frequent inspection of your bike is important to your safety. Periodic, more detailed inspection of your bicycle is important. How often this more detailed inspection is needed depends upon you. You, the rider/owner, have control and knowledge of how often you use your bike, how hard you use it and where you use it. The materials used to make your bike determine how and how frequently to inspect. Ignoring this WARNING can lead to frame, fork or other component failure, which can result in serious injury or death.

Operation Details:

- Correct tightening force on fasteners- nuts, bolts, screws- on your bicycle is important. Too little force, and the fastener may not hold securely. Too much force, and the fastener can strip threads, stretch, deform or break. Either way, incorrect tightening force can result in component failure, which can cause you to lose control and fall.
- Loose or damaged handlebar grips or extensions can cause you to lose control and fall. Unplugged handlebars or extensions can cut you and cause serious injury in an otherwise minor accident.

WARNING

- The area in which you ride may require specific safety devices. It is your responsibility to familiarize yourself with the laws of the area where you ride and to comply with all applicable laws, including properly equipping yourself and your bike as the law requires. Observe all local bicycle laws and regulations. Observe regulations about bicycle lighting, licensing of bicycles, riding on sidewalks, laws regulating bike path and trail use, helmet laws, child carrier laws, special bicycle traffic laws. It's your responsibility to know and obey the laws. Failure to wear a helmet when riding may result in serious injury or even death.
- Do not remove the front or rear reflectors or reflector brackets from your bicycle. They are an integral part of the bicycle's safety system. Removing the reflectors reduces your visibility to others using the roadway. Being struck by other vehicles may result in serious injury or death. The reflector brackets may protect you from a brake straddle cable catching on the tire in the event of brake cable failure. If a brake straddle cable catches on the tire, it can cause the wheel to stop suddenly, causing you to lose control and fall.
- Although many catalogs, advertisements and articles about bicycling depict riders engaged in extreme riding, this activity is extremely dangerous, increases your risk of injury or death, and increases the severity of any injury. Remember that the action depicted is being performed by professionals with many years of training and experience. Know your limits and always wear a helmet and other appropriate safety gear. Even with state-of-the-art protective safety gear, you could be seriously injured or killed when jumping, stunt riding, riding downhill at speed or in competition. Bicycles and bicycle parts have limitations with regard to strength and integrity, and this type of riding can exceed those limitations or dramatically reduce the length of their safe use.
- Failure to confirm compatibility, properly install, operate and maintain any component or accessory can result in serious injury or death. Exposed springs on the saddle of any bicycle fitted with a child seat can cause serious injury to the child. Changing the components on your bike with other than genuine replacement parts may compromise the safety of your bicycle and may void the warranty. Contact customer service before changing the components on your bike.
- If your seat post is not inserted in the seat tube, the seat post, binder or even frame may break, which could cause you to lose control and fall.

WARNING

- When making saddle angle adjustments with a single bolt saddle clamp, always check to make sure that the serrations on the mating surfaces of the clamp are not worn. Worn serrations on the clamp can allow the saddle to move, causing you to lose control and fall. Always tighten fasteners to the correct torque. Bolts that are too tight can stretch and deform. Bolts that are too loose can move and fatigue. Either mistake can lead to a sudden failure of the bolt, causing you to lose control and fall.
- An insufficiently tightened stem clamp bolt, handlebar clamp bolt or bar end extension clamping bolt may compromise steering action, which could cause you to lose control and fall. Place the front wheel of the bicycle between your legs and attempt to twist the handlebar/stem assembly. If you can twist the stem in relation to the front wheel, turn the handlebars in relation to the stem, or turn the bar end extensions in relation to the handlebar, the bolts are insufficiently tightened. Be aware that adding aerodynamic extensions to handlebars will change the steering and braking response of the bicycle.
- Bolt or bar end extension clamping bolt may compromise steering action, which could cause you to lose control and fall. Place the front wheel of the bicycle between your legs and attempt to twist the handlebar/stem assembly. If you can twist the stem in relation to the front wheel, turn the handlebars in relation to the stem, or turn the bar end extensions in relation to the handlebar, the bolts are insufficiently tightened. Be aware that adding aerodynamic extensions to handlebars will change the steering and braking response of the bicycle.
- **WARNING!** The shorter the brake lever reach, the more critical it is to have correctly adjusted brakes, so that full braking power can be applied within available brake lever travel. Brake lever travel insufficient to apply full braking power can result in loss of control, which may result in serious injury or death.
- All quick-release levers should be inspected before every ride to be sure they are fully closed and secure. Failure to properly close a quick-release lever can cause loss of control of the bicycle resulting in injury or death. Make sure the wheel is properly seated and the quick-release lever is properly closed.
- Disregarding or misunderstanding of the following safety warnings, the safety warnings in the manuals associated with the e-bike parts, and safety labels on the e-bike could result in serious injury or death.
- **WARNING!** The shorter the brake lever reach, the more critical it is to have correctly adjusted brakes, so that full braking power can be applied within available brake lever travel. Brake lever travel insufficient to apply full braking power can result in loss of control, which may result in serious injury or death.

WARNING

- All quick-release levers should be inspected before every ride to be sure they are fully closed and secure. Failure to properly close a quick-release lever can cause loss of control of the bicycle resulting in injury or death. Make sure the wheel is properly seated and the quick-release lever is properly closed.
- Disregarding or misunderstanding of the following safety warnings, the safety warnings in the manuals associated with the e-bike parts, and safety labels on the e-bike could result in serious injury or death.

Anyone assembling, using, maintaining, transporting or storing this e-bike must read, understand, and follow these safety warnings before performing any of the actions stated.

SAVE THESE INSTRUCTIONS.



E Bike

Input: DC 48V, 1.5A

Max Speed: 20 mph (32km/h)

Power: 500W(max)

Model: AMA005931

Shenzhen DYU Intelligent Mobility Technology Co.,Ltd

Made in China

 support@iancheer.com
ANCHEER Customer Service

 Tel: +1 626 688 9296
Monday-Friday
9:00-12:00 AM PST
14:00-18:00 PM PST



Customer Service