

levoit®

LTF-F461S-AUS

Windi Lift Pro Tower Fan



User Manual



Table of Contents

Package Contents	2
Specifications	2
Safety Information	3
Getting to Know Your Smart Tower Fan	7
Controls & Display	9
Getting Started	11
VeSync App Setup	12
Using Your Smart Tower Fan	13
VeSync App Functions	14
Care & Maintenance	15
User Servicing Instructions	16
Troubleshooting	17
VeSync App Troubleshooting	18
Limited Warranty Information	20
Customer Support	23

Specifications

Model	LTF-F461S-AUS
Power Supply	AC 120V, 60Hz
Rated Power	36W
Timer	2–12 hr
Max Speed	25 ft/s
Noise Level	28–48dB
Fuse	2.5 Amp, 125V (3.6 x 10 mm)
Dimensions	12.5 x 12.5 x 47 in / 32 x 32 x 119 cm
Weight	11.5 lb / 5.2 kg

Package Contents

- 1 × Tower Fan Body
- 2 × Bases
- 1 × Pole
- 1 × Screw Set
- 1 × Screwdriver
- 1 × Remote Control
- 1 × 3V CR2025 Battery (Pre-Installed)
- 1 × User Manual
- 1 × Quick Start Guide

READ AND SAVE THESE INSTRUCTIONS

Safety Information

To reduce the risk of fire, electric shock, or other injury, follow all instructions and safety guidelines.

GENERAL SAFETY

- **Only** use your tower fan as described in this manual.
- **Do not** use your tower fan outdoors.
- To protect against electric shock, **do not immerse the tower fan** cord, plug, or housing in water or spray with liquids.
- **Do not** place the tower fan in a window. Keep your tower fan away from water and wet or damp areas.
- Keep your tower fan away from open flames, heat sources, or other heating and cooking appliances.
- **Do not** use where combustible gases, vapors, metallic dust, aerosol (spray) products, or fumes from industrial oil are present.
- **Do not** place anything into any opening on the tower fan.
- **Do not** use with any openings blocked; keep free of dust, lint, hair, and anything that may reduce airflow.
- Avoid contact with moving fan parts.
- **Do not** hang or mount the tower fan on a wall or ceiling.
- **Only** use the tower fan on a dry and level surface.
- Close supervision is necessary when the tower fan is used by or near children.
- Children should be supervised to ensure that they **do not** play with the tower fan.
- Children should be supervised to ensure they **do not** insert fingers or objects into the vent openings.
- Children should not clean or perform maintenance on the tower fan without supervision.
- Keep the inside of the tower fan dry. To prevent moisture buildup, avoid placing in rooms with major temperature changes.
- Unplug the tower fan when not in use for an extended period of time.
- **Do not** use other items or third-party parts as replacement parts for this tower fan.
- **Do not** use your tower fan if it is damaged or not working correctly, or if the cord or plug is damaged. **Do not** try to repair it yourself. Contact **Customer Support** (see page 23).
- **Do not** operate any fan with a damaged cord or plug. Discard fan or return to an authorized service facility for examination and/or repair.
- **Do not** run cord under carpeting. **Do not** cover cord with throw rugs, runners, or similar coverings. **Do not** route cord under furniture or appliances. Arrange cord away from traffic area and where it will not be tripped over.
- **WARNING:** To reduce the risk of fire or electric shock, **do not** use this tower fan with any solid-state speed controls (such as a dimmer switch).
- This tower fan is not to be used by persons (including children) with reduced physical, sensory, or mental capacities, or lack of experience and knowledge, unless they have been given supervision or instruction concerning the use

Safety Information (cont.)

- of the appliance by a person responsible for their safety.
- Not for commercial or industrial use. Household use **only**.
- Ensure that the fan is switched off from the supply mains before removing the guard.
- **WARNING:** To Reduce The Risk Of Fire, Electric Shock Or Injury To Persons, Do Not Use Replacement Parts That Have Not Been Recommended By The Manufacturer (e.g. Parts Made At Home Using A 3D Printer).
- User instructions of portable and window mounted fans shall state that a fan shall not be modified by users, such as by adding supplemental filters to fans not intended to be used for air cleaning purposes.

POWER CORD & FUSE

- Your tower fan has a polarized plug (one prong is wider than the other), which fits into a polarized outlet **only** one way.
If the plug does not fit, reverse the plug. If it still does not fit, **do not** use the plug in that outlet. **Do not** alter the plugin any way.
- Turn off the tower fan before removing the plug from the outlet. To unplug, grab the plug and pull from the outlet. **Never** pull from the power cord.
- Keep the tower fan near the outlet it is plugged into. The use of an extension cord is not recommended.
- **Always** turn the tower fan off and unplug it when not in use and before moving, cleaning, or servicing the fan.
- **Never** place the cord near any heat source.
- **Do not** cover the cord with a rug, carpet, or other covering. **Do not** place the cord under furniture or appliances.
- To avoid a tripping hazard, keep the cord out of areas where people walk often. Place the cord where it will not be tripped over and safely coil the cord.
- A loose fit between the AC outlet and plug may cause overheating and a distortion of the plug. Contact a qualified electrician to replace a loose or worn outlet.
- This product employs overload protection (fuse). A blown fuse indicates an overload or short-circuit situation. If the fuse blows, unplug the product from the outlet. Replace the fuse as per the user servicing instructions (follow product marking for proper fuse rating) and check the product. To replace the fuse, see **Replacing the Fuse**, page 16. If the replacement fuse blows, a short-circuit may be present and the product should be discarded or returned to an authorized service facility for examination and/or repair. Please contact **Customer Support** (see page 23).
- If the power cord is damaged, it must be replaced by Vesync (US) Corporation or similarly qualified persons in order to avoid an electric or fire hazard. Please contact **Customer Support** (see page 23).
- Your tower fan should **only** be used with **120V, 60Hz** electrical systems. **Do not** plug into another type of outlet.

WARNINGS FOR USING THE REMOTE CONTROLLER



Warning: Contains coin battery



KEEP OUT OF REACH OF CHILDREN

WARNING

- **INGESTION HAZARD:** This product contains a button cell or coin battery.
- **DEATH** or serious injury can occur if ingested.
- A swallowed button cell or coin battery can cause **Internal Chemical Burns** in as little as **2 hours**.
- **KEEP** new and used batteries **OUT OF REACH** of **CHILDREN**.
- **Seek immediate medical attention** if a battery is suspected to be swallowed or inserted inside any part of the body.



- Remove and immediately recycle or dispose of used batteries according to local regulations and keep away from children. **DO NOT** dispose of batteries in household trash or incinerate;
- Even used batteries may cause severe injury or death;
- Call a local poison control center for treatment information;
- **Only** use with a 3V CR2025 battery;
- Non-rechargeable batteries are not to be recharged;
- **Do not** force discharge, recharge, disassemble, heat above manufacturer's specified temperature rating, or incinerate. Doing so may result in injury due to venting, leakage, or explosion resulting in chemical burns;
- Ensure the batteries are installed correctly according to polarity (+ and -);
- **Do not** mix old and new batteries, different brands or types of batteries, such as alkaline, carbon-zinc, or rechargeable batteries;
- Remove and immediately recycle or dispose of batteries from equipment not used for an extended period of time according to local regulations;
- **Always** completely secure the battery compartment. If the battery compartment does not close securely, stop using the product, remove the batteries, and keep them away from children.
- Place sticky tape around both sides of the battery and dispose of it immediately in an outdoor trashcan or recycle safely;
- Store spare batteries securely;
- Empty recycling units on a regular basis;
- Use non-transparent containers to keep the batteries out of view.

Unfortunately, it is not obvious when a button or coin battery is stuck in a child's esophagus (food pipe). The child might:

- Cough, gag, or drool a lot;
- Appear to have a stomach upset or a virus;
- Be sick;
- Point to their throat or stomach;
- Have pain in their abdomen, chest, or throat;
- Be tired or lethargic;
- Be quieter or more clingy than usual or otherwise "not themselves";
- Lose their appetite or have a reduced appetite;
- Not want to eat solid food / be unable to eat solid food.

These sorts of symptoms vary or fluctuate, with the pain increasing and then subsiding.

A specific symptom to button and coin battery ingestion is vomiting fresh (bright red) blood. If a child does this, seek immediate medical help.

The lack of clear symptoms is why it is important to be cautious with "flat" or spare button or coin batteries in the home and the products that contain them. Be aware that even used button or coin batteries may cause injury.

SAVE THESE INSTRUCTIONS

Getting to Know Your Smart Tower Fan

- A. Control Panel
- B. LED Display
- C. Vents

- D. Fan Blade
- E. Pole
- F. Base

- G. Release Button
- H. Adjustment Knob
- I. Remote Control

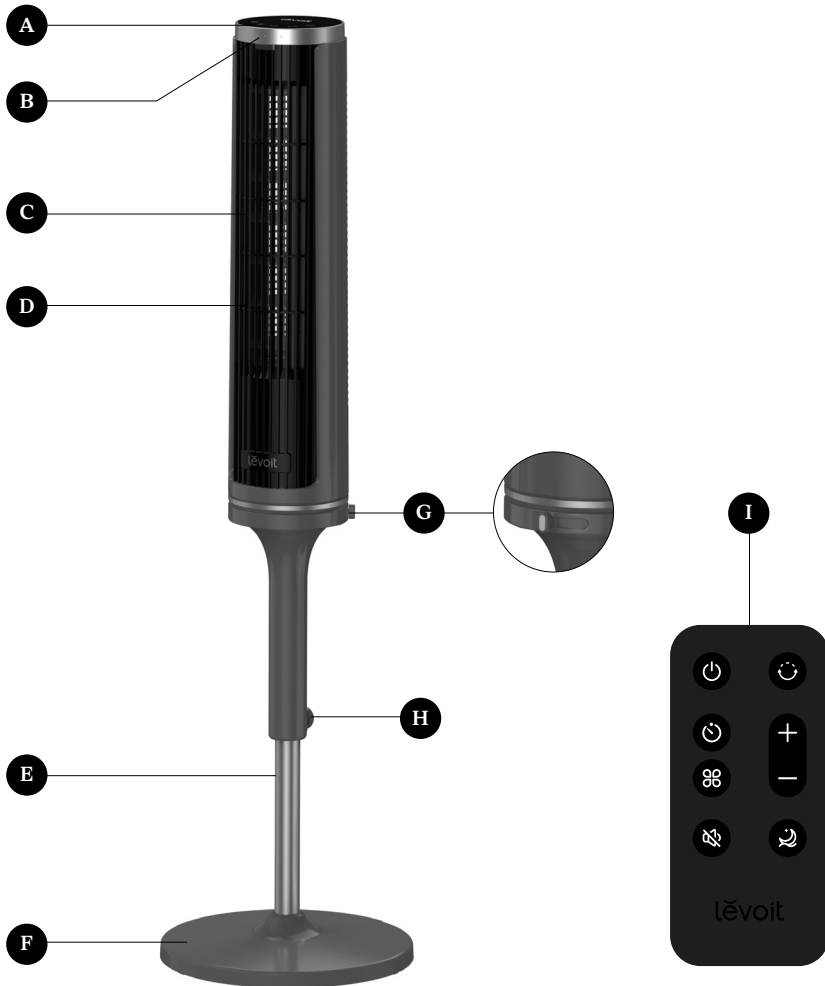

CONTROL PANEL

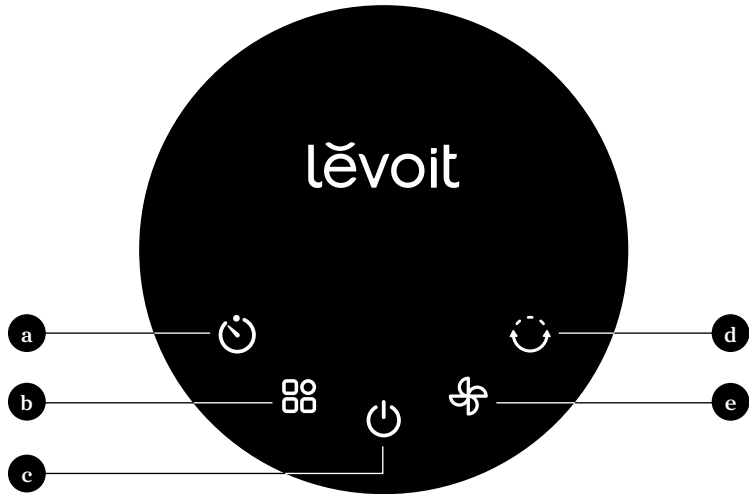

- a. Timer Button
- b. Fan Mode Button
- c. On/Off Button
- d. Oscillate Button
- e. Fan Speed Button

LED DISPLAY

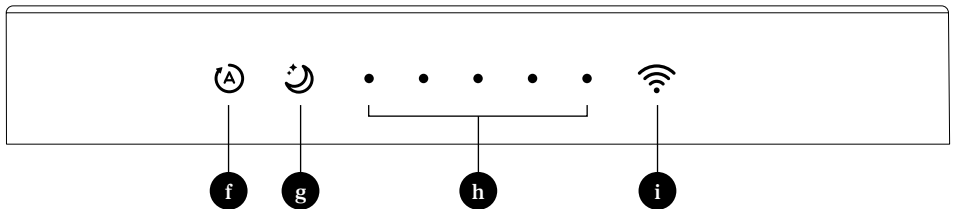

- f. Auto Mode Indicator
- g. Advanced Sleep Mode Indicator
- h. Fan Speed Indicators
- i. Wi-Fi Indicator

CONTROLS & DISPLAY



On/Off Button

- Tap to turn the tower fan on/off.
- Press and hold for 5 seconds to connect the tower fan to the VeSync app. See the in-app instructions for more information (see page 12).
- Press and hold for 15 seconds to reset the tower fan and disconnect from Wi-Fi (see page 12).



Fan Mode Button

- Tap to cycle through fan modes: Normal, Auto, and Advanced Sleep (see **Fan Modes**, page 13).
- Press and hold for 3 seconds to turn the selection sounds and display on/off (see **Sound & Display Off**, page 14).



Fan Speed Button

- Tap to cycle through fan speeds from 1 (low) to 5 (high).



Oscillate Button

- Tap to turn oscillation on/off.
- The tower fan has a 90° angle of oscillation.



Timer Button

- Tap to cycle through timer options: 2, 4, 6, 8, or 12 hours.

Indicator Lights

- Turns on to indicate fan speed and timer settings.

Indicator Lights	Fan Speed
● ○ ○ ○ ○	1
● ● ○ ○ ○	2
● ● ● ○ ○	3
● ● ● ● ○	4
● ● ● ● ●	5

Indicator Lights	Timer Indicator
● ○ ○ ○ ○	2 h
● ● ○ ○ ○	4 h
● ● ● ○ ○	6 h
● ● ● ● ○	8 h
● ● ● ● ●	12 h



Wi-Fi Indicator

- Blinks when connecting to the VeSync app, lights up when connected to VeSync, and is off when disconnected from it. See the in-app instructions for more information (see page 12).

REMOTE CONTROL

The remote control can be used to control any of the tower fan's functions from a distance. The remote must be within 16 ft / 5 m of the tower fan to work.

Note:

- Remove the plastic tab from the remote control's battery compartment before using.
- To replace the battery, see page 15



Sound & Display Off Button

- Press to turn selection sounds and display on/off (see **Sound & Display Off**, page 13).



Advanced Sleep Mode Button

- Press to turn Advanced Sleep Mode on/off (see **Advanced Sleep Mode**, page 13).

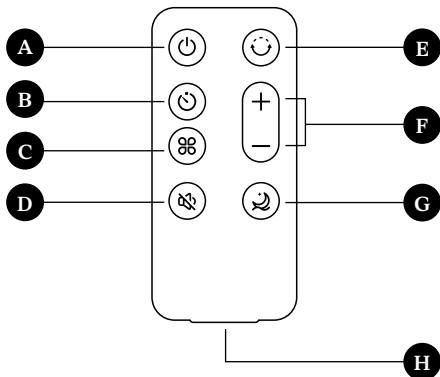

- A. On/Off Button
- B. Timer Button
- C. Fan Mode Button
- D. Sound & Display Off Button
- E. Oscillate Button
- F. Increase/Decrease Fan Speed
- G. Advanced Sleep Mode Button
- H. Battery Compartment (On the Bottom)

Getting Started

WARNING: Do not use the fan before finishing assembly.

1. Remove all packaging.
2. Snap the two pieces of the base together.

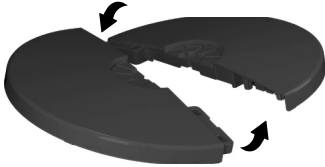

3. Attach the base to the pole with the provided screw set.
4. Place the tower fan body on the pole until it clicks into place.

Note 1: Please ensure that the pole is securely connected to the base.

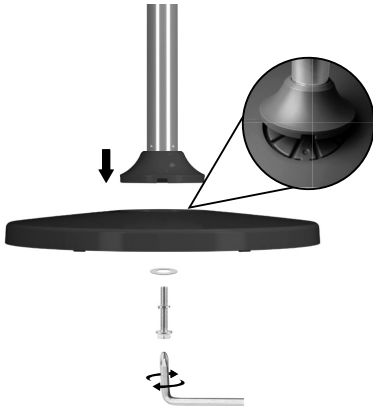

Note 2: Please ensure that the screw gaskets are placed at the bottom of the fan gaskets in the sequence shown in the diagram to enhance stability.

5. Place the tower fan on a flat, stable surface such as the floor.
6. When using the tower fan, allow at least 15 in / 38 cm of clearance from the front of the tower fan. Keep away from anything that would block air flow, such as curtains.

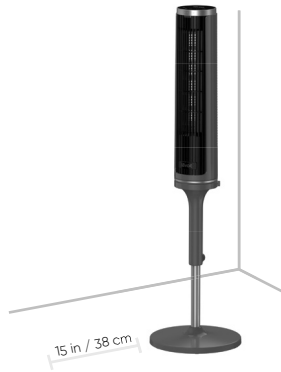

7. Optionally, for a shorter fan, you can use the tower fan body separate from the base.



VeSync App Setup

Note:

- The VeSync app is continually being improved and may change over time. If there are any differences, follow the in-app instructions.
- Requires device to run app, Wi-Fi or mobile data, and iOS® version 15 or Android™ version 8 (or above). Standard data and messaging rates may apply. Registration is required.

1. To download the VeSync app, scan the QR code or search “VeSync” in the Apple App Store® or Google Play Store.

Note: For Android™ users, choose “Allow” to use VeSync.

2. Open the VeSync app. If you already have an account, tap **Log In**. To create a new account, tap **Sign Up**.

Note: You must create your own VeSync account to use third-party services and products. These will not work with a guest account. With a VeSync account, you can also allow your family and friends to control your smart tower fan.



3. Follow the in-app instructions to set up your smart tower fan.

Note: Your phone must have Location turned on while your phone is connecting to your smart tower fan. This is required to establish the Bluetooth® connection. You can turn Location off after your smart tower fan is finished connecting to the VeSync app.

Connect With Amazon Alexa or Google Assistant™

You can use the VeSync app to connect your smart tower fan to Amazon Alexa or Google Assistant™. Follow the in-app instructions to connect VeSync to your voice assistant.





Note:

- You must create your own VeSync account to access voice assistants.
- A list of voice commands is available under settings in the VeSync app.

Wi-Fi Connection:

- To disconnect the Wi-Fi, press and hold  for 15 seconds until the Wi-Fi indicator turns off. This will restore the device's default settings and disconnect it from the VeSync app.
- To reconnect, please follow the instructions in the VeSync app for adding a device.

Using Your Smart Tower Fan

1. Plug in and tap  to turn on the tower fan. The fan will start on low.
2. Tap  to change fan speed from 1 (low) to 5 (high).
3. Tap  to cycle through different fan modes.
4. Tap  to turn on oscillation.
5. Tap  to set a timer.

Room Temperature	Fan Speed
< 73°F	1
73°–77°F	2
77°–80°F	3
80°–86°F	4
> 86°F	5

Figure 1.1

FAN MODES

Tap to cycle through fan modes: Normal, Auto, and Advanced Sleep.



Normal Fan Mode:

Use Normal Mode to manually control the tower fan's speed.

- Tap to change fan speed from 1 (low) to 5 (high).
- This is the tower fan's default mode.

Auto Mode:





Use Auto Mode for automatic fan speed adjustments according to the room temperature.

1. Tap  and select Auto Mode.  will show on the display.
2. The starting fan speed is determined by the current room temperature. *[Figure 1.1]*
3. Optionally, tap  to manually adjust the fan speed while in Auto Mode. The tower fan will then operate according to the following logic:
 - a. If the temperature increases 5°F, the fan speed will increase one level.
 - b. If the temperature decreases 5°F, the fan speed will decrease one level.

Note: The max ambient working temperature is 104°F.





Advanced Sleep Mode:

Advanced Sleep Mode is an optimized sleep mode that takes into account the stages before you sleep, during sleep, and as you wake up.

1. Tap  and select Advanced Sleep Mode, or press  on the remote.  will show on the display.
 - a. After 5 seconds, the display will turn off and selection sounds will be disabled.
 - b. The starting fan speed is determined by your current fan speed when you select Advanced Sleep Mode.
2. After 1 hour, the tower fan will decrease fan speed as the room temperature stabilizes.
3. The tower fan then automatically adjusts the fan speed according to the fluctuating room temperature as you sleep and wake up.
 - a. If the temperature increases 5°F, the fan speed will increase one level.
 - b. If the temperature decreases 5°F, the fan speed will decrease one level.
4. Tap , or  on the remote, to turn Advanced Sleep Mode off.

Using Your Smart Tower Fan (cont.)

SOUND & DISPLAY OFF

1. Press and hold  for 3 seconds to turn off selection sounds and the display.  will show on the display.
2. Optionally, press  on the remote control.
3. After **5 seconds of no operation**, the display will automatically turn off and selection sounds will be disabled.
4. Tap any button to temporarily turn the display back on. If you don't tap another button, the display will turn back off after 5 seconds.
5. Press and hold  for 3 seconds (or press  on the remote) to turn on selection sounds and the display.

MEMORY FUNCTION

When the tower fan is in standby or turned off and unplugged, it will remember all its previous settings, except for timer.

VeSync App Functions

The VeSync app allows you to access additional smart tower fan functions, including those listed below. As the app develops, more features may become available.

REMOTE CONTROL

- Change tower fan settings through the app.

TURBO MODE

- Use Turbo Mode to quickly circulate air in your home.
- The tower fan automatically starts oscillating and operates at fan speed 5.

ADVANCED SLEEP MODE

- Adjust settings to fit your sleep habits.

TIMER FUNCTION

- Set a timer between 1–24 hours.
- Easily view how much time is remaining.

SCHEDULES

- Create and customize tower fan schedules to fit your routines.

Note: *The VeSync app is continually being improved. The app's design, functions, content, etc. may change or be discontinued at any time without prior notice.*

Care & Maintenance

CLEANING THE TOWER FAN

- Unplug before cleaning.
- Wipe the outside of the tower fan with a soft, dry cloth. If necessary, wipe the housing with a damp cloth, then immediately dry.
- Use a vacuum, duster, or compressed air to clean the inside of the tower fan.
- If necessary, use a screwdriver to remove the back cover and clean the inside of the tower fan.



Note:

- *Make sure the tower fan is turned off before removing the back cover.*
- *Clean the internal parts with a dry cloth.*
- **Do not** clean with abrasive chemicals or flammable cleaning agents.

REPLACING THE REMOTE CONTROL BATTERY

1. Remove the battery compartment by pinching the tab and pulling the compartment out.

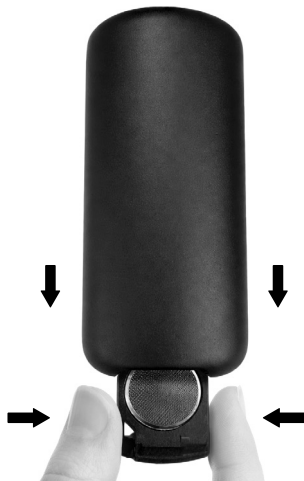

2. Remove the old battery.
3. Replace with a new 3V CR2025 battery. Make sure the polarities match.
4. Replace the battery compartment.

User Servicing Instructions

REPLACING THE FUSE

1. Unplug the tower fan. Grab the plug and pull from the outlet. **Never** pull from the power cord.
2. Open the fuse cover on the plug by sliding the fuse cover toward the metal prongs.

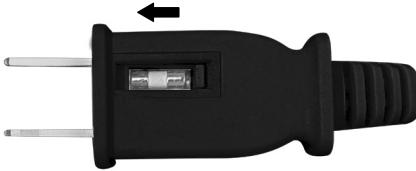

3. Carefully remove the blown fuse with tweezers or a small tool. Make sure not to break the glass fuse.
4. **RISK OF FIRE: Only** replace the fuse with a 2.5 Amp, 125V fuse (3.6 × 10 mm). **Do not** use any other type of fuse.
5. Slide the fuse cover closed.

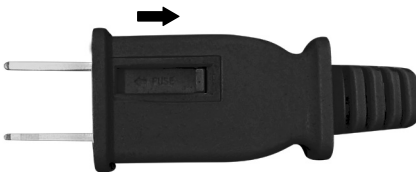

Note: If the replacement fuse blows, a short-circuit may be present. Please contact **Customer Support** (see page 23).

CAUTION, RISK OF FIRE: Do not replace the plug if it is damaged. If the plug is damaged in any way, stop using the tower fan and contact **Customer Support** (see page 23).

STORAGE

If not using the tower fan for an extended period of time, cover the tower fan and store in a cool, dry place to avoid moisture damage.

Troubleshooting

Problem	Possible Solution
Tower fan will not turn on or respond to button controls.	Plug in the tower fan.
	Check to see if the power cord is damaged. If so, stop using the tower fan and contact Customer Support (see page 23).
	Plug the tower fan into a different outlet.
	Tower fan may be malfunctioning. Contact Customer Support (see page 23).
Tower fan makes an unusual noise while the fan is on.	Make sure the tower fan is operating on a hard, flat, level surface.
	Tower fan may be damaged, or a foreign object may be inside. Stop using the tower fan and contact Customer Support (see page 23). Do not try to repair the tower fan.
Tower fan randomly turns off.	Tower fan is malfunctioning. Stop using the tower fan and contact Customer Support (see page 23).

If your problem is not listed, please contact **Customer Support** (see page 23).

VeSync App Troubleshooting

My Smart Tower Fan Isn't Connecting to the VeSync App.

- Make sure your phone has Bluetooth® turned on and is not currently connected to another Bluetooth device.
- During the setup process, you must be on a secure 2.4GHz Wi-Fi network. Confirm that the network is working correctly.
- Make sure the Wi-Fi password you entered is correct.
 - a. There should be no spaces at the beginning or end of the password.
 - b. Test the password by connecting a different electronic device to the router.
 - c. If you're manually typing in the SSID and password, double check that both are entered correctly.
- Try moving your tower fan closer to the router. Your phone should be as close as possible to your tower fan.
- Your router may need to be at a higher location, away from obstructions.
- Make sure your tower fan and router are away from appliances (such as microwave ovens, refrigerators, electronic devices, etc.) to avoid signal interference.
- If you're using a VPN, make sure it's turned off while setting up your tower fan.
- Disable portal authentication for your Wi-Fi network. If portal authentication is enabled, the tower fan will not be able to access your Wi-Fi network, and setup will fail.

Note: *Portal authentication means that you need to sign in to your Wi-Fi network through a web page before you can use the Internet.*

My Smart Tower Fan is Offline.

- Make sure the tower fan is plugged in and has power, then refresh the VeSync menu by swiping down on the screen.
- Make sure your router is connected to the internet and your phone's network connection is working.
- Delete the offline tower fan from the VeSync app. Swipe left (iOS®) or press and hold (Android™), then tap **Delete**. Reconfigure the tower fan with the VeSync app.

Note: *Power outages, internet outages, or changing Wi-Fi routers may cause the tower fan to go offline.*

If your problem is not listed, please contact Customer Support (see page 23).

Federal Communication Commission Interference Statement - Part 15

This device complies with Part 15 of the FCC Rules. Operation is subject to the following two conditions:

1. This device may not cause harmful interference, and
2. This device must accept any interference received, including interference that may cause undesired operation.

NOTE: This equipment has been tested and found to comply with the limits for a Class B digital device, pursuant to Part 15 of the FCC Rules. These limits are designed to provide reasonable protection against harmful interference in a residential installation. This equipment generates, uses and can radiate radio frequency energy and, if not installed and used in accordance with the instructions, may cause harmful interference to radio communications. However, there is no guarantee that interference will not occur in a particular installation. If this equipment does cause harmful interference to radio or television reception, which can be determined by turning the equipment off and on, the user is encouraged to try to correct the interference by one or more of the following measures:

1. Reorient or relocate the receiving antenna.
2. Increase the separation between the equipment and receiver.
3. Connect the equipment into an outlet on a circuit different from that to which the receiver is connected.
4. Consult the dealer or an experienced radio/TV technician for help.

FCC Caution: Any changes or modifications not expressly approved by the party responsible for compliance could void the user's authority to operate this equipment.

FCC Radiation Exposure Statement

This equipment complies with FCC radiation exposure limits set forth for an uncontrolled environment. End users must follow the specific operating instructions for satisfying RF exposure compliance. To maintain compliance with FCC RF exposure compliance requirements, please follow operation instructions as documented in this manual. This transmitter must not be co-located or operating in conjunction with any other antenna or transmitter. This equipment should be installed and operated with a minimum distance of 20 cm between the radiator and your body. The availability of some specific channels and/or operational frequency bands are country dependent and are firmware programmed at the factory to match the intended destination. The firmware setting is not accessible by the end user.

FCC SDOC SUPPLIER'S DECLARATION OF CONFORMITY

Vesync (US) Corporation hereby declares that this equipment is in compliance with the FCC requirements. The declaration of conformity may be consulted in the support section of our website, accessible from <https://www.vesync.com/legal/compliance/fcc>

Limited Warranty Information

Product	Windi Lift Pro Tower Fan
Model	LTF-F461S-AUS
Order ID	
Date of Purchase	

Levoit Limited Product Warranty

Register your products at <https://warranty.levoit.com/warranty> to stay up to date with important product information such as product updates, limited warranties, usage and maintenance recommendations, and notifications concerning safety warnings or product recalls. Registration is not required to claim your limited warranty.

Two (2) Year Limited Consumer Product Warranty

Vesync (US) Corporation ("Vesync") warrants that the product shall be free from defects in material and workmanship for a period of **2 years from the date of original purchase** ("Limited Warranty Period"), provided the product was used in accordance with its use and care instructions (e.g., in the intended environment and under normal circumstances).

California Residents Only

The Warranty Period begins on the original date of delivery or pick-up.

Your Limited Warranty Benefits

During the Limited Warranty Period and subject to this limited Warranty Policy, Vesync will, in its sole and exclusive discretion, either (i) refund the purchase price if the purchase was made directly from the online Levoit store, (ii) repair any defects in material or workmanship, (iii) replace the product with another product of equal or greater value, or (iv) provide store credit in the amount of the purchase price.

Who Is Covered?

This limited warranty extends only to the original consumer purchaser of the product and is not transferable to any subsequent owner of the product, regardless of whether the product transferred ownership during the specified term of the limited warranty. The original consumer purchaser must provide verification of the defect or malfunction and proof of the date of purchase to claim the Limited Warranty Benefits.

Be Aware of Unauthorized Dealers or Sellers

This limited warranty does not extend to products purchased from unauthorized dealers or sellers. Vesync's limited warranty only extends to products purchased from authorized dealers or sellers that are subject to Vesync's quality controls and have agreed to follow its quality controls. Please be aware, products purchased from an unauthorized website or dealer may be counterfeit, used, defective, or may not be designed for use in your country. You can protect yourself and your products by making sure you only purchase from Vesync or its authorized dealers.

If you have any questions about a specific seller, or if you think you may have purchased your product from an unauthorized seller, please contact our Customer Support Team via support.levoit.com.

What's Not Covered?

- Normal wear and tear, including parts that might wear out over time (e.g., batteries, filters, cleaning brush, essential oil pads, etc.).
- If the proof-of-purchase has been altered in any way or is made illegible.
- If the model number, serial number or production date code on the product has been altered, removed or made illegible.
- If the product has been modified from its original condition.
- If the product has not been used in accordance with directions and instructions in the user manual.
- Damages caused by connecting peripherals, additional equipment or accessories other than those recommended in the user manual.
- Damages or defects caused by accident, abuse, misuse, or improper or inadequate maintenance.
- Damages or defects caused by service or repair of the product performed by an unauthorized service provider or by anyone other than Vesyinc.
- Damages or defects occurring during commercial use, rental use, or any use for which the product is not intended.
- If the unit has been damaged, including but not limited to damage by animals, lightning, abnormal voltage, fire, natural disaster, transportation, dishwasher, or water (unless the user manual expressly states that the product is dishwasher-safe).
- Incidental and consequential damages.
- Damages or defects exceeding the cost of the product.

Claiming Your Limited Warranty Service in 5 Simple Steps:

1. Make sure your product is within the specified limited warranty period.
2. Make sure you have a copy of the invoice and order ID or proof-of-purchase.
3. Make sure you have your product.
DO NOT dispose of your product before contacting us.
4. Contact our Customer Support Team via support.levoit.com.
5. Once our Customer Support Team has approved your request, please return the product with a copy of the invoice and order ID.

Sole and Exclusive Remedy

THE FOREGOING LIMITED WARRANTY CONSTITUTES VESYINC CORPORATION'S EXCLUSIVE LIABILITY, AND YOUR SOLE AND EXCLUSIVE REMEDY, FOR ANY BREACH OF ANY WARRANTY OR OTHER NONCONFORMITY OF THE PRODUCT COVERED BY THIS LIMITED PRODUCT WARRANTY STATEMENT. THIS LIMITED WARRANTY IS EXCLUSIVE, AND IN LIEU OF ALL OTHER WARRANTIES. NO EMPLOYEE OF VESYINC CORPORATION OR ANY OTHER PARTY IS AUTHORIZED TO MAKE ANY WARRANTY IN ADDITION TO THE LIMITED WARRANTY IN THIS LIMITED PRODUCT WARRANTY STATEMENT.

Disclaimer of Limited Warranties

TO THE FULLEST EXTENT PROVIDED BY APPLICABLE LAW, EXCEPT AS WARRANTED IN THIS LIMITED PRODUCT WARRANTY POLICY, VESYINC CORPORATION PROVIDES THE PRODUCTS YOU PURCHASE FROM VESYINC CORPORATION "AS IS" AND VESYINC CORPORATION HEREBY DISCLAIMS ALL WARRANTIES OF ANY KIND, WHETHER EXPRESS OR IMPLIED, STATUTORY, OR OTHERWISE, INCLUDING BUT NOT LIMITED TO ANY WARRANTIES OF MERCHANTABILITY, NON-INFRINGEMENT, AND FITNESS FOR PARTICULAR PURPOSE.

Limitations of Liability

TO THE FULLEST EXTENT PROVIDED BY APPLICABLE LAW, IN NO EVENT WILL VESYNC CORPORATION, ITS AFFILIATES, OR THEIR LICENSORS, SERVICE PROVIDERS, EMPLOYEES, AGENTS, OFFICERS, OR DIRECTORS BE LIABLE FOR:

(a) DAMAGES OF ANY KIND ARISING OUT OF OR IN CONNECTION WITH PRODUCTS PURCHASED FROM VESYNC CORPORATION IN EXCESS OF THE PURCHASE PRICE PAID BY THE PURCHASER FOR SUCH PRODUCTS, OR

(b) INDIRECT, SPECIAL, INCIDENTAL, CONSEQUENTIAL, OR PUNITIVE DAMAGES EVEN IF VESYNC CORPORATION OR ONE OF ITS SUPPLIERS HAS BEEN ADVISED OF THE POSSIBILITY OR LIKELIHOOD OF SUCH DAMAGES.

AND REGARDLESS OF WHETHER CAUSED BY TORT (INCLUDING NEGLIGENCE), BREACH OF CONTRACT, OR OTHERWISE. OUR LIABILITY SHALL UNDER NO CIRCUMSTANCES EXCEED THE ACTUAL AMOUNT PAID BY YOU FOR THE DEFECTIVE PRODUCT, NOR SHALL WE UNDER ANY CIRCUMSTANCES BE LIABLE FOR ANY CONSEQUENTIAL, INCIDENTAL, SPECIAL OR PUNITIVE DAMAGES OR LOSSES, WHETHER DIRECT OR INDIRECT.

EXCEPT AS COVERED BY THIS LIMITED PRODUCT WARRANTY STATEMENT, VESYNC CORPORATION SHALL NOT BE LIABLE FOR COSTS ASSOCIATED WITH THE REPLACEMENT OR REPAIR OF PRODUCTS PURCHASED FROM IT, INCLUDING, BUT NOT LIMITED TO, LABOR, INSTALLATION, OR OTHER COSTS INCURRED BY THE USER AND, IN PARTICULAR, ANY COSTS RELATING TO THE REMOVAL OR REPLACEMENT OF ANY PRODUCT.

OTHER RIGHTS YOU MAY HAVE

SOME JURISDICTIONS DO NOT ALLOW FOR: (1) EXCLUSION OF IMPLIED WARRANTIES; (2) LIMITATION ON THE DURATION OF IMPLIED WARRANTIES; AND/OR (3) EXCLUSION OR LIMITATION OF INCIDENTAL OR CONSEQUENTIAL DAMAGES; SO THE DISCLAIMERS IN THIS POLICY MAY NOT APPLY TO YOU. IN THESE JURISDICTIONS YOU HAVE ONLY THE IMPLIED WARRANTIES THAT ARE EXPRESSLY REQUIRED TO BE PROVIDED IN ACCORDANCE WITH APPLICABLE LAW. THE LIMITATIONS OF WARRANTIES, LIABILITY, AND REMEDIES APPLY TO THE MAXIMUM EXTENT PERMITTED BY LAW.

ALTHOUGH THIS LIMITED WARRANTY GIVES YOU SPECIFIC LEGAL RIGHTS, YOU MAY HAVE OTHER RIGHTS IN YOUR JURISDICTION. THIS STATEMENT OF LIMITED WARRANTY IS SUBJECT TO APPLICABLE LAWS THAT APPLY TO YOU AND THE PRODUCT. PLEASE REVIEW THE LAWS IN YOUR JURISDICTION TO UNDERSTAND YOUR RIGHTS FULLY.

CHANGES TO THIS POLICY

We may change the terms and availability of this limited warranty at our discretion, but any changes will not be retroactive.

This warranty is made by:

Vesync (US) Corporation

1775 Flight Way, Suite 150
Tustin, CA 92782
USA

Customer Support

If you have any questions or concerns about your new product, please contact our Customer Support Team.

Vesync (US) Corporation

1775 Flight Way, Suite 150

Tustin, CA 92782

USA

Website: support.levoit.com

Toll-Free: 1-888-726-852

SUPPORT HOURS

Mon–Fri, 9:00 am–5:00 pm PST/PDT

**Please have your order invoice PDF or screenshot(s) ready before contacting Customer Support.*

Attributions

App Store® is a trademark of Apple Inc.

Google, Android, and Google Play are trademarks of Google LLC.

Wi-Fi is a registered trademark of Wi-Fi Alliance®.

Amazon, Alexa and all related logos are trademarks of Amazon.com, Inc. or its affiliates.

iOS is a registered trademark of Cisco Systems, Inc. and/or its affiliates in the United States and certain other countries.

The Bluetooth® word mark and logos are registered trademarks owned by Bluetooth SIG, Inc. and any use of such marks by VESYNC (SINGAPORE) PTE. LTD. is under license. Other trademarks and trade names are those of their respective owners.

lěvoit

by VeSync