

ROWER-445 OWNER'S MANUAL

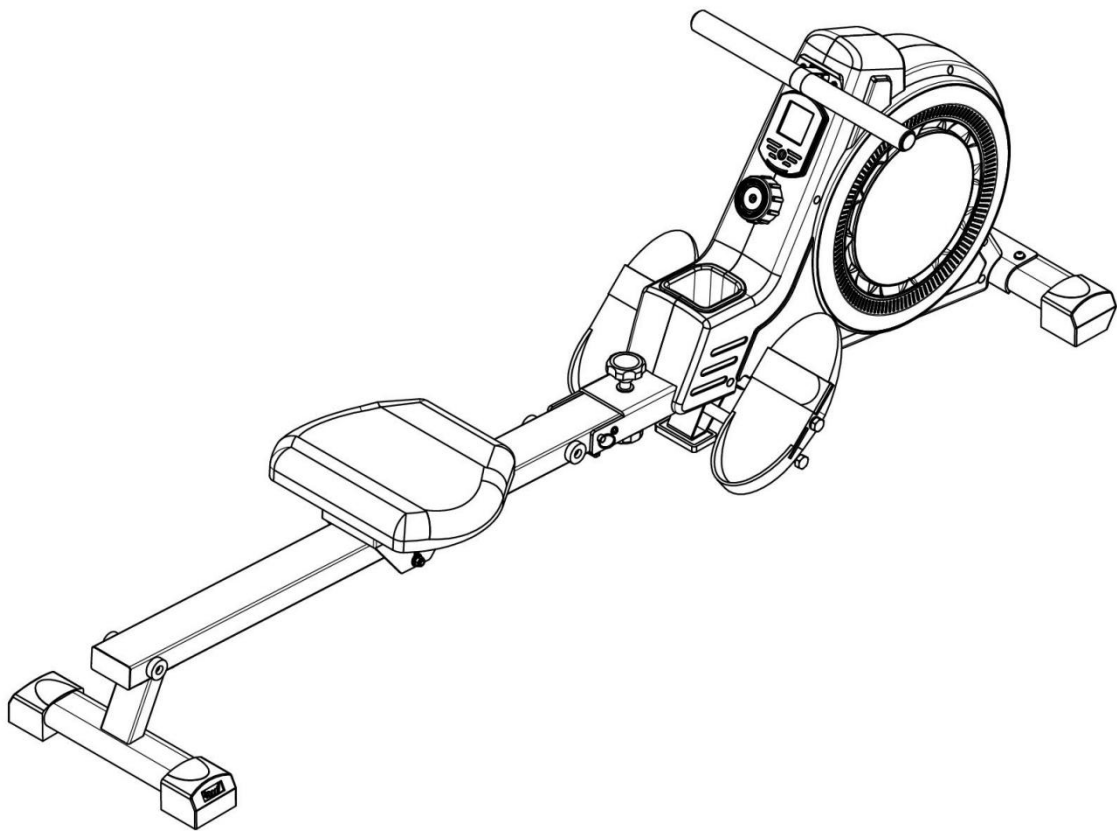

Product may vary slightly from the item pictured due to model upgrades

Read all instructions carefully before using this product. Retain this owner's manual for future reference.

TABLE OF CONTENTS

1.	IMPORTANT SAFETY INSTRUCTIONS	3
2.	CARE INSTRUCTIONS	4
3.	PARTS	5
4.	ASSEMBLY INSTRUCTIONS	8
5.	STORAGE & MAINTENANCE	13
5.	DISPLAY MANUAL	13
6.	EXERCISE GUIDE	14
7.	EXPLODED DIAGRAM	16
8.	WARRANTY	17

1. IMPORTANT SAFETY INSTRUCTIONS

WARNING - Read all instructions before using this machine.

It is important your machine receives regular maintenance to prolong its useful life. Failing to regularly maintain your machine may void your warranty.

Please always keep this manual with you

- a. It is important to read this entire manual before assembling and using the equipment. Safe and effective use can only be achieved if the equipment is assembled, maintained and used properly.
Please note: It is your responsibility to ensure that all users of the equipment are informed of all warnings and precautions.
- b. Before starting any exercise program, you should consult your doctor to determine if you have any medical or physical conditions that could put your health and safety at risk or prevent you from using the equipment properly. Your doctor's advice is essential if you are taking medication that affects your heart rate, blood pressure or cholesterol level.
- c. Be aware of your body's signals. Incorrect or excessive exercise can damage your health. Stop exercising if you experience any of the following symptoms: pain, tightness in your chest, irregular heartbeat, and extreme shortness of breath, lightheadedness, dizziness or feelings of nausea. If you do experience any of these symptoms, you should consult your doctor before continuing with your exercise program.
- d. Keep children and pets away from the equipment. This equipment is designed for adult use only.
- e. Use the equipment on a solid, flat level surface with a protective cover for your floor or carpet. To ensure safety, the equipment should have at least 2 meters of free space around it.
- f. Before using the equipment, check that the nuts and bolts are securely tightened. If you hear any unusual noises coming from the equipment during use and assembly, stop immediately. Do not use the equipment until the problem has been rectified.
- g. Wear suitable clothing while using the equipment. Avoid wearing loose clothing that may get caught in the equipment or that may restrict or prevent movement.

- h. This equipment is designed for indoor and family use only
- i. Care must be taken when lifting or moving the equipment so as not to injure your back.
- j. Always keep this instruction manual and assembly tools at hand for reference.
- k. The equipment is not suitable for therapeutic use.
- l. The pulse or heart rate sensors are not medical devices. Various factors, including the user's movement, may affect the accuracy of heart rate readings. The pulse sensors are intended only as exercise aids in determining heart rate trends in general.

2. CARE INSTRUCTIONS

- a. Lubricate moving joints with grease after periods of usage
- b. Be careful not to damage plastic or metal parts of the machine with heavy or sharp objects
- c. The machine can be kept clean by wiping it down using dry cloth
- d. All nuts and bolts are to be checked and tightened on a regular basis. This includes pedals and other moving parts. Failure to do so may cause damage to your thread and void your warranty.

Battery Usage

- a. Batteries are to be installed or replaced by adult only
- b. Do not use rechargeable batteries. Do not mix different battery types. Do not mix old and new batteries. Do not mix alkaline, standard (Carbon-Zinc), or rechargeable (Nickel-Cadmium) batteries
- c. Remove batteries when product is not in use
- d. Remove exhausted batteries from product and dispose of in accordance with the manufacturer's recommendation
- e. Do not attempt to recharge non-rechargeable batteries
- f. Batteries are to be inserted with correct polarity
- g. The supply terminals are not to be short-circuited
- h. Do not dispose of batteries in fire, batteries may explode or leak



3.PARTS

No.	Description	Spec.	Qty.	No.	Description	Spec.	Qty.
1	Main frame		1	63	Cotton knob M12	M12	1
2	Front foot tube frame		1	64	Foot pad $\Phi 30 \times 18$	$\Phi 30 \times 18$	1
3	Rear foot tube frame		1	10	The hanging ring bolt	$\Phi 8 \times 112$	1
4	Slide tube frame		1	27	Bolt M12*160*20	M12*160*20	4
8	Seat cushion right mounting plate		1	30	Bolt M10*95	M10*95	1
57	Seat cushion		1	29	Bolt M8*50	M8*50	2
48	Pedal		2	32	Bolt M6*15	M6*15	1
18	Wrench S17-19	S17-19	1	31	Hexagon socket button head screws	M8*20	8
19	Allen Wrench S=5	S=5	1	37	Flat washer	$\Phi 12$	1
20	Allen Wrench S=6	S=6	1	38	Washer	$\Phi 6$	1
21	Allen Wrench S13/14/15	S13, 14, 15	1	39	Washer	$\Phi 8$	10
9	Double screw $\Phi 12 \times 80$	$\Phi 12 \times 80$	1	41	Standard Washer	8	10

Install Tool:

#19 Allen Wrench S=5 1PC

#20 Allen Wrench S=6 1PC

#18 Wrench S17, 19 1PC



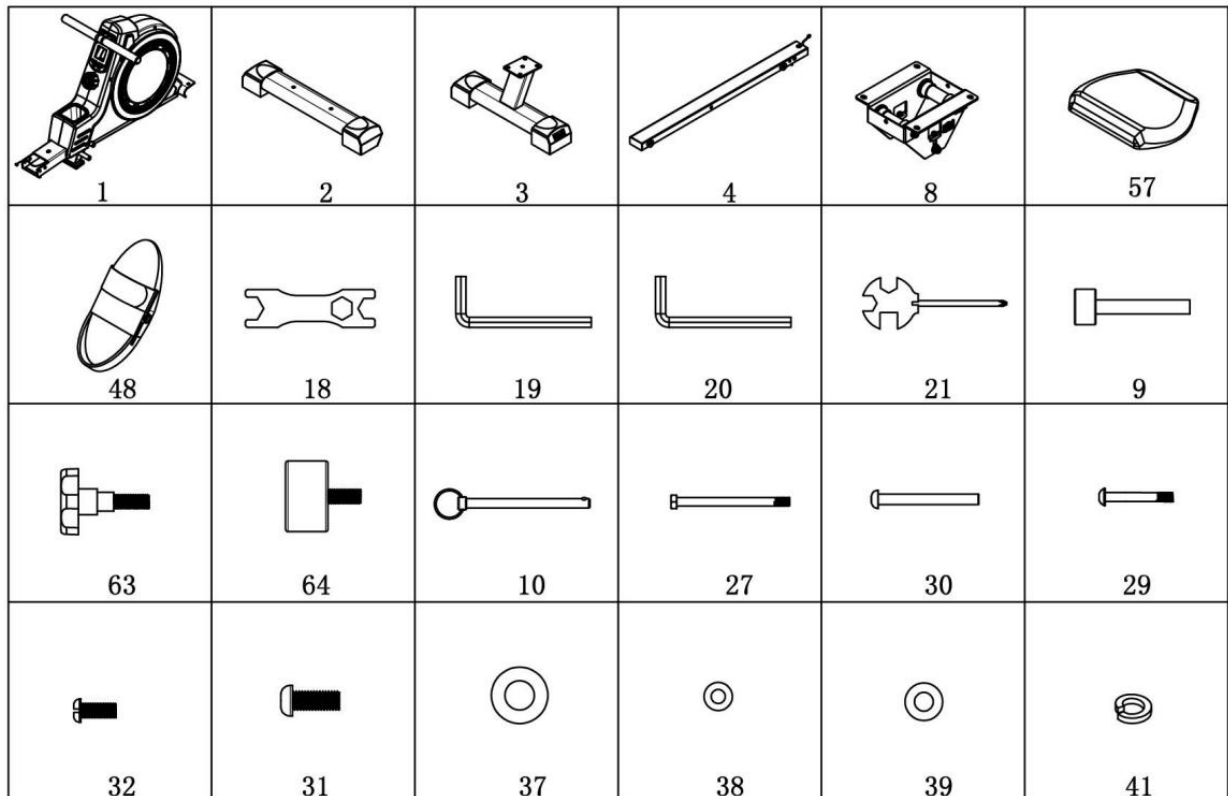











#21 Wrench S13, 14, 15 1PC

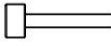

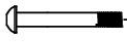
TOTAL PARTS LIST

No.	Description	Qty.	No.	Description	Qty
1	Main frame	1	34	Bolt M5*15	3
2	Front foot tube frame	1	36	Bolt ST4.2*30	4
3	Rear foot tube frame	1	37	Washer Φ12	1
4	Slide tube frame	1	38	Washer Φ6	2
5	Tension tube	1	39	Washer Φ8	16
6	Seat cushion limiting plate	1	40	Standard Washer 6	1
7	Seat cushion left mounting plate	1	41	Standard Washer 8	10
8	Seat cushion right mounting plate	1	42	Type c buckle φ9.3*1.0	2
9	Double screw Φ12*80	1	43	Left protective cover	1
10	The hanging ring bolt Φ8*112	1	44	Right protective cover	1
11	Magnetic wheel	1	45	Water bottle box	1
12	Deep groove ball bearing 608-2RS	6	46	Armrest fixing pad	1
13	Deep groove ball bearing 6000-2RS	2	47	Cushion pad	1
14	Slide tube	1	48	Pedal	2
15	Pulley spacer	6	49	Belt PJ686/270J	1
16	Pull rod M6*51	4	50	Ribbon pulley Φ45*35	1
17	Pull rod limiting plate	4	51	Foam Grip L=210mm	2
18	Wrench S17-19	1	52	Foot pedal adjusting belt	2
19	Allen Wrench S=5	1	53	Thread plugΦ15*Φ5*13.5	2
20	Allen Wrench S=6	1	54	Fine adjustment (assembly)	1
21	Wrench S13/14/15	1	55	Puller	1
22	Screw M6	4	56	Seat cushion tube wheel Φ40*92	3
23	Screw M8	3	57	Seat Pad	1
24	Screw M10*1.0	4	58	Front left foot sleeve	1
25	Screw M10*1.0	4	59	Front right foot sleeve	1
26	Bolt M8*125*25	3	60	Rear foot sleeve	2
27	Bolt M12*160*20	4	61	Circular tube plug	2
28	Bolt M6*60	1	62	Encapsulated magnetΦ18*13	1
29	Bolt M8*50	2	63	plum blossom knob M12	1
30	Bolt M10*95	1	64	foot pad Φ30*18	4
31	Hexagon socket button head screws	8	65	computer	1
32	Bolt M6*15	1	66	Sensor Length 750mm	1
33	Bolt M6*20	4	67	Diddle wire 650mm	1
35	Bolt ST4.2*30	6			

TOOL BAG

	#19 S=5 1PC
	#20 S=6 1PC
	#21 S13/14/15 1PC
	#18 S17-19 1PC
	#64 $\varnothing 38*18$ 1PC
	#63 M12 1PC
	#9 $\varnothing 12*80$ 1PC
	#10 $\varnothing 8*112$ 1PC
	#27 M12*160*20 4PCS
	#30 M10*95*25 1PC
	#29 M8*50*20 2PCS
	#32 M6*15 1PC
	#31 M8*20 8PCS
	#37 $\varnothing 12$ 1PC
	#39 $\varnothing 8$ 10PCS
	#38 $\varnothing 6$ 1PC
	#41 M8 10PCS

4.ASSEMBLY INSTRUCTIONS

STEP 1

1. Secure the bolt (29), washer $\Phi 8$ (39), standard washer $\Phi 8$ (41) to the main frame (1).

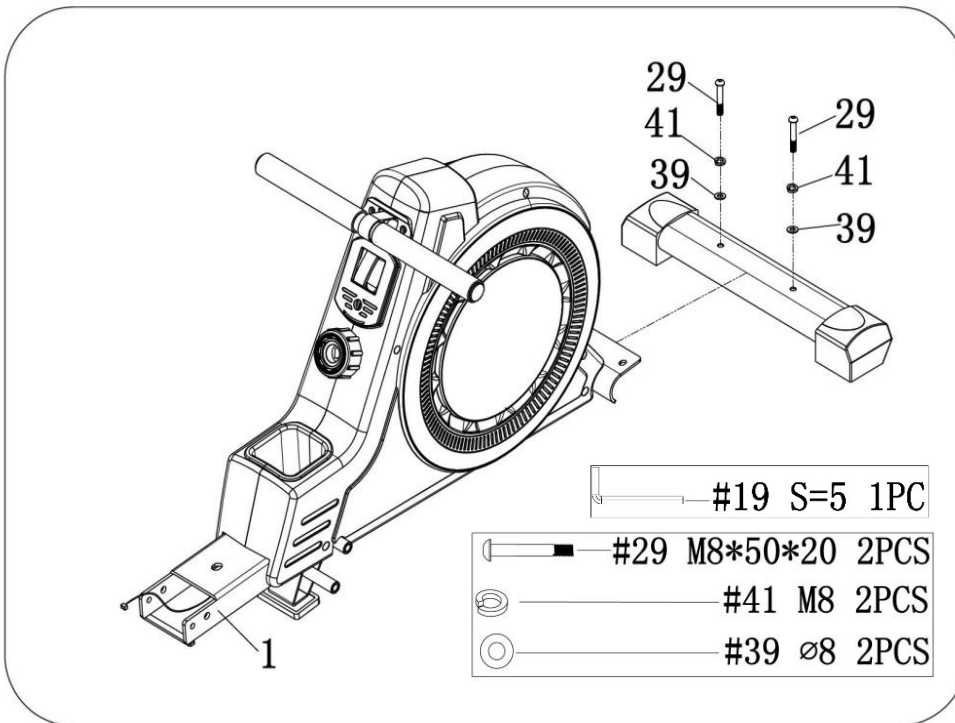

STEP 2

1. Refer to picture of place A: Lock the bolt (27) M12*160*20 through the hole under the main frame (1).
2. The bolt M12*160*20 (27) passes through the pedal (48) and is locked on a hole on the main frame (1), and the bottom of the pedal needs to be placed on the lower bolt.

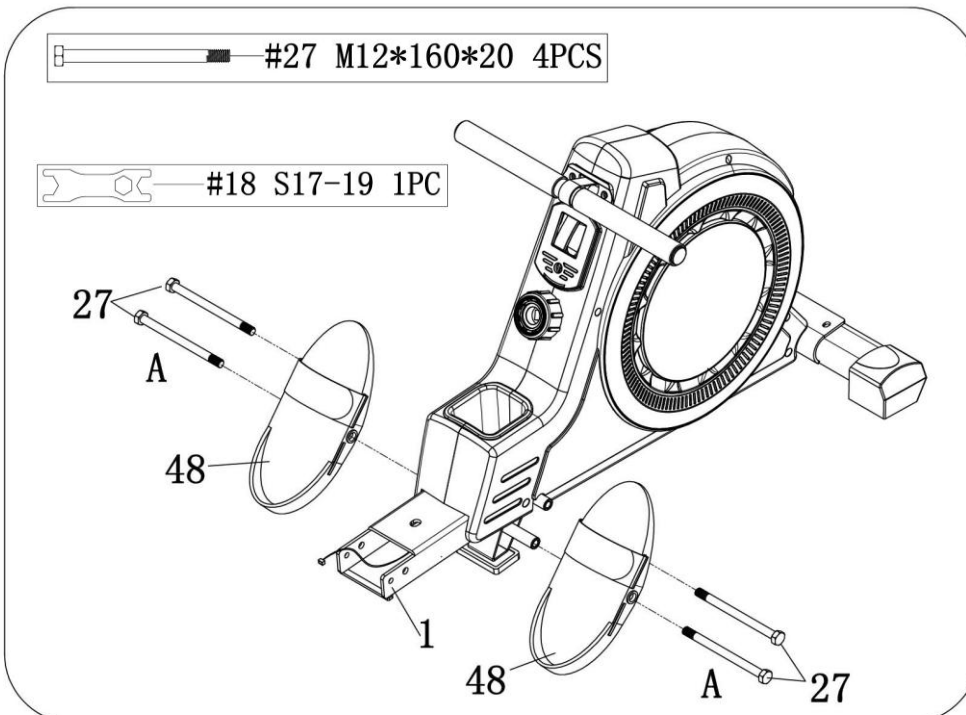

STEP 3

1. Hexagon socket button head screws (31), standard Washer (41) and flat washer (39) are used to secure the seat cushion base (8) and seat cushion (57). Tighten the bolts.

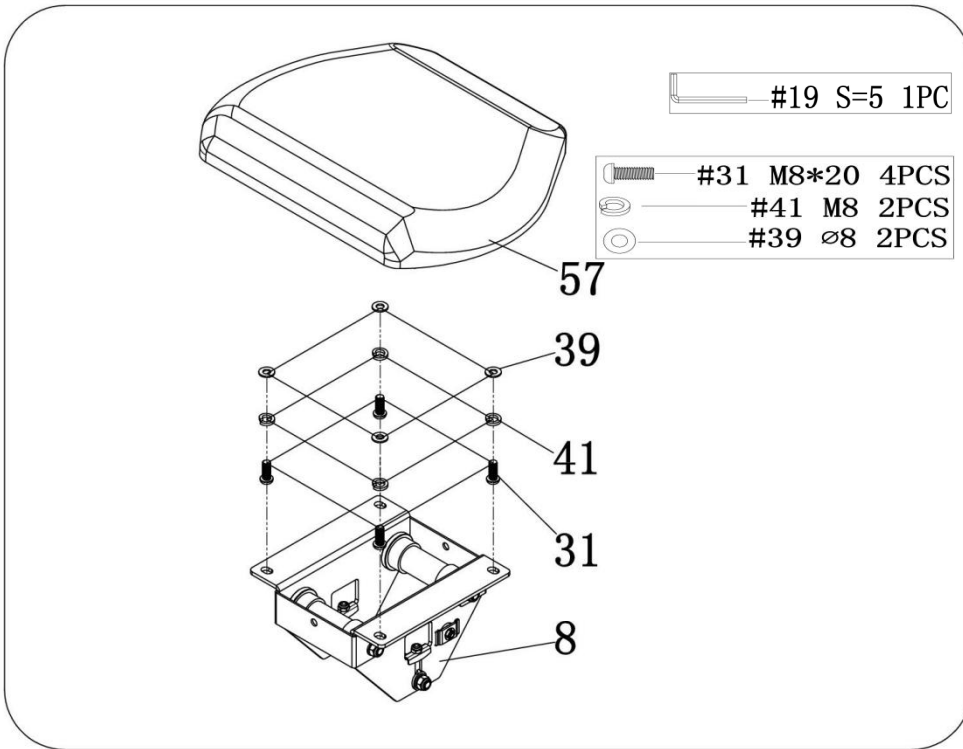

STEP 4

1. Install the seat cushion (57) into the slide tube (4).
2. Insert the limiting shaft (9) into the hole of the sliding tube (4), and use the pan head screws with bolt (33) to place the foot pad (64)
3. Tight to sliding tube.

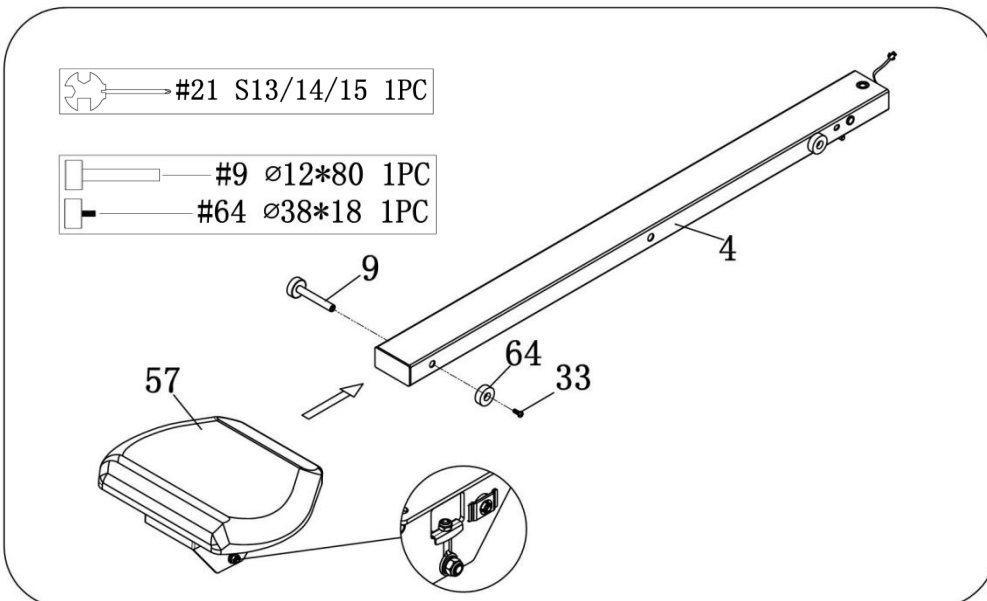

When installing, the magnet is oriented to the right-hand side.

STEP 5

1. Use Bolt (31), Standard Washer (41) and flat washer (39) to lock the rear leg tube (3) to the sliding tube (4).

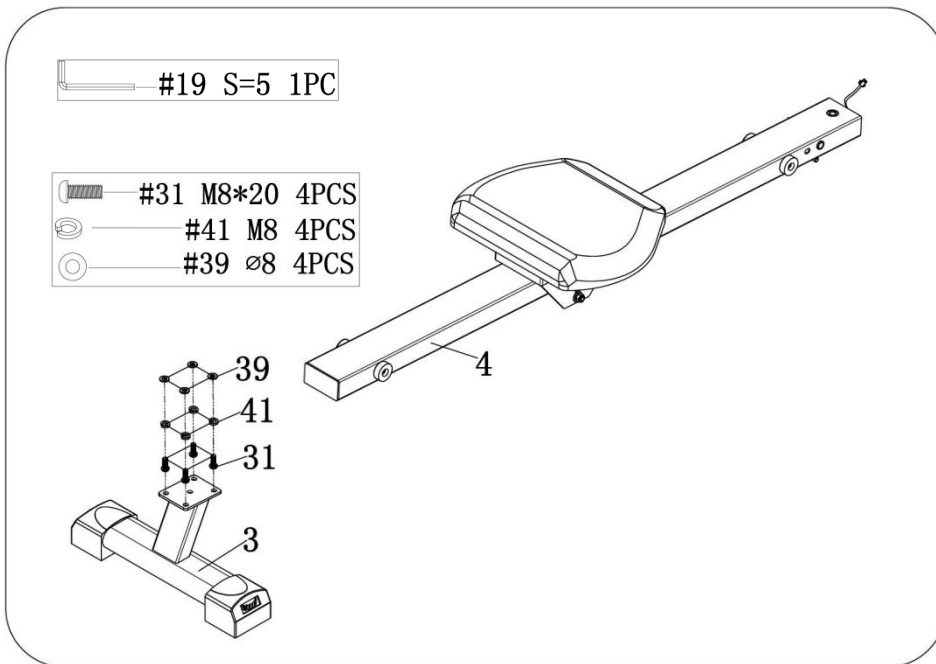

STEP 6

1. Connect the trunk line (67) with the sensing line (66).
2. Lock the bolt (30) and the flat washer (38) and bolt (32) to the sliding tube (4), insert the hanging ring bolt (10), and then fix the plum blossom knob (63) and the flat washer (37) to the main frame (1) and the sliding tube (4).

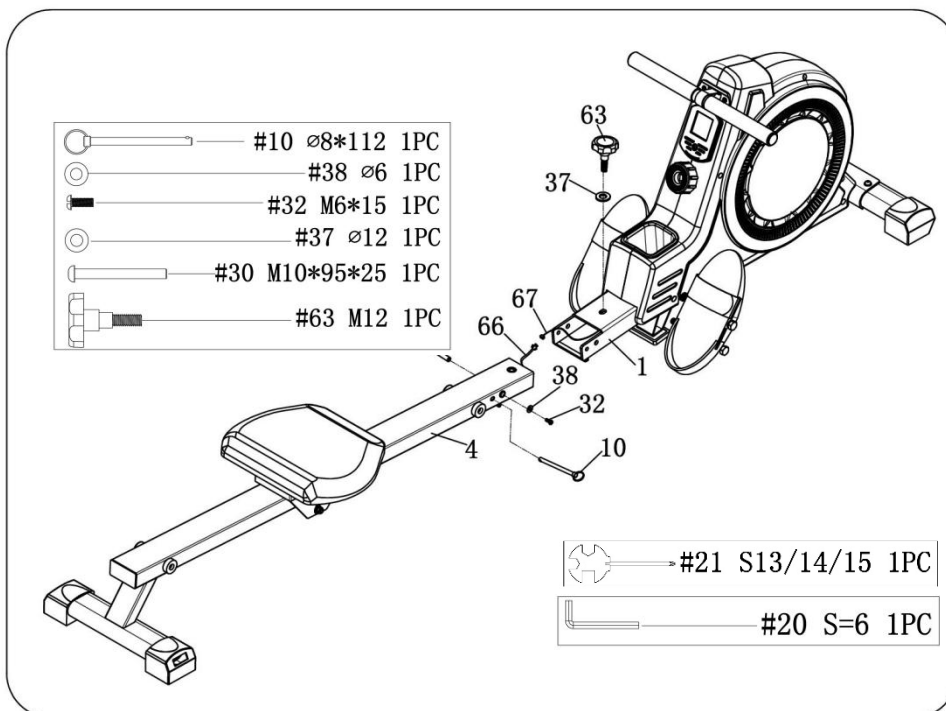

Pedal Adjustment

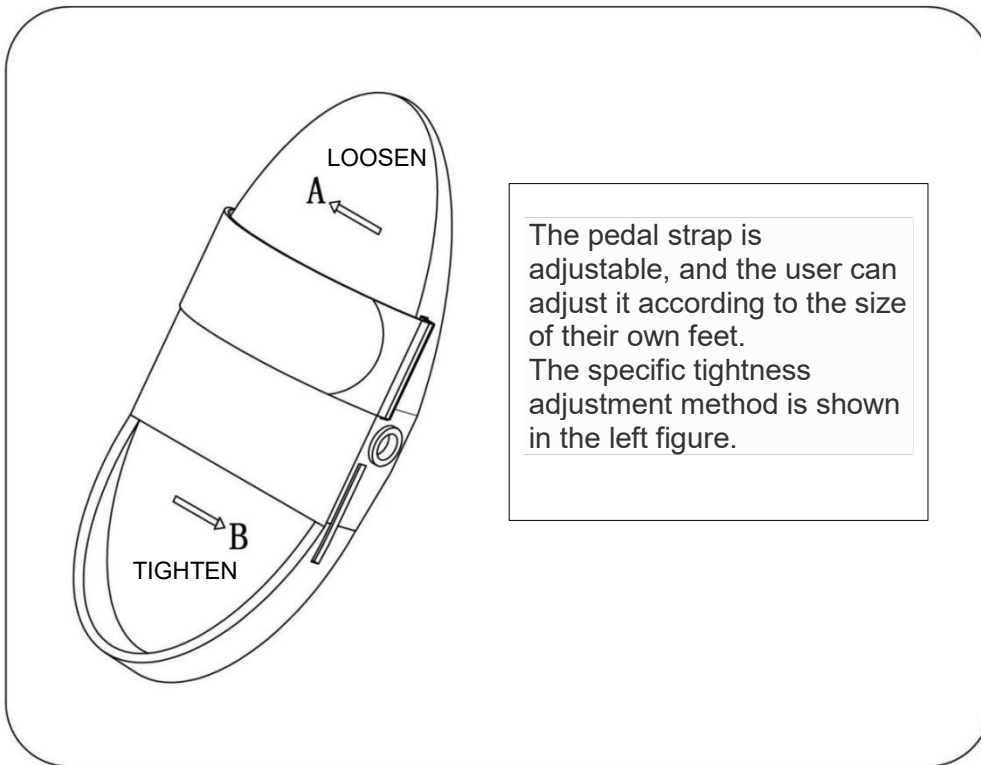

Moving the machine

To move the machine, lift the rear stabilizer until the transportation wheels on the front stabilizer touch the ground. With the wheels on the ground, you can transport the bike to the desired location with ease.

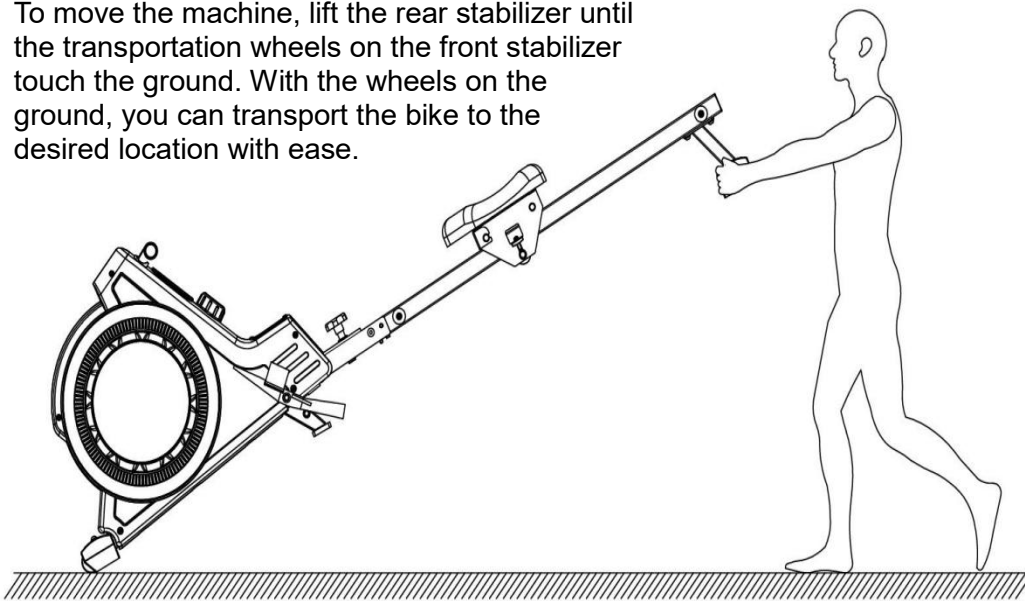

Adjusting resistance level

Rotate the Tension Control Knob (No. 34) clockwise to increase the level of resistance. Rotate the tension control counter-clockwise to decrease the level of resistance.

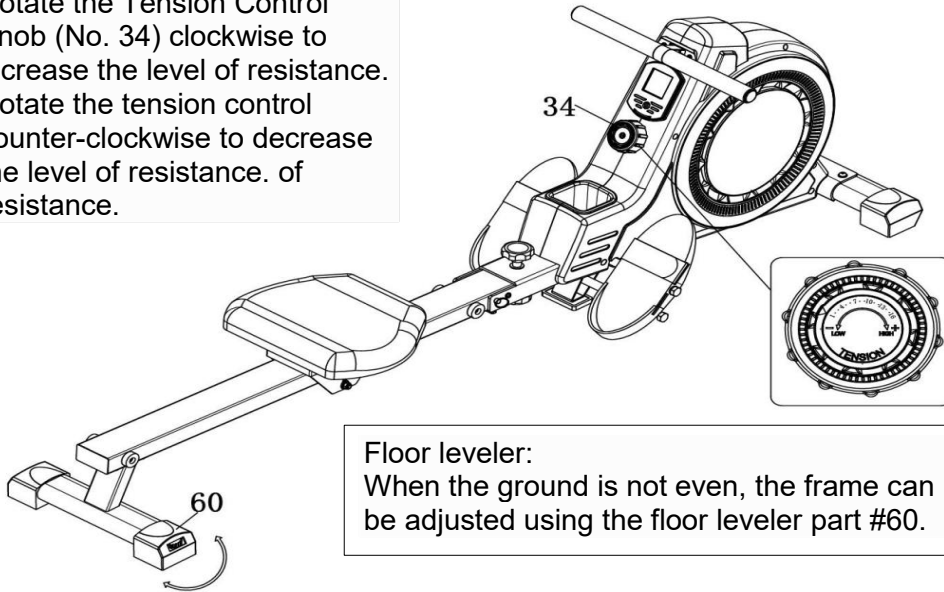

Floor leveler:
When the ground is not even, the frame can be adjusted using the floor leveler part #60.

Folding instructions

Attention!
Be careful when folding the sliding tube as it may collide with the main body and seat cushion will slide done.

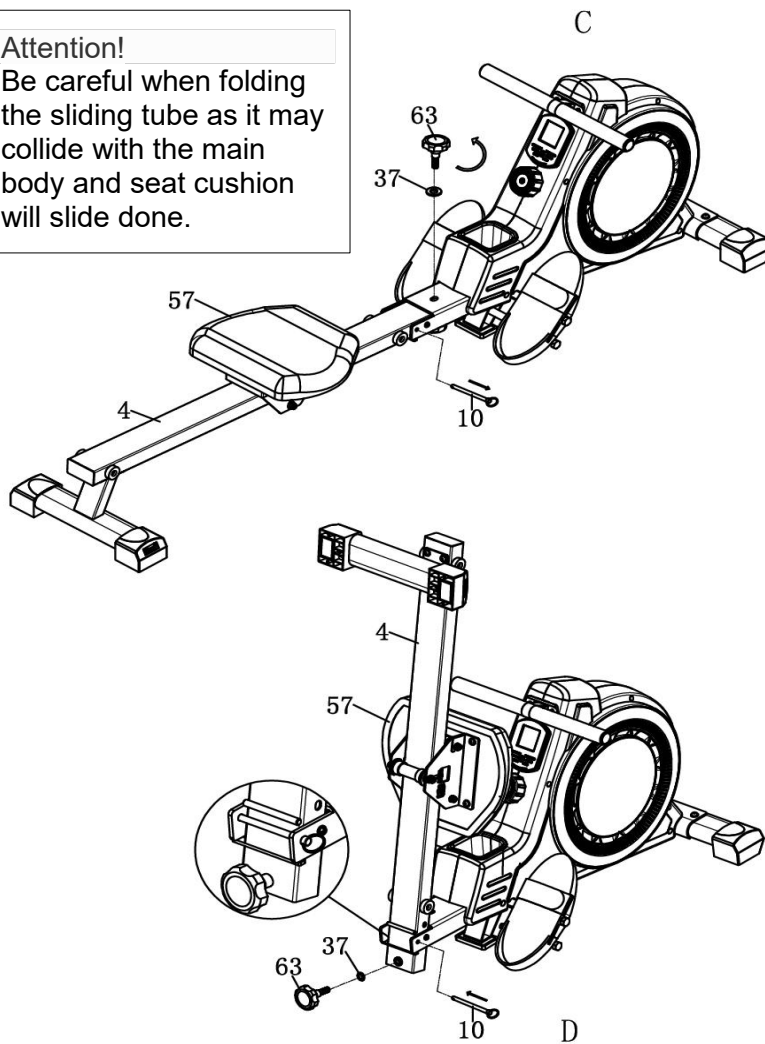

As shown in the above figure, when the product is not used, the sliding tube can be turned up to avoid occupying space.

Instruction:

1. Unscrew the plum blossom knob (63) and the flat washer (37), remove the hanging ring bolt (10), and turn the sliding tube (4) to a vertical angle. (The seat cushion slides down when the slide tube is turned up) Figure D above.
2. When the sliding tube (4) rotates to a vertical angle, insert the hanging ring bolt (10) into the hole and fix it. Rotate the plum blossom knob (63) and flat washer (37) onto the sliding tube, as shown in Figure C above.
3. Folding is completed.

5. STORAGE & MAINTENANCE

1. Keep the rowing machine in a clean dry place.
2. Grasp the frame to move the rowing machine. Do not use the seat to move it. The seat will move, and it may hurt your hand and fingers.
3. Remove the battery before storing the machine for a long time.
4. Clean the Seat Rail with an absorbent cloth.
5. Always make sure all the nuts and bolts are properly tightened.
6. Regular inspection is required. Replace any worn or damaged parts immediately.

6. DISPLAY MANUAL



SPECIFICATIONS:

TIME: _____ 00:00 - 99:59 MIN: SEC
COUNT: _____ 0 - 9999 STROKES
CALORIES: _____ 0 - 9999 KCAL
REPS/MIN (STROKES/MIN): _____ 0 - 9999 STROKES/MIN

FUNCTION KEY:

MODE: Press this button to select the function. Press for 3 seconds to clear all time, row (CNT), and calories.

SET: Press this key to set the time, number of times, and calories.

RESET: Press this key to reset the time, number of times, and calories. Press for 3 seconds to clear all time, times, and calories.



FUNCTION OPERATION:

1. **SCAN:** Press the mode key to scan, the display will automatically scan; time; time (CNT); calories; and total number of times. Every scan interval is 6 seconds.
2. **TIME:** Counts the total workout time.
3. **ROW (CNT):** Counts the number of rows during a workout.
4. **CAL:** Calories count at the beginning and end of the display.
5. **TOTAL NUMBER OF ROWS (TOT. CNT):** Counts total of rows from when the battery is installed.

Without any movement signal, the display will automatically shut down after 4 minutes, and will wake up when there is movement signal, or any key is pressed.

7. EXERCISE GUIDE

PLEASE NOTE: Before beginning any exercise program, consult your physician. This is important especially if you are over the age of 45 or individuals with pre-existing health problems.

The pulse sensors are not medical devices. Various factors, including the user's movement, may affect the accuracy of heart rate readings. The pulse sensors are intended only as an exercise aid in determining heart rate trends in general.

Exercising is great way to control your weight, improving your fitness and reduce the effect of aging and stress.

The key to success is to make exercise a regular and enjoyable part of your everyday life.

The condition of your heart and lungs and how efficient they are in delivering oxygen via your blood to your muscles is an important factor to your fitness. Your muscles use this oxygen to provide enough energy for daily activity. This is called aerobic activity. When you are fit, your heart will not have to work so hard. It will pump a lot fewer times per minute, reducing the wear and tear of your heart.

So as you can see, the fitter you are, the healthier and greater you will feel.

Warm-up

Start each workout with 5 to 10 minutes of stretching and some light exercises. A proper warm-up increases your body temperature, heart rate and circulation in preparation for exercise. Ease into your exercise.

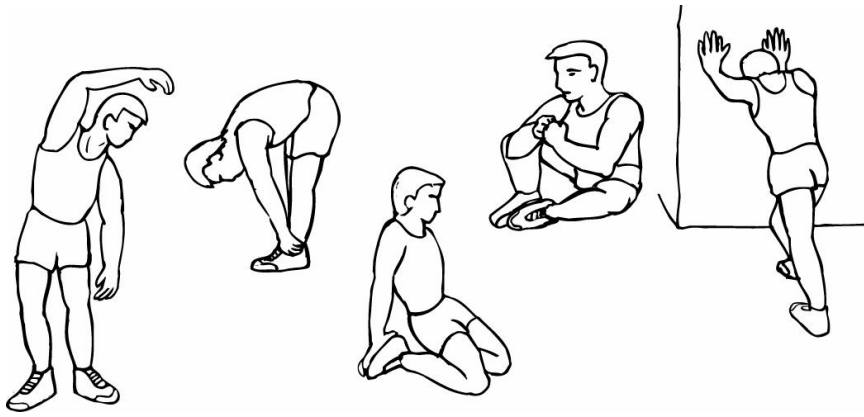

Training Zone Exercise

After warming up, increase the intensity to your desired exercise program. Be sure to maintain your intensity for maximum performance. Breathe regularly and deeply as you exercise.

Cool Down

Finish each workout with a light jog or walk for at least 1 minute. Then complete 5 to 10 minutes of stretching to cool down. This will increase the flexibility of your muscles and will help prevent post-exercise problems.

Workout Guidelines

TARGET ZONE

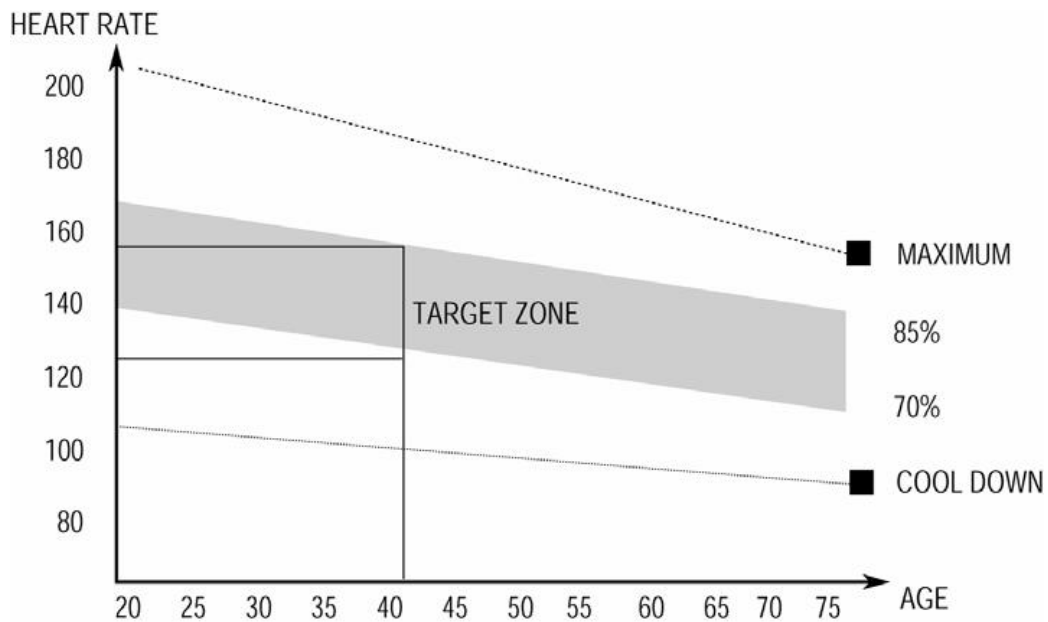

This is how your pulse should behave during general fitness exercise. Remember to warm up and cool down for a few minutes.

8. EXPLODED DIAGRAM

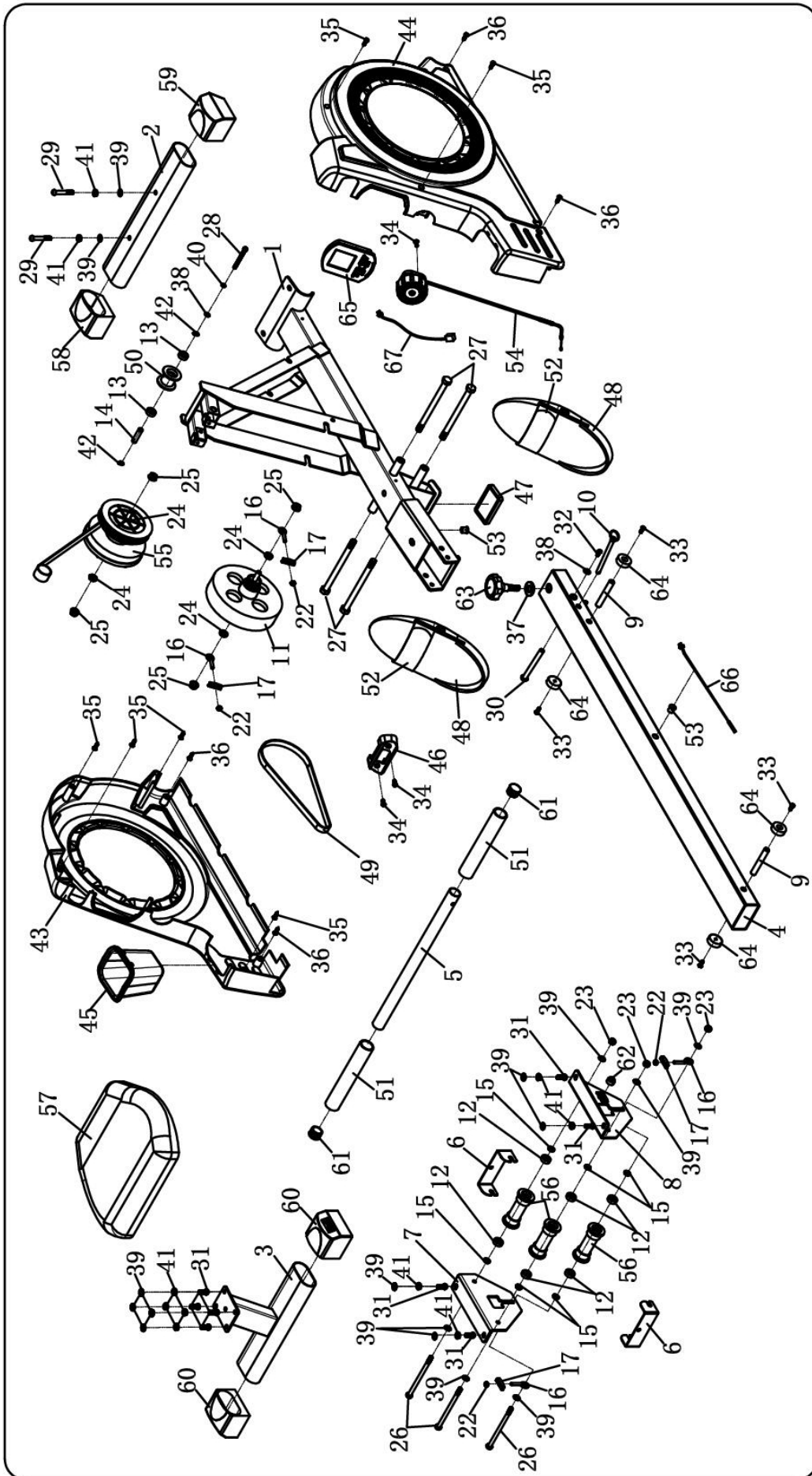

9.WARRANTY

AUSTRALIAN CONSUMER LAW

Many of our products come with a guarantee or warranty from the manufacturer. In addition, they come with guarantees that cannot be excluded under the Australian Consumer Law. You are entitled to a replacement or refund for a major failure and compensation for any other reasonably foreseeable loss or damage.

You are entitled to have the goods repaired or replaced if the goods fail to be of acceptable quality and the failure does not amount to a major failure. Full details of your consumer rights may be found at www.consumerlaw.gov.au

Please visit our website to view our full warranty terms and conditions:

<http://www.lifespanfitness.com.au/warranty-repairs>

Warranty and Support:

Please email us at support@lifespanfitness.com.au for all warranty or support issues.

For all warranty or support related enquiries, an email must be sent before contacting us via other means.