

# PRO-FORM<sup>®</sup> XP 130

Model No. 831.28544.1

Serial No. \_\_\_\_\_

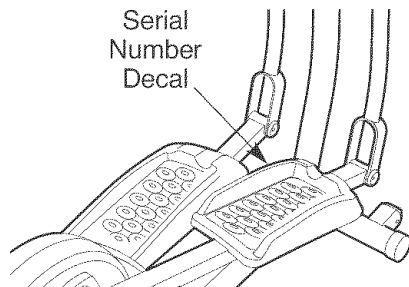

## ELLIPTICAL EXERCISER User's Manual

- Assembly
- Operation
- Maintenance
- Part List and Drawing

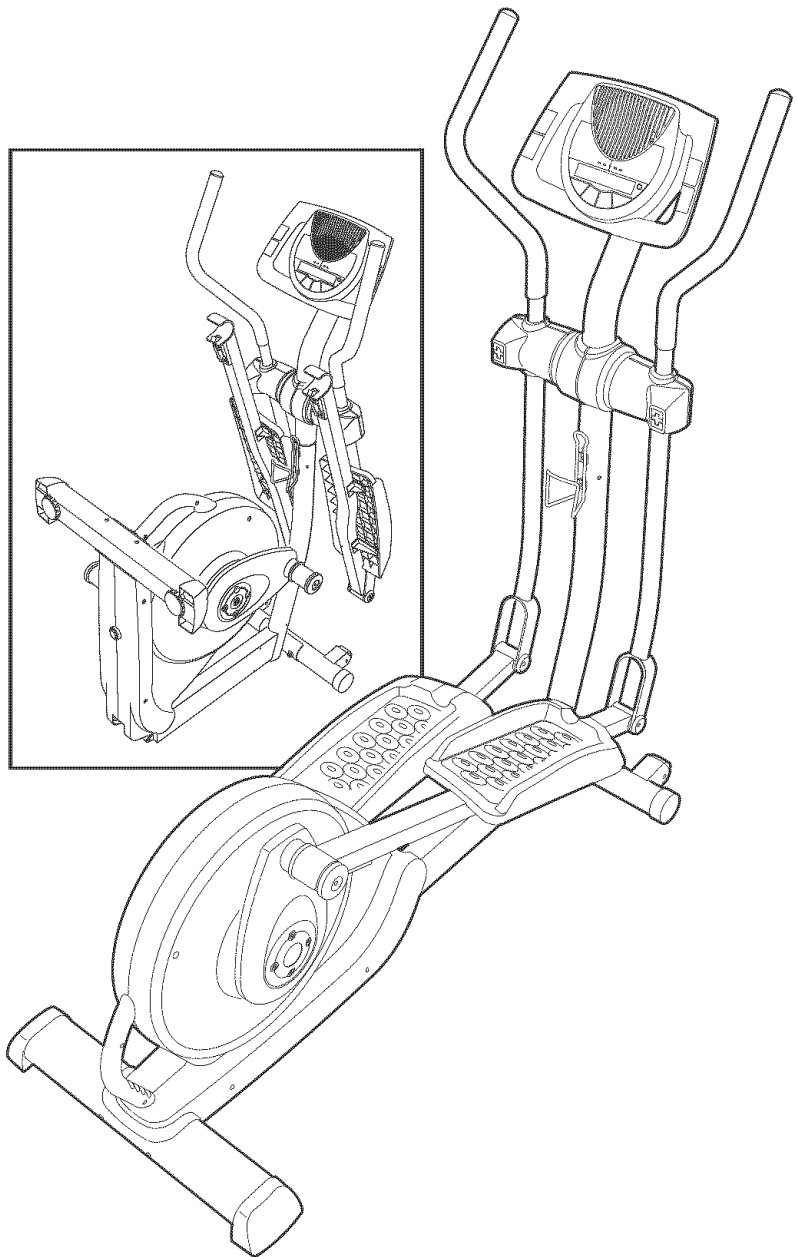

### **▲ CAUTION**

Read all precautions and instructions in this manual before using this equipment. Keep this manual for future reference.

Sears, Roebuck and Co., Hoffman Estates, IL 60179

# PRO-FORM<sup>®</sup> XP 130

---

## TABLE OF CONTENTS

IMPORTANT PRECAUTIONS .....	.3
BEFORE YOU BEGIN .....	.4
ASSEMBLY .....	.5
HOW TO USE THE ELLIPTICAL EXERCISER .....	.10
MAINTENANCE AND TROUBLESHOOTING .....	.23
CONDITIONING GUIDELINES .....	.24
PART LIST .....	.25
EXPLODED DRAWING .....	.26
HOW TO ORDER REPLACEMENT PARTS .....	.Back Cover
FULL 90 DAY WARRANTY .....	.Back Cover

# IMPORTANT PRECAUTIONS

**⚠ WARNING:** To reduce the risk of serious injury, read the following important precautions before using the elliptical exerciser.

1. Read all instructions in this manual and all warnings on the elliptical exerciser before using the elliptical exerciser. Use the elliptical exercise only as described in this manual.
2. It is the responsibility of the owner to ensure that all users of the elliptical exerciser are adequately informed of all precautions.
3. The elliptical exerciser is intended for home use only. Do not use the elliptical exerciser in a commercial, rental, or institutional setting.
4. Keep the elliptical exerciser indoors, away from moisture and dust. Place the elliptical exerciser on a level surface, with a mat beneath it to protect the floor or carpet. Make sure that there is enough clearance around the elliptical exerciser to mount, dismount, and use it.
5. Inspect and properly tighten all parts regularly. Replace any worn parts immediately.
6. Keep children under 12 and pets away from the elliptical exerciser at all times.
7. The elliptical exerciser should not be used by persons weighing more than 250 pounds.
8. Wear appropriate exercise clothes when using the elliptical exerciser. Always wear athletic shoes for foot protection while exercising.
9. Hold the handgrip pulse sensor or the handlebars when mounting, dismounting, or using the elliptical exerciser.
10. The pulse sensor is not a medical device. Various factors may affect the accuracy of heart rate readings. The pulse sensor is intended only as an exercise aid in determining heart rate trends in general.
11. Keep your back straight when using the elliptical exerciser; do not arch your back.
12. If you feel pain or dizziness while exercising, stop immediately and cool down.
13. When you stop exercising, allow the pedals to slowly come to a stop.
14. The decal shown below has been placed on the elliptical exerciser. If the decal is missing, or if it is not legible, please call toll-free 1-888-533-1333 and order a free replacement decal. Apply the decal in the location shown.

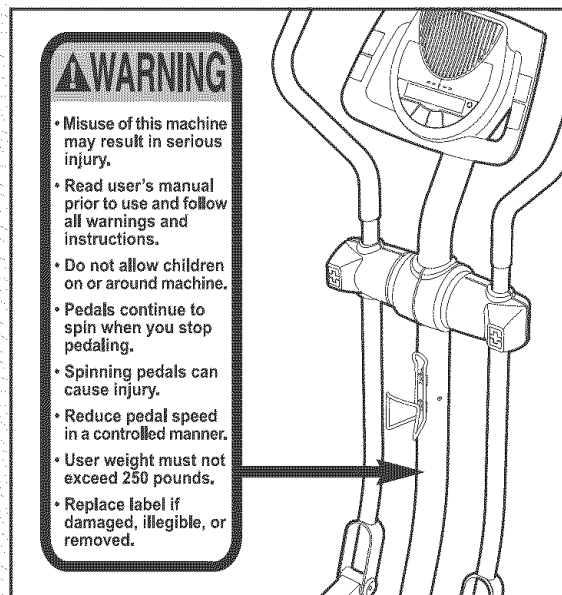

**⚠ WARNING:** Before beginning this or any exercise program, consult your physician. This is especially important for persons over the age of 35 or persons with pre-existing health problems. Read all instructions before using. Sears assumes no responsibility for personal injury or property damage sustained by or through the use of this product.

# BEFORE YOU BEGIN

Thank you for selecting the revolutionary PROFORM® XP 130 elliptical exerciser. The XP 130 elliptical exerciser provides a wide array of features designed to make your workouts at home more effective and enjoyable—and when you're not exercising, the unique XP 130 can be folded out of the way.



**For your benefit, read this manual carefully before you use the elliptical exerciser.** If you have questions after reading this manual, call 1-800-4-MY-

HOME® (1-800-469-4663). To help us assist you, please note the product model number and serial number before calling. The model number is 831.28544.1. The serial number can be found on a decal attached to the elliptical exerciser (see the front cover of this manual for the location of the decal).

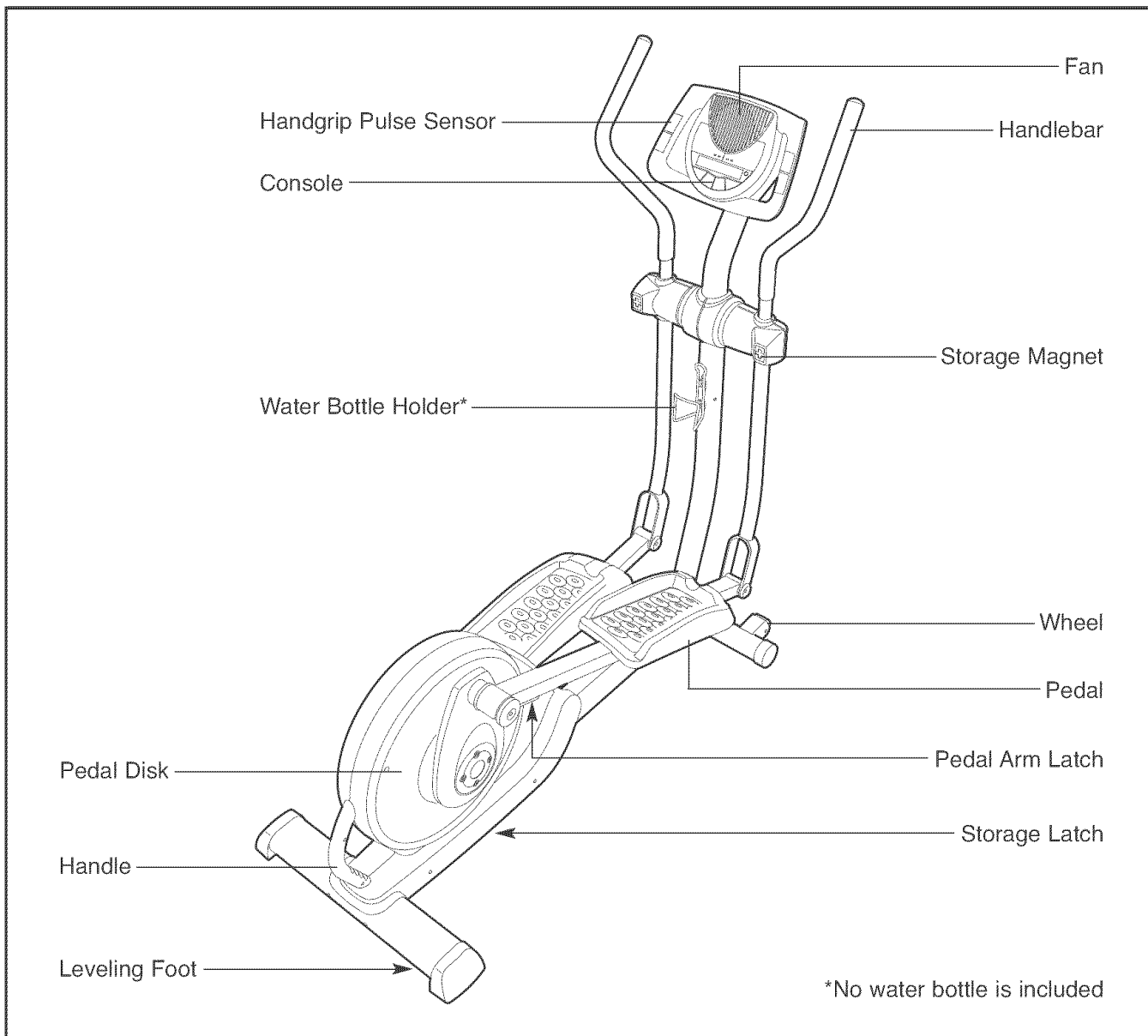
Before reading further, please familiarize yourself with the parts that are labeled in the drawing below.



# ASSEMBLY

**Assembly requires two persons.** Place all parts of the elliptical exerciser in a cleared area and remove the packing materials. Do not dispose of the packing materials until assembly is completed. **In addition to the included allen wrenches, assembly requires a phillips screwdriver** , **an adjustable wrench** , **and a rubber mallet** .

As you assemble the elliptical exerciser, use the drawings below to identify small parts. The number in parentheses below each drawing is the key number of the part, from the PART LIST on page 25. The second number is the quantity needed for assembly. **Note: Some small parts may have been pre-assembled. If a part is not in the parts bag, check to see if it has been pre-assembled. If a part is missing, call toll-free 1-888-533-1333.**

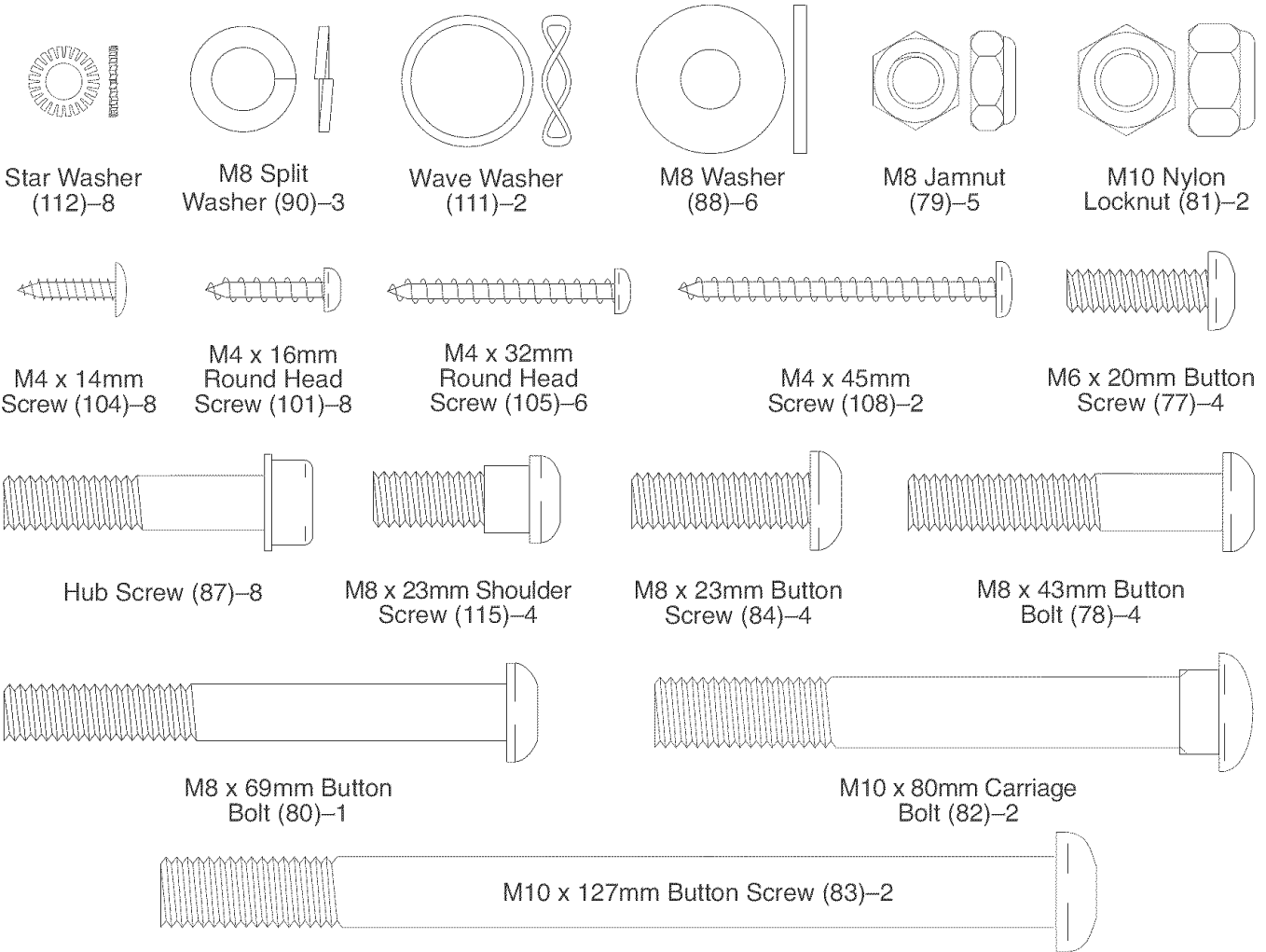

1. While another person lifts the Base (1), attach the Front Stabilizer (6) to the Base with two M10 x 80mm Carriage Bolts (82) and two M10 Nylon Locknuts (81).

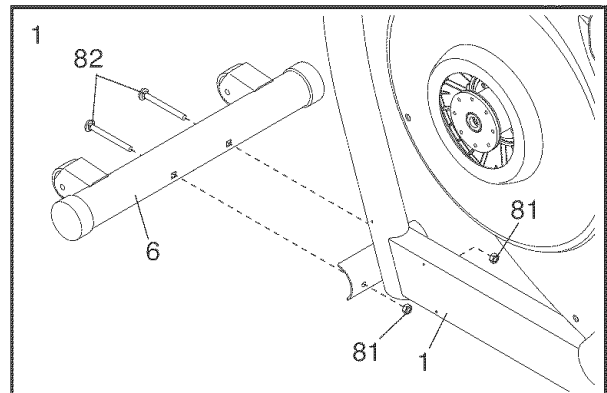

2. Remove the indicated screw and bracket from the Base (1). Discard the screw and the bracket.

Next, turn the Base Foot (26) into the Base (1) as far as possible.

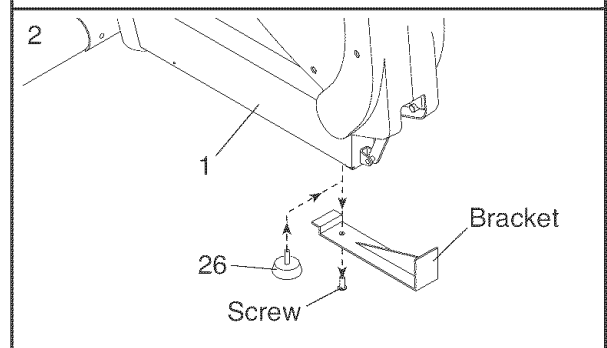

3. Attach the Rear Stabilizer (7) to the Frame (2) with two M10 x 127mm Button Screws (83).

Next, hold the handle on the Frame (2), press the Latch Button (68), and lower the Frame until the Rear Stabilizer (7) is resting on the floor.

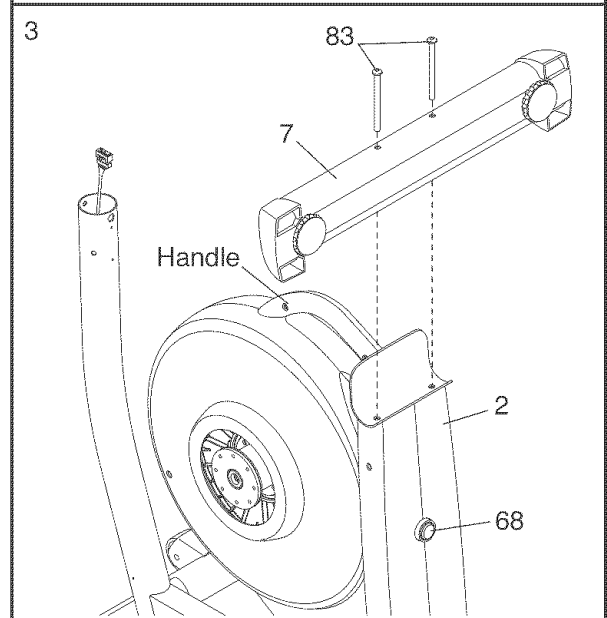

4. Hold a Hub Cover (75) and a Crank Arm (36) against the left Crank Hub (38). Align the holes in the Hub Cover and the Crank Arm with the unused holes in the left Crank Hub. Next, insert four Hub Screws (87) into the Hub Cover and the Crank Arm, and finger tighten the Hub Screws into the left Crank Hub. Tighten one of the Hub Screws, and then tighten the Hub Screw across from the first Hub Screw. Then, tighten the remaining two Hub Screws.

Repeat this step on the other side of the elliptical exerciser; **make sure that the Crank Arms (36) are oriented so the Crank Bushing Sleeves (43) are in the positions shown.**

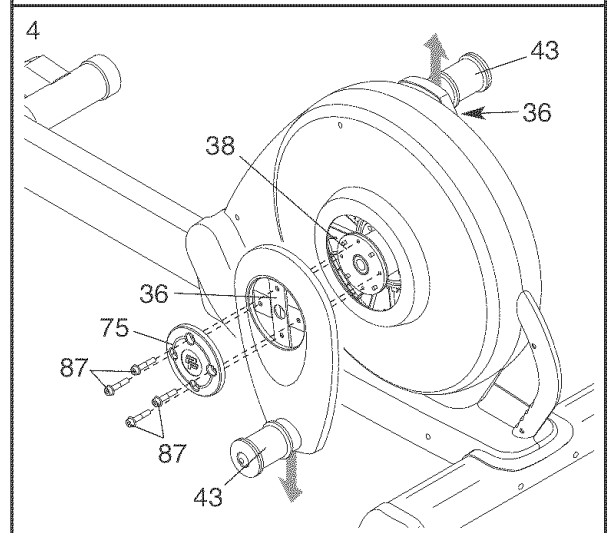

- While another person holds the Upright (3), connect the Upper Wire Harness (48) to the Lower Wire Harness (49). **Gently pull the upper end of the Upper Wire Harness to remove any slack**, and insert the Upright into the Base (1). Attach the Upright with an M8 x 69mm Button Bolt (80), an M8 Split Washer (90), and an M8 Jamnut (79). **Do not tighten the Button Bolt yet; make sure that the Jamnut is in the hexagonal hole in the Base.**

Next, finger tighten two M8 x 23mm Button Screws (84) with M8 Split Washers (90) into the Base (1). **Do not tighten the Button Screws yet.**

Attach the Water Bottle Holder (22) to the Base (1) with two M4 x 14mm Screws (104).

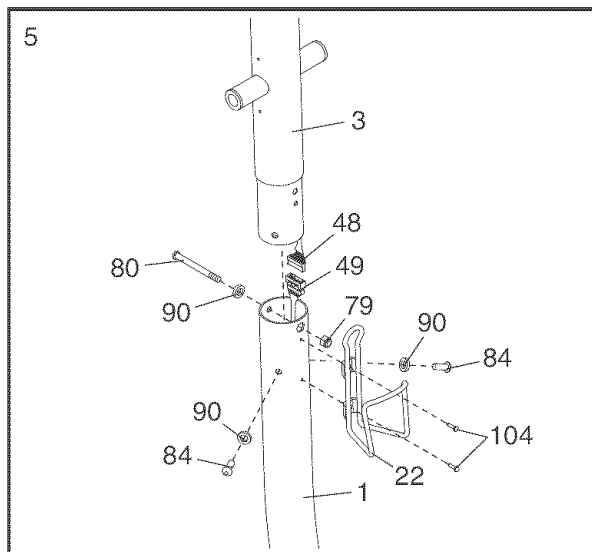

- Insert the end of the Upper Wire Harness (48) through the rectangular hole in the Console Bracket (4). Attach the Console Bracket to the Upright (3) with four M6 x 20mm Button Screws (77).

Orient one of the Upright Covers (17) as shown, and hold it against the Upright (3). Attach the Upright Cover with two M4 x 16mm Round Head Screws (101). Attach the other Upright Cover in the same way.

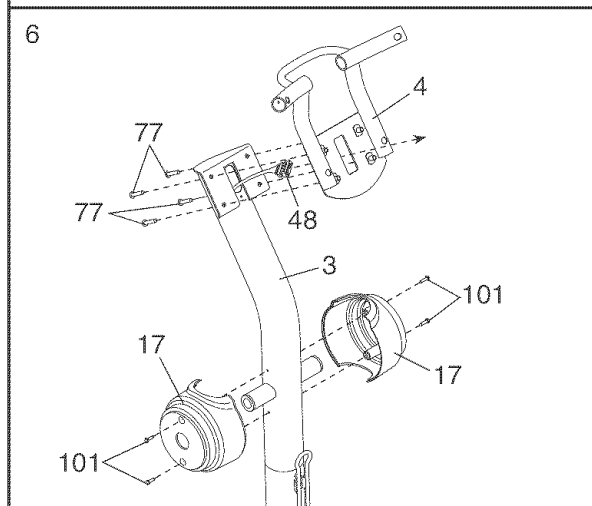

- The Console (5) requires four 1.5V "D" batteries (not included); alkaline batteries are recommended. Press the two tabs on the battery cover, and remove the battery cover. Next, insert four batteries into the Console. **Make sure that the batteries are oriented as shown by the diagrams inside of the battery compartments.** Then, reattach the battery cover to the Console.

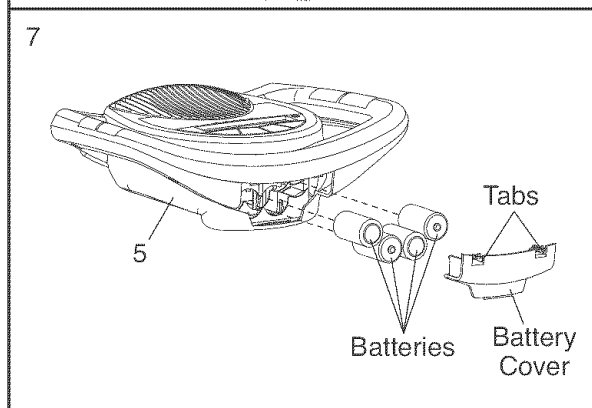

- While another person holds the Console (5) near the Console Bracket (4), connect the wire harness on the Console to the Upper Wire Harness (48). Insert the excess wire harness into the Upright (3). Next, attach the Console to the Console Bracket with four M4 x 16mm Round Head Screws (101). **Be careful to avoid pinching the wire harness.**

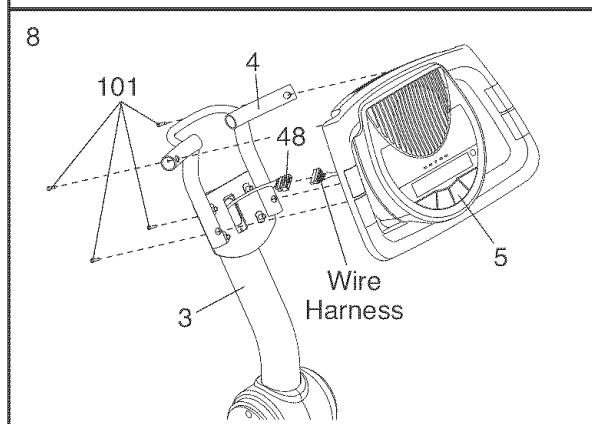

9. Identify the Left Handlebar (8) and the Left Upper Body Arm (11), which are marked with stickers.

Orient the Left Handlebar (8) and the Left Upper Body Arm (11) as shown, and insert the Left Handlebar into the Left Upper Body Arm. Attach the Left Handlebar with two M8 x 43mm Button Bolts (78) and two M8 Jamnuts (79). **Make sure that the Jamnuts are in the hexagonal holes in the Left Upper Body Arm.**

Attach the Right Handlebar (9) to the Right Upper Body Arm (12) in the same way.

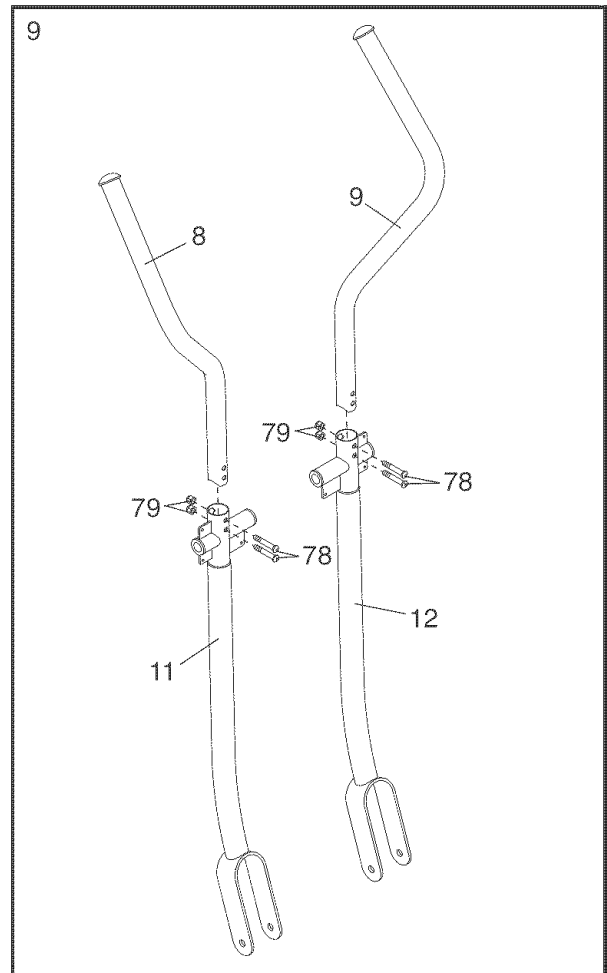

10. Insert the Pivot Axle (74) into the Upright (3) and center it. Apply a generous amount of the included grease to the Pivot Axle.

Orient the Left Upper Body Arm (11) as shown, and slide it onto the left end of the Pivot Axle (74). Slide the Right Upper Body Arm (12) onto the right end of the Pivot Axle.

Tighten an M8 x 23mm Button Screw (84) with an M8 Washer (88) and a Wave Washer (111) into each end of the Pivot Axle (74). **Make sure that the Wave Washers are on the ends of the Pivot Axle.**

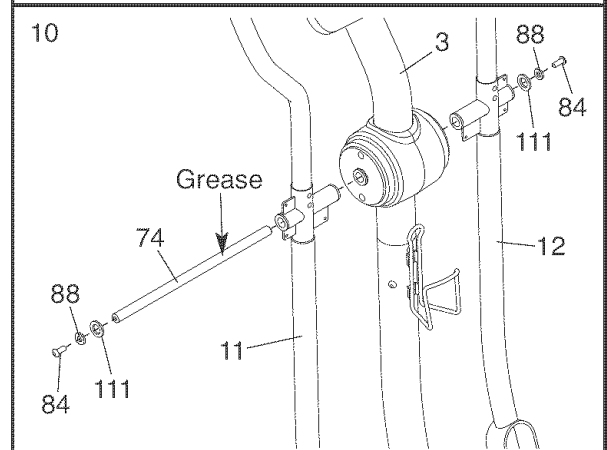

11. Hold the Left Front Handlebar Cover (18) and the Left Rear Handlebar Cover (19) around the Left Upper Body Arm (11). Attach the Handlebar Covers with three M4 x 32mm Round Head Screws (105).

Attach the Right Front Handlebar Cover (20) and the Right Rear Handlebar Cover (21) in the same way.

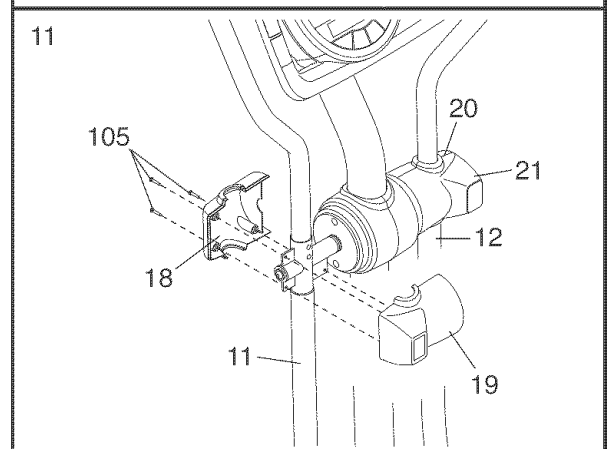

12. Identify the Left Pedal (13) and the Left Pedal Leg (14), which are marked with stickers.

Attach the Left Pedal (13) to the Left Pedal Leg (14) with an M4 x 45mm Screw (108), three M4 x 14mm Screws (104), and four Star Washers (112).

Attach the Right Pedal (not shown) to the Right Pedal Leg (not shown) in the same way.

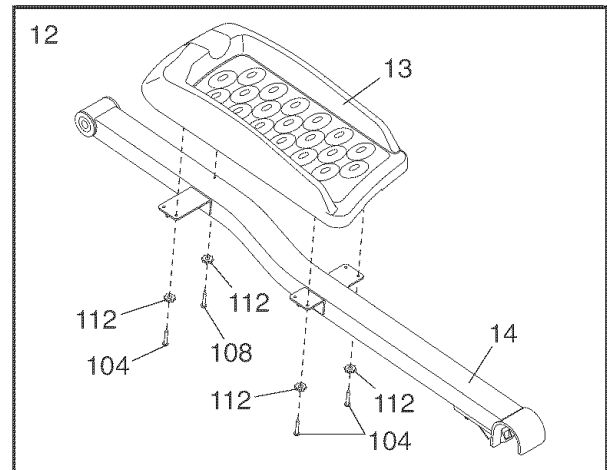

13. Apply a thin film of grease to one of the Pedal Leg Axles (32) and to the faces of the two Pedal Leg Bushings (33) in the Left Pedal Leg (14).

Next, slide an M8 Washer (88) and a Pedal Leg Cover (31) onto an M8 x 23mm Shoulder Screw (115), and turn the Shoulder Screw a few turns into the Pedal Leg Axle (32).

While another person holds the front end of the Left Pedal Leg (14) inside of the bracket on the Left Upper Body Arm (11), insert the Pedal Leg Axle (32) into both parts. Next, slide an M8 Washer (88) and a Pedal Leg Cover (31) onto another M8 x 23mm Shoulder Screw (115), and turn the Shoulder Screw a few turns into the Pedal Leg Axle. Tighten both Shoulder Screws.

Repeat this step on the other side of the elliptical exerciser.

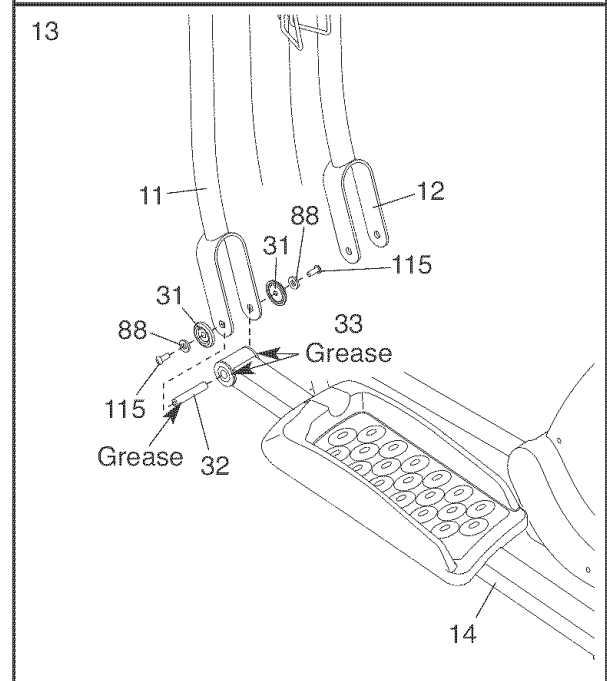

14. Lift the latch on the underside of the Left Pedal Leg (14), and set the Left Pedal Leg on the left Crank Bushing Sleeve (43). Release the lever, and make sure that the Left Pedal Leg is securely connected to the Crank Bushing Sleeve.

Connect the Right Pedal Leg (not shown) in the same way.

See step 5. Tighten the M8 x 69mm Button Bolt (80) and the two M8 x 23mm Button Screws (84).

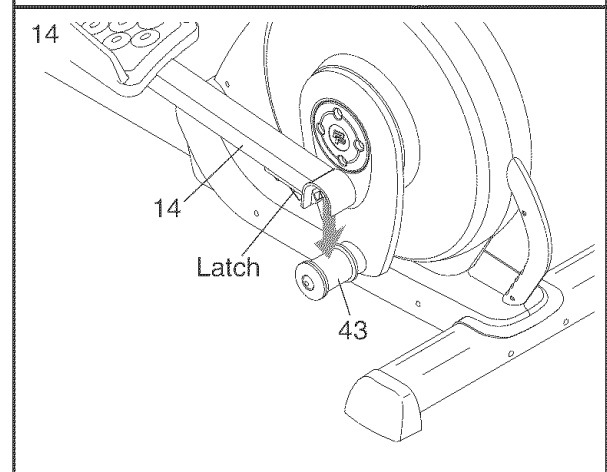

15. **Make sure that all parts of the elliptical exerciser are properly tightened.** Note: Some hardware may be left over after assembly is completed. To protect the floor or carpet from damage, place a mat under the elliptical exerciser.

# HOW TO USE THE ELLIPTICAL EXERCISER

## HOW TO FOLD AND UNFOLD THE ELLIPTICAL EXERCISER

When the elliptical exerciser is not in use, the frame can be folded out of the way. First, lift the latch under each pedal leg, and lift the pedal legs off the sleeves on the crank arms.

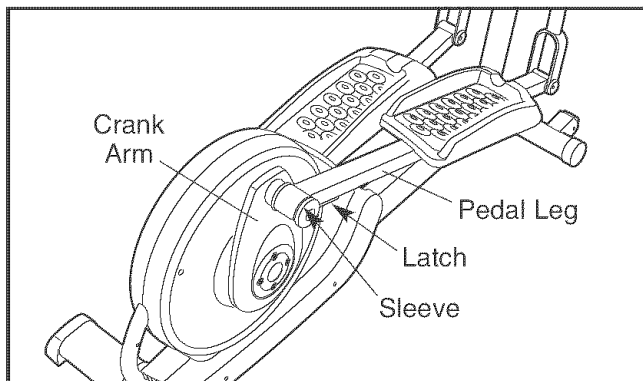

Next, raise the pedal legs until they touch the magnets on the upper body arms; the magnets will hold the pedal legs in place. Then, hold the handle and lift the frame until it locks in a vertical position.

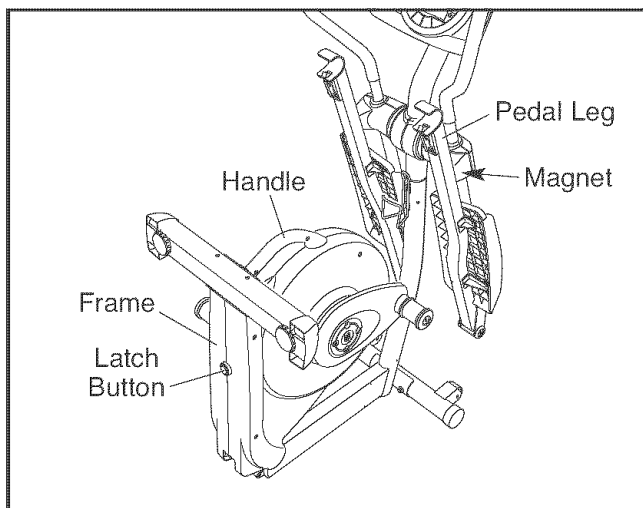

To use the elliptical exerciser, first hold the handle, press the latch button, and lower the frame.

Next, pull the pedal legs off the magnets on the upper body arms. Then, **lift the latches under the pedal legs**, and set the pedal legs on the sleeves on the crank arms. Release the latches, and make sure that the pedal legs are securely connected to the crank arms.

## HOW TO MOVE THE ELLIPTICAL EXERCISER

To move the elliptical exerciser, first fold it as described at the left. Next, stand in front of the elliptical exerciser, hold the handle on the console bracket, and place one foot against the center of the front stabilizer. Pull the handle until the elliptical exerciser will roll on the front wheels. Carefully move the elliptical exerciser to the desired position, and then lower it.

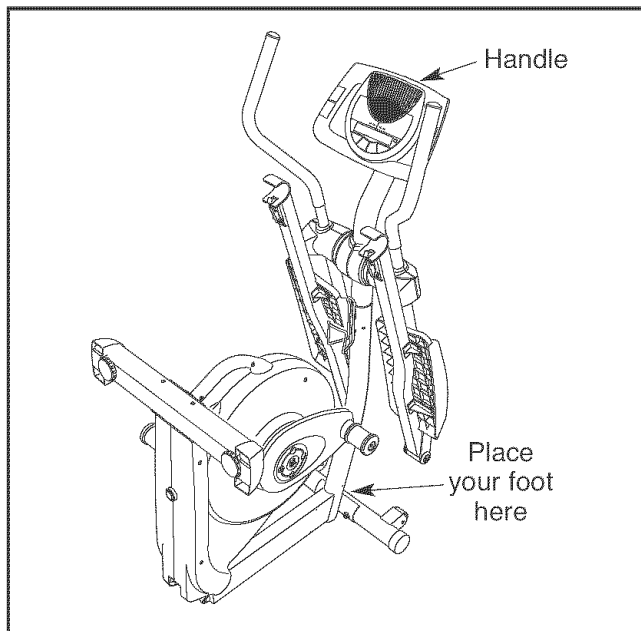

## HOW TO LEVEL THE ELLIPTICAL EXERCISER

If the elliptical exerciser rocks slightly on your floor during use, turn one or both of the leveling feet beneath the rear stabilizer until the rocking motion is eliminated.

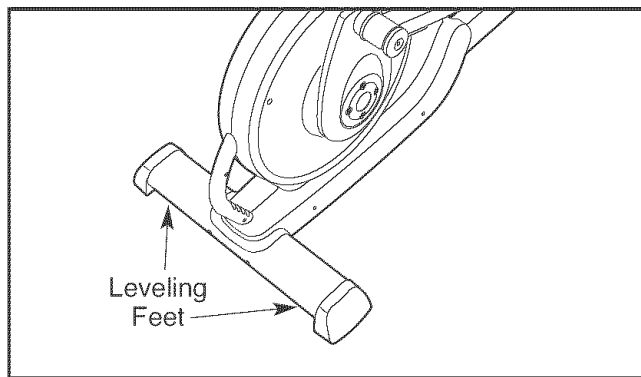

## HOW TO EXERCISE ON THE ELLIPTICAL EXERCISER

To mount the elliptical exerciser, hold the handlebars and step onto the pedal that is in the lowest position. Next, step onto the other pedal. Push the pedals until they begin to move with a continuous motion.

**Note: The crank arms can turn in either direction. It is recommended that you turn the crank arms in the direction shown by the arrow at the right; however, for variety, you can turn the crank arms in the opposite direction.**

To dismount the elliptical exerciser, wait until the pedals come to a complete stop. **Note: The elliptical exerciser does not have a free wheel; the pedals will continue to move until the flywheel stops.** When the pedals are stationary, step off the highest pedal first. Then, step off the lowest pedal.

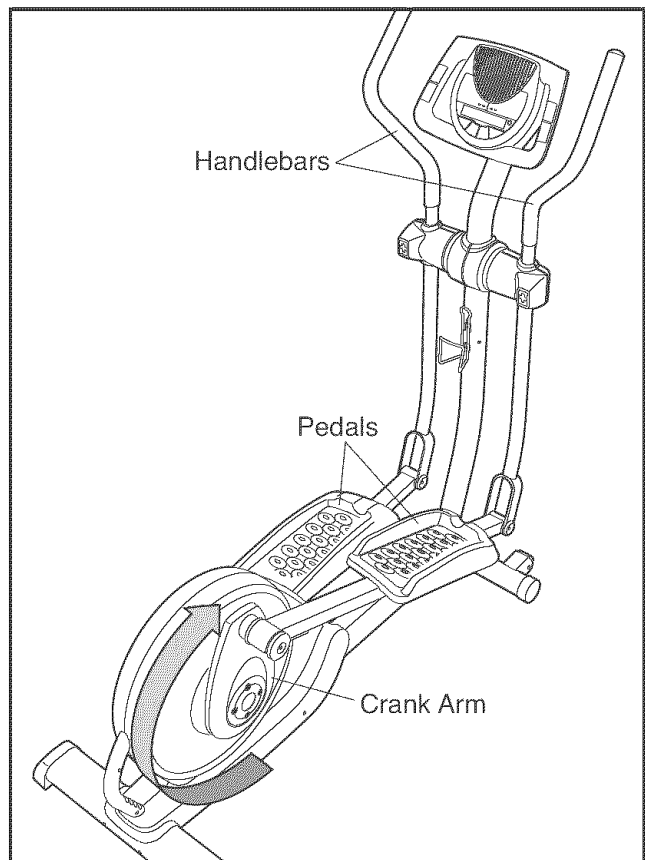

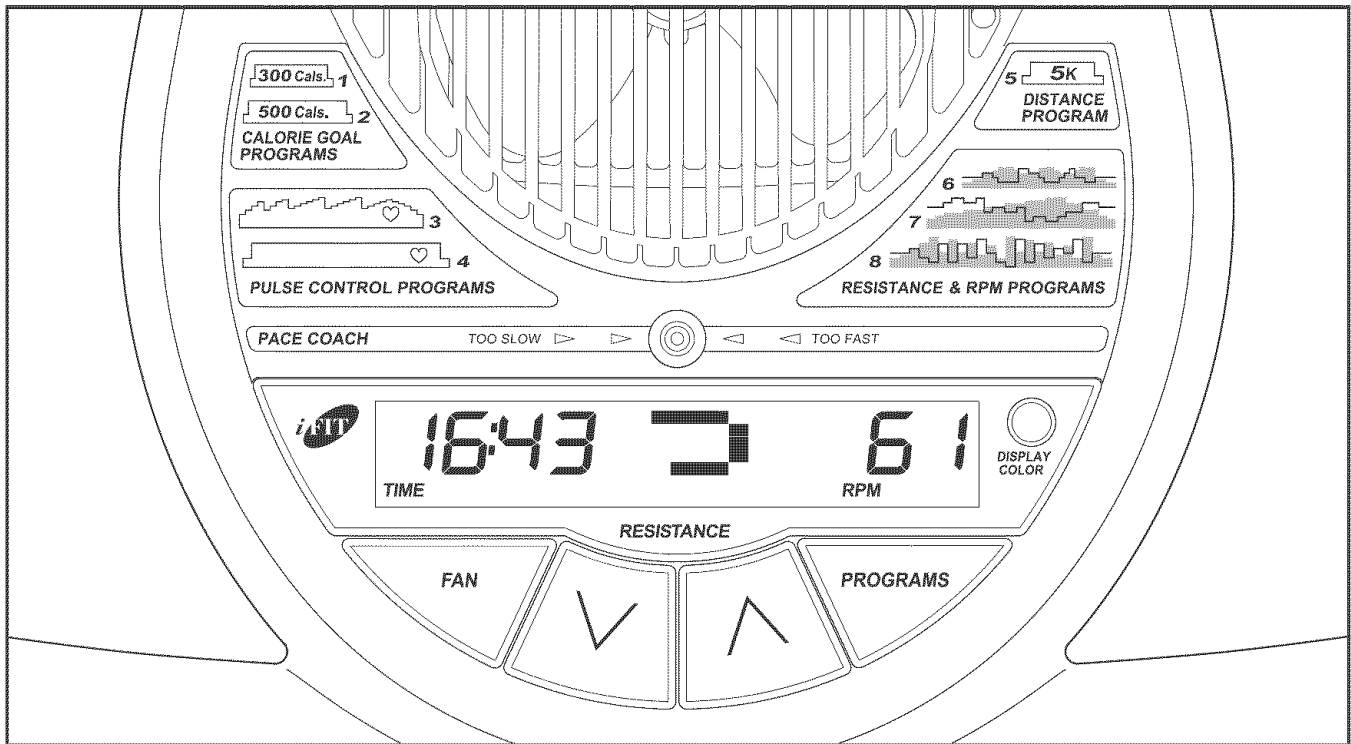

## FEATURES OF THE CONSOLE

The advanced console offers an array of features designed to make your workouts more effective and enjoyable. When the manual mode of the console is selected, you can change the resistance of the pedals with the touch of a button. As you exercise, the console will provide continuous exercise feedback. You can even monitor your heart rate using the handgrip pulse sensor.

The console also offers a selection of preset programs. The two calorie goal programs allow you to choose a calorie-burning goal for your workout. As you exercise, the console will count the calories that you burn until the goal is reached.

The two pulse control programs automatically control the resistance of the pedals and prompt you to increase or decrease your pedaling pace to keep your heart rate near a target heart rate setting during your workout.

The distance program counts the number of revolutions that you pedal during your workout, until you have completed 5,000 revolutions.

The three resistance & rpm programs automatically change the resistance of the pedals and prompt you to vary your pedaling pace as they guide you through an effective workout.

The console also features iFIT.com interactive technology. Having iFIT.com technology is like having a personal trainer in your home. Using a stereo audio cable (available at electronics stores), you can connect the elliptical exerciser to your portable stereo, home stereo, computer, or VCR and play special iFIT.com CD and video programs (iFIT.com CDs and videocassettes are available separately). iFIT.com programs automatically control the resistance of the pedals and prompt you to vary your pace as a personal trainer coaches you through every step of your workout. High-energy music provides added motivation. **To purchase iFIT.com CDs and videocassettes, call the toll-free telephone number on the front cover of this manual.**

With the elliptical exerciser connected to your computer, you can also go to our Web site at [www.iFIT.com](http://www.iFIT.com) and access programs directly from the internet. **Explore [www.iFIT.com](http://www.iFIT.com) for more information.**

To use the manual mode of the console, follow the steps beginning on page 13. To use a calorie goal program, see page 15. To use a pulse control program, see page 15. To use the distance program, see page 17. To use a resistance & rpm program, see page 17. To use an iFIT.com CD or video program, see page 21. To use an iFIT.com program directly from our Web site, see page 22.

Note: If there is a sheet of clear plastic on the face of the console, remove the plastic.

## HOW TO USE THE MANUAL MODE

- 1 Press the Resistance decrease button or begin pedaling to turn on the console.

A moment after the console is turned on, the display will light.

- 2 Select the manual mode.

Each time the console is turned on, the manual mode will be selected automatically. If you have selected a program or the iFIT.com mode, select the manual mode by pressing the Programs button repeatedly until the display appears as shown below.

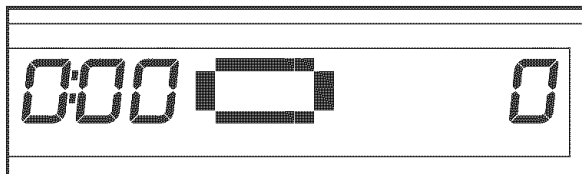

- 3 Begin pedaling and change the resistance of the pedals as desired.

As you pedal, change the resistance of the pedals by pressing the Resistance increase and decrease buttons repeatedly. There are ten resistance levels. Note: After the buttons are pressed, it will take a moment for the pedals to reach the selected resistance level.

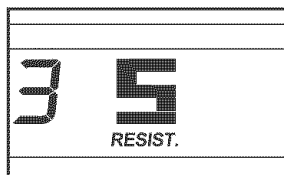

- 4 Monitor your progress with the display.

Note: The display can be backlit with any of three colors, or the backlighting can be turned off to

conserve the batteries. Press the Display Color button repeatedly to select a color or to turn off the backlighting.

**The left side of the display**—The left side of the display will show the elapsed time, the approximate number of calories you have burned, and the approximate number of grams of carbs you have burned. Note: When some preset programs are selected, the display will show the time remaining in the program instead of the elapsed time. When a calorie goal program is selected, the display will show the number of calories still to be burned instead of the number of calories you have burned.

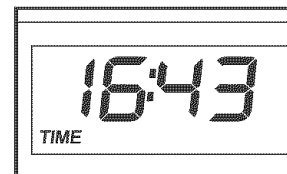

The left side of the display will also show your heart rate when you use the handgrip pulse sensor (see step 5 on page 14).

**The center of the display**—When the manual mode, a calorie goal program, the distance program, or the iFIT.com mode is selected, the center of the display will show a track that represents 640 revolutions. As you exercise, the indicators around the track will appear in succession until the entire track appears. The track will then disappear and the indicators will again begin to appear in succession.

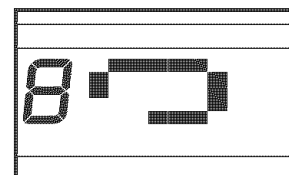

The center of the display will also show the resistance setting of the pedals for a few seconds each time the resistance setting changes.

**The right side of the display**—The right side of the display will show the distance (total revolutions) you have pedaled and your pedaling pace (revolutions per minute [rpm]). Note: When the distance program is selected, the display will show the number of revolutions still to be pedaled instead of the number of revolutions you have pedaled.

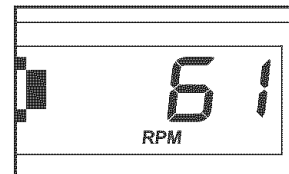

**5 Measure your heart rate if desired.**

If there are thin sheets of plastic on the metal contacts on the handgrip pulse sensor, peel off the plastic. To measure your heart rate, hold the handgrip pulse sensor, with your palms resting against the metal contacts. **Avoid moving your hands or gripping the contacts too tightly.**

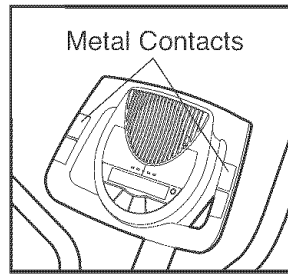

When your pulse is detected, a heart-shaped symbol will flash in the left side of the display each time your heart beats, one or two dashes will appear, and then your heart rate will be shown. For the most accurate heart rate reading, hold the contacts for at least 15 seconds. Note: If you continue to hold the handgrip pulse sensor, the display will show your heart rate for up to 30 seconds. The display will then show your heart rate along with the other modes.



If your heart rate is not shown, make sure that your hands are positioned as described. Be care-

ful not to move your hands excessively or to squeeze the metal contacts too tightly. For optimal performance, clean the metal contacts using a soft cloth; **never use alcohol, abrasives, or chemicals.**

**6 Turn on the fan if desired.**

To turn on the fan at low speed, press the Fan button. To turn on the fan at high speed, press the button a second time. To turn off the fan, press the button a third time. Note: If the pedals are not moved for a few minutes, the fan will automatically turn off to conserve the batteries.

Pivot the thumb tab on the right side of the fan to adjust the angle of the fan.

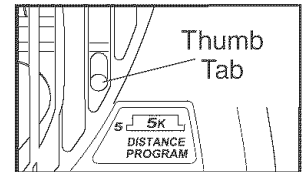

**7 When you are finished exercising, the console will automatically turn off.**

If the pedals are not moved for several seconds, a tone will sound and the console will pause.

If the pedals are not moved for about five minutes, the console will turn off and the display will be reset.

## HOW TO USE A CALORIE GOAL PROGRAM

- 1 Press the Resistance decrease button or begin pedaling to turn on the console.

A moment after the console is turned on, the display will light.

- 2 Select one of the calorie goal programs.

Press the Programs button repeatedly until "P 1" or "P 2" and a goal of 300 calories or 500 calories appear in the display.

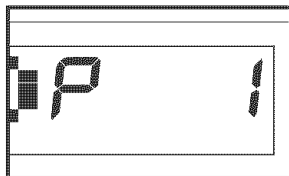

- 3 Begin pedaling to start the program.

When a calorie goal program is used, the console will function in the same way as when the manual mode is selected, except the left side of the display will show the number of calories still to be burned instead of the number of calories you have burned. When the calorie goal is reached, a tone will sound and the time will stop incrementing in the display.

- 4 When you are finished exercising, the console will automatically turn off.

See step 7 on page 14.

## HOW TO USE A PULSE CONTROL PROGRAM

- 1 Press the Resistance decrease button or begin pedaling to turn on the console.

A moment after the console is turned on, the display will light.

- 2 Select one of the pulse control programs.

Press the Programs button repeatedly until "P 3" or "P 4" appears in the right side of the display.

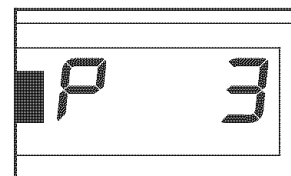

If pulse control program 3 is selected, a profile of the target heart rate settings of the program will scroll across the center of the display.

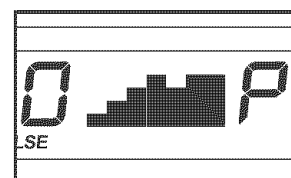

If pulse control program 4 is selected, a pulse symbol will appear in the center of the display. Each time a heartbeat is detected while you are using the handgrip pulse sensor, the pulse symbol will reappear.

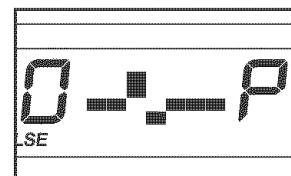

- 3 Enter a target heart rate setting.

If pulse control program 3 is selected, the maximum target heart rate setting of the program will flash in the display. If desired, press the Resistance increase and decrease buttons to change the maximum target heart rate setting (see **EXERCISE INTENSITY** on page 24). If you change the maximum target heart rate setting, the intensity level of the entire program will change.

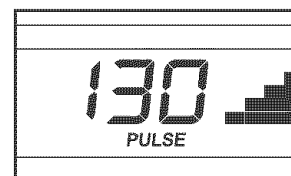

If pulse control program 4 is selected, the target heart rate setting for the program will flash in the display. If desired, press the Resistance increase and decrease buttons to change the target heart rate setting (see **EXERCISE INTENSITY** on page 24).

#### 4 Hold the handgrip pulse sensor.

It is not necessary to hold the handgrip pulse sensor continuously during a pulse control program; however, you should hold the handgrip pulse sensor frequently for the program to operate properly. **Each time you hold the handgrip pulse sensor, keep your hands on the metal contacts for at least 30 seconds.**

#### 5 Begin pedaling to start the program.

**Pulse control program 3** is divided into 30 one-minute segments. One target heart rate setting is programmed for each segment. Note: The same target heart rate setting may be programmed for two or more consecutive segments.

The target heart rate setting for the first segment will be shown in the flashing Current Segment column in the center of the display. The target heart rate settings for the next four segments will be shown in the columns to the right.

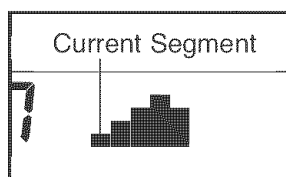

When only three seconds remain in the first segment of the program, both the Current Segment column and the column to the right will flash, a series of tones will sound, and *all target heart rate settings will move one column to the left*. The target heart rate setting for the second segment will then be shown in the flashing Current Segment column.

**Pulse control program 4** is divided into 40 one-minute segments. The same target heart rate setting is programmed for all segments. Note: For a shorter workout, stop exercising or select a different program before the program ends.

**During both pulse control programs**, the console will regularly compare your heart rate to the target heart rate setting. If your heart rate is too far below or above the target heart rate setting, the resistance of the pedals will automatically increase or decrease to bring your heart rate closer to the target heart rate setting.

After the first minute of the program, the Pace Coach will prompt you to maintain a consistent pedaling pace. When one of the “Too Slow” arrows lights, increase your pace. When the one of the “Too Fast” arrows lights, decrease your pace. When the center indicator lights, maintain your current pace.

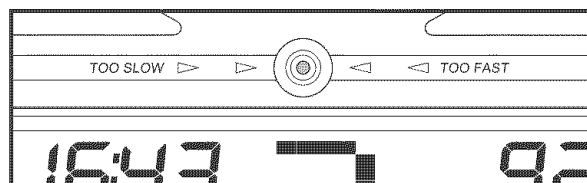

**Important: The target heart rate settings are intended only to provide motivation. Your actual heart rate may be slower than the target heart rate settings. Make sure to exercise at a pace that is comfortable for you.**

Note: During the program, you can manually override the resistance setting for the current segment, if desired, by pressing the increase and decrease buttons. However, when the console compares your heart rate to the target heart rate setting, the resistance of the pedals may automatically increase or decrease to bring your heart rate closer to the target heart rate setting.

If you stop pedaling for several seconds, a tone will sound and the program will pause. To restart the program, simply resume pedaling.

#### 6 Monitor your progress with the display.

See step 4 on page 13.

#### 7 Turn on the fan if desired.

See step 6 on page 14.

#### 8 When you are finished exercising, the console will automatically turn off.

See step 7 on page 14.

## HOW TO USE THE DISTANCE PROGRAM

- 1 Press the Resistance decrease button or begin pedaling to turn on the console.

A moment after the console is turned on, the display will light.

- 2 Select the distance program.

Press the Programs button repeatedly until "P 5" and a goal of 5,000 revolutions appear in the display.

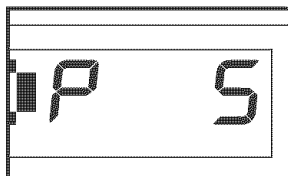

- 3 Begin pedaling to start the program.

When the distance program is used, the console will function in the same way as when the manual mode is selected, except the right side of the display will show the number of revolutions still to be pedaled instead of the number of revolutions you have pedaled. When the calorie goal is reached, a tone will sound and the time will stop incrementing in the display.

- 4 When you are finished exercising, the console will automatically turn off.

See step 7 on page 14.

## HOW TO USE A RESISTANCE & RPM PROGRAM

- 1 Press the Resistance decrease button or begin pedaling to turn on the console.

A moment after the console is turned on, the display will light.

- 2 Select one of the resistance & rpm programs.

Press the Programs button repeatedly until "P 6," "P 7," or "P 8" appears in the right side of the display. When a resistance & rpm program is selected, a profile of the resistance settings of the program will scroll across the center of the display. The left side of the display will show how long the program will last.

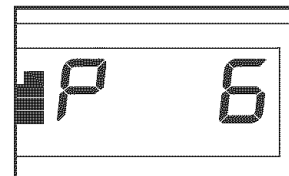

- 3 Begin pedaling to start the program.

Each program is divided into several one-minute segments. One resistance setting and one pace setting are programmed for each segment. Note: The same resistance setting and/or pace setting may be programmed for two or more consecutive segments.

The resistance setting for the first segment will be shown in the flashing Current Segment column in the center of the display. (Note: The pace settings are not shown in the display.) The resistance settings for the next four segments will be shown in the columns to the right.

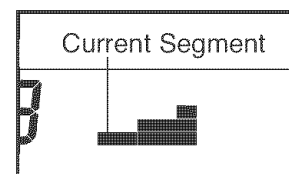

As you exercise, the Pace Coach will help you to keep your pedaling pace near the pace setting for the current segment. When one of the "Too Slow" arrows lights, increase your pace. When the one of the "Too Fast" arrows lights, decrease your pace. When the center indicator lights, maintain your current pace.

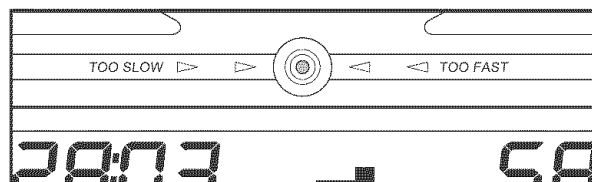

**Important: The pace settings are intended only to provide motivation. Your actual pace may be slower than the pace settings. Make sure to exercise at a pace that is comfortable for you.**

When only three seconds remain in the first segment of the program, both the Current Segment column and the column to the right will flash, a series of tones will sound, and *all resistance settings will move one column to the left*. The resistance setting for the second segment will then be shown in the flashing Current Segment column, and the resistance of the pedals will change to the resistance setting for the second segment. Note: If all of the indicators in the Current Segment column are lit after the resistance settings have moved to the left, *the resistance settings may move downward* so only the highest indicators appear in the matrix.

The program will continue until the resistance setting for the last segment is shown in the Current Segment column and the last segment ends.

Note: During the program, you can override the resistance setting for the current segment, if

desired, by pressing the increase or decrease button. However, when the next segment begins, the resistance will change if a different resistance setting is programmed for the next segment.

If you stop pedaling for several seconds, a tone will sound and the program will pause. To restart the program, simply resume pedaling.

**4 Monitor your progress with the display.**

See step 4 on page 13.

**5 Measure your heart rate if desired.**

See step 5 on page 14.

**6 Turn on the fan if desired.**

See step 6 on page 14.

**7 When you are finished exercising, the console will automatically turn off.**

See step 7 on page 14.

## HOW TO CONNECT YOUR CD PLAYER, VCR, OR COMPUTER

To use iFIT.com CDs, the elliptical exerciser must be connected to your portable CD player, portable stereo, home stereo, or computer with CD player. See pages 19 and 20 for connecting instructions. To use iFIT.com videocassettes, the elliptical exerciser must be connected to your VCR. See page 21 for connecting instructions. To use iFIT.com programs directly from our Web site, the elliptical exerciser must be connected to your computer. See page 20.

## HOW TO CONNECT YOUR PORTABLE CD PLAYER

Note: If your CD player has separate LINE OUT and PHONES jacks, see instruction A below. If your CD player has only one jack, see instruction B.

- A. Plug one end of a 1/8" to 1/8" stereo audio cable (available at electronics stores) into the jack beneath the console. Plug the other end of the cable into the LINE OUT jack on your CD player. Plug your headphones into the PHONES jack.

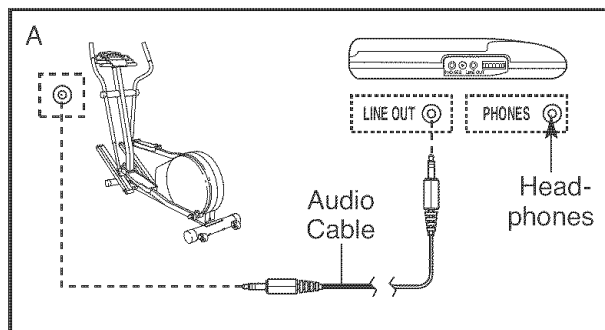

- B. Plug one end of a 1/8" to 1/8" stereo audio cable (available at electronics stores) into the jack beneath the console. Plug the other end of the cable into a 1/8" Y-adaptor (available at electronics stores). Plug the Y-adaptor into the PHONES jack on your CD player. Plug your headphones into the other side of the Y-adaptor.

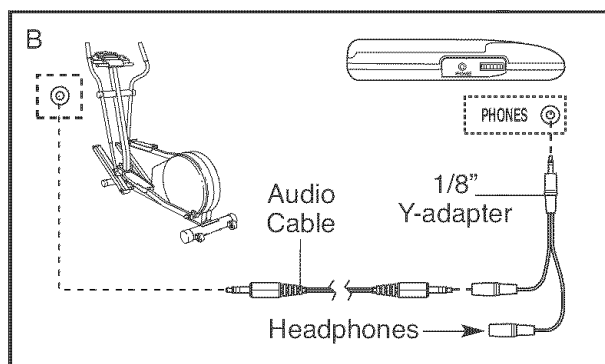

## HOW TO CONNECT YOUR PORTABLE STEREO

Note: If your stereo has an RCA-type AUDIO OUT jack, see instruction A below. If your stereo has a 1/8" LINE OUT jack, see instruction B. If your stereo has only a PHONES jack, see instruction C.

- A. Plug one end of a 1/8" to RCA stereo audio cable (available at electronics stores) into the jack beneath the console. Plug the other end of the cable into the AUDIO OUT jack on your stereo.

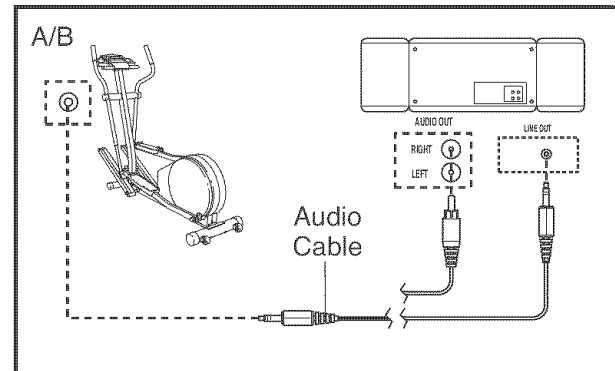

- B. See the drawing above. Plug one end of a 1/8" to 1/8" stereo audio cable (available at electronics stores) into the jack beneath the console. Plug the other end of the cable into the LINE OUT jack on your stereo.

- C. Plug one end of a 1/8" to 1/8" stereo audio cable (available at electronics stores) into the jack beneath the console. Plug the other end of the cable into a 1/8" Y-adaptor (available at electronics stores). Plug the Y-adaptor into the PHONES jack on your stereo. Plug your headphones into the other side of the Y-adaptor.

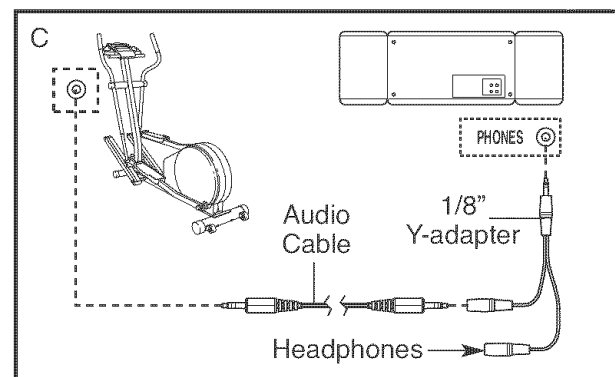

## HOW TO CONNECT YOUR HOME STEREO

**Note:** If your stereo has an unused LINE OUT jack, see instruction A below. If the LINE OUT jack is being used, see instruction B.

- A. Plug one end of a 1/8" to RCA stereo audio cable (available at electronics stores) into the jack beneath the console. Plug the other end of the cable into the LINE OUT jack on your stereo.

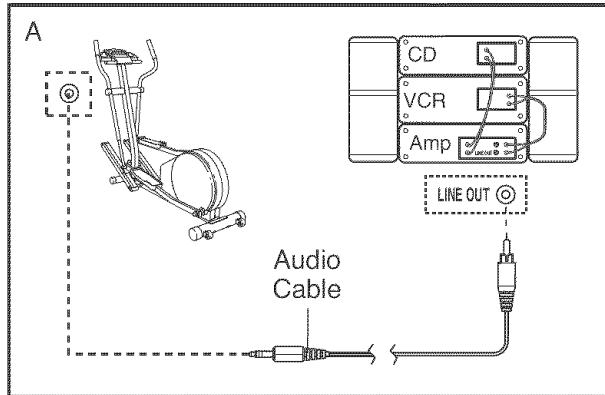

- B. Plug one end of a 1/8" to RCA stereo audio cable (available at electronics stores) into the jack beneath the console. Plug the other end of the cable into an RCA Y-adapter (available at electronics stores). Next, remove the wire that is currently plugged into the LINE OUT jack on your stereo and plug the wire into the unused side of the Y-adapter. Plug the Y-adapter into the LINE OUT jack on your stereo.

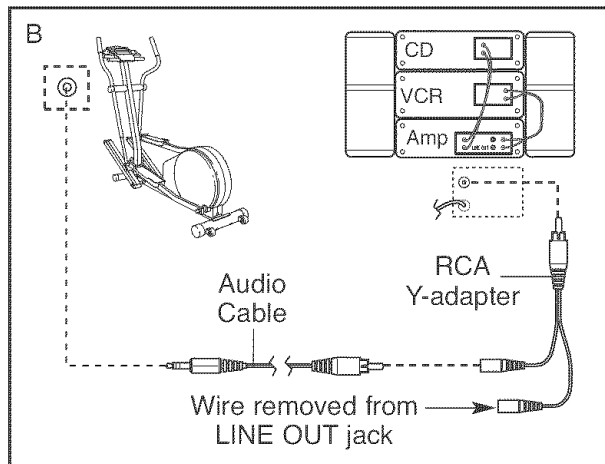

## HOW TO CONNECT YOUR COMPUTER

**Note:** If your computer has a 1/8" LINE OUT jack, see instruction A. If your computer has only a PHONES jack, see instruction B.

- A. Plug one end of a 1/8" to 1/8" stereo audio cable (available at electronics stores) into the jack beneath the console. Plug the other end of the cable into the LINE OUT jack on your computer.

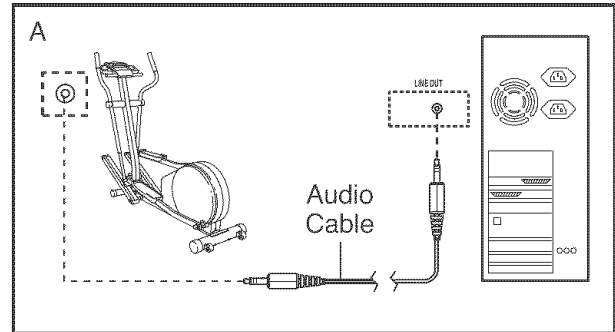

- B. Plug one end of a 1/8" to 1/8" stereo audio cable (available at electronics stores) into the jack beneath the console. Plug the other end of the cable into a 1/8" Y-adapter (available at electronics stores). Plug the Y-adapter into the PHONES jack on your computer. Plug your headphones or speakers into the other side of the Y-adapter.

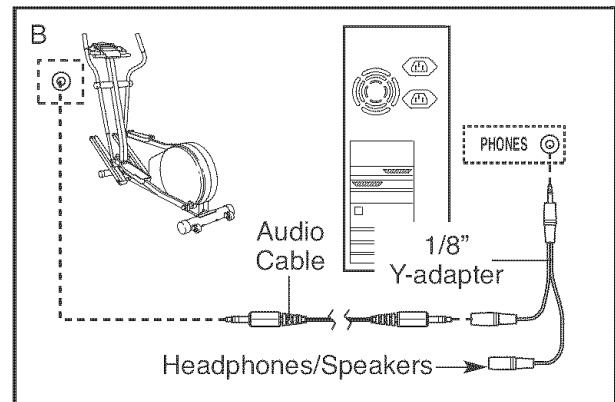

## HOW TO CONNECT YOUR VCR

**Note:** If your VCR has an unused AUDIO OUT jack, see instruction A below. If the AUDIO OUT jack is being used, see instruction B. If you have a TV with a built-in VCR, see instruction B. If your VCR is connected to your home stereo, see **HOW TO CONNECT YOUR HOME STEREO** on page 20.

- A. Plug one end of a 1/8" to RCA stereo audio cable (available at electronics stores) into the jack beneath the console. Plug the other end of the cable into the AUDIO OUT jack on your VCR.

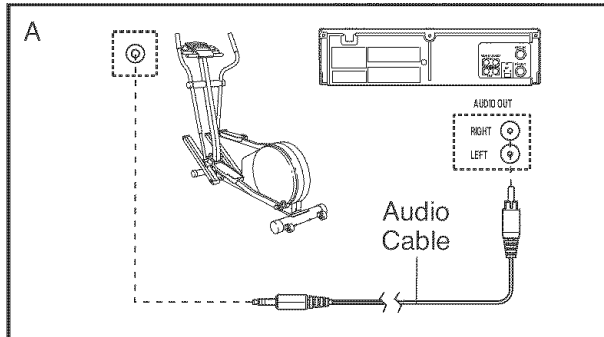

- B. Plug one end of a 1/8" to RCA stereo audio cable (available at electronics stores) into the jack beneath the console. Plug the other end of the cable into an RCA Y-adapter (available at electronics stores). Next, remove the wire that is currently plugged into the AUDIO OUT jack on your VCR and plug the wire into the unused side of the Y-adapter. Plug the Y-adapter into the AUDIO OUT jack on your VCR.

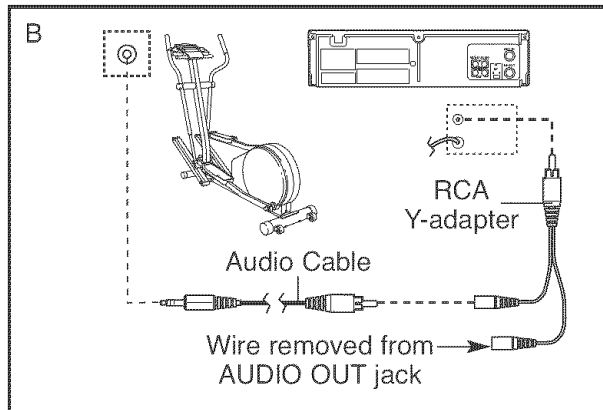

## HOW TO USE AN iFIT.COM CD OR VIDEO PROGRAM

To use an iFIT.com CD or video program, the elliptical exerciser must be connected to your CD player or VCR. See **HOW TO CONNECT YOUR CD PLAYER, VCR, OR COMPUTER** on pages 19 to 21. **To purchase iFIT.com CDs or videocassettes, call the toll-free telephone number on the front cover of this manual.**

Follow the steps below to use an iFIT.com CD or video program.

- 1 Press the Resistance decrease button or begin pedaling to turn on the console.**

A moment after the console is turned on, the display will light.

- 2 Select the iFIT.com mode.**

To select the iFIT.com mode, press the Programs button repeatedly until the track and the letters "iFIT" appear in the display.

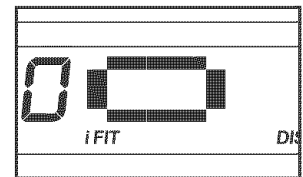

- 3 Press the Play button on your CD player or VCR.**

**Note:** If you are using an iFIT.com CD, insert the CD into your CD player; if you are using an iFIT.com videocassette, insert the videocassette into your VCR.

A moment after the play button is pressed, your personal trainer will begin guiding you through your workout. Simply follow your personal trainer's instructions.

The program will function in almost the same way as a resistance & rpm program (see step 3 on page 17). However, an electronic "chirping" sound will alert you when the resistance setting and/or pace setting is about to change.

**Note:** If the resistance of the pedals and/or the pace setting does not change when a “chirp” is heard:

- Make sure that the letters “iFIT” appear in the display.
- Adjust the volume of your CD player or VCR. If the volume is too high or too low, the console may not detect the program signals.
- Make sure that the audio cable is properly connected and that it is fully plugged in.

**4** Monitor your progress with the display.

See step 4 on page 13.

**5** Measure your heart rate as desired.

See step 5 on page 14.

**6** Turn on the fan if desired.

See step 6 on page 14.

**7** When you are finished exercising, the console will automatically turn off.

See step 7 on page 14.

**HOW TO USE AN iFIT.COM PROGRAM DIRECTLY FROM OUR WEB SITE**

Our Web site at [www.iFIT.com](http://www.iFIT.com) allows you to play iFIT.com programs directly from the internet. To use programs from our Web site, the elliptical exerciser must be connected to your home computer. See HOW TO CONNECT YOUR COMPUTER on page 20. In addition, you must have an internet connection and an internet service provider. A list of specific system requirements is found on our Web site.

Follow the steps below to use a program from our Web site.

**1** Press the Resistance decrease button or begin pedaling to turn on the console.

A moment after the console is turned on, the display will light.

**2** Select the iFIT.com mode.

See step 2 on page 21.

**3** Go to your computer and start an internet connection.

**4** Start your Web browser, if necessary, and go to our Web site at [www.iFIT.com](http://www.iFIT.com).

**5** Follow the desired links on our Web site to select a program.

Read and follow the on-line instructions for using a program.

**6** Follow the on-line instructions to start the program.

When you start the program, an on-screen countdown will begin.

**7** Return to the elliptical exerciser and begin pedaling.

When the on-screen countdown ends, the program will begin. The program will function in almost the same way as a resistance & rpm program (see step 3 on page 17). However, an electronic “chirping” sound will alert you when the resistance setting and/or pace setting is about to change.

**8** Monitor your progress with the display.

See step 4 on page 13.

**9** Measure your heart rate if desired.

See step 5 on page 14.

**10** Turn on the fan if desired.

See step 6 on page 14.

**11** When you are finished exercising, the console will automatically turn off.

See step 7 on page 14.

# MAINTENANCE AND TROUBLESHOOTING

Inspect and tighten all parts of the elliptical exerciser regularly. Replace any worn parts immediately.

To clean the elliptical exerciser, use a damp cloth and a small amount of mild soap. **Important: To avoid damage to the console, keep liquids away from the console and keep the console out of direct sunlight.**

## BATTERY REPLACEMENT

If the console displays become dim, the batteries should be replaced; most console problems are the result of low batteries. See assembly step 7 on page 7 for replacement instructions.

## HOW TO LEVEL THE ELLIPTICAL EXERCISER

If the elliptical exerciser rocks slightly on your floor during use, turn one or both of the leveling feet beneath the rear stabilizer until the rocking motion is eliminated.

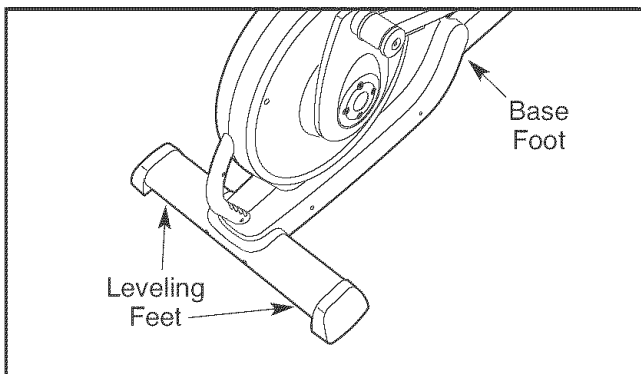

## HANDGRIP PULSE SENSOR TROUBLESHOOTING

- Avoid moving your hands while using the handgrip pulse sensor. Excessive movement may interfere with heart rate readings.
- Do not hold the metal contacts too tightly; doing so may interfere with heart rate readings.
- For the most accurate heart rate reading, hold the metal contacts for about 30 seconds.
- For optimal performance of the handgrip pulse sensor, keep the metal contacts clean. The contacts can be cleaned with a soft cloth—**never use alcohol, abrasives, or chemicals.**

## HOW TO ELIMINATE FLEXING IN THE CENTER OF THE ELLIPTICAL EXERCISER

If the elliptical exerciser flexes in the center during use, turn the base foot (see the drawing at the left) until the flexing is eliminated.

# CONDITIONING GUIDELINES

## WARNING:



Before beginning this or any exercise program, consult your physician. This is especially important for persons over the age of 35 or persons with pre-existing health problems.

The pulse sensor is not a medical device. Various factors may affect the accuracy of heart rate readings. The pulse sensor is intended only as an exercise aid in determining heart rate trends in general.

The following guidelines will help you to plan your exercise program. Remember that proper nutrition and adequate rest are essential for successful results.

### EXERCISE INTENSITY

Whether your goal is to burn fat or to strengthen your cardiovascular system, the key to achieving the desired results is to exercise with the proper intensity. The proper intensity level can be found by using your heart rate as a guide. The chart below shows recommended heart rates for fat burning, maximum fat burning, and cardiovascular (aerobic) exercise.

165	155	145	140	130	125	115	
145	138	130	125	118	110	103	
125	120	115	110	105	95	90	
<hr/>							
20	30	40	50	60	70	80	

To find the proper heart rate for you, first find your age at the bottom of the chart (ages are rounded off to the nearest ten years). Next, find the three numbers above your age. The three numbers are your “training zone.” The lower two numbers are recommended heart rates for fat burning; the highest number is the recommended heart rate for aerobic exercise.

### Fat Burning

To burn fat effectively, you must exercise at a relatively low intensity level for a sustained period of time.

During the first few minutes of exercise, your body uses easily accessible *carbohydrate* calories for energy. Only after the first few minutes of exercise does your body begin to use stored *fat* calories for energy. If your goal is to burn fat, adjust the intensity of your exercise until your heart rate is near the lowest number in your training zone as you exercise.

For maximum fat burning, adjust the intensity of your exercise until your heart rate is near the middle number in your training zone as you exercise.

### Aerobic Exercise

If your goal is to strengthen your cardiovascular system, your exercise must be “aerobic.” Aerobic exercise is activity that requires large amounts of oxygen for prolonged periods of time. This increases the demand on the heart to pump blood to the muscles, and on the lungs to oxygenate the blood. For aerobic exercise, adjust the intensity of your exercise until your heart rate is near the highest number in your training zone as you exercise.

### WORKOUT GUIDELINES

Each workout should include the following three parts:

**A warm-up**, consisting of 5 to 10 minutes of stretching and light exercise. A proper warm-up increases your body temperature, heart rate, and circulation in preparation for exercise.

**Training zone exercise**, consisting of 20 to 30 minutes of exercising with your heart rate in your training zone. Note: During the first few weeks of your exercise program, do not keep your heart rate in your training zone for longer than 20 minutes.

**A cool-down**, with 5 to 10 minutes of stretching. This will increase the flexibility of your muscles and will help to prevent post-exercise problems.

### EXERCISE FREQUENCY

To maintain or improve your condition, complete three workouts each week, with at least one day of rest between workouts. After a few months of regular exercise, you may complete up to five workouts each week if desired. The key to success is to make exercise a regular and enjoyable part of your everyday life.

# PART LIST—Model No. 831.28544.1

R1105A

Key No.	Qty.	Description	Key No.	Qty.	Description	Key No.	Qty.	Description
1	1	Base	42	4	Crank Bushing	84	4	M8 x 23mm Button Screw
2	1	Frame	43	2	Crank Bushing Sleeve			
3	1	Upright	44	2	Crank Bearing Set	85	1	M6 x 10mm Button Screw
4	1	Console Bracket	45	1	Crank			
5	1	Console	46	1	Crank Spacer	86	2	Crank Screw
6	1	Front Stabilizer	47	2	Crank Snap Ring	87	8	Hub Screw
7	1	Rear Stabilizer	48	1	Upper Wire Harness	88	10	M8 Washer
8	1	Left Handlebar	49	1	Lower Wire Harness	89	2	M10 x 60mm Button Screw
9	1	Right Handlebar	50	1	Reed Switch/Wire			
10	2	Handlebar Endcap	51	1	Belt	90	3	M8 Split Washer
11	1	Left Upper Body Arm	52	1	Flywheel	91	1	Flywheel Spacer
12	1	Right Upper Body Arm	53	1	“C” Magnet	92	1	Flywheel Washer
13	1	Left Pedal	54	1	Pillow Block	93	1	Flywheel Snap Ring
14	1	Left Pedal Leg	55	1	Magnet	94	4	Pillow Block Screw
15	1	Right Pedal	56	1	Spring	95	1	Stop Screw
16	1	Right Pedal Leg	57	1	Idler	96	1	M8 x 35mm Screw
17	2	Upright Cover	58	1	Idler Bracket	97	1	“E” Clip
18	1	Left Front Handlebar Cover	59	1	Clamp	98	4	Pulley Screw
			60	1	Reed Switch Bracket	99	2	Crank Washer
19	1	Left Rear Handlebar Cover	61	1	Base Pin	100	2	M4 x 25mm Screw
			62	2	Latch Bracket Spacer	101	8	M4 x 16mm Round Head Screw
20	1	Right Front Handlebar Cover	63	2	Hair Pin			
			64	1	Latch Bracket	102	4	Motor Washer
21	1	Right Rear Handlebar Cover	65	1	Pivot Bracket	103	23	M4 x 16mm Screw
			66	2	Pivot Bracket Spacer	104	8	M4 x 14mm Screw
22	1	Water Bottle Holder	67	1	Frame Pin	105	6	M4 x 32mm Round Head Screw
23	2	Front Stabilizer Endcap	68	1	Latch Button			
24	2	Rear Stabilizer Endcap	69	1	Roll Pin	106	2	M8 x 31mm Shoulder Screw
25	2	Wheel	70	1	Motor			
26	1	Base Foot	71	1	Resistance Cable Pulley	107	4	M4 x 12mm Screw
27	2	Leveling Foot	72	1	Resistance Cable Set	108	2	M4 x 45mm Screw
28	1	Left Side Shield	73	2	Foam Grip	109	2	Large Wave Washer
29	1	Right Side Shield	74	1	Pivot Axle	110	2	M8 Small Washer
30	6	Upper Body Bushing	75	2	Hub Cover	111	2	Wave Washer
31	4	Pedal Leg Cover	76	2	Outer Crank Cover	112	8	Star Washer
32	2	Pedal Leg Axle	77	4	M6 x 20mm Button Screw	113	1	M10 Washer
33	4	Pedal Leg Bushing				114	1	M6 Nut
34	1	Base Axle	78	4	M8 x 43mm Button Bolt	115	4	M8 x 23mm Shoulder Screw
35	2	Base Bushing	79	7	M8 Jamnut			
36	2	Crank Arm	80	1	M8 x 69mm Button Bolt	116	2	Flywheel Bracket
37	2	Inner Crank Cover	81	4	M10 Nylon Locknut	#	3	Allen Wrench
38	2	Crank Hub	82	2	M10 x 80mm Carriage Bolt	#	1	Grease
39	1	Pulley Spacer				#	1	User’s Manual
40	1	Pulley	83	2	M10 x 127mm Button Screw			
41	2	Crank Bushing Cover						

Note: “#” indicates a non-illustrated part. Specifications are subject to change without notice. **If a part is missing, call toll-free 1-888-533-1333.** See the back cover of this manual for information about ordering replacement parts.

# EXPLODED DRAWING A—Model No. 831.28544.1

R1105A

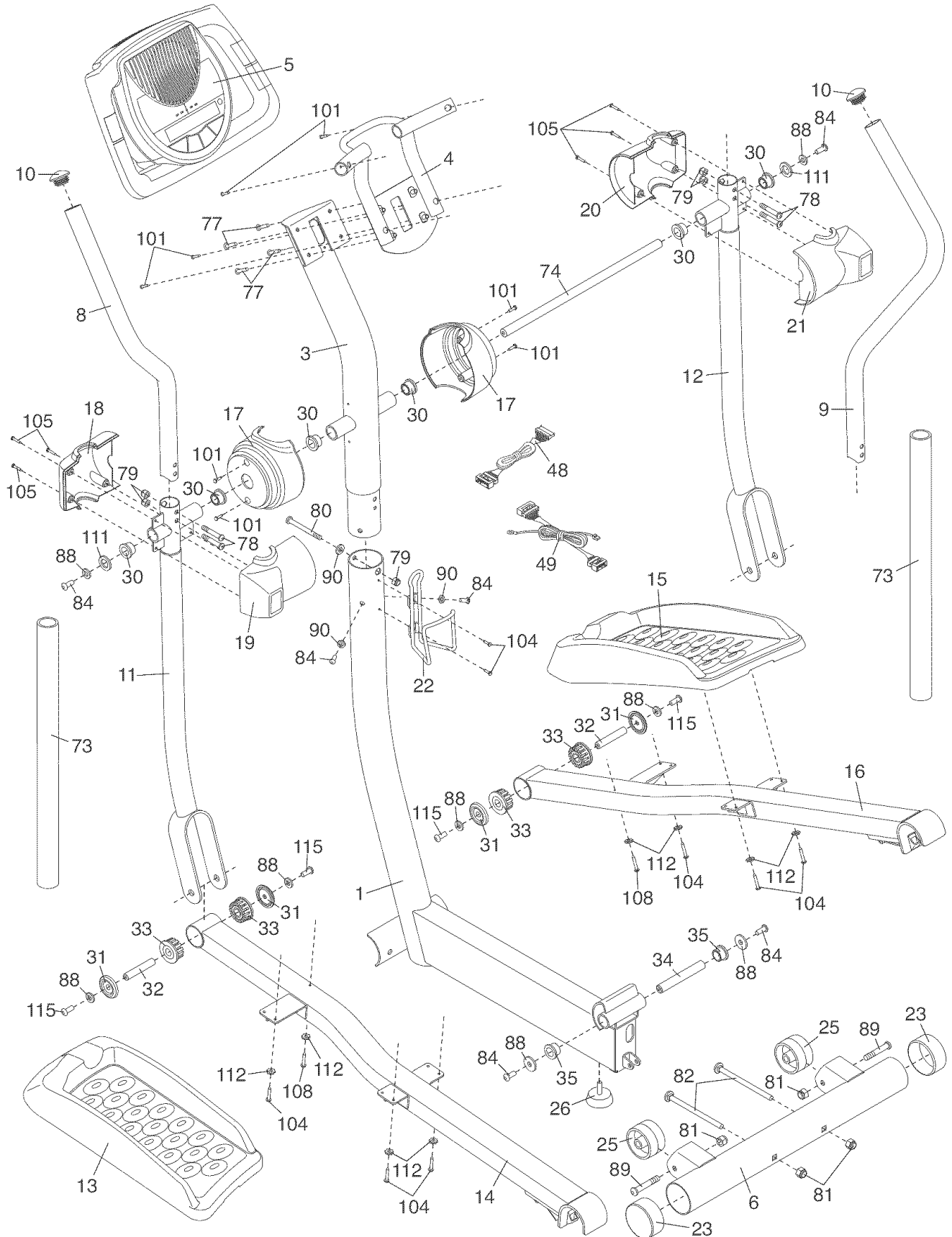

# EXPLODED DRAWING B—Model No. 831.28544.1

R1105A

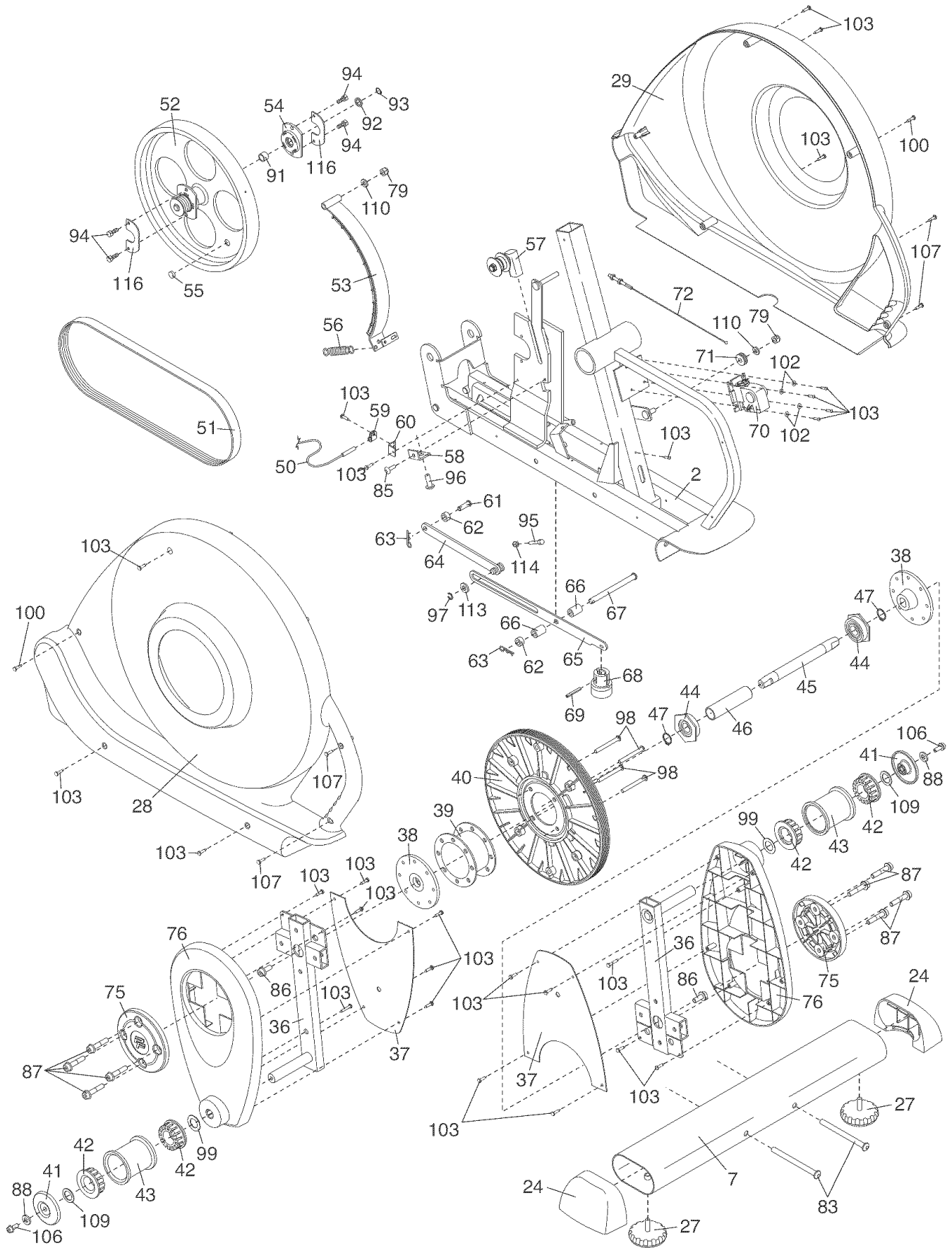

## Get it fixed, at your home or ours!

### Your Home

For repair – **in your home** – of **all** major brand appliances, lawn and garden equipment, or heating and cooling systems, **no matter who made it, no matter who sold it!**

For the replacement parts, accessories, and user's manuals that you need to do-it-yourself.

For Sears professional installation of home appliances and items like garage door openers and water heaters.

**1-800-4-MY-HOME®**

(1-800-469-4663)

[www.sears.com](http://www.sears.com)

Anytime, day or night

(U.S.A. and Canada)

[www.sears.ca](http://www.sears.ca)

### Our Home

For repair of carry-in products like vacuums, lawn equipment, and electronics, call or go on-line for the location of your nearest **Sears Parts and Repair Center.**

**1-800-488-1222** Anytime, day or night (U.S.A. only)

[www.sears.com](http://www.sears.com)

To purchase a protection agreement (U.S.A.) or maintenance agreement (Canada) on a product serviced by Sears:

**1-800-827-6655** (U.S.A.)

**1-800-361-6665** (Canada)

Para pedir servicio de reparación a domicilio, y para ordenar piezas:

**1-888-SU-HOGAR<sup>SM</sup>** (1-888-784-6427)

# SEARS

® Registered Trademark / ™ Trademark / ™ Service Mark of Sears, Roebuck and Co.  
© Marca Registrada / ™ Marca de Fábrica / ™ Marca de Servicio de Sears, Roebuck and Co.

## FULL 90 DAY WARRANTY

For 90 days from the date of purchase, if failure occurs due to defect in material or workmanship in this Sears Elliptical Exerciser, contact the nearest Sears Service Center throughout the United States and Sears will repair or replace the Elliptical Exerciser, free of charge.

This warranty does not apply when the Elliptical Exerciser is used commercially or for rental purposes.

This warranty gives you specific legal rights, and you may also have other rights which vary from state to state.

**Sears, Roebuck and Co., Dept. 817WA, Hoffman Estates, IL 60179**